

DRIVER

POWER TOOLS

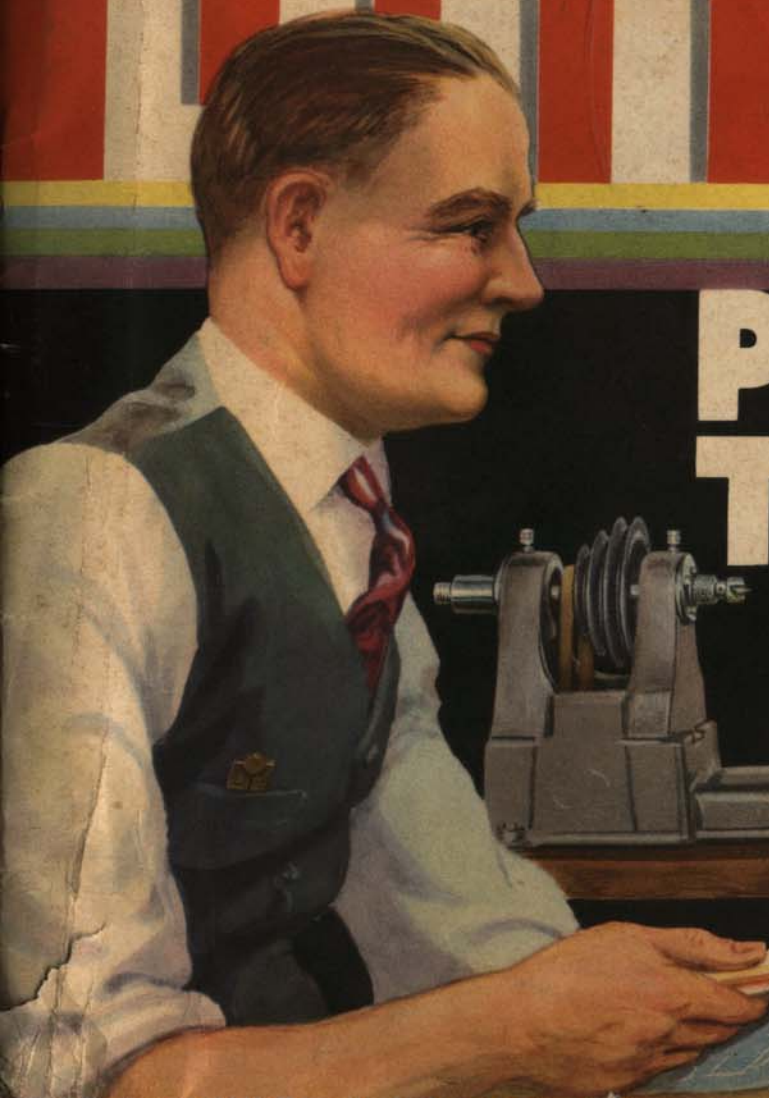

FOR THE AMATEUR AND PROFESSIONAL CRAFTSMAN

Three Lines of **POWER TOOLS** } **ONE STANDARD** of **QUALITY**

Accurate and rugged enough for the most exacting craftsman. Priced within the reach of all.

Startling new features . . . new ideas in design . . . time-saving conveniences . . . and still greater value characterize the new DRIVER power tool line. The splendid new models in the 500, 700, and 900 series challenge comparison. Their correctness of design will win approval from the most critical engineer . . . their refinements will appeal to the seasoned craftsman . . . their outstanding utility value and reasonable cost are certain to gratify the man who is starting his own workshop. Everyone interested in tools will be impressed by the sterling quality of the new models.

The acid test of performance . . . over a period of years . . . in the hands of thousands of owners . . . assures you utmost value per dollar spent, in DRIVER TOOLS.

WALKER-TURNER CO. INC.
Plainfield N. J., U. S. A.

The Walker-Turner Company reserves the right to make changes in design or to make additions to or improvements in its



products without imposing any obligation upon itself to install them on its product previously manufactured.



We reserve the right to change prices without notice when necessary to offset varying costs of manufacture.

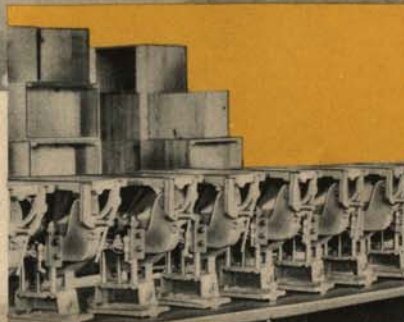

List prices are F. O. B. Plainfield, N. J. Subject to increases up to 5% at distant points, for transportation.

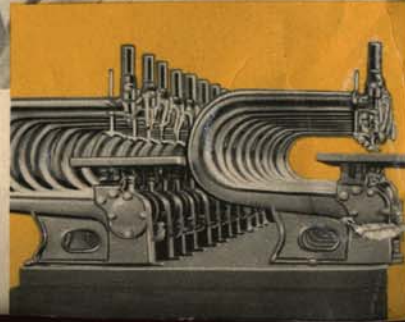

Introducing THE DRIVER "Series 500" LINE

One year ago the first "Series 500" tools were announced. That they were welcomed with real enthusiasm is proved by the remarkable sales records these tools quickly rolled up. During the year their sales constantly increased. In this period the "Series 500" tools definitely proved beyond the slightest possibility of a doubt that a power tool does not have to weigh two or three hundred pounds to be a quality tool. Outstanding quality can be built into lighter tools—by DRIVER.

The "500" tools were designed to fill a very definite need. Thousands of men who have started home workshops, or want to, do not feel that they can invest as much money in power tools as the heavier models require.

Neither do these men need all the capacity or conveniences incorporated in the larger tools. Every "500" tool will turn out first-class work . . . comparable with the best. That, after all, is the chief requirement of any tool.

The new "500 Series" is a better line than the previous one, just as every new DRIVER tool has been better than its predecessor. It is built to the same standard of mechanical exactness as the "700" and "900" Series. In not a single instance has an inferior material been substituted for a better one to

effect a saving in cost. Some of the new models are entirely new. Others refined and improved. In this line you will see features that you had considered only possible in very expensive machines.



DRIVER

L 500



Woodworking Lathe

Including 72 Page
Book of Instructions

\$12.95 as shown

Features

Sturdy cast iron bed, carefully ground.
Bed 34½" long, 2¾" high.
Distance between centers 24", swing 8".
Head and tail stocks take No. 1 Morse Taper centers.
Hollow head spindle, ¾" inside diameter.
Outside diameter head spindle ¾".
Bearings oilless bronze, ball thrust in head stock.
Tail stock has set-over for turning tapers.
6" Tool rest regular equipment.
18" steel tool rest available at slight extra cost.
Metal working attachments available.
Motor recommended ¼ or 1/3 H.P. 1750 R.P.M.
Normal operating speed 1750 R.P.M.
Shipping weight 36 lbs.

Accessories

33 Jacobs Chuck...\$5.25	L376 ½" Skew Chisel.\$1.10
5L5 Spur center.... .85	L377 ½" Spear Point 1.10
5L6 Cup center for Tail stock..... .85	5L10 6" Face Plate (¾" Hole) 1.10
5L8 Arbor for Jacobs Chuck85	5L11 3" Face Plate with Spurs and changeable center. 1.65
5L9 Arbor for Grinding wheels, etc.... 1.10	5L12 18" Tool Rest with Bed Brackets. 1.95
FS411 Sanding Drum 1.10	PV4 4" Four-step V Pulley55
L346 Skew Chisel.. .55	VB42 42" V Belt.... .75
L347 Gouge Chisel.. .55	5L22 14" Extension Bed 1.10
L362 Parting Tool.. .55	5L21 Steady Rest.. 3.25
L363 1" Gouge Chisel .55	
L375 1" Gouge Chisel 1.10	

One of the most popular lathes built . . . a really fine lathe . . . with features and refinements found only in very expensive tools. Every essential to good lathe operation is included. The careful attention given this tool through the various steps of design, manufacture and assembly is evident in the finely ground spindles, the Morse Tapers, the self-lubricating bearings and the machined gray-iron castings.

An ideal lathe for either shop or home use. Whether used by professional or amateur this substantial, efficient lathe will give years of accurate, trouble-free service. A tool of such character has not ordinarily been available to the man of moderate means.

Hollow Head Spindle

An unusual feature . . . one you would expect to find only in very expensive machines . . . is the hollow head spindle. This permits turning of dowels, arrows, and small diameter rods of all kinds. With the universal chuck, work may be turned and slid through the spindle saving the time ordinarily required for changing the work.

Turning Is a Fascinating Diversion

Woodturning is an extremely fascinating diversion whether done for pleasure or profit. To see a piece of rough wood take form under contact of the turning chisel and change rapidly into a series of well-proportioned curves, shoulders, and beads is a rare treat indeed. With a little practice anyone can turn out beautiful novelties and furniture.

New Universal Chuck

A high quality all-steel chuck, guaranteed accurate. It is self-centering and holds round or hexagonal work. Has two sets of jaws for outside and inside chucking. Back plate supplied.
No. 5L17 3" Universal Chuck with extra jaws and back plate.\$12.75

New Low Price on Independent Jaw Chuck

Excellent quality, all-steel construction. Has four reversible jaws with individual screw adjustments for holding irregular work.
No. 5L15 3" Independent Jaw Chuck with back plate.....\$6.95

Extension Bed

By means of the extension bed (No. 5L22) the distance between centers can be lengthened to handle turnings of practically any length. The distance is varied by moving the extension bed nearer to, or further away from the main bed.

Steady Rest

When long stock is being turned it is advisable to use the steady rest. This is attached to the bed near the center of the stock. It should not bear heavily on the stock but prevent it from "whipping" when in motion.

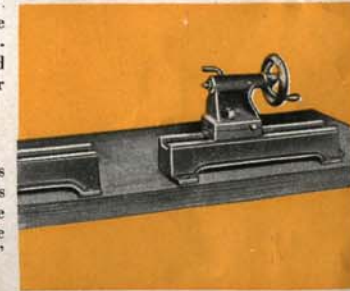

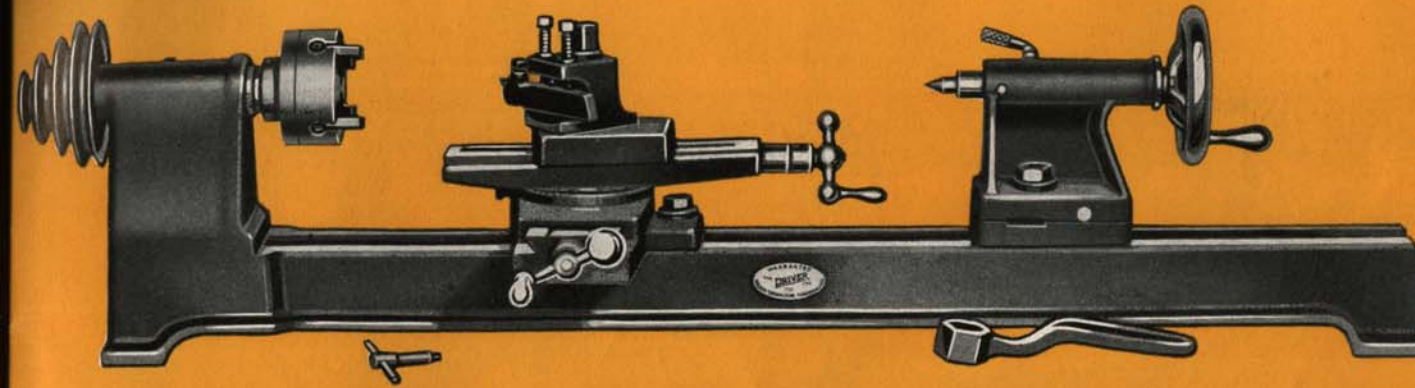

DRIVER L501

Metal Working Lathe

Including 72 Page
Book of Instructions

\$35.²⁵ as shown

Realizing that many craftsmen have been denied the use of a metal working lathe because of high prices, we have used every resource to provide a machine that would do many metal working jobs . . . at a very modest investment.

While the bed, head and tail stocks are identical with the Series 500 Woodworking Lathe, this is by no means a make-shift metal working job. In designing the lathe proper for woodworking, every essential of a metal lathe was considered and included. It has ample rigidity, strength and accuracy for fine metal work.

This sturdy compact lathe has untold possibilities for the home craftsman or mechanic. With it he can turn all the metals ordinarily worked in a lathe, do light spinning of brass, copper and pewter, make coil springs and wind coils. Replacement parts often can be made for a broken appliance or machine used about the home.

Electric repair shops and automobile service stations use this lathe for turning down commutators and winding coils. Industrial plants find it ideal for numberless small jobs. The home craftsman can make all kinds of attractive metal novelties and knick-knacks with the "500" metal working lathe. Metal working requires much slower lathe speeds than woodturning. For that reason it is essential that a jack-shaft or countershaft be installed between the motor and lathe head stock. Such an installation is shown at the right. The motor is suspended on the floating base (FL) its weight maintaining proper belt tension. A belt is run from a small groove of the motor pulley to a larger groove of the corresponding countershaft pulley thus reducing the countershaft speed below motor speed. A similar hook-up between countershaft and head stock pulley provides an additional speed reduction. By shifting the belts around, woodturning speeds are obtained.



No. L502 (Shown above) \$62.15

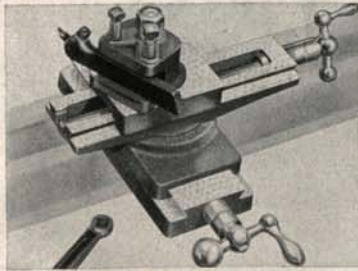

Compound Slide Rest

The compound slide rest illustrated above is used for turning metal. It clamps directly to the lathe bed. All bearing surfaces are precision-fitted assuring smooth, positive, and accurate action in all positions. It may be set at any angle on the horizontal plane, moved toward and away from the head stock (longitudinally) and crosswise of the bed (transversely). Distance of longitudinal feed 5/8", transverse 7".

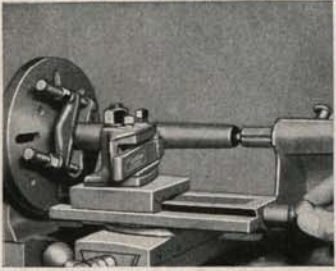

Turning Tapers

The photo shows a taper being turned on a steel bar. Provision was made in the design of DRIVER lathes to handle this type of work efficiently. The tail stock has a set-over whereby it may be moved crosswise of the bed in either direction thus throwing the tail stock out of center with the head stock. Movement is made by means of the two cap screws in the tail stock casting. By determining the amount of set-over needed, the actual turning of an accurate taper is a simple matter.

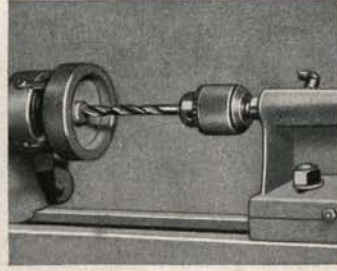

Boring

Here a small cast-iron flywheel is being drilled at the center. The casting is held by the jaws of the independent jaw chuck, the jaws having been expanded to grip the inner edge of flywheel rim. The Jacob's Key Chuck, attached to the 5L8 Arbor, is inserted in the tail stock. With this set-up the drill remains stationary, the work revolving. In the making of model engines and similar projects the "500" metal working lathe will quickly pay its way.

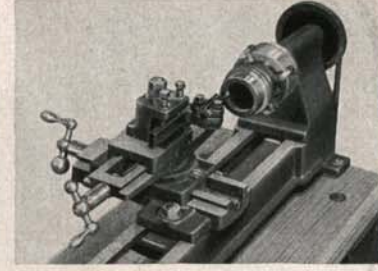

Turning a Bushing

In this photo a cut is being taken on the inside wall of a brass bushing. In order to get depth of cut a boring bar is used. This is just another example of the wide variety of work which the DRIVER metal working lathe is capable of doing. Iron, steel, copper and other metals can be worked just as effectively.

Reversing Switch

In metal turning it is often necessary to reverse the direction of the lathe. This may be done very readily if a motor reversing switch (RX10) is installed.

Consists of

L501	Lathe (shown at top of page)	\$35.25
5LB10	Bench Complete	15.50
OB25	Bronze Bushed Self Aligning Hangers (2 used) each \$2.95	5.90
OB26	Shaft 3/4" turned to 1/2" at ends85
VB42	Endless V Belt 42"75
VB34	Endless V Belt 34"60
FL1	Floating Motor Base	1.65
PV4	Pulleys (3 used) each .55	1.65

Accessories

5L15—3" Independent Jaw Chuck with Back Plate . . . \$6.95	Chuck with extra jaws and back plate . . . \$12.75
5L7—60 degree center for tail stock (with No. 1 Morse Taper) . . . \$8.50	5L23—Tool Holder with Bit and Wrench . . . \$1.60
5L16—Compound Tool rest with Tool Post not including 5L23 . . . \$12.95	33—Jacob's Chuck (Light pattern) . . . \$5.25
5L21—Steady Rest . . . \$3.25	5L18—3/4" Lathe Dog . . . \$5.55
5L17—3" Universal Chuck	5L25—Bit (Not Shaped) \$10
	5L8—Arbor for Jacob's Chuck \$8.85

(Accessories shown on opposite page are interchangeable with above. We recommend the use of a 1/3 H.P. 1750 R.P.M. Motor.)

DRIVER

J505



Features
 Table close-grained gray iron carefully ground 9" x 9".
 Throat capacity 14" (board 28" wide may be sawed).
 Rigid cast iron frame, strong tubular construction.
 Blade vises can be moved one-quarter turn so sawing may be done from sides as well as front. Very helpful on long pieces.
 Distance from upper vise to table 1½".
 Height overall 19½".
 Length overall 21".
 Splash system of oiling, requiring practically no attention.
 May be driven from countershaft or motor, a 2½" pulley is required.
 Table tilts to 45°, has accurate quadrant and indicator.
 Bronze bearings.
 Motor required, ¼ to ⅓ HP. 1750 RPM.
 Positive plunger type blower in head directs stream of air at point of cutting.
 Shipping weight 34 lbs.

14" Jig Saw

Including 72 Page
 Book of Instructions

\$11.50 as shown
 (less blade)

When starting to develop a workshop most craftsmen begin with the jig saw. The reason for this undoubtedly is because the jig saw is a complete creative machine in itself. A wide variety of projects can be made entirely on the jig saw—without the help of other machines or tools.

Jig sawing puzzles, doll furniture, toys, wood or metal letters, silhouettes and hundreds of other similar projects is certainly a pleasant pastime. In the past few years many jig saws have assisted materially in balancing the family budget.

What's fun with an ordinary jig saw is a real thrill with the new DRIVER "Series 500." It operates quieter, cuts better, is easier to handle and requires no "time out" for repairs or adjustments. The tubular type cast iron frame keeps vibration down to a minimum. The smooth-acting precision drive mechanism is finely balanced and good for years of trouble-free work.

An inspection of this machine will reveal its quality characteristics. It has no flimsy stampings to bend or become distorted. Its driving mechanism is entirely enclosed, protected from dust or dirt, operating continuously in an oil bath. Tests covering hundreds of hours of non-stop operation fail to develop any appreciable wear. Subjecting this machine to the same vibration tests as used on the highest priced jig saws prove that vibration in this machine has been reduced to the lowest possible minimum.

Accessories

5J2	Fine Blade Visers (pair).....	1.10	VB42	42" V Belt.....	.75
5J3	Hold Down and Guide for Puzzle Work.....	1.10	PV25	2½" V Pulley.....	.30
5J4	Large Blade Visers (pair).....	1.10	EL5	Driver Flexo Lamp.....	1.50

All blades listed on Page 17

Designs on Wood

Designs of a platoon of soldiers, a zoo of animals, a whole 16-piece set of doll furniture, and a double alphabet set—all on panels of wood with the actual lines for cutting out printed right on the wood itself. Here is a service that will interest

every jig saw owner—especially those who have difficulty in drawing their own designs.

Four sets, each comprising six imprinted panels available as follows:

No. DAEF103	A.E.F. Soldiers (authentic equipment)	25 pieces	\$.35
No. DAM104	Animal Set (32 pieces)		.35
No. DA102	Two complete alphabets		.35
No. DF100	Doll Furniture Set (16 pieces)		.35
No. DL105	Utility Lumber (6 plain panels) not imprinted		.35



Photo above shows intimate view of under-table construction and blade vises. The sturdy construction of the heavy cast iron base and arm is readily apparent. Note that driving mechanism is entirely enclosed in oil-tight crank case. No dust or dirt can get in to injure bearings. Every part of the cross-head driving mechanism is precision-fitted to assure quiet, smooth operation over a long period of time. The only lubrication necessary is to keep the crankcase filled with medium weight automobile oil up to the level of the filling plug. This mechanism, after being run for 43 days and nights continuously showed no evidence of wear. In this period of time it made 39,312,000 revolutions.



DRIVER B 575

7" Bench Saw

Including 72 Page Book
of Instructions

\$10.50 as shown
(less idler)

The quality of this bench saw cannot be fairly judged by its price. It will be difficult, if not impossible, to find a bench saw anywhere, in this price range with quality comparable to that embodied in this machine.

A glance at the specifications will show you what a remarkable saw this is. A seven-inch blade with cutting capacity of $2\frac{1}{4}$ ". A ground cast iron table 14" x 10". A saw arbor that raises and lowers. Oil-less bronze bearings. A high grade safety guard with the latest approved type splitter. A table that tilts to 45° with adjustable stops at the 90° and 45° positions. And a heavy, machined steel ripping fence. Here are specifications that many bench saws selling at higher prices could not meet.

The DRIVER "500" Bench Saw does first-class work. Angle sawing, mitering and dadoing are done as accurately as straight work. The blades themselves are of high quality steel and will prove satisfactory in every respect.

Two Types of Drive

The idler pulley illustrated detached from the machine should be used when the belt is run from a motor or countershaft that is fixed stationary, otherwise movement of the saw arbor up and down will vary the belt tension. If the source of power is fixed the idler pulley should be attached to the slot in the base directly above the idler as it is shown above. Then the 20" belt is run from the idler pulley to the saw arbor pulley, and a belt of proper length completes the drive from the idler pulley to the source of power.

If the saw is to be driven by an individual motor and this motor is mounted on the 9P5 floating motor base, the idler will not be necessary. A single belt from the saw arbor pulley to motor will be very satisfactory.



(B11 Mitre Gauge included)



With the saw stock $2\frac{1}{4}$ " usual capacity blade in its top position, thick can be sawed. Un- for a saw in this class.



View from above showing how splitter spreads saw cut slightly. This greatly facilitates sawing.

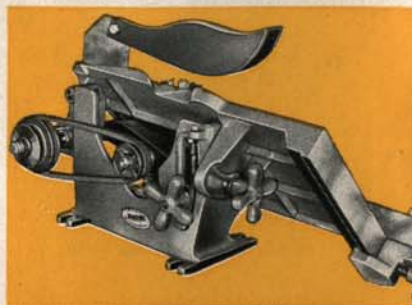

Showing the under-table mechanism, idler drive, table quadrant, and arbor raising and lowering device.

Accessories

D55	5 1/2" Dado outside saw (2 used), ea.....	\$1.10
D55A	5 1/2" Dado inside chipper.....	.40
B9	7" Cross Cut Saw.....	1.00
B9R	7" Rip Saw.....	1.00
VB39	39" V Belt (Motor to saw arbor).....	.60
VB20	20" V Belt (Idler to saw arbor).....	.50
VB29	29" V Belt (Motor to idler).....	.60
PV450	4" Motor Pulley (Direct Drive).....	.40
PV350	3" Motor Pulley (Idler Drive).....	.40
5B6	Idler Unit.....	1.00
B11	Miter Gauge.....	1.00

Features

Table 14" x 10", machined gray iron tilts to 45° . Has stop screws at 90° and 45° positions. Top is flat, not ribbed. Bearings oilless bronze. Saw arbor raises and lowers. Maximum depth of cut $2\frac{1}{4}$ ". Uses 7" diameter blades ($\frac{1}{2}$ " hole). Removable throat for dadoing. Idler pulley available at slight extra cost. Saw spindle $\frac{1}{2}$ " diameter. Efficient safety guard regular equipment. Splitter spreads saw kerf slightly, facilitating the sawing of green or damp lumber. Heavy machined steel ripping guide. Shipping weight 35 lbs.

Motor Requirements

For all average work the $\frac{1}{2}$ H.P. 1750 R.P.M. motor will be satisfactory. The use of a $\frac{1}{4}$ H.P. motor is not recommended unless very thin stock is to be cut. Operating speed should be around 3500 R.P.M. for best results.

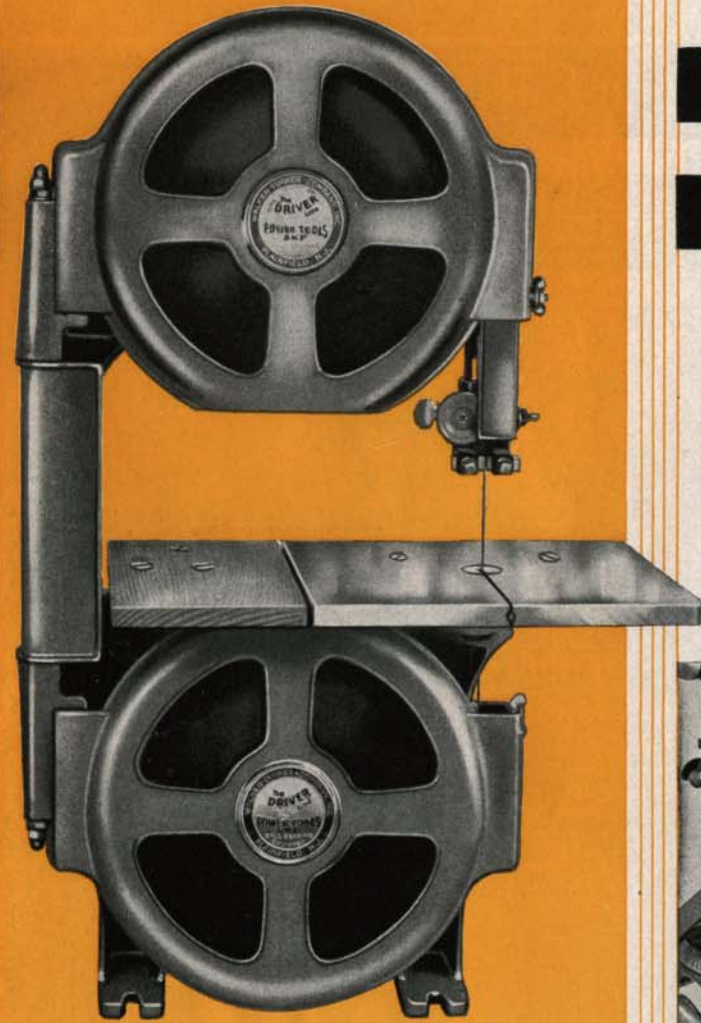

DRIVER

BN550

Accessories

5BN51	1/8" Band Saw Blade...	\$1.00
5BN52	3/16" Band Saw Blade..	1.00
5BN53	1/4" Band Saw Blade...	1.00
VB42	48" V Belt.....	.35
EL5	Driver Flexo Lamp*....	1.50
PV175	1 3/4" V Pulley.....	.30

*Illustrated on Page 38.

Thousands of craftsmen will welcome this new 10" Band Saw. For here is a quality tool! Extra attention to details is apparent in every feature. With a high quality band saw such as this available at so reasonable a cost, no workshop should be without one.

The SKF dust-sealed ball bearings, heavy cast iron frame, balanced disc wheels, ball bearing guide roller and table extension are features every craftsman will recognize as proof of finest quality.

With this band saw you can get the beautiful curves and graceful cuts so often needed in making attractive furniture. In the making of toys and novelties the band saw is also an asset.

Go to your local DRIVER dealer and ask to see the new "500" band saw. Note how smoothly it operates, how rigid and sturdy all parts are, how well protected by guards it is. Look at the new cushion type tensioner and the method of top wheel alignment. Then compare the "500" Driver band saw with others and you will again be impressed by the fact that DRIVER offers more in tool value per dollar spent.

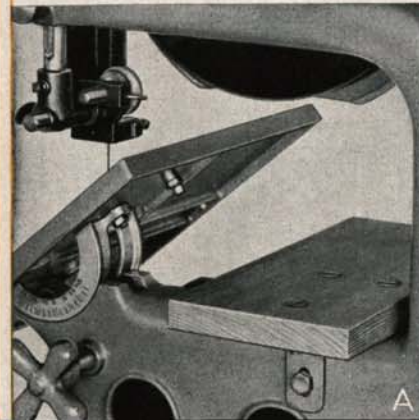

A

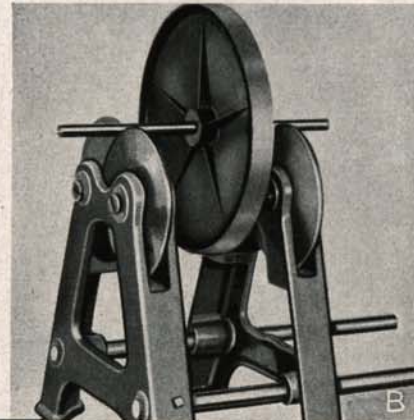

B

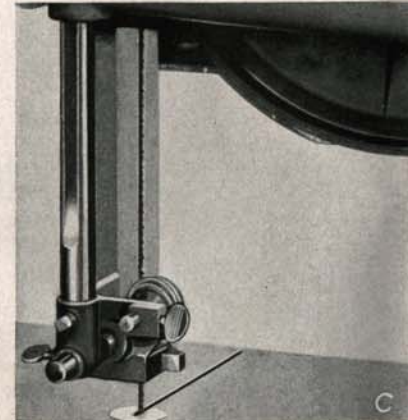

C

10" Ball Bearing Band Saw

Including 72 Page Book of Instructions

\$19.50
as shown

Features

- Rigid cast iron frame, heavily reinforced.
- Disc Wheels 10" diameter.
- Wheels balanced and rubber faced.
- 5 SKF ball bearings.
- Maximum distance guide to table 4".
- Distance blade to frame 10" Guards are both hinged and may be opened independently.
- Motor required 1/4 HP to 1/2 HP. 1750 RPM.
- Machined cast iron table, 10" x 10". (With wood extension 15" x 10".)
- Table tilts to 45°.
- Ball Bearing guide roller
- Height over all 26 1/2"
- Shipping weight 61 pounds

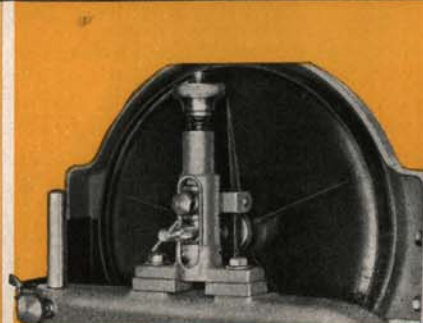

D

(A) Shows under view of table. The table tilts evenly and smoothly on frame. Graduated quadrant indicates degree of tilt. Table locked in position with hand wheel. Wood insert adjustable for height.

(B) One balancing test to which every DRIVER band saw wheel is subjected. Proper balancing of wheels is a very important point. Wheels out of balance invariably set up vibration which affects the quality of work done.

(C) A close up view showing construction of the upper guide assembly. The hardened steel disc which receives the saw thrust revolves on ball bearings. A soft metal disc in the table protects blade if forced out of line.

(D) Tension of the blade and alignment of the top wheel to make the blade track in the center are controlled by the precision-fitted, cushion type tensioner shown at the left. Adjustments may be made without any tools.

Features

- Length over all 23".
- Length of tables, each 9½".
- Width of front table at rabbeting arm 8".
- 3 high-speed steel knives.
- Bearings oilless bronze.
- Both tables adjustable.
- Tables cast iron, carefully ground.
- Guide 14¼" long, very rigid.
- Graduated quadrant on guide.
- Guard drops down for rabbeting.
- Balanced cutter head.
- Motor required, 1/4 to 1/3 H.P.
- Shipping weight 36 lbs.



4" Planer, or Jointer

Including 72 Page
Book of Instructions

\$12.95
as shown

New Type Guard Folds Out of Way When Rabbeting

When rabbeting with ordinary jointers it is necessary to remove the guard entirely from the machine. Not so with DRIVER Jointers. By means of a unique bracket the guard may instantly be dropped down out of the way, no tools being required. Another point of importance is that there is no extra charge for the guard—safety appliances being standard equipment on all DRIVER TOOLS.

Thousands of Driver Jointers in Use

From the first, DRIVER Jointers have been popular. Craftsmen everywhere, quick to see the unusual value built into these machines, added a DRIVER Jointer to their workshop. Not only are they used in thousands of home workshops, many are doing daily work in lumber mills, factories, cabinet and pattern shops. On many jobs they have replaced machines costing ten times as much—and are doing the job as well.

Accessories

VB34	34" V Belt	\$.60
PV450	4" V Pulley40
5P5	Extra Blades (set of three) ..	2.20

A good planer not only eliminates the drudgery of surfacing rough lumber . . . it also assures greater accuracy. With the machine properly set it is practically impossible to make the errors so common in hand planing. This means a definite saving, especially when expensive rare woods are being worked. The power planer can also pay for itself by salvaging old wood and by the savings effected in buying rough lumber instead of finished stock.

The new DRIVER "500" Planer was designed to provide the utmost in efficiency at a price well within the reach of all. It is not a cheap planer as close scrutiny will prove. A study of its specifications will convince you that a fair comparison can be made only with much more expensive machines.

Three High-Speed Knives

The advantage of having three high-speed knives instead of two carbon steel ones as ordinarily used is obvious. Much smoother work is obtained with less sharpening of the knives. Other advantages such as

adjustable tables, better design, greater weight, more convenient setting of the guide and superior safety guard are important factors which make this machine an outstanding value.

The balanced cutter-head is made integral with the shaft. The latest approved method of holding knives in their slots is used. Bearings are self-lubricating bronze. Base and tables are of close-grained gray iron strongly ribbed and carefully machined.

The guide is strongly reinforced for rigidity. The light metal guard affords full protection, receding as the work is fed. Thus the blades are kept covered at all times.

The smoothness, quietness and utter absence of vibration in this jointer even at top speed are sure indications of correct design, perfect balance and careful assembly. These factors contribute in a very real way to sustained accuracy of work and long life of the machine.

Be sure to see this new model in action at your local DRIVER store.

DRIVER

P525



Protractor on guide is accurately graduated to indicate angles of tilt. Easy to read and dependable.

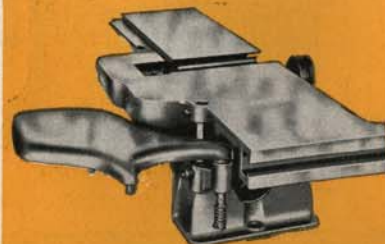

New type guard folds down out of way when rabbeting. No tools required to change position.

DRIVER

D520



Drill Selector

Eight highest quality carbon steel drills—in a unique container at a lower price than you ordinarily pay for drills alone.

Sizes 1/16", 3/32", 1/8", 5/32", 3/16", 1/4", 5/16", 3/8".
 TD117 Drill Selector (with 8 drills) . \$1.40
 9D5 Threaded adapter (used for shaping)85
 7D11 Collet chuck (used for routing, etc.)85

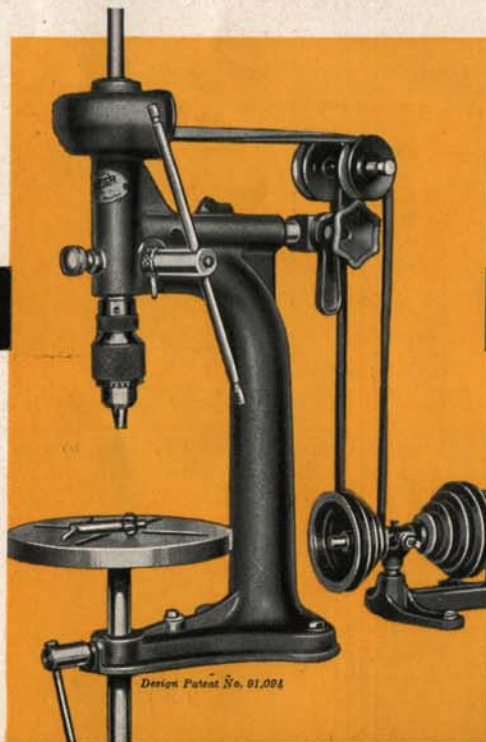

Design Patent No. 81,094

D521

With idler, DRIVER chuck, Belt and Pulley but without jack-shaft. (Not illustrated)

\$10.95



D522

Same as D521 but with Jacobs Chuck \$14.95

Drill Press

Including 72 Page Book of Instructions

\$14.95 as shown (less motor)



There's a challenge in every line of this superb drill press. The graceful flowing lines of the integrally cast head, stand and base are the rigid foundation of this perfect drilling machine. Add to this the machined steel quill, Jacob's Key Chuck, oilless bronze bearings, ball thrust bearing, carefully ground table and numerous other features and you will see how the Series 500 Drill Press profits by comparison. A drill press of these specifications in this price class has never before been available.

This drill press needs no favoring. It can be used for heavy drilling . . . on production work. Wood, metal, compositions . . . any kind of material you would drill on any standard machine . . . is handled quickly and efficiently with this remarkable drill press. Two types of drive are available, direct with motor mounted at rear of head, or with a jackshaft for hook-up with a pulley mounted on the bench. Eight speeds are provided by either hook-up.

Every possible convenience has been developed to simplify operation. A knurled screw in the front of the head locks the quill in any position. A slide-bar bolt secures the table at various heights. The countershaft drive model has a lever to vary the position of the idler pulleys to allow for variation in belt lengths. Thus, every necessary adjustment may be made easily and quickly, without the need of a wrench or any other tool.

Shaping and Routing

While this drill press is not intended to do routing or shaping on a steady production basis, yet it is perfectly satisfactory for an occasional job of either type. For shaping an improvised guide can be made by clamping a strip of wood to the table between the chuck and main column. Operating speed should be increased to about 4000-5000 R.P.M. for both operations. The 9D5 Threaded adapter is used for shaping, 7D11 Collet chuck for routing, etc.

Features

Capacity from 1/16" to 1/2" Drills.
 Rigid cast iron frame.
 Height overall 24".
 Distance table to chuck 7".
 Distance from frame to center of drill 5 1/2".
 Cast iron table (ground) dia. 8".
 Table adjustable up and down.
 8 speeds.
 Spindle travel 3 1/2".
 Diameter of spindle 5/8".

Oilless bronze bearings.
 Ball thrust bearing.
 Quill is made from solid steel bar with teeth milled into it.
 Quill lock and guide screw.
 Hand screw raises and lowers motor for pulley alignment.
 Motor base slides in and out, to regulate belt adjustment.
 Shipping weight (without motor) 32 lbs.

At left is a close-up view of the motor base support and adjusting mechanism. The hand wheel at the top raises or lowers the motor and base on a screw, aligning pulley grooves correctly when speeds are changed. Locked in position by hand wheel at left, wheel at right locks motor base support in lateral position.

The idler set-up has the same lateral movement for belt adjustment. A lever is provided to raise or lower the belt to align with either groove of the drill press pulley when speeds are changed.

Introducing THE DRIVER "Series 700" LINE

A home workshop . . . where he can work with tools to his heart's content . . . is an ideal for which thousands of men are striving. Every red-blooded man gets satisfaction from making articles of furniture, jig-sawing toy soldiers, or doll furniture for the kiddies, making inlaid gifts and knick-knacks, or effecting the necessary repairs about the home. Here is a hobby that satisfies and pays unusual dividends.

Having a home workshop for a hobby is healthful—it gives relaxation from the daily grind. It is fascinating—there's a thrill in watching a stick of wood transformed into a shapely turning under your chisel. It is educational—teaching you how to judge the quality of furniture you buy. Woodworking is also sport . . . not

competitive exactly . . . but sport nevertheless. It calls for your best, and there's plenty of exercise if you want it.

For the man with hobby interests the "700" line is ideal. It is composed of machines somewhat heavier than the "500" series and lighter than the "900" line. Many new improvements and features are found in the "700" line this year. A new gap-bed lathe with accessories for metal spinning, a new ball bearing band saw, a new bench saw and a new spindle shaper are among the latest models. Other models have been refined.

To get a fair conception of the remarkable features these tools embody, read the specifications, or, better yet, inspect the tools at your local DRIVER store. Your DRIVER dealer will gladly demonstrate them to you.



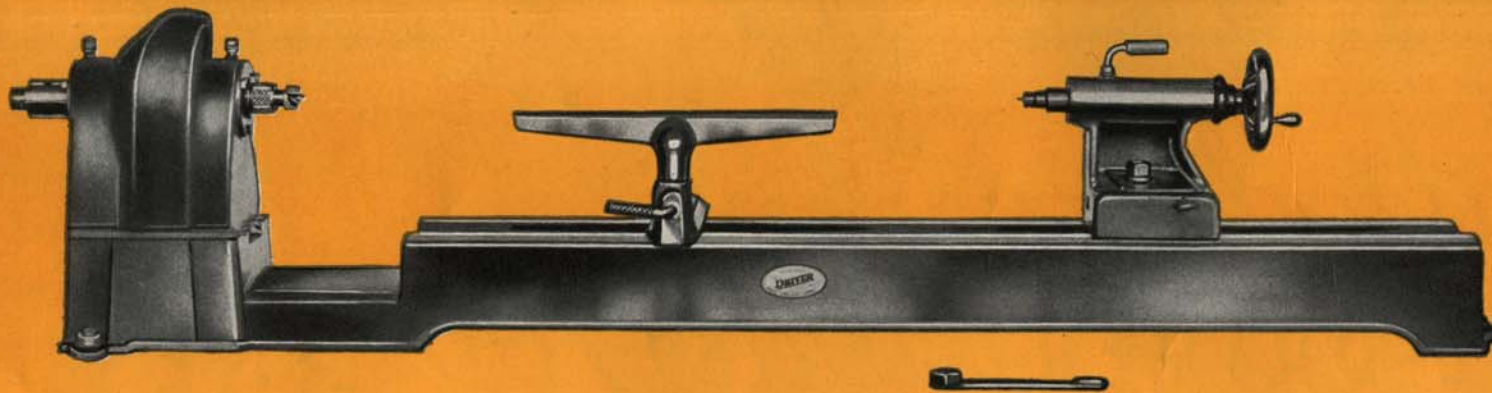

Including 72 page
Book of Instruction

\$29.95 as shown

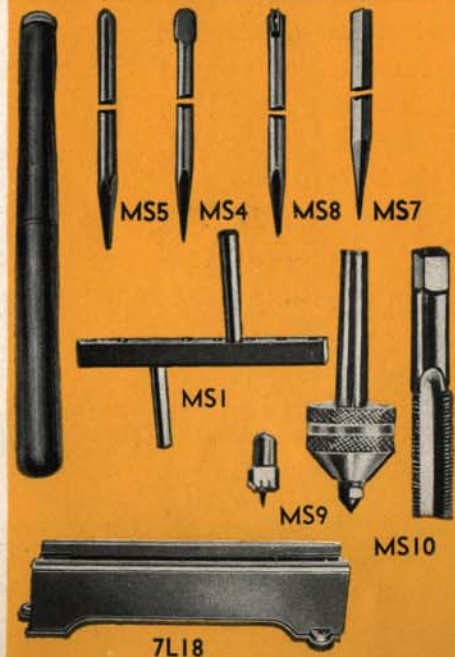
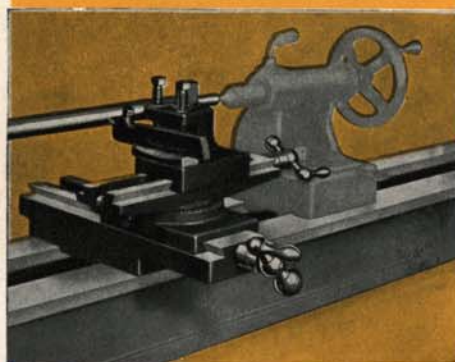

Features

Bed 54" long, 4 $\frac{3}{8}$ " high, gray iron.
Distance between centers 37".
Swing, at gap, 13 $\frac{1}{2}$ ".
Swing, rest of bed, 10".
Morse Taper centers (No. 2).
Hollow head spindle, $\frac{5}{8}$ " inside dia.
Dia. of spindle between bearings 1".
SKF Ball Bearings.
4 speeds. (700, 1300, 2300, 4200 R.P.M.)
Tail stock has set-over for tapers.
Extra strength and rigidity throughout.
Height over all 12".
(All accessories for "900" lathe may be used on the "700". Metal turning and spinning attachments available.)
Shipping weight 130 lbs.

Metal Spinning Accessories

MS-4	No. 1 Flat tool with handle....	\$2.00
MS-6	No. 2 Flat tool with handle....	2.00
MS-5	No. 1 Point tool with handle....	2.00
MS-1	Special tool rest for spinning....	1.75
MS-7	Cut-off tool with handle.....	2.00
MS-8	Beading tool with handle.....	2.50
MS-9	Ball bearing tail center complete	4.50
MS-10	1" Tap (for fitting forms to head stock)	2.50
940	Buffing compound.....	.30
FS426	6" cotton buffer.....	.50

Extension Bed

7L18 18" Extension bed (so designed that two or three sections may be arranged in a line, ends fit closely).\$5.50
(For woodworking and metal working accessories see Pages 22-23. All "900" Lathe accessories fit the "700".)

Here is a genuine all-purpose lathe. It embodies every worthwhile feature of a woodworking lathe . . . with the compound slide rest it is excellent for metal turning . . . and with its gap bed, it is an ideal lathe for metal spinning. The "700" lathe is really in a class by itself. It provides next year's refinements *this year!*

The gap bed feature was developed primarily for metal spinning, yet this extra capacity near the headstock will immediately appeal to the woodworker, because it enables him to turn unusually large face plate work without moving it to the opposite end of the head stock spindle.

SKF pre-loaded ball bearings (a double row at the right end of the spindle and a single row at the other) will easily carry any load that woodworking, metal-turning or metal spinning can impose. They provide full assurance that years from now the spindle will fit as closely as it does when it leaves the factory.

The bed is a heavy casting carefully machined. Rigidity, so essential to accurate lathe work, is an outstanding feature of DRIVER beds. The three-point lugs for attaching the lathe to the bench are a distinct advantage over those beds which are bolted down from four or six points along the sides of the bed. If the bench to which the lathe is bolted is uneven, bolting the bed tightly to it along the sides may distort it and pull the ways out of line. This cannot happen with the DRIVER three-point bed.

Considered from every possible angle, the DRIVER "700" lathe represents new and unusual tool value. Look it over,—and compare!

DRIVER L751 GAP BED LATHE

Metal Spinning Affords New Possibilities for the Craftsman

Spun articles of brass, pewter, copper or tin have always had intrinsic charm and value. The craft of metal spinning which is centuries old is used today in making beautiful vases, lamps, cups, pitchers, ash trays and receptacles of wide variety. Now, with the "700" lathe and metal spinning accessories you can spin these metals right in your own home—with designs to suit your fancy.

Spinning is not a difficult operation. In fact it is unbelievably simple. Basically all you do is turn a wood form the design of which will be identical with the inner form of the spun article. After the wood form is turned a disc of the metal to be spun is placed between the outer end of the wood form and the tail stock (with a small block of wood between the ball bearing tail center and the disc) and tightened up with the tail stock. The lathe is then started up and one of the spinning tools pressed against the edge of the disc. This pressure is shifted until the disc takes the exact shape of the form. There, briefly, is metal spinning.

Special Equipment Necessary

The first essential in spinning is a ball bearing tail center to replace the standard tail center. During spinning it is necessary to keep steady, uniform pressure on the work to prevent it from slipping and only a ball bearing tail center will fill this requirement.

Then a special tool rest, with a removable pin and a series of holes in the top section. The pin is moved from hole to hole during spinning to change the angle of leverage of the tool.

The spinning tools most commonly used are illustrated on the opposite page. They are heavy and rugged to prevent bending when leverage is applied.

A special 1" tap is also available for cutting threads in the wooden form so that it will screw directly on the head stock spindle. This arrangement is better than having the form attached to the face plate.

All Lathes Not Suitable for Metal Spinning

Because of the leverage exerted on head stock and bed unusual strength and rigidity are absolutely essential in these units. The DRIVER "700" and "900" lathes, with their massive head stocks and beds are ideally suited to this exacting work. Many other lathes, perhaps a majority, are entirely unqualified to meet the demands that metal spinning puts upon them.

Many spinning projects call for turned metal pieces to complete them. The compound slide rest and metal working chucks fit the "700" lathe and do excellent work on it.

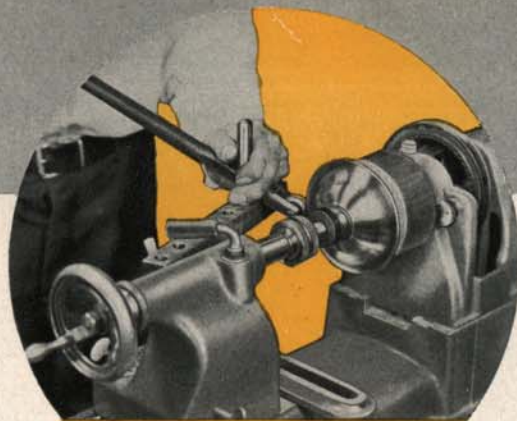

A

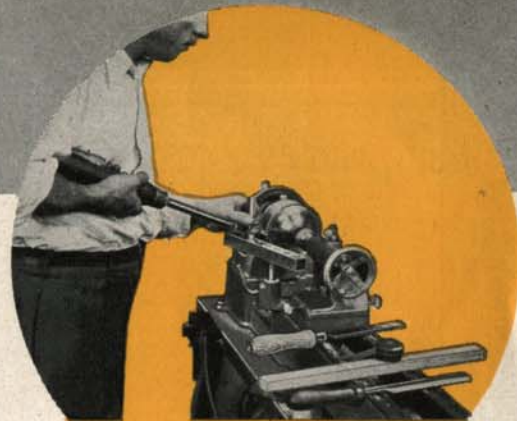

B

(A) This photo shows a bead being rolled on the edge of a shallow dish with the aid of the beading tool. This is done after the rest of the dish has been spun. While only one size of roller is supplied with beading tool MS8, others of larger or smaller diameters may readily be made to replace the standard one.

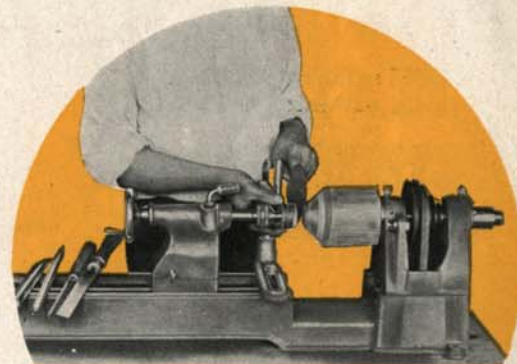

C

(B) Here the same beading tool used in A is being used to finish up the bead. Note the series of holes in the tool rest. The pin against which the operator's fingers rest is moved along the bar into different holes when the angle from which the pressure is exerted is changed.

(C) After the metal disc to be spun is cut out it is slipped into place between the right end of the form and the small block of wood which is backed against the ball-bearing tail center. It is centered as nearly as possible with the eye and then the tail stock center is run up against it and tightened.

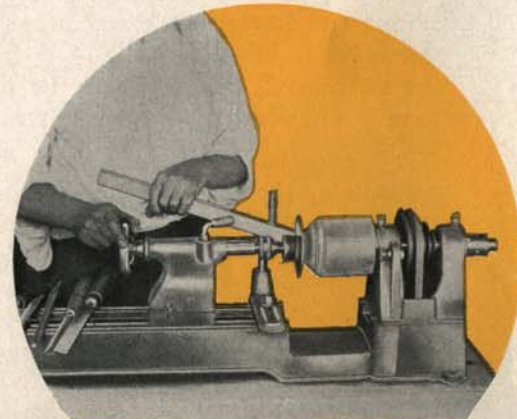

D

(D) Now the disc is centered accurately. This operation follows closely that described in C. With the disc slightly loose start the lathe up and hold a strip of wood against the edge of the disc until it runs in the center. It is advisable not to stand directly behind or in the front of the disc while centering as it might possibly come out. When the disc is accurately centered move the tail center in until it binds the disc rigidly in place.

DRIVER B735

8" BENCH SAW

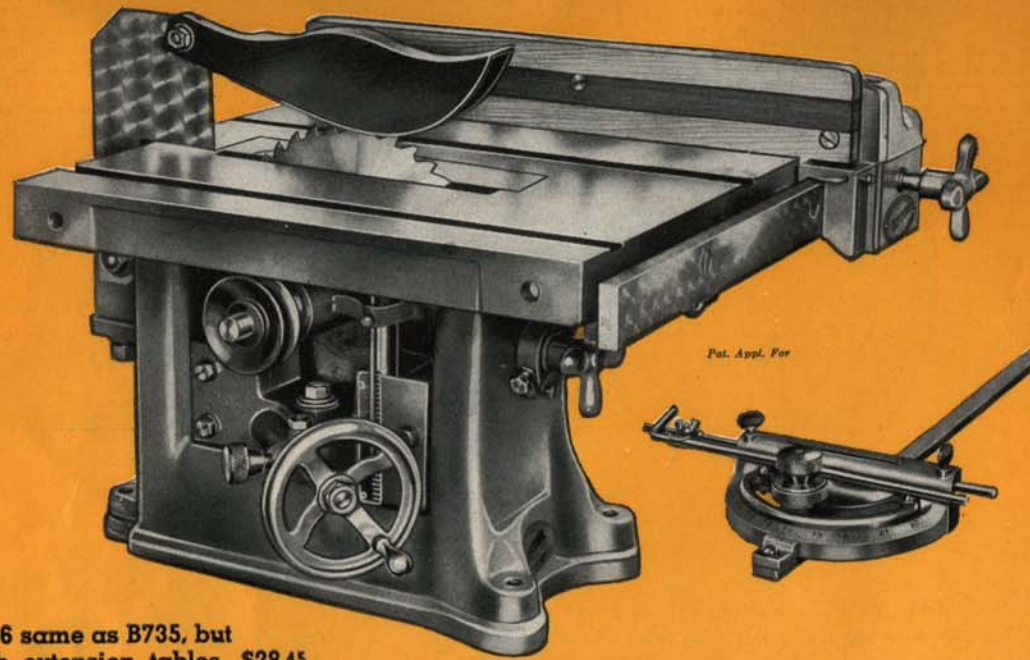

Pat. Appl. For

B736 same as B735, but with extension tables, \$28.45

Features

- Table size (normal) 16" x 13".
- Table size (with extensions) 16" x 25".
- Table is made of close-grained gray iron, top ground smooth and polished.
- Table tilts to 45°, a scale indicating the degree of tilt.
- Removable insert in table for dadoing.
- SKF ball bearings.
- Arbor raised or lowered by worm gear.
- Maximum depth of cut 2 1/4".
- Uses 8" diameter saw blades.
- Spindle 5/8" diameter.
- New geared self-indexing miter gauge.
- Ripping guide has laminated wood facing.
- Front extensions for table available at slight extra cost.
- Abrasive cut-off wheels available for cutting metal and ceramics.
- Splitter spreads wood slightly facilitating the sawing of green or damp wood.
- Sawdust chute in base.
- Motor recommended—for light work 1/3 H.P. 1750 R.P.M.
- Motor recommended—for heavy work 1/2 H.P. 3450 R.P.M.
- Shipping weight 85 lbs.

\$21.95 Including new self indexing miter gauge

Including 72 Page Book of Instruction

This new saw is a fine example of superior engineering. In its strength, simplicity and convenience of operation have been developed to an almost unbelievable degree. Every one of its unique features contribute in a definite way to greater accuracy, speed and safety.

A glance at the photos (at the right) will show you how effectively every detail has been taken care of. The new wood-faced ripping fence, the precision worm gear mechanism for raising and lowering the saw arbor and the adjustable stop screws for locating the table at 45° and 90°, are just a few of the refinements that indicate the thought and study which have been spent in designing this superior bench saw.

Table Extensions Available

Realizing the added advantages and convenience of a large table area especially when large stock is to be sawed, we have available two table extensions. Each extension is 6" wide and 16" long. Holes for bolting the extensions in place are located on right and left sides of the main table. Attaching requires only a few minutes. A pair of extension rails for the front of the table is also available. Strips of wood or rollers may be inserted between the rails to rest long pieces on when ripping.

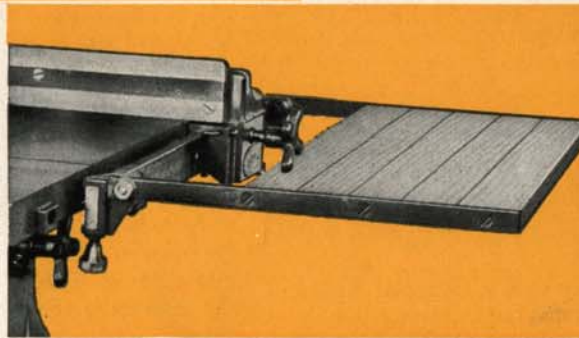

The extension rods shown above, attached to the front of the table and filled in with rollers or wood strips, are a great help when ripping long pieces.



D56 D56A

Worm Gear Mechanism

The worm gear raising and lowering mechanism (an exclusive DRIVER development) will immediately be recognized as an outstanding feature. Gears are entirely enclosed in a dust-proof housing. A hand screw conveniently located locks the gear at any desired position. A gauge and indicator show the distance saw blade is above table top. Blade may be lowered below the table top.

New Ripping Guide

This guide which is a rigid casting has a wood face and slides on a heavy steel bar graduated by fractions of an inch. The precise fitting of all component parts enables the operator to get very exact settings. A simple, rigid and accurate guide, easily adjusted.

Accessories

9B36	6" Dado complete: consists of.....	\$9.50
	2-1/8" outside saws, each.....	\$2.75
	1-1/4" Chipper	2.00
	2-1/8" Chippers, each	1.50
	1-1/16" Chipper	1.00
D56	5 1/2" Outside Saw (5/8" hole).....	1.10
D56A	5 1/2" Chipper (5/8" hole).....	.40
7B15	8" Cross-cut saw	1.65
7B15R	8" Rip Saw	1.65
7B20	8" Combination Saw	2.20
7B8	8" Hollow-ground Saw.....	3.95
MG70	Geared Self-Indexing Miter Gauge.....	2.50
7B14	Extension Tables (with long guide bar), Pr.....	6.50
7B25	Extension Bars (for front of table), Pr.....	1.50
PV450	4" V Pulley40
VB34	34" V Belt60
9P5	Motor base	1.50
G110	8" Cut-off wheel (for metal) 5/8" hole.....	1.10
G111	8" Cut-off wheel (for ceramics) 5/8" hole.....	1.10
SD85	Reversible steel Sanding Disc (with 2 abrasives) 1.50	
7200	Pkg. 6 Assorted Abrasive Discs75

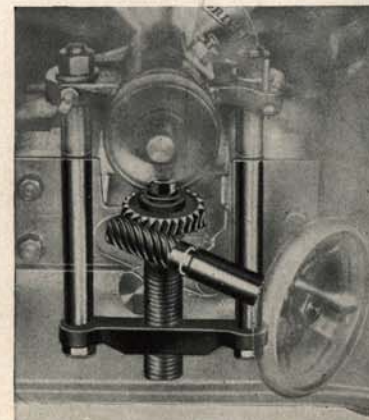

DRIVER D705

DRILL PRESS

Accessories

7D10 Mortising Attachment complete.....	\$2.50
7D11 Special Collet Chuck.....	.85
HC21 Hold down and Guide Complete.....	1.65
HC25 1/4" Hollow Chisel.....	1.30
HC25A 1/4" Bit.....	1.25
HC37 3/8" Hollow Chisel.....	1.30
HC37A 3/8" Bit.....	1.25
HC50 1/2" Hollow Chisel.....	1.30
HC50A 1/2" Bit.....	1.25
D Grinding Shape for Sharpening Chisels.....	.85
9D5 Threaded Adapter (for shaper cutters).....	.85
TD117 Drill Selector with 8 Drills.....	1.40
516 Jack Shaft Complete	2.75
VB39 Belt for Direct Drive.....	.60
VB86 Belt for Countershaft Drive.....	1.25
EL5 Driver Flexo Lamp.....	1.50
DS30 3" x 1" Sanding Drum.....	.85
DS20 2" x 1" Sanding Drum.....	.65
DS15 1 1/2" x 1" Sanding Drum.....	.35

(Extra abrasive belts for sanding drums listed on Page 28.)

This "700" Drill Press is heavier than the "500" model and has greater capacity. It is somewhat lighter than the "900" model and has less capacity.

It is built with mechanical precision never before associated with tools of its price class. It is exact enough to do the finest and most delicate drilling job, yet sturdy enough to stand up under the severest grind of daily shop production. No commercial drill press can boast of closer tolerances than the "700" model has.

Besides drilling it will do hollow chisel mortising. Although it is not recommended for daily production shaping, carving, routing and dovetailing it will fill the needs of the average home craftsman on these jobs—and do the work accurately and efficiently. The head may be inverted for shaping, as with the "900" Drill Press. A certain amount of shaping may be done with the head in its normal position. The 9D5 adapter is used for shaping, the collet chuck 7D11 for the other operations.

8 Speeds Available

The four-step motor pulley drives to a two-step pulley on the spindle. Thus eight speeds are available—a valuable feature in doing work of varied character.

Features

Jacob's Key Chuck regular equipment.

Chuck capacity 1/16" to 1/2" drills.

Maximum distance chuck to table 11 1/2".

Maximum distance chuck to base 17".

Distance center of chuck to column 6 1/2".

Table 9" x 8", base 9" x 8". Diameter of steel column 2".

Spindle travel 3 1/2".

Spindle 5/8" diameter, tapered at end for Jacob's Chuck.

Bearings oilless bronze.

Idler for countershaft drive available extra.

Height over all 38".

8 Speeds 1000-1300-1450-1800-1900-2300-2400-3000 R.P.M.

Motor of 1750 R.P.M. recommended.

Shipping weight (without motor) 90 lbs.

Through various steps of manufacture and after final assembly every DRIVER Drill Press is inspected and tested. Here, concentricity of the chuck is being checked. The delicate gauge used indicates the slightest deviation of the chuck from its true position.

The illustration at the right shows the mortising attachment in use with the countershaft drive. Either countershaft or direct motor drive may be had. The C40 Clutch makes a handy addition enabling the operator to stop the drill press without stopping the motor.



Design Patent No. 91,091

Including 72 Page Book of Instructions

\$23.45 as shown
less motor

Superior Motor Mounting

This DRIVER feature is deserving of special consideration. It enables the operator to change speeds quickly and easily. No tools are required, all controls being hand operated. The motor base is mounted on a heavy steel shaft extending into the head casting. To tighten the belt the assembly is simply slid out further. In changing speeds the pulley grooves are aligned by screwing the top hand wheel up or down as required. In this way eight speeds are obtained.



D706 Same as D705 except that idler unit and 86" belt are used instead of motor table and 39" belt \$24.45

DRIVER BN725

12" BAND SAW

The graceful lines . . . smooth action . . . and enduring power of a thoroughbred are apparent in this newest and greatest of DRIVER bandsaws. And truly it is a thoroughbred . . . in every sense of the word. It is made of the finest materials and is "groomed" through every step of production.

Regardless of whether you now own a band saw or not . . . look this new one over! It is an excellent specimen of what modern engineering and closely coordinated manufacturing effort can accomplish.

The Most Completely Equipped Band Saw Built

Guards, ripping guide and table extension are regular equipment making this the most complete 12" band saw built.

Read over its specifications, see it in action—then compare it to any 12" band saw on the market! Such comparison will show you—better than any other way—just how superior the DRIVER band saw really is. How much extra value there is in a DRIVER built tool!

The fine cutting qualities of the DRIVER "700" band saw are apparent in all kinds of work, whether it is hogging its way through a 4" walnut butt or cutting light stock. You can cut a perfectly straight line if you want to—the new guide will help you there. Or you can make the beautiful curves and graceful cuts for which a band saw is primarily intended. Any work you care to give it will be done easily, quickly and smoothly.

Sanding of intricate designs is easily accomplished with the sanding belts which may be slipped on in place of the saw blade. Metals and compositions may be cut efficiently with the metal cutting blade.

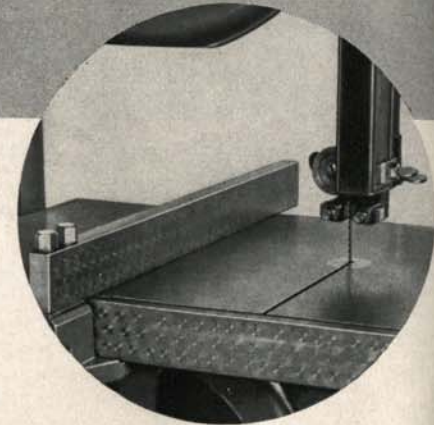

The rippling guide, a new DRIVER development, is indispensable in cutting straight lines.

Accessories

7BN17	3/16" Band Saw Blade..	\$1.00
7BN19	5/16" Band Saw Blade...	1.00
7BN20	1/4" Band Saw Blade...	1.00
7BN62	1/16" Band Saw Blade...	1.00
7BN21	Metal Cutting Blade....	1.00
7BN35	Spec. Blade for brake Lining	1.00
EL5	DRIVER Flexo Lamp...	1.50
VB42	42" Endless "V" Belt...	.75
PV25	2 1/2" "V" Pulley.....	.30



\$29.95 as shown

Including 72 Page Book of Instructions

Features

Cast iron frame, tubular construction.
Diameter of disc wheels, 12". 2 SKF Bearings to each wheel.
Wheels balanced and rubber faced.
6 SKF Ball Bearings.
Maximum distance upper guide to table 6".
Improved cushion type spring tensioner.
Table tilts to 45° (geared control mechanism).

Table size 12 1/2" x 12" (with wood extensions 18" x 12").

Ball bearing guide rollers (upper and lower).

Opening small guard between upper and lower guards increases capacity above 12".

New guide pins twist blade slightly, permitting stock up to 4 1/2" wide of any length to be sawed.

Height over all 33 1/2".

Shipping weight 103 lbs.

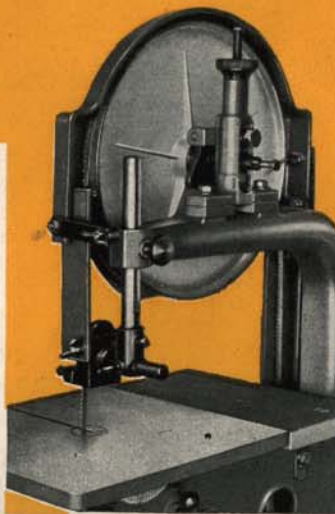

Tilting Table

Note the sturdy construction of the table and tilting mechanism. No light-weight stampings here to give and bend. The hand wheel at the left (with gear) tilts the table, the one at the right locks it in position.

Extra Capacity

Reversing the position of the ingeniously designed guide pins in the guides puts a slight twist in the blade at point of cutting, making it possible to saw stock of any length up to 4 1/2" wide.

Ball Bearing Guides

The thrust of the saw blade is absorbed by SKF ball bearing guides, or blade supports, above and below the table. Guide brackets are fully adjustable. An extra guard extending from upper wheel guard to the guide, moves with guide.

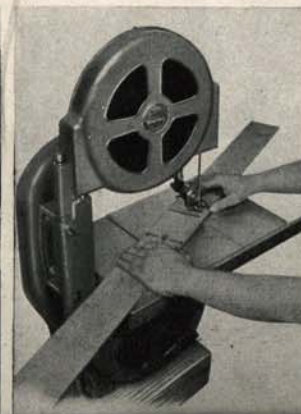
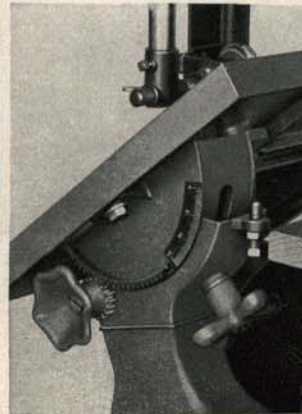

DRIVER J724

24" JIG or SCROLL SAW

FILING

Accurate metal filing may be done on this jig saw. Bearings are protected from fine metal particles by cotton boot. Six machine files of various types are available.

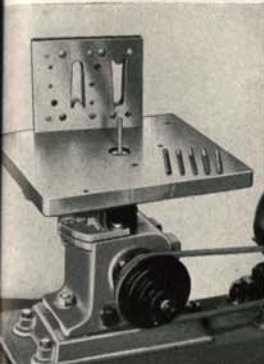

SANDING

With an ordinary dowel pin wrapped with sand paper finished sanding is done.

SABRE SAWING

With the arm removed, block letters and window displays are easily cut out.

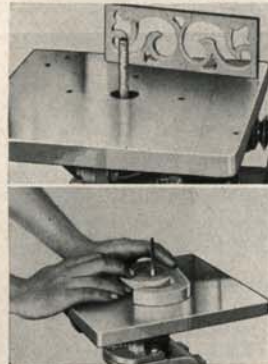

MACHINE FILES

Made of finest quality file stock, carefully heat treated. They will do accurate work over a long period of time. The selection of shapes covers practically all average requirements.

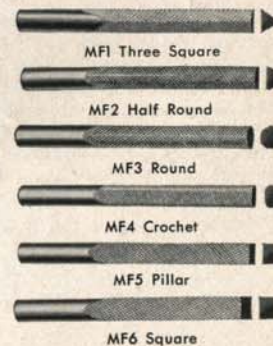

MF1 Three Square

MF2 Half Round

MF3 Round

MF4 Crochet

MF5 Pillar

MF6 Square

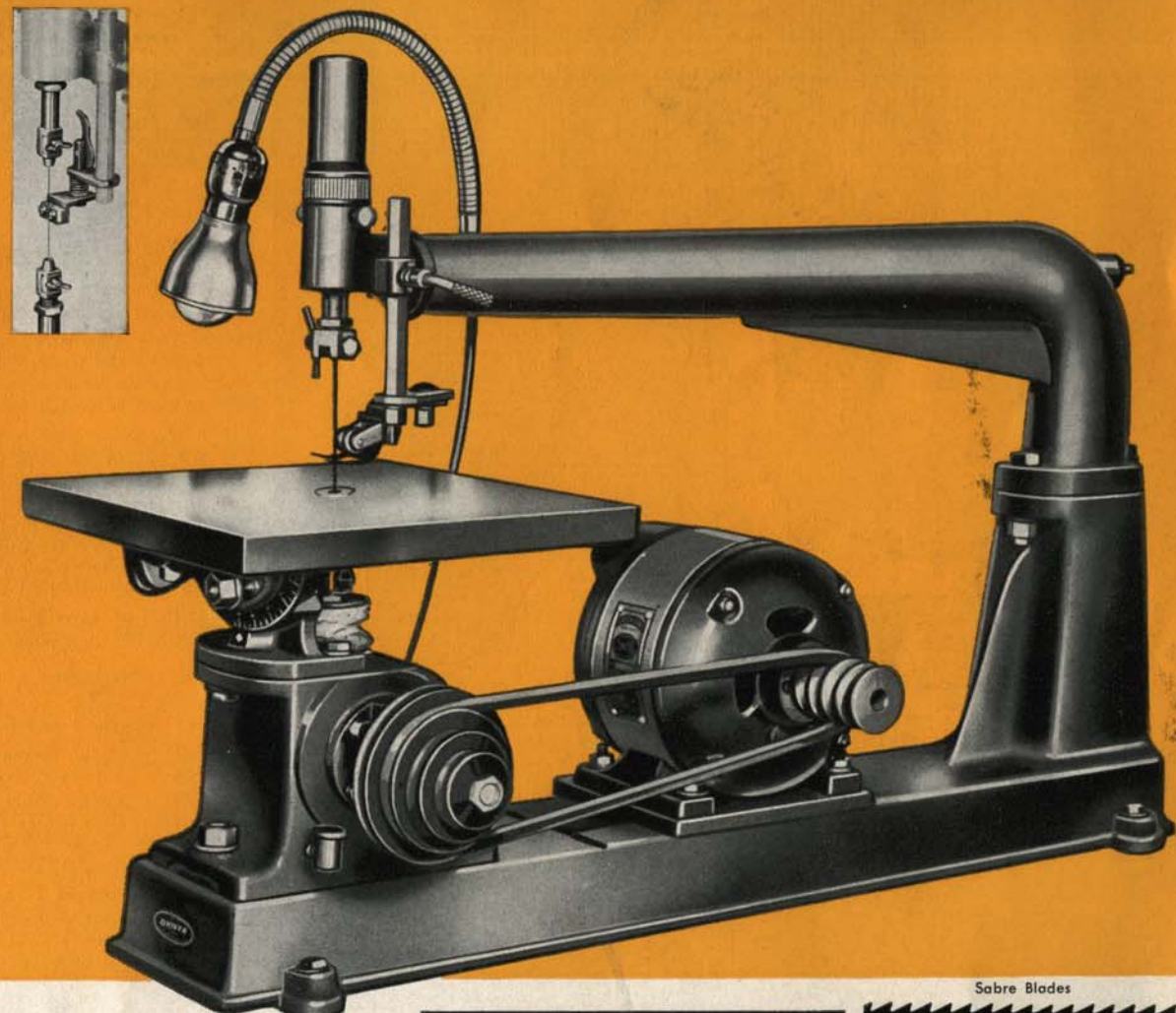

When this tool went on the market it set a new standard of values—a standard that has never been equalled. Thousands of owners—craftsmen and puzzle manufacturers—will tell you it is the finest machine of its kind built. Certainly no other one has a greater variety of uses or performs smoother or more efficiently. In flexibility of operation, selectivity of speeds, breadth of utility and in-born stamina it is unsurpassed. The perfect balanced movement of all working parts, the smooth feeling of power, its keen effortless cutting—all appeal to the man who admires quality tools!

Jig sawing, filing, sabre sawing and sanding can all be done with this machine. It meets the requirements of daily production work as well as home workshop use. Every type of jig sawing from the most delicate scroll work to cutting heavy pieces is done easily, quickly and safely.

The Model J-724 Saw has a throat capacity of 24" with the arm in place. The arm may be removed for sabre sawing, filing or sanding, affording unlimited capacity. Movement of the motor for purposes of belt adjustment is done by loosening a single nut at the rear of the motor base.

Accessories

PV34 1 3/4" Four-groove Pulley.....\$.55	EL5 DRIVER FLEXO LAMP..\$1.50
PA6 Puzzle Hold Down (See insert main illustration) 1.10	MF1 2, 3, 4, 5, 6 Files, ea..... .50
PA7 Set of Puzzle Vises..... 1.10	VB29 29" V Belt..... .60

Including 72 Page Book of Instruction

\$21.95 less motor including lamp

Features

- Throat capacity 24".
- Table 10 3/4" x 10 1/2", cast iron carefully ground.
- Distance upper vise to table 2 1/4".
- Table tilts to 45°, has indicator.
- Positive blower in head.
- Height over all 21".
- Length over all 32".
- Splash system of oiling.
- Special four-groove pulley (1 3/4" dia.) supplied, also belt.
- 4 speeds, 765-940-1225-1750 R.P.M.
- Universal chuck holds round, flat or angular sections.
- Spring Hold-down prevents work being lifted on up stroke of blade.
- Shipping weight (without motor) 115 lbs.

FRET AND JIG SAW BLADES		Thickness	Teeth	Length	Price	
No.	& Width	per in.				
14B	.008x.035	21	5"	\$.35 doz.	Fret Saw for wood—veneer, plywood, etc.	
13B	.010x.045	18	5"	.35 doz.	Fret Saw for wood—veneer, plywood, etc.	
6J	.017x.035	32	5"	.25 doz.	Jewelers—for metal, hard substances, wood	
75J	.016x.054	30	5"	.35 doz.	Jewelers—for metal, hard substances, wood	
6M	.022x.073	32	6"	.40 doz.	Jig Saw for metal only up to 1/8" thick	
14J	.020x.072	15	6"	.40 doz.	Jig Saw for metal over 1/8" and wood, etc.	
620	.020x.110	20	6"	.40 doz.	Jig Saw for general purposes, wood, metal	
615	.020x.110	15	6"	.40 doz.	Jig Saw for general purposes, wood, metal	
610	.020x.110	10	6"	.40 doz.	Jig Saw for general purposes, wood, metal	
410	.028x.187	10	6"	.90 doz.	Jig Saw for thick stock—wood	
420	.028x.250	20	6"	1.00 doz.	Jig Saw for thick stock—wood, metal	
407	.028x.250	7	6"	1.00 doz.	Jig Saw for thick stock—wood	
316	.040x3/16"	9	6"	.10 ea.	Sabre Blade—wood	
516	.040x5/16"	9	6"	.10 ea.	Sabre Blade—wood	
S19	.022x5/16"	20	6"	2.75 doz.	For cutting steel	
FB9	.042x5/16"	9	6"	1.65 doz.	Flexible back for cutting brake lining	
SB6	.040x7/16"	—	6"	2.25 doz.	Serrated edge for cutting paper and cloth	



S776 same as S775
but with 21"x15" table
\$24.95



\$19.95 less motor and
motor pulley
With 10"x14" Table (Including
72 Page Instruction Book)

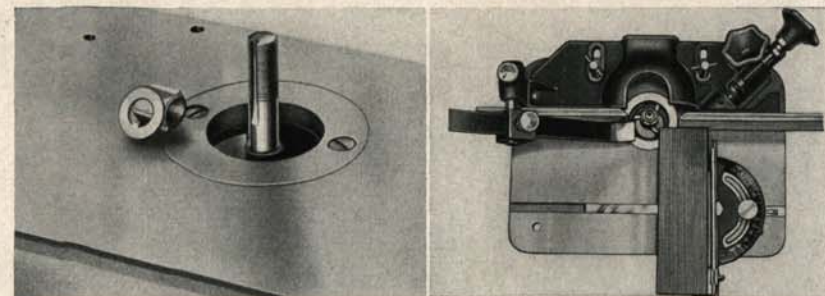

The spindle of the DRIVER shaper is keyed to permit operation in either direction. The keyed washer used between cutter and lock nut prevents loosening of the cutter.

View from top showing end of stock being shaped. Note the B11 miter gauge is used for guiding. Use of the miter gauge promotes accuracy and safety.



DRIVER S775 VERTICAL SPINDLE SHAPER

You may have figured that the spindle shaper is a machine you could get along without. But once you hear this new machine with its business-like hum, and see it carving mouldings and decorative frames as if by magic, you will want one. Its almost uncanny ability to cut varied attractive designs from a plain piece of lumber will thrill anyone.

This is by no means an ordinary shaper. It is a superior machine . . . from the SKF Ball Bearings to the worm gear mechanism for raising and lowering the spindle assembly. Every one of its many features is an important one from the standpoint of utility and convenience. Almost every feature is worth the cost of the entire machine.

To be efficient, a high-speed shaper such as this must have good bearings . . . so SKF's, the highest priced bearings made, carry the spindle. To be accurate it must be correctly designed and the component parts heavy . . . so we use only heavy gray iron in the base and table, steel elsewhere. To be convenient it is essential that adjustments be simple and done wherever possible without wrench or other tool . . . so this shaper carries more hand wheel adjustments than any other shaper we know of. Every possible factor that ingenuity could devise has been incorporated in this shaper . . . for just one purpose . . . to enable you to get greater efficiency, accuracy and satisfaction in shaping.

Call at your local DRIVER Store and see this new high-speed vertical shaper in action. Its remarkable performance will impress you.

Accessories

SS7	Guard and Guide	\$2.75	SS18	Shaper Cutter 1/2" hole.....	\$1.00
SS8	Set of Spring Hold-downs.....	1.50	SS19	Shaper Cutter 1/2" hole.....	1.00
SS5	Fluting Cutter50	SS20-21	Set of 2 Matched Tongue and Groove Cutters (1/4")	2.00
SS6	Corner Rounding Cutter.....	.50	SS22	Straight Face Cutter.....	1.00
SS7	Cove Cutter50	SS25	3/4" Straight Face Cutter.....	.90
SS8	Corner Rounding Cutter.....	.50	SS26	1/2" Straight Face Cutter.....	.90
SS9	Cove Cutter50	SS28	Table and Rule Joint Bead Cutter.....	1.00
SS10	Straight Face Cutter.....	.50	SS29	Table and Rule Joint Cove Cutter.....	1.00
SS11	Corner Rounding Cutter.....	.50	SS50	Depth Collars (large) 1/2" hole.....	.60
SS12	Surface Bead Cutter.....	.50	FS411	Sanding Drum with 2 belts.....	1.10
SS14	Set of Depth Collars (for small cutters, 5/16" hole)30	B11	Miter Gauge	1.00
SS15	Panel Knife85	(For the Shaper we recommend the 1/2 H.P. 3500 R.P.M. Motor with reversing switch and PV4 pulley. If 1/3 H.P. 1750 Motor is used motor pulley should be 6 1/2" dia.)		
SS16	Shaper Cutter 1/2" hole.....	1.00			
SS17	Shaper Cutter 1/2" hole.....	1.00			

DRIVER Shaper Cutters Are Excellent Quality

All cutters are made from selected tool steel, accurately ground and tempered. This type cutter is by far the safest to use as it is made in one piece. Thus the hazard of separate knives loosening up is eliminated.

Rigid Factory Tests

The importance of the shaper spindle being exactly at right angles with the table is apparent. Strict standards of accuracy are adhered to in manufacturing the DRIVER Shaper. Finally, after all inspections are finished, the machine is started and run before packing. Every possible precaution is taken to assure perfect satisfaction in the hands of the owner.



SHAPES MOULDINGS and EDGES of TABLE TOPS

Decorative edges which add so much to table tops are easily cut to shape in an almost endless variety of designs by the spindle shaper. Mouldings, picture frames and countless similar items are made with equal facility on this unique creative machine. With the proper cutters, tongue and glue joints are easily made. With a drum sander attached the shaper becomes a very efficient sanding machine. Taken all in all, this new shaper combines utility and efficiency to such a remarkable degree that no craftsman can long afford to be without one.

The DRIVER Shaper may be driven from a motor direct (as shown in main illustration on opposite page) or from a countershaft as shown below. Use of the RX10 Reversing Switch for reversing the direction of rotation of the motor and consequently the shaper spindle will extend the utility of the machine. The unusually efficient guard and guide offers full protection to the operator. All adjustments are in convenient positions.

The heavy duty SKF Ball Bearings are sealed in dust-tight cases and require practically no attention whatever. Reversing the position of the spindle for using the other diameter cutters is done by simply inverting the whole head assembly. It is not necessary to remove the bearings. The bearing housing is heavy cast iron carefully machined. Unusual stability is built into every part of this shaper so that years and years of high-speed service will not diminish its accuracy or efficiency.

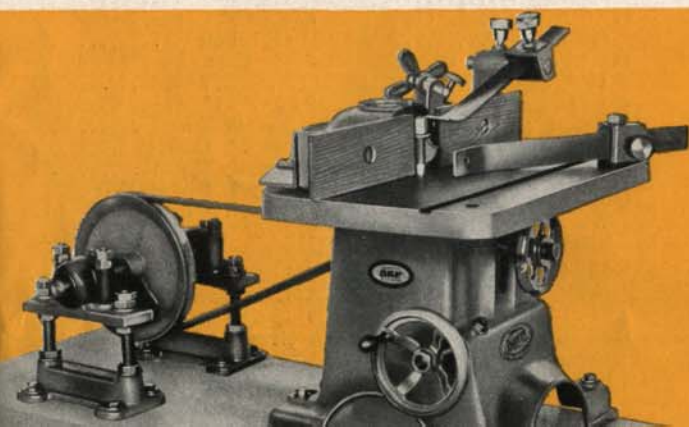

Features

- Table 14" x 10", machined cast iron.*
- Spindle raises and lowers 1 1/4".
- SKF Ball Bearings.
- New type guard and guide offers full protection and great ease in adjustments.
- Spindle diameters, 5/16" at one end to take small cutters, 1/2" at other end for larger cutters.
- May be operated in either direction.
- Spring hold-down and side clip hold work firmly against cutter.
- Fine screw adjustment of front guide.
- Spindle inverted without removing bearings.
- Spindle raised and lowered by precision worm gear.
- Available for direct or countershaft drive.
- Height over all 15 1/2".
- Operating speed 6000-8000 R.P.M.
- Shipping weight (without motor) 64 lbs.

(*Available with 21" x 15" table at extra cost.)

Direct Motor Drive

The chief advantage of this drive is in the fact that it eliminates twisting of the belt. Other features are ease of belt adjustment, and convenient shifting of the motor pulley to align it with the shaper pulley.

Reversing Feature

The advantages in being able to reverse the cutters on a spindle shaper are recognized by everyone who has done shaping. When shaping across the grain there is often a tendency to split off a piece of stock at the end of the cut. This can be avoided by inverting the cutter and the stock after the cut is partially completed and starting the cut again. With the DRIVER Shaper, cutters may be used with either end up, the reversing switch changing the direction of the motor. The keyed spindle with a key washer placed between the cutter and the lock nut effectively prevents the cutter from loosening.

Hold-Down Clips

These hold-downs of spring steel are especially helpful in shaping small stock. The one attached to the table presses the piece against the cutter while the other holds it down. Each hold-down has two adjustments, one to alter the degree of extension and the other to change the angle of the spring.

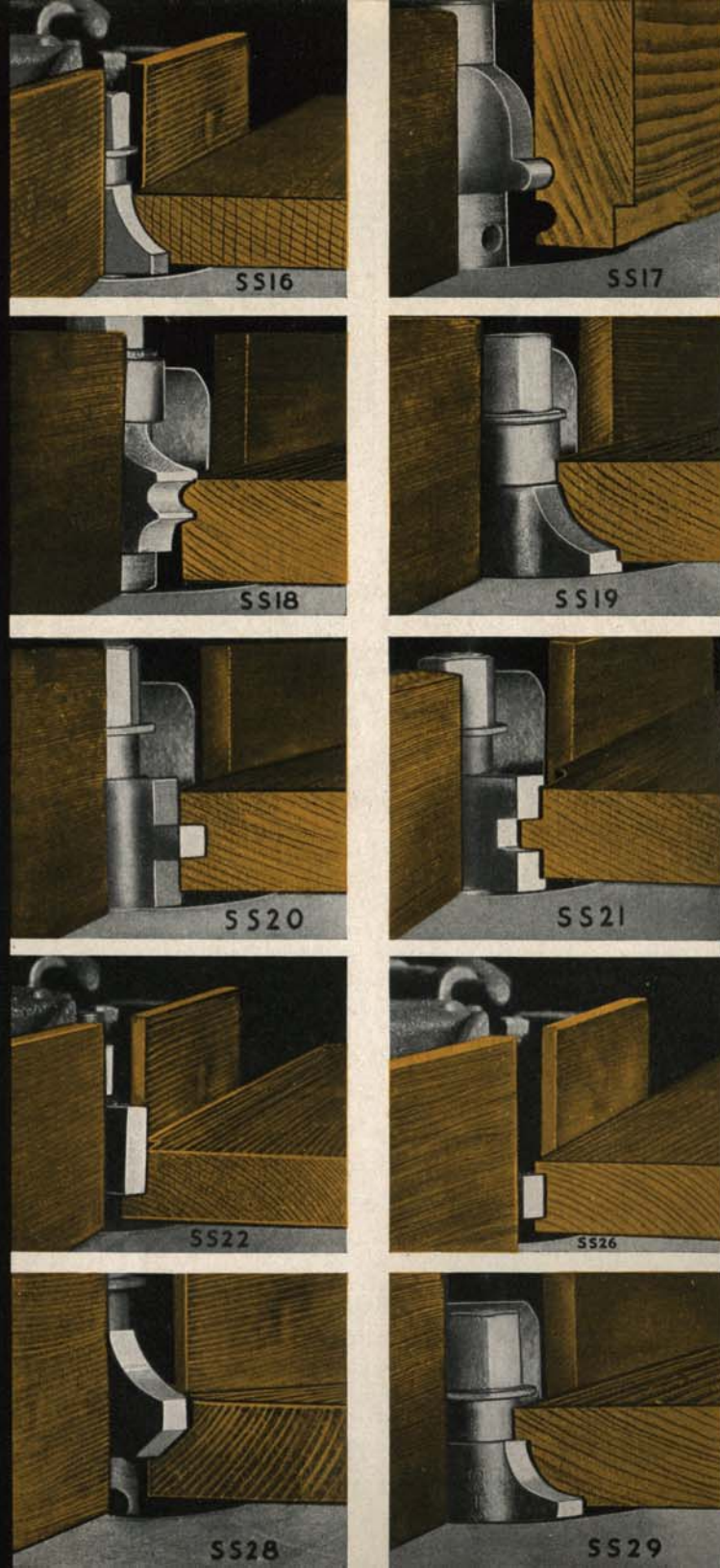

DRIVER BENCH GRINDER



G 5
4"
Bench
Grinder
\$2.00

6" Grinder

This tool (illustrated top center) is built for daily production work yet its price is so reasonable that every home craftsman will want one.

Bearings are bronze, $\frac{5}{8}$ " diameter with grease reservoirs. Turn-down grease cups supply positive lubrication. Shaft is turned down at ends to $\frac{1}{2}$ " diameter to take all standard DRIVER accessories. Adjustable tool rests and guards are so arranged that they function equally well with 4" and 6" diameter wheels.

This grinder is so designed that it may be driven from below, behind or above with a V, round or flat belt, by changing pulleys. Sufficient clearance is left between bearings to accommodate a flat belt pulley. A $1\frac{3}{4}$ " V pulley is furnished as regular equipment. Heavy, accurately ground collars for wheels are also supplied. Wire scratch wheels or cloth buffing wheels may be used instead of grinding wheels for rust or paint removing, polishing and buffing.

4" Grinder

A sturdy bench grinder at an exceptionally low price. Bearings are $\frac{5}{8}$ " in diameter. Two 4" x $\frac{3}{4}$ " grinding wheels are supplied. May be driven from above, below or behind.

Cut-Off Wheel

Attached to frame of G10 Bench Grinder it enables you to cut steel, iron, brass and copper rods, tubing, springs, etc., quickly and economically. Also for fast, accurate cutting of tile, brick, terracotta and similar substances. Set includes an 8" x $\frac{3}{32}$ " wheel for metal only, housing for wheel, bracket with "V" shaped vise to hold work, and all parts for attaching.

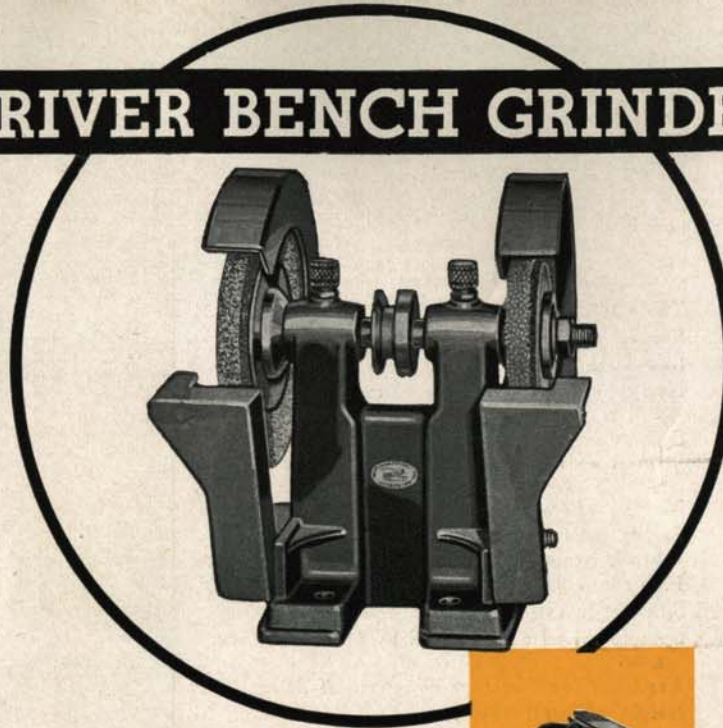

No. G-10A
\$4.75

As shown above

No. G-10
\$2.75

Same as above but less wheels



G-15

Cut-Off Attachments

G105	Guard for Cut-off Wheel.....	\$1.10
G106	8" Cut-off wheel (for steel and metals).....	1.10
G107	8" Cut-off wheel (for tile and ceramics).....	1.10
G108	Clamping attachment with bracket.....	1.10
G109	Eye shield (non-shattering glass).....	.85
G15	Cut-off unit as shown, including base.....	5.90

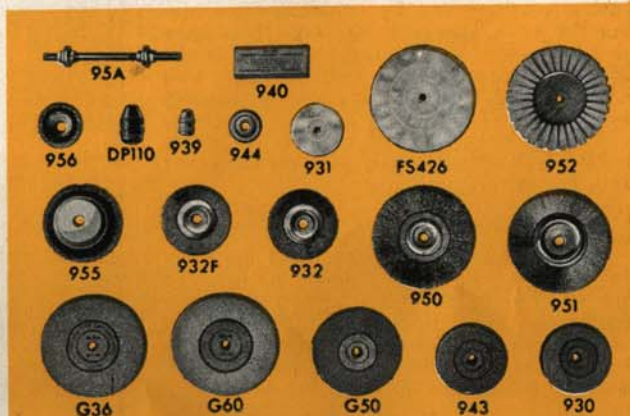

95A Spindle
956 DP110 939 944 931 FS426 952
955 932F 932 950 951
G36 G60 G50 943 930



94A
Polishing
Head
85¢

Polishing Head

With its numerous accessories this tool is handy for sharpening tools, removing rust and paint, grinding and polishing metals, and drilling. It provides an excellent and permanent set-up for grinding wheels which are used so frequently in sharpening tools.

Grinding wheels, wire scratch and cloth buffing wheels, drill chuck, Tampico brush, waxing brushes and other accessories with $\frac{1}{2}$ " holes can be mounted on the polishing head.

Driven by endless "V" belt. The $\frac{1}{2}$ " spindle is fitted with a nut and lock nut at each end, one set being right hand threads the other left.

May be driven by a round belt by simply substituting a round belt pulley for the "V" which is supplied regular equipment.

Accessories

95A Polishing Spindle.....	.30	931 3" Cotton Buffer ($\frac{1}{2}$ " hole).....	.30
939 Drill Chuck ($\frac{1}{4}$ " cap.).....	.30	FS426 6" Cotton Buffer ($\frac{1}{2}$ " hole).....	.50
DP110 Drill Chuck ($\frac{1}{2}$ " cap.).....	.85	932 Coarse Wire Scratch Wheel.....	.55
930 4" x $\frac{1}{2}$ " Grinding Wheel ($\frac{1}{2}$ " hole)...	.40	932-F 4" Fine Wire Scratch Wheel.....	.85
943 4" x 1" Grinding Wheel ($\frac{1}{2}$ " hole)...	.55	950 6" Coarse Wire Scratch Wheel.....	.85
G-50 5" x $\frac{1}{2}$ " Grinding Wheel Fine ($\frac{1}{2}$ " hole).....	.70	951 6" Fine Wire Scratch Wheel.....	1.10
G-36 6" Coarse Grit Grinding Wheel ($\frac{1}{2}$ " hole).....	1.10	952 6" x 1" Tampico Brush.....	.85
G-60 6" Fine Grit Grinding Wheel ($\frac{1}{2}$ " hole).....	1.10	944 Flange Washer....	.05
		940 Buffing Compound	.30
		955 4" Wire Cup Brush.....	1.10
		956 $\frac{3}{4}$ " Wire Cup Brush.....	.85

Introducing THE DRIVER "Series 900" LINE

To those who can be satisfied only with the best, the "900" Series Tools will instantly appeal. Their extra weight, unique conveniences, extended uses and floating motor drives will win enthusiastic acclaim from every man who admires quality tools. Judged from every angle—they represent new and greater value.

All the "900" Tools are equipped with SKF Ball Bearings, recognized the world over as the finest bearings made. Every machine with the exception of the jointer may readily be adapted to various types of work. For instance, the drill press can be used for mortising, carving, routing, shaping and dovetailing, as well as for drilling. The saw has accessories available for cutting steel, tile, brick and similar substances, as well as wood,

and the massive lathe may be used either for wood or metal work. In every machine we have endeavored to provide unusual utility at the lowest possible investment. Already many of these tools are in use in some of the largest industrial plants in the country . . . doing steady production work . . . cutting operating costs . . . saving their owners money.

In selecting these tools for your shop you can be certain of unvarying precision and efficiency over a long period of years . . . even at full capacity on daily production work.

See them . . . in action . . . at your local DRIVER store. The dealer will gladly show you how efficiently the "900" tools complete the varied jobs for which they were built.



DRIVER L900 LATHE

FOR WOOD OR METAL TURNING

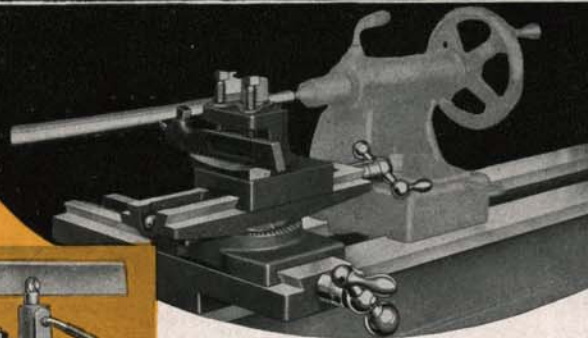

With the Compound Slide Rest Attached Accurate Metal Turning can be done.

This lathe was designed and built to meet the exacting requirements of commercial pattern makers and advanced craftsmen and mechanics who know and demand the best in a wood turning lathe. On first inspection you will agree that it is distinctly in a class by itself. Its unusual capacity, extreme accuracy and outstanding quality will appeal to those who derive extra satisfaction from owning the best that can be bought.

Metal Working

With the compound tool rest shown at the left many kinds of metal working such as turning and boring, straight or taper, can be done with great accuracy.

The compound slide rest clamps directly to the bed of the Series 900 Lathe. All sliding surfaces are precision-fitted insuring smooth, positive and accurate action in all positions. It may be set at any angle on the horizontal plane, moved towards and away from the head stock (longitudinally) and crosswise of the bed (transversely). Distance of longitudinal feed 6 inches, transverse, 7 inches.

This attachment working in connection with the Morse tapered spindles and Jacob's Key Chuck of the DRIVER Lathe form a rare combination for the man of moderate means. Equipment of this type has never before been available at such reasonable cost.

The home craftsman, garage man, owner of a manufacturing plant or industrial concern will find this outfit perfectly satisfactory for light work. In the service station valves can be trued, bushings and other parts turned down, armature commutators turned down, coil springs wound and dozens of other jobs performed. The home craftsman has new opportunities to turn metal novelties and spin brass, copper or pewter.



Accessories

L375	1" Gouge Chisel (Heavy Duty)	\$ 1.10	*9L35	6 1/4" Face Plate (right thread)	1.65
L376	1/2" Skew Chisel (Heavy Duty)	1.10	9L36	24" Tool Rest with brackets	2.75
L377	1/2" Spear Point (Heavy Duty)	1.10	*9L37	Steady Rest, for small turnings	3.75
9L25	Spur Center (No. 2 Morse Taper)85	9L38	Swinging Bracket with support (less Tee)....	4.95
9L26	Cup Center for tail stock (No. 2 Morse Taper) ..	.85	9L39	12" Tee Rest only.....	1.65
*9L27	60° center for tail stock (No. 2 Morse Taper) ..	.85	*9LB15	Lathe Bench complete...	17.00
*9L28	Arbor (No. 2 Morse Taper) for Jacob's Chuck85	*VB42	42" V Belt (Heavy Duty) ..	.75
*9L29	Arbor (No. 2 Morse Taper) for grinding wheels, etc.	1.10	*VB34	34" V Belt (Heavy Type) ..	.60
*9L33	3" Face Plate with spurs and changeable centers.	1.65	*PV750	5 1/2" 4-step pulley (3/4" hole)	1.10
*9L34	6 1/4" Face Plate (left thread)	1.65	PV500	5 1/2" 4-step pulley (1/2" hole)	1.10
			*FL1	Floating Motor Base....	1.65

(Note all parts marked with * are also used for metal working.)

\$43.45 (Including 72 Page Book of Instructions)

WITH 12" TOOL REST INSTEAD OF 24" SHOWN (LESS FACE PLATE AND COMPOUND SLIDE REST 42" V BELT INCLUDED)

The "900" lathe combines the accepted principles of lathe design with massive construction and finest precision. While such strength may not be essential for woodworking, the owner of this lathe can rest assured that any time he wants to do metal turning or spinning all he has to do is to get the particular attachments for these operations. It will not be necessary to purchase a *new* lathe—the "900" model fills all requirements for doing these operations.

A full line of No. 2 Morse Taper spindles and arbors for holding the accessories used in turning, drilling, buffing, grinding and drum sanding are available. The head stock spindle which is unusually large in diameter is hollow (5/8" diameter hole). This feature permits the turning of arrows, dowel pins and similar rods of fairly large diameter in long pieces.

New Universal Chuck

This new chuck is exceptionally high quality, being made entirely of steel. It is used for machining metals of all kinds. Has two sets of jaws, one for inside chucking and the other set for outside chucking. It is self-centering and holds round or hexagonal pieces. Supplied complete with back plate for attaching.

Features

- Bed 54" long, gray iron carefully ground and polished.
- Distance between centers 37".
- Swing (diameter of work that can be turned) 10".
- Morse Taper centers (No. 2).
- Hollow head spindle, 5/8" inside diameter.
- Diameter of spindle between bearings 1".
- SKF Ball Bearings.
- 4 speeds (700—1300—2300—4200 R.P.M.).
- Tail stock has set-over for turning tapers.
- Head stock pulley has positive locking device to hold the turning stationary while being fluted or reeded.
- Height over all 14".
- Width of bed at top 6 1/2".
- Extra strength and rigidity throughout.
- Shipping weight 180 lbs.
- Motor recommended 1/3 H.P., 1750 R.P.M.
- (All spinning accessories listed on page 12 may be used on this lathe.)

It is the bed that makes the DRIVER "900" lathe differ radically from others. It

is not made up of light welded stampings, nor from standard steel sections, but from rigid cast iron which has passed through an aging process to insure permanent accuracy. The ways of the bed, on which the tool rest and tail stock slide, are first carefully machined, then aged, and finally machined again. The weight of the DRIVER bed is several times that of the average lathe bed of similar capacity. Another advantage is the three-point lugs for attaching the lathe to a bench. While other lathes with lugs placed only along the sides may become distorted when bolted to an uneven bench top, the DRIVER bed with its end fastening will not be affected by an irregular bench top.

The head stock spindle has a right hand thread and a left thread on the opposite end for large plate work, a separate face plate being supplied.

On this lathe the face plate fits very close to the bearing thus permitting heavy work to be handled without danger of springing the spindle.

Metal Turning Accessories

5L18	3/4" Lathe Dog.....	\$.55	9L42	Tool Wrench	\$.15
6A	Jacobs Key Chuck.....	6.75	9L43	High-Speed Steel Bit (not formed)10
9L30	3" Independent Jaw Chuck with back plate. 6.95		OB25	Bronze-bushed self-aligning hanger, ea.	2.95
9L31	Universal Chuck with Extra Jaws and back plate	12.75	OB26	Special 3/4" Shaft turned down to 1/2" at ends....	.85
9L40	Compound Slide Rest with tool post (not including 9L41)	13.90	RX10	Reversing Switch	2.95
9L41	Double O Tool Holder with High-Speed Steel Bit	1.60			

Metal Spinning

The L900 Lathe is ideally adapted to spinning metal. The necessary accessories are listed on page 12.

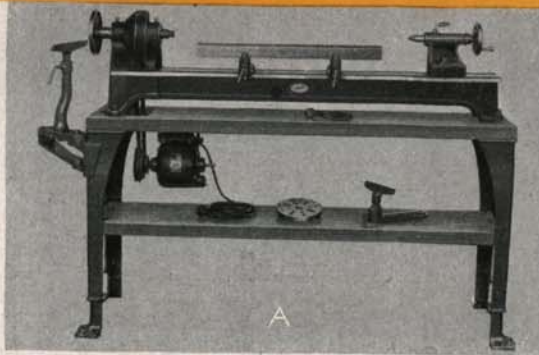

Photo A—Showing the "900" lathe mounted on the 9LB15 bench. This set up is for woodworking. Metal working requires the use of a jack shaft mounted on the lower shelf with the motor suspended below.



Photo B—This phantom view shows the interior parts of the tail stock. This is a self-ejecting center. When the sleeve is run back to its limit the center is ejected.

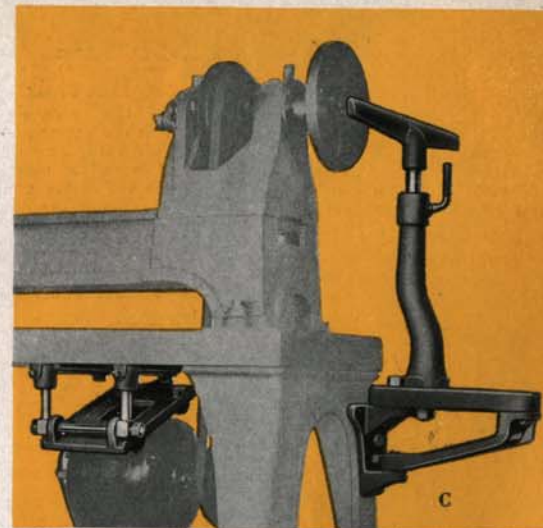

Photo C—The special swinging bracket for holding the tool rest from the outside for turning pieces of large diameter is very helpful in this type of work. Built very rugged, and is fully adjustable.

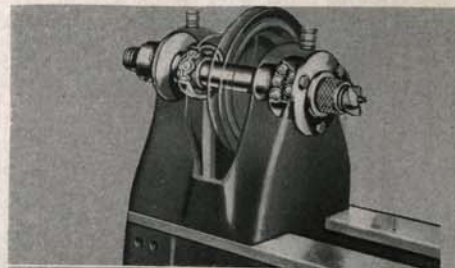

Photo D—Phantom shows how bearings are mounted in head stock. The SKF Ball Bearing at the front end, where the greatest load comes, is the double-row preloaded type. A single type is used at the other end. Note large diameter of shaft.

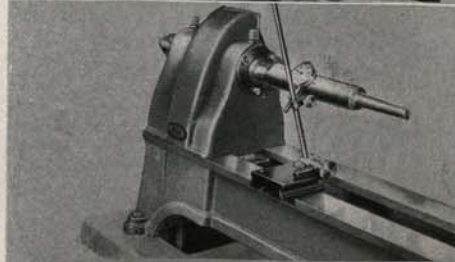

Photo E—Frequent tests are made during manufacture to assure utmost precision. Here a delicate gauge is used to check accuracy of the spindle. This will be recognized as a severe test, the reading being taken at a distance from the spindle. In this position any error is magnified. Following this test the tail stock (with center removed) is slid up to this test bar to check alignment of the tail stock with the head stock.

DRIVER 900 DRILL PRESSES

Bench and Floor Models (Including 72 Page Book of Instructions)



Mortising

Upper photo shows hollow chisel mortiser in use cutting square holes. Parts 9D4 and HC21, with the necessary bit and chisel, illustrated in accessory panel, are used.

Carving

Beautiful carvings can be made quickly and easily with the carving routers and collet chuck.

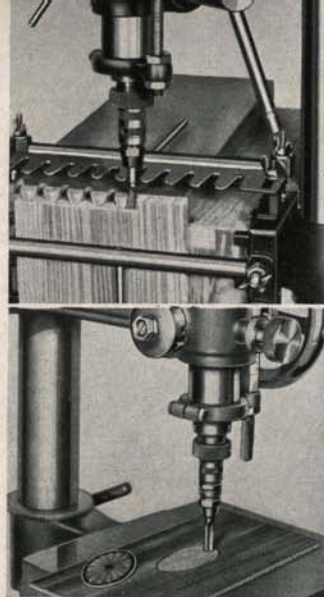

Dovetailing

With the unique attachment shown in the upper photo, dovetail joints can easily be formed. A perfect fit is assured since both members are cut at the same time.

Inlaying

The hardest part of inlaying—removing the wood to uniform depth—is done accurately and almost without effort on the drill press.



Tapping Holes

With the tapping attachment shown above, installed on the drill press, holes up to $\frac{3}{8}$ " may be tapped at speeds up to 3000 R.P.M. Reverse speed 6000 R.P.M. This is a very high quality tapping attachment, ball bearings being used throughout. Available on special order only.

Type	Cap. (steel)	Cap. (cast iron)	Price
1	0 to 3/16"	0 to 1/4"	\$35.00
2	0 to 5/16"	0 to 3/8"	50.00

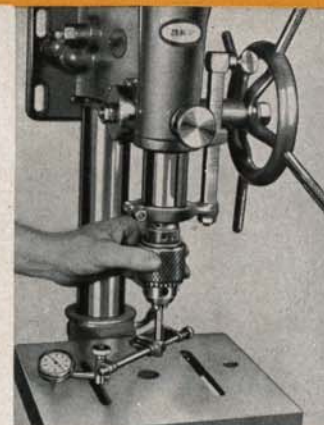

One of a series of tests to which every DRIVER Drill Press is subjected before leaving the factory. In this particular instance the flatness of the table being tested by swinging the delicate indicator, attached to the chuck, around and over the table surface. Any inaccuracy will be exposed and remedied.

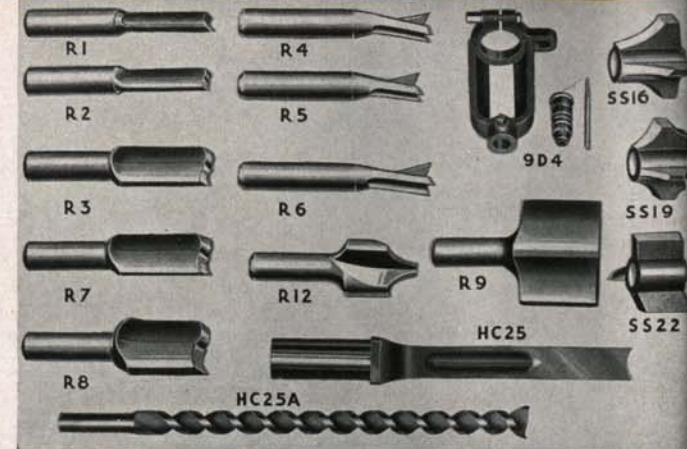

Accessories

TD117 Set of 8 Twist Drills in selector..	\$1.40
7D11 Special Collet Chuck.....	.85
5S7 Shaping guard and guide.....	2.75
5S8 Set of Spring Hold-Downs.....	1.50
9D3 Extension Table	2.75
9D4 Mortising Attachment complete.....	2.50
HC25— $\frac{1}{4}$ ", HC37— $\frac{3}{8}$ ", HC50— $\frac{1}{2}$ " Hollow Chisels, ea.	1.30
HC25-A— $\frac{1}{4}$ ", HC37-A— $\frac{3}{8}$ ", HC50-A— $\frac{1}{2}$ " Bits, ea.	1.25
HC21 Mortising hold down and guide..	1.65
D Chisel Grinding Stone.....	.85
DV10 Dovetail Jig Complete (incl. R6).	4.40
9D5 Threaded Adapter85
DP119 Nut05
R1 ($\frac{1}{8}$ "), R2 ($\frac{1}{4}$ "), R3 ($\frac{3}{8}$ ") Routers, ea.	.60
R4 ($\frac{1}{4}$ "), R5 ($\frac{3}{8}$ "), R6 ($\frac{1}{2}$ ") Dovetail Routers, ea.60
R7 ($\frac{1}{2}$ "), R8 ($\frac{5}{8}$ "), R9 (1") Mortising Routers, ea.90
R10 ($\frac{1}{2}$ "), R12 ($\frac{3}{4}$ "), Carving Bits, ea..	.90
SS16, SS17, SS18, SS19, Shaping Cutters, $\frac{1}{4}$ " dia. x $\frac{1}{2}$ " hole, ea.	1.00
SS20 $\frac{1}{4}$ " Groove cutter with $\frac{1}{2}$ " hole....	1.00
SS21 $\frac{1}{4}$ " Tongue cutter with $\frac{1}{2}$ " hole....	1.00
SS22 Straight Face Cutter.....	1.00
SS25 $\frac{1}{4}$ " , SS26, $\frac{1}{2}$ " straight face cutters with $\frac{1}{2}$ " hole, ea.90
SS28, SS29, Joint Bead cutters $\frac{1}{2}$ " hole, ea.	1.00
SS50 Set of depth collars with $\frac{1}{2}$ " holes	.60
DP120 Adapter for small cutters.....	.30
SS5 Fluting cutter50
SS7, SS9, Cove cutters (each).....	.50
SS6, SS8, SS11, Corner Rounding Cutters.	.50
SS10 Straight Face Cutter.....	.50
SS12 Surface Bead Cutter.....	.50
SS14 Set of Guide Washers, Depth Collars	.30

Floor Type Drill Press Has Many Advantages

Greatly increased capacity is obtained with the floor model. In the photo at the left a piece of stock 21" high is being drilled. You will note that this does not even tax its capacity. In fact a piece 46" long may be drilled by swinging the table to one side and utilizing the finished base for a table. Another advantage is the comparatively small amount of floor space it requires.

The extra capacity of the DRIVER Floor Model drill press is also of great assistance in hollow chisel mortising. Very often, in building furniture which requires mortises for strength the pieces are too large to be worked on a bench model.

The massive strength and stability of the DRIVER drill press . . . together with its precision parts such as the SKF Ball Bearings and Jacobs Key Chuck, and its conveniences such as the pilot wheel feed . . . assure you utmost satisfaction over a long period of time.

While floor type drill presses have been used mostly in production shops the DRIVER model is so reasonably priced that many home craftsmen will want one.

Outside of the difference in column length (the floor model is 60" long) and the resultant difference in distance from chuck to table and base, all specifications are the same as the bench model shown on opposite page.

All D-900 drill presses may be converted into floor models by substituting the new 60" column for the original one.



D922 Bench Model \$33.95 (not illustrated) (with idler and long belt)

D921 Floor Model \$35.45 (as shown less motor and drill)

D920 Bench Model

\$32.95 (as shown less motor and drill)

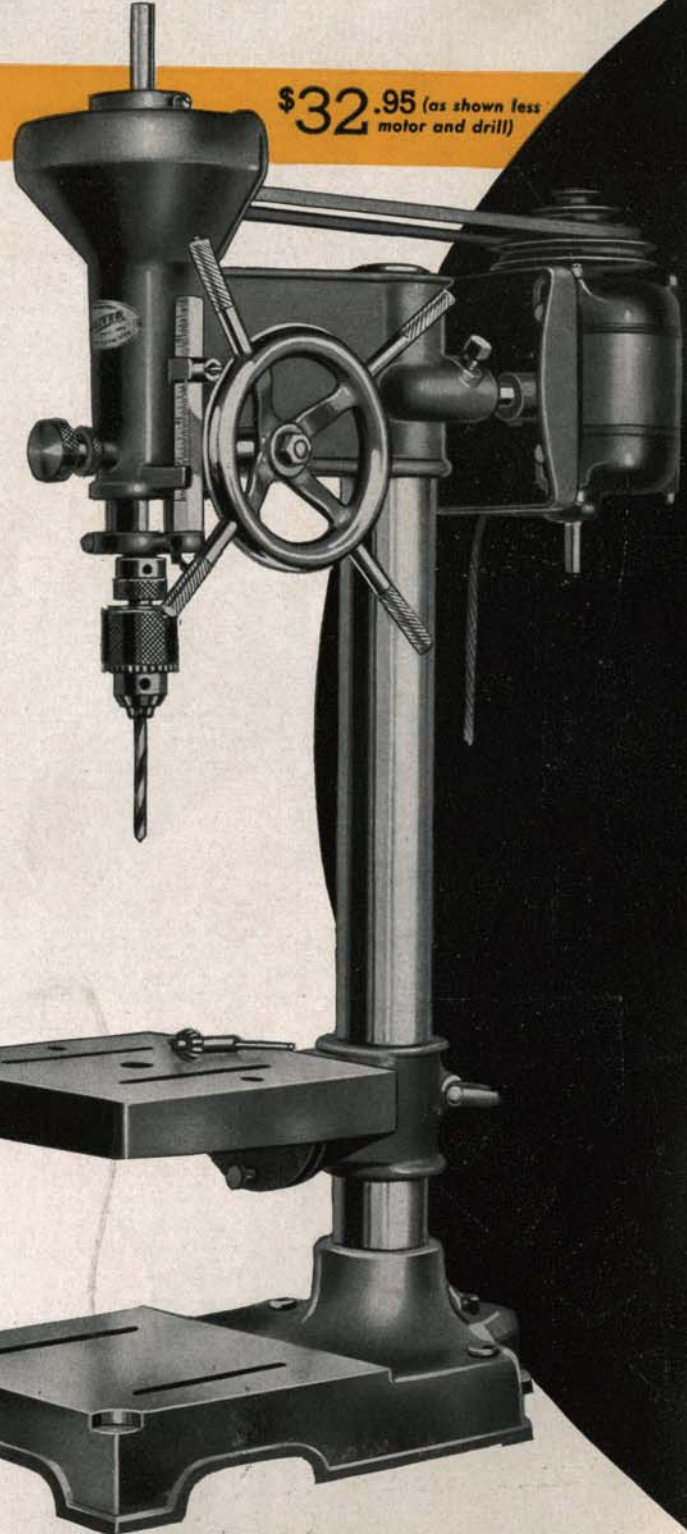
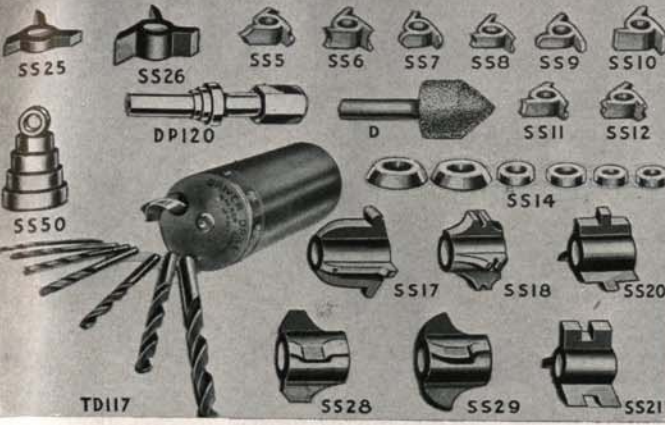

Features

- SKF Ball Bearings.
- Jacob's Key Chuck (0 to 1/2" drills).
- Drills to center of 15" circle (7 1/2" from center line of drill to column).
- Pilot Wheel Feed.
- Depth of cut (by fractions of an inch) indicated on square steel stop and depth gauge.
- Head close grained gray iron, extremely rigid. Belt guard is an integral part of head—with a ball-bearing at the top. Greatest distance chuck to base-table 17 1/2".
- Quill 1 13/16" diameter, steel ground to size. Teeth to match feed pinion are milled.
- Motor Drive, direct with easy belt adjustment. "V" Belt and pulleys.
- Spindle—accurately ground and fitted, lower end tapered for chuck.
- Locking device for holding quill in any position, very positive.
- Improved locking device for holding head on column.
- Speeds from 600 to 5000 with 1750 R.P.M. motor and from 1200 to 8000 R.P.M. with 3500 speed motor. 3 extra speeds obtained by shifting motor on bracket.
- Steel Column, 2 1/2" diameter.
- Two Tables, upper 10" x 9" adjustable to any angle. Lower table and base 10" x 9".
- Column may be shortened by dropping it through the base and bench.
- Collet Chuck available for holding mortising, carving, routing, and dovetail bits.
- Threaded adapter available for shaping.
- May be operated either direction for shaping with (RX10) Motor Reversing Switch.
- Recommend 1/3 H.P. motor for drilling, 1/2 H.P. motor for high speed operations.
- Shipping weight (without motor) 115 lbs.

To those who are satisfied only with the best, this new drill press will instantly appeal. Its impressive, modern appearance is evidence of the ingenious features and advanced design which make this superb tool an outstanding mechanical achievement. Work it day and night if you choose, at high speeds or low, give it every possible test for precision, crowd it or race it, as you will—the more you use it the greater will be your respect for it.

Many Craftsmen have been surprised by the superb performance of this remarkable machine, for the "Series 900" Drill Press has stability, accuracy and efficiency—to spare. The husky castings, the large S.K.F. Ball Bearings, the rigid steel quill and Jacob's Key Chuck are proof of that. Add to these its other outstanding features and you will understand why it is certain to be the unquestioned leader in its field.

It has long been the DRIVER policy to incorporate as many different uses as possible in a machine to extend its utility and thus enable its owner to do a maximum of operations at a minimum machine investment. This policy is well maintained in the "Series 900" Drill Press. With the proper attachments it does six separate jobs—and does them well. Drilling, shaping, routing, mortising, dovetailing and carving are all accomplished with excellent results. Driver pioneered this idea, and it has been widely copied, but the new 900 Drill Press—with greater capacity, new design and new refinements—will again show the way!

DRIVER B960 10" BENCH SAW

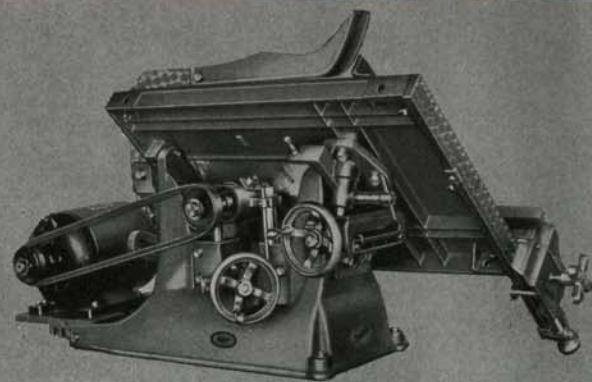

In designing and building this saw DRIVER engineers had just one goal in mind. That was to build the best and most serviceable portable saw yet developed for general use by mechanics and home craftsmen.

While this bench saw has more conveniences than the average machine of its type, none of them has been added for mere "sales appeal". Each feature and each convenience has a definite job to do, and it must do that particular job better than it ever has been done before. Every point has been studied and developed solely from the viewpoint of service to the user.

The weight of this saw greatly exceeds that of others selling in the same price range. Yet no material has been wasted—every pound is there for a definite purpose. We believe that the extra weight and sturdiness will be appreciated by every owner.

Guard and Splitter Regular Equipment

A real safety guard with splitter is standard equipment on every DRIVER saw. Many accidents can be traced directly to the fact that some guards, because of their efficiency, are considered a nuisance by the operator and discarded. The DRIVER guard is one you will prefer to use as it does not interfere in any way. It is a light metal casting and hinges on the splitter. It retains its same relative position regardless of the angle or tilt of the table. This guard is also adequate when abrasive cut-off wheels are employed.

To get the most out of this saw the $\frac{3}{4}$ H.P. 3450 R.P.M. motor is required. If saw blades of less than 10" diameter are used the motor may be of proportionately less horsepower. With an 8" blade the $\frac{1}{2}$ H.P. 3450 R.P.M. motor is sufficient and with a 7" blade the $\frac{1}{3}$ H.P. model will be satisfactory.

Cuts Full 3" Stock

With the 10" blade at the top position stock up to 3" thick may be cut. Few, if any, bench saws have capacity equal to this. Raising and lowering of the saw blade is done by the worm gear mechanism illustrated on next page.

Pat. Appl. For

Accessories

9B39	10" Cross-cut Saw	\$2.00
9B39R	10" Rip Saw	2.00
9B37	10" Combination Saw	2.75
9B10	10" Hollow-ground Saw	4.95
9B38	10" Abrasive cut-off wheel (for metal)	2.75
9B38A	10" Abrasive cut-off wheel (for ceramics)	2.75
G110	8" Cut-off wheel (for metal) 5/8" hole	1.10
G111	8" Cut-off wheel (for ceramics) 5/8" hole	1.10
9B75	Extension tables with long bar (pair)	8.25
MG90	Geared self-indexing Miter Gauge	3.00
PV275	2 1/2" V Pulley (with 3/4" hole)30
VB39	39" V Belt60
9B36	6" Dado Complete—consists of... ..	9.50
	2 1/8" Outside saws, ea.	\$2.75
	1 1/4" Chipper	2.00
	2 1/8" Chipper	1.50
	1 1/16" Chipper	1.00
SD85	8 1/2" Reversible Steel Sanding disc (with 2 abrasives)	1.50
7200	Pkg. of 6 Assorted Abrasive discs (for SD85)75

(Photo at left shows sanding being done, with table tilted.)



\$39.50 as shown. (Including 72 Page Book of Instructions.) Including new miter gauge, but without extension tables or motor

B961 Same as B960 but **\$47.75** with Extension tables

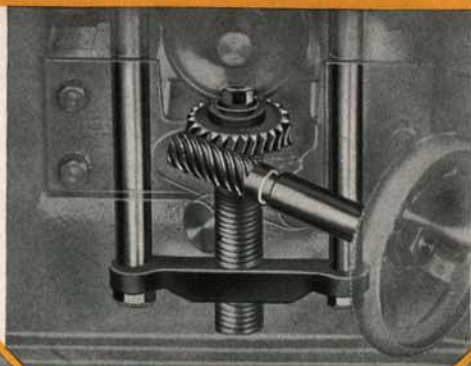
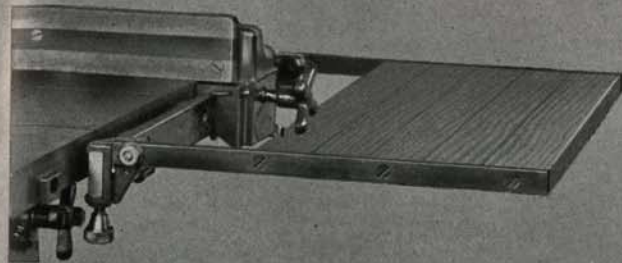

A DISTINCT achievement in design, this splendid new bench saw embraces features found in no other machine of its type. It will plow through 3" of rock maple with astonishing ease. As a tool for fine cabinet work, it will delight the most exacting craftsman. Practically every adjustment is made with micrometer accuracy. Its stability and permanent adjustments assure the exact duplication of parts so essential in fine cabinet work.

TABLE: Made of close-grained gray iron—heavily ribbed against warping. Top is carefully ground and polished. Length 21". Width without extensions 15", with extensions 31". Has two grooves for miter gauge. Tilts to 45° with movement controlled by worm gear. A feature, found on no other bench saw, is the "nested" table insert. This comprises a small insert which is removed for dadoing inside a larger one which is removed for disc sanding. The inserts may be removed singly or as a unit. A full length steel bar (calibrated in inches) for holding the ripping fence is supplied with the extension tables.

BASE: A heavy casting enclosed to prevent sawdust being scattered around. A smaller casting encloses the moving parts and is attached to the main base.

ARBOR: Machined steel, 3/4" in diameter at bearings. Size at blade 5/8". Pulley hole 5/8". Two SKF Ball Bearings carry the spindle. They are mounted in dust-proof housings and packed with sufficient lubrication for an almost indefinite period of operation. The arbor is raised and lowered by means of a cut steel worm and pinion, actuated by a hand wheel. The height of the saw, in relation to the table, is indicated by a pointer which is visible at all times.

TABLE TILTING DEVICE: One of the most unusual features of this machine. By turning the hand wheel the table is tilted to the smallest fraction of a degree. The tilting action is powerful due to the micrometer screw adjustment yet the action is smooth and easy, entirely without play.

RIPPING FENCE: Here again is a feature of unusual merit. Bolted to the face of this fence is a facing of laminated hardwood. This combination provides extra rigidity and at the same time prevents injury to the saw blade if the fence is accidentally brought into contact with it.

The fence slides along the table on a heavy steel support bar, the top of which is calibrated in fractions of an inch.

A convenience that will be greatly appreciated is the micrometer adjustment of the ripping fence. The fence is moved to its approximate position and the final adjustment made with the micrometer screw. It is easy to operate and positive in action.

Worm Gear Control

Here is a refinement which has unquestioned utility value. Slight pressure on the hand wheel raises and lowers the arbor assembly and saw blade. It is very positive and has no "lost motion". The above photo is a phantom view. All moving parts are thoroughly enclosed.

Front Extension Table

In cutting long strips of wood or such materials as wall board or plywood, some form of table extension is a great convenience. When not in use it should be readily removable.

These new DRIVER extension arms permit the construction of an inexpensive table extension. Strips of wood or wooden rollers can be placed between the arms according to the width desired.

Table Tilting Mechanism

The table is tilted by means of the screw feed shown in photo at upper right. With this mechanism various angles are arrived at easily and accurately. The wing bolt directly above the scale is used for locking the assembly at the angle of tilt. An extra lock is located at back of table. This photo also gives a good view of the micrometer setting of the ripping fence. The fence is moved to its approximate setting and then final adjustments are made with the micrometer screw. This feature insures great accuracy.

THE Series "900" saw is designed for a general purpose machine. As such it must be able to do fine, accurate work in light or heavy materials. Tests will prove that strips of wood almost as thin as paper can readily be cut on this most unusual machine. Then, it may be called upon to cut its full capacity in metal or tile. Because of this fact, all moving parts which might be damaged by abrasive grit are entirely enclosed.

Geared Self Indexing Miter Gauge

While DRIVER engineers do not claim this to be the only perfect miter gauge yet conceived, they do believe that the craftsman will find in it factors for safety and convenience never before available in any device of this sort. Many types have been developed but none to equal this in practical utility value. The DRIVER gauge is self-indexing, coming automatically to a stop at each fifteen degree position on the scale. The movement of the gauge is accomplished by turning the knurled knob in the same manner as dialing a radio. The possibility of accident due to the operator grasping an ordinary gauge with one hand while making the adjustment with the other is avoided entirely with this new DRIVER gauge. All movement is easily controlled with one hand—it is never necessary to place the hand in the front, for any purpose.

DISC SANDING: By replacing the saw blade with the double-faced sanding disc, the "900" saw becomes an excellent disc sander. The sanding disc is a circular steel plate 8 1/2" in diameter. Cemented to this disc are two aluminous oxide abrasives—one coarse and one fine. The sanding disc may be tilted in the same manner as the saw blade. Thus sanding operations may be done at any angle and either the fine or coarse abrasive used without changing the disc.

GUARD AND SPLITTER: As on all DRIVER saws the guard with splitter is standard equipment. The guard affords maximum protection under all conditions. The splitter, which carries the guard, is an invaluable asset in many classes of work especially in the ripping of green or unseasoned lumber.

MOTOR AND MOTOR MOUNTING: For best results a 3/4 H.P. motor is required. A special motor was designed for this machine. This motor is longer than the average motor but has a smaller diameter so that it may be mounted on the saw base. It is shown and listed on Page 31.

SAW BLADE: Standard equipment is 10" rip saw. Combination and hollow-ground blades at extra cost.

SHIPPING WEIGHTS: B960, 190 lbs.; B961, 215 lbs.

DRIVER RETRACTABLE

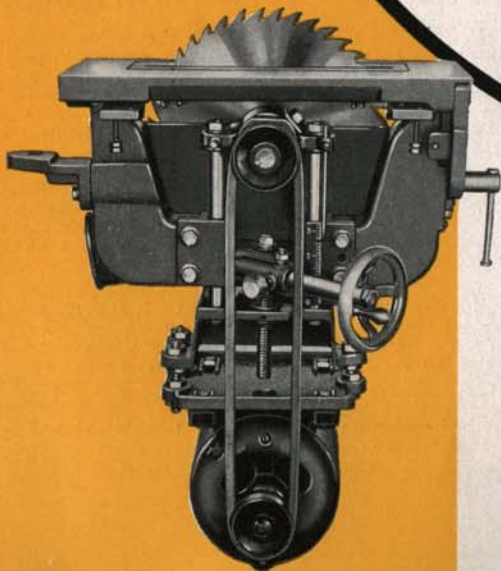
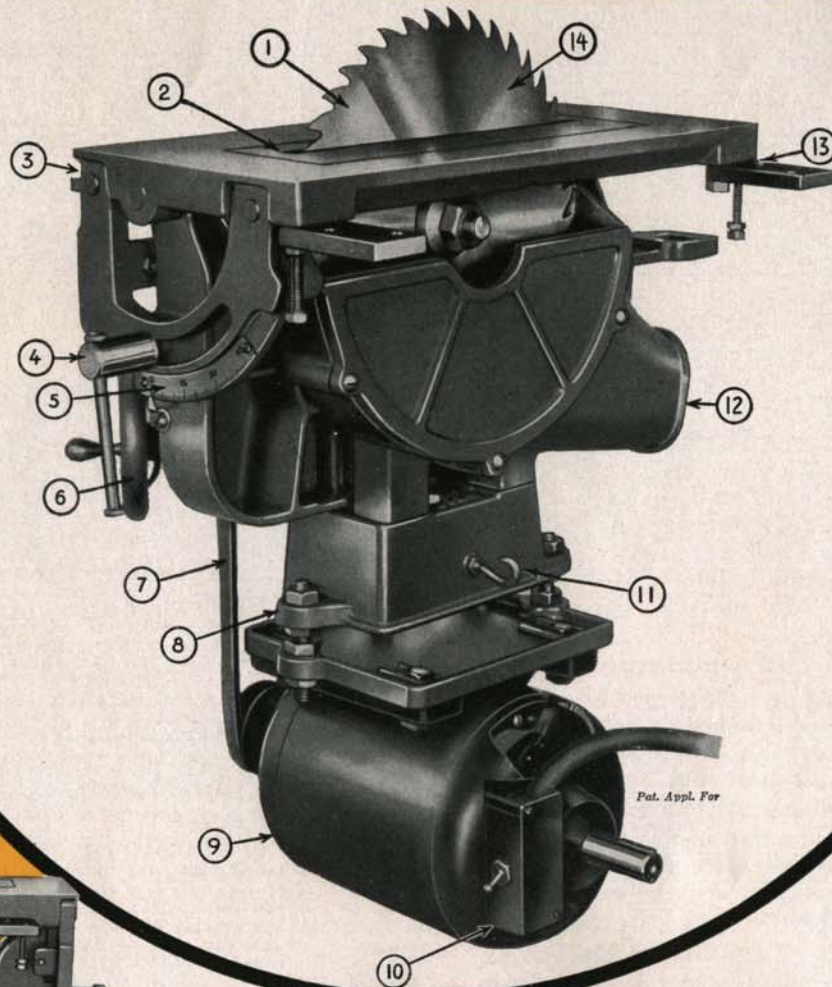

The photo above shows the tilting arbor saw unit installed in a bench. Note the large table area. This feature is of great assistance to the operator and is not available in any bench saw of conventional design.

A new idea in bench saws! This latest DRIVER development is unique in design, in utility and in value. Months were spent in designing, testing and proving it. Now, many of the advantages found only in heavy, stationary saws, are available in this outfit which is readily portable.

With a great many woodworkers a large table is the most desirable feature of a bench saw. Were the table an integral part of the machine and made of iron its weight and cost would both be excessive. This unit may be installed in any bench or table, the amount of working space around the blade depending only on the size of the bench top.

Another important point is the fact that with this unit the work is always flat. When angles are to be cut the whole unit is tilted, permitting every ounce of power to be utilized. There is no twisting of the belt. No countershafts or idlers are required. A counter-weight with cable attached to the unit base assists in tilting.

By simply detaching the splitter and lowering the saw blade, the table top is cleared for assembling projects, painting or other work. The lowering device enables the operator to vary the depth of cut *with extreme accuracy.*

Specifications

1. Cuts full 3" stock.
2. Removable insert for dadoing.
3. Saw unit hinges on top plate.
4. Slide bar bolt locks unit at any angle.
5. Indicator and gauge show position of tilting arbor.
6. Saw blade and motor raised or lowered as a unit by hand-wheel.
7. Heavy duty V belt.
8. Belt adjustment.
9. Three-quarter horse power 3450 R.P.M. 110 A.C. 60 cycle motor.
10. Motor switch.
11. Hook for counter-weight.
12. Outlet for sawdust.
13. Table leveling screw.
14. Highest quality ten-inch saw blade. SKF Ball Bearing Equipped. Shipping weight 112 lbs.

TILTING ARBOR SAW

\$35.00 (Including 72 Page Book of Instructions)
less motor and table but including belt and motor pulley

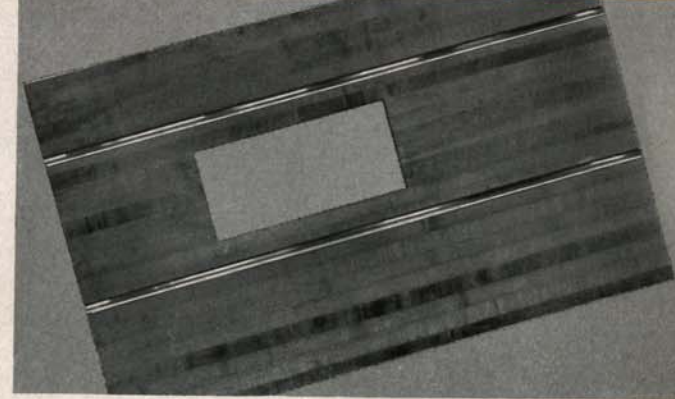
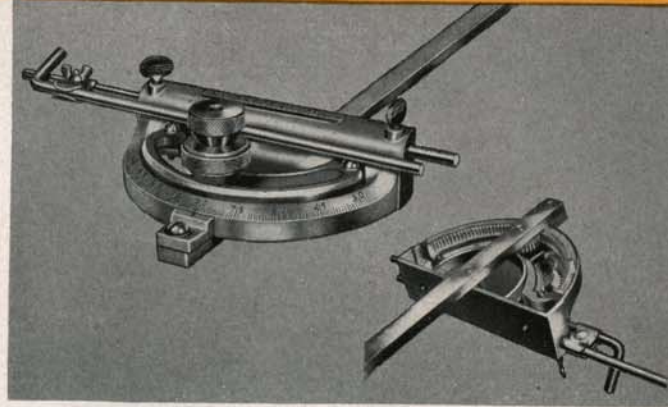

A Startling New Idea

Often, when conducting scientific research with a definite object in view, accidental discoveries are made which entirely overshadow in importance the original object of the search.

So it was in this instance. After DRIVER engineers had developed the new saw arbor unit with worm gear control which is employed on the "700" and "900" bench saws it occurred to them that here was a saw unit, almost complete in itself. That this unit could readily be combined with a few other parts and dropped into place flush with the bench top and provide unlimited table capacity.

Provides Unlimited Table Capacity

The obvious advantages of unlimited table capacity when sawing plus the extra utility afforded by the fact that the saw can be retracted, or lowered, below the table top leaving a clear surface for general bench work—made the idea seem very much worthwhile. After months of experimenting and changes the retractable tilting arbor saw was perfected. As you see it on the opposite page this saw is a thoroughly practical and efficient development—capable of a tremendous volume of work for the cabinet maker or home craftsman. While it has capacity for large, heavy work, yet it does extremely fine work consistently. With this saw, strips of wood barely thicker than paper have been cut without any appreciable variation in thickness when measured with a micrometer.

Geared Self-Indexing Miter Gauge

We believe that the craftsman will find in this new DRIVER miter gauge greater factors of convenience and safety than are available in any other device of this sort. Many types have been developed but none equal to this in practical utility value.

The DRIVER gauge is self-indexing, coming automatically to a stop at each fifteen degree position on the scale. The movement of the gauge is accomplished by turning the knurled knob in the same manner as dialing a radio. The possibility of accident due to the operator grasping the front of an ordinary gauge with one hand while making the adjustment with the other is avoided entirely with the new DRIVER gauge. All movements are easily controlled with one hand—it is never necessary to place the hand on the front of the gauge for any purpose.

Ripping Guide Has Micrometer Adjustment

The ripping guide is faced with laminated maple. Not only does it add rigidity to the guide but protects the saw blade against damage if the guide is accidentally moved too close to the blade. The guide slides on a steel support bar which is calibrated in fractions of an inch. The guide is moved into approximate position and a very fine adjustment obtained with the micrometer screw.

Guard and Splitter

Both are standard equipment. The splitter which carries the guard is an invaluable asset when ripping green or unseasoned lumber.

Laminated Maple Bench Top

A laminated bench top of clear rock maple 48" long by 30" wide by 1 1/4" thick is available. Mounted on the No. 56 legs, it makes an ideal bench for the tilting arbor saw unit. The table has brass miter gauge slots. A rectangular hole of correct dimensions is machined in it, ready to receive the unit.

TALL Bench top (48" x 30" x 1 1/4") \$12.95
56 Set of bench legs (illustrated on page 38) 5.50

Motor Is Mounted Directly on the Frame of Unit

The motor runs in an inverted position bolted directly to the unit base. Belt adjustments are easily made. Motor moves with the unit when it is tilted avoiding twisting of the belt. This direct, unchanging drive is a feature of worthwhile simplicity and efficiency.

Table Is Flat for All Sawing

For work of real accuracy the advantages of a flat table cannot be underestimated. A tilted table requires more careful handling of the stock and even then errors are sometimes unavoidable due to the stock slipping. With the tilting arbor saw much greater accuracy and convenience is assured.

May Be Installed in Any Bench Top

By simply cutting a hole in the top to take the unit any bench may be utilized. By lowering the blade below the bench top a clear surface for painting, assembly of projects, gluing or other bench operations is afforded.

DRIVER P915 JOINTER \$28.95 as shown

Including 72 Page
Book of Instruction

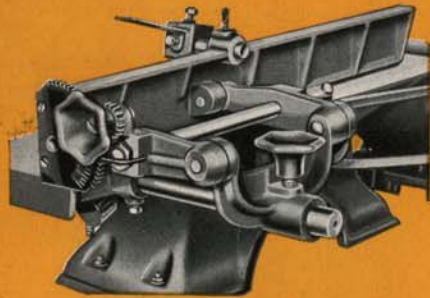

Unique Tilting Fence

Above is shown the ingenious tilting fence. It tilts a full 45° to the right or left, the motion being controlled by a spur gear acting on a geared segment which is part of the fence itself. A scale and pointer indicate clearly the degree of tilt in either direction. The fence may be locked in any position and moved across the table without altering the angle.

The fence is 24" long and 3¼" high, made of well-ribbed cast iron, carefully ground and polished. The hole near the top center is for attaching spring hold-down.

This jointer should not be confused with ordinary 4" jointers. It is longer, heavier, more accurate and without any question more durable. These features . . . combined with many new devices to increase convenience in operation . . . make this machine the finest in its class.

In making certain that defects common in many jointers should not be part of the DRIVER, our engineers carefully designed each sectional casting so as to eliminate strains due to unequal contraction in casting. Where necessary to prevent warping, castings are heat treated or annealed.

In considering the requirements necessary to produce a jointer that would be outstanding from the point of view of the man who demands the best, we did not rely entirely on our own judgment but consulted men whom we consider finished craftsmen with long experience in the use of power woodworking equipment.

A jointer of simple design resulted—sturdy, accurate and correct in its every proportion. We believe that from the standpoint of convenience of operation, utility or general dependability the "900" Jointer has no equal in its field.

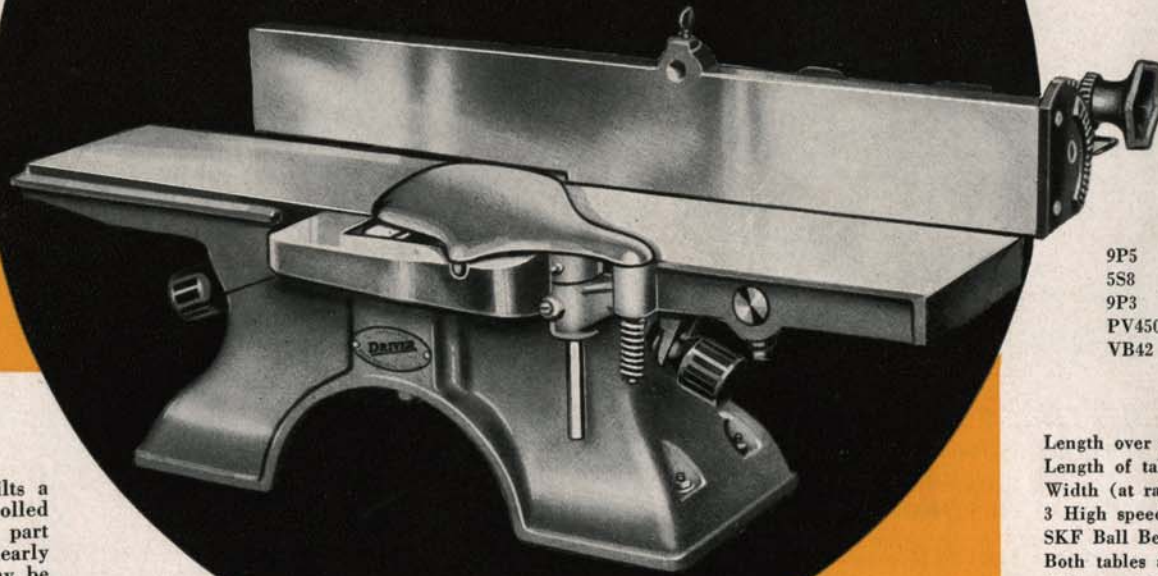

Accessories

9P5	Floating Motor Base.....	\$1.50
5S8	Set of Spring hold-downs.	1.50
9P3	Set of 3 High Speed Knives	2.20
PV450	4" V Pulley.....	.40
VB42	42" V Belt (Heavy Type).	.75

Features

- Length over all 28".
- Length of tables (rear 12¾", front 13¾").
- Width (at rabbeting ledge) 9".
- 3 High speed steel knives.
- SKF Ball Bearings.
- Both tables adjustable.
- Tables cast iron carefully ground.
- Fence 24" long, very rigid.
- Geared tilting device on fence.
- Guard folds down out of way for rabbeting.
- Head turned from solid bar steel.
- Spring hold down available.
- Shipping weight 95 lbs.

TABLES: Close-grained gray iron accurately ground and polished.

CUTTER HEAD: 4¼" long, safety type, machined from solid bar steel, integral with shaft. Dynamically balanced. Designed for speed of 5000 R.P.M. Knives are high speed tungsten steel, carefully honed and adjusted.

BEARINGS: A jointer is only as good as the bearings used, for this reason we have selected what are known the world over as the best—SKF. They are sealed in dust-tight metal housings and require renewal of grease only at rare intervals.

BASE: One-piece construction, with ways and bearing supports carefully machined. On the DRIVER Jointer the conventional spring tensioners used to hold the tables to base are eliminated in favor of positive grip nuts.

GUARD: It is never necessary to remove the DRIVER guard. In rabbeting or adjusting knives the guard is folded out of the way under the overhanging arm of front table.

SPRING HOLD-DOWNS: In planing small strips these hold-downs are almost a necessity. They hold the work firmly against the knives and fence. One is located on the fence, the other on the table.



While rabbeting, or adjusting the knives, the safety guard is simply slipped under the overhanging arm.



The cutter head is tested for alignment with the tables by a delicate gauge which shows variations in thousandths of an inch.

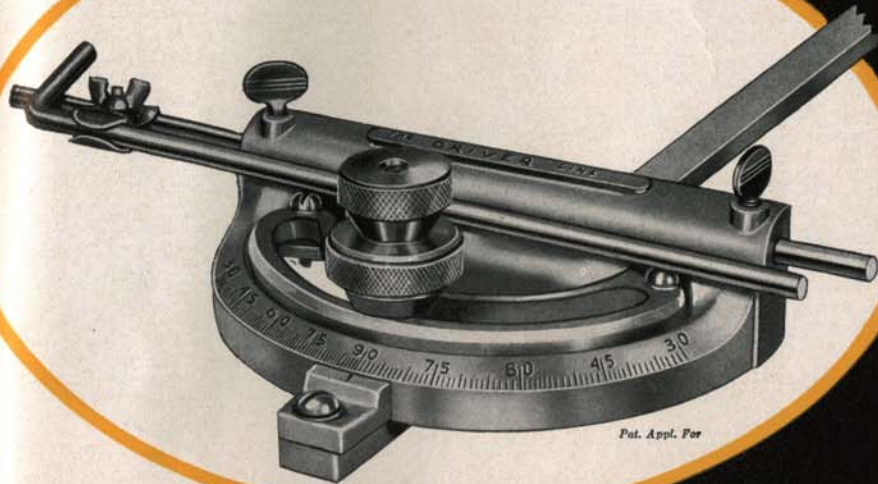

NEW SELF-INDEXING MITER GAUGE

This is an entirely new DRIVER development which enables the bench saw operator to get greater utility from his machine, with a wide margin of convenience and safety. While we do not claim to have conceived and designed the only perfect miter gauge we do believe that the craftsman will find in it more worthwhile features than in any other device of its kind.

The DRIVER gauge is self-indexing, coming automatically to a stop at each fifteen-degree position on the scale. Movement of the gauge head is accomplished by turning the knurled knob in the same manner as dialing a radio. The adjustment of the DRIVER gauge is by means of a rack and gear, actuated by the knurled knob. It is never necessary to put the hand on the front of the gauge to adjust it. Only one hand is required to do the adjusting.

- MG70 Self-Indexing Miter Gauge (for "700" Saw).....\$2.50
- MG90 Self-Indexing Miter Gauge (for "900" Saw)..... 3.00
- MG95 Self-Indexing Miter Gauge (for Tilting Arbor Saw)..... 3.00



B510 BENCH SAW

This rugged bench saw fills the need for an accurate, but inexpensive machine for cross cutting, ripping, and general bench work. The table does not tilt so that if properly adjusted when set up, the operator is insured of a perfect 90° cut at all times. Its accuracy, speed and simplified design combine to make it a splendid tool to use, and should make a valuable addition to any shop.

- B510 Bench Saw (as shown)..... \$9.35

Features

Table close grained gray iron carefully ground, 14" x 10".

Ripping fence solid steel 16" long, 1½" high and 5/8" wide, adjustable at one end. Bearings oilless bronze.

Removable wood insert in table.

Table raises and lowers to vary depth of cut.

Spindle ½" diameter. Takes 7" saw blades.

Capacity with 7" saw 2¼" cut.

Light metal guard and splitter.

Sawdust chute at rear carries dust away from operator.

Recommended operating speed 3000 to 3500 R.P.M.

Motor recommended, 1/3 H.P., 1750 R.P.M.

Shipping weight, 34 lbs. (Accessories for B575 fit the B510.)

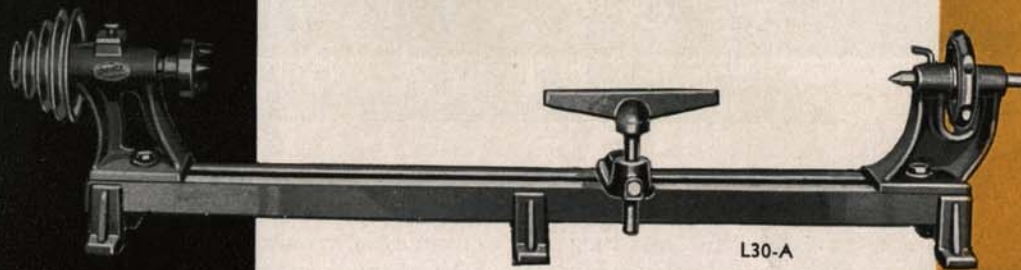

L30-A



L343



L30-A WOODWORKING LATHE

The popularity of this lathe is clearly indicated by the fact that over one hundred thousand have been sold. Only recently the owner of one of these lathes won nearly \$500.00 in prizes with turnings made entirely on his L30-A lathe.

Bronze head bearings, rigid channel iron base, 5/8" head spindle, ball thrust bearing in oil bath, 4-speeds, sturdy cast iron head and tail stocks are features. Bed is 30" long and may be extended by adding another section. 24" between centers, 6" swing.

A full line of accessories consisting of face plates, cup center, adapter for holding sanding drum or disc, grinding, wire or cloth buffing wheels, chisels and spur center are available.

L30-A Lathe (as shown).....	\$4.50
Accessories	
L343 30" Lathe Bed.....	\$1.10
TR112 Bed bracket for tool rest.....	.55
L370 Woodturning dog.....	.85
L359-A Cup center for small turnings..	.30
L345 Face Plate (6" diameter).....	.55
L390 Face Plate (6" cast iron).....	1.10
L346 Skew Chisel.....	.55



L347 Gouge Chisel.....	\$.55
L362 Parting Tool.....	.55
L363 1" Gouge Chisel.....	.55
L375 1" Gouge Chisel (Heavy Duty)	1.10
L376 ½" Skew Chisel (Heavy Duty)	1.10
L377 ½" Spear Point (Heavy Duty)	1.10
L353 ½" Ball Thrust Bearing	.30
L380 Adapter for sanding drum, etc.....	.30
DP110 Drill Chuck (½" capacity)85

DRIVER HIGH SPEED FLEXIBLE SHAFT



HS33
High-Speed Flexible Shaft outfit complete with motor, \$21.65



PR100
\$59.50
Complete as shown with 110 volt A.C. 60 cycle motor

The high speed flexible shaft is intended for wood carving, routing, die grinding and similar operations where small cutting or abrasive tools are used and where high speed is essential. It is a high speed tool in every sense of the word and operates satisfactorily at speeds ranging from 5000 to 10,000 R.P.M. This shaft should not be used at a slow speed or for heavy work.

The surprisingly low price of this high speed shaft should not be considered an indication of inferior quality. We realize that to popularize the ancient art of wood carving and provide a means of doing it with power, the equipment must be priced as low as possible.

The high speed shaft operates from the head stock of the portable outfit. With a 6 1/2" motor pulley and a 1 1/4" pulley on the head stock, 7000 R.P.M. is attained. Because this shaft is designed only for operation as illustrated, no motor coupling is available for attaching direct to motor shaft.

HEAVY DUTY FLEXIBLE SHAFT

Many mechanics, woodworkers, and craftsmen will find the DRIVER PR100 Heavy Duty Flexible Shaft ideal because it requires only a minimum amount of floor space. Being mounted on a portable base it can be rolled from job to job, indoors or out, quickly and easily. Innumerable jobs can be performed by the addition of a few accessories—sanding, grinding, drilling in difficult places, roughing tires, cleaning and buffing welded surfaces and many other tasks can be done with equal ease. The PR100 Flexible Shaft is a solidly constructed machine built to withstand long, hard use. It is equipped with 5 Timken Roller Bearings and has features not obtainable in other machines in this price class.

Motor and shaft may be raised 15 inches with extension stand.

Height in normal position 42", in raised position 57".

Motor swivels and may be locked in any position.

For detailed information write for illustrated folder on the PR100 Flexible Shaft.

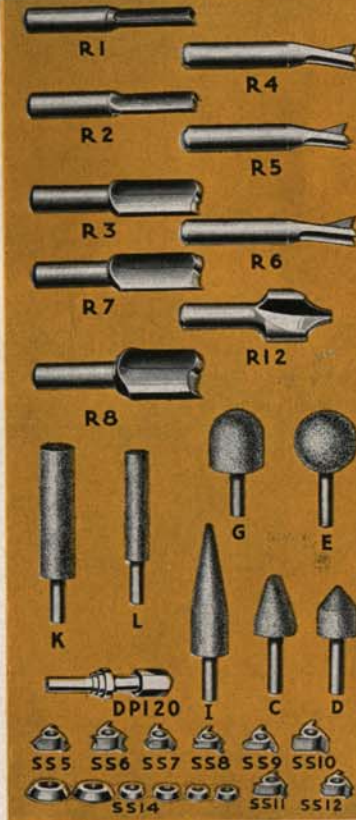

Parts and Accessories

CF1	Casing	\$1.15
CF2	Core	1.15
CF3	Hand Piece	1.15
CF3-A	Collet for 1/4" Shanks30
FS1	Base with Casters	1.10
FS2	Table85
FS4	Support for Jack Shaft85
FS6	Head Stock	1.10
PV125	1 1/4" Pulley for Driving Shaft30
PV65	6 1/2" Pulley for Motor85
VB24	Endless V Belt 24"50
SS5	Fluting Cutter50
SS7, SS9	Cove Cutters, each50
SS10	Straight Face Cutter50
SS6, SS8, SS11	Corner Rounding Cutters, each50
SS12	Surface Bead Cutter50
SS14	Set of Guide Washers and Depth Collars30
DP120	Adapter for Small Cutters30
R1	1/8"-R2, 1/4"-R3, 3/8" Routing Cutters, ea.60
R4	1/4"-R5, 3/8"-R6, 1/2" Dovetail Routers, ea.60
R7	1/2"-R8, 5/8" Routing Cutters, ea.90
R12	3/8"-R10, 1/2" Carving Bits, ea.90
I	Grinding Stone	1.10
K, L, C, G, E, D	Grinding Stones, each85
DS30	3"x1" Sanding Drum85
DS20	2"x1" Sanding Drum65
DS15	1 1/2"x1" Sanding Drum35

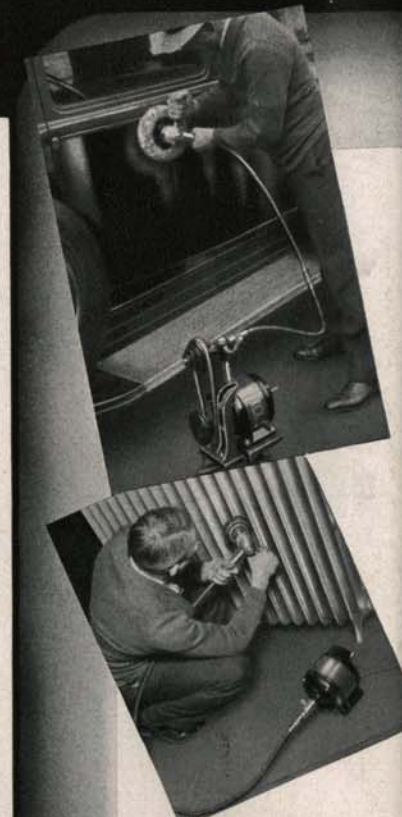

No. 5334
Flexible Shaft Unit for direct motor drive \$5.00

This DRIVER Flexible Shaft unit is for any motor having a 1/2" Shaft. Length over all 49 1/2".

No. A-200
Heavy Duty Flexible Shaft with special coupling \$15.00

Timken Bearing Hand Piece

Designed for heavy work. Core is 3/8" in diameter. Casing is rubber covered.

DRIVER GREEN BAND AND DE LUXE MOTORS



Driver Motors have kept pace with DRIVER Tools in meeting the requirements of craftsmen in both industrial and home workshop fields. As the tools become heavier, sturdier and more efficient motors have been required. Where suitable motors were not available DRIVER engineers have not hesitated to develop the type needed. This year several new types are available.

The wide acceptance of DRIVER Motors and the fact that more and more of them are being sold in fields other than the home workshop, attest the splendid service they have given in the past six or seven years.

Distribution has now reached a point where we have been able to establish authorized service stations in various cities throughout the country. When your DRIVER Motor requires servicing or you have any questions about its operation you can get the name of your local service station from your local DRIVER dealer.



New DeLuxe 1/3 H.P.

This DELUXE Model is not an improved or redesigned motor, but new in every detail. It was designed by one of the foremost engineers in the fractional horsepower field. It is not built to a price—nothing has been skimped. Actual tests prove it to be much more efficient than the average 1/3 H.P. motor. Quiet and cool running, it develops far more than its rated horsepower. The DeLuxe motor is equipped with SKF Ball bearings, double shaft extension, built-in switch and 10 ft. rubber covered cord and plug.

- DL10 1/3 H.P. 1750 R.P.M. 110 Volts, 60 cycle, A.C. DeLuxe Motor\$12.75
 - DL15 1/3 H.P. 1750 R.P.M. 110 Volts, 60 cycle, A.C. Motor with reversing switch 15.75
- (For odd frequencies and cycles add \$1.50)

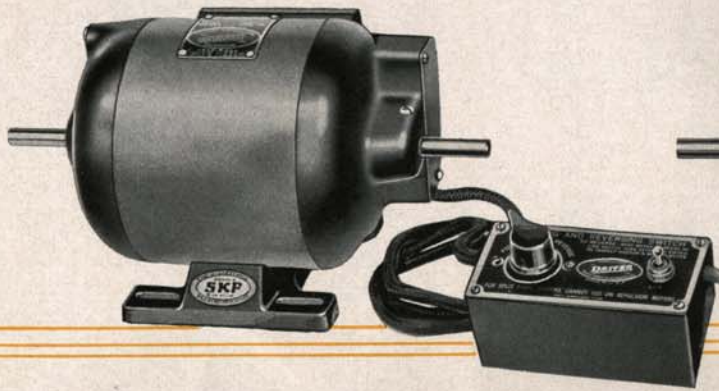

1/2 H.P. Capacitor Motor

A powerful, efficient motor especially adapted to high speed tools such as the spindle shaper, and circular saws up to 8". Its low inrush permits it to be used on practically any house circuit. Its condenser precludes the need of brushes and auxiliary starting winding. Equipped with SKF ball bearings, double end shafts, cord, switch and plug.

- ZT47 1/2 H.P. 3450 R.P.M. 110 volts, 60 cycle, A.C. motor with Reversing Switch\$22.95
- BM50 Same as ZT47 but without Reversing Switch (Has snap switch) 19.95

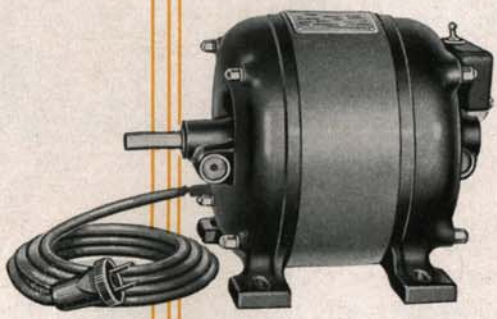

1/4 H.P. 1750 R.P.M. Motor

This motor, equipped with 10 ft. cord, soft rubber plug and snap switch was designed especially for operating the Series 500 Tools and for general utility or light machines. It is quiet in operation and its special construction permits operation in a vertical position providing the shaft extension is up. Bearings high grade phosphur bronze. Oil wicks at bearings distribute oil as required. Will not cause radio interference. The reversing switch may be used on this motor.

- XA43 1/4 H.P. 1750 R.P.M. 110 volts, 60 cycle, A.C. motor\$7.95

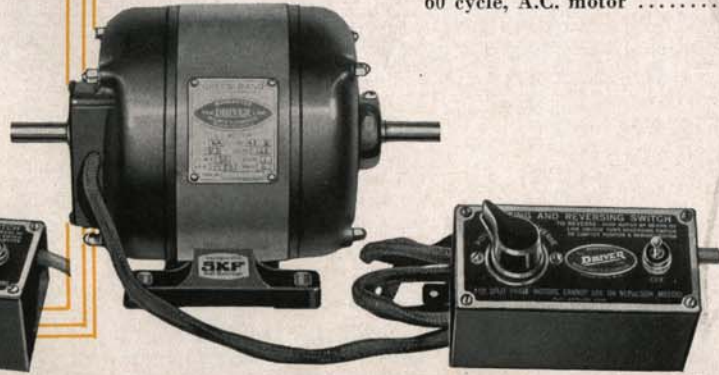

Special Motor for Spindle Shaper

This new motor is intended primarily for high speed routing, shaping and carving. It may be used for slower speed operations providing the proper speed reduction is made. It should not be used where there is a heavy starting load. It is available only with the reversing switch.

- M33 1/3 H.P. 3450 R.P.M. 110 volts, 60 cycle, A.C. motor, with Reversing Switch\$16.95

3/4 H.P. Repulsion-Induction Motor

By redesigning this motor our engineers have succeeded in increasing its power 25% and in making it a cooler, quieter motor. It is especially adapted to operating the "900" Bench Saw and Tilting Arbor Saw. It will develop over 2 H.P. for short periods, yet may be operated on any circuit having a capacity of 12 amperes at 110 volts. By changing the connections in the terminal box of this motor it may be used either on 110 or 220 volt circuits.

- Equipped with SKF ball bearings, double shaft extension, switch and heavy rubber-covered cord and plug.
- M75 3/4 H.P. 3500 R.P.M. 110 volts, 60 cycle, A.C. motor\$28.95

New DeLuxe Heavy Duty Motors

These new DRIVER DeLuxe Motors are heavy-weight Repulsion-Induction type. They are intended for extra heavy work and may be used for driving heavy line shafts, large capacity saws, and other tools where the motor is subjected to unusually heavy, severe service.

Developing their rated horsepower at 1750 R.P.M. instead of 3500 R.P.M. these motors are much larger and heavier than the ZT47 and M33 types. Both the 1/2 H.P. and the 3/4 H.P. motors are well designed, will start a load of several times their rated horsepower, and will pull con-

MOTOR GRINDERS AND MOTOR ACCESSORIES

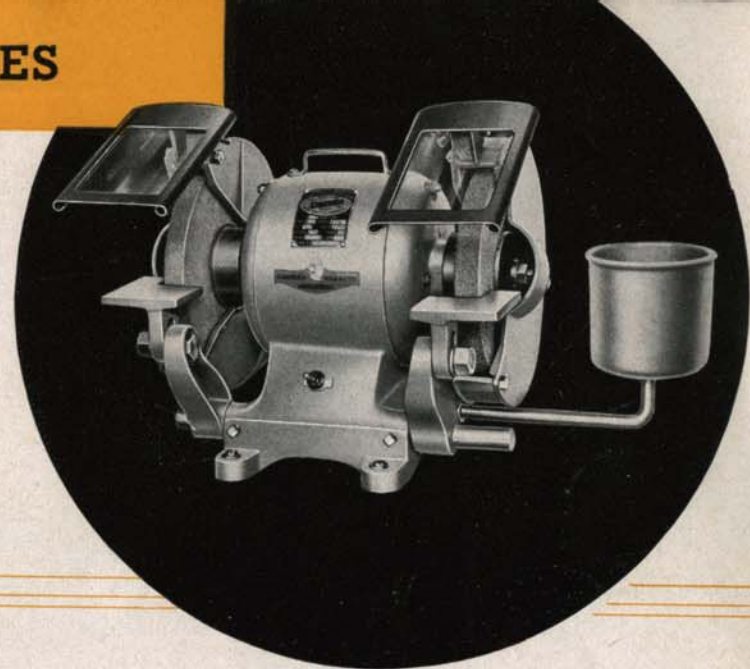
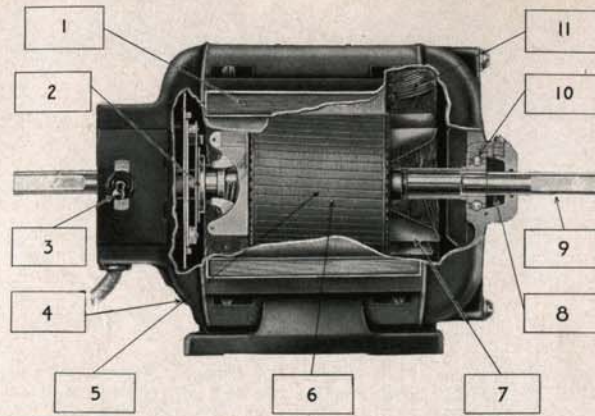
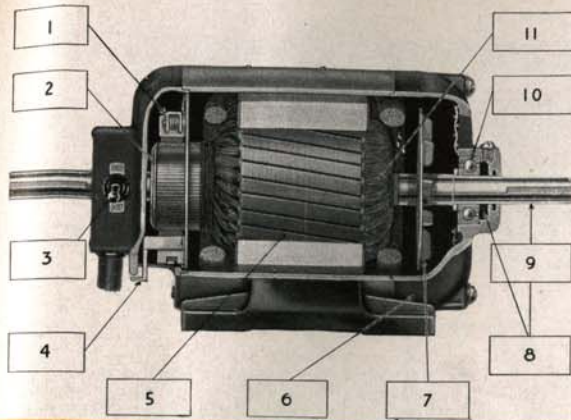

Repulsion Induction Motor

Capacitor Type Split Phase Motor

DRIVER Motor Grinders

1. Brush rigging is simple and rugged. Both brushes are easily accessible and of pig-tail type.
2. Simple, trouble-free centrifugal device short circuits commutator as motor comes to full speed. (Motor then operates on induction principle with no current passing through the brushes.)
3. Convenient "off and on" switch.
4. External lever for reversing rotation of motors.
5. All core laminations are of high grade electric sheet steel.
6. End covers and base are of cast iron to provide utmost rigidity to the motor.
7. Heavy steel rotor blower draws cooling air in through screened end cover openings and forces it through the motor.
8. Large grease reservoir holds lasting supply so that frequent replenishing is unnecessary.
9. Heavy duty shaft machined from high carbon shaft steel. Equipped with keyway at each end.
10. Dust sealed, heavy duty, deep groove ball bearings will give many years of service.
11. Both rotor and stator windings are heavily insulated and thoroughly impregnated with special insulating compound.

1. Iron clad capacitor provides powerful starting torque with low starting current.
2. Positive acting centrifugal cut-out disconnects starting winding after motor is up to speed.
3. Convenient "off and on" switch.
4. Cast iron end covers and base provides great rigidity.
5. Rugged squirrel-cage rotor is practically indestructible.
6. Stator and rotor core laminations of high grade electric sheet steel.
7. Efficient rotor fan blades force cooling air through motor.
8. Large grease reservoir holds lasting supply of grease so that frequent replenishing is unnecessary.
9. Special shaft machined from high carbon shaft steel.
10. Dust sealed, heavy duty, deep groove ball bearings will give many years of service.
11. Heavily insulated windings are thoroughly impregnated with special insulating compound.

In hundreds of shops throughout the country DRIVER Motor Grinders have proved their worth* and won an enviable reputation for maximum efficiency and safety. The present models include several refinements and improvements. On both the 1/4 H.P. and 1/2 H.P. sizes the bearings are fully protected from abrasive dust. Timken roller bearings assure long, dependable performance. The wheels are made of luminous oxide and are carefully balanced. Guards are the latest approved safety type and non-shatterable glass protects the eyes of the operator. Tool rests are heavy material carefully fitted and fully adjustable. The cooling cup, conveniently located, is a worthwhile feature. Not available for 25 cycle or direct current.

tinuous overloads without overheating. They are designed to operate on either 110 volt or 220 volt circuits.



Both motors have SKF ball bearings, built-in switch, heavy cord and plug as regular equipment. Double extension shafts are keyed.

- M5 1/2 H.P. 1750 R.P.M. 110-220 volts, 60 cycles, A.C. Repulsion-Induction Motor (weight 66 lbs.).....\$29.95
- M34 3/4 H.P. 1750 R.P.M. 110-220 volts, 60 cycles, A.C. Repulsion-Induction Motor (weight 75 lbs.)..... 39.95



Pat. No. 1,860,150

Starting and Reversing Switch

This switch can easily be applied to DRIVER motors having a Serial Number over 1,300,000—also to motors Type XA frame 43, 1/4 H.P.; Type XA frame 44, 1/3 H.P.; Type ZT frame 47, 1/2 H.P. or to any standard split phase motor having both ends of the starting and main windings brought out.

RX10 Reversing Switch\$2.95



This floating motor base affords an ideal drive when motor is mounted upside down as on lathe benches. FL1 Motor Base....\$1.65



With this adjustable spring motor mounting belt adjustments are made by turning the lever. SBI Spring Base.\$1.10

No. G625 1/4 H.P. 3500 R.P.M. (60 cycle, 110 volts) motor, wheels 6" x 3/4", fine and coarse...\$22.50

No. G750 Same as G625 but with 1/2 H.P. 3500 R.P.M. (60 cycle, 110 volts) motor and 7" x 3/4" wheels 27.25



A motor base (floating type) for use with the motor mounted in normal position on top of bench. 9P5 Motor Base.....\$1.50



These rails provide greater movement of motor for belt adjustments. Can be used for any motor. MB1 1 Pair Motor Rails.\$.75

DRIVER FRICTION CLUTCHES AND TRANSMISSION EQUIPMENT

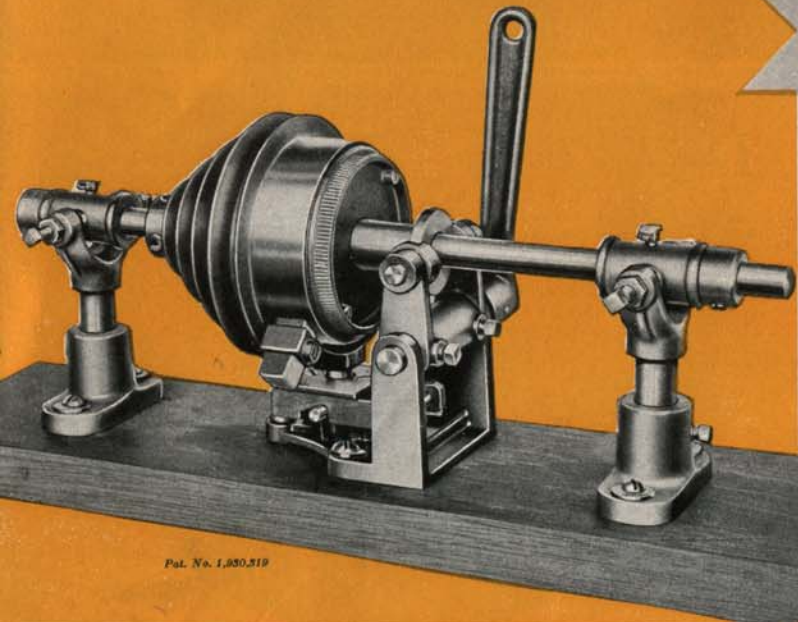

Pat. No. 1,850,519

DRIVER Friction Clutch

There is hardly a user of power tools who has not felt the need of a clutch—some device that would permit him to start and stop a machine quickly without throwing off the belt or stopping the motor. Then, too, many shops are located in homes where the ordinary house fuses burn out when the motor is required to start a machine as well as itself. With a DRIVER Clutch these difficulties are overcome. The motor starts up without any load and, after it has come up to speed the load is applied simply by engaging the clutch.

This new DRIVER Clutch is an improvement over the previous models. A positive-acting brake has been added. Immediately the clutch disengages the brake engages thereby providing positive stops and starts. The advantage is at once apparent especially when operating a jig saw or similar machine where a line is being followed. By arranging a foot control utmost convenience is attained.

The DRIVER Clutch is a model of simplicity. It has no flimsy parts to get out of adjustment or alignment. The friction elements comprise a double-faced core of moulded brake lining material and a cast iron recess to receive it.

- C41 Clutch with brake (to fit 1/2" shafts) . . . \$ 8.50
- C40 Clutch without brake (to fit 1/2" shaft) . . . 5.00
- C56 Clutch with brake (to fit 3/4" shaft) . . . 10.50
- C55 Clutch without brake (to fit 3/4" shaft) . . . 7.00



L361



FX20



SA7



L358



L350A



L351X

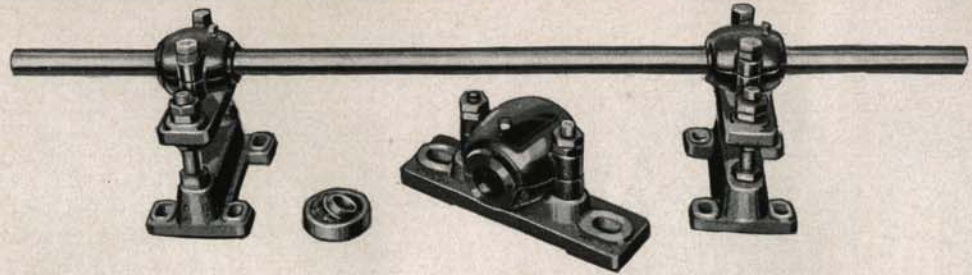

SKF Self-Aligning Ball Bearing Hanger

DRIVER Hangers with S.K.F. Self-aligning Ball Bearings are the finest available. They are far superior to babbit, sleeve or plain bearings. Binding due to faulty alignment is entirely eliminated by the self-aligning feature which permits bearings to function equally well in line or out of line. All kinds of power tools and light machinery are driven by this DRIVER

Shaft equipment at an absolute minimum of friction loss. The same hangers with bronze self-aligning bearings instead of ball bearings are available. Never before has transmission equipment of such outstanding quality been offered at such a small investment. Now every shop can have the best.

SA23B 3/4" Self-Aligning Ball Bearing Hanger. \$3.75

- L350A Bronze Bushed Bearing (1/2") \$.30
- L361 Bronze Bushed Shaft Hanger (1/2") 1.00
- OB24 3/4" Self Aligning, Bronze Bushed Pillow Block 2.00
- OB25 3/4" Self Aligning Bronze Bushed Hanger 2.95
- OB87 7/8" Bronze Bushed Self-Aligning Pillow Block 2.75
- SA78 7/8" Self-Aligning S.K.F. Ball Bearing Pillow Block 4.00
- SA23 3/4" Self-Aligning S.K.F. Ball Bearing Pillow Block 3.00
- SA23B 3/4" Self-Aligning S.K.F. Ball Bearing Hanger 3.75
- L351 1/2" x 24" Steel Shaft25
- SA1 3/4" x 48" Steel Shaft 1.00
- OB26 Special 3/4" Shaft, 1/2" at ends, 16" long85
- L351X Rigid Type Shaft Coupling (1/2")25
- FX20 Flexible Type Shaft Coupling (1/2")30
- C58 5/8" Shaft Collar15
- L358 1/2" Shaft Collar10
- SA7 3/4" Shaft Collar30
- L353 1/2" Ball Thrust Bearing30
- 58 5/8" Ball Thrust Bearing40
- 75 3/4" Ball Thrust Bearing55
- 1/4" Hollow Set Screw05



DRIVER Jack Shaft

A handy set-up for increasing or reducing speeds. It can be placed between the source of power and any power tool. The holes in the base are placed in the same position as those on the base of the DRIVER motor so that the jack-shaft can be installed on any base that the motor fits. This is of the great advantage in increasing the speed of a drill press for routing or shaping or reducing the speed for mortising and drilling. For increasing the number of speeds of a lathe or other bench machine the jack-shaft may be mounted on the bench.

516 Jack Shaft complete (1/2" shaft) \$2.75



Ball Thrust Bearings

There are many places in the shop where these ball thrust bearings will come in handy. They are designed primarily to absorb the end thrust of shafts and spindles and should not be used to carry a constant radial load.

- L353 1/2" Bore, Ball Thrust Bearing \$.30
- 58 5/8" Bore, Ball Thrust Bearing40
- 75 3/4" Bore, Ball Thrust Bearing55



Hollow Head Set Screws

These set screws of chrome molybdenum steel, milled from the bar may be used, in the two sizes supplied, on all DRIVER pulleys. The wrench exerts tremendous pressure on the screw effectively preventing pulleys from loosening.

- 3/4" Hollow Set Screws \$.05
- 5/16" Hollow Set Screws05
- Wrench for 3/4" Set Screws05
- Wrench for 5/16 Set Screws05



Motor Work Arbor

A handy attachment for holding sanding drum or disc, grinding, cloth buffing or wire scratch wheels and drill chuck. Attaches directly to motor shaft or end of countershaft. Fits all 1/2" Shafts.

No. 2 Work Arbor (with 3 jaw, 1/2" capacity chuck) \$1.00

PULLEYS AND BELTING

Use Driver Belts for Full Efficiency

To realize the utmost from your power tools and for greatest economy use genuine DRIVER Belts, exclusively. They have been thoroughly tested and subjected to every condition under which tools can be operated. DRIVER belts deliver full power with minimum tension. They wear indefinitely and require no attention other than occasional adjustment.

The real test of a belt comes in flexing, or bending, as it passes over a small diameter pulley. This flexing, especially if the belt is operated daily at high speed, will quickly ruin a belt unless proper care has been taken in design and manufacture to offset this action.

DRIVER belts are built exclusively for DRIVER tools. The particular requirements of the various machines have been taken into account. As a result you will find that DRIVER belts invariably outlast others by a wide margin.

The cross-section illustration in the center of the belt group at the right shows how DRIVER belts are built up of cords and rubber. Every known factor that can contribute to dependability and efficiency is incorporated in them.

DRIVER "V" belts have 43° angles.



"Hair-on" "V" Belting

Hair-on "V" Belting is convenient to use when belts of special length are required. It is excellent quality leather. May be coupled together with ordinary belt hooks.

L400 "V" Leather Belting (per Ft.) \$0.25

Round Hair-on Belting

DRIVER "Hair-on" round leather belting has proved itself the finest obtainable. It costs less to use because of its unusually long life. Coupled together with belt hooks.

L356 Round Leather Belting (per Ft.) \$0.10

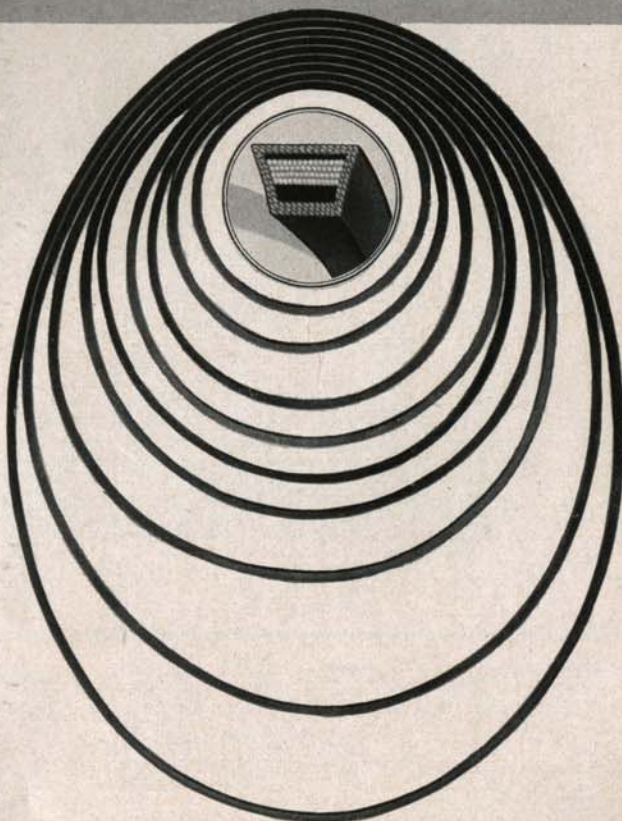

Belt Listing

DRIVER Endless "V" Belts are available in convenient lengths for all shop installations. They are moulded into one endless piece and should be used as endless belts only. Cutting them to various lengths and coupling the ends together with a belt hook is not advisable.

The standard weight DRIVER "V" Belt is 7/16" wide at the top, having an angle of 43°. The heavy section belts are 1/2" wide.

VB20 20".....\$0.50	VB62 62".....\$1.00
VB24 24"..... .50	*VB66 66"..... 1.00
*VB29 29"..... .60	VB86 86"..... 1.25
*VC34 34"..... .60	
*VB39 39"..... .60	NOTE: Belts indicated with * may be secured in Heavy Sections.
*VB42 42"..... .75	
*VB48 48"..... .75	
*VB58 58"..... .85	

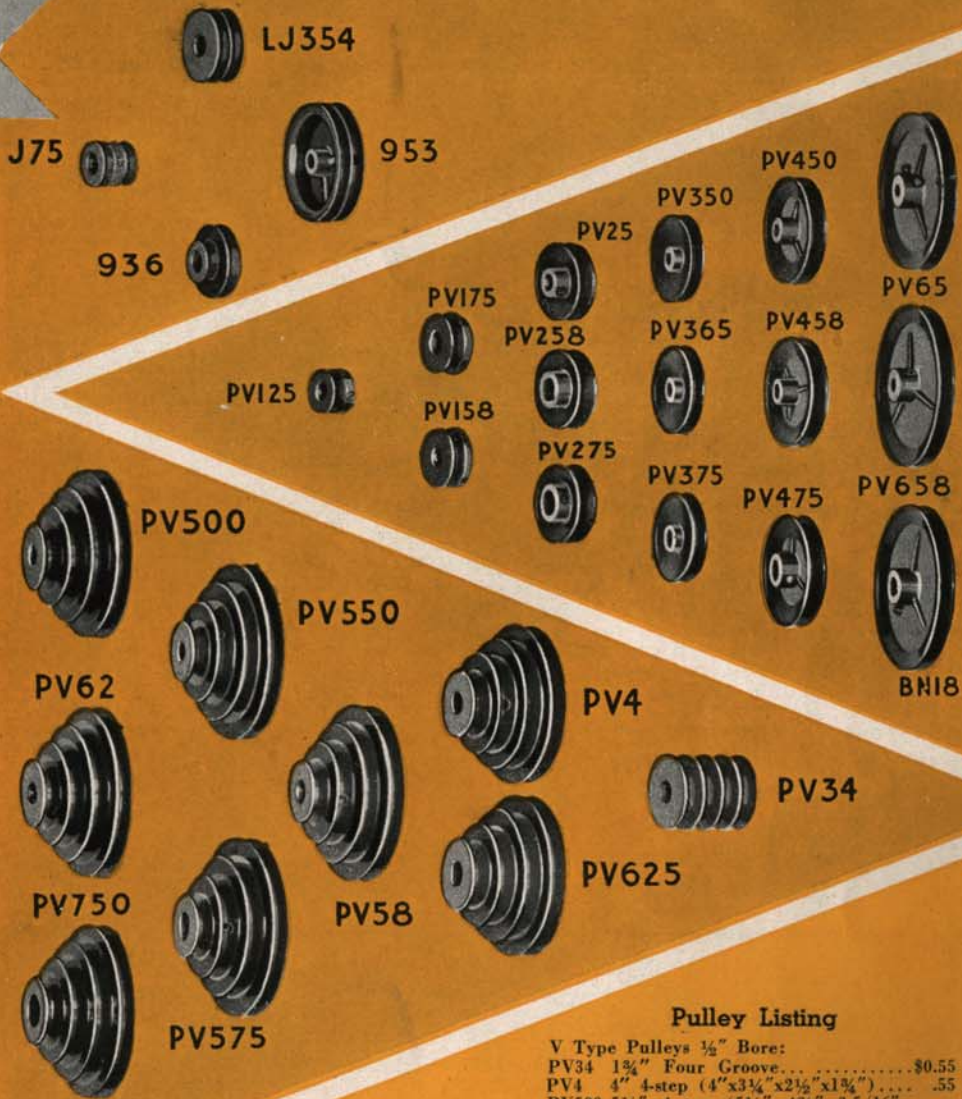

Pulley Listing

V Type Pulleys 1/2" Bore:	
PV34 2 1/2" Four Groove.....	\$0.55
PV4 4" 4-step (4"x3 1/4"x2 1/2"x1 3/4")....	.55
PV500 5 1/2" 4-step (5 1/2"x4 3/8"x3 5/16"x2 3/4").....	1.10
PV550 5" 4-step (5"x3 3/8"x2 13/16"x1 3/4").....	.85
V Type Pulleys 5/8" Bore:	
PV158 1 3/4".....	\$0.30
PV365 3".....	.40
PV458 4".....	.40
PV625 4" 4-step (4"x3 1/4"x2 1/2"x1 3/4")....	.55
PV58 5" 4-step (5"x3 3/8"x2 13/16"x1 3/4").....	.85
5/8" Bore:	
PV62 5 1/2" 4-step (5 1/2"x4 3/8"x3 5/16"x2 3/4").....	1.10
PV658 6 1/2".....	.85
V Type Pulleys 3/4" Bore:	
PV275 2 1/2".....	\$0.30
PV475 4".....	\$0.40
PV375 3".....	.40
BN18 6 1/2".....	.85
PV575 5" 4-step (5"x3 3/8"x2 13/16"x1 3/4").....	.85
PV750 5 1/2" 4-step (5 1/2"x4 3/8"x3 5/16"x2 3/4").....	1.10
(Hollow-head set screws and wrenches in 1/4" and 5/16" diameter listed on previous page.)	

Round Belt Pulleys 1/2" Bore:	
936 1 5/16"x1 3/4" two step.....	\$0.30
LJ354 1 3/4" Double Groove.....	.30
J75 1" Double Groove.....	.30
953 3" Double Groove.....	.40
V Type Pulleys 1/2" Bore:	
PV125 1 1/4".....	\$0.30
PV175 1 3/4".....	\$0.30
PV25 2 1/2".....	.30
PV350 3".....	.40
PV450 4".....	.40
PV65 6 1/2".....	.85



9LB15 Bench complete for "700" and "900" lathes\$17.00
 5LB10 Bench complete for "500" lathes 15.50
 BL1 Bench legs only (for lathe) "500," "700" or "900" 11.00

Benches

These DRIVER Benches are the finest obtainable for power tools. Legs are cast iron, adjustable to various heights. Tops are selected clear maple 1 3/4" thick.

The 9LB15 Bench is 57" long by 11 1/2" wide. All holes are drilled and bolts furnished.

The 5LB10 Bench is 37" long by 11 1/2" wide. While this bench was designed primarily for the 500 lathes it makes an equally good bench for the J724 Jig Saw and other machines. Legs for either are available separately.

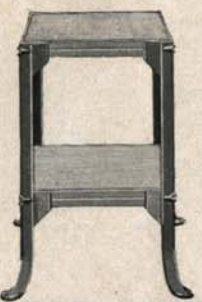

Machine Stand

Has 5-ply wood top and shelf which deadens machine noise. Rigid pressed steel legs make table exceptionally firm. Ideal for band saws and drill presses. Height 30 1/2", size of top 16 1/2" x 15", weight 23 lbs. Complete with all fittings.
 T1 Stand complete. \$6.00

Bench Legs

Here's a set of strong steel legs that will enable you quickly to set up a work bench. Put a 2" wood top on and it will be entirely satisfactory. Legs are 3 1/4" high and 21" wide at the top.

56 Workbench legs (as shown).....\$5.50



A



B

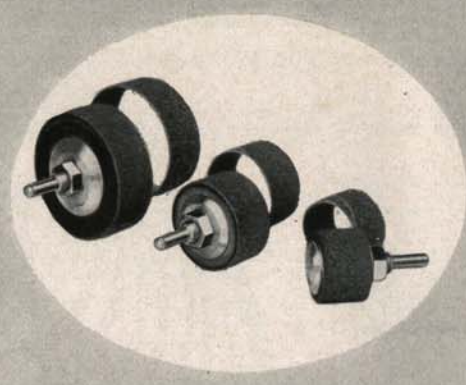

C

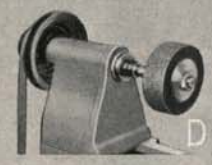

D

Three New Driver Sanding Drums

Sanding, always a tedious operation by hand, is done easily and quickly with these sanding drums. They are made of moulded rubber. The abrasive belts are held on by expansion of the rubber effected by tightening the spindle nut.

- A. Shows a typical drill press installation.
 - B. Used as a portable sander with flexible shaft.
 - C. Permanent set-up on the polishing head.
 - D. Easily attached to the lathe.
- | | | |
|------------------------------------|--------|--|
| DS30 3" x 1" Sanding Drum..... | \$0.85 | DS30C Coarse Abrasive Sleeve (for DS30) 1/2 doz. .60 |
| DS20 2" x 1" Sanding Drum..... | .65 | DS30F Fine Abrasive Sleeve (for DS30) 1/2 doz... .60 |
| DS15 1 1/2" x 1" Sanding Drum..... | .35 | DS20C Coarse Abrasive Sleeve (for DS20) 1/2 doz. .45 |
| | | DS20F Fine Abrasive Sleeve (for DS20) 1/2 doz... .45 |
| | | DS15C Coarse Abrasive Sleeve (for DS15) 1/2 doz. .45 |
| | | DS15F Fine Abrasive Sleeve (for DS15) 1/2 doz... .45 |

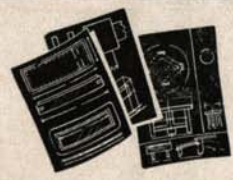

Blueprint Service

Large 30" x 20" blueprints of things to make, furniture, toys, lawn ornaments etc., authentic in design and accurate in detail are available in wide variety for \$0.25 each. Ask your dealer for a complete list or send your request direct to us.



Free Inlay Folder

All of the popular designs of inlays and banding are shown in actual colors in this folder. They add the professional touch to furniture. Inlaying is easily done. Full instructions furnished. New low prices.



EL5 Flexo Lamp. As shown, less bulb \$1.50.

Driver Flexo Lamp

The convenience of this lamp, which has a flexible neck and may be bent to any angle, will be apparent to every man who has a shop. It can be installed on the band saws, jig saws, drill presses and other machines by drilling and tapping a single hole in a convenient location. The contribution this lamp makes to accuracy and safety recommends its use on every possible machine. Finished in beautiful cadmium plate. Cap screws for attaching included.



Instruction Books

New, practical information on machine operation. Easy to understand, fully illustrated. 72 pages of valuable data in each book. First ones of their type available.

- BK1 The Bench Saw, Jointer and Shaper\$.50
- BK2 The Drill Press... .50
- BK3 The Lathe..... .50
- BK4 The Band Saw and Jig Saw50
- BK10 Set of 4 books as above 1.50



Quick-Setting Cement

This cement is prepared especially for attaching sanding discs to metal face plates, sponge rubber backing or wood blocks. It sets almost instantly, enabling the operator to replace discs as often as necessary with little delay. The advantages of this feature are apparent when sanding large areas with the flexible shaft.

The slight flexibility of this cement makes it an ideal adhesive for many jobs where some flexing or "give" is essential.

- FS418 1/2 pt. can.....\$.39



A CRAFTSMAN'S GLUE MADE FOR THE WORKSHOP

Gill - - - .30
Half Pint - - - .50



LePage's Liquid Glue can be purchased in convenient sizes at hardware, paint and department stores from coast to coast. Its unquestionable superiority as a workshop "tool," combined with its general usefulness about the home, makes it doubly valuable—for LePage's not only holds wood perfectly, but can be used

with equal success in gluing paper, cloth, leather, felt and for general repair work. Keep a can of LePage's glue handy in your workshop at all times: for years it has proven to both amateur and professional craftsmen that it's an investment worth many times its slight cost as an aid to building stronger and better workshop projects.

RUSSIA CEMENT CO.
Gloucester, Mass.

WHEN you're building a shop project, it's annoying to have to interrupt your work to mix or heat glue before applying it to the job. By using LePage's, you eliminate this unnecessary delay because you have at your finger-tips the finest glue available, mixed in correct proportions and ready to use the exact moment you need it. LePage's glue is a workshop thorough-bred, recognized by skilled craftsmen, cabinet makers and furniture manufacturers as the product of generations of master glue-makers skilled in the art of making really fine glues.

Like the professional, the home workshop enthusiast will find that LePage's is a valuable assistant in making strong projects. When a home made article breaks or collapses it's because the weakest joint has given way. By using LePage's glue on every joint even if nails, screws or bolts are used, you reduce the hazard of weak joints and have the assurance of stronger and sturdier articles.

The small amount of LePage's necessary to glue the most difficult job, plus the fact that it maintains its adhesive qualities indefinitely makes LePage's extremely economical to use, and it will quickly repay its small cost many times. Get LePage's glue from your tool dealer today, and try it on the next workshop project you make.

Holds Veneer Perfectly

Veneering table tops, dressers, chests and other projects requires an unusually strong binding adhesive that will hold the veneer panels permanently so that they will not curl from the original wood nor spread from the edges that have been butted together. LePage's glue will grip and hold veneer panels more permanently than any other glue. In a recent test, two pieces of rock maple were glued side to side with LePage's, and subjected to a strain to find the giving point. At a pressure of 10,955 lbs. the wood itself broke and the glued surfaces remained intact! Certainly a glue that holds under such conditions will hold veneering perfectly under the most severe treatment.

Ideal For Inlaying

The artistic beauty and distinction added to articles inlaid with designs and borders is well worth the time and effort spent. What a disappointment it is however, to find that after a month's use the tiny bits of wood pull up and are lost or broken, or that the delicate shades of rare wood have been destroyed by the use of inferior glue. It's better to use LePage's and know your job is being done correctly than to take chances on substitutes that may ruin your painstaking work. LePage's glue holds inlay designs in position permanently and will not discolor even the most delicate shades of wood used in the finest types of inlay work.

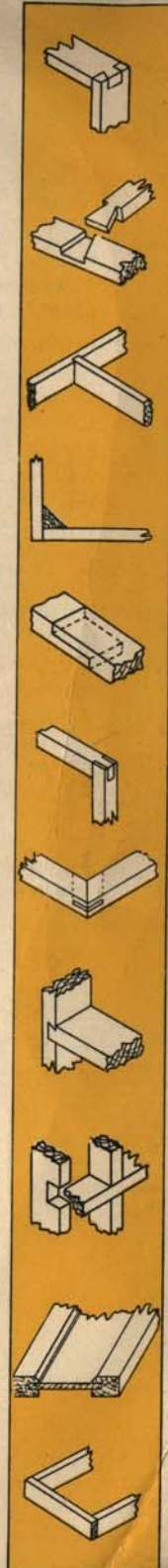

A BACKGROUND OF EXPERIENCE

Many who look through this catalog will recall the first DRIVER TOOLS which were announced some seven years ago. While the first tools did not have the same features or conveniences as the new 1935 models yet they did have one *outstanding virtue*. They did provide *more tool value per dollar spent* than was available elsewhere.

In the years that have passed DRIVER has worked unceasingly to build the type of tools best fitted to the craftsman's needs. To continue to give *more tool value per dollar spent* than could be obtained elsewhere. Thousands of dollars are spent annually in research and development. When heavier tools were needed DRIVER built them. But not for a minute has DRIVER overlooked the man who prefers to make his start with lighter tools. Today three different lines in three price classes—all built to one standard of quality—are available. That DRIVER ideas and methods are universally accepted by the craftsman is evidenced by the fact that *more DRIVER-BUILT tools are being built and sold today than any other make*. Only a pioneer—intimately experienced in craftsmen's problems—can achieve a record like this.

All the resources of a modern plant containing over 125,000 sq. ft. of floor space are devoted exclusively to the development of DRIVER POWER TOOLS.

WALKER-TURNER CO., Inc.
Plainfield, N. J., U. S. A.

All prices F. O. B. Plainfield, N. J. Subject to increases up to 5% at distant points, for transportation. Prices subject to change without notice.

