

**5110 WALKER-TURNER FOUR SPEED 12" WOOD LATHE**

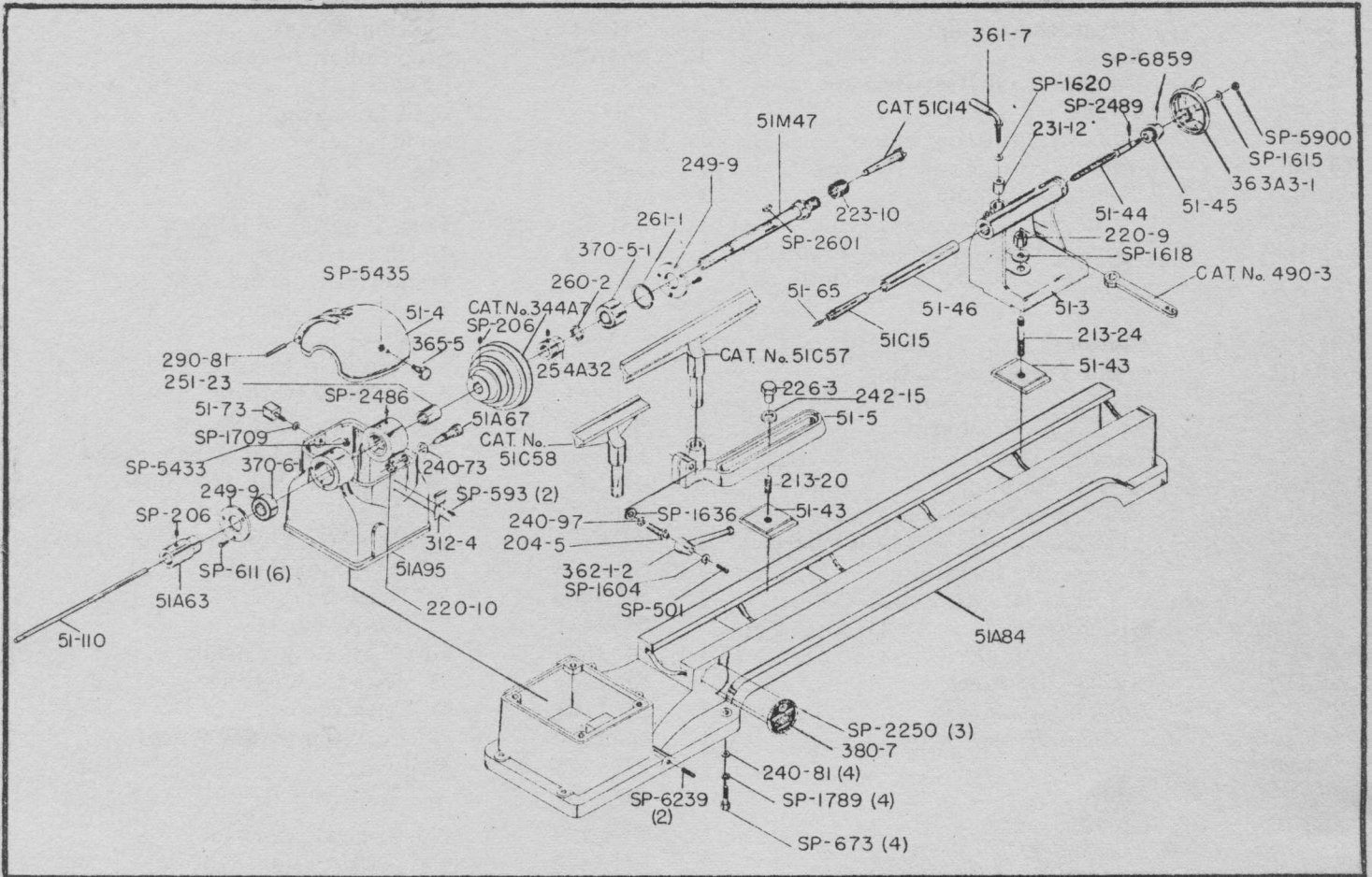

Fig. 1.

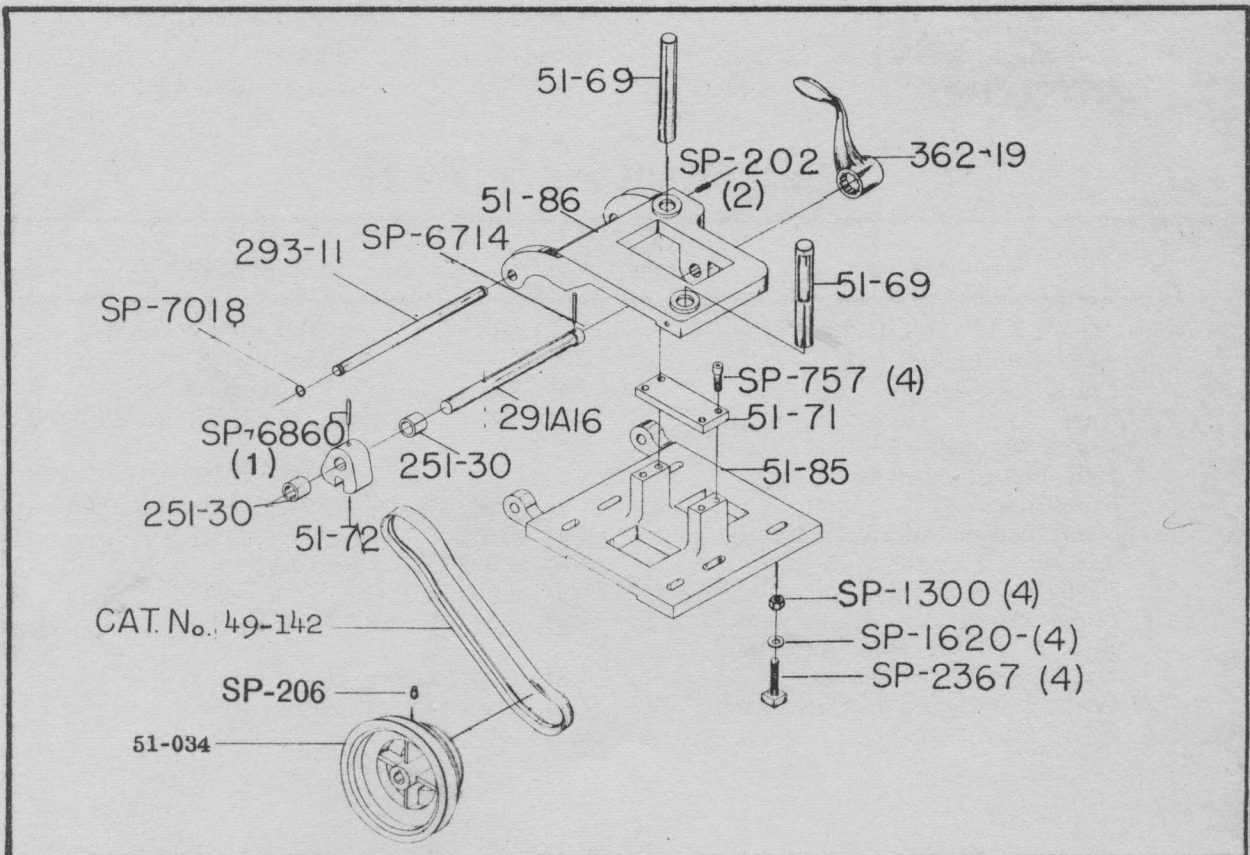

Fig. 2.

## Replacement Parts (Fig.1)

Part No.	Description	Number Required	Part No.	Description	Number Required
51-3	Tailstock Casting	1	251-23	Bearing Spacer	1
51-4	Cover	1	254A32	Stop Collar, Including:	1
51-5	Bottom Tool Rest Bracket	1		SP-205 5/16"-18 x 1/4" Set Screw	2
51-43	Clamp	2	260-2	Split Lock Ring	1
51-44	Spindle Adjusting Screw	1	261-1	Split Ring	1
51-45	Spindle Adj. Screw Bearing	1	290-81	Pin	1
51-46	Tailstock Spindle	1	312-4	Latch Spring	1
51M47	Lathe Spindle	1	361-7	Lock Plug Hand Screw	1
51A63	Driving Pulley Stop, Including:	1	362-1-2	Locking Handle	1
	SP-206 5/16"-18 x 5/16" Soc. Set Screw	2	363A3-1	Handwheel, Including:	1
				364-1 Handle	1
51-65	Center	1	365-5	Knob	1
51A67	Index Finger, Including:	1	370-5-1	Double Row Bearing SKF 703722	1
	220-10 Jam Nut	1	370-6-1	Single Row Bearing	1
	240-73 Washer	1	SP-206	5/16"-18 x 5/16" Set Screw	3
51-73	Hinge Block	1	SP-501	1/4-20 x 1" Rd. Hd. Mach. Screw	1
51A84	Bed, Including:	1	SP-593	#10-24 x 3/8" Rd. Hd. Screw	2
	380-7 Name Plate	1	SP-611	1/4"-20 x 1/2" Hex. Hd. Cap Screw	6
	SP-2250 #4 x 3/16" Drive Screw	3	SP-673	3/8"-24 x 1 1/4" Hex. Hd. Cap Screw	4
51A95	Headstock, Including:	1	SP-1615	3/8" SAE Flat Washer	1
	252-16 Bearing Stop Collar	1	SP-1604	1/4" Washer	1
	SP-5030 3/16" x 3/4" Groove Pin, Type #1	1	SP-1618	1/2" Std. Washer	1
51-110	Knock-out Rod	1	SP-1620	5/16" SAE Flat Washer	5
204-5	Locking Stud	1	SP-1636	1/2" SAE Flat Washer	1
213-20	Locking Screw Stud	1	SP-1709	3/8" Lockwasher	1
213-24	Stud	1	SP-1789	3/8" Int. Shakeproof Washer	4
220-9	Nut	1	SP-2486	Ball Oiler	2
223-10	Spindle Nut	1	SP-2601	#9 Woodruff Key	1
226-3	Locking Nut	1	SP-5433	3/8"-16 Hex. Jam Nut	1
231-12	Spindle Locking Plug	1	SP-5435	5/16"-18 Hex. Jam Nut	1
240-81	Flat Washer	4	SP-5900	3/8"-16 Hex. Nut	1
240-97	Flat Washer	1	SP-6239	3/8"-16 x 1" Set Screw	2
242-15	Flat Mach. Washer	1	SP-6714	Roll Pin	1
249-9	Bearing Flange	2	SP-6859	5/32" x 1/2" Groove Pin	1
			344A7	Pulley	1
			490-3	Wrench	1

## Replacement Parts (Fig.2)

Part No.	Description	Number Required	Part No.	Description	Number Required
<b>MOTOR PLATE ASSEMBLY</b>			SP-1620	5/16 SAE Flat Washer	4
51-69	Motor Plate Adj. Pin	2	SP-2367	5/16-18 x 1 1/2" Sq. Hd. Bolt	4
51-71	Plate, Cam Brng.	1	SP-6860	5/32 x 1" Groove Pin	1
51-72	Cam	1	SP-7018	Snap Ring, Waldes #51-50	2
51-85	Motor Mounting Plate	1		<b>ACCESSORIES</b>	
51-86	Belt Tightener Brkt.	1	Cat. # 46-551	Tool Rest Bracket Assembly	1
251-30	Cam Spacer	2	Cat. # 933	Spur Center	1
291A16	Shaft, Motor Mount, Including:	1	Cat. # 934	Cup Center	1
	362-19 Handle	1	Cat. # 692	12" Tool Rest	1
	SP-6714 Roll Pin	1	Cat. # 51-125	6" Tool Rest	1
293-11	Hinge Pin	1			
SP-202	1/4-20 x 1/2" Hex. Soc. Set Screw	2	Cat. # 51-034	Pulley	1
SP-206	5/16"-18 x 5/16" Set Screw	1	Cat. # 49-142	V-Belt	1
SP-757	5/16-18 x 3/4" Soc. Hd. Cap Screw	4			
SP-1300	5/16-18 Hex. Nut	4			