

12" VARIABLE SPEED LATHES

• • WOODWORKING • • POLISHING • •

PRODUCT DATA SHEET No. 22

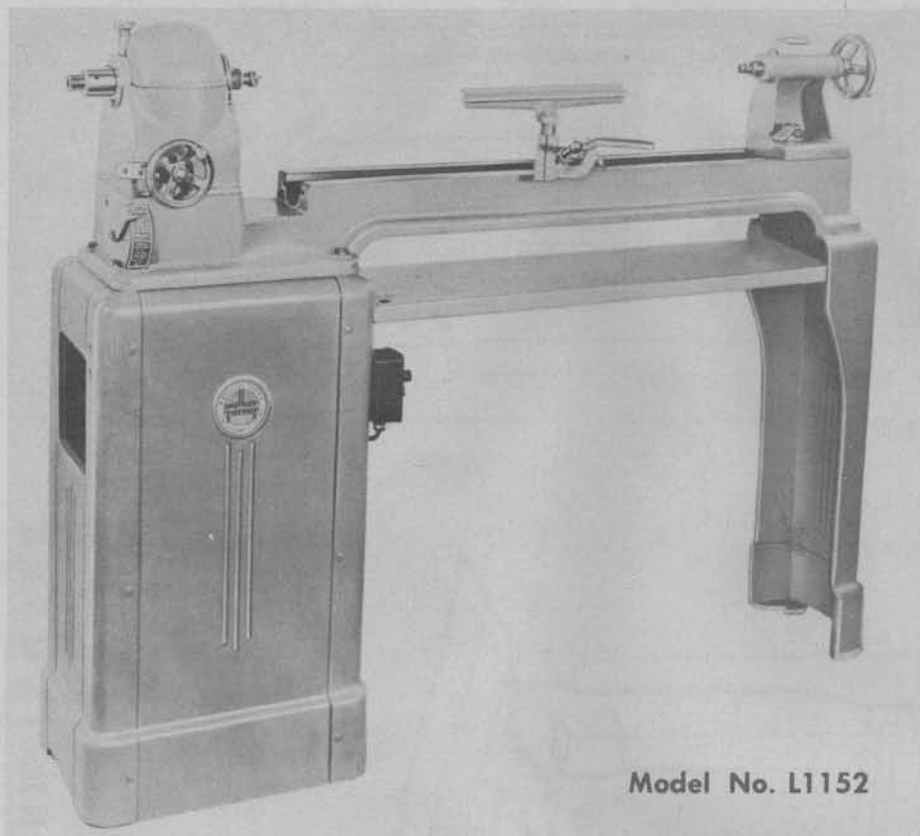

Model No. L1152



Model No. SVL52

SPECIFICATIONS

Capacity: • Swing, 15-1/2" over gap, 12" over bed.
• 38" between centers.

Spindle Speeds: 300 to 1300 R.P.M. with 2" motor pulley, 600 to 2600 with 4" motor pulley, in stepless gradients (using 1740 R.P.M. motor). Controlled by handwheel and shown by graduated scale.

Spindle: 1" O.D., 5/8" hole through its length; threaded right hand on inboard end and left hand on outboard end, 12 threads per inch. No. 2 Morse taper inboard.

Headstock: Cast iron, pulley and belt completely enclosed. Double row pre-loaded ball bearing at spindle nose, single row at opposite end, knurled thread-protector nut for inboard end. Positive type indexing plunger.

Tailstock: Cast iron, hand wheel feed, wedge type lock; tailstock center is automatically ejected.

Bed: Cast iron; two ways 1-3/8" wide, machined on top, inside and bottom. Width of bed across ways 5".

Tool Rest: Fully adjustable bracket includes permanent clamping wrench. One 12" and one 6" "T" furnished.

Base: Cast iron base encloses motor, includes wood shelf.

Standard Equipment: Model L1152—as shown, including base and motor bracket, one 6" and one 12" "T" rests, one spur center, one cup center, belts, and 2" or 4" motor pulley (see Spindle Speeds), less motor, switch and cord.

Model SVL52—as shown, including base and motor bracket, belts, and 2" or 4" motor pulley (see Spindle Speeds), less chuck, motor, switch and cord.

Models: L1152, woodworking, metaspinning.
SVL52, polishing

Overall Dimensions:

Model	Height	Width	Length
L1152	47"	12-1/2"	60"
SVL52	47"	12-1/2"	18-1/4"

Shipping Weight:

L1152	360 lbs.
SVL52	220 lbs.
Motor	32 lbs.

Electrical Equipment Recommended:

For single phase—

KAB5E 1/2 H.P. 115/230 volt, 60 cycle, 1740 R.P.M. single phase capacitor start motor.

TS5 On-off Toggle Switch for single phase only.
No. 14 Cord and plug for single phase only.

For three phase—

PAB5E 1/2 H.P. 220/440 volt, 60 cycle, 1740 R.P.M. three phase motor.

HD151A On-off push button switch for three phase or single phase motor.

Note: See regular catalog for complete accessories listing.

WALKER-TURNER DIVISION
PLAINFIELD



KEARNEY & TRECKER CORPORATION
NEW JERSEY, U.S.A.

DIMENSIONS

12" VARIABLE SPEED LATHES

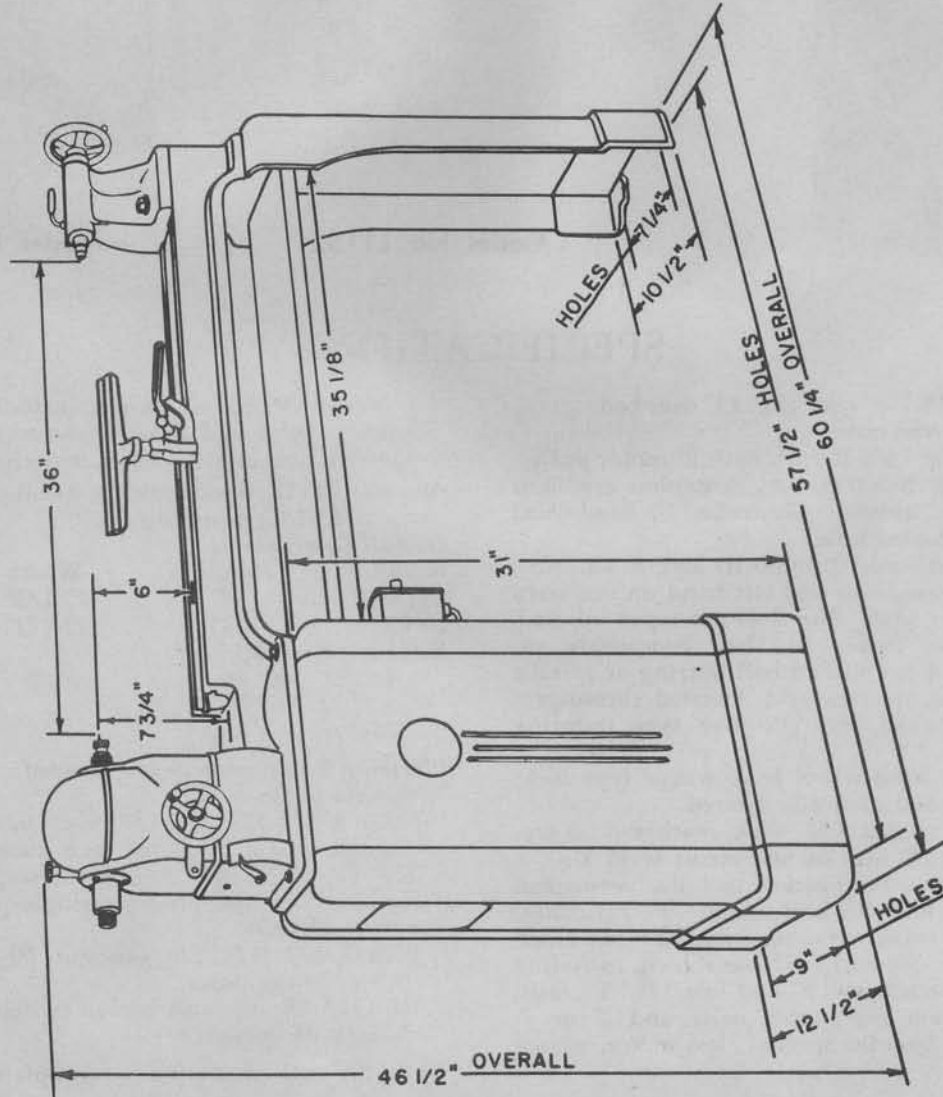

Model No. L1152

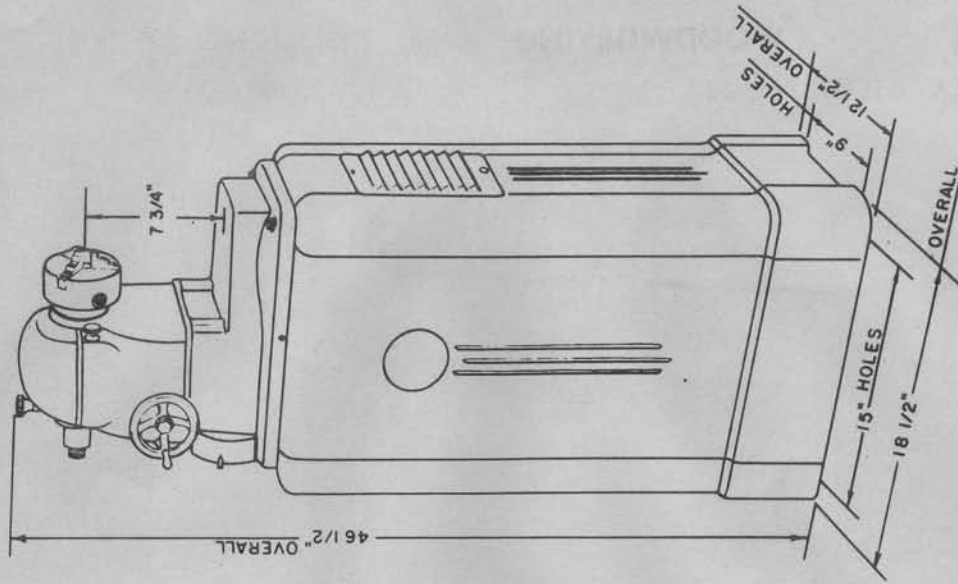

Model No. SVL52

WALKER-TURNER
 DIVISION
KEARNEY & TRECKER CORPORATION