

# POWER TOOLS

by  
Shopmaster



SHOPMASTER INC.  
MINNEAPQLIS, MINN

A COMPLETE LINE OF  
QUALITY POWER TOOLS  
FOR THE HOME AND  
PROFESSIONAL  
CRAFTSMEN

1953

# 10" Deluxe TILTING ARBOR SAW

TA-1200

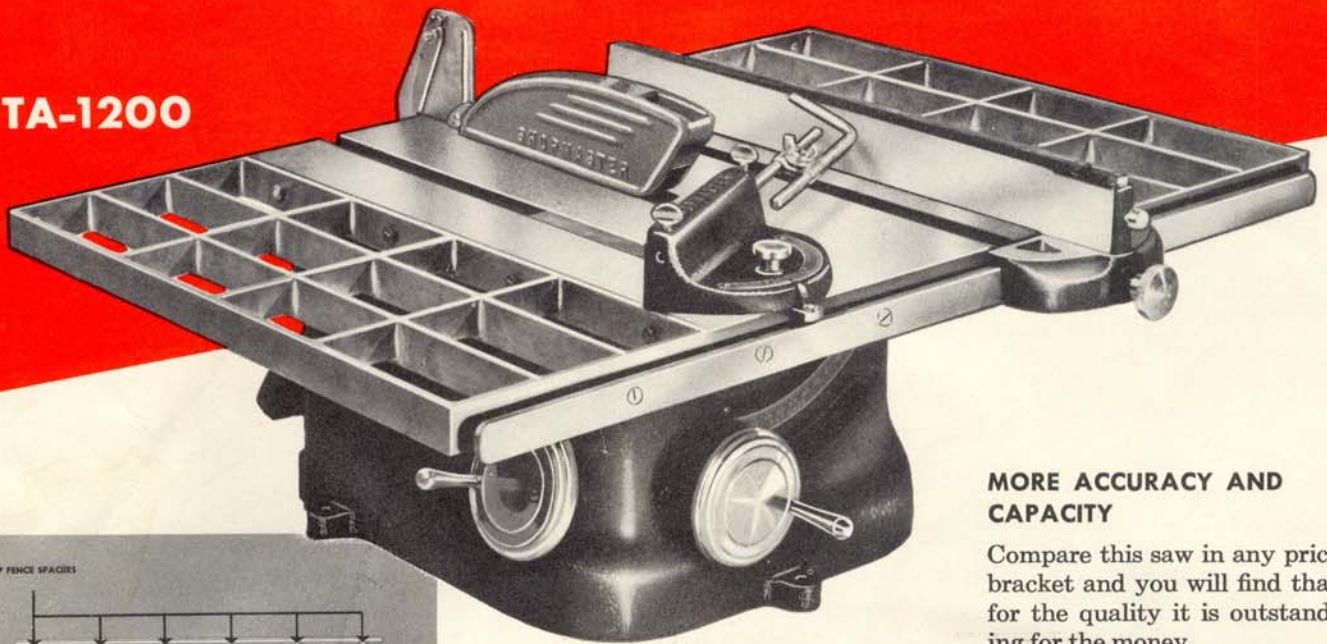

## MORE ACCURACY AND CAPACITY

Compare this saw in any price bracket and you will find that for the quality it is outstanding for the money.

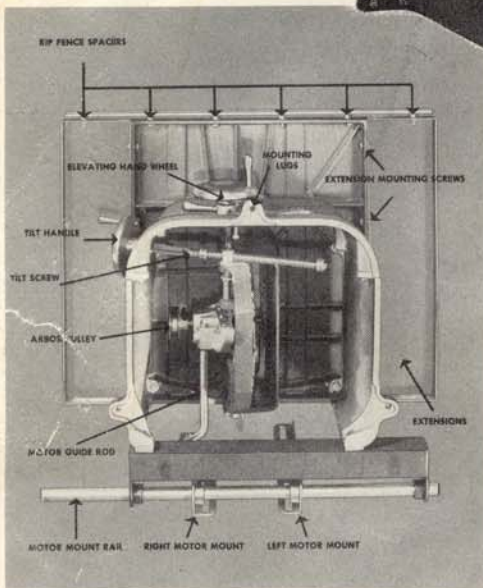

Base view of this saw shows tilting arbor mechanism and motor mount. This picture shows open construction as well as massiveness.

This big, husky SHOPMASTER 10" Saw is the ideal saw for the contractor, factory, or for the home workshop. This saw is of heavy cast construction, has ball bearings, giving long life and accuracy.

The 10" Tilting Arbor Saw has a large table, which includes extensions of 34 x 20". There are adjustable front table extensions which will make a total of 30 x 34" table area. This massive, well constructed unit has two sealed-for-life ball bearings on a 5/8" precision ground arbor and incorporated floating drive. This type of drive has been designed to facilitate larger motors when saw tilts to 45°. The larger frame motors will not tilt above table surface.

The Rip Fence is designed for easy adjustability. Also available is the long fence for locking on back of the table if desired. The lifting hand wheel, as well as the tilt hand mechanism, is precision built. The tilt screw, or lifting and lowering screw, is designed in open construction so as to insure a clean mechanism.



Our famous TS-90 All Purpose Stand, which is easy to move, is the proper stand for the home workshop, or professional workshop for the TA-1200.

## SPECIFICATIONS:

Depth of cut . . . . . 3 1/2"  
 Arbor tilts . . . . . 45°  
 Arbor size . . . . . 5/8"  
 Table size . . . . . 34 x 20" with extensions  
 Bearing type . . . . . sealed-for-life ball bearings  
 Blade size . . . . . 10"  
 Dado capacity . . . . . 13/16 x 6  
 Depth . . . . . 1 1/2"  
 Blade speed . . . . . approx. 4000 RPM  
 Base size . . . . . 17 x 15"

## Recommendations:

Motor. 1/2 or 3/4 HP (3/4 preferably) standard speed, depending on type of work to be done.  
 Motor pulley . . . . . 4"  
 Belt length. . . . . 39"  
 Type of belt . . . . . "A"

# 8" *Master Model* TILTING ARBOR SAW

EXTRA HEAVY DUTY RUGGED TILTING ARBOR SAW



TA-900

Better than 100,000 of these 8" Tilting Arbors have been purchased by satisfied consumers. Quality-Precision-Durability are the watchwords of SHOPMASTER'S acceptance in the home and professional fields.

The SHOPMASTER TA-900 8" Tilting Arbor Saw is known for its durability and complete cast construction. The table is of rugged cast construction; the base structure is of cast special aluminum alloy. The excellent design, out-standing quality and mechanical features make possible exceptional performance of this Tilting Arbor Saw.

Closely machined main arbor is held to precision tolerances. This arbor floats in two Norma Hoffman sealed-for-life ball bearings. The arbor size is  $\frac{5}{8}$ ". The Rip Fence is of special cast aluminum alloy. The Mitre Gauge has wide grooves and is of massive heavy construction and includes stop rods. The work always lies flat on the Tilting Arbor Saw and you can increase your work area with SHOPMASTER'S new table extensions. The  $8\frac{1}{2}$ " cast table extensions make possible an overall table size in width of 33", and with the front table extension a total length of the table is 30". We have testimonial proof from thousands of satisfied users.

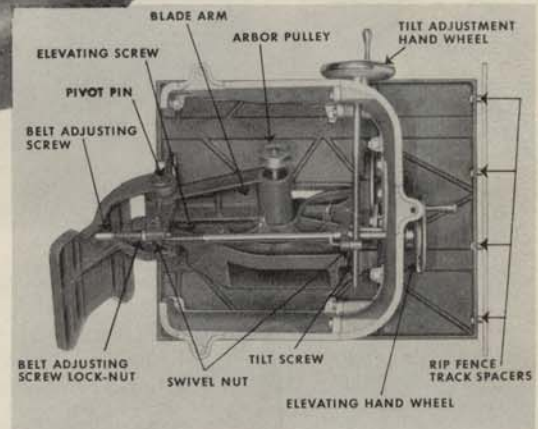

This is view of the tilting arbor mechanism. Motor Mount tilts with arbor. Tilt screws precision machined. Massive construction of arbor casting.



## SPECIFICATIONS:

Depth of cut . . . . .	2½"
Arbor tilts . . . . .	45°
Arbor size . . . . .	$\frac{5}{8}$ "
Table size . . . . .	16 x 20"
Bearing type . . . . .	sealed-for-life ball bearings
Base size . . . . .	17 x 15"
Blade size . . . . .	8"
Dado capacity . . . . .	$\frac{5}{8}$ " width
Dado capacity . . . . .	13/16 x 6
Blade speed . . . . .	appro. 4000 RPM

## Recommendations:

Motor . . . . .	½ HP, standard speed
Motor pulley . . . . .	4"
Belt length . . . . .	39"
Type belt . . . . .	"A"

# SHOPMASTER'S

## New

### 8" TILTING ARBOR SAW



**TA-5800**

**Super value,  
and recognized  
outstanding  
SHOPMASTER  
quality.**

Sealed-for-life ball bearings, massive heavy duty construction make possible exceptional accuracy. Note the well constructed assembly. Note improved motor mounting, enabling large framed motors without motor tilting above table on 45 degrees. Note improved tilting gear and elevating mechanism insuring ease of operation.

**SHOPMASTER** Tools are famous. Better than 200,000 Circle Saws in both Tilting Arbor and Tilting Table are used by satisfied **SHOPMASTER** customers.

**Specifications:** Table size 13 x 16. With front and side extensions, table can be made 23 x 26. With front and Deluxe side extensions, table can be made 28 x 26. Cuts 2 1/2", tilts 45°, 1/2" arbor. Made of famous special light-weight aluminum alloy. Recommended belt, 30": pulley size, 4"; recommended motor 1/3 or 1/2 HP, depending on type of work to be done.

#### LOOK AT THESE FEATURES

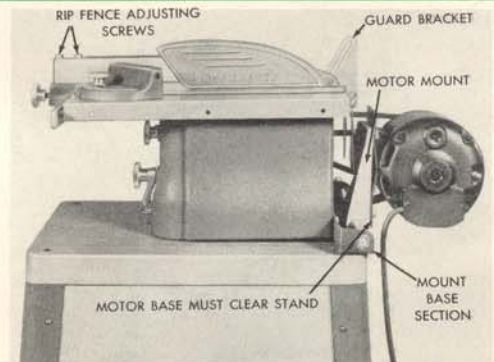

Note the improved and adjustable rip fence, type of improved motor mount, and outstanding engineering in new type tilting arbor mechanism for more positive controls. Motor, motor pulley and belt not included in price.



As pictured mounted on our new TS-90 All-Purpose Stand, assists easy movement of tool. Table Extensions available.

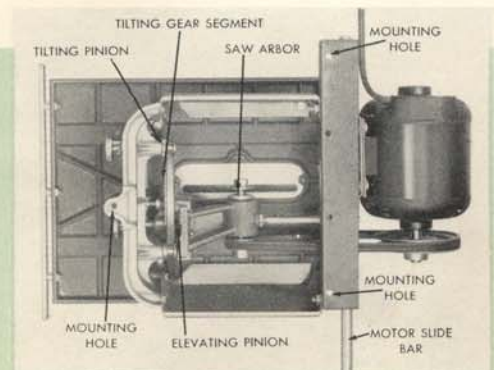

# SHOPMASTER'S

*New*

## 8" TILTING TABLE SAW

**CS-5200**



**The Circle Saw . . .  
the important tool  
to the beginner.**

**This priced, quality tool is  
designed especially for the  
home workshop**

Here's a table saw of the usual SHOPMASTER durability and quality. Featuring price, and a large working surface. Ease of operation is attained by free swinging positive trunnions and lifting mechanism. Extensions and accessories are available.

Specifications: Oilite bearings, table size 13"x16". With extensions table can be made to 23"x26". Cuts 2½", tilts 45°, ½" arbor. Recommended motor pulley 4"; recommended motor, standard speed ⅓ or ½ HP depending on type of work to be done.



**This is new added feature with all  
SHOPMASTER saws.**

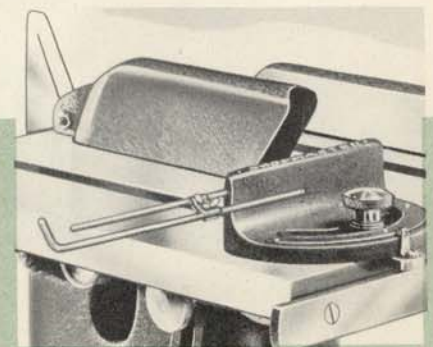

**HAVE A COMPLETE SHOPMASTER SHOP  
QUALITY — PRICE — SATISFACTION — GUARANTEE**

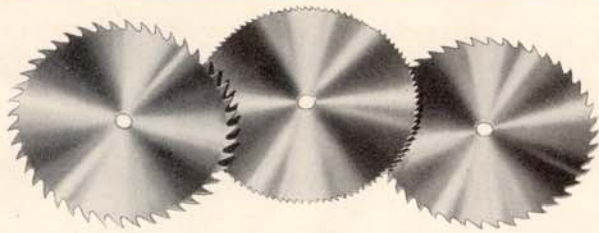

**CIRCULAR SAW BLADES.** Manufactured of highest quality steel. Scientifically heat treated and hand peened. Set with the correct tooth shape for faster, cleaner sawing. Have a spare blade on hand for your saw. It will save time if you should hit a nail or dull your present blade.

- |  |  |
|--|--|
| Y-126 8" Combination Blade               | Y-1226 10" Combination Blade               |
| Y-127 8" Cross Cut Blade                 | Y-1227 10" Cross Cut Blade                 |
| Y-128 8" Rip Saw Blade                   | Y-1228 10" Rip Saw Blade                   |
| Y-129 8" Hollow Ground Combination Blade | Y-1229 10" Hollow Ground Combination Blade |
| Y-1325 7" Combination Blade              |  |

**Y-132—SHOPMASTER'S 8-TOOTH, 8" CARBIDE-TIPPED SAW BLADE.** Here is a lasting saw blade tipped with hardened carbide. This blade eliminates a great deal of sharpening and will outlast steel blades many times. SHOPMASTER'S carbide-tipped blades are high in quality, yet priced to meet your satisfaction.



**DADO SETS FOR CUTTING GROOVES.** Made of same steel as all SHOPMASTER saw blades. Two styles to choose from. Both have  $\frac{5}{8}$ " bore to fit most standard saws.  $\frac{1}{2}$ " adapter rings included.

- |  |   |
|--|---|
| Y-136 "A" Dado Set—two outside saw blades with chippers, $\frac{5}{8}$ " bore. | Y-137 "B" Dado Set—has solid type structure of outside blades in nickel content in steel. |
|--|---|



**Y-133—8" SANDING DISC**  
8" Sanding Disc that is adaptable to your 8" or 10" saw. You can do disc sanding on your present SHOPMASTER unit or any other make saw you may have. (Made of sturdy stamped steel construction.)

**Y-133D—SANDING DISC FOR 8" DISC**

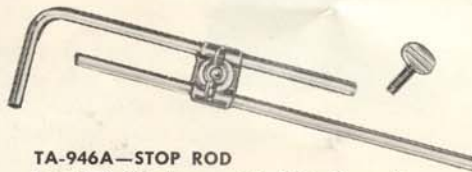

**TA-946A—STOP ROD**  
Stop Rod. Fits the new style Mitre Gauge for repetition cutting.

**TABLE INSERTS**

- TA-938 for TA-5800 and CS-5200  
TA-1245 for TA-1200 and TA-900

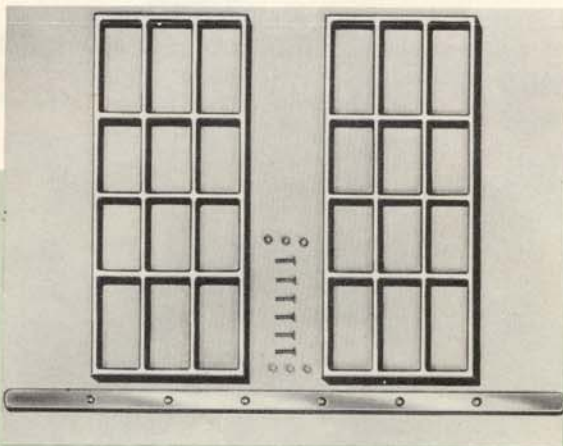

The new DeLuxe Extensions add  $8\frac{1}{2}$ " additional width to your saw on each side, 17" overall to your saw. Of webbed, cast construction, complete with bolts and rip fence, ready to attach to your SHOPMASTER saw.

- TE-1211—Fits TA-1200, TA-900. Size— $8\frac{1}{2}$ "x20"  
TE-5811—Fits TA-5800, CS-5200. Size— $8\frac{1}{2}$ "x16"

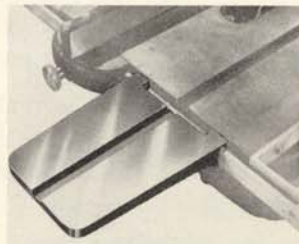

**FRONT TABLE EXTENSIONS (FE-1210).**

Fits all SHOPMASTER saws and adds 10" working surface to front of all saws. Can also be used on our 12" Band Saw. (Here's an added feature at a reasonable price that can be added to your equipment, and will more than pay for itself many times over.)



**Y-200—SHOPMASTER'S MOULDING HEAD FOR CIRCLE SAWS.** Make moulding on your circular saw.  $\frac{1}{4}$ " or  $\frac{3}{8}$ " arbor.

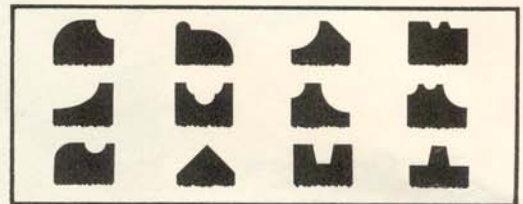

Cutters to fit Moulding Head in 12 different designs, of special hardened steel. Numbers, top row left to right.

- |  |                           |
|--|---------------------------|
| Y-201 Cove Cutter                                | Y-206 Screen Mould Cutter |
| Y-202 Crown Mould Cutter                         | Y-207 Bead Cutter         |
| Y-203 $\frac{1}{2}$ " Radius Bead and 45° Cutter | Y-208 Panel Strip Cutter  |
| Y-204 Glue Joint Cutter                          | Y-209 Glass Top Cutter    |
| Y-205 Bead Cutter                                | Y-210 45° Flute Cutter    |
|  | Y-211 Tongue Cutter       |
|  | Y-212 Groove Cutter       |



**TA-1227—LONG RIP FENCE GUIDE.** Here's a rip fence that will lock on the back of your present 8" or 10" Tilting Arbor Saw. Some customers desire to have this type. Cast construction.

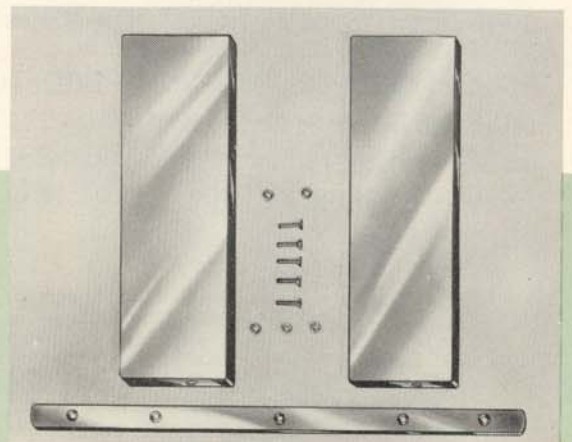

**TABLE EXTENSIONS.** For greater work surface on your table saw. Complete with bolts ready to attach to your SHOPMASTER saw. The two add a total of 10".

- Master Models: TE-110—For CS-100 Saw, 5"x18"  
TE-910—For TA-900 Saw, 5"x20"  
TE-1310—For TA-5800 and CS-5200, 5"x16"

# CIRCLE SAW *Accessories*

ADD ACCESSORIES TO YOUR CIRCLE SAW — IT INSURES WIDER RANGE OF OPERATION



More and more people are adding convenience and versatility to their shop equipment—the picture shows the 8" tilting arbor saw mounted with extensions, dado, stop rod, stand and

dust bag. Of course, the same can be applied to all our Circle Saws. This is the finest equipment money can buy, yet within budget prices.

**Deluxe in quality — SHOPMASTER accessories are sold through all SHOPMASTER Dealers**

# 6" BALL BEARING

# JOINTER-PLANER

PROFESSIONAL MODEL

JO-400

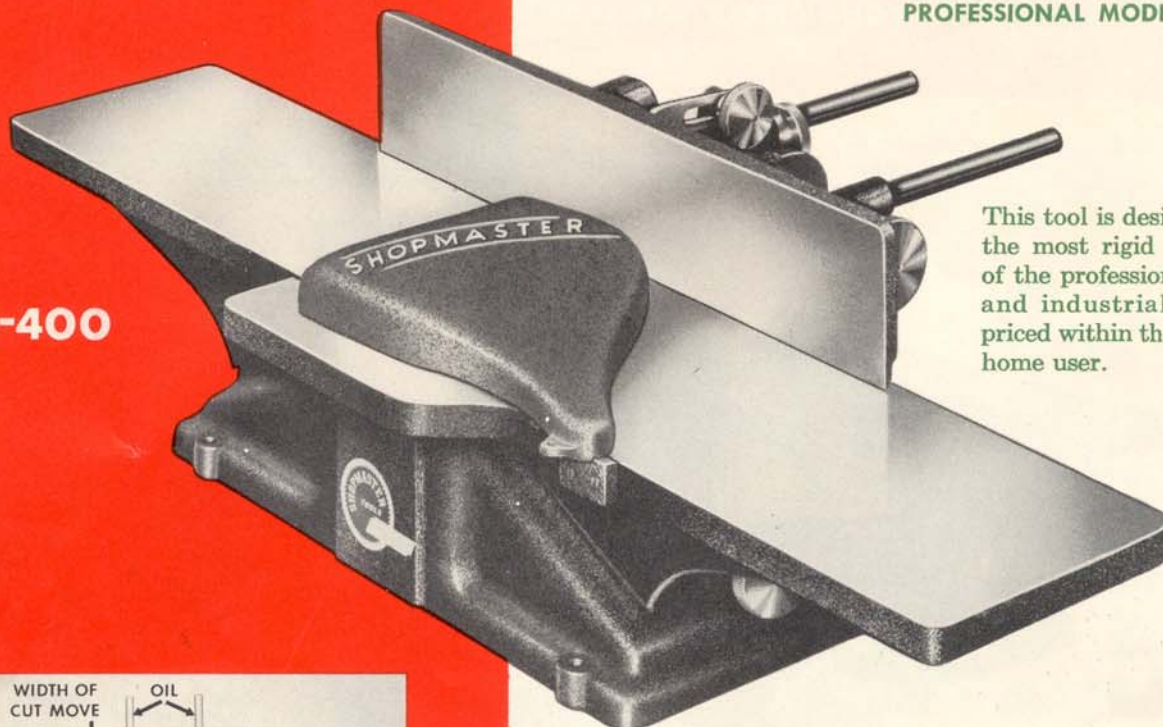

This tool is designed to meet the most rigid requirements of the professional craftsmen and industrial shops, yet priced within the range of the home user.

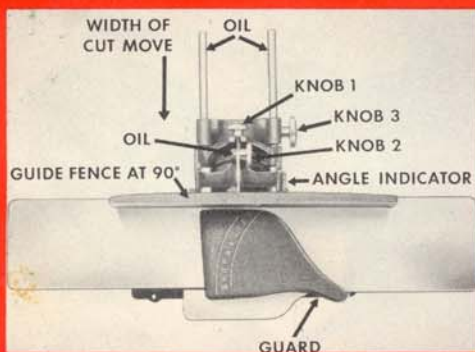
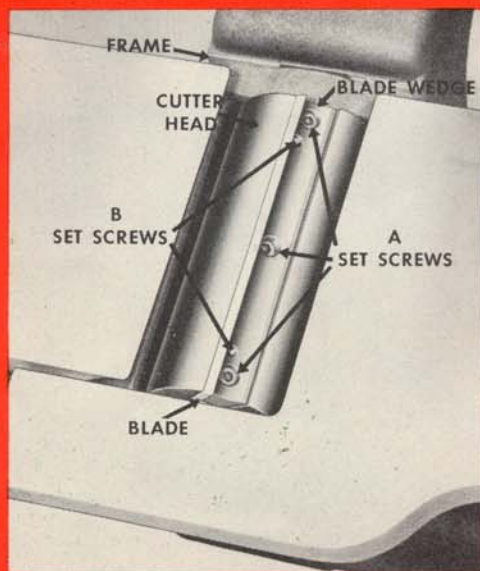

Photo indicates the ease of adjusting SHOPMASTER Blades, which insures more accuracy.



Above photo shows the complete blade coverage and guard coverage, also the accessibility of operating mechanism. Compact, sturdy, precise, precision built.

Save yourself that work of hand-planing with a SHOPMASTER 6" ball bearing Jointer. This Jointer has the most advanced cutting head of any Jointer in its class. Knives can be easily set to perfect adjustment, by turning adjusting screws. (Note picture.) Both tables move for ease of alignment. Tables are 17" long to take large work and will surface up to 6" wide with  $\frac{1}{2}$ " cut. Fence is positively locked in the center to prevent twist, and will tilt  $45^\circ$ . Knives are made of the finest high speed steel for long life. Never before has so much attention been given to capacity and performance on this type of equipment. The specially designed guard gives maximum protection at all positions. Guard easily removed.

## SPECIFICATIONS:

Capacity (Width of Cut).....6"  
 Depth of Cut..... $\frac{1}{2}$ "  
 Table (Front).....17"x8 $\frac{1}{2}$ "  
 Overall Length.....34"  
 Ball Bearings..... Sealed-for-Life  
 Height.....9 $\frac{1}{2}$ "  
 Width.....20 $\frac{1}{2}$ "  
 Rip Fence Length.....20"  
 Rabbets..... $\frac{1}{2}$ "

## Recommendations:

Motor... $\frac{1}{3}$  or  $\frac{1}{2}$  HP, Stand-  
 ard Speed  
 On 1750 RPM Motor, 5" Pul-  
 ley will revolve head at 4325  
 RPM. Complete as illustrated,  
 less Motor and Motor Pulley.  
 Weight...58 lbs.

## ACCESSORIES:

SHOPMASTER Jointer Knives (Y-421) for the 6" Jointer are made of finest high speed steel ground and honed to a keen cutting edge. These knives will give long service and retain cutting edge longer than most knives. Sold in sets of three, 6" long. Weight... $\frac{1}{4}$  lb.



# 4" BALL BEARING

Your best buy is SHOPMASTER

# JOINTER-PLANER

SEALED FOR LIFE  
BALL BEARINGS  
HEAVY DUTY

JO-1500

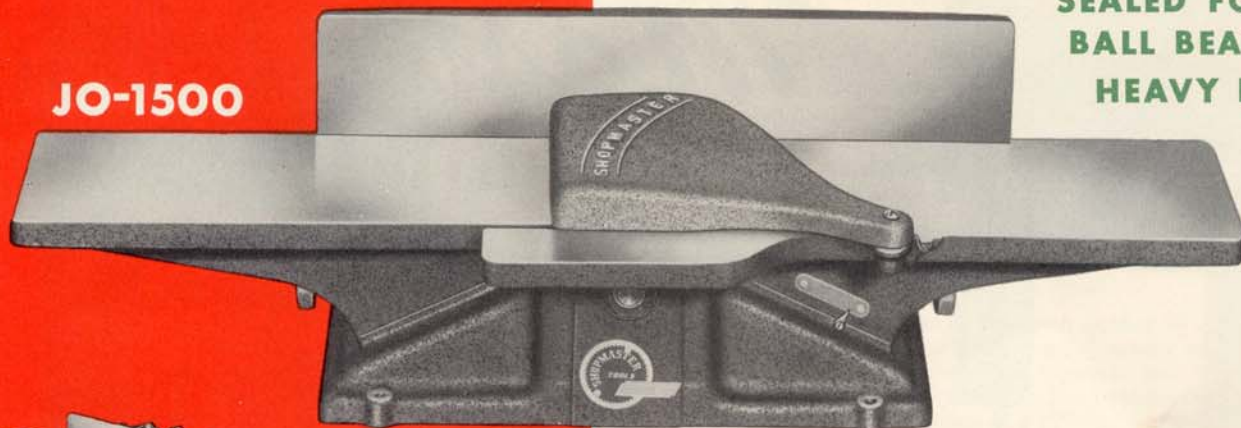

Picture at left indicates individual mounting on TS50A Stand. Picture below shows mounting of 8" Tilting Arbor Saw and 4" Jointer with one motor on TS-99 Dual Stand.



Most of the fun of a home shop is doing smooth and nice work. A Jointer will save tedious hard planing, and speed your projects. There is no sacrifice in quality in this 4" Jointer. It is built to SHOPMASTER's same high standard of workmanship. Cutter head is mounted on sealed-for-life ball bearings and is equipped with three high-speed steel knives, sharpened and honed for precision work. Both tables are adjustable for all types of work. Fence tilts and has accurate scale for setting. Guard may be removed for cutting rabbets to a depth of  $\frac{3}{8}$ ". This tool will plane boards up to 4" wide faster and easier than by hand. Buy this tool and save time and energy.

## SPECIFICATIONS:

Depth of Cut.....	$\frac{3}{8}$ "
Overall Length.....	26"
Table Width.....	4"
Height.....	7 $\frac{1}{2}$ "
Ball Bearings.....	Sealed-for-Life (2)
High Speed Steel Knives.....	3
Jointer complete with knives, fence, jointer pulley, less motor and motor pulley.	
Weight... 28 lbs.	

## ACCESSORIES

Jointer Knives (Y-1521) for the 4" Jointer are made of high speed ground steel. Sold in sets of three.....Weight...  $\frac{1}{4}$  lb.

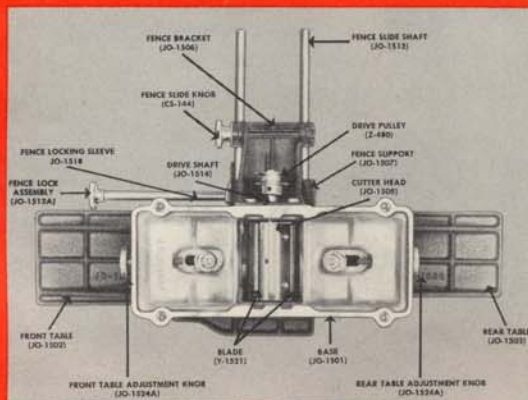

Picture at the side shows the 4" Jointer and its mass construction denoting all locking mechanism and base construction as well as table construction. Note the heavy cast ribbed all special aluminum alloy, spring tension controls on table riding slots. Easy accessibility of drive pulley, knob controls as well as rear table and front table adjusting knobs. All of these SHOPMASTER features are reasons for its exceptional customer acceptance.

# SHOPMASTER

## Masterpiece

### 12" TILTING TABLE BAND SAW RUGGED ALL CAST FRAME

SHOPMASTER 12" Band Saw is almost a complete shop in itself. It will crosscut and rip lumber, as well as make involved curved or circular cuts. Ball bearing wheels and hardened steel thrust guides give long life and complete dependability. Wheels are rubber tired and dynamically balanced. Table tilts to 45° and has mitre gauge slot, and is drilled for rip fence. Blade is protected with guard which is adjustable to allow cuts up to 6 1/8" thick. All mechanism is fully enclosed with easily removed wheel covers. Upper wheel is adjustable both for tension and tilt. This saw is the ideal tool for all shops.

#### SPECIFICATIONS:

Cuts to Center 24" Circle	12 1/8"
Capacity in Depth	6 1/8"
Capacity in Height	.78"
Blade Length	12" x 12"
Table Size	12" x 18"
Table Work Surface	45°
Table Tilts	Sealed-for-Life (4)
Ball Bearings	35 1/2"
Height of Saw	12"
Width of Saw	23 1/4"
Length	58 lbs.
Shipping Weight	

#### Recommendations:

Motor.. 1/4, 1/3 or 1/2 HP,  
Standard Speed, de-  
pending on type of  
work to be done.  
Motor Pulley..... 2"

*Cuts Wood, Metal, Plastic, Etc.*

**SB-200**



Above photo shows integral part of the SHOPMASTER Blade guides. Shows the hardened steel thrust guide as well as the brass side guides and longitudinal guides. It also incorporates exceptional trunnion construction. Upper guide same construction.



TA-1305A Mitre Gauge. Fits either the 10" or the 12" Band Saw, Sander, Shaper, and all SHOPMASTER Tools.



SHOPMASTER Blades are manufactured of finest steel.

Blades are individually packed and are 78" long.

- 1/8" Band Saw Blade SB207-1
- 3/4" Band Saw Blade SB207-2
- 3/8" Band Saw Blade SB207-3
- 1/2" Band Saw Blade SB207-4

Special length blades are available for other makes of saws.



CA-210 SHOPMASTER Band Saw Circle Cutting Attachment. Will cut circles from 2" to 10".

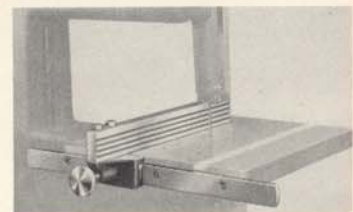

SB250A Band Saw Rip Fence Assembly. It permits ripping lumber more quickly and accurately.

# 10" TILTING TABLE BAND SAW

EXTRA HEAVY DUTY — SMOOTH — QUIET OPERATING — ACCURATE



This all cast tool of a special aluminum alloy insures accurate, smooth running operations. The entire frame, as well as the cover, is cast in one piece. This makes possible a rugged 10" Band Saw in which all working parts are enclosed. It has the same blade guide construction as the 12" Band Saw. This type of guide construction is used on more expensive models.

SHOPMASTER Tools are designed by some of the foremost designing engineers in the country today. Pleasing design, pleasing SHOPMASTER green wrinkle finish.

You'll be amazed at the type and quality of work you can do with this saw. Nearly every type of sawing can be done with a Band Saw—cross cutting, ripping, and involved curved cuts. In addition to wood, metal and plastic can be sawn. This saw will cut to the center of a 20" circle, and will cut stock up to 5" thick. When you start your shop, be sure to see this SHOPMASTER Band Saw.

## SPECIFICATIONS:

Table Size.....	10"x10"
Depth of Cut.....	5"
Blade Size.....	1/4"
Blade Length.....	64"
Table Tilts.....	45°

## Recommendations:

Motor.....	1/4 HP
Motor Pulley.....	2"
Shipping Weight.....	38 lbs.

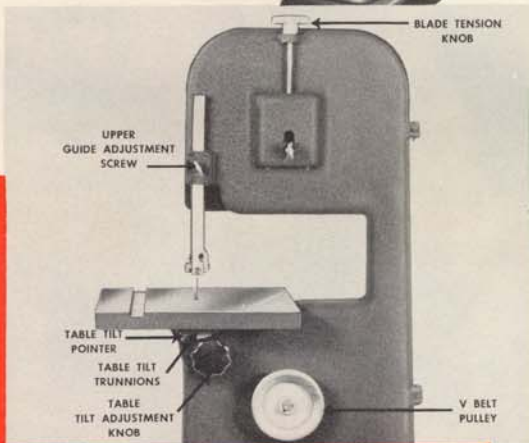

Photo shows the accessibility of the table tilting trunnions, locking mechanism and totally enclosed unit of special all-cast aluminum alloy.

## THE BAND SAW IS VERSATILE

The SB250A Rip Fence fits the 10" Band Saw, as does the TA1305A Mitre Gauge and CA210 Circle Cutting Attachment.



SHOPMASTER 10" Band Saw Blades of high quality steel. Skip tooth, 63", for metal or wood.

- 1/8" Band Saw Blade SB1420-1
- 1/4" Band Saw Blade SB1420-2
- 3/8" Band Saw Blade SB1420-3
- 1/2" Band Saw Blade SB1420-4

# The \* UNIVERSAL INDIVIDUAL COMBINATION

**CU-6000**

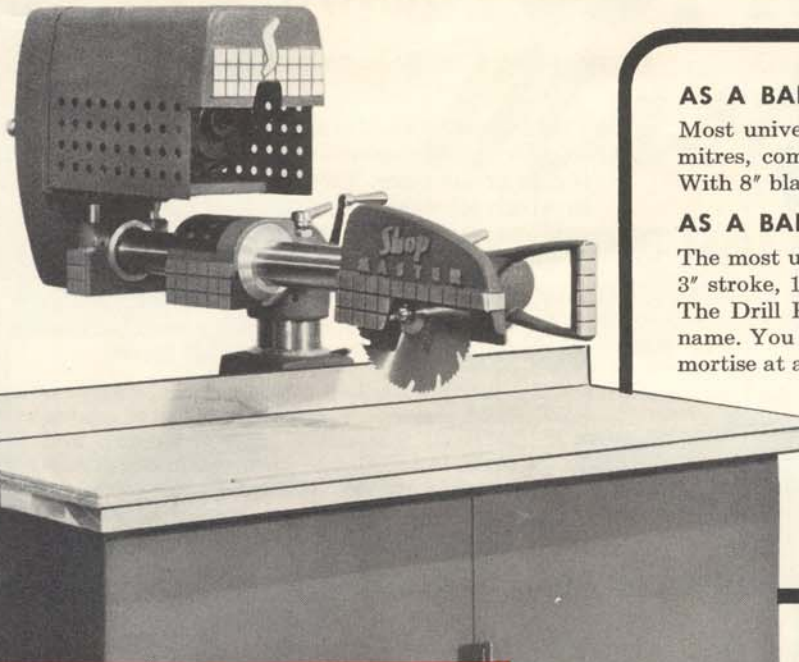

**AS A BALL BEARING CIRCLE SAW—**

Most universal tilting arbor or pull saw type. It mitres, compound mitres, crosscuts, dados, rips. With 8" blade—3" cut.

**AS A BALL BEARING DRILL PRESS—**

The most unusual versatile tool of its kind. With 3" stroke, 18" throat, you can drill at any angle. The Drill Press routs. You can even write your name. You can drill in any given radius. You can mortise at any angle. It is a shaper with universal applications. It is a horizontal or a vertical machine.

**AS A BALL BEARING SANDER—**

You can sand horizontal, vertical or as a thickness sander.

**SPECIFICATIONS**

<b>Stand</b>	
Length . . . . .	48"
Width . . . . .	28"
Height . . . . .	34"
Sub-table . . . . .	48"x18"
<b>Speed range on all tools</b>	
700 to 4000 RPM with standard speed 1750 RPM motor	
Height adjustment on column arm . . . . .	12"
<b>Circle Saw—8" Combination</b>	
Depth of cut . . . . .	2 3/8"
Degree of cut . . . . .	45°
Compounds miters to 45°	
Rips to center of 48°	
Draw of radial arm . . . . .	16"
<b>Drill Press</b>	
Drills to center of 42"	
Throat . . . . .	21"
Radials at any angle	
6 Spline floating spindle in 2 sealed-for-life ball bearings	
Depth of thrust . . . . .	3"
Height adjustment . . . . .	12"
Drill from floor area . . . . .	44"
<b>Sander—10" Disc</b>	
Table Tilts . . . . .	45°
Radials to 90° . . . . .	
Belt . . . . .	4"
Radials in any angle	

*Additional Information write for complete catalogue*

\*Pat. Pending

**"It's Universal"**

- CIRCLE SAW
- DRILL PRESS
- SANDER
- SHAPER
- ROUTER
- LATHE
- JOINTER
- GRINDER
- BUFFER

**POWER PLANT—  
ALL IN ONE.**

**EASY TO CONVERT**

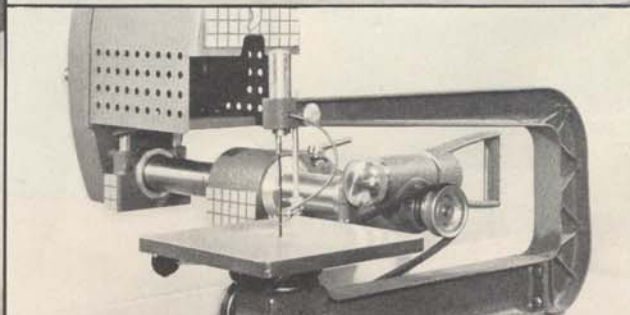
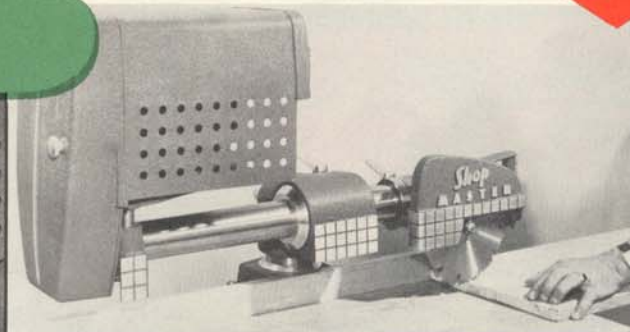
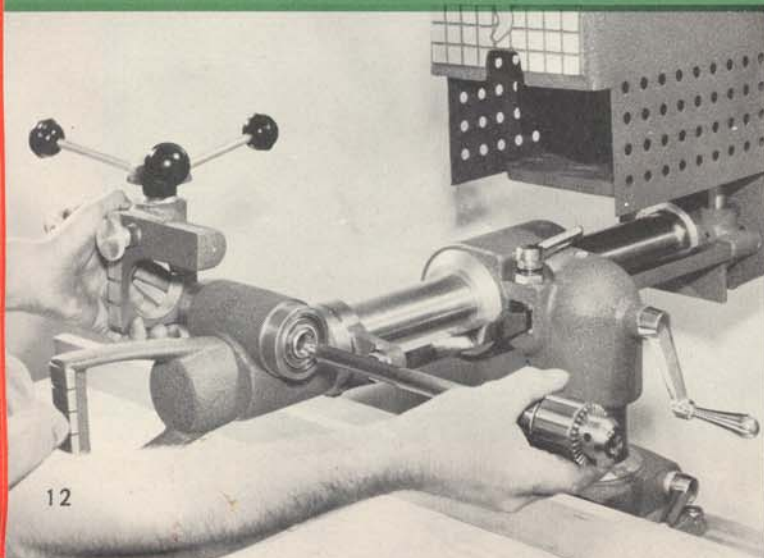

# POWER TOOL

One of the most advanced mechanical designs in woodworking tools. Simple easy changes make possible individual universal tool. The complete universal home workshop. Each tool ball bearing.

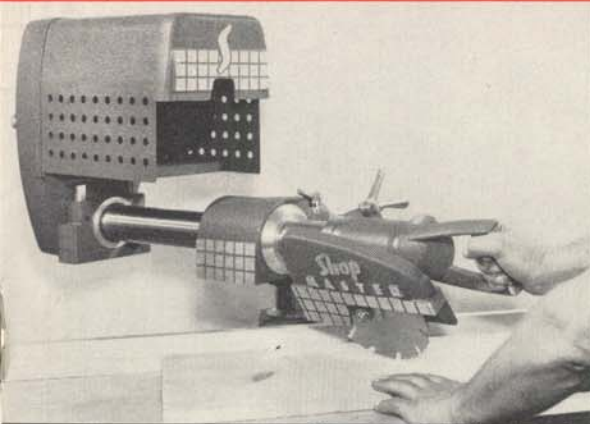

## CIRCLE SAW

It's more versatile than any type of 8" Circle Saw.

### *The Unusual*

You can actually cut a cup shape with your Circle Saw Blade by simply operating as pictured.

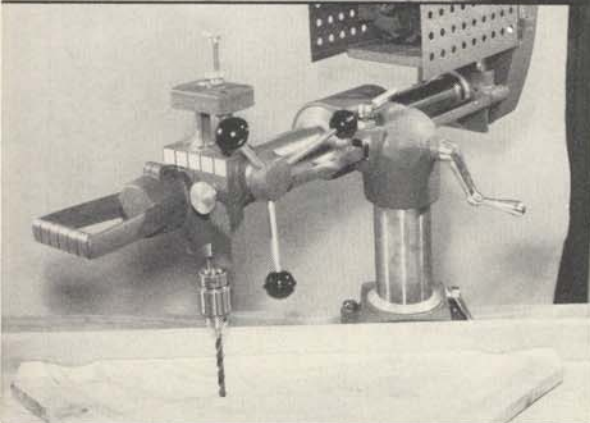
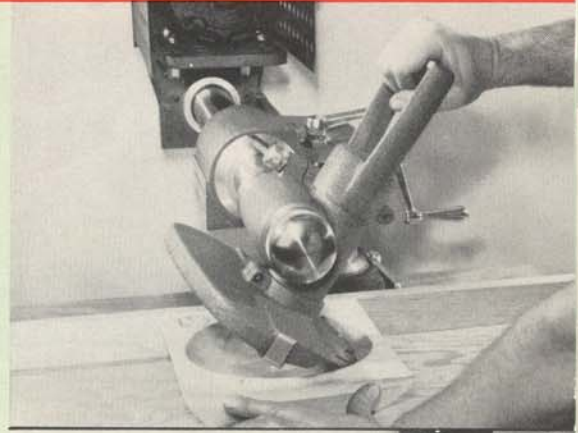

## DRILL PRESS

It will drill in any radius or any angle desired. It is precision and of the finest professional quality. Accurate.

### *The Unusual*

You can actually write your name with the router bit mounted in the safety type chuck by moving the head any direction.

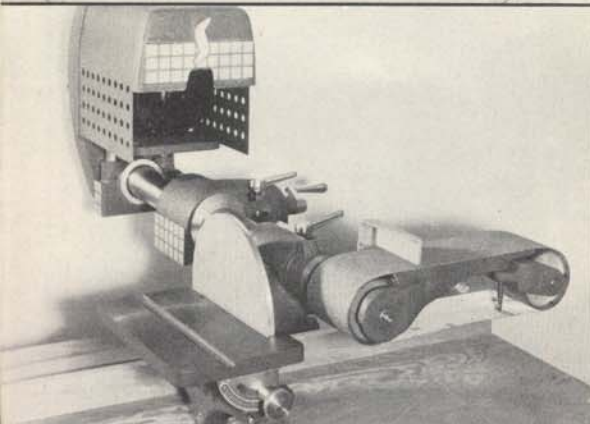
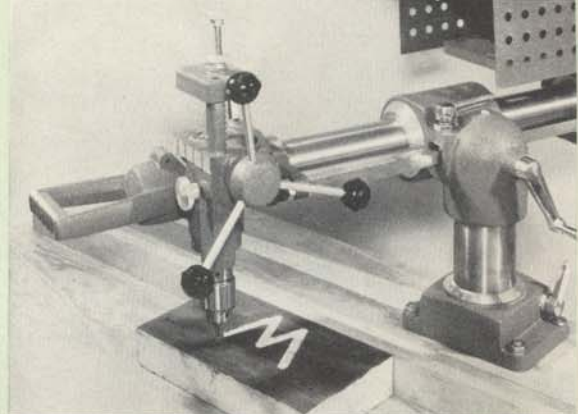

## BELT & DISC SANDER

As a Combination Belt and Disc Sander. Ball bearing construction. Precision built.

### *The Unusual*

Surface sanding in vertical or horizontal position with quick easy changes.



## SPEED CHANGES

Four-step speed changes.

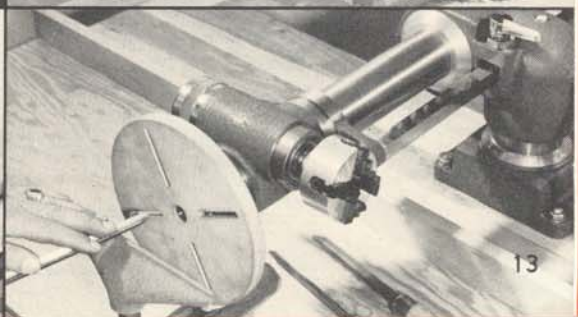
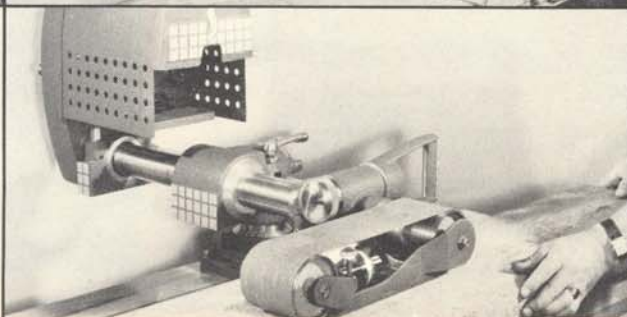
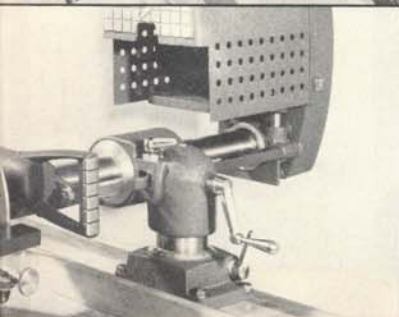
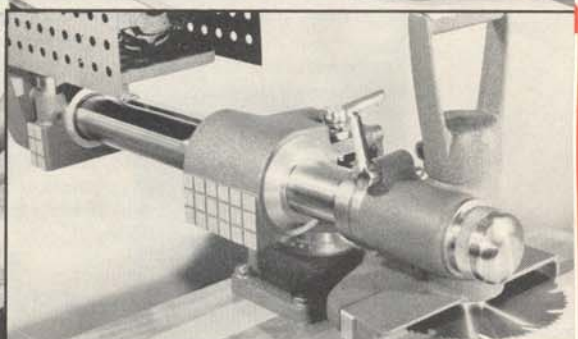
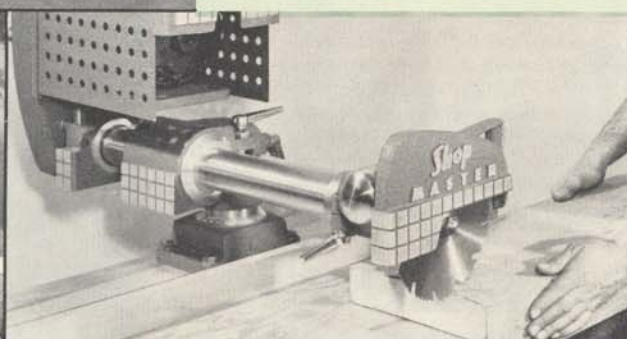
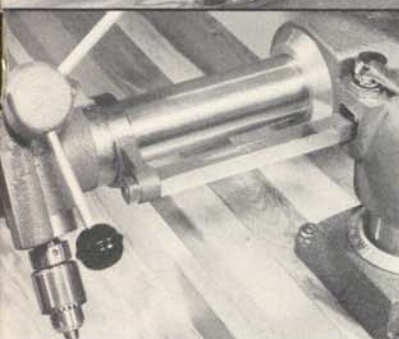

# SHOPMASTER'S *New* 20" TILTING TABLE JIG SAW

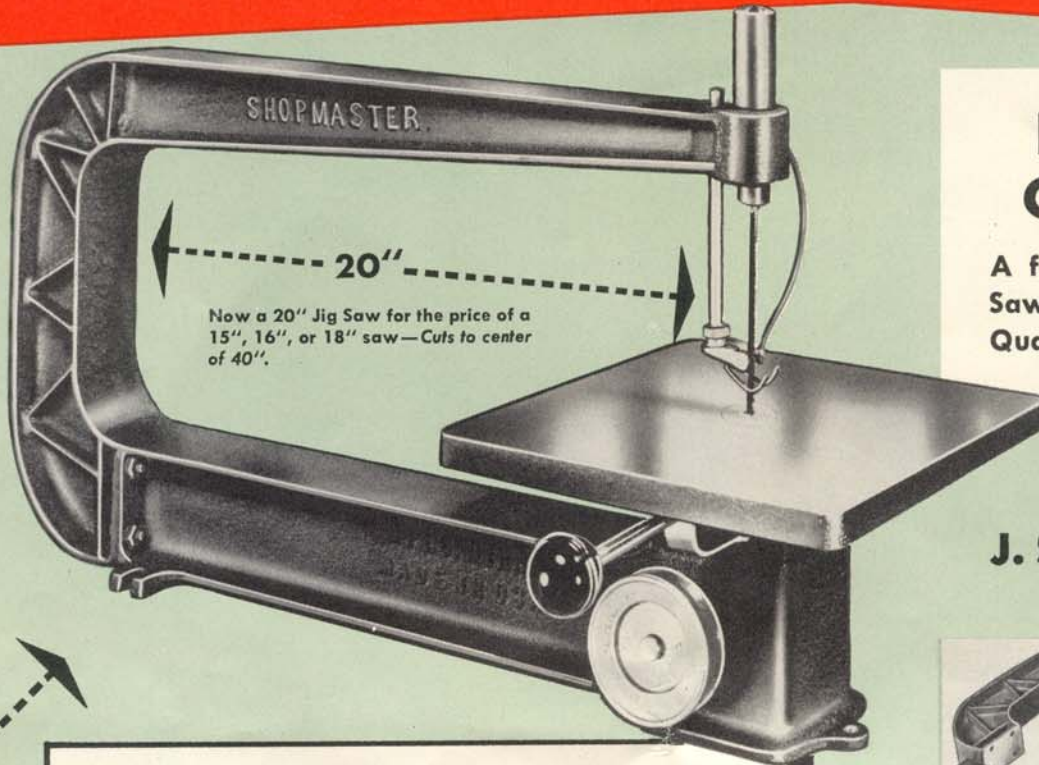

Now a 20" Jig Saw for the price of a 15", 16", or 18" saw—Cuts to center of 40".

*The NEW 20" JIG SAW* can be converted into a Saber Saw by simply releasing the mounting screws.

## PRICE & QUALITY

A feature buy in the Jig Saw Market—It's Big—It's Quality—It's Guaranteed.

**J. S. 3000**

## IT'S 20", AND IT'S SMOOTH

The SHOPMASTER Jig Scroll Saw makes an ideal tool for both the professional and the amateur wood worker. Accuracy is insured by rugged construction. Blower and spring mechanism entirely enclosed. Easily adjusted blade guide, plus blower tube and tension foot arrangement is an outstanding feature of the SHOPMASTER Jig Saw. The table tilts 45° on a new cam locking type table trunnion, and the upper and lower chucks have facilities for turning to longitudinal cuts. There is no Jig Saw comparable to the SHOPMASTER Jig Saw in price, size or quality. The Scotch yoke type action insures smooth, quiet operation. Runs in bath of oil. The unit is built from special aluminum alloy with unusual high tensile strength.

SHOPMASTER is one of the predominating names in the home work shop field.

### SPECIFICATIONS:

Table Size . . . . .	10 x 10"
Table Tilts . . . . .	45°
Depth of Capacity . . . . .	20"
Depth of Capacity to center of circle . . . . .	40"
Capacity in height of cut . . . . .	2 3/4"
Blade Vise . . . . .	Split Chuck Type
Guides . . . . .	Hardened Groove Rollers
Tension Foot . . . . .	Tempered Spring Steel

### RECOMMENDATIONS

Motor . . . Standard Speed, 1750 RPM, 1/4 HP Motor  
Pulley—2". Weight . . . 22 lbs. Belt Type . . . "A".

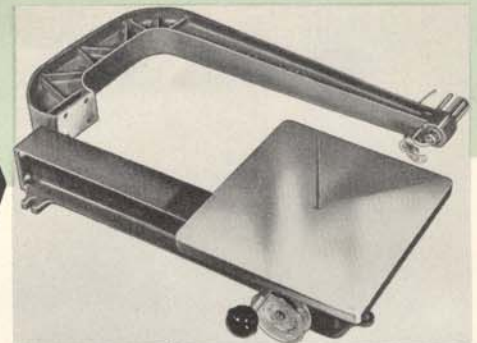

PROMINENT  
FEATURES OF  
JIG SAW  
HEAD AND  
GUIDE  
MECHANISM

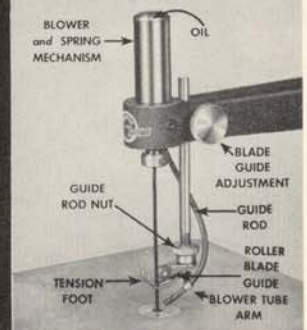

PROMINENT  
FEATURES OF  
JIG SAW  
TABLE AND  
LOWER GUIDE  
MECHANISM

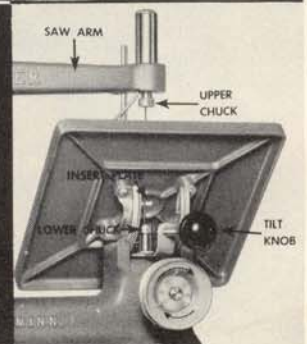

# SHOPMASTER SABER SAW

**SIMPLICITY IN DESIGN,  
EASE OF OPERATION,  
FOR THE YOUNGEST WOODWORKER  
IN THE FAMILY**

The SHOPMASTER Saber Saw is the simplest of all tools to operate. Its simplicity makes it ideal for the professional as well as the youngest woodworker in the family. This versatile tool can be used in a great variety of work, from straight sawing to complicated internal cutting. The entirely new design of this saw permits cutting of stock up to 1½" thick, and there is no limit to size of the piece that can be sawn. Its design eliminates the overarm above the table so large panels can be easily cut. The table tilts to any angle up to the full 45°, and can be quickly adjusted to desired angle with quick-action table lock.



**SS-700**

## SPECIFICATIONS:

### Recommendations:

Motor... ¼ HP or Smaller, Depending on Type of Work, Standard Speed Motor Pulley 2"

Table Size.....10"x10"  
Depth of Cut.....1½"  
Blade Vise.....Roller Type  
Table Height.....6⅝"  
Width.....10"  
Length.....10"

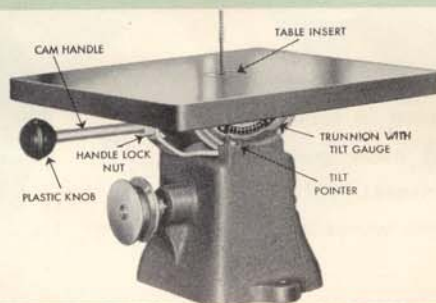

### COMPLETE LESS, MOTOR

Photos indicate the master construction of the SHOPMASTER Saber Saw. Indication of the type of blade guide, chuck, and trunnion construction, and improved cam table lock.

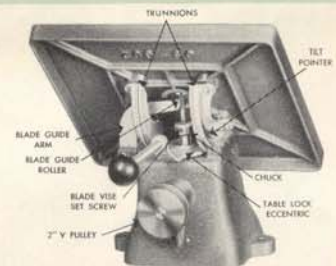

## ACCESSORIES FOR JIG and SABER SAWS

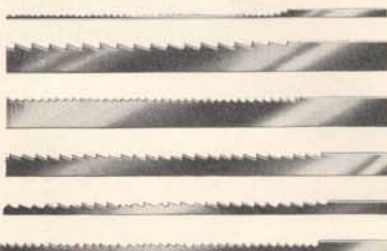

Jig Saw Blades of finest steel. Packaged 6 per package.

	Thickness	Width	Teeth Per Inch
Y-331	.020	.110	20
Y-332	.020	.110	15
Y-333	.020	.110	10
Y-334	.028	.187	10
Y-335	.028	.250	20
Y-336	.028	.250	7
Y-337	.016	.054	20
Y-3A	Package of 6 Assorted Jig Saw Blades		



Saber Saw Files (Y-730A)-12 Shapes of Files. In convenient plastic box. Fit Jig Saw or Saber Saw. Cuts on down stroke.

Sanding Drum (SD-710) for either Jig Saw or Saber Saw. Any grit may be used. For close internal sanding jobs.

Saber Saw Blades—Manufactured from finest high tempered steel.

	Thickness	Width	Teeth Per Inch
Y-721	.027	.187	7
Y-722	.027	.25	20
Y-723	.027	.187	10



Circle Cutting Attachment (CA-310). Now you can easily cut circles on your Jig Saw. The SHOPMASTER Jig Saw Circle Cutting Attachment mounts on saw quickly and will cut circles from 2" to 10" in diameter.

# SHOPMASTER DRILL PRESSES

DP-600

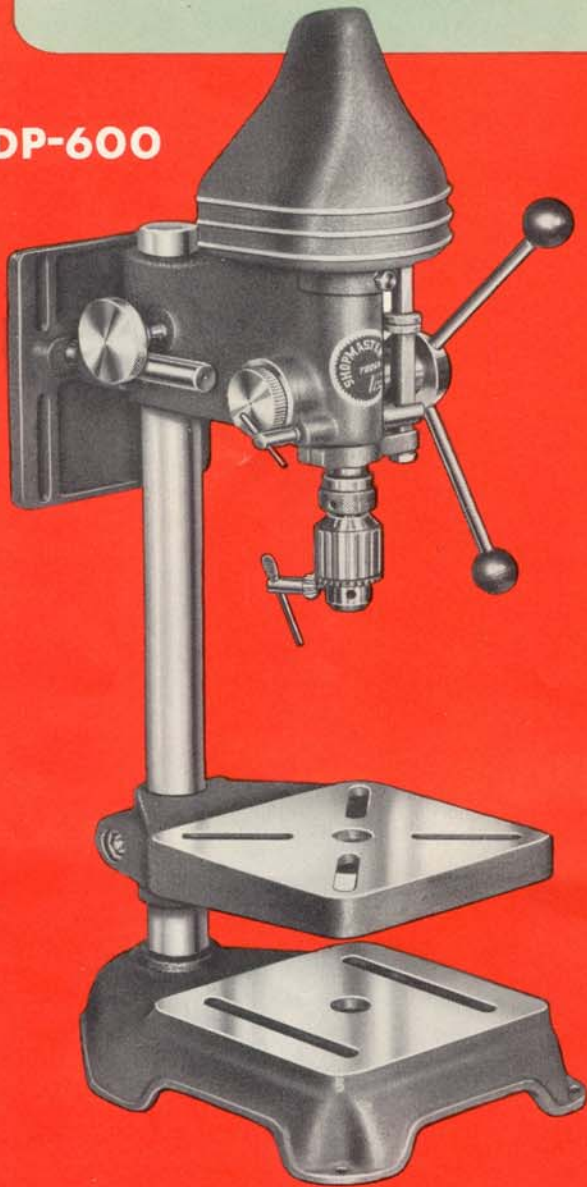

## 12" BENCH MODEL DRILL PRESS

In addition to drilling holes in wood and metal it can be converted to cut square holes for mortise joints with a mortising attachment. The Shaper Attachment with the various cutters will cut all types of mouldings and curved edges. Sanding Drum for all types of sanding. Both model Drill Presses are equipped with Jacobs Chucks, three-spoke feed wheel, centerless ground seamless steel column, ground table, and base for complete accuracy. The SHOPMASTER Drill Press is the tool that "rounds out" every shop, large or small.

### SPECIFICATIONS:

Table Size.....	7½" x 7½"
Base to Chuck.....	11 ⅝"
Table to Chuck.....	8½"
Spindle Travel.....	3"
Drive.....	6-Spline Floating Spindle
Height.....	30"
Width.....	9 ⅜"
Length.....	14½" Less Motor

### Recommendations:

Motor..... ¼ or ⅓ HP  
 Speed of  
 Chuck...700-4250 RPM  
 Shipping Weight...57 lbs.

Exceptional quality. These tools have been used in light manufacturing and have given long service. This insures years of service in the home workshop.

## 12" FLOOR MODEL DRILL PRESS

This is the same tool as the Bench Model except that it has a 64" long column to make it a Floor Model.

### Specifications in addition to Model DP-600

Height.....	64"
Base to Chuck.....	45 ⅝"
Table to Chuck.....	42½"
Shipping Weight.....	65 lbs.

The detailed photo tells the story of the master workmanship put in building these tools. Precise—rugged—detailed—attainable only in SHOPMASTER Tools.

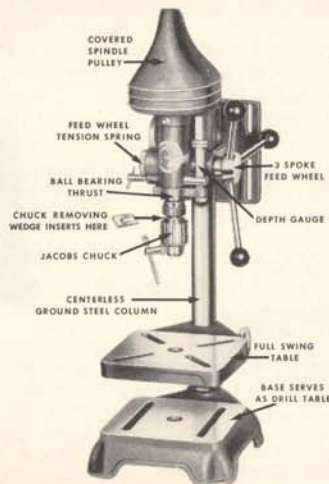

DP-600F



# VERSATILE DRILL PRESS ACCESSORIES

## Convert your Drill Press to a *Complete Workshop*



**SC-655 SHAPER COLLARS.** This set of ten collars graduated in 16ths from  $\frac{1}{8}$ " to  $1\frac{1}{16}$ " have  $\frac{1}{2}$ " centers. To be used in place of fence while cutting irregular shapes, such as table tops, etc.



**Y-635A RUBBER SANDING DISC.** This  $5\frac{1}{2}$ " Rubber Sanding Disc for Drill Press or Electric Drill can either be chucked on tool or threaded on any  $\frac{1}{2}$ "-20 Threaded Shaft. Complete with one sheet of garnet paper. Extra sheets of self-gluing paper sold two sheets glued back-to-back (Y-636A).

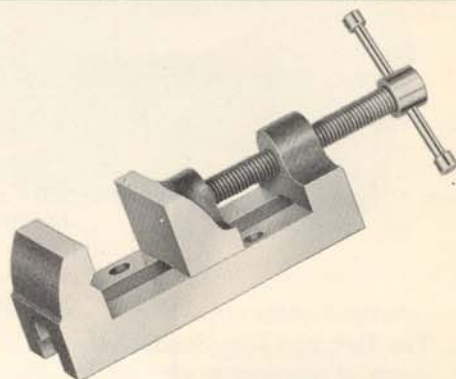

**VS-80 DRILL PRESS VISE.** Hold work securely on your Drill Press and do more accurate work. This heavy vise has accurately cut Acme thread (square thread) instead of the conventional V-thread. Vise opens three inches.

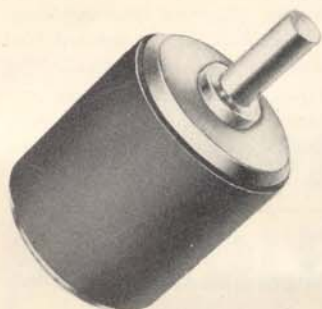

**SD-640 SANDING DRUM.** Sanding is still another job your Drill Press can do. SHOPMASTER Sanding Drum is a rubber sleeve drum that will chuck into drill press. This drum is 2" in diameter and 2" high, and complete with one sanding sleeve.

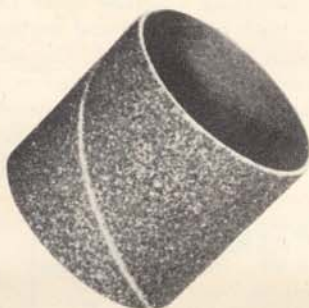

**Y-631 GARNET SLEEVES.** For SD-640 Sanding Drum. Packed six per package.



**PL-670 PLANER ATTACHMENT.** Do surfacing work on your Drill Press with this SHOPMASTER Drill Press Planer. Rotary cutter has three knives. Does smooth, accurate planing. Housing holds work to table, protects operator and deflects chips. This speedy planer will pay for itself in a short time.

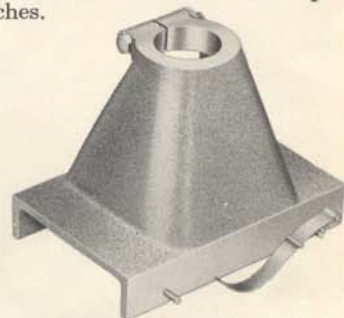

**DP-640 DRILL PRESS COLUMN COLLARS.** These collars fit under head or table of Drill Press and permit head or table to swing freely.

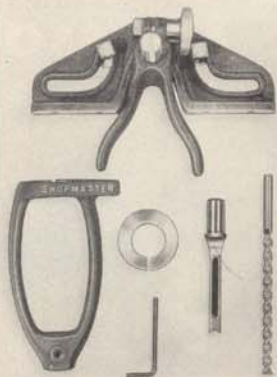

**MK-610 MORTISING KIT.** Drill square holes with your Drill Press. Kit consists of table, chisel adapter, chisel, and bit. Kit includes  $\frac{3}{8}$ " chisel and bit. However,  $\frac{1}{4}$ " or  $\frac{1}{2}$ " chisels and bits may be ordered.

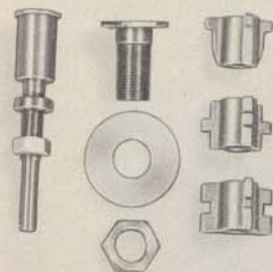

**SK-660 SHAPER KIT.** Convert your Drill Press into a Shaper. Kit contains shaper adapter, and table bearing to prevent chatter, plus three most popular cutters. Cutters are of three-wing type with  $\frac{1}{2}$ " hole. Other cutters available as illustrated.

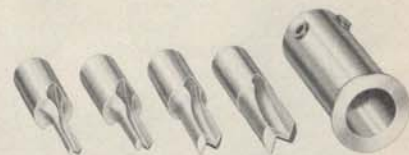

**RK-685 ROUTER KIT.** Routing and fluting can be easily done with a SHOPMASTER Router Kit. Kit contains router adapter, plus four  $\frac{1}{2}$ " shanks, double fluted router bits,  $\frac{3}{16}$ ",  $\frac{1}{4}$ ",  $\frac{3}{8}$ ",  $\frac{1}{2}$ ". Router bits or adapters can be purchased separately. Refer to price list.

FOR OTHER CUTTERS REFER TO SHAPER PAGE

# SHOPMASTER *Combination* SANDER

Your best buy is a SHOPMASTER  
Belt and Disc Sander

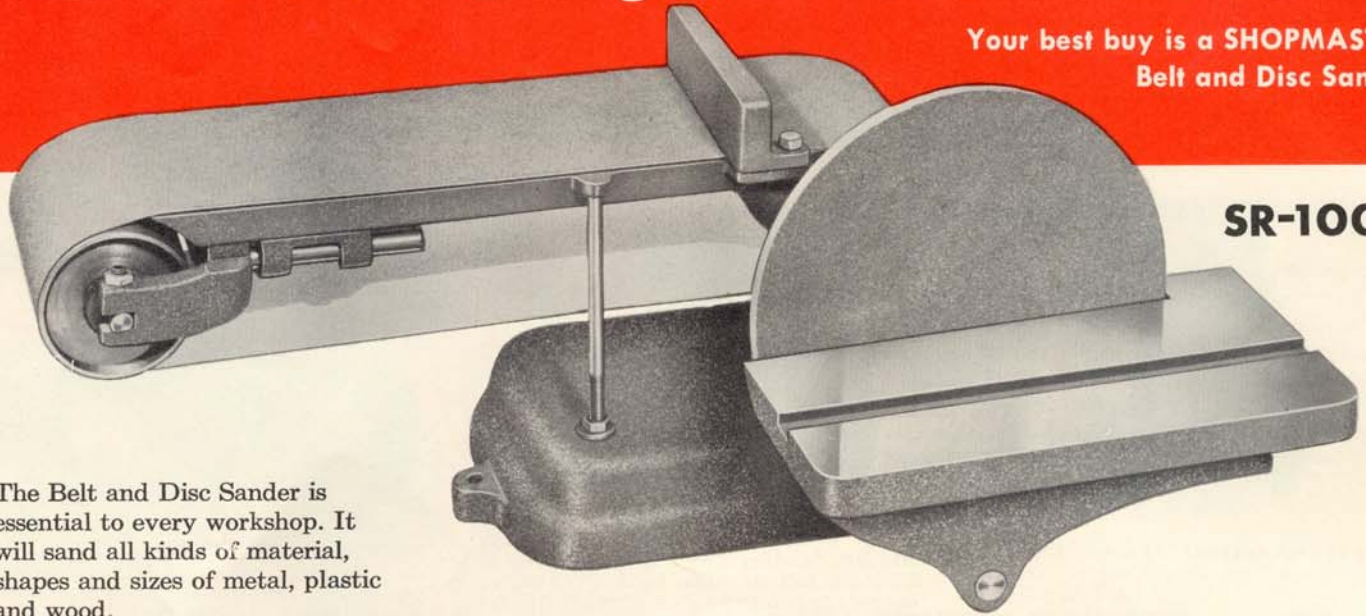

**SR-1000**

The Belt and Disc Sander is essential to every workshop. It will sand all kinds of material, shapes and sizes of metal, plastic and wood.

The SHOPMASTER Combination Belt and Disc Sander is of rugged cast construction and the usual outstanding SHOPMASTER quality. The disc is of heavy cast construction with self-lubricating Chrysler oilite bearings, insuring true running. The belt is adjustable to both horizontal and vertical positions. An important feature is the exposed cylinder end for sanding curved surfaces and odd shapes. The SHOPMASTER Belt and Disc Sander eliminates tedious hand sanding and will sand all kinds of shapes, sizes and materials—woods and plastics. The table is of heavy casting construction and tilts to 45°. The table is exchangeable from disc to belt. Every shop should have a Sander. Belt is 6"x48".

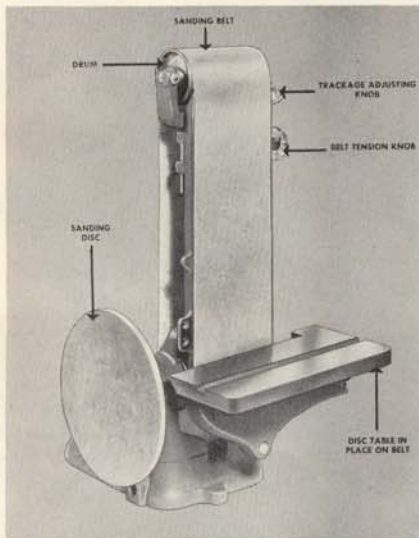

## SPECIFICATIONS:

Overall Length.....	28"
Overall Width.....	20"
Table Size.....	6"x12"
Belt Drive Pulley.....	3 3/4" Diameter
Distance Between Centers of Belt.....	18 1/4"
Belt Tension Pulley.....	3 1/2"
Belt Size.....	6"x48"
Disc Size.....	10"

## Recommendations:

Motor (1750 RPM).....	1/2 HP
Disc Speed.....	1450 RPM
Belt Speed.....	1430 ft. per Minute
Shipping Weight.....	50 lbs.

Shown are features of the Combination Belt and Disc Sander, the unit in vertical position and versatility of table. Mounted on our TS-50 Stand. The outstanding feature of the SHOPMASTER trackage adjustment knob, belt tension knob and belt tension lock.

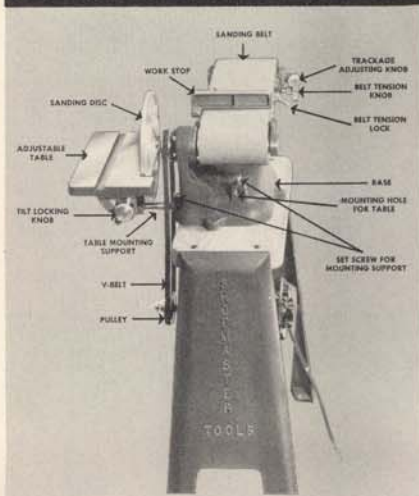

## SANDER ACCESSORIES

1. High quality Aluminum Oxide Sanding Belts.

- Y-1020 Fine Grit  
6"x48"
- Y-1021 Medium Grit  
6"x48"
- Y-1022 Coarse Grit  
6"x48"



2. SHOPMASTER Aluminum Oxide Sanding Discs, five per package.

- Y-1040 Fine Grit
- Y-1041 Medium Grit
- Y-1042 Coarse Grit



3. SF-1010 Belt Fence. Fence is adjustable to many positions and can be tilted 45°. An important accessory to your Sander. Permits accurate edging of long boards.



4. SHOPMASTER Disc Adhesive (Y-1005). Compounded to hold sanding paper securely on disc. (Sold in 1/2 pint cans.)

# SHOPMASTER 4" BELT AND DISC SANDER



**SR-5600**

## QUALITY—PRICE—SATISFACTION GUARANTEED

A low priced but excellent sander. This combination sander can sand, polish as well as buff. Ideal for home workshop. Sets in vertical position. Does curved and irregular work with end drum. Can be used on wood or metal. Has Chrysler oilite bearings. Easy belt adjustment.

### SPECIFICATIONS:

Overall Length.....16"  
 Overall Width.....10"  
 Table Size.....4 1/4" x 9 1/2"  
 Belt Drive Pulley.....3" Diameter  
 Size of Belt.....3/4"  
 Disc Size.....5"

### Recommendations:

Motor (1750 RPM). 1/3 HP  
 Motor Pulley...2 1/2" Diam.  
 Disc Speed...1450 RPM  
 Belt  
 Speed. 1430 ft. per Min.

# SHOPMASTER SPINDLE SHAPER

- Micro-adjusting fence
- Adjustable motor mount
- An outstanding tool for the money

Cut your own mouldings and edges with this SHOPMASTER Spindle Shaper. Quick adjusting and locking spindle, with two sealed-for-life ball bearings. This rugged Shaper will do all types of work and is a real production tool. Fence has a micro-adjusting screw so fences can be quickly adjusted and set. Spindle travels 1" up and down so any type cut can be made. Standard 1/2" bore, three-wing cutters are available in a variety of shapes. A Shaper in your SHOPMASTER Shop will brand your projects with the professional touch.

### SPECIFICATIONS:

Table Size.....14" x 18"  
 Overall Height.....10"  
 Overall Length.....22 1/2"  
 Overall Depth.....14"  
 Fence Length (Each Side)...10"  
 Spindle Pulley...1 1/2" Diameter  
 Spindle Travel (Up and Down). 1"  
 Spindle Diameter.....1/2"

### Recommendations:

Motor... 1/3 or 1/2 HP, 3450 RPM, 4" Pulley, 1/3 or 1/2 HP, 1750 RPM, 8" Pulley; (9000 RPM Spindle Speed)

Comes complete with micro-adjusting fence, adjustable motor mount, less motor.  
 Weight...28 lbs.

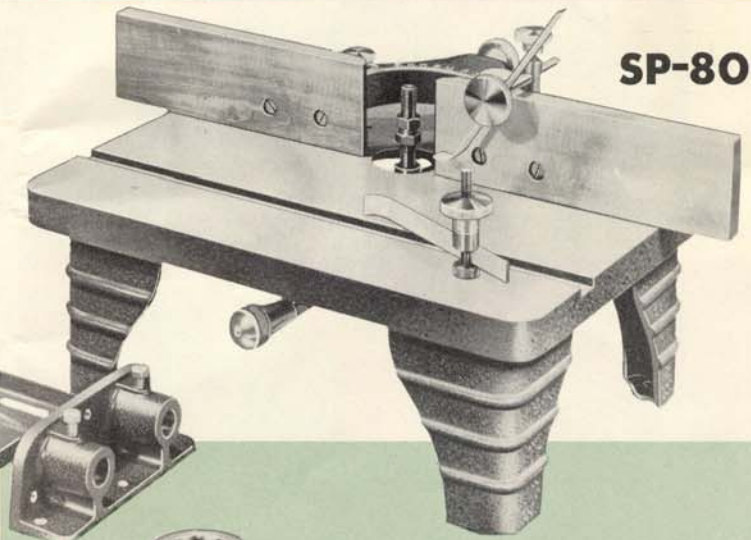

**SP-800**



### ACCESSORIES

SC-655 Shaper Collars for use on irregular shaped items. For use where it is impossible to use regular fence. Ten to a set from 3/8" to 1 1/16" graduated in 1/16" to make all depths of cuts. These collars are a must for all shaper users.

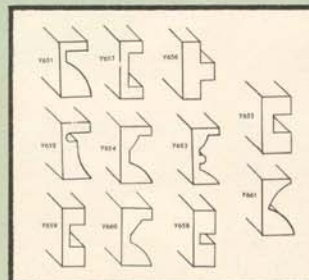

SHOPMASTER Shaper Cutters are made of finest high speed steel, precision machined and carefully ground. Nearly every type of cut can be made with these easy-to-sharpen long-life cutters. Eleven shapes of cutters available as illustrated.

Y-651, Y-652, Y-653, Y-654, Y-655, Y-656, Y-657, Y-658, Y-659, Y-660, Y-661.

# SHOPMASTER LATHE

SHOPMASTER tools give you  
long years of service



**L-500**

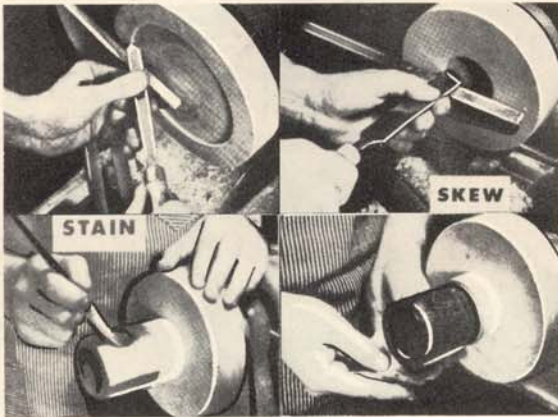

The Lathe has many uses and is easy to operate. Picture depicts some of the basic uses of the Lathe.

A tool of hundreds of uses is the SHOPMASTER Lathe (L-500). The long base (31" between centers) and large swing (10") make possible all types of turning. The headstock has two sealed-for-life ball bearings and has a four-step built-in pulley for a great variety of speeds. Both ends of headstock spindle are threaded to take the six inch face plate furnished. Centers of headstock and tailstock are No. 1 Morse Tapers, for true running, and ease of change. Tailstock is easily adjusted for any length turning (NO Wrenches are Necessary). This tool is equipped with centers, 6" face plate, V-belt, and four-step motor pulley. A Lathe is one of the most interesting tools in a woodworking shop. Buy this Lathe and complete your shop.

## SPECIFICATIONS:

Capacity.....	10" Swing, 31" Centers
Spindle (Outboard and Inboard Turning).....	$\frac{3}{4}$ "-16 Thread
Headstock.....	Sealed-for-Life Ball Bearings
Centers.....	No. 1 Morse Taper
Height.....	11 $\frac{1}{4}$ "
Width.....	7 $\frac{1}{2}$ "
Length.....	47"
Motor (Recommended).....	$\frac{1}{4}$ or $\frac{1}{3}$ HP
Lathe Speed.....	700 to 4000 RPM
Motor Pulley (Included).....	4 Step
Comes complete as illustrated, less motor.	Packaged Weight... 42 lbs.



LC-510 Screw Center. SHOPMASTER Screw Center is designed to hold small turnings. No costly screw to replace, as this center will use any No. 10 wood screw. Can be used on any Lathe with No. 1 Morse Taper Headstock.



SHOPMASTER Face Plates.  
FP-530—4" Face Plate  
L-507—6" Face Plate  
FP-531—8" Face Plate (all are threaded both right and left hand. For any  $\frac{3}{4}$ "-16 thread headstock spindle).

## LATHE ACCESSORIES



Y-511 Four-Jaw Lathe Chuck. Chuck with hardened steel jaws will hold all types of irregular items. Chuck threads on inboard end of Lathe spindle, and will fit any  $\frac{3}{4}$ " diameter 16 thread Lathe.



Y-510—No. 33 Morse Taper Arbor. Will fit headstock or tailstock on your Lathe.

Y-510A—No. 33 Morse Taper Arbor with Jacobs Chuck. Will do a variety of work, drilling, reaming, etc.



Y-520A—Professional set of 8 Lathe Tools, including  $\frac{1}{4}$ " gouge,  $\frac{1}{2}$ " gouge,  $\frac{3}{4}$ " gouge, 1" skew,  $\frac{1}{2}$ " skew, parting tool, spear point, and  $\frac{1}{2}$ " round nose with long hardwood handles and fine steel blade, carefully tempered keen cutting edge.

Y-540A—Professional set of 5 Lathe Tools.



TR-520 Double Post Tool Rest. Will Save time with long turnings. This tool rest is 14" long and has a ground face so lathe tools will work freely.

# SHOPMASTER GENERAL ACCESSORIES



**Y-5100 TOOL LIGHT.** Makes a good light for close work. Can be mounted and moved readily. Cord shaft is flexible. Vibration will not jar it loose. Fits all tools.

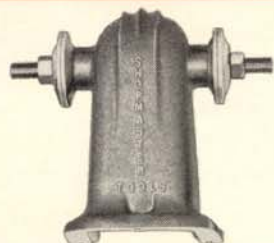

**PH-1100 POLISHING HEAD.** Polishing, grinding, buffing, sanding, sharpening, can all be done on this SHOPMASTER Polishing Head. Gives long service and makes many hard jobs easier and faster.



**DE LUXE MOTOR MOUNTS (MB-90).** Makes possible use of more than one tool with one motor. Extra clips available. Belt adjustment plate. Complete with set of clips and mounting screws. Weight 1 lb.



**MASTER MOTOR MOUNT (MB-95).** Complete with one set of clips and mounting screws.

Weight 1 lb.

**EXTRA CLIPS (MB-92A)** for Motor Mounts MB-90 and MB-95. Weight.  $\frac{1}{2}$  lb.



**TS-90 ALL PURPOSE STAND.** It's Reasonably priced. The overhanging of the motor on tilting arbors will not tip the stand. The streamlined design makes possible easy moving because of its being light weight although constructed ruggedly. Rugged construction—fits most all tools—proper height—simple adjusting—beauty of design—designed not to tip stand with motor overhanging—light weight, easy to move.



**TS-99 ALL PURPOSE DUAL STAND.** The Dual Stand has been designed for mounting more than one tool with one motor. The 8 inch Tilting Arbor and 4 inch Jointer, controlled with one motor, are shown as example. Stand includes Jack Shaft Y2010A, making possible mounting of other combinations of individual tools with one motor, such as band saw, sander, etc. This compact arrangement is a saving in space, and price of motors.



**Y-98 SAWDUST BAG.** This sawdust bag collector makes it possible to collect most sawdust and chips into the bag. Fits all other tools by purely adjusting so that motor clears and bag can be hanging to one side of the stand. Protects motor from sawdust.

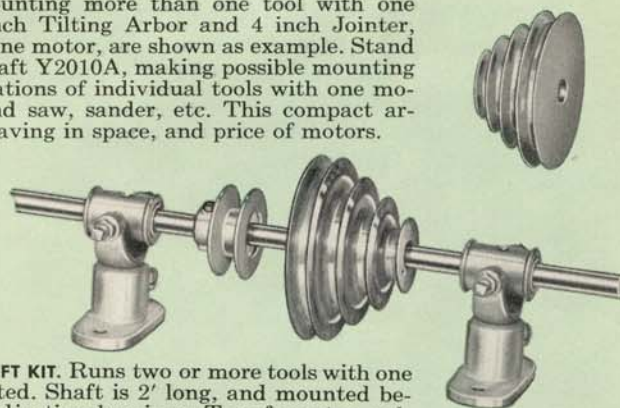

**Y-2010A JACK SHAFT KIT.** Runs two or more tools with one motor as illustrated. Shaft is 2' long, and mounted between two self adjusting bearings. Two four-step pulleys are included to give a wide range of speeds, plus a 2" pulley. Shafts can be coupled together.



**TS-53A DELUXE STAND.** An ideal mounting for SHOPMASTER Tools is the DeLux Model Stand. The stand is 28 $\frac{1}{4}$ " high, the proper height for best work. These stands can be bolted to the floor, or for the small shop, they are easily moved.

**TS-60 STEEL LEGS.** Do you need a larger stand or bench? The Master Model Steel Legs (TS-60) are sold in sets of four and can be assembled as you wish to any size. Legs are 27 $\frac{3}{4}$ " high with brackets for bolting to floor and also shelf brackets.

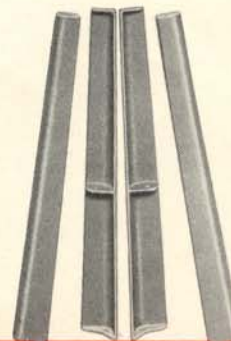

# A SHOPMASTER SHOP

in your home IS THE KEY TO BETTER LIVING



**PICTURED IS A DELUXE SHOP** including all individual tools with individually mounted motors. The photo above illustrates how this can be done. With the Deluxe shop there is no project that can't be finished with professional results after a limited amount of experience with your tools.

Pictured at the right—an example of the beginner's shop, or where limited space is available. The mounting of more than one tool and one motor on a movable stand. SHOPMASTER tools because of their light weight, rugged construction insure mobility which is important in limited space.

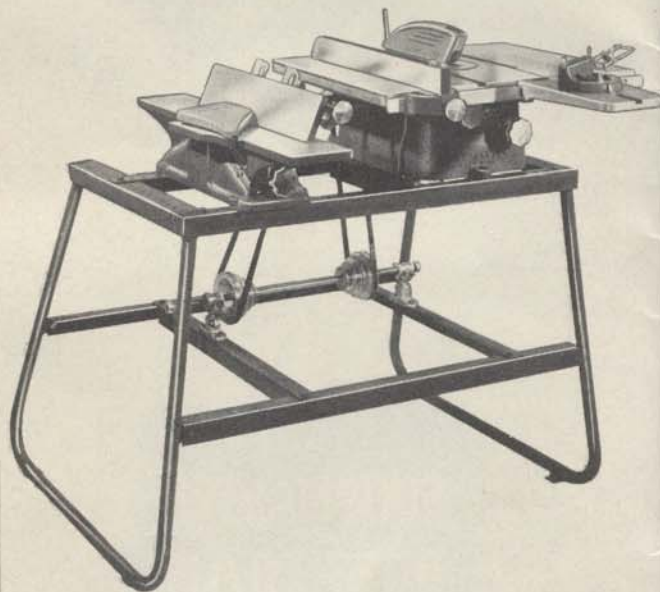

Here pictured, is a complete shop with one tool, SHOPMASTER's Combination Universal Tool. Ideal where space is at a minimum . . . and suitable for the individual who desires the combination type shop. This SHOPMASTER spectacular new Combination tool is a whole shop designed in one tool.

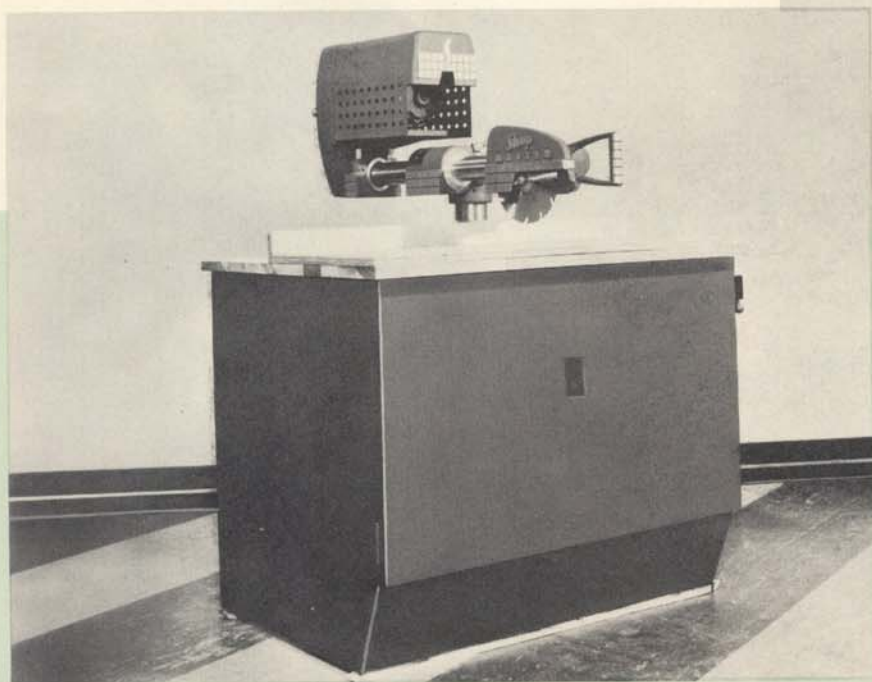

# BOOKS and PLANS that are available for the woodworker

We are listing plans and books that are available to the home workshop enthusiast. You can secure plans on how to build a house, how to build a toy, furniture, jig saw patterns, just about anything or any type project you wish to approach.



PLANS AVAILABLE AT SHOPMASTER DEALERS

## LIST OF SHOPMASTER PLANS

- |                            |                                   |
|----------------------------|-----------------------------------|
| No. 51 Nut Bowl and Mallet | No. 65 Pipes                      |
| No. 52 Roller Toy          | No. 66 Lamp                       |
| No. 53 Child's Wagon       | No. 67 Picket Fence               |
| No. 54 Coaster Set         | No. 68 Coffee Table (five in one) |
| No. 55 Roller Duck         | No. 69 Lawn Chair                 |
| No. 56 Broom Holder        | No. 70 Coffee Table               |
| No. 57 Doggie Tie Rack     | No. 71 Picnic Table               |
| No. 58 Bouncing Dog        | No. 72 Silver Chest               |
| No. 59 Train               | No. 73 Baby's Crib                |
| No. 60 Gun Rack            | No. 74 Child's Chair and Table    |
| No. 62 Bird House          | No. 75 Play Pen                   |
| No. 63 Hobby Horse         | No. 76 Decoy                      |
| No. 64 Kiddie Car          | No. 77 Work Bench                 |

Plan concerns recommended by SHOPMASTER where hundreds of projects are available. Kindly write directly to these people or see their dealers.

U-Bild Enterprises, 15155 Satcoy Street, Van Nuys, California  
Plans for 25c to \$1

Popular Mechanics, 200 East Ontario Street, Chicago, Illinois  
Plans for 25c and up

The Home Craftsman, 115 Worth Street, New York, New York

Popular Science, 353 Fourth Avenue, New York 10, New York

Easi-Bild Patern Company, Pleasantville, N. Y.

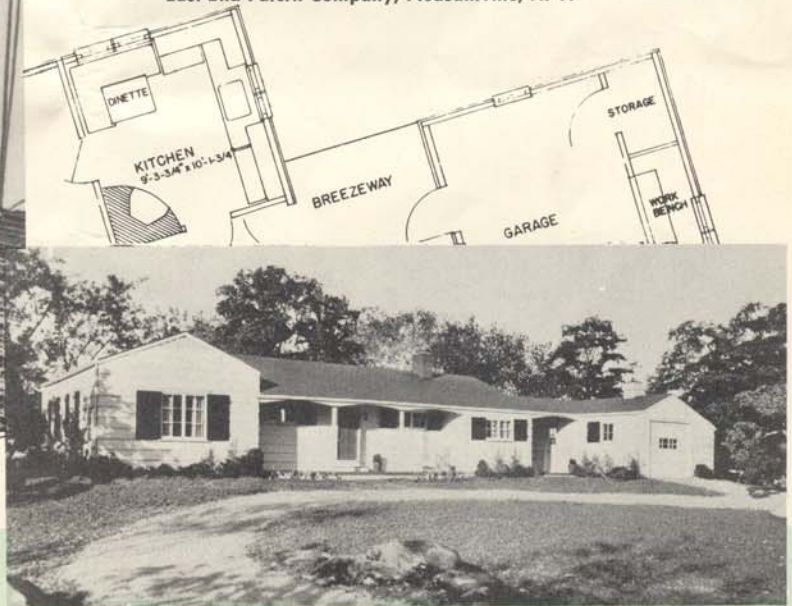

## BOOKS AVAILABLE ON THE OPERATION OF POWER TOOLS AND THE PUBLISHERS FROM WHOM THEY ARE OBTAINABLE

- HOW TO OPERATE YOUR POWER TOOLS**  
The Home Craftsman, Dept. 5, 115 Worth St., New York, New York
- POWER TOOLS AND HOW TO USE THEM**  
Popular Mechanics, 200 East Ontario St., Chicago, Illinois
- WOODWORKING FOR EVERYBODY** by Shea & Wenger  
International Textbook Company, Scranton, Pennsylvania
- OPERATION OF COMMON WOODWORKING MACHINES**  
by H. Hjorth, M. S.  
The Bruce Publishing Company, Milwaukee, Wisconsin

- THINGS TO MAKE & HOW TO MAKE THEM, Vol. 1**  
by Wm. W. Klenke—The Manual Arts Press, Peoria, Illinois
- PRINCIPLES OF WOODWORKING** by H. Hjorth, M. S.  
The Bruce Publishing Company, Milwaukee, Wisconsin
- WOOD FINISHING & PAINTING MADE EASY** by Ralph G. Waring  
The Bruce Publishing Company, Milwaukee, Wisconsin
- A COURSE IN WOOD TURNING** by Milton & Wohlers  
The Bruce Publishing Company, Milwaukee, Wisconsin
- AMATEUR POWER WORKING TOOLS** by A. Frederick Collins  
J. B. Lippincott Company



**"SHOW IT WITH PRIDE...  
YOU MADE IT YOURSELF"**

**SHOPMASTER**



# SHOPMASTER

HOME WORKSHOP AND PROFESSIONAL TOOLS

EFFECTIVE DATE — JANUARY 1, 1953

## PRICE LIST

COVER 8" TILTING ARBOR SAW (TA-900) (Page 1)

**Page 2. TILTING ARBOR AND TABLE SAWS**

*Shopmaster Table Saws are Outstanding because of their Durability and Rugged Construction.*

TA-1200M 10" DELUXE TILTING ARBOR SAW complete with Saw Guard, TE-1211 Table Extensions, Mitre Gauge, Stop Rods, Long Double Locking Rip Fence, Combination Blade. Shipping Weight, 95 lbs. **102.00**

**Page 3.**

TA-900 8" MASTER MODEL TILTING ARBOR SAW complete with Mitre Gauge, Stop Rods, Rip Fence, Saw Guard, Combination Blade. Shipping Weight, 73 lbs. **79.95**

**Page 4.**

TA-5800 8" TILTING ARBOR SAW complete with Rip Fence, Mitre Gauge, Stop Rods, Saw Guard. Shipping Weight, 38 lbs. **49.95**

**Page 5.**

CS-5200 8" TILTING TABLE SAW complete with Rip Fence, Mitre Gauge, Stop Rods, Saw Guard, Combination Blade. Shipping Weight, 21 lbs. **29.95**

**Page 6. CIRCLE SAW ACCESSORIES**

Y-126	8" Combination Blade	2.45	Y-207	Bead Cutter	2.50
Y-127	8" Crosscut Blade	2.45	Y-208	Panel Strip Cutter	2.50
Y-128	8" Rip Saw Blade	2.45	Y-209	Glass Top Cutter	2.50
Y-129	8" Hollowground Combination Blade	4.45	Y-210	45° Flute Cutter	2.50
Y-1226	10" Combination Blade	3.95	Y-211	Tongue Cutter	2.50
Y-1227	10" Crosscut Blade	3.95	Y-212	Groove Cutter	2.50
Y-1228	10" Rip Saw Blade	3.95	Y-133	8" Sanding Disc	2.75
Y-1229	10" Hollowground Combination Blade	8.75	TA-938	Table Insert	1.25
Y-1325	7" Combination Blade	2.25	TA-1245	Table Insert	1.25
Y-132	8-Tooth, 8" Carbide-Tipped Blade	10.50	TA-1355	Table Insert	1.25
Y-136	"A" Dado Set	8.95	TA-946A	Stop Rod Assembly	1.75
Y-137	"B" Dado Set	10.95	TE-1211	Web Table Extensions for TA-1200 and TA-900	14.95
Y-135	Dado Set for 7" Saw	7.45	TE-5811	Web Table Extensions for TA-5800 and CS-5200	12.95
Y-200	Moulding Head for Circle Saw	6.25	FE-1210	Front Table Extensions	4.45
Y-201	Cove Cutter	2.50	TE-110	Table Extensions for CS-100 saw	6.95
Y-202	Crown Mould Cutter	2.50	TE-910	Table Extensions for TA-900 saw	8.95
Y-203	½" Radius Bead and 45° Cutter	2.50	TE-1310	Table Extensions for TA-5800 and CS-5200	5.95
Y-204	Glue Joint	2.50	TA-1227	Double Locking Rip Fence	5.95
Y-205	Bead Cutter	2.50			
Y-206	Screen Mould Cutter	2.50			

8" Blades available in 5/8 or 1/2 inch arbors.

**Page 8.**

JO-400	6" BALL BEARING JOINTER-PLANER. Shipping Weight, 69 lbs.....	83.50
Y-421	Jointer Knives for 6" Jointer.....	4.95

**Page 9.**

JO-1500	4" BALL BEARING JOINTER-PLANER. Shipping Weight, 28 lbs.....	49.50
Y-1521	Jointer Knives for 4" Jointer.....	3.45

**Page 10.**

SB-200	12" TILTING TABLE BAND SAW. Shipping Weight, 58 lbs.....	87.50
12" BAND SAW ACCESSORIES		
TA-1305A	Mitre Gauge—fits either 10" or 12" Band Saw.....	3.25
CA-210	Circle Cutting Attachment.....	1.50
SB-250A	Rip Fence Assembly.....	4.25
SB207-1	1/8" Band Saw Blade.....	1.50
SB207-2	1/4" Band Saw Blade.....	1.50
SB207-3	3/8" Band Saw Blade.....	1.75
SB207-4	1/2" Band Saw Blade.....	1.75

**Page 11.**

SB-1400	10" TILTING TABLE BAND SAW. Shipping Weight, 40 lbs.....	48.95
10" BAND SAW ACCESSORIES		
SB1420-1	1/8" Band Saw Blade.....	1.30
SB1420-2	1/4" Band Saw Blade.....	1.30
SB1420-3	3/8" Band Saw Blade.....	1.40
SB1420-4	1/2" Band Saw Blade.....	1.40

**Pages 12 and 13.**

CU-6000	UNIVERSAL INDIVIDUAL COMBINATION POWER TOOL. A whole shop in one tool....	249.95
Price includes 8" Circle Saw, Drill Press Attachment, Belt and Disc Sander, and Stand.		

**GENERAL ACCESSORIES THAT FIT COMBINATION TOOL.**

Y-200	Moulding Head Cutter.	Y-670	3/16" Router Bit.
Y-136	"A" Dado Set.	Y-671	1/4" Router Bit.
Y-137	"B" Dado Set.	Y-672	3/8" Router Bit.
Y-126	8" Combination Blade.	Y-673	1/2" Router Bit.
Y-127	8" Crosscut Blade.	FP-530	4" Lathe Face Plate.
Y-128	8" Rip Saw Blade.	L-507	6" Lathe Face Plate
Y-129	8" Hollowground Combination Blade.	FP-531	8" Lathe Face Plate.
Y-132	8-Tooth, 8" Carbide-Tipped Blade.	Y-511	Lathe Four-Jaw Chuck.
MK-610	Mortising Kit.	Y-520A	Set of 8 Professional Lathe Tools.
SK-660	Shaper Kit.	Y-540A	Set of 5 Professional Lathe Tools.
RK-685	Router Kit.	Y-1020	Fine Grit Sanding Belt.
Y-635A	Rubber Sanding Disc.	Y-1021	Medium Grit Sanding Belt.
PL-670	Planing Attachment.	Y-1022	Coarse Grit Sanding Belt.
VS-80	Drill Press Vise.	Y-1040	Fine Grit Sanding Disc.
SD-640	Drill Press Sanding Drum and Sleeve.	Y-1041	Medium Grit Sanding Disc.
Y-631	Garnet Sleeves.	Y-1042	Coarse Grit Sanding Disc.
		Y-1005	Disc Adhesive.

Other attachments such as Lathe, etc., will be available later.

**Page 14.**

JS-3000	20" TILTING TABLE JIG SAW. Shipping Weight, 22 lbs.....	29.95
---------	---	-------

**Page 15.**

SS-700	SABER SAW. Shipping Weight, 8 lbs.....					<b>17.95</b>
<b>ACCESSORIES FOR JIG AND SABER SAWS.</b>						
Y-331	Jig Saw Blades.....	Pkg.	<b>.35</b>	CA-310	Circle Cutting Attachment for Jig Saw.....	<b>1.50</b>
Y-332	Jig Saw Blades.....	Pkg.	<b>.35</b>			
Y-333	Jig Saw Blades.....	Pkg.	<b>.35</b>			
Y-334	Jig Saw Blades.....	Pkg.	<b>.50</b>	Y-721	Saber Saw Blades.....	<b>.55</b>
Y-335	Jig Saw Blades.....	Pkg.	<b>.50</b>	Y-722	Saber Saw Blades.....	<b>.55</b>
Y-336	Jig Saw Blades.....	Pkg.	<b>.50</b>	Y-723	Saber Saw Blades.....	<b>.55</b>
Y-337	Jig Saw Blades.....	Pkg.	<b>.35</b>			
Y-3A	Package of 6 assorted Jig Saw Blades.....	Pkg.	<b>.55</b>	Y-730A	Saber Saw Files (Set of 12)...	<b>12.50</b>
				SD-710	Sanding Drum.....	<b>1.50</b>

**Page 16.**

DP-600	12" BENCH MODEL DRILL PRESS. Shipping Weight, 57 lbs.....	<b>48.95</b>
DP-600F	12" FLOOR MODEL DRILL PRESS. Shipping Weight, 65 lbs.....	<b>54.00</b>

**Page 17.****DRILL PRESS ACCESSORIES**

SC-655	Shaper Collars.....		<b>3.50</b>
Y-636	Sanding Discs (Pkg. of 5).....	Pkg.	<b>.40</b>
Y-635A	Rubber Sanding Disc.....		<b>2.25</b>
VS-80	Vise.....		<b>5.95</b>
SD-640	Sanding Drum.....		<b>1.95</b>
Y-631	Garnet Sleeves.....	Pkg. 6	<b>1.00</b>
PL-670	Planing Attachment.....		<b>9.95</b>
DP-640	Column Collars.....		<b>1.50</b>
MK-610	Mortising Kit.....		<b>14.50</b>
SK-660	Shaper Kit.....		<b>9.75</b>
RK-685	Router Kit.....		<b>5.95</b>
Y-640A	1/4" Mortising Chisel and Bit.....		<b>5.95</b>
Y-641A	3/8" Mortising Chisel and Bit.....		<b>5.95</b>
Y-642A	1/2" Mortising Chisel and Bit.....		<b>5.95</b>
MA-620	Mortising Chisel Holder only.....		<b>3.85</b>
MG-630	Mortising Fence and Hold-down only.....		<b>4.95</b>
Y-640	1/4" Mortising Chisel.....		<b>3.55</b>
Y-641	3/8" Mortising Chisel.....		<b>3.55</b>
Y-642	1/2" Mortising Chisel.....		<b>3.55</b>
Y-643	1/4" Mortising Bit.....		<b>2.40</b>
Y-644	3/8" Mortising Bit.....		<b>2.40</b>
Y-645	1/2" Mortising Bit.....		<b>2.40</b>

**Page 18.**

SR-1000	6" COMBINATION SANDER. Shipping Weight, 50 lbs.....	<b>52.50</b>
<b>SANDER ACCESSORIES</b>		
Y-1020	Fine Grit Sanding Belt.....	<b>1.75</b>
Y-1021	Medium Grit Sanding Belt.....	<b>1.75</b>
Y-1022	Coarse Grit Sanding Belt.....	<b>1.75</b>
Y-1040	Fine Grit Sanding Disc.....	<b>1.50</b>
Y-1041	Medium Grit Sanding Disc.....	<b>1.50</b>
Y-1042	Coarse Grit Sanding Disc.....	<b>1.50</b>
SF-1010	Belt Fence.....	<b>8.95</b>
Y-1005	Disc Adhesive.....	<b>.90</b>

**Page 19.**

SR-5600	4" BELT AND DISC SANDER. Shipping Weight, 15 lbs.					<b>18.50</b>
<b>ACCESSORIES</b>						
Y-5630	Fine Grit Sanding Belt					<b>1.00</b>
Y-5631	Medium Grit Sanding Belt					<b>1.00</b>
Y-5632	Coarse Grit Sanding Belt					<b>1.00</b>
Y-636	Medium Grit Sanding Disc				Pkg. 5	<b>.40</b>
SP-800	SPINDLE SHAPER. Shipping Weight, 28 lbs.					<b>52.50</b>
<b>ACCESSORIES</b>						
SC-655	Shaper Collars	<b>3.50</b>	Y-656	Shaper Cutter		<b>2.50</b>
Y-651	Shaper Cutter	<b>2.50</b>	Y-657	Shaper Cutter		<b>2.50</b>
Y-652	Shaper Cutter	<b>2.50</b>	Y-658	Shaper Cutter		<b>2.50</b>
Y-653	Shaper Cutter	<b>2.50</b>	Y-659	Shaper Cutter		<b>2.50</b>
Y-654	Shaper Cutter	<b>2.50</b>	Y-660	Shaper Cutter		<b>2.50</b>
Y-655	Shaper Cutter	<b>2.50</b>	Y-661	Shaper Cutter		<b>2.50</b>

**Page 20.**

L-500	10" BALL BEARING WOOD LATHE. Shipping Weight, 42 lbs.					<b>49.95</b>
<b>ACCESSORIES</b>						
LC-510	Screw Center					<b>1.50</b>
Y-511	Four-Jaw Chuck					<b>9.95</b>
FP-530	4" Face Plate					<b>2.75</b>
L-507	6" Face Plate					<b>3.00</b>
FP-531	8" Face Plate					<b>4.00</b>
Y-510	#33 Morse Taper Arbor					<b>1.50</b>
Y-510A	#33 Morse Taper Arbor with Jacobs Chuck					<b>9.00</b>
Y-520A	Set of 8 Professional Lathe Tools					<b>14.50</b>
Y-540A	Set of 5 Professional Lathe Tools					<b>7.95</b>
TR-520	Double Post Tool Rest					<b>5.95</b>

**Page 21.**

**GENERAL ACCESSORIES**

Y-5100	Tool Light					<b>5.25</b>
PH-1100	Polishing Head					<b>3.95</b>
MB-90	Deluxe Motor Mount					<b>1.98</b>
MB-95	Master Motor Mount					<b>1.00</b>
MB-92A	Extra Clips					<b>.50</b>
TS-90	All Purpose Stand					<b>15.00</b>
TS-99	All Purpose Dual Stand					<b>23.95</b>
Y-98	Sawdust Bag					<b>9.95</b>
Y-2010A	Jack Shaft Kit					<b>6.95</b>
TS-53A	Deluxe Stand					<b>18.00</b>
TS-60	Steel Legs					<b>6.95</b>

**SHOPMASTER, INC.**

1214 SOUTH THIRD STREET

MINNEAPOLIS 15, MINNESOTA