

Model 50 6" Jointer

MAINTENANCE INSTRUCTIONS AND PARTS LIST

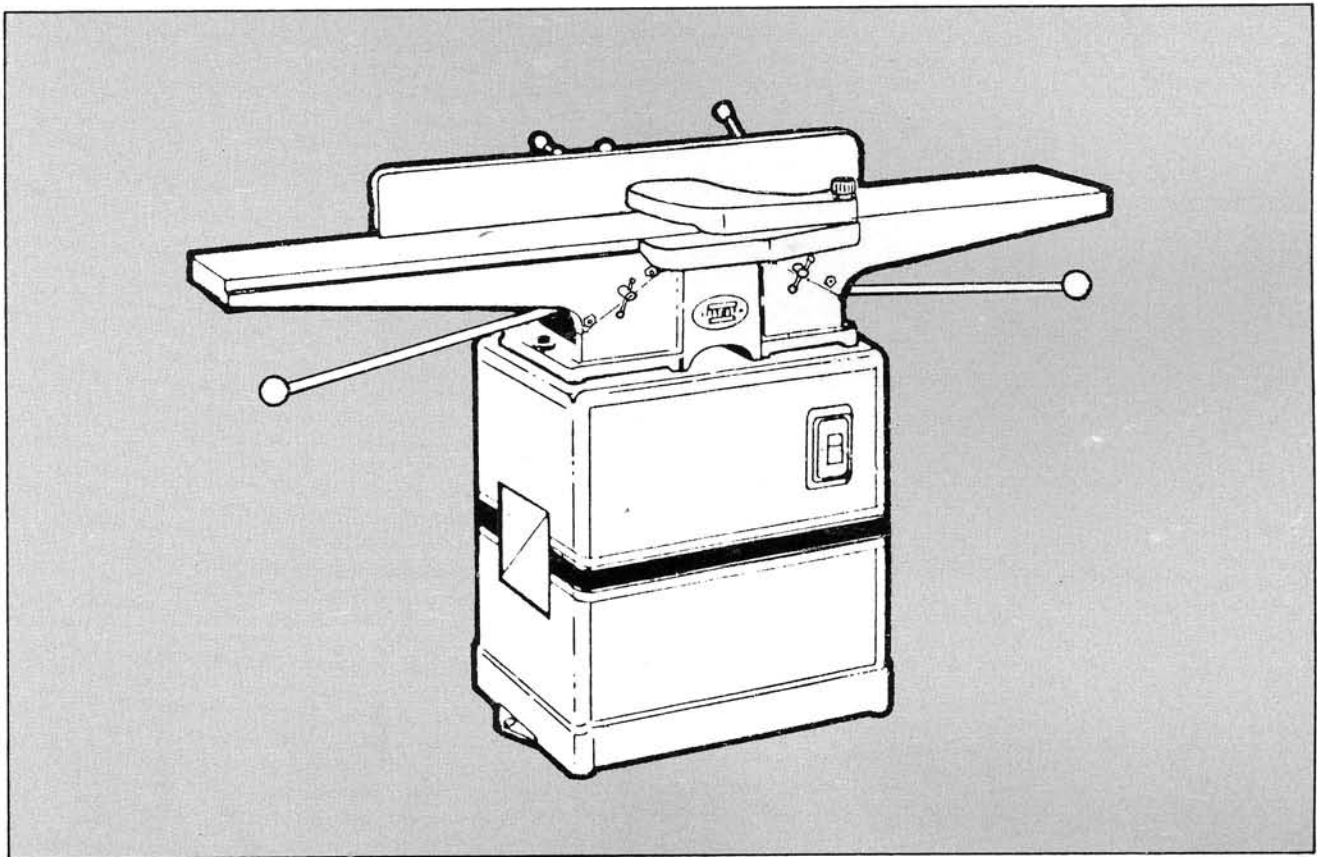

Better By Design™

POWERMATIC 

McMINNVILLE, TENNESSEE 37110 ☐ AC 615-473-5551

POWERMATIC® -  HOUDAILLE, INC.
McMinnville, Tennessee 37110
AC 615-473-5551

TABLE OF CONTENTS

FOREWORD.....	3
WARRANTY.....	4
SAFETY:	
General Rules.....	5
Specific Rules.....	6
Decal Instruction.....	7
SPECIFICATIONS: Model 50-6" Jointer.....	8
RECEIVING THE JOINTER.....	9
INSTALLATION OF JOINTER.....	9
JOINTER ADJUSTMENTS:	
Leveling Tables (Gib Adjustment).....	10
Spring Cut.....	11
Table Removal.....	11
Squaring Fence.....	11
Fence Tilt Adjustment.....	12
Guard Removal.....	13
Installing New Knives.....	13
Jointing the Knives.....	14
Depth of Cut.....	15
Cutterhead Removal.....	16
Bearing Replacement.....	16
Notes.....	17
PARTS LIST.....	18
PARTS: Exploded View.....	19
ELECTRICAL: Parts List.....	20
ELECTRICAL: Schematic.....	21
PREVENTIVE MAINTENANCE CHECK LIST.....	22

FOREWORD

This manual has been prepared for the owner and those responsible for the maintenance of a POWERMATIC Model 50-6 inch Jointer.

Its purpose, aside from machine operation, is to promote safety through the use of accepted correct operating and maintenance procedures. Read the safety and maintenance instructions thoroughly before operating or servicing the machine.

In order to obtain maximum life and efficiency from your Powermatic jointer and to aid in operating and maintaining the jointer with safety, read this manual thoroughly and follow all instructions carefully.

The specifications put forth in this manual were in effect at the time of publication. However, owing to Powermatic's policy of continuous improvement, changes to these specifications may be made at any time without obligation on the part of POWERMATIC HOUDAILLE.

The information and recommendations contained in this publication come from sources believed to be reliable and to represent the best current practice. Powermatic does not intend this manual to be a complete course of instruction on how to use this machine with safety and does not guarantee or represent that the information is absolutely correct or sufficient. In addition, it cannot be assumed that all acceptable safety measures are listed or that other additional measures are not needed under particular or exceptional circumstances or conditions.

WARRANTY

POWERMATIC WARRANTY

Powermatic-Houdaille, Inc. a Subsidiary of Houdaille Industries, Inc., McMinnville, Tennessee 37110 ("Powermatic") warrants to its authorized distributors of Powermatic products and the original purchasers for such distributors, all products manufactured by Powermatic to be free of defects in material and workmanship for a period of twelve (12) months from the date of delivery from its authorized distributors or 2000 hours of use, whichever occurs first. During said warranty period Powermatic will, at its option, repair or replace any product (or component part thereof proving defective during said period. This warranty applies only to products which are used in accordance with all instructions as to operation, maintenance and safety set forth in the catalogs, manuals, and/or instruction sets furnished by Powermatic. This warranty becomes effective only if the accompanying card is fully and properly completed and returned to Powermatic within ten (10) days from date of delivery to the original purchaser.

This warranty does not apply to items that would normally be consumed or require replacement due to normal wear (blades, lubricants, etc.); to electrical motors and components which are warranted by their manufacturer; or the costs of removal, shipment for service and reinstallation. Claims relating to electrical components must be taken to the component manufacturer's local authorized repair station for service.

This warranty is null and void if the product has been subjected to (1) misuse, abuse or improper service or storage; (2) accident, neglect, damage or other circumstances beyond Powermatic's control; (3) modifications, disassembly tampering, alterations or repairs outside of Powermatic's factory not authorized by Powermatic; or to any product not bearing its original serial number plate. This warranty does not apply to normal wear and tear, corrosion, abrasion, or repairs required due to natural causes or acts of God.

To obtain the fastest possible warranty service you must first notify in writing the authorized Powermatic distributor from whom you purchased the product specifying (1) the product by catalog number and serial number, (2) the date the product was delivered to you, (3) a description of the problem for which you seek warranty service, and (4) evidence of proof of purchase. Should circumstances prohibit you contacting the distributor then contact the Powermatic factory directly. If your claim is covered by this warranty, your Powermatic distributor will provide you with instructions as to how and where service will be provided. On simple warranty replacement or repairs, installation instructions will be provided to allow correction by customer personnel. Powermatic assumes no responsibility for products which are returned without its prior written authorization. Powermatic's obligation under this warranty shall be exclusively limited to repairing or replacing (at Powermatic's option) products which are determined by Powermatic to be defective upon delivery, F.O.B. (return freight paid by customer) Powermatic's factory, and on inspection by Powermatic. In no event shall Powermatic's liability under this warranty exceed the purchase price paid for the product.

THIS IS POWERMATIC'S SOLE WRITTEN WARRANTY. ANY AND ALL OTHER WARRANTIES WHICH MAY BE IMPLIED BY LAW, INCLUDING ANY WARRANTIES FOR MERCHANTABILITY OR FITNESS FOR A PARTICULAR PURPOSE, ARE HEREBY LIMITED TO THE DURATION OF THIS WRITTEN WARRANTY. POWERMATIC SHALL NOT BE LIABLE FOR ANY LOSS, DAMAGE, OR EXPENSES DIRECTLY OR INDIRECTLY RELATED TO THE USE OF ITS PRODUCTS OR FROM ANY OTHER CAUSE OR FOR CONSEQUENTIAL DAMAGES (INCLUDING WITHOUT LIMITATION, LOSS OF TIME, INCONVENIENCE, AND LOSS OF PRODUCTION). THE WARRANTY CONTAINED HEREIN MAY NOT BE MODIFIED AND NO OTHER WARRANTY, EXPRESS OR IMPLIED, SHALL BE MADE BY OR ON BEHALF OF POWERMATIC.

SAFETY: General Rules

READ THE MANUAL

Always read the owner's manual carefully before attempting to use the machine. Know the limitations and hazards associated with its use.

INSTALLATION

All power machines must be secured to a solid foundation. Check your machine to see it is firmly secured with anchor bolts to prevent movement or tip over.

PROTECTION

Take every precaution to protect yourself, others around you, and the machine itself, from improper use. Safety is a combination of using common sense, knowing how to use the machine, and being alert at all times when using the machine.

EYES

Always wear approved safety goggles, glasses, or a face shield when operating this machine. There are no exceptions to this rule.

DRESS CODE

Do not wear loose clothing, neckties, jewelry, or gloves that can get caught in moving parts. Confine long hair. Keep sleeves above the elbow.

PLACEMENT

Place machine so that potential kickback area is not in line with aisles, doorways, wash stations, or other work areas.

ELECTRICAL GROUNDING

Your machine must be electrically grounded. If a cord and plug are used, make certain the grounding lug connects to a suitable ground. Follow the grounding procedure indicated by the National Electric Code. Keep power tools in dry areas free from moisture.

GUARDS

Be sure machine guards are in place and in good working order. Use them at all times on operations where they can be used. If a guard must be removed for any operation, make sure it is replaced immediately following completion of that operation.

POWER OFF

Make sure the machine is either unplugged or electrically disconnected and locked out when performing maintenance or service work.

HOUSEKEEPING

Before turning on machine remove all extra equipment such as keys, wrenches, scrap, stock, and cleaning rags from the machine. Keep the area around machine clean and free of scrap material and sawdust to minimize the danger of slipping.

POWER ON

On machines equipped with a manual starter make sure the starter is in "OFF" position before connecting power to machine.

SAFETY: Specific Rules

READ THE MANUAL Read, understand, and follow the safety instructions found in this manual. Know the limitations and hazards in using the 50-6 inch jointer. One safety rule decal and two caution decals (P.7) are placed on each machine as reminders of good safety practice.

NEVER surface stock less than 12 inches long, or 3 inches wide, or 3 inches thick without a hold down push block.

3 INCH RULE When working a piece of wood on the jointer, follow the 3 inch radius rule. The hands must never be closer than 3 inches to the cutter head (Fig.1).

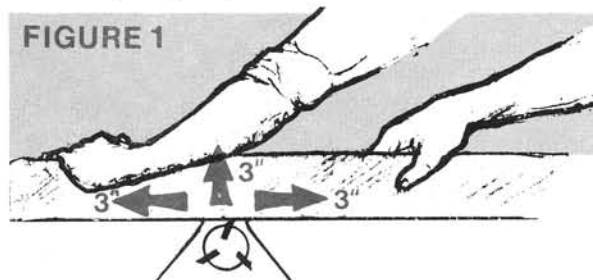

KICKBACK Use extra care in the location of the jointer in the shop. Position the jointer so that a kicked back stock will strike a wall and not endanger other persons in the area.

AVOID TIP-IN Never apply pressure to stock directly over the cutterhead. This may result in the stock tipping into the cutterhead along with the operator's fingers. Follow the 3 inch rule. Position hands away from extreme ends of stock, and push through with a smooth, even motion.

AVOID KICKBACK "Pull-out" and the danger of kicked back stock can occur when the workpiece has knots, holes, or foreign materials such as nails. It can also occur when the stock is fed against the grain on the jointer. The grain must run in the same direction you are cutting. Before attempting to joint, or plane, each workpiece must be carefully examined for stock condition and grain orientation.

NOTE: At certain times it may be necessary to plane against the grain when working with a swirly grain wood or burls. With this type work the operator must use a lesser depth of cut and a slow rate of feed (Operating Manual p.13).

HAND SAFETY It is good practice to move the hands in an alternate motion from back to front as the work continues through the cut. Never pass the hands directly over the cutter knife. As one hand approaches the knives remove it from the stock in an arc motion and place it back on the stock in a position beyond the cutterknife (Fig.2). **NOTE:** At all times hold the stock firmly.

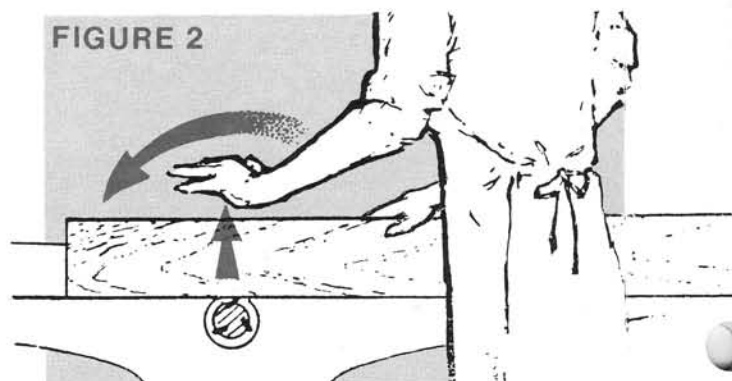

SAFETY: Decal Instruction

CAUTION

SET THE KNIVES NO MORE THAN .015 ABOVE CUTTERHEAD TO MINIMIZE THE DANGER OF KICKBACK AND POTENTIAL INJURY.

3330315

CAUTION

KEEP HANDS CLEAR OF CUTTERHEAD

3330305

FIGURE 3

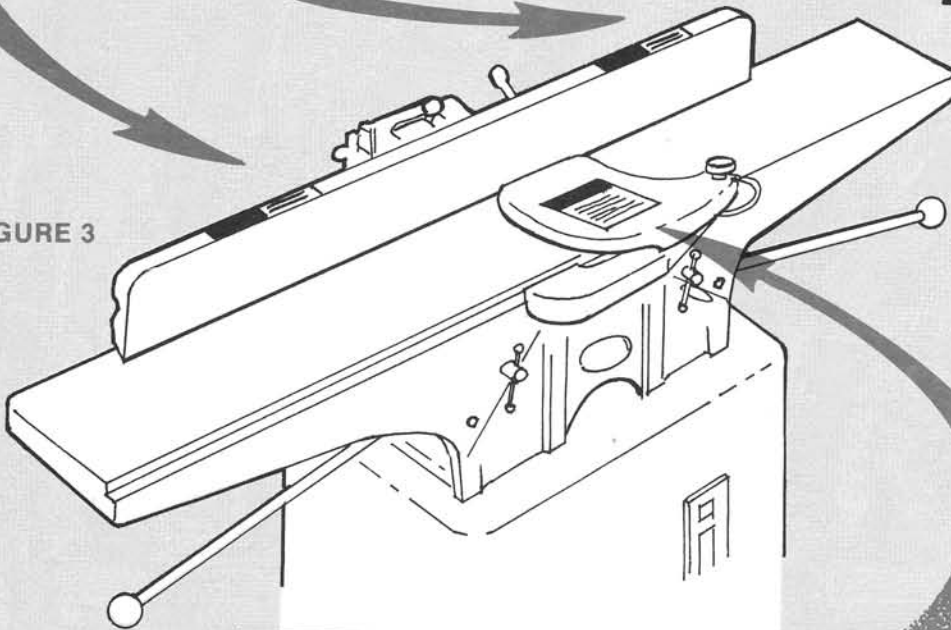

SAFETY RULES

CAREFULLY READ INSTRUCTION MANUAL BEFORE OPERATING MACHINE.
DO NOT OPERATE WITHOUT ALL GUARDS AND COVERS IN POSITION.
BE SURE MACHINE IS ELECTRICALLY GROUNDED.
REMOVE OR FASTEN LOOSE ARTICLES OF CLOTHING SUCH AS NECKTIES, ETC. CONFINE HAIR.
REMOVE JEWELRY SUCH AS FINGER RINGS, WATCHES, BRACELETS, ETC.
USE SAFETY FACE SHIELD, GOGGLES, OR GLASSES TO PROTECT EYES AND OTHER PERSONAL SAFETY EQUIPMENT AS REQUIRED.
STOP MACHINE BEFORE MAKING ADJUSTMENTS OR CLEANING CHIPS FROM WORK AREA.
KEEP THE FLOOR AROUND THE MACHINE CLEAN AND FREE FROM SCRAPS, SAWDUST, OIL OR GREASE TO MINIMIZE THE DANGER OF SLIPPING.

3330283

SPECIFICATIONS: Model 50-6" Jointer

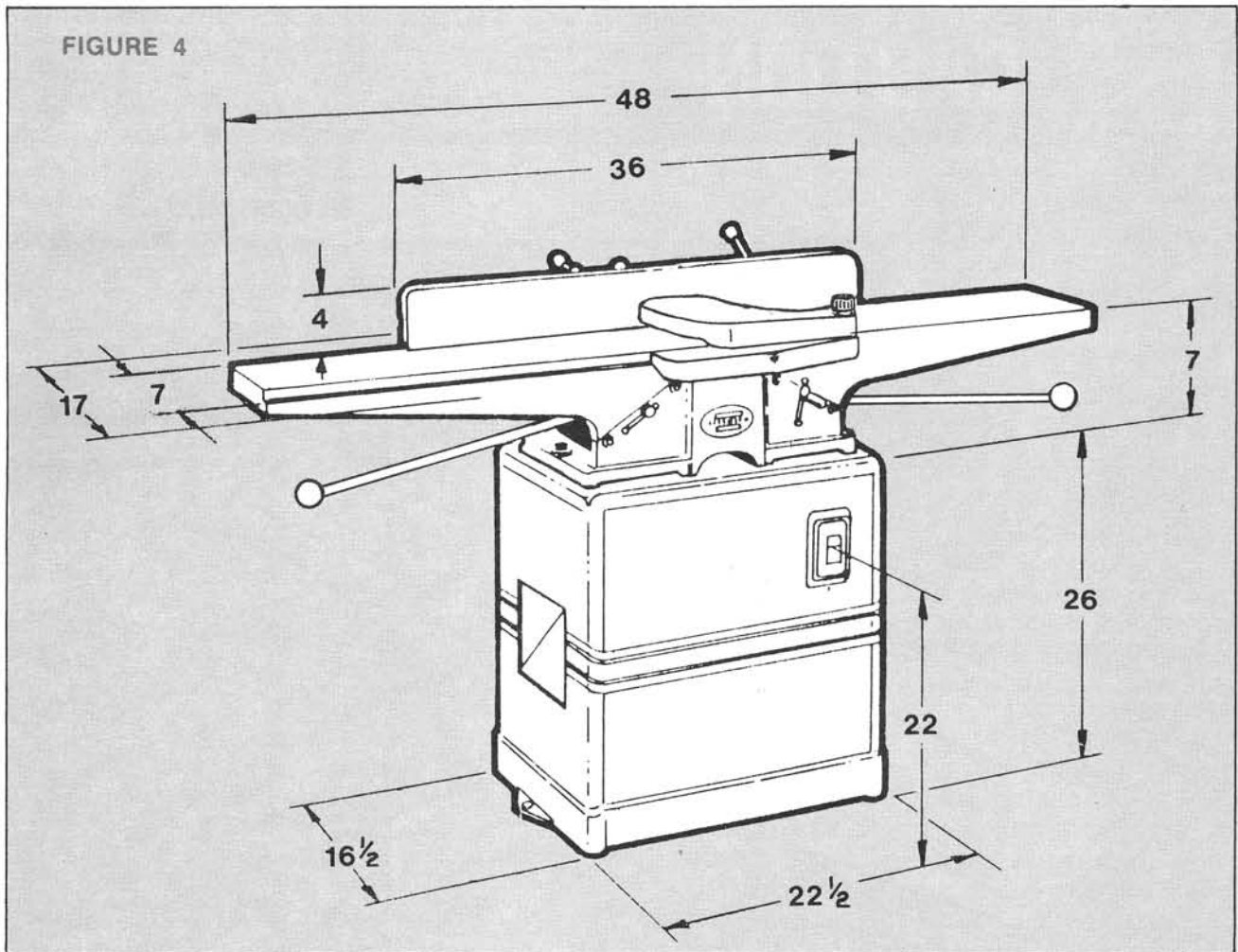

Table	7" x 48" (177.8 x 1219.2 mm)
Head cutting arc	3" (76.2 mm)
Knives (3) H.S. steel	1/8" x 3/4" x 6" (3.2 x 19 x 152.4 mm)
Speed of head (recommended)	5000 r.p.m.
Knife-cuts-per-minute	15,000
Maximum depth of cut	1/2" (12.7 mm)
Maximum rabbeting cut0" up to 1/2" x 6" (0 to 12.7 x 152.4 mm)
Fence size overall4" x 36" (101.6 x 914 mm)
Fence tilt, right or left	- 45° to + 45°
Height, less stand	14" (355.6 mm)
Height, with stand	40" (1016 mm)
Motor recommended	1/2 or 3/4 HP (.37 or .56 kw)
Weight, domestic crated, with stand & motor	290 lbs. Approx. (131 kg)
Weight, domestic crated, less stand	190 lbs. Approx. (86 kg)
Weight, domestic crated, with stand	265 lbs. (120 kg)

The above specifications, dimensions and design characteristics are subject to change without notice.

WARNING: DO NOT EQUIP OR USE THIS JOINTER WITH A MOTOR LARGER THAN 3/4 HORSEPOWER AT 3600 R.P.M. OR OPERATE THE CUTTERHEAD IN EXCESS OF 5000 R.P.M. USE OF A LARGER HORSEPOWER MOTOR OR HIGHER CUTTERHEAD SPEED VOIDS THE WARRANTY AND POWERMATIC HOLDS ITSELF HARMLESS FOR ANY INJURY WHICH MAY RESULT.

RECEIVING THE JOINTER

Remove the jointer assembly and base from their respective shipping cartons and inspect for damage. Any damage should be reported to your distributor and shipping agent immediately.

Before proceeding further, read your maintenance manual thoroughly to familiarize yourself with proper assembly, set-up, maintenance and safety procedures.

INSTALLATION OF JOINTER

Mount base to the floor with high quality anchor bolts. Bolts are attached through the mounting holes on each end of the base.

After base has been secured to a solid foundation, align the holes in the bottom of the jointer with the holes in the top of the base and secure with the three mounting bolts provided.

Attach the drive belt and adjust as shown (Fig.5,6). Using thumb and index finger, compress belt at center until it becomes taut. At this point the distance between the in-sides of the belt should be one inch. Using the adjusting slot on the motor support, raise or lower motor support base to obtain proper tension and retighten base.

FIGURE 5

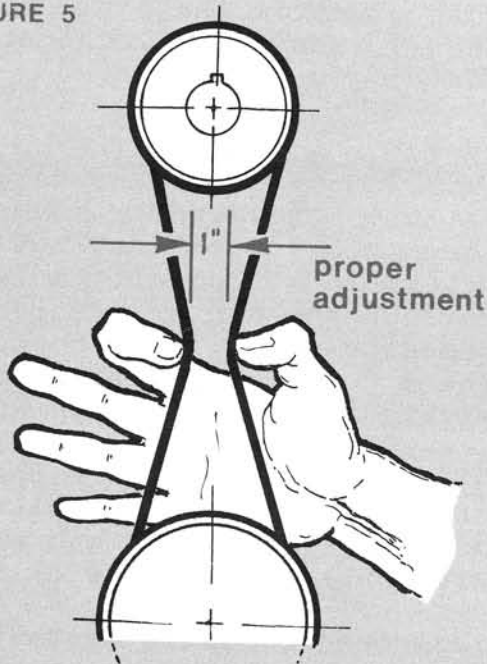
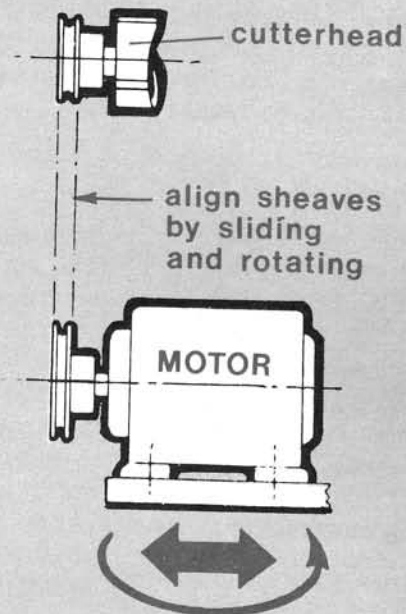

FIGURE 6



DANGER: If the machine does not come wired to run, the electricals and motor wiring must be done by a qualified

electrician. The machine must be properly grounded to help avoid electrical shock and possible death.

JOINTER ADJUSTMENTS

Check all mounting screws and set screws to see that they are locked.

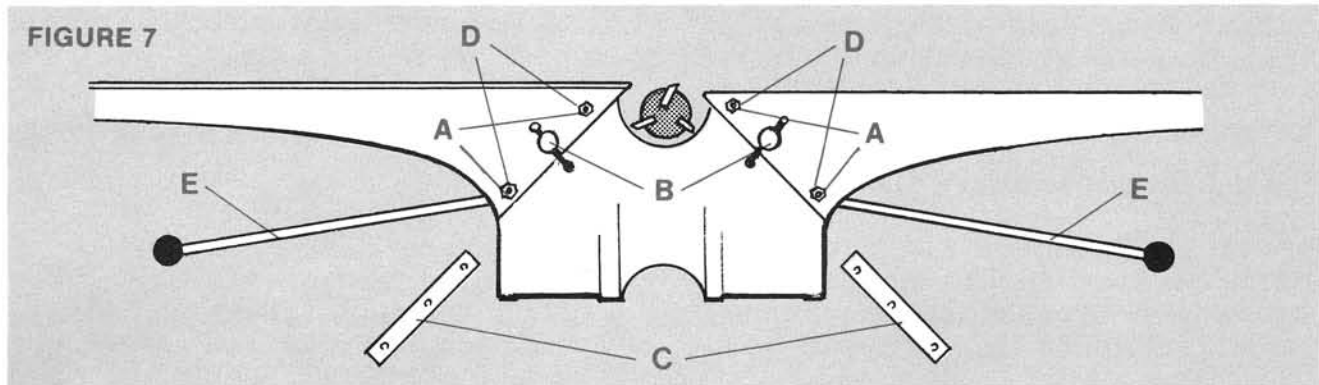

LEVELING TABLES (Gib Adjustment)

Periodically check the parallelism of the infeed and outfeed tables by placing a steel straight edge or carefully jointed wood, across the full length of both tables. Non parallelism caused by loose gibs may be corrected by the following procedure:

- 1 Loosen gibs-A and table lock handle-B (Fig.7).
- 2 Remove lower gib screw-A and check screw hole to make sure that countersink, or punch mark, in the gib is aligned with the screw hole. If countersink is not visible, or it does not line up with screw hole, use a screwdriver to lightly tap the gib back up into alignment.
- 3 Replace the lower gib screw but do not tighten.
- 4 Tighten the table lock handle-B carefully. The table will begin to move toward the straightedge.

- 5 When aligned, reset the gib screws-A until tight. If table does not align with straightedge use the adjusting arm-E until the table is flush with the straightedge.

- 6 Tighten the gib screws-A then back off approximately 1/4 turn or until the table moves freely, and reset lock nuts-D on the gib screws.

If table will not line up remove gib screws and table locking handle and remove gib. Check gib to see that set screws do not go all the way through the gib or dimple the opposite side. If either of these conditions exist replace with a new gib.

Also, check to be sure the ways are clean and free of pitch and sawdust. Lubricate gib and way with Fiske Lubriplate.

Replace gib making certain countersink, or punch mark, line up with locking screw holes. Replace gib screws.

Repeat steps 3 thru 6.

Spring Cutting

To spring cut, the outfeed table is lowered below the level of the cutterhead blade (Fig.8). Loosen both gib screws A on the outfeed table. Amount of end-drop is controlled with the table lock handle B. Tighten handle to reduce amount of drop. A 1/32 inch drop usually creates the ideal concave for spring joints. Return the outfeed table to be in line with the cutterhead knives on completion of the cut.

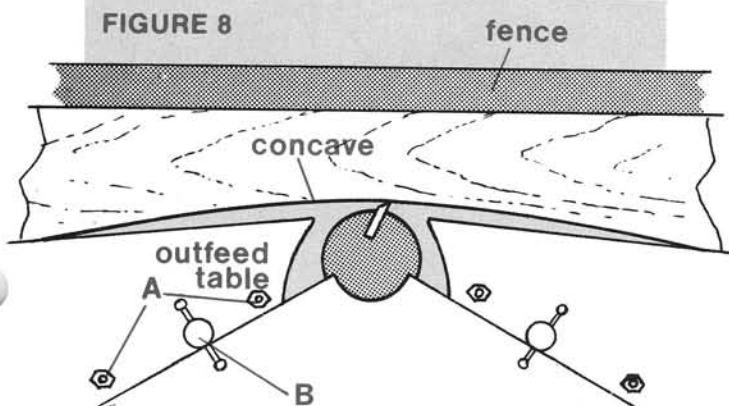

Table Removal

- 1 Unplug machine or disconnect the power from machine and lock it out.
- 2 Remove the entire fence assembly except for the support bracket.
- 3 Remove the cutterhead guard (p.13).
- 4 Lower the infeed and outfeed tables and remove cutterhead (p.16).
- 5 Remove the snap rings on both ends of the table adjustment rod A (Fig.9) and push out

- 6 Loosen the gib set screws and table lock screw (Fig.8).

CAUTION: After gib screws are loosened table could suddenly slide down.

- 7 Remove infeed or outfeed table by sliding upward.

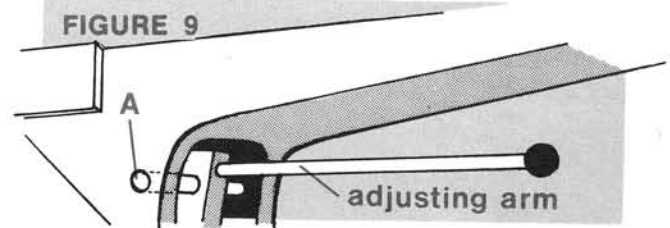

Squaring Fence

Before operating the jointer it is important to check that the fence is correctly aligned to the table. Loosen the lock nut A (Fig.10) and return the fence to the 90° position. There will be some play in the fence when

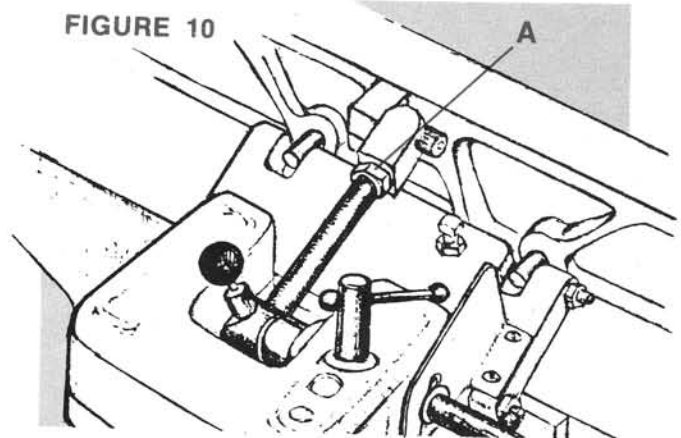

it is unlocked. All play must be removed by tilting the fence toward or away from the table while locking the lock nut. Always remove the backlash by tilting the fence in the same direction while tightening. If the fence does not come to 90° do the following procedure.

Fence Tilt Adjustment

1. Place a square on the outfeed table near cutterhead.
2. Loosen lock nut-A (Fig.11) and insert an adjusting tool in tilt rod-B .
3. Turn rod clockwise to move top of fence to the right and counterclockwise to move fence to the left.
4. When fence is square with outfeed table reset lock nut-A

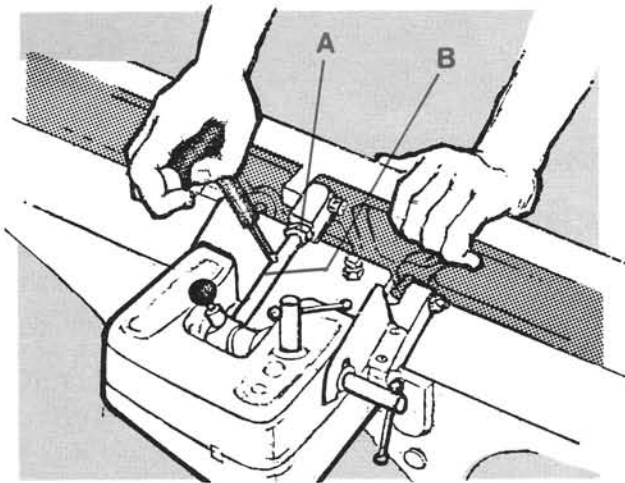

Should the fence fail to return to 90° and play is evident in the fence, remove the fence lock plunger mechanism by loosening the jam nut and inspect plunger assembly conical retainer.

If tilt rod shows signs of wear or scarring, grind the conical portion of plunger (Fig.12) until it will fully engage in the annular groove in the tilt rod. Replace plunger assembly and tighten jam nut.

FIGURE 12

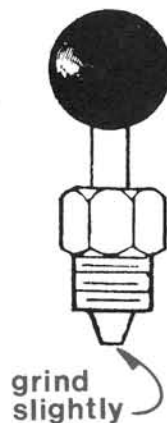

The fence may be tilted forward or backward by unlocking the fence lock screw-A and pulling out the fence lock plunger-B (Fig.13).

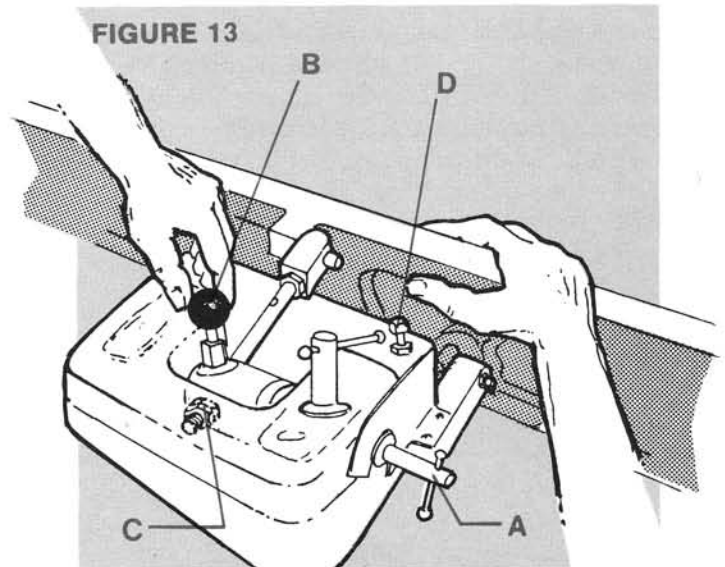

TILT FORWARD

To tilt the fence forward in the cradle-cut position loosen the fence lock screw-A . Pull up on the fence lock plunger-B and tilt the fence forward. Check the setting with a combination square. The two jam nuts-C on the end of the tilt rod are factory pre-set to stop the forward tilt at 45°. The front nut is used for adjusting and the rear nut to lock the setting. When all adjustments have been made retighten the fence lock screw-A.

TILT BACKWARD

To tilt the fence backward loosen the fence lock screw-A. Raise or lower the tilt stop screw-D. When the desired degree cut is reached retighten the fence lock screw-A.

Guard Removal

In order to remove the guard, loosen lock nut A on rabbeting ledge and loosen lock screw B (Fig.14-A). Guard assembly will lift vertically

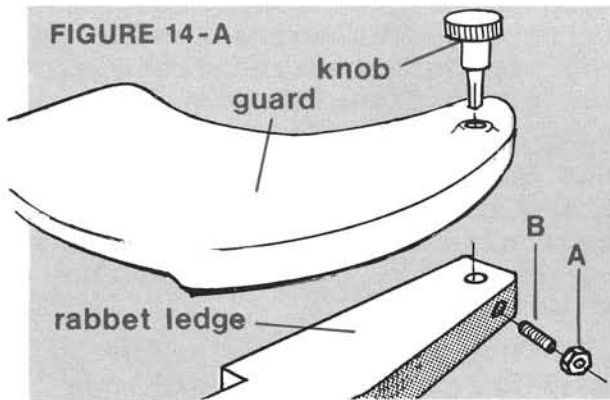

out to provide for rabbeting operations. When replacing guard it will be necessary to set guard spring tension by turning knob clockwise on top of guard to the desired tension and locking in position with the set screw. Tighten hex. lock nut to prevent the set screw from backing out. Check to see that the spring on the underside of the guard is attached with the hooked end of the spring pointing upward, as shown in Figure 14-B, to prevent dragging.

FIGURE 14-B

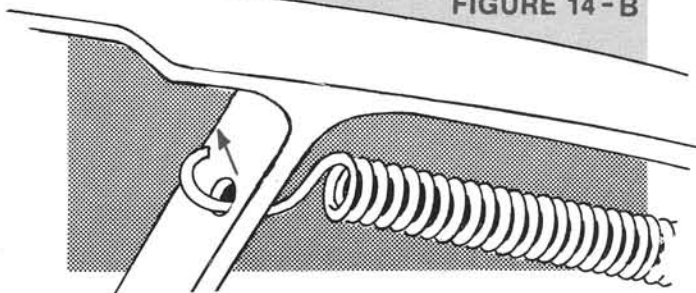

Installing New Knives

Unplug or disconnect jointer from power source and lock out power. When installing new knives remove only one knife at a time. Clean the knife slot

and install the new knife. Adjust and lock new knife in cutterhead assembly before proceeding to next knife. To remove the old knives, loosen gib locking bolts A and remove gib, knife, and jack screws (Fig.15). Using an allen wrench, turn jack screws B down one turn. Clean the jack screws, gib, knife slot, and knife thoroughly and replace jack screws.

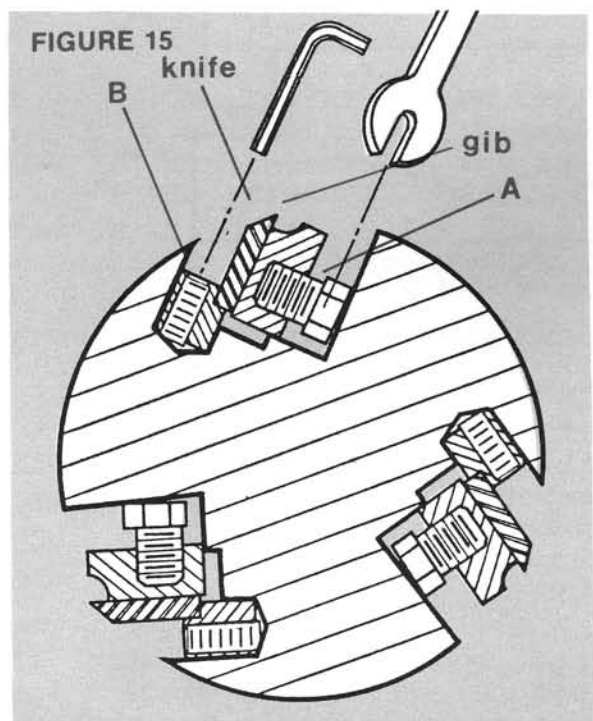

Sandwich knife and gib together and drop into knife slot. Be certain that the back of the knife is resting on the seat of the jack screw plug. Next, to position the knife for rabbeting cuts, a 1/32 inch shop scale should be placed flat on the end of the cutterhead or the rabbet slot - whichever extends the farthest. Slide the knife out until it is flush with the end of the shop scale. Set the knife locking gib 1/32 inch in from the end of the knife (Fig.16).

WARNING--Set the knives no more than .015 inches above the body of the cutterhead to minimize the hazard of kickback and severe personal injury.

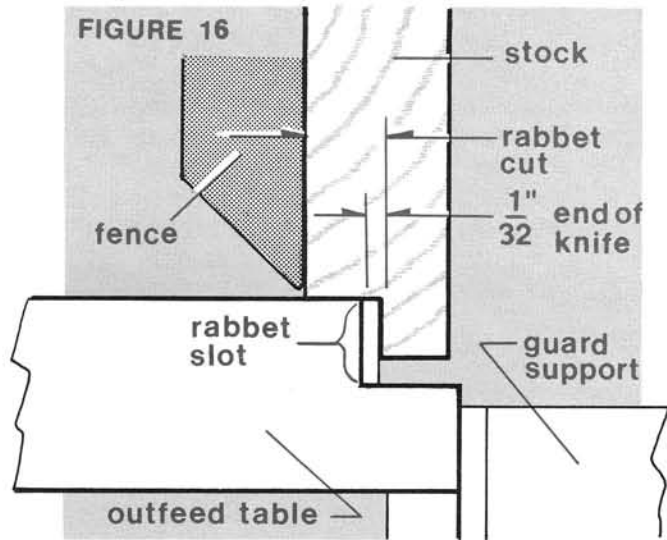

Snug the two outside gib locking screws. If you have a Model 150 knife setting gauge, place it on the outfeed table to the rear of the cutterhead with the movable platen over the cutterhead (Fig.17).

Insert an allen wrench into the jack screw, and rock the cutterhead back and forth. Watch the pointer on the 150 gauge. The pointer will begin moving downward toward "0"

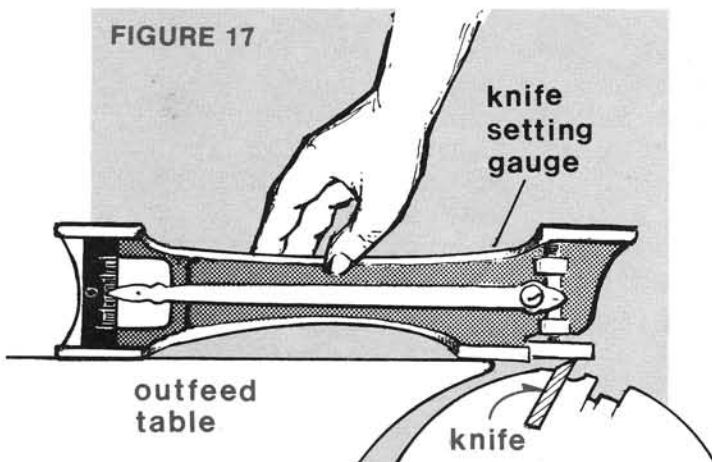

When the pointer reaches "0", it is parallel with the outfeed table. Move the gauge to the front of the cutterhead and repeat the above procedure.

This adjusting process puts the knife into the knife slot with the tip parallel and flush with the outfeed table.

Once the correct knife height has been established, secure the gib locking screws beginning with the center screw to prevent buckling or uneven knives.

If a Model 150 gauge is not available use a standard shop scale. Stand the scale on its edge on the outfeed table. The scale should extend over the cutterhead. Using the above method, raise knife until it just touches the scale at the cutterhead arc apex.

Jointing The Knives

After extended use it will be necessary to sharpen the knives on the cutterhead assembly. Before sharpening, disconnect the machine from its power source and remove the cutterguard (See "GUARD REMOVAL" p.13).

DANGER: Be sure to wear approved eye protection. Next, place a 6 inch shop scale across the infeed and outfeed tables (Fig.18).

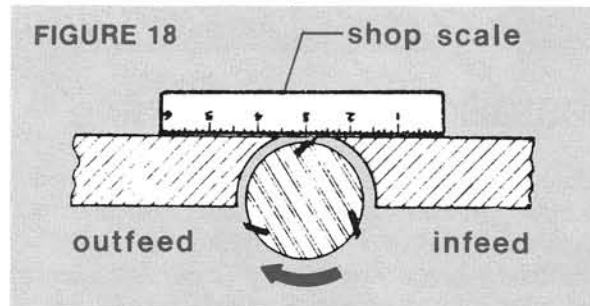

Set tables to the exact height of the high knife at the apex of the knife arc.

Clamp a block of wood across the infeed table so that the end of a sharpening stone may be placed against the wood block during the jointing operation. This will help to prevent kickback of the stone (Fig.19). Lower outfeed table .003 inches.

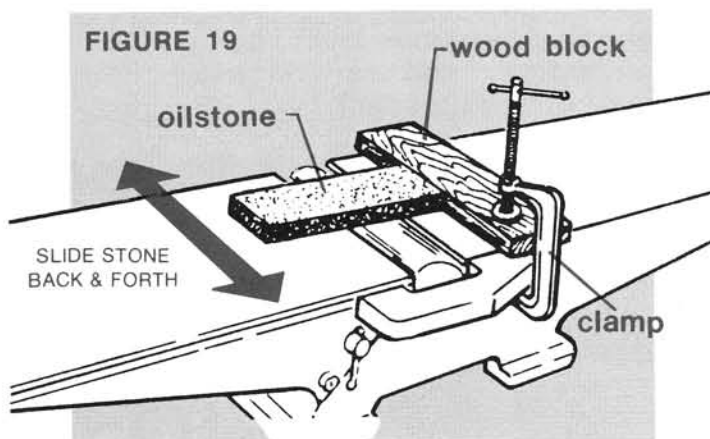

Turn machine on.

CAUTION: Keep hands clear of turning cutterhead. Place a hard 10" Arkansas oilstone over cutterhead with ends resting on infeed and outfeed tables. Slide the oil stone back and forth across the tables until knives are jointed lightly. Turn the machine off and visually inspect each knife. If only the high knife has been touched, lower the outfeed table and continue the sharpening process until every knife has been touched by the stone. After sharpening knives, place shop scales on the outfeed table.

Raise the outfeed table to the original setting parallel with the knife at the apex of the arc. Weekly sharpening will

keep knives in the proper cutting condition.

If knives are excessively worn or nicked they must be reground to a new bevel. If this is the case, follow the procedure indicated in this section "INSTALLING NEW KNIVES", page 13.

Depth Of Cut

Depth of cut is determined by the height of the infeed table relative to the cutterhead. Raise or lower the infeed table by raising the table adjustment arm located underneath the infeed table (Fig.20). Depth of cut is indicated by the depth gauge located on the side of the jointer ways. To check the accuracy of the gauge, flush the table with the cutterhead using a straight edge, and see if it reads zero depth. If it does not, readjust pointer.

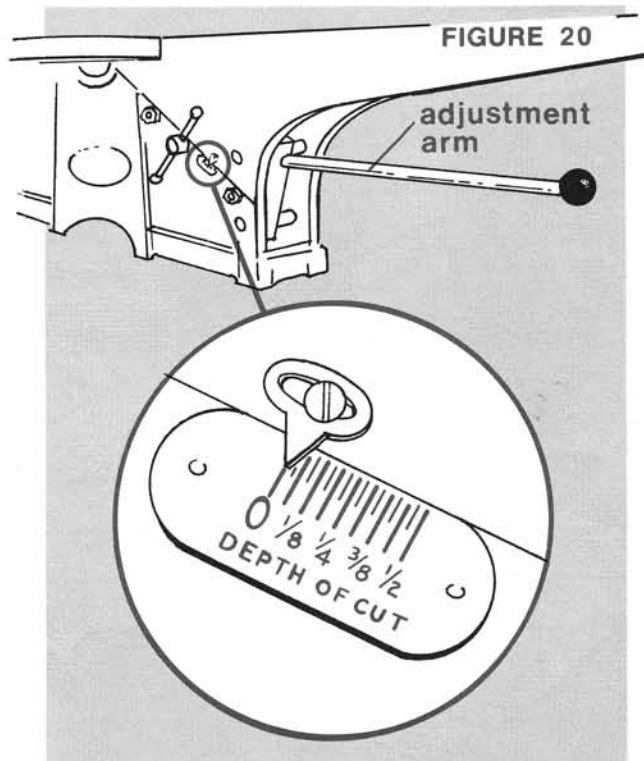

Cutterhead Removal

The following procedure is to be followed for cutterhead removal (Fig.21).

- 1 Unplug or disconnect jointer from its power source and lock it out.
- 2 Remove fence assembly and drive belt.
- 3 Loosen bearing housing retaining bolts - A , front and rear.
- 4 Lower infeed table.
- 5 Loosen the two (2) hex head screws attaching fence support, and turn stand support 90° on edge as shown.
- 6 Slide cutterhead out from rear of machine.

AFTER REASSEMBLY, INFEED TABLE WILL HAVE TO BE RELEVELLED (SEE "LEVELING TABLES", page 10).

Bearing Replacement

Before attempting any maintenance unplug or disconnect jointer from power source and lock it out.

See "Cutterhead Removal" and remove the cutterhead assembly. Remove bearing housings (Fig.22). Remove bearings with an arbor press or wheel puller.

Use fine emery cloth to remove any fine rust. Clean the cutterhead shaft and coat with oil. Press new bearing onto shaft, replace bearing housings, and re-install cutterhead assembly.

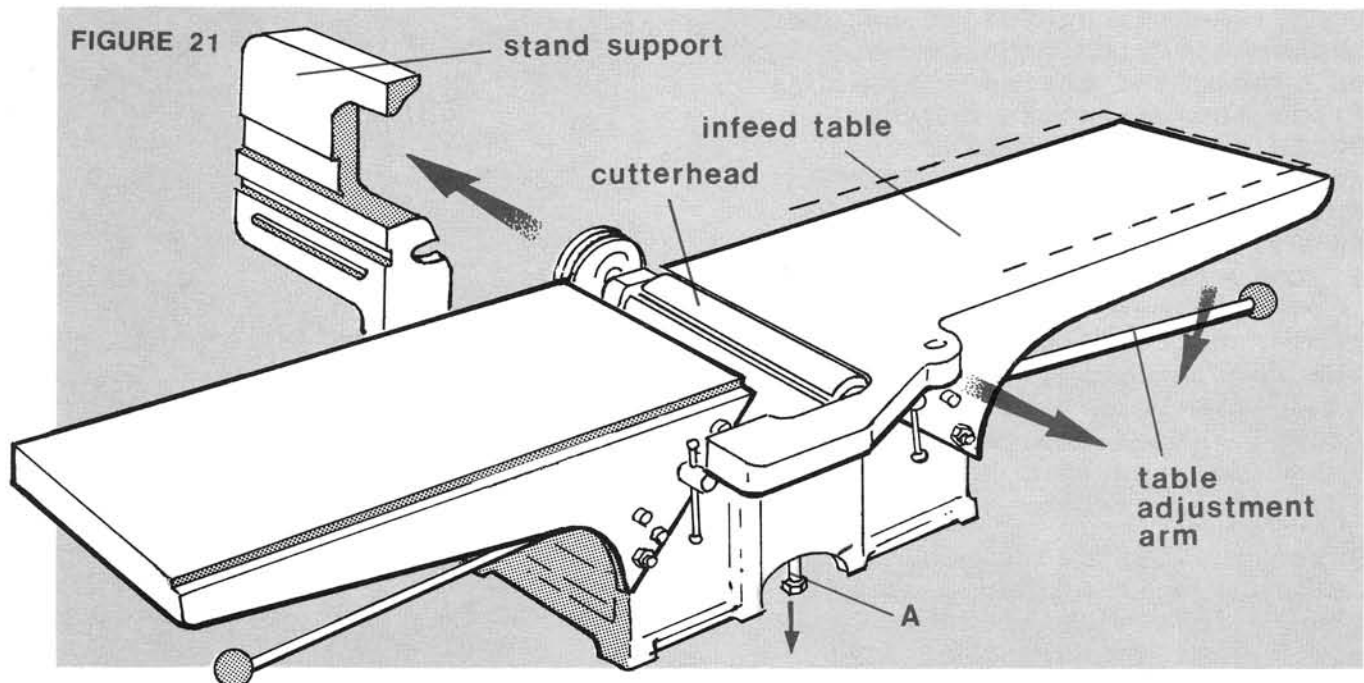
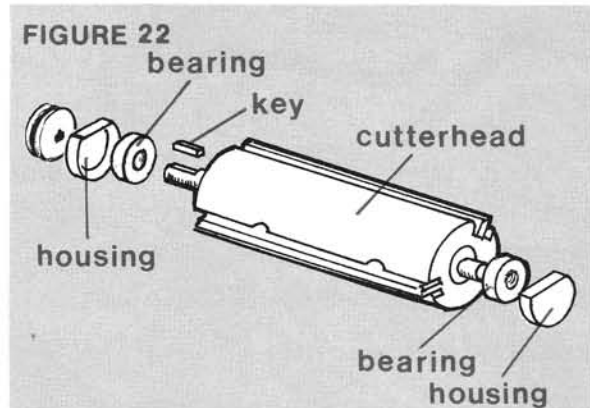

PARTS LIST: Model 50-6" Jointer

ITEM NO.	PART NO.	DESCRIPTION	QTY	ITEM NO.	PART NO.	DESCRIPTION	QTY
1	6430010	KNOB, 1 15/16 DIA. X 5/8 - 13 THD.	2	67	3583020	PIN, CUTTERHEAD	1
2	3025099	ARM, TABLE ADJUSTMENT	2	68	622005	PIN, COTTER	1
3	6715272	SCREW, HEX. HD. 5/16 - 18 NC X 2	2	69	6114013	CHAIN, SASH. # 8 X 2 3/8	1
4	6515007	NUT, JAM 5/16 - 18	3	70	6813022	SPRING EXT. #5000-389D +B 3/8 O.D. X 2 3/4 LG.	1
5	3055241	BLOCK, TABLE ADJUSTMENT	2	75	3388030	KEY 3/8 X 3/8 X 8-9/16	1
6	3670308	ROD, TABLE ADJUSTMENT	2	76	6626059	SPRING. SPS 215-156-0875 5/32 X 7/8	1
7	3670305	ROD, TABLE ADJUSTMENT	2	77	3438201	LIFTER, KNIFE CUTTERHEAD	6
8	6670008	RING, RETAINING #5100-62	4	78	6714129	SCREW SOC SET 1/4 - 20 X 3/4 NYLOC	6
9	3773314	STUD, PIVOT	1	79	3528004	LOCK-NUT FENCE SLIDE	1
11	3042200	BASE	1	80	6626038	PIN SPRING 1/4 X 1	1
12	3406016	KNOB HANDLE LOCKSCREW	2	81	3244200	GIB, CUTTERHEAD KNIFE	1
13	3268002	HANDLE, LOCKSCREW	2	82	3690065	SCREW, ADJ. SHIM	4
14	3448003	LOCK, TABLE SCREW	2	83	3250006	GUARD, BELT	1
15	6515007	NUT, JAM 5/16 - 18 STEEL PLAIN	1	84	3604004	POINTNER, TABLE DEPTH SCALE	1
16	6715153	SCREW, SOC. SET 5/16 - 18 X 1 3/8 F.P.	2	85	6706035	SCREW, R.H. MACH #6-32X 1/4 ZINC	1
20	6514001	NUT, HEX. 1/4 - 20	4	86	3684220	SCALE, TABLE HT. ADJ.	1
21	3797187	TABLE, REAR. J - 6-3	1	87	3776021	SUPPORT, FENCE	1
22	3244010	GIB, TABLE REAR	2	88	6716035	SCREW, HEX. 3/8 - 16 X 1 3/4	2
23	3797189	TABLE, FRONT J-6-2	1	89	6861301	WASHER, 3/8 FLAT	2
25	6714137	SCREW, SOC HD. SET 1/4 - 20 X 1	4	90	6861300	WASHER, LOCK 3/8	2
26	6807033	SHEAVE, HK - 34 5/8 BORE	1	91	6715017	SCREW, SOC SET 5/16 - 18 X 1	1
27	3298001	HOUSING, BEARING	2	92	6515007	NUT, HEX JAM 5/16 - 18	1
28	6060005	BEARING BALL N.D. #299503	2	93	6427001	KNIFE, CUTTERHEAD SET OF 3	1
29	3112026	CUTTERHEAD	1	94	6715045	SCREW, HEX HD. 5/16 - 18 X 2 1/2	1
31	6807027	SHEAVE, CUTTERHEAD AK - 25	1	95	6861200	WASHER, LOCK 5/16	3
32	3388004	KEY, SQ 3/16 X 3/16 X 1	1	96	6715046	SCREW, HEX HD. 5/16 - 18 X 4	2
33	3406201	KNOB, TEAR DROP	1	97	6861201	WASHER 5/16 FLAT	2
34	3670039	ROD, HANDLE	1	98	6714004	SCREW, SOC. SET. 1/4 - 20 X 1/4	1
35	3406208	KNOB, RD. 1" DIA. NYLON 1/4 - 20	1	99	6077027	BELT. 4 L-550	1
36	3601204	PLUNGER, FENCE STOP	1	100	6716035	SCREW, HEX HD. 3/8-16 X 1 3/4	3
37	3529012	OPERATING NUT, FENCE STOP PLUNGER	1	102	2759049	ASSEMBLY, JOINTER STAND	1
38	6813002	SPRING COMPRESSION	1	103	2136043	ASSEMBLY, DOOR	1
39	3670109	JS- 3 3/8 OD. X 1 1/4	1	104	3330283	PLATE, INSTRUCTION NOT SHOWN	1
40	6867006	ROD, DEGREE TILTING	1	105	3330305	PLATE, CAUTION NOT SHOWN	1
41	3064038	BRKT, TABLE STOP	1	106	3330315	PLATE, CAUTION, NOT SHOWN	1
42	6715064	SCREW, SHOULDER 5/16 - 18 X 3/4	1		2042272	BASE ASSY. ITEMS 1 TO 3, 5 TO 8, 11, 20, TO 23, 25, 57,	1
43	3092046	CLAMP FENCE TILTING	1		2695032	SCREW, LOCK ASSY ITEMS 12, 14, 16, 50	1
44	6715223	SCREW, FENCE TILTING	1		2109018	CUTTERHEAD ASSY ITEMS 27, TO 29, 31, 32,	1
48	3526205	NUT HEX 5/8 - 18	2		2195007	FENCE ASSY. ITEMS 9, 15, 44, 52 TO 56, 58, 59, 61, 63, 64	1
49	3406016	KNOB, HANDLE	2		2268005	HANDLE ASSY. FENCE TILTING ITEMS, 33, 34	1
50	3268002	HANDLE, LOCK	2		2670015	ROD ASSY TILT. ITEMS 39 TO 41, 43, 62	1
51	3695206	SCREW, LOCK	2		2440005	LOCK ASSY PLUNGER ITEMS 35 TO 38	1
52	3064233	BRACKET, FENCE LOCK	1		2695010	SCREW, LOCK ASSY ITEMS 49, 50	1
53	3042197	BASE, FENCE SLIDE	1		2250011	GUARD, ASSY CUTTERHEAD ITEMS 66 TO 70	1
54	6716117	SCREW, 3/8 - 16 X 1 1/2 SLOTTED SET	4		2386002	KEY ASSY. FENCE SLIDING ITEMS 75, 76	1
55	6516009	NUT, HEX JAM 3/8 - 16	4		2438001	LIFTER ASSY CUTTERHEAD KNIFE ITEMS 77, 78	1
56	3282009	HINGE, FENCE MTG.	1		2526001	NUT ASSY. FENCE SLIDING ITEMS 79, 80	1
57	6515007	NUT, HEX, JAM 5/16 - 18	1		2244008	GIB, ASSY. CUTTERHEAD ITEMS 81, 82	1
58	6715088	SCREW, SQ. HD. 5/16 - 18 X 1	1				
59	3195121	FENCE, TABLE	1				
61	3055120	BLOCK, MOUNTING	1				
62	3728003	SLEEVE, FENCE TILTING	1				
63	6861501	WASHER, FLAT 1/2	3				
64	6714114	SCREW, RD. HD. 1/4 - 20 X 3/8	2				
65	6861101	WASHER 1/4 FLAT	2				
66	3250013	GUARD CUTTERHEAD	1				

PARTS: Exploded View

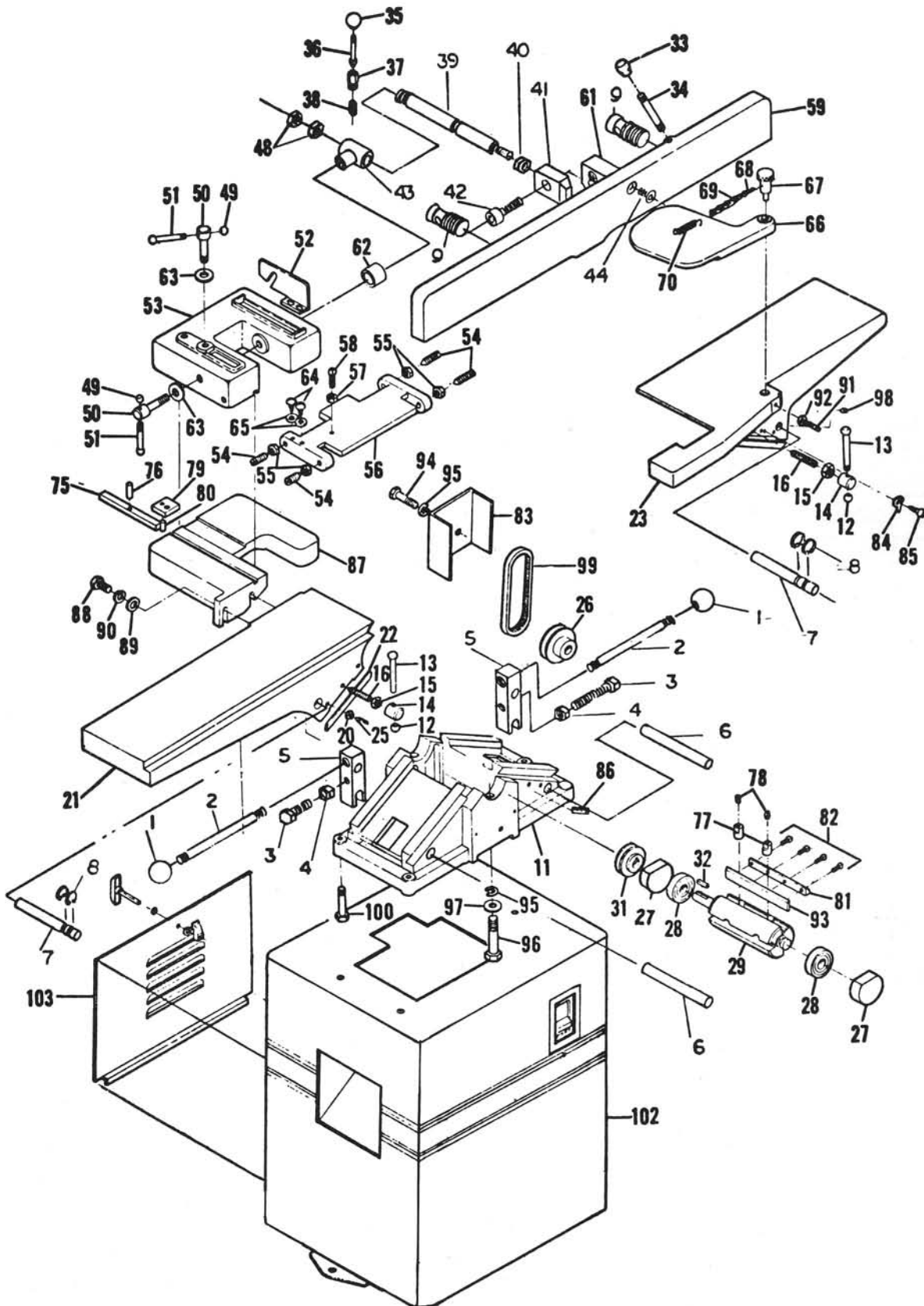

ELECTRICAL: Parts List

MANUAL

REF.	QTY.	POWERMATIC NO.	MFG. DESCRIPTION
S1	1	(30) 6821135 (10) 6821134	SWITCH, FURNAS 12BA34P SWITCH, FURNAS 12BA24P

MAGNETIC

REF.	QTY.	POWERMATIC NO.	MFG. DESCRIPTION
M1	1	(30) 6816111 (10) 6816105	STARTER, MAGNETIC, FURNAS, 14BF32BC71 STARTER, MAGNETIC, FURNAS, 14CF12BA7
(PB 1) (PB 2)		6821014	SWITCH, FURNAS, MOMENTARY PB, B28731B

MAGNETIC WITH LOW VOLTAGE CONTROL

REF.	QTY.	POWERMATIC NO.	MFG. DESCRIPTION
(PB 1) (PB 2)	1	6821014	SWITCH, FURNAS, MOMENTARY PB, B28731B
T1	1	6831068	TRANSFORMER 115/230-24V, 50 VA
		6831069	TRANSFORMER 230-460-24V, 75 VA
		6831070	TRANSFORMER 230/460-115V, 50VA
1M (WITH XMF)	1	6816119	STARTER, MAG. W/XMR. 10, 24V, FURNAS 14CF107013
		6816138	STARTER, MAG. W/XMR. 10, 115V, FURNAS 14CF107017
		6816122	STARTER, MAG. W/XMR. 30, 24V, FURNAS 14BF32BJ71BD
		6816126	STARTER, MAG. W/XMR. 30, 115V, FURNAS 14BF32BA71BA
MTR.	1	6470801	MOTOR, ELECT. 3/4 HP, 10 3600 RPM, 115/230V, 56 FR
		6470809	MOTOR, ELECT. 3/4 HP, 30, 3600 RPM, 200V, 56 FR
		6470810	MOTOR, ELECT. 3/4 HP, 30, 3600 RPM, 230/460V, 56 FR

ELECTRICAL: Schematic

MANUAL

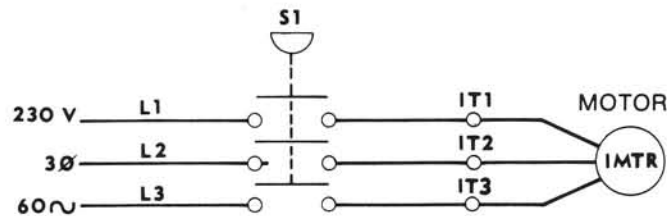

MAGNETIC

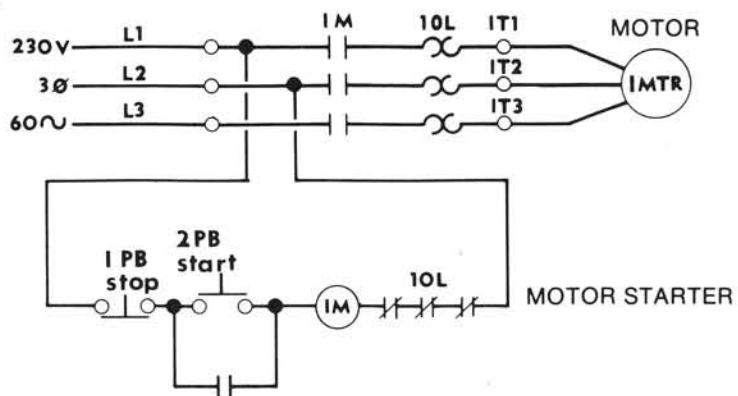

MAGNETIC W/LOW VOLTAGE CONTROL

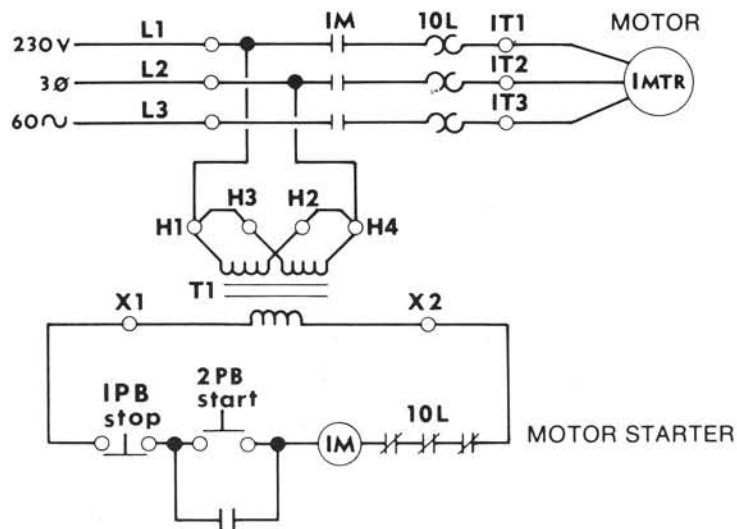

NOTE: FOR SINGLE PHASE UNITS, OMIT LINE L3

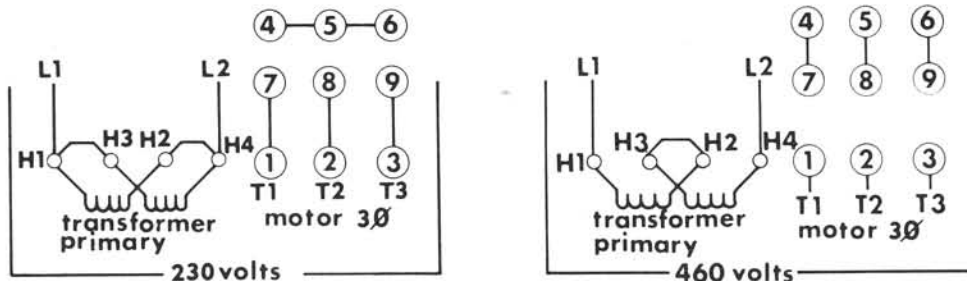

PREVENTIVE MAINTENANCE CHECK LIST

OPERATOR _____ DATE: _____
 MODEL NO. _____ S/N _____ ASSET NO. _____

SATISFACTORY; ACCEPTABLE, BUT NEEDS ATTENTION;
 UNSATISFACTORY--RED TAG

1. ALL KNIVES SET TO BE NO MORE THAN .015 TO .025 FROM CUTTERHEAD BODY.....S A U
2. KNIVES LOCKED SECURELY IN CUTTERHEAD.....S U
3. KNIVES SHARP AND FREE OF NICKS AND GROOVES.....S U
4. GUARD IN PLACE AND WORKING PROPERLY.....S U
5. OUT-FEED TABLE IN LINE WITH TOP OF ARC OF CUTTERHEAD. ALL BLADES ARC WITHIN .002.....S A U
6. ALL SAFETY DECALS IN PLACE.....S U
7. WORKING AREA AROUND MACHINE MARKED OFF.....S U
8. ANTI-SKID STRIPS OR FLOOR AREA WHERE OPERATOR NORMALLY STANDS.....S U
9. VARIOUS TYPES OF PUSH BLOCKS READILY AVAILABLE TO OPERATORS..S A U
10. KICKBACK PATH NOT AIMED AT OTHER WORK AREAS, AISLES, OR DOORWAYS.....S U
11. FENCE CLAMPS TIGHTLY TO BASE AND TO FENCE BRACKET.....S A U
12. NO MISSING PARTS OR LOOSE SCREWS.....S A U
13. MACHINE IS BOLTED TO FLOOR.....S A U
14. GIBS ARE ADJUSTED TO LIGHT DRAG ON ADJUSTMENTS FOR BOTH INFEED AND OUTFEED TABLES.....S A U
15. LOCKS ON INFEED AND OUTFEED TABLES ARE IN POSITION AND OPERATE PROPERLY.....S A U
16. TABLE FREE OF PITCH, RESIN OR ANY FOREIGN MATERIAL.....S A U
17. OTHER PROBLEMS.....S A U

FORWARD A COPY OF THIS
 FILLED OUT FORM TO
 YOUR SUPERVISOR FOR
 IMMEDIATE ACTION

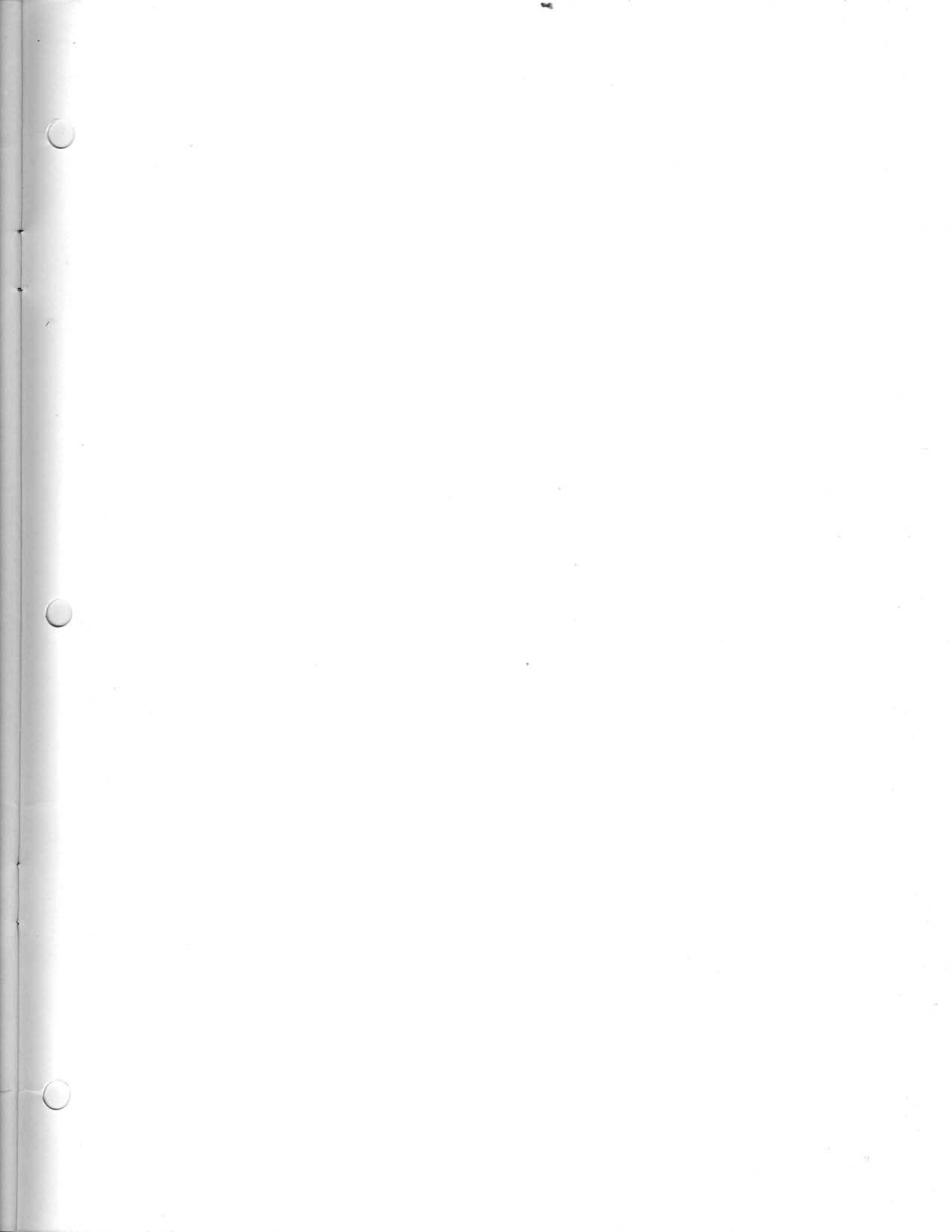

POWERMATIC[®] —  HOUDAILLE[®], INC.
McMinnville, Tennessee 37110 (615) 473-5551