



Catalog No. 39

ROSE TOOLS, INC.

MILLERS FALLS COMPANY

Millers Falls, Mass., U.S.A.

Millers Falls Company

E. P. STOUGHTON, . . . Chairman

PHILIP ROGERS, . . . President JOHN W. SMEAD, . . . Vice-President

GEO. U. HATCH, . . . Vice-President GEO. W. NIMS, Treasurer



Catalog No. 39
January, 1925

Main Office and Works

MILLERS FALLS, MASS., U. S. A.

Factories
Millers Falls, Mass., U. S. A.
West Haven, Conn., U. S. A.
Brattleboro, Vt., U. S. A.

Chicago Office and
Warehouse
9 So. Clinton St.
Chicago, Ill., U. S. A.

Export Office
28 Warren Street
New York City
U. S. A.

CABLE ADDRESS: "MILLERFALL" NEW YORK

Codes: A. B. C. 5th Edition, Lieber's
Western Union, Bentley's

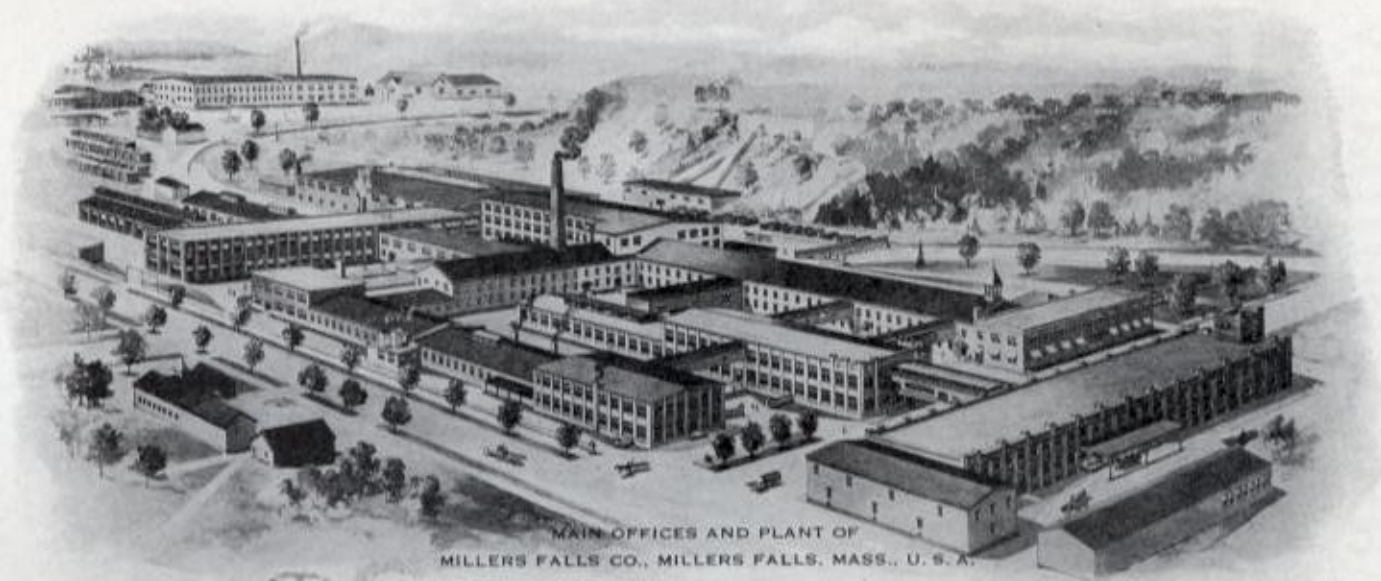

MAIN OFFICES AND PLANT OF
MILLERS FALLS CO., MILLERS FALLS, MASS., U. S. A.

ROSE TOOLS, INC.

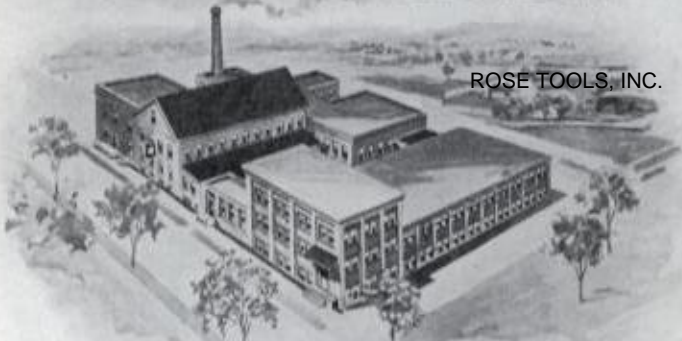

HACK SAW PLANT, FORMERLY
WEST HAVEN MFG. CO., WEST HAVEN, CONN., U. S. A.



AUTOMOBILE JACK PLANT
BRATTLEBORO, VERMONT, U. S. A.

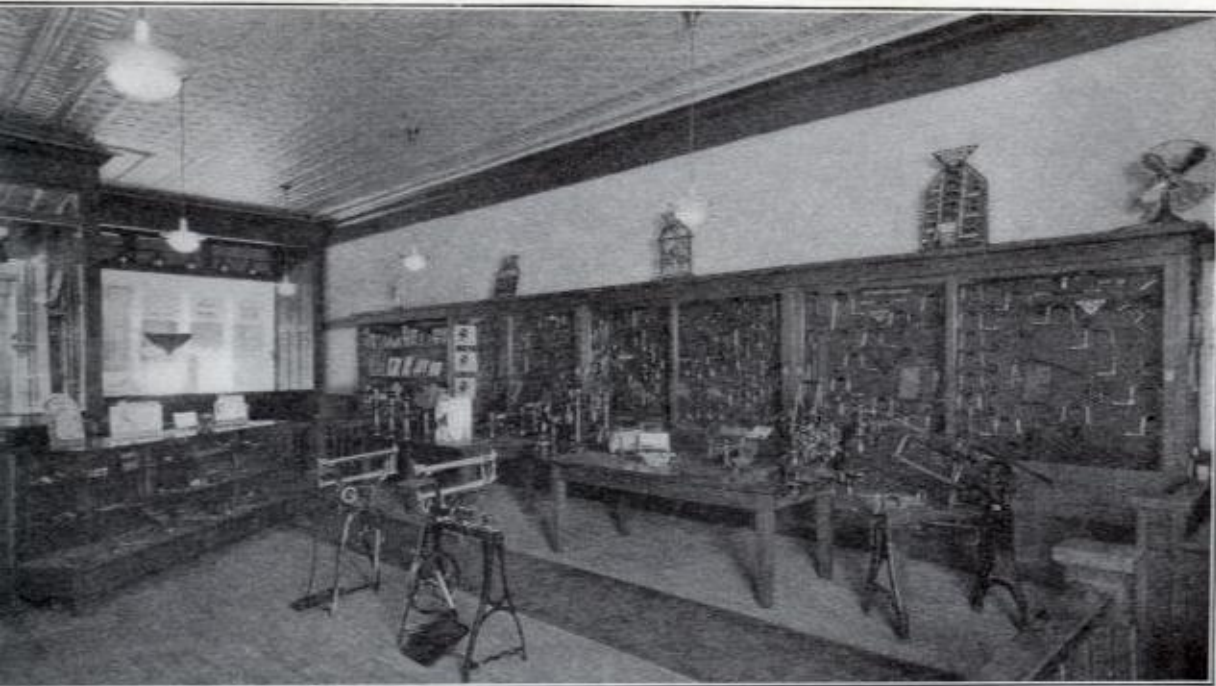

The New York Home
and Export Office
of Millers Falls Products
28 Warren Street

THE Millers Falls Company has maintained a New York office for over fifty-three years.

The first New York office was opened in November, 1868 at Number 87 Beekman Street. After occupying three other locations, it was finally moved in May, 1898 to Number 28 Warren Street, its present address, in the heart of a wholesale hardware district.

In November, 1919, an opportunity was afforded to purchase the property. The building, consisting of five stories and two basement floors, was thoroughly renovated and remodeled throughout, and no expense spared to make it one of the finest office buildings of its kind in the vicinity. The upper floors are rented to high class firms as offices and showrooms while the MILLERS FALLS COMPANY occupies the entire ground floor and basements.

Number 28 Warren Street is headquarters for the Export Department, and its showrooms are open to all customers who wish to become acquainted with Millers Falls products, at first-hand, and to save the time and expense of a trip to the factory in Millers Falls, Massachusetts. A cordial invitation is extended to the trade throughout the world, to visit this exhibition of Carpenters' and Mechanics' Tools, Hack Saw blades, Automobile Jacks and accessories tools at any and all times.

The Chicago Office

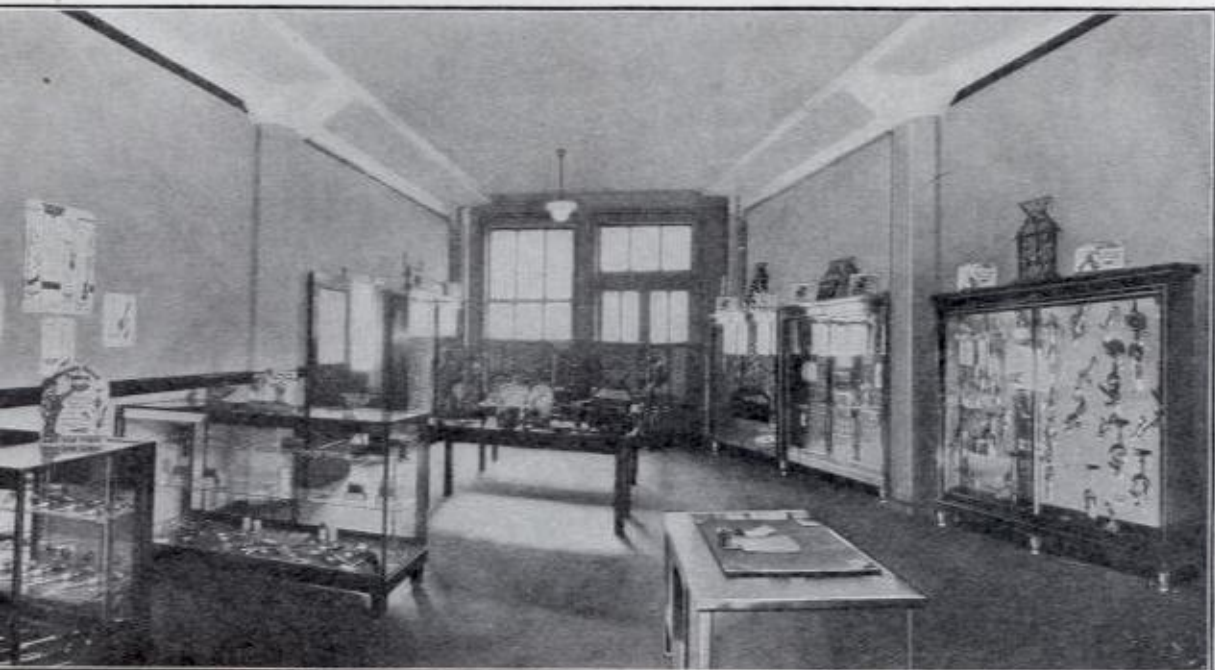

ROSE TOOLS, INC.

CHICAGO OFFICE AND WAREHOUSE 9 South Clinton Street, Chicago

In order to better serve our very large and rapidly growing Western trade we have established a Chicago Office and Warehouse. Our line of tools is attractively displayed and readily accessible to visitors who may wish to examine and inspect same. A complete stock, including extra parts, is carried at all times in quantities sufficient to care for every reasonable sized requisition.

When next in Chicago come in and pay us a visit. We will be very glad to place every facility at your disposal.



FOREWORD

A GAIN we present to our customers a new catalog, which supersedes our former catalog No. 38 issued in January, 1922. Since the issuance of our last catalog we have produced a large variety of new items, and many Millers Falls tools which have been standard for years have been improved in design and construction. You will note that we have indicated throughout the addition of new tools and have also called attention to changes in design which have become effective during the past three years.

It must be evident to our customers that Millers Falls Company is progressing. Our policies may be summed up briefly in two ways:

First—We are endeavoring to anticipate the needs of our customers by eliminating tools which are obsolete and by adding new items to meet popular demand, realizing that both customer and manufacturer can make money only by a rapid turnover of goods. We expect to extend our lines continually in proportion to the demands of a changing world.

Second—We will always strive to make the best tools of the kind that can be made. Our prices are not always the lowest, but it is our belief that it pays to buy good tools and that poor tools are not a good investment for the consumer. The Millers Falls trade-mark possesses greater value to you and to us year after year.

Perhaps our greatest development for the past ten years is the addition of a line of spiral and ratchet screw drivers, and we now offer a complete line. Our ratchet screw drivers were placed on the market in 1922 with marked success. In January, 1923 we offered our spiral ratchet screw drivers and there are indications that this line will become as popular as other major lines of long reputation. We have also added a new and popular automatic drill. Altogether we have now perfected a complete line of automatic tools consisting of ratchet and spiral screw drivers and automatic drills, all of which will appeal to the distributor of tools of this description.

We appreciate the increased interest shown in our products by a large majority of our customers. We shall endeavor to merit greater support by rendering an increasingly better service.

MILLERS FALLS COMPANY,
MILLERS FALLS, MASS.

January, 1925.

TERMS

All goods are sold F. O. B. cars, Factory—either Millers Falls, Mass., Brattleboro, Vt. or West Haven, Conn. Export shipments are F. O. B. arrival New York City.

Invoices are payable in New York or Boston funds, net 30 days from date rendered, or less 2% cash discount, if paid within ten days.

Remittances should be mailed to our Main Office at Millers Falls, Mass.

GUARANTEE

Every tool stamped "Millers Falls" is warranted free from defects in material and in workmanship. Should any tool show such a defect, we will repair or replace it free of charge.

ELECTROTYPES

ROSE TOOLS, INC.

For the convenience of our customers, who issue catalogs, or other printed matter, we offer two sizes of electrotypes for each of our tools, one of the size used in this catalog; the other approximately 2 1-4" wide for one column use. These are supplied without charge.

RETURNED GOODS

We cannot accept for credit goods returned without permission.

Shipping instructions should be obtained for any goods to be returned for any reason other than for repair.

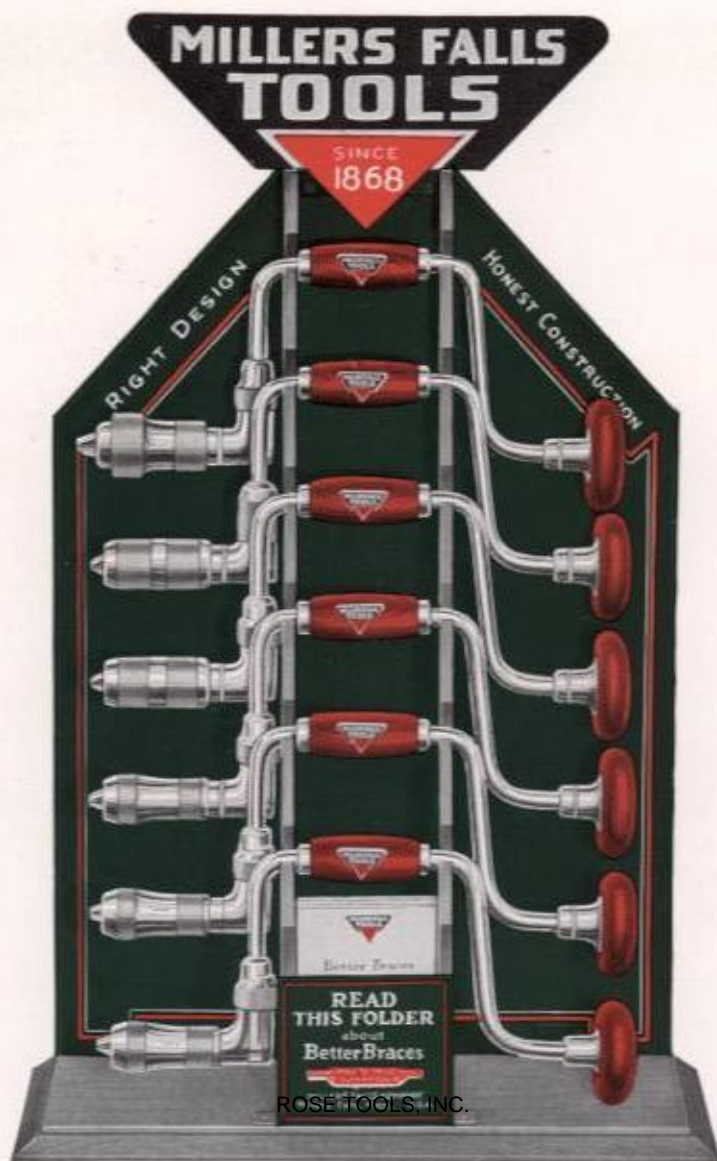

BRACE DISPLAY, No. 600

THIS New Millers Falls Brace Display fairly speaks an invitation to the prospective buyer to pick up and examine each brace. It has an individuality that makes it stand out in any window or on any counter. It is compact, takes up little space, strongly built and artistic in design. It will demand attention from any part of your store and add to its general appearance. The fixture itself is given to you free of charge with an order for the following Millers Falls Braces:

1/6 doz. No. 772

1/6 doz. No. 8132

1/6 doz. No. 322

1/6 doz. No. 732

1/6 doz. No. 32

1/6 doz. No. 422

One hundred descriptive leaflets imprinted with dealer's name and address supplied with each display.

SPECIFICATIONS

Height—32 inches to top of trade mark.

Width—18 inches.

Base of Wood.

Back of tin on wood frame.

Wood rack for holding Braces.

Illustration shows actual colors.

Shipping weight, 100 pounds.

Code—Amite

Weight, with 6 braces, 26 lbs.

EACH FIXTURE PACKED IN AN INDIVIDUAL CARTON.



BRACES

Improvements made in Millers Falls braces during 1923 and 1924 have set a new standard in Brace construction.

Foremost is the improved chuck on Nos. 772 and 872 series. By means of a rectangular opening in the shell—instead of round as formerly—its capacity has been made greater—and will accommodate extra large bit shanks. The jaws are longer and heavier.

Of equal importance are the changes in the lower priced braces. Six series have ratchet sockets of new design, improved ratchet gears and pawls—together with a better finish on the heads and shells.

ROSE TOOLS, INC.

Steel chuck shells are now used on all the better quality braces.

Utmost care and thought is given to every detail of manufacture. None but the finest imported cocobolo wood is used on the better grade braces; the chuck bodies are of solid bar steel; jaws are of high carbon steel; ratchet rings are of steel with machine cut cams; the sweep rods are threaded, soldered and pinned into the crooked socket.

The Millers Falls line today embraces five distinct styles into which are incorporated eighty numbers. They cover every possible brace requirement.



Ratchet Braces

Nos. 769-773

Improved

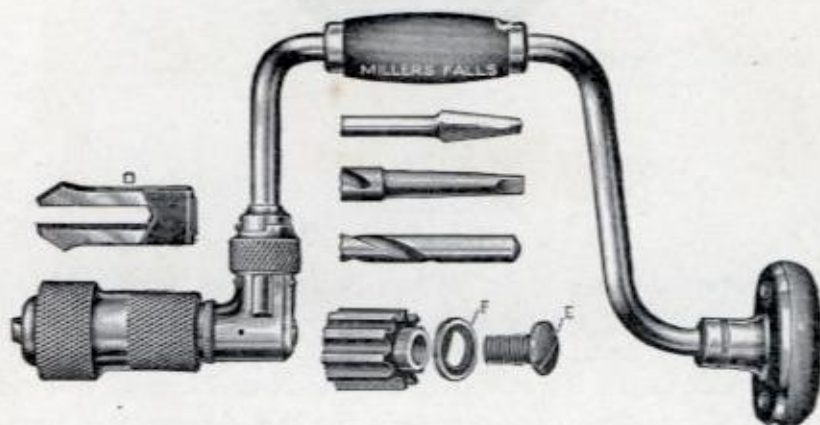

These are our highest quality braces, and are unsurpassed for ease of operation in heavy work. They are ball bearing at every possible point and run practically without friction.

Improved chuck having ROSE TOOLS, INC. ing in the shell, with corners cut away to accommodate extra large bit shanks.

Figures E and F show patent cup washer which cannot work loose.

Specifications

Cocobolo head and handle. Exposed metal parts nickel plated and buffed.

Chuck—Lion ball bearing. Jaws have parallel milled grooves which grip along their entire length. Holds bit shanks, round from $\frac{1}{8}$ to $\frac{1}{2}$ inch and No. 1 Morse taper shanks.

Ratchet—boxed. Head—ball bearing. Full steel clad.

Handle—Inserted metal rings.

Nos.	769	770	771	772	773
Sweep	16 in.	14 in.	12 in.	10 in.	8 in.
Weight, each	4 $\frac{1}{2}$ lbs.	4 lbs.	3 $\frac{1}{2}$ lbs.	3 $\frac{3}{8}$ lbs.	3 lbs.
Price each	\$6.80	6.45	6.30	6.05	6.00
Code	Aback	Abacu	Abaft	Aband	Abask

Packed ten dozen in a box, thirty-six in a case.



Ratchet Braces

Nos. 870-872

Improved

This series is identical with Nos. 769-773 except that the ratchet is of the concealed type and the sweep handle is ball bearing.

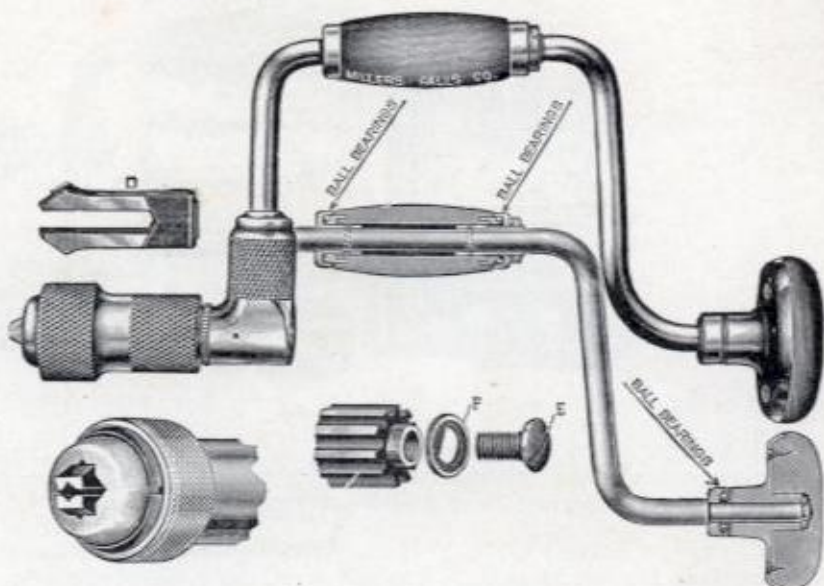

Nos.	870	871	872
Sweep	14 in.	12 in.	10 in.
Weight each	4 lbs.	3½ lbs.	3¾ lbs.
Price each	\$7.60	7.45	7.15
Code	Aboti	Abbat	Abbaz

Packed two in a box, thirty-six in a case.

New

Nos. 1050-1054

ROSE TOOLS, INC.

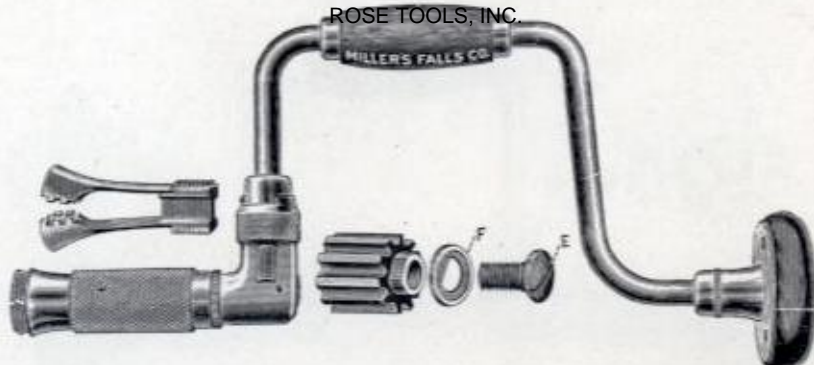

Chuck is of special design, is extra strong and heavily knurled. The jaws are of the interlocking type, self-centering, forged from steel and spring tempered.

Except for Chuck same as No. 769-773.

Nos.	1050	1051	1052	1053	1054
Sweep	14 in.	12 in.	10 in.	8 in.	6 in.
Weight each	3⅝ lbs.	3¼ lbs.	3 lbs.	2¾ lbs.	2½ lbs.
Price each	\$5.35	5.20	4.95	4.90	4.90
Code	Above	Abord	Abose	Aboti	Abowk

Packed two in a box, thirty-six in a case.



Ratchet Braces (Holdall)

Nos. 730-734

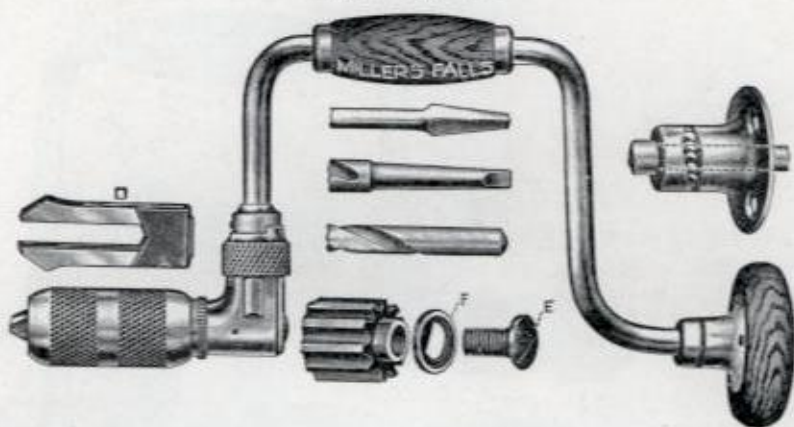

This series is the most popular of our better grade braces. Since first offered it has been popularly known as the "Holdall" brace—this name having reference to the chuck which holds bit shanks, round from $\frac{1}{8}$ to $\frac{1}{2}$ inch and No. 1 Morse taper shanks.

Specifications

Cocobolo head and handle. Exposed metal parts nickel plated and buffed.

Chuck—Master. Jaws have parallel milled grooves which grip along their entire length.

Ratchet—Boxed. Head—Ball bearing. Steel quill. Handle—Inserted metal rings.

Nos.	730	731	732	733	734
Sweep	14 in.	12 in.	10 in.	8 in.	6 in.
Weight each	3½ lbs.	3¼ lbs.	3⅙ lbs.	2¾ lbs.	2⅝ lbs.
Price each	\$5.55	5.40	5.15	5.10	5.10
Code	Abbey	Abbot	Abdic	Abdok	Abeam

Packed two in a box, thirty-six in a case.

ROSE TOOLS, INC.

Nos. 8130-8133

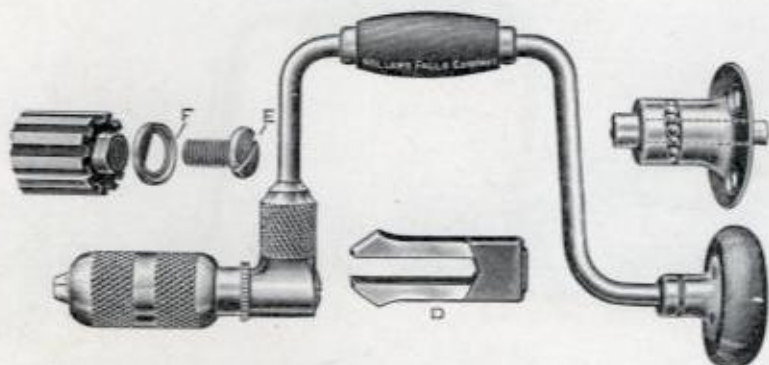

Except for the ratchet which is of the concealed type, these braces are identical with No. 730 series.

Specifications

Nos.	8130	8131	8132	8133
Sweep	14 in.	12 in.	10 in.	8 in.
Weight each	3½ lbs.	3¼ lbs.	3⅙ lbs.	2¾ lbs.
Price each	\$6.20	6.10	5.80	5.75
Code	Abode	Aboli	Ablot	Aborg

Packed two in a box, thirty-six in a case.



Ratchet Braces

Nos. 30-34

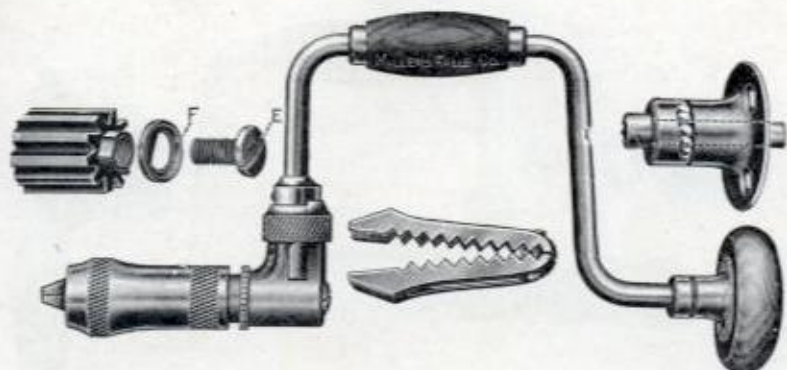

There is no brace better known to carpenters than No. 32 of this series. Its sale exceeds that of any of our higher priced braces.

The braces of this series will fulfill every boring requirement where bit shanks only are used.

Specifications

Cocobolo head and handle. Exposed metal parts nickel plated and buffed.

Chuck—Barber with forged steel alligator jaws. Holds bit shanks only.

Ratchet—Boxed. Head—Ball bearing. Steel quill. Handle—Inserted metal rings.

Nos.	30	31	32	33	34
Sweep	14 in.	12 in.	10 in.	8 in.	6 in.
Weight each	3 $\frac{3}{8}$ lbs.	3 lbs.	2 $\frac{7}{8}$ lbs.	2 $\frac{1}{2}$ lbs.	2 $\frac{1}{4}$ lbs.
Price each	\$5.10	4.95	4.70	4.65	4.65
Code	<i>Absco</i>	<i>Absen</i>	<i>Absol</i>	<i>Absik</i>	<i>Absta</i>

Packed two in a box, thirty-six in a case.

Nos. 30A-34A

ROSE TOOLS, INC.

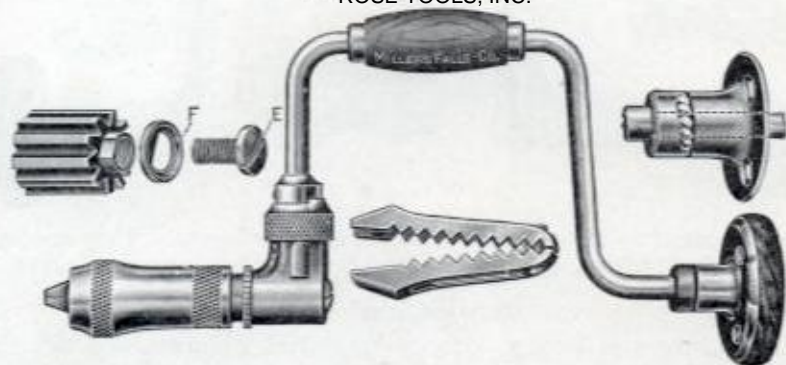

This series differs from Nos. 30-34 series only in the head, which is full steel clad.

Specifications

Nos.	30A	31A	32A	33A	34A
Sweep	14 in.	12 in.	10 in.	8 in.	6 in.
Weight each	3 $\frac{1}{2}$ lbs.	3 lbs.	2 $\frac{7}{8}$ lbs.	2 $\frac{3}{8}$ lbs.	2 $\frac{3}{8}$ lbs.
Price each	\$5.35	5.20	4.95	4.90	4.90
Code	<i>Abset</i>	<i>Abtsi</i>	<i>Abtar</i>	<i>Abtok</i>	<i>Abuda</i>

Packed two in a box, thirty-six in a case.

Ratchet Braces

Nos. 130-133

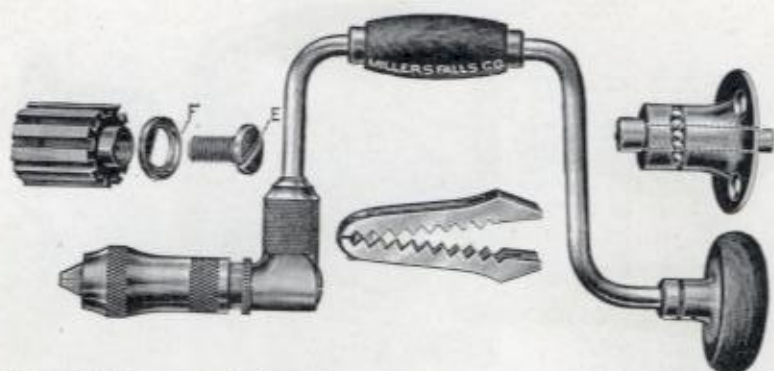

For those who prefer the concealed ratchet we offer this series. Except for this detail they are the same as No. 30 series.

Nos.	130	131	132	133
Sweep	14 in.	12 in.	10 in.	8 in.
Weight each	3 $\frac{3}{8}$ lbs.	3 lbs.	2 $\frac{7}{8}$ lbs.	2 $\frac{5}{8}$ lbs.
Price each	\$5.45	5.25	5.00	5.00
Code	<i>Abyss</i>	<i>Acade</i>	<i>Acade</i>	<i>Accel</i>

Packed two in a box, thirty-six in a case.

Improved

Nos. 321-323

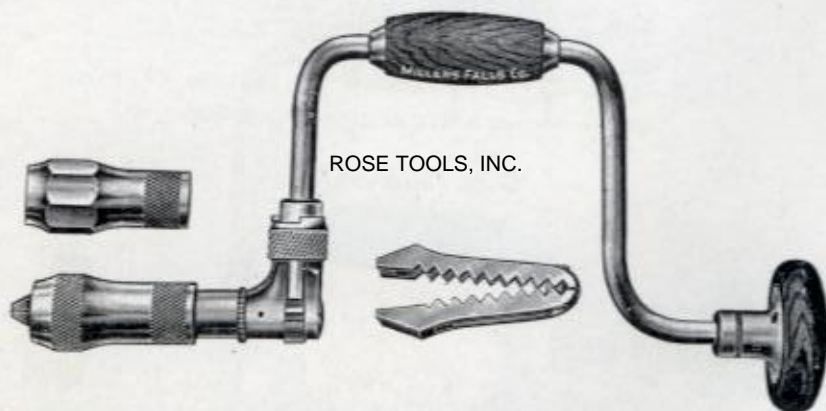

Every feature essential to a good brace is found in these braces. They are lower priced than No. 32 series because of native hardwood handles and head and less expensive ratchet construction.

Specifications

Stained hardwood head and handles. Exposed metal parts polished and nickel plated.
 Chuck—Barber with forged alligator jaws. Ratchet—Semi-boxed.
 Handle—inserted metal rings. Head—ball bearing.

Nos.	321	322	323
Sweep	12 in.	10 in.	8 in.
Weight each	2 $\frac{7}{8}$ lbs.	2 $\frac{3}{4}$ lbs.	2 $\frac{3}{8}$ lbs.
Price each	\$4.05	3.90	3.85
Code	<i>Achei</i>	<i>Acoly</i>	<i>Acorn</i>

Packed six in a box, thirty-six in a case.

Furnished with octagonal chuck shell, each, extra, \$0.05.



Ratchet Braces

Nos. 1321-1324

Improved

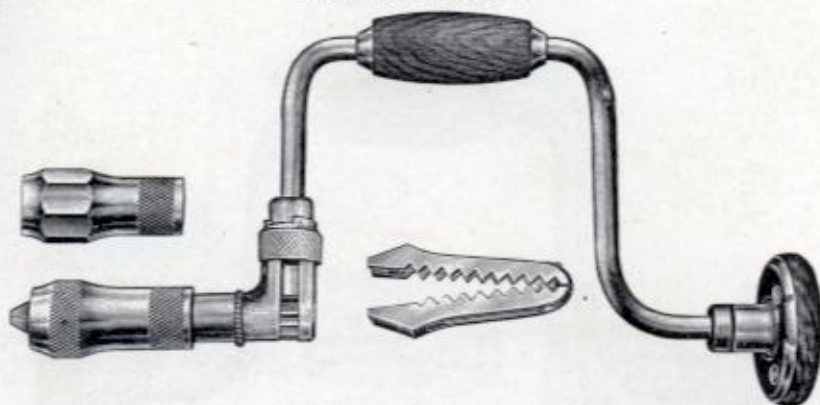

These braces are the same as Nos. 321-323, except have ebonized heads and handles, with heads full steel clad, and friction washer to minimize friction.

Nos.	1321	1322	1323	1324
Sweep	12 in.	10 in.	8 in.	6 in.
Weight each	3 lbs.	2 $\frac{3}{4}$ lbs.	2 $\frac{1}{2}$ lbs.	2 $\frac{1}{4}$ lbs.
Price each	\$3.85	3.65	3.60	3.60
Code	<i>Acrim</i>	<i>Acrob</i>	<i>Activ</i>	<i>Actor</i>

Packed six in a box, thirty-six in a case.

Furnished with octagonal chucks, each, extra, \$0.05.

Improved

Nos. 421-423

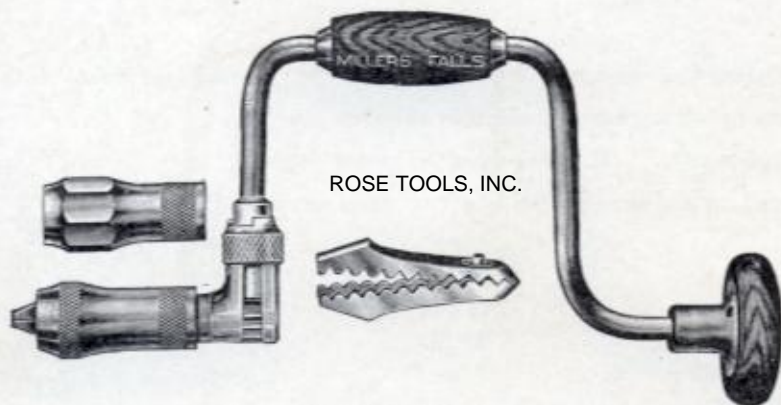

ROSE TOOLS, INC.

Specifications

An inexpensive nickeled series made for those whose work does not require the refinements of the higher priced braces.

Stained hardwood head and handle. Exposed parts polished and nickel plated.

Chuck—Barber, with improved malleable alligator jaws. Ratchet—semi-boxed.

Handle—inserted metal rings.

Head—screwed on and securely held by two screws. Plain bearing.

Nos.	421	422	423
Sweep	12 in.	10 in.	8 in.
Weight each	2 $\frac{3}{4}$ lbs.	2 $\frac{5}{8}$ lbs.	2 $\frac{3}{8}$ lbs.
Price each	\$3.05	2.95	2.90
Code	<i>Adjec</i>	<i>Adjou</i>	<i>Adjun</i>

Packed six in a box, thirty-six in a case.

Furnished with octagonal chucks, each, extra, \$0.05.

MILLERS FALLS COMPANY



Ratchet Braces

Nos. 1661-1663

Improved

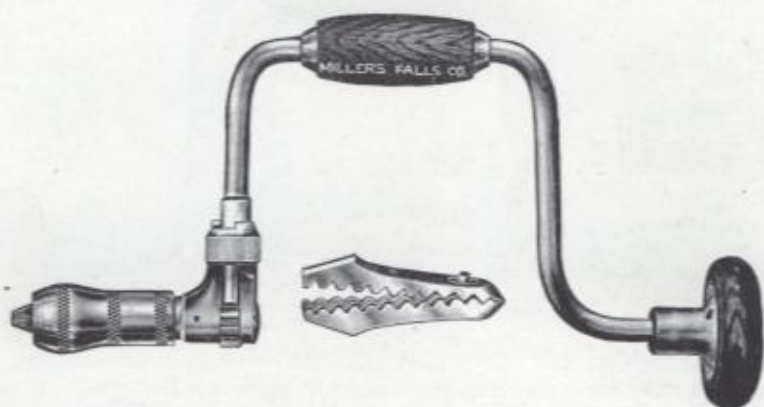

This is our most popular ratchet brace.

Within the past year several improvements have been made in this series—the most important being a ratchet socket of new design, improved ratchet gear and pawls—and a better finish on the heads and shells.

These features combined with an unusually low price for a brace of this quality are responsible for its enjoying the largest sale of any brace we make.

ROSE TOOLS, INC.

Specifications

Stained hardwood head and handles. Exposed parts polished and nickel plated.

Chuck—Barber with improved malleable alligator jaws.

Ratchet—semi-boxed. Handle—inserted metal rings.

Head—screwed on and securely held by two wood screws. Plain bearing.

Nos.	1661	1662	1663
Sweep	12 in.	10 in.	8 in.
Weight each	2 $\frac{3}{8}$ lbs.	2 $\frac{1}{4}$ lbs.	2 lbs.
Price each	\$2.15	2.10	2.05
Code	<i>Adver</i>	<i>Advoc</i>	<i>Acoli</i>

Packed six in a box, thirty-six in a case.

Nos. 161-163

These are the same braces as Nos. 1661-1663 with exposed metal parts, polished instead of nickel plated.

Nos.	161	162	163
Sweep	12 in.	10 in.	8 in.
Weight each	2 $\frac{3}{4}$ lbs.	2 $\frac{1}{4}$ lbs.	2 lbs.
Price each	\$2.00	1.95	1.90
Code	<i>Afara</i>	<i>Affab</i>	<i>Affec</i>



Ratchet Braces

Nos. 631-633

Improved

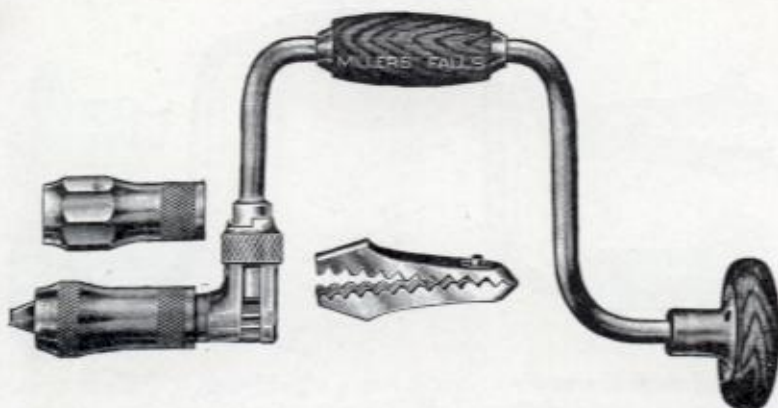

These braces are the same as Nos. 421-423 (page 10) except that the exposed metal parts are polished instead of nickel plated.

Specifications

Nos.	631	632	633
Sweep	12 in.	10 in.	8 in.
Weight	2 $\frac{3}{4}$ lbs.	2 $\frac{5}{8}$ lbs.	2 $\frac{3}{8}$ lbs.
Price each	\$2.70	2.60	2.55
Code	<i>Adroi</i>	<i>Adula</i>	<i>Advan</i>

Packed six in a box, thirty-six in a case.

Nos. 261-263

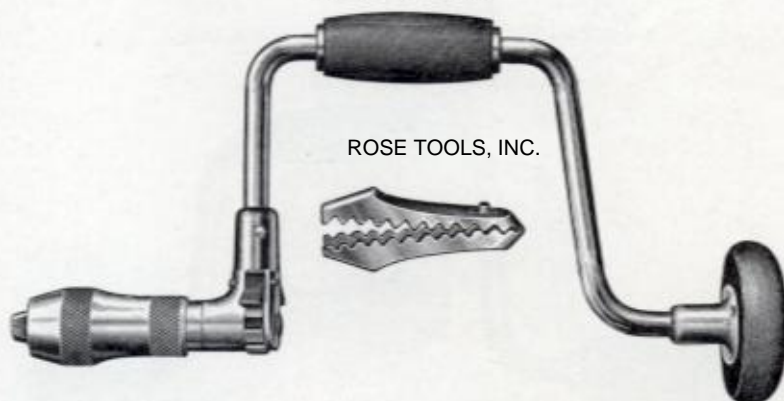

ROSE TOOLS, INC.

These are our lowest priced ratchet braces. They differ from our other inexpensive braces in finish and in the ratchet construction.

Specifications

Stained hardwood head and handle.
 Chuck—Barber. Cast alligator jaws.
 Ratchet—"pick out" pawl type.
 Head—screwed on and held by two wood screws. Plain bearing.

Nos.	261	262	263
Sweep	12 in.	10 in.	8 in.
Weight each	2 $\frac{1}{4}$ lbs.	2 lbs.	1 $\frac{7}{8}$ lbs.
Price each	\$1.90	1.85	1.80
Code	<i>Affli</i>	<i>Affue</i>	<i>Afray</i>

Packed six in a box, thirty-six in a case.



Plain or Sleeve Braces

Nos. 12-14

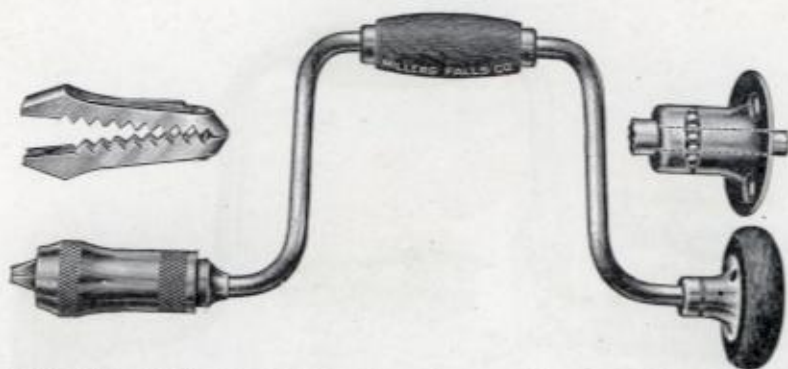

For certain types of work the ratchet on a brace is superfluous. Under such circumstances the purchase of a plain brace is an object because it is lower priced than a ratchet brace of equal finish and build.

Nos. 12-14 are our highest quality plain braces.

Specifications

Cocobolo head and handle. Exposed metal parts polished and nickel plated.

Chuck—Barber. Forged alligator jaws.

Head—ball bearing. Handle—inserted metal rings.

Nos.	12	13	14
Sweep	10 in.	8 in.	6 in.
Weight each	2 $\frac{3}{8}$ lbs.	2 lbs.	1 $\frac{3}{4}$ lbs.
Price each	\$3.55	3.50	3.50
Code	<i>Accom</i>	<i>Acord</i>	<i>Acost</i>

Packed six in a box, thirty-six in a case.

Nos. 141-143

ROSE TOOLS, INC.

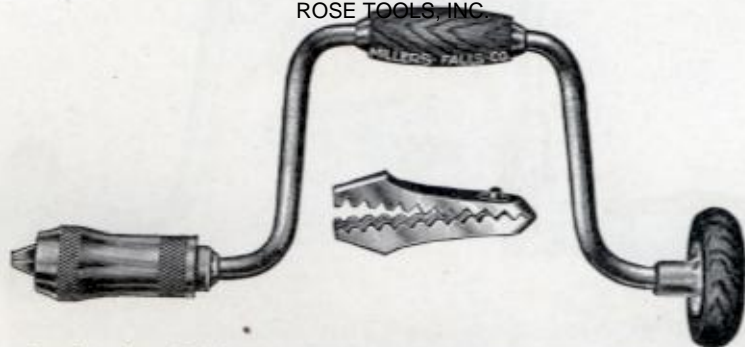

This is a low priced series of lighter construction and less expensive finish than Nos. 12-14.

Specifications

Stained hardwood head and handle. Exposed metal parts polished.

Chuck—Barber. Cast alligator jaws. Head—plain bearing. Head screwed on and securely held by two wood screws.

Nos.	141	142	143
Sweep	12 in.	10 in.	8 in.
Weight each	1 $\frac{7}{8}$ lbs.	1 $\frac{3}{4}$ lbs.	1 $\frac{5}{8}$ lbs.
Price each	\$1.10	1.05	1.05
Code	<i>Afida</i>	<i>Afli</i>	<i>Afino</i>

Packed six in a box, thirty-six in a case.



Plain or Sleeve Braces

Nos. 221-223



This series is built to meet a demand for a medium price brace of the sleeve type.

Specifications

Stained hardwood head and handle. Exposed metal parts polished and nickel plated.
 Chuck—Barber. Forged alligator jaws.
 Head—friction washer to minimize friction. Steel quill.
 Handle—inserted metal rings.

Nos.	221	222	223
Sweep	12 in.	10 in.	8 in.
Weight each	2 $\frac{3}{8}$ lbs.	2 $\frac{1}{4}$ lbs.	1 $\frac{7}{8}$ lbs.
Price each	\$2.45	2.25	2.20
Code	Adame	Adder	Adict

Packed six in a box, thirty-six in a case.

Nos. 21-23

ROSE TOOLS, INC.

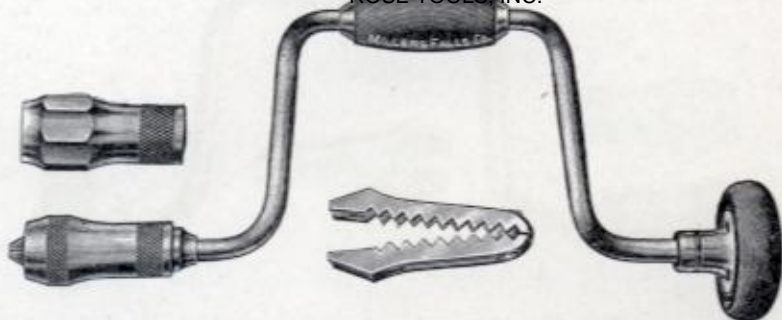

The same braces as Nos. 221-223 except are polished instead of nickel plated.

Specifications

Nos.	21	22	23
Sweep	12 in.	10 in.	8 in.
Weight each	2 $\frac{3}{8}$ lbs.	2 $\frac{1}{4}$ lbs.	1 $\frac{7}{8}$ lbs.
Price each	\$2.25	2.10	2.05
Code	Adher	Adieu	Adipo

Packed six in a box, thirty-six in a case.



Plain or Sleeve Braces

Nos. 401-403

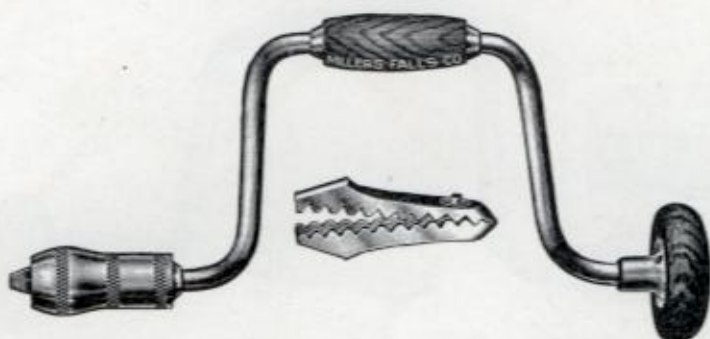

The essential difference between this and the Nos. 221-223 series is in the chuck and head.

Specifications

Stained hardwood head and handle. Exposed metal parts polished and nickel plated.
 Chuck—Barber. Cast alligator jaws. Head—plain bearing. Handle—inserted metal rings.

Nos.	401	402	403
Sweep	12 in.	10 in.	8 in.
Weight each	2¼ lbs.	2½ lbs.	1⅞ lbs.
Price each	\$1.95	1.85	1.80
Code	<i>Adjut</i>	<i>Admir</i>	<i>Admit</i>

Packed six in a box, thirty-six in a case.

Nos. 601-603

ROSE TOOLS, INC.



The same braces as Nos. 401-403, with polished instead of nickeled metal parts.

Specifications

Nos.	601	602	603
Sweep	12 in.	10 in.	8 in.
Weight each	2¼ lbs.	2½ lbs.	1⅞ lbs.
Price each	\$1.60	1.55	1.50
Code	<i>Adven</i>	<i>Advur</i>	<i>Adreb</i>

Packed six in a box, thirty-six in a case.



Corner Braces

Nos. 502-503

Improved

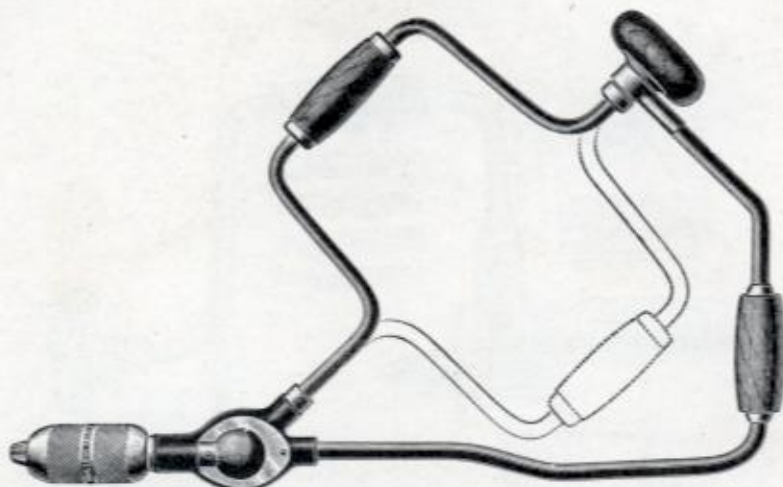

The purpose of this tool is to simplify the boring of holes in corners. It accomplishes such boring more easily and more rapidly than the ordinary ratchet brace.

Maximum power is derived because the pressure applied is directly in line with the chuck. Is easy to operate because there is ample space between sweep and steadying handle to allow free use of the hand.

Improved extra long spindle bearing which increases its strength.

The gears are enclosed for protection from dirt and resulting wear.

ROSE TOOLS, INC.

Specifications

Chuck—Master. Capacity bit shanks, round from $\frac{1}{8}$ to $\frac{1}{2}$ inch, and No. 1 Morse Taper shanks.

Gears—case hardened. Enclosed for protection, but easily accessible for oiling.

Ball thrust bearing at base of chuck.

Head—ball bearing.

Handles—free acting. Inserted metal rings. Both of stained hardwood.

Exposed metal parts, except frame casting, nickel plated. Frame casting japanned.

Nos.....	502	503
Sweep.....	10 in.	8 in.
Weight each.....	4 lbs.	3 $\frac{1}{8}$ lbs.
Length.....	17 in.	17 in.
Price each.....	\$7.75	7.40
Code.....	Agape	Agent

Packed two in a box.

Drill Brace (Ratchet)

No. 182

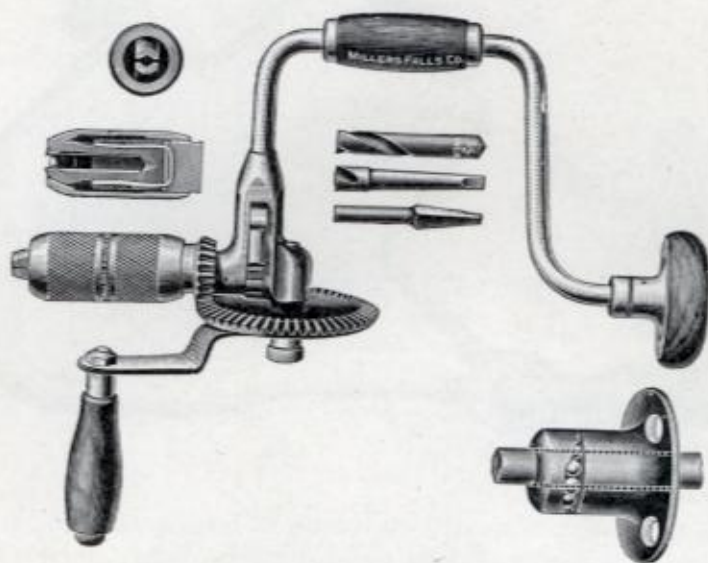

This tool, is, as the name implies, a combination bit brace and breast drill. With it one is equipped to do practically every kind of boring.

It takes but a moment to convert the brace into a breast drill for the greater power necessary to drill metal, cement or any hard material.

The reverse operation is as easily and quickly done.

The tool is invaluable to anyone whose work is not confined to one kind of drilling.

Specifications

Chuck—Master. Capacity—bit shanks, round from $\frac{1}{8}$ to $\frac{1}{2}$ inch, and No. 1 Morse taper shanks.

Ratchet—open.

Gear Ratio—3 to 1.

Brace Sweep—10 inch.

Head—ball bearing.

Handle—free acting. Inserted metal rings. Stained hardwood.

Large gear red.

Other metal parts nickel plated.

Weight each, 4 lbs.

Price each, \$8.35

Code—Aftma

Packed one in a box.



Whimble Brace

No. 7312

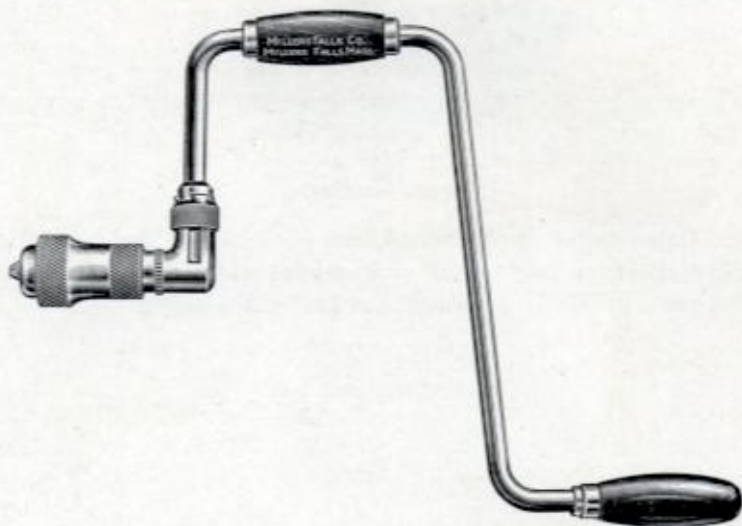
Improved

Ship builders, bridge builders and others whose work requires an unusually powerful sweep will find this brace a strong, sturdy tool, capable of standing the rough use to which it is necessarily put.

ROSE TOOLS, INC.

Specifications

Chuck—Lion, ball bearing. Holds, with vise-like grip, bit shanks, round from $\frac{1}{8}$ to $\frac{1}{2}$ inch and No. 1 Morse Taper shanks. Sweep Rod— $\frac{9}{16}$ inch steel stock. Ratchet—boxed.

Distance from center handle to main axis 6 inches. Upper handle offset 6 inches from main axis.

Handles—Free acting. Stained hardwood. Exposed metal parts polished and nickel plated.

Weight each, $3\frac{3}{4}$ lbs.

Code—Astut

Price each, \$5.65

Packed two in a box.

Angular Bit Stock

Improved

No. 108



Used with a bit brace or breast drill is an efficient tool for drilling at an angle. Can be used as a bit extension in straight work.

Specifications

Chuck—Master. Capacity bit shanks, round from $\frac{1}{8}$ to $\frac{1}{2}$ inch, and No. 1 Morse taper shanks. Boring angle adjustable from 180° to 125° . Steel joint and pins. Main casting japanned. Chuck and other parts polished. Length (at 180°) $12\frac{1}{2}$ inches.

Weight each, 2 lbs.

Code—Acaba

Price each, \$2.90

Packed one in a box.

Hollow Auger

No. 3

ROSE TOOLS, INC.

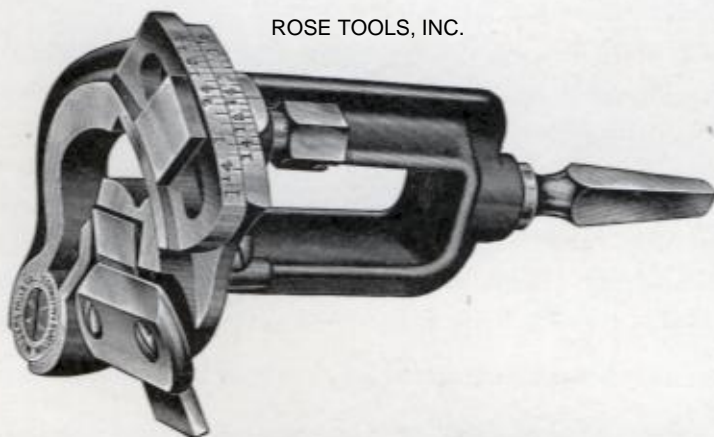

Adjustable to cut tenons from $\frac{1}{4}$ to $1\frac{1}{4}$ inches. Graduated index. Stop gauge to regulate length. Knife carefully tempered and sharpened. Steel adjusting screw. Head castings of malleable iron. Frame enameled black and red. Bright parts polished.

Weight each $\frac{3}{4}$ lb.

Code—Saynd

Price each, \$6.75

(Furnished with $\frac{1}{2}$ inch round shank, if desired, without extra charge.)

Packed one in a box.



BITS AND AUGERS

In 1916 the Millers Falls Company purchased the stock, machinery and good will of the Ford Auger Bit Company of Holyoke, Mass., a company long famed for the excellence of its products, chiefly the Ford single lip auger bit and Ford ship augers.

Since that time we have more than doubled the output, and have added a number of new augers.

Utmost care is used in the making of each bit. Improved machinery, much of it automatic, insure accuracy and uniformity, and for this reason Millers Falls bits and augers are characterized by their well proportioned lips and spurs, keen cutting edges, and deep, clean cut screws.

Inspection is most thorough and none having the least flaw is stamped "Millers Falls".

The variety of styles, sizes and lengths meets all wood boring conditions, both in this country and abroad.



Explanation of Bit and Auger Terms

Bits and Augers are made in a wide range of styles, sizes and lengths.

To facilitate both ordering and requests for quotations, particularly bits and augers of special style and length, we illustrate the principal types with the correct name for each part of the tool.

Reference to these illustrations will avoid any possible misunderstanding and save unnecessary correspondence.

SINGLE TWIST AUGER BIT



SHIP AUGER WITH SCREW

ROSE TOOLS, INC.

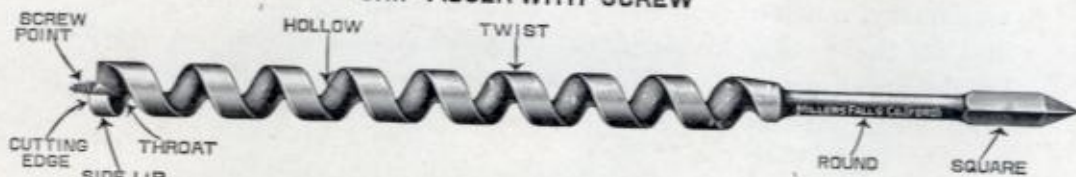

SINGLE TWIST MACHINE BIT





Bit and Auger Heads

The head is the principal working part of a bit. Its formation therefore has much to do with its adaptability for the particular wood to be bored and the type of cut to be made.

The following descriptions of the different heads will be of service in determining the style best suited for any special purpose.



Single Cutter Extension Lip

Single spur and single cutting edge.

Recommended for general all around boring. Rapid, clean cutting and remarkably easy boring. Particularly adapted for difficult boring in wet, green, very hard, or knotty wood, and boring with the grain.

The following stock numbers are made with this head Nos. 531, 533, 551, 431, 231 and 441.



Double Cutter Extension Lip

Two spurs and two cutting edges. Recommended for furniture and cabinet work, or wherever a particularly smooth hole is essential. Bores easily and clears readily.

The following stock numbers are made with this head, Nos. 542, 552 and 5512.



Double Cutter Flat Cut

Especially adapted for boring in very hard woods, particularly those found in Australia and South America. Two cutting edges, two side lips, no spurs.

The following stock numbers are made with this head Nos. 935 and 968.



Single Cutter Ship Head with Screw

Recommended for deep boring or in woods with strong grain. Will stand many sharpenings. Does not bore as smooth a hole as types with spur. Used largely in pneumatic and electric boring machines.

The following stock numbers are made with this head, Nos. 921, 922, 931, 912, 918, 971, 962 and 961.



Single Cutter Ship Head without Screw

This head is especially recommended for deep boring in wet, pitchy woods, or when particularly straight boring is essential. Having no screw has little tendency to follow or drift with the grain of the wood.

Is widely used in pneumatic and electric boring machines.

The following stock numbers are made with this head, Nos. 812, 818, 871 and 861.

ROSE TOOLS, INC.

Boring Speed

The pitch of the screw determines the speed of the bit. It is impracticable to make a different pitch for every kind of boring, so we have adopted certain standards which have been proved best for general work.

Some of our bits have single threads, and some have double, depending upon the size of the bit and the nature of the work for which it is intended.



Auger Bits

No. 531



This auger bit with single spur and single cutting edge cuts with less friction than any other type of auger bit, and is unsurpassed for all around boring.

The side opposite the cutting edge is ground down for clearance. This increases the efficiency of the bit in wet, green, spongy, or knotty woods and in boring with the grain.

The deep, single twist allows maximum clearance for the chips; there is no possibility of its clogging.

The bit cuts a clean, smooth hole, rapidly and accurately; draws in with a minimum of pressure; is easily re-sharpened and bores straight through the wood with but little splintering.

Highly polished overall.

Prices per dozen.

Sizes in sixteenths of an inch.

Size	3	4	5	6	7	8	9
Price	\$6.00	5.00	5.00	5.00	5.00	5.00	6.00
Size	10	11	12	13	14	15	16
Price	\$6.00	7.00	7.00	8.25	8.25	9.50	9.50
Size	17	18	19	20	21	22	24
Price	\$12.00	12.00	14.00	14.00	16.00	16.00	18.00

Code—Babut

Packed one-half dozen in a box.

ROSE TOOLS, INC.

No. 533



Electricians and locksmiths in particular will appreciate this bit.

It requires but six turns to go through one inch of timber—just double the speed of No. 531, and nearly three times as fast as the fine double threaded double lip bits.

Recommended for soft woods only. Highly polished overall.

Made in three sizes only

Prices per dozen.

Sizes in sixteenths of an inch.

Sizes.....	10	11	12
Price.....	\$6.00	7.00	7.00

Code—Bando

Packed one-half dozen in a box.



Auger Bits

No. 542



This is a popular type of Bit, featured by a solid stem extending through the center from the screw-point to the shank. This solid center makes a rigid, strong tool, especially at the point where the shank joins the twist. Has two extension lips and spurs, and two cutting edges. The screw is properly pitched and spurs are of correct proportion for smooth, free cutting. Highly polished over all.

Prices per dozen.

Sizes in sixteenths of an inch.

Size	3	4	5	6	7	8	9	10
Price	\$4.50	4.00	4.00	4.00	4.50	5.00	5.50	6.00
Size	11	12	13	14	15	16	17	18
Price	\$7.00	7.00	8.00	8.00	9.00	9.00	10.50	10.50
Size	19	20	21	22	24			
Price	\$12.00	12.00	13.50	13.50	15.00			

Code—Basco

Packed one-half dozen in a box.

The Correct Way to File a Bit

ROSE TOOLS, INC.

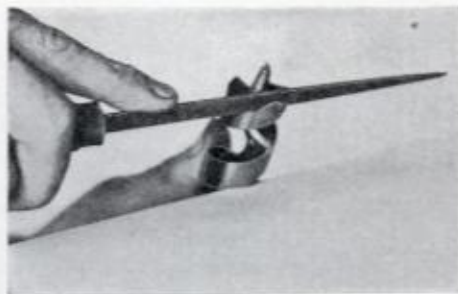

The Spur

Use a fairly smooth mill file. Rest the first twist of the Bit in corner of the bench, spur down, at an angle of about 45° to the bench. Rock the Bit slightly in order to sharpen both front and back of the spur, keeping file always parallel to the bench. Remove as little metal as possible. Never file the outside of spur, as this destroys the clearance and size, and causes Bit to bind.

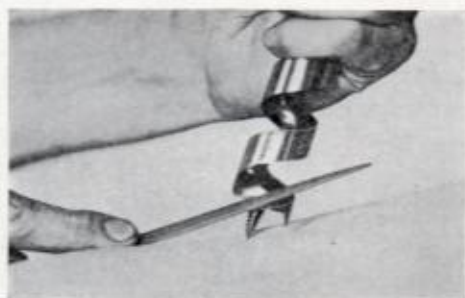

The Cutting Edge

Use same kind of file as on the spur. Hold Bit rigid and in position shown in the illustration. Keep slope of cutting edge as near the original bevel as possible, for if made too steep, the Bit will cut hard. Never file the top of Bit, as this destroys clearance and causes binding.

Auger Bit Sets

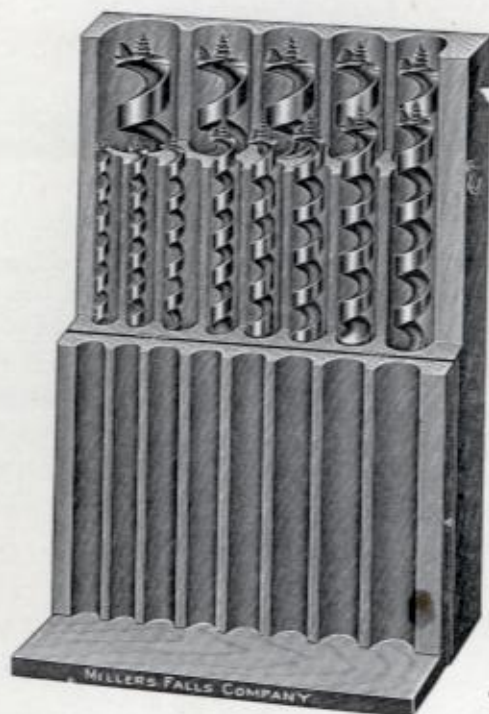

Boxes

A full set of bits is an essential to every carpenter or mechanic. The advantages of a set in a box or roll are many—the danger of rust is reduced, the cutting edges and points are protected from accidental injury, each bit is instantly available, and is always in its proper place.

The Miller Falls box is of seasoned ROSE TOOLS, INC. hardwood, kiln dried and stained; has brass hinges and catch. It is a most durable container, especially convenient for shop and bench work.

How to Order

In ordering prefix figure 1 to type of bit wanted and add the number of quarters. For example: 1531— $32\frac{1}{2}$ quarters signifies a set of $32\frac{1}{2}$ quarters auger bits No. 531. 1542—14 quarters a set of 14 quarters auger bits No. 542.

List prices and assortments.

Quarters	Price	Assortment by sixteenths of an inch.
$32\frac{1}{2}$	\$8.50	4, 5, 6, 7, 8, 9, 10, 11, 12, 13, 14, 15, and 16 one each.
$25\frac{1}{2}$	7.00	4, 5, 6, 7, 8, 9, 10, 11, 12, 14 and 16 one each.
24	6.90	4, 5, 7, 9, 11, and 12 one each and 6, 8, and 10 two each.
$22\frac{1}{2}$	6.80	5, 7, 9, 10, 11, and 12 one each and 4, 6, and 8 two each.
21	6.40	5, 6, 7, 9, 10, 11, and 12 one each and 4 and 8 two each.
$20\frac{1}{2}$	5.90	4, 5, 6, 7, 8, 10, 12, 14 and 16 one each.
$18\frac{3}{4}$	5.50	4, 5, 6, 8, 10, 12, 14 and 16 one each.
18	5.50	4, 5, 6, 7, 8, 9, 10, 11, and 12 one each.
$17\frac{1}{2}$	4.75	4, 6, 8, 10, 12, 14, and 16 one each.
$15\frac{1}{4}$	4.50	4, 5, 6, 8, 10, 12, and 16 one each.
14	4.10	4, 6, 8, 10, 12 and 16 one each.
$11\frac{1}{4}$	3.75	4, 5, 6, 8, 10, and 12 one each.

Code—No. 1531, Bergy

No. 1542, Bezel

Wooden boxes only (without bits) for $32\frac{1}{2}$ quarters (13) bits, each, \$2.40.



Auger Bit Sets



Canvas Rolls

A set of auger bits in a roll is particularly handy for use in portable tool kits as it is more compact than a similar set in a box.

The Millers Falls roll is of heavy, long grām fabricoid—a new material which is absolutely waterproof. Edges are bound with heavy tape, and when closed is securely fastened with a canvas strap. Each bit has an individual pocket, with its respective size plainly stamped across the top.

ROSE TOOLS, INC.

How to Order

In ordering prefix figure 2 to type of bit wanted and add the number of quarters. For example 2531-32½ quarters signifies a set of 32½ quarters auger bits No. 531. 2542-14 quarters a set of 14 quarters auger bits No. 542.

Quarters	Price	Assortment by sixteenths of an inch.
32½	\$8.50	4, 5, 6, 7, 8, 9, 10, 11, 12, 13, 14, 15, and 16 one each.
25½	7.00	4, 5, 6, 7, 8, 9, 10, 11, 12, 14, and 16 one each.
24	6.90	4, 5, 7, 9, 11 and 12 one each and 6, 8 and 10 two each.
22½	6.80	5, 7, 9, 10, 11, and 12 one each and 4, 6, and 8 two each
21	6.40	5, 6, 7, 9, 10, 11, and 12 one each and 4 and 8 two each.
20½	5.90	4, 5, 6, 7, 8, 10, 12, 14, and 16 one each.
18¾	5.50	4, 5, 6, 8, 10, 12, 14, and 16 one each.
18	5.50	4, 5, 6, 7, 8, 9, 10, 11, and 12 one each.
17½	4.75	4, 6, 8, 10, 12, 14, and 16 one each.
15¾	4.50	4, 5, 6, 8, 10, 12, and 16 one each.
14	4.10	4, 6, 8, 10, 12, and 16 one each.
11¾	3.75	4, 5, 6, 8, 10, and 12 one each.

Code—No. 2531, *Bedim*

No. 2542 *Basfy*

Canvas rolls only (without bits) for 32½ quarters (13 bits) each, \$1.00.



Ship Auger Bits

New

No. 935



Recommended particularly for the hard tropical woods and is especially tempered for such woods. Screw-point has deep thread with moderately coarse feed. A splendid bit for boring cross or end grain domestic hard woods. Is easily resharpened.

	Prices per dozen.			Sizes in sixteenths of an inch.				
Size	3	4	5	6	7	8	9	10
Price	\$4.50	4.00	4.00	4.00	4.50	5.00	5.50	6.00
Size	11	12	13	14	15	16	18	20
Price	\$7.00	7.00	8.00	8.00	9.00	9.00	10.50	12.00
Size	22	24						
Price	\$13.50	15.00						

Code—Baust

Packed one-half dozen in a box.

ROSE TOOLS, INC.

Ship Auger Bit

No. 931



A sturdy bit built for rough usage, especially recommended for boring hard, knotty, and end grain woods. Has coarse, deep cut, single threaded screw, and sharp, well-proportioned side lip. Will stand many resharpenings.

	Prices per dozen.			Sizes in sixteenths of an inch.				
Sizes	4	5	6	7	8	9	10	
Price	\$6.00	6.00	6.00	6.00	6.00	7.50	7.50	
Sizes	11	12	13	14	15	16		
Price	\$9.00	9.00	10.50	10.50	12.00	12.00		

Code—Basal

Packed one-half dozen in a box.

Single Lip Car Bits (Ford)

No. 551



12" Twist 18" Overall

This bit has all the features of No. 531 auger bit as it is identical with it except for the length of twist and length overall.

Positively will not clog even when bored to its extreme depth. Highly polished overall.

Prices per dozen.

Sizes in sixteenths of an inch.

Size	4	5	6	7	8	9	10	11
Price	\$11.25	11.25	11.25	11.25	11.25	12.50	13.75	15.00
Size	12	13	14	15	16	18	20	
Price	\$16.25	17.50	19.00	20.50	22.00	26.00	30.00	

Code—Baoba

Packed one-half dozen in a box up to and including 16/16 in.

Packed one-fourth of a dozen in a box above this size.

Solid Center Car Bit

No. 552



12" Twist 18" Overall

This bit is identical with No. 542 auger bit except for the length of twist, and length overall. Highly polished overall.

Prices per dozen.

Sizes in sixteenths of an inch.

Size	4	5	6	7	8	9	10
Price	\$9.00	9.00	9.00	10.00	11.25	12.50	13.75
Size	11	12	13	14	15	16	18
Price	\$15.00	16.25	17.50	19.00	20.50	22.00	26.00
Size	20	22	24				
Price	\$30.00	34.00	38.00				

Code—Barba

Packed one-half dozen in a box up to and including 16/16 in.

Packed one-fourth of a dozen in a box above this size.



Ship Auger Car Bit (Ford)

No. 922



12" Twist 18" Overall

This type of bit without spur is made especially for boring in rough timber, and in woods with a firm grain. Cuts easily and expels chips freely to the full depth of the twist.

16/16 in. and smaller have full polished twist and round. Larger sizes have black hollows.

	Prices per dozen.			Sizes in sixteenths of an inch.			
Size	4	5	6	7	8	9	10
Price	\$11.00	11.00	11.00	11.00	11.00	11.00	11.00
Size	11	12	13	14	15	16	17
Price	\$12.00	12.00	13.00	13.00	14.50	14.50	16.00
Size		18	20	22	24		
Price		\$16.00	18.00	20.00	23.00		

Code—Baret

Packed six in a box up to and including 16/16 in.

Packed three in a box above this size.

ROSE TOOLS, INC.

Ship Auger Car Bit (Ford)

No. 921



8" Twist 12" Overall

Differs from No. 922 only in length of twist and length overall.

It is made especially for certain car shop and other work where the 12 in. twist is unnecessarily

long.

	Prices per dozen.		Sizes in sixteenths of an inch.			
Size	6	7	8	9	10	11
Price	\$10.00	10.00	10.00	10.00	10.00	11.00
Size	12	13	14	15	16	
Price	\$11.00	12.00	12.00	13.50	13.50	

Code—Barqu

Packed six in a box.



Ship Augers (Ford) No. 912



With Screw

Ship Augers are generally used in a wooden auger handle or by means of a metal crank or handle welded to the taper shank.

The twists vary in length according to the size of the auger. Up to and including 16/16 in. have full polished twists and rounds. Larger sizes have black hollows.

4-5/16	8" twist 13" overall
6-7-8/16	10" twist 14" overall
9/16-16/16	12" twist 18" overall
17/16 up	15" twist 20" overall

Prices per dozen. Sizes in sixteenths of an inch.

Size	4-10	11	12	13	14	15	16	17
Price	\$11.00	12.00	12.00	13.00	13.00	14.50	14.50	16.00
Size	18	19	20	21	22	23	24	25
Price	\$16.00	18.00	18.00	20.00	20.00	23.00	23.00	27.00
Size	26	27	28	29	30	31	32	34
Price	\$27.00	32.00	32.00	38.00	38.00	45.00	45.00	57.00
Size	36	38	40	42	44	46	48	
Price	\$72.00	86.00	101.00	115.00	130.00	144.00	158.00	

Code—Barne

No. 812



ROSE TOOLS, INC.

Without Screw

Identical with No. 912 except has no screw point. Sometimes called "barefoot" augers. Recommended where particularly straight boring is essential, because it will not drift off with the grain of the wood.

Prices per dozen. Sizes in sixteenths of an inch.

Size	4	5	6	7	8	9	10	11
Price	\$13.20	13.20	13.20	13.20	13.20	13.20	13.20	14.40
Size	12	13	14	15	16	17	18	19
Price	\$14.40	15.60	15.60	17.40	17.40	19.20	19.20	21.60
Size	20	21	22	23	24	25	26	27
Price	\$21.60	24.00	24.00	27.60	27.60	32.40	32.40	38.40
Size	28	29	30	31	32	34	36	38
Price	\$38.40	45.60	45.60	54.00	54.00	68.40	86.40	103.20
Size	40	42	44	46	48			
Price	\$121.20	138.00	156.00	172.80	189.60			

Code—Baron

Packed one-half dozen in box up to and including 16/16 in.

Packed one-fourth of a dozen in box from 17/16 to 30/16 in. inclusive.

Wrapped singly in heavy paper above this size.



Ship Augers (Ford)

No. 918



18" Twist 24" Overall

This auger is used principally in dock and bridge work, where a boring depth of 20 to 22 inches is required. All sizes have black hollows.

	Prices per dozen.		Sizes in sixteenths of an inch.				
Size	8	9	10	11	12	13	14
Price	\$15.00	16.50	18.00	19.50	21.00	22.80	24.60
Size	15	16	17	18	19	20	
Price	\$26.40	28.20	30.00	31.80	33.60	35.40	

Code—Basha

Eighteen in. twist augers packed one-half dozen in box up to and including 16/16 in.

From 17/16 to 20/16 in., packed one-fourth of a dozen in box.

Special shanks can be welded onto these augers to give any desired length overall. Prices upon request.

ROSE TOOLS, INC.

No. 818



Without Screw

The same auger as No. 918 except has no screw point.

	Prices per dozen.		Sizes in sixteenths of an inch.			
Size	8	9	10	11	12	
Price	\$18.00	19.80	21.60	23.40	25.20	
Size	13	14	15	16	17	
Price	\$27.30	29.50	31.70	33.80	36.00	
Size	18	19	20			
Price	\$38.40	40.30	42.50			

Code—Basix

Special shanks can be welded onto these augers to give any desired length overall. Prices upon request.



Ring Ship Augers (Ford)

No. 961



With Screw

This type of auger is used chiefly in dock and bridge construction. Operated with a wooden or iron handle. Rings are cast and firmly riveted to the shank.

Length of twist is the same as No. 912 ship augers. Overall length 18 to 24 inches in proportion to size of auger.

Prices per dozen. Sizes in sixteenths of an inch.

Size	10 (and under)	11 and 12	13 and 14	15 and 16	17 and 18
Price	\$15.10	16.20	17.30	18.95	20.60
Size	19 and 20	21 and 22	23 and 24	25 and 26	27 and 28
Price	\$22.80	25.00	28.30	32.70	38.20
Size	29 and 30	31 and 32	34	36	38
Price	\$44.80	52.50	62.70	79.20	94.60
Size	40	42	44	46	48
Price	\$111.10	126.50	143.00	158.40	173.80

Code—Basil

Wrapped three in a paper and six in a package up to and including 16/16 in. Above this size, three in a package.

No. 861

ROSE TOOLS, INC.



Without Screw

Identical with No. 961 except has no screw.

Prices per dozen. Sizes in sixteenths of an inch.

Size	10 (and under)	11 and 12	13 and 14	15 and 16	17 and 18
Price	\$18.10	19.40	20.75	22.75	24.70
Size	19 and 20	21 and 22	23 and 24	25 and 26	27 and 28
Price	\$27.35	30.00	33.95	39.25	45.85
Size	29 and 30	31 and 32	34	36	38
Price	\$53.73	63.00	75.25	95.05	113.50
Size	40	42	44	46	48
Price	\$133.30	151.80	171.60	190.10	208.55

Code—Basqu

Wrapped six in a package up to and including 16/16 in. Above this size, three in a package.



Solid Center Ring Augers

No. 5512



Extension Lip Head

12" Twist 24" Overall

Head same as No. 542 Auger Bit.

Cast rings firmly riveted to shank. Polished twist and round.

Prices per dozen.

Sizes in sixteenths of an inch.

Size	6	7 and 8	9 and 10	11 and 12	13 and 14
Price	\$10.00	11.00	12.00	13.00	14.00
Size	15 and 16	18	20	22	24
Price	\$15.00	16.50	18.25	20.00	22.75

Code—Bayis

One-quarter of a dozen in a package, wrapped in heavy paper.

Cuban Ring Augers

ROSE TOOLS, INC.

No. 968

New



This auger has a deep cut thread, two cutting edges and two side lips.

It is used in boring against the grain or in hard wood, particularly of the tropical variety.

Twist is full polished, shank enameled red. Cast rings firmly riveted to shank.

Twist $4\frac{1}{2}$ to $5\frac{1}{2}$ inches long. Overall length 16 to 22 inches long, depending upon the size of the auger.

Prices per dozen.

Sizes in sixteenths of an inch.

Size	5-6-7-8-10	12	14	16	18	20	22	24
Price	\$12.00	13.00	14.00	15.00	16.50	18.25	20.00	22.75

Code—Bicub

One-quarter of a dozen in a package, wrapped in heavy paper.



Rafting Augers

No. 962



12"-15" Twist 30" Overall

This auger is used chiefly for heavy, deep boring, such as log rafts, booms, etc. Has the same style of twist as No. 912 ship auger. The shank is fitted with cast ring. Black hollows and round. Polished edges.

Prices per dozen.

Sizes in sixteenths of an inch.

Size	1 $\frac{1}{4}$	1 $\frac{1}{2}$	1 $\frac{3}{4}$	2
Price	\$32.00	40.00	48.00	56.00
Size	2 $\frac{1}{4}$	2 $\frac{1}{2}$	2 $\frac{3}{4}$	3
Price	\$66.00	76.00	90.00	105.00

Code—Bayto

Wrapped singly in heavy paper.

Boring Machine Augers

No. 231



8" Twist 12" Overall

ROSE TOOLS, INC.

These augers are for use in hand boring machines as shown on page 45. Cuts smoothly, rapidly and will not bind or choke. Full polished overall.

Prices per dozen.

Sizes in sixteenths of an inch.

Size	6	7	8	9	10	11	12	13
Price	\$10.00	10.00	10.00	10.00	10.00	11.00	11.00	13.00
Size	14	16	18	20	22	24	28	32
Price	\$13.00	15.00	17.00	19.00	21.00	24.00	28.00	32.00

Code—Bayou

All sizes wrapped three in a package.

Augers in Sets

Price, per set	18 \$6.00	23 7.50	41 quarters 13.50
Size	1, 1 $\frac{1}{2}$, 2 in.	1, 1 $\frac{1}{4}$, 1 $\frac{1}{2}$, 2 in.	$\frac{1}{2}$, $\frac{5}{8}$, $\frac{3}{4}$, $\frac{7}{8}$, 1, 1 $\frac{1}{4}$, 1 $\frac{1}{2}$, 1 $\frac{3}{4}$, 2 in.
Code	Derni	Derik	Dervi

MILLERS FALLS COMPANY



Power Machine Bits

No. 431



Single Twist—Extension Lip

Code—Baset

The following lengths and sizes are carried in stock.

6 in. Twist	4-18/16 inc. 20, 22, 24/16
8, 10, and 12 in. Twist ..	6-18/16 inc. 20, 22, 24/16
14 in. and 16 in. Twist ..	8-18/16 inc. 20, 22, 24/16

No. 971



Ship Auger Head—With Screw

Code—Baton

No. 871



Without Screw

Code—Bayle

The following sizes are carried in stock:

4½ inch Twist	8/16 to 16/16	15 inch Twist	17/16 to 48/16
8 inch Twist	8/16 to 16/16	18 inch Twist	8/16 to 20/16
12 inch Twist	8/16 to 24/16	Other lengths forged special to order.	

Prices per dozen.

Sizes in sixteenth of an inch.

Prices are for Nos. 431 and 971—for 871 add twenty per cent.

Size 16th in.	4½ and 6 in. twist	8 in. twist	10 in. twist	12 in. twist	14 in. twist	15 in. and 16 in. twist	18 in. twist
8 and under	\$10.80	\$12.96	\$15.12	\$17.28	\$19.44	\$21.60	\$23.76
9	12.00	14.40	16.80	19.20	21.60	24.00	26.40
10	13.20	15.84	18.48	21.12	23.76	26.40	29.04
11	14.40	17.28	20.16	23.04	25.92	28.80	31.68
12	15.60	18.72	21.84	24.96	28.08	31.20	34.32
13	16.80	20.16	23.52	26.88	30.24	33.60	36.96
14	18.00	21.60	25.20	28.80	32.40	36.00	39.60
15	19.20	23.04	27.00	30.72	34.56	38.40	42.24
16	20.40	24.48	28.56	32.64	36.72	40.80	44.88
17	21.60	25.92	30.24	34.56	38.88	43.20	47.52
18	22.80	27.36	31.92	36.48	41.04	45.60	50.16
19	24.00	28.80	33.60	38.40	43.20	48.00	52.80
20	25.20	30.24	35.28	40.32	45.36	50.40	55.44
21	26.40	31.68	36.96	42.24	47.52	52.80
22	27.60	33.12	38.64	44.16	49.68	55.20
23	46.08	51.84	57.60
24	30.00	36.00	42.00	48.00	54.00	60.00
25	63.00
26	66.00
27	69.00
28	72.00
29	75.00
30	78.00
31	81.00
32	84.00
34	91.20
36	98.40
38	105.60
40	112.80
42	121.20
44	129.60
46	138.00
48	146.40

ROSE TOOLS, INC.

Unless otherwise specified, shanks are furnished ½ in. by 2 in.

Straight shanks of any diameter not exceeding 3 in. in length furnished without extra charge.

For shanks exceeding 3 in. in length an extra charge of three cents per inch net is made.

Morse and special taper shanks quoted on application.

Bit Gauges

No. 2

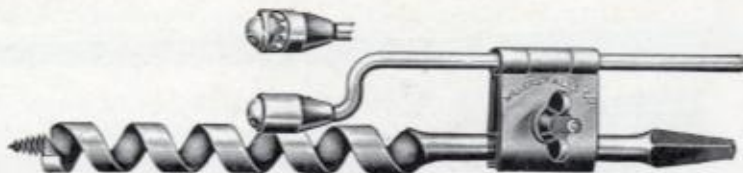

By the use of this tool any number of holes can be bored to a uniform depth. It clamps to shank of any size auger bit, and tightens on the bit and gauge spindle at the same time. Contact ball revolves on ball bearings which reduces friction to a minimum and prevents defacing the most delicate material.

Length $5\frac{3}{4}$ inches.

Nickel plated.

Steel set screw.

Weight each, 2 oz.

Price each, \$.50

Code—*Apiti*

Packed six in a box.

No. 1



This gauge clamps to shank of bit the same as No. 2, but is without contact ball. For this reason is recommended for common work only.

Length $4\frac{3}{4}$ inches.

Polished.

Steel set screw.

Weight each, 2 oz.

Price each, \$.35

Code—*Awary*

Packed six in a box.

No. 36



This gauge is clamped to the twist of the bit and securely held by two thumb screws. Two smooth shoes prevent marring the work.

Length 2 inches.

Nickel plated.

Steel set screws.

Weight each, 3 oz.

Price each, \$.40

Code—*Awasa*

Packed six in a box.



Bit Extensions

No. 35

Improved



Follows 11/16 bit or larger. Not recommended for Bits larger than 12/16, although is of ample strength to turn a 7/8 bit.

Having but two jaws allows extra wide surface to withstand twisting strain.

Print in jaws conforms to shape of auger bit shank, perfect alignment, no wobbling.

Jaws are removable. Easily and quickly replaced. One piece socket and shank.

Adjusting nut heavily knurled. Gives positive grip. Threaded for rapid adjustment. Upper portion of adjusting nut of hex stock to permit tightening with wrench.

Jaws drop forged. Chuck shell of extra heavy steel tubing. Polished overall.

Lengths	12 in.	15 in.	18 in.	21 in.	24 in.	30 in.
Weight, each	10 oz.	11 oz.	13 oz.	14 oz.	16 oz.	18 oz.
Price	\$2.10	2.20	2.25	2.30	2.35	2.50
Code	Cabin	Cabos	Cabio	Cacko	Caddy	Caden

(Extra jaws per pair .35c.)

Packed one in a box.

No. 5



Designed to follow a 5/8 in. bit or larger into its bore, but should not be used with bits over 1 1/8. Bits are inserted and released easily and quickly. The chuck is made of a special tool steel unsurpassed for strength and toughness. The jaws are tempered, and hold the bit securely.

The socket is screwed and pinned to the rod. Shearing strain is overcome by pinning off center.

The knurled nut is made extra long to give a firm grip. Polished overall.

Length	12 in.	15 in.	18 in.	21 in.	24 in.	30 in.
Weight, each	9 oz.	10 oz.	12 oz.	13 oz.	15 oz.	17 oz.
Price, each	\$2.00	2.05	2.10	2.20	2.25	2.35
Code	Campo	Canal	Canor	Candi	Caney	Canon

Packed one in a box.

No. 4



Follows bits 3/4 in. or larger into their bores. Bit shank is inserted into solid socket through side opening and then made fast by turning down the shell, so shank is held between an inner socket and lip of outer sleeve. Bits can be inserted or removed quickly and easily. This is an exceptionally strong tool. Should not be used with bits over 13/16 in. in diameter. Polished finish.

Length	15 in.	18 in.	21 in.	24 in.
Weight, each	15 oz.	17 oz.	1 1/4 lbs.	1 3/8 lbs.
Price, each	\$2.35	2.45	2.55	2.60
Code	Caldo	Calic	Calip	Calki

Packed one in a box.



Bit Extensions No. 11



This is a neat, strong extension, of the solid socket type.

The shell and knurled nut are made of seamless steel tubing, the socket and shank of cold rolled steel. Shank is forced into socket and pinned.

Coarse thread on nut holds securely and works rapidly. Polished overall. Follows an 11/16 bit or larger, but not recommended for bits larger than 12/16.

Length.....	15 in.	18 in.	24 in.
Weight, each.....	12 oz.	15 oz.	20 oz.
Price, each.....	\$2.20	2.25	2.35

Code 15 in.—Cambe

Code 18 in.—Camel

Code 24 in.—Camis

Packed one in a box.

No. 1



A heavy, rugged extension designed especially for work requiring bits larger than 12/16. Has master chuck of same construction as that used on Millers Falls Braces. Holds any bit from the smallest to the expansive type. Chuck is screwed and soldered to rod. Shank is forged down to give brace or breast drill jaws a better grip. Outside diameter of chuck 1½ inch. Polished overall. Unexcelled for plumbers' and millwrights' use.

Length.....	ROSE TOOLS, INC.	18 in.	24 in.
Weight, each.....		1¾ lbs.	2¼ lbs.
Price, each.....		\$2.25	2.40

Code 18 in.—Cache

Code 24 in.—Cactu

Packed one in a box.

No. 6



Extensible type which makes it unnecessary to carry extensions of different lengths. The outer sleeve telescopes over the inner spindle and engages it at intervals of 1½ inch, as desired, Chuck is the same as on No. 5 extension.

Length collapsed, 16½ in.

Length extended to extreme, 24 in.

Weight each, 17 oz.

Price each, \$4.40

Code—Canis

Packed one in a box.



Ratchet Auger Handle

No. 4

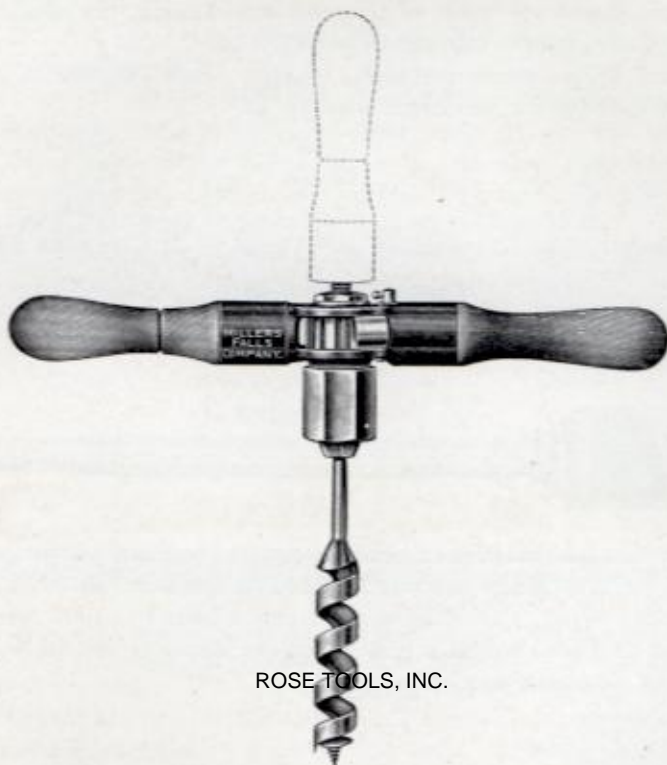

ROSE TOOLS, INC.

The feature of this handle is its ratchet construction—operating both to right and left by means of small lever. This permits its working effectively in close corners and other awkward places.

Steadying handle is detachable and can be attached to top as illustrated. Handle can be locked and used without ratchet if desired.

Chuck holds practically all sizes of bit and auger shanks.

Hardwood handles. Metal parts japanned. Metal trimmings nickeled.

Length 15 inches.

Weight each, $2\frac{3}{4}$ lbs.

Price each, \$4.30

Code—Cages

Packed one in a box.



Auger Handles

No. 3



A light, yet strong handle. Single set screw. Tightening on malleable casting holds securely all ordinary bit and auger shanks. Hardwood handles. Frame japanned black.

Length 16 inches

Weight each, 1¼ lbs.

Price each, \$1.30

Code—Cagil

Packed three in a box.

No. 03



Identical with No. 3 except that it has two set screws.

Length 16 inches

Weight each, 1¼ lbs.

Price each, \$1.15

Code—Cagil

ROSE TOOLS, INC.

Packed three in a box.

No. 2



A stout hardwood handle. Augers are held by two 3-in. steel clamps, which open wide enough to admit all sizes of bit and all except the largest sizes of ship auger shanks. Clamps securely held by two set screws.

Length 17 inches

Weight each, 1¼ lbs.

Price each, \$.90

Code—Cagne

Packed six in a box.

Sill Borer or Joist Tool No. 52

(Ratchet)

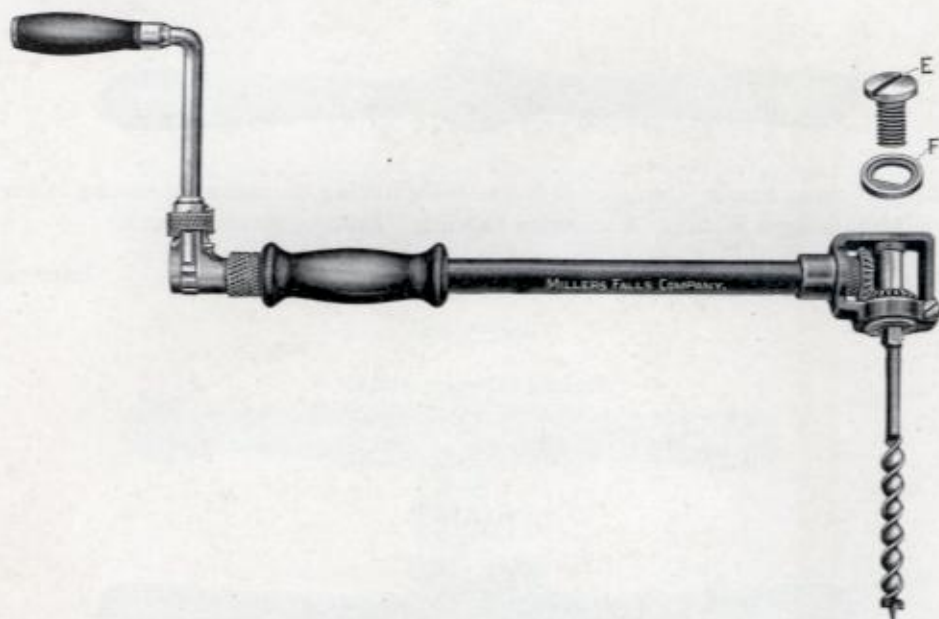

This tool is indispensable to car builders, electricians and others who have a great deal of special boring to do, particularly at right angles in cramped places.

The distinguishing feature of the tool is the short head $2\frac{3}{8}$ inches only in depth, which permits its use in narrow spaces.

ROSE TOOLS, INC.

The crank with sweep of twelve inches, and ratchet operating either to right or left, affords ample power for hard boring. Made for wood boring only.

Figures E and F show patent cup washer which cannot work loose.

Specifications

Length 23 inches. Depth of head $2\frac{3}{8}$ inches.

Chuck—holds bit shanks only.

Gears, bushings and other working parts of hardened steel.

Ball bearings.

Take up nuts for possible wear on bearings.

Head equipped with patent cup washer and screw which keep spindle from working loose.

Frame malleable iron, japanned.

Other metal parts japanned.

Steadying handle stained hardwood.

Weight each, $4\frac{3}{4}$ lbs.

Price each, \$6.50

Code—Aggra

Packed one in a box.



Sill Borers or Joist Tools

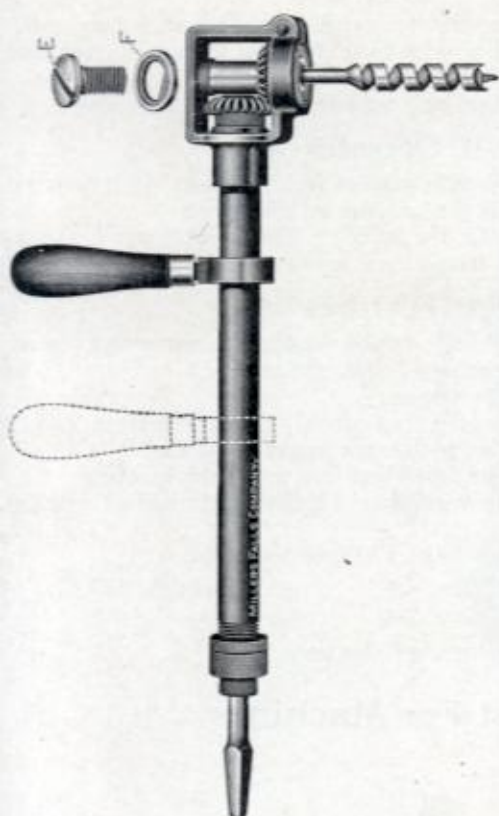

No. 51

No. 51

The head of this tool is identical with, and operates the same as No. 52. The frame instead of having crank and ratchet has a shank fitted for use with bit brace or breast drill.

Specifications

Working parts, except as noted above, same as No. 52.

Adjustable steadying handle.

Length 16½ inches.

Weight each, 3 lbs.

Price each, \$5.30

Code—Agreg

Packed one in a box.

ROSE TOOLS, INC.

No. 54

The same as No. 51, except is 8¼ inches long.

Weight each, 2 lbs.

Price each, \$5.10

Code—Agran

Packed one in a box.

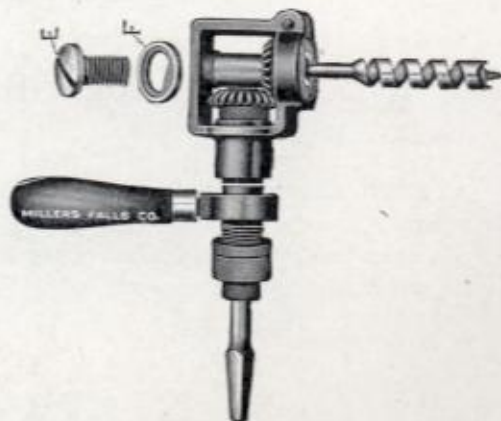

No. 54



Electrician's Boring Machine

No. 144

This machine is primarily for electricians use, although it is frequently used by carpenters and millwrights, who have occasion to bore in overhead joists.

It is rapid acting and will soon pay for itself in actual time saved.

How it Operates

The head is equipped with a double ratchet which forces the bit forward *continuously* as the operator pulls the handles up and down.

The *quicker the pull, the faster the boring.* This double ratchet construction is patented. It is not found in any other machine.

Special Features

Head less than three inches thick—can be used in the narrowest places.

Interchangeable hardened bearings—runs frictionless.

Bits will clear without reverse motion.

Standard of two tempered steel tubes quickly adjustable from 7 to 12 feet. Can be lengthened to 16 feet with extra length of tubing.

One each 10 and 11/16 in. bits furnished free with each machine.

Below boring attachment for work in old buildings furnished without extra charge.

Steel sprockets. Strong steel chain. Hardwood handles.

Weight boxed 40 lbs., net 18 lbs.

Price each, \$33.45

Code—Cural

Packed one in a wooden case.



Foot Rest For Machines

New

ROSE TOOLS, INC.



Illustration shows foot rest which is fastened to the base of the machine by a set screw. Standing squarely on this rest affords a means of further steadying the tool, particularly when used at its extreme height.

Weight each, 3 lbs.

Code—Curax

Price each, \$1.25

Auger Bit For Machine

No. 441

This bit is made specially for the No. 144 machine and cannot be purchased at hardware stores in general.

It has a hole drilled in the end of round shank to take cotter pin which holds bit in the machine.

Carried in stock in three sizes with 4½ in. twist, 7½ in. overall. Sizes and prices per dozen.

10/16 in.

\$6.00

11/16 in.

7.00

12/16 in.

7.00

Code—Cucek

Packed one-half dozen in a box.



Boring Machine

No. 145

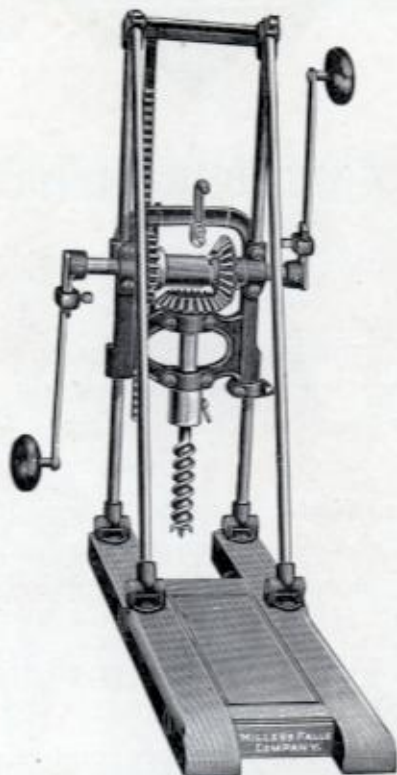

ROSE TOOLS, INC.

An improved machine made especially for carpenters. Used largely for house framing, boring railroad ties, and other boring where speed and large capacity are essential.

Specifications

- Bores vertically or at any angle within an arc of 50 degrees.
- Frame locks automatically at topmost point—released by thumb latch.
- Raises automatically by turning handles as in boring.
- Adjustable cranks regulate speed and power.
- Boring depth 12 inches. Made to order for greater depths.
- Spindle cranks, uprights and angle rods of steel. Wood bottom board.
- Steel and machined parts polished, other metal parts japanned.
- Handles stained hardwood.

Height 25 in.

Weight boxed 45 lbs., net 28 lbs.

Price (without augers), \$20.20

Code—Cobor

For list prices of augers see page 35.

Packed one in a wooden case.



HAND AND BREAST DRILLS

Marked improvements have been made in Millers Falls hand and breast drills the past few months.

Chucks on several hand drills have been increased from 3-16 to 1-4 in. capacity and changed to the improved protected spring type. The speed change on six numbers of breast drills has been improved and simplified. Today the drills are a greater value than ever.

Chucks—The inner construction of the Millers Falls chuck is of particular note. The jaws are opened and closed by springs situated in the base of the chuck, in such a position that it is impossible to get the drill in back of them. They cannot be jammed or knocked out.

This chuck is used on all breast drills and on all hand drills with the exception of Nos. 4 and 4D.

The design of the chuck shells gives a more comfortable hand grip in tightening.

Gears and Pinions—The gears are made from close grained grey iron. The pinions are steel. Both have cut teeth. This insures smooth running and long wear.

Frames—Malleable iron and steel accurately machined. The former are heavily enameled a glossy black and the latter polished and nicked.

Handles—Handles are made from the finest tropical and native hard woods and are highly polished. They are turned in our own woodworking shop and are designed for appearance as well as for strength.

Finish—All our hand and breast drills are now made with an improved finish. The large gears are enameled a rich red by a new process which imparts a velvet-like smoothness. On each breast drill gear is placed a decalomania showing our name and trade mark. The hand drill handle bears our trade mark in colors by means of a transfer sticker.

Millers Falls drills now combine quality and appearance as never before. There is a size and type for every drilling purpose and to suit every individual fancy.

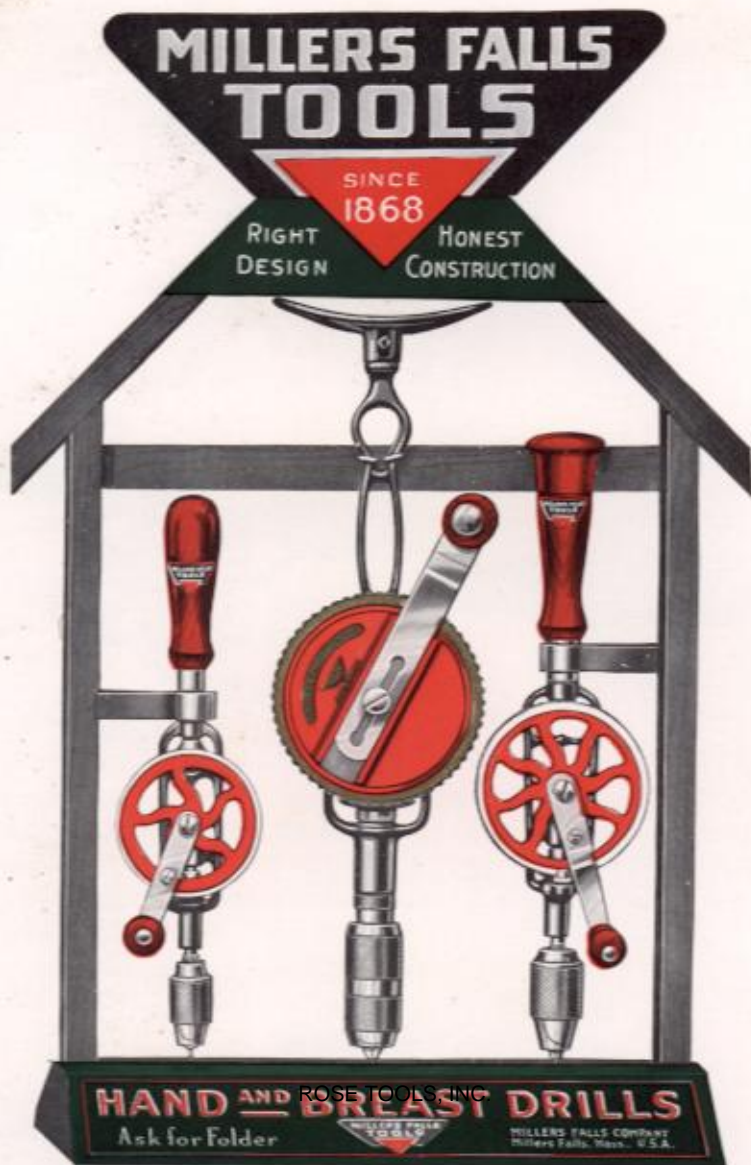

HAND AND BREAST DRILL DISPLAY, No. 400

A brand new idea in drill display, which will increase your drill turnover. Placed in your window or on the counter, it is sure to create a desire in the minds of your customers to own a hand or breast drill.

This display which holds one No. 12 Breast Drill and one each No. 2 and No. 5 Hand Drills, is given to you free of charge with an order for the following:

4—No. 12 Breast Drills 4—No. 2 Hand Drills 4—No. 5 Hand Drills

One hundred leaflets "A Guide to Good Drills" supplied with each display.

SPECIFICATIONS

Height—26½ inches to top of Trade Mark.

Width—15½ inches.

Depth—8 inches. Metal Base, rubber tipped. Frame of Wood. Metal Trade Mark.

Three Compartments in Base for Folders. Illustration shows actual colors.

Weight with three Drills—13 lbs. Code—Dridi Shipping weight with one dozen drills, 80 lbs.

EACH FIXTURE PACKED IN AN INDIVIDUAL CARTON.

Hand Drill (Ratchet)

No. 1980

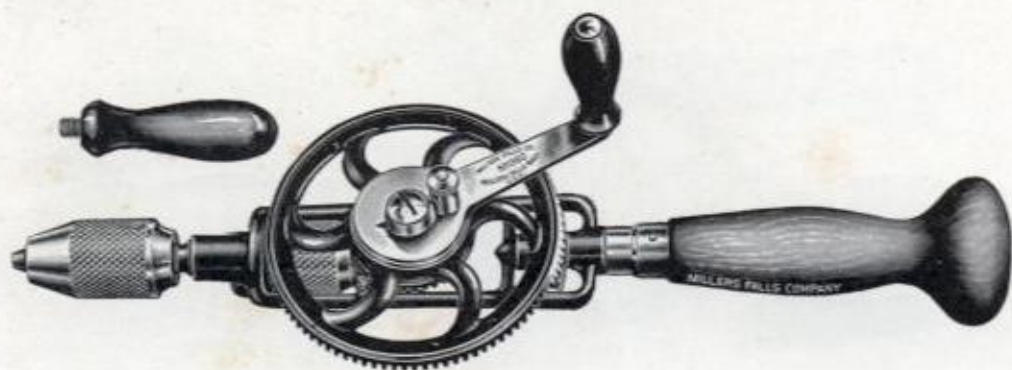
Improved

Because of its size and chuck capacity this drill frequently serves every drilling purpose. The mushroom shaped handle comfortably fits the hand and rests easily against the body. The ratchet is rapid, easily operated, and permits working in places inaccessible with the ordinary hand drill.

Speed is instantly changed by rotating knurled sleeve on spindle. Both speed and ratchet can be shifted without removing drill from the work.

Specifications

Ratchet—left or right operated by cap or **ROSE TOOLS, INC.**

Two speeds—gear ratios $1\frac{1}{2}$ to 1 and 4 to 1.

Chuck—three jaw; improved protected springs; capacity 0-3/8 in. round shank drills.

Cut Gears.

Pinions—steel, cut teeth, enclosed for protection.

Idler gear to counteract outward thrust of large gear.

Ball thrust bearing on spindle.

Solid end main handle.

Side handle removable. Both of stained hardwood.

Frame—malleable iron, enameled black.

Large gear, enameled red. Other metal parts nickered.

Length $15\frac{3}{4}$ inches.

Weight each, $3\frac{1}{4}$ lbs.

Price each, without drills, \$6.20

Code—Dabak

Packed one in a box.



Hand Drills

No. 980

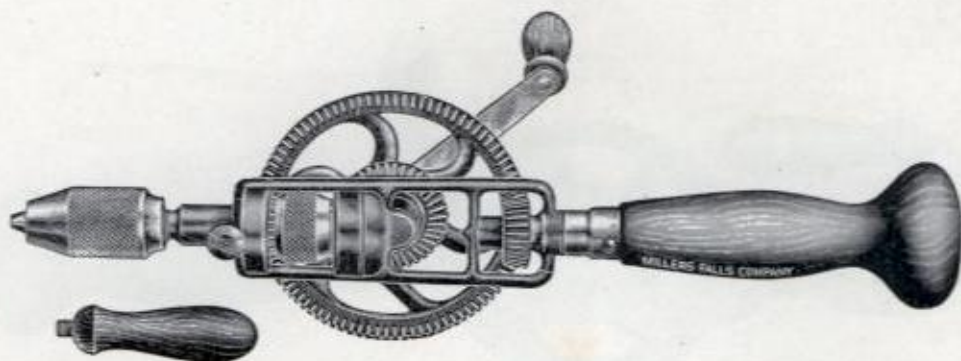
Improved

This drill is identical with No. 1980 except that it does not have the ratchet action.

The convenience of the speed shifter on both of these drills will be particularly appreciated when it is necessary to slow up quickly from high speed. A half turn on the knurled barrel changes the speed within a fractional part of a revolution and without removing the drill from the work.

Specifications

Two speeds—gear ratios $1\frac{1}{2}$ to 1 and $2\frac{1}{2}$ to 1.

Chuck—three jaw; improved protected springs; capacity $0\text{-}\frac{3}{8}$ in. round shank drills.

Cut gears.

Pinions—steel, cut teeth, enclosed for protection.

Idler gear to counteract outward thrust of large gear.

Ball thrust bearing on spindle.

Solid end main handle.

Side handle removable. Both of stained hardwood.

Frame—malleable iron, enameled black.

Large gear enameled red. Other metal parts nickered.

Length $15\frac{3}{4}$ inches.

Weight each, $3\frac{1}{8}$ lbs.

Price each, without drills, \$5.00

Code—Dacek

Packed one in a box.



Hand Drills

No. 2

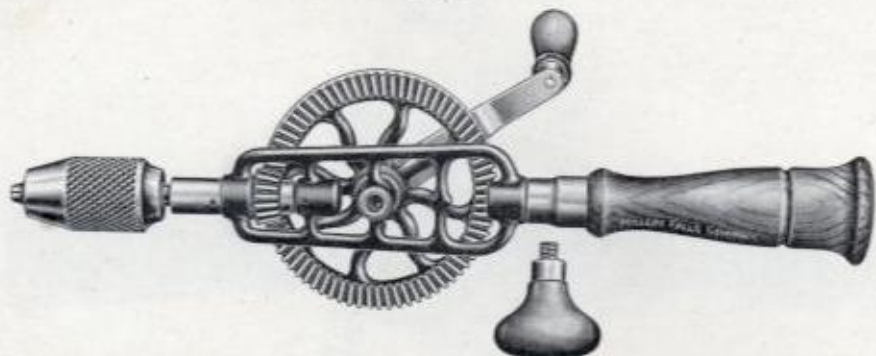

A strong, serviceable tool. The flat end on main handle rests comfortably against the body for hard drilling.

Chuck—three jaw. Improved protected springs. Capacity 0- $\frac{3}{8}$ in., round shank drills.

Single speed gear ratio 4 $\frac{1}{2}$ to 1. Ball thrust bearing. Cut gears.

Steel pinion and gear stud.

Adjustable friction roll to equalize bearings. Side handle detachable.

Hollow end main handle of cocobolo containing eight wood boring points.

Malleable iron frame, enameled black. Large gear nicked and enameled red. Other metal parts nicked.

Length 14 $\frac{1}{2}$ inches.

Weight each, 2 $\frac{1}{2}$ lbs.

Price each (including points), \$4.50

Code—Dager

Packed one in a box.

No. 2D

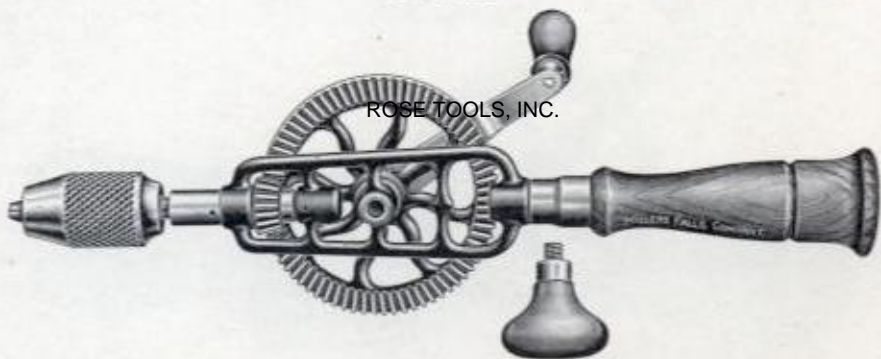

ROSE TOOLS, INC.

The same as No. 2 except is equipped with six twist drills for metal drilling, instead of the wood boring points.



Sizes, $\frac{1}{8}$ in., $\frac{5}{32}$ in., $\frac{3}{16}$ in., $\frac{7}{32}$ in., $\frac{1}{4}$ in., $\frac{9}{32}$ in.

Price each (with drills), \$5.35

Weight each, 2 $\frac{1}{2}$ lbs.

Code—Daest

Packed one in a box.



Hand Drills

No. 2B

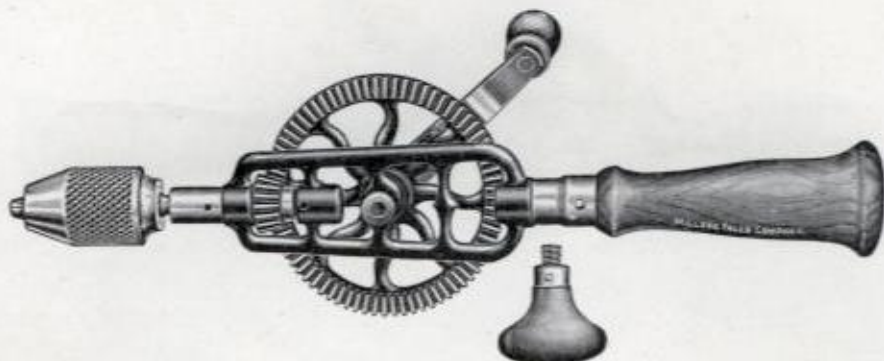

The same drill as No. 2 except that the main handle is solid and both main and crank handles are of native hardwood.

Length 14½ inches.

Weight each, 2¼ lbs.

Price each (without drills), \$4.00

Code—Dagot

Packed one in a box.

No. 7

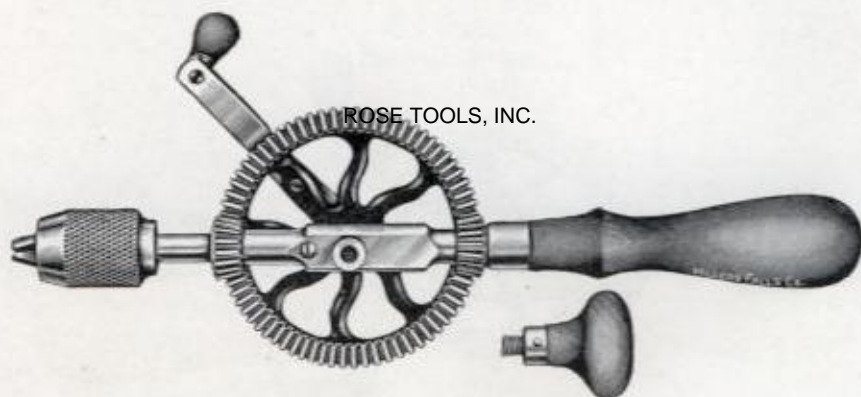

ROSE TOOLS, INC.

Differs from our other large drills mainly because it has solid steel frame.

Specifications

Chuck—3 jaw. Improved protected springs. Capacity 0-3/8 in., round shanks. Single speed. Steel pinions. Cut gears. Idler pinion to equalize bearings. Handles stained hardwood. Main handle solid, side handle detachable. Large gear enameled red. All other metal parts polished.

Length 12½ inches.

Weight each, 2 lbs.

Price each (without points), \$3.65

Code—Dasho

Packed one in a box.

Hand Drills

No. 1

Improved

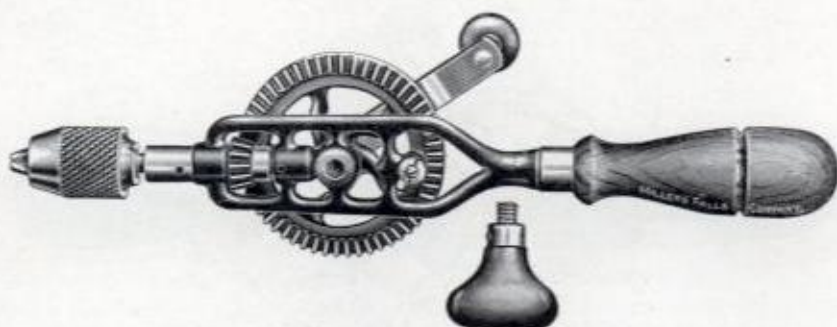

Meets a demand for a small hand drill with chuck capacity of $\frac{1}{4}$ inch.

Specifications

Chuck—three jaw. Improved protected springs.

Capacity $0-\frac{1}{4}$ in., round shank drills.

Single speed. Ball thrust bearing. Cut gears. Steel pinion and gear stud.

Adjustable equalizing bearing to prevent play of large gear. Detachable side handle.

Hollow end main handle of cocobolo, containing eight wood boring points.

Malleable iron frame, enameled black. Large gear enameled red. Other metal parts nickered.

Length $12\frac{1}{2}$ inches.

Weight each, $1\frac{3}{4}$ lbs.

Price each (with points), \$3.40

Code—*Dafne*

Packed one in a box.

No. 315 (Ratchet)

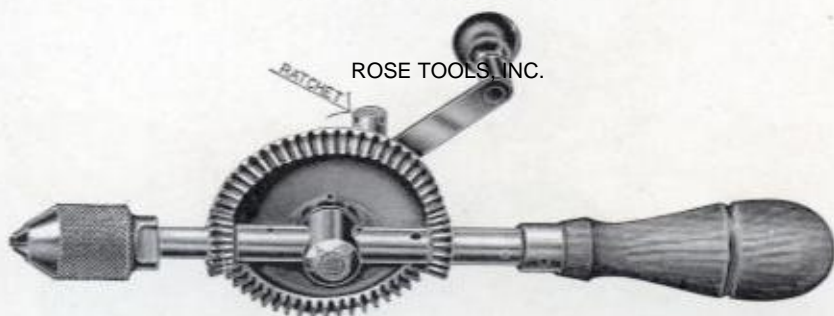

ROSE TOOLS, INC.

Drilling in cramped quarters even where there is but an inch or so space to move the crank handle, is easy with this tool. Particularly serviceable for light automobile repair work.

Specifications

Chuck—three jaw. Improved protected springs. Capacity $0-\frac{1}{4}$ in. round shanks.

Ratchet—operated by boss on crank handle. Cut gears. Pinion of steel.

Single speed. Hardened thrust collar. Steel idler gear to equalize bearings.

Hollow end main handle—stained hardwood. Frame—steel, polished and nickered.

Large gear enameled red. Other exposed metal parts nickered.

Length $11\frac{1}{2}$ inches.

Weight each, 1 lb. 3 oz.

Price each (without points), \$3.85

Code—*Daglo*

Packed one in a box.



Hand Drills

No. 5

Improved

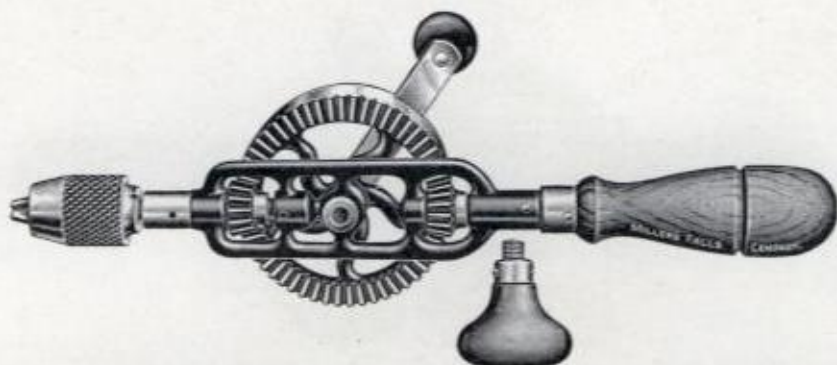

The two chief features of this drill are the wide rim on the large gear which can be firmly held between the thumb and finger tips in doing delicate work, and the double pinions which make it exceptionally smooth in action. It is our most popular small hand drill.

Specifications

Chuck—three jaw, improved protected springs. Capacity 0- $\frac{1}{4}$ in. round shank drills.

Single speed. Ball thrust bearing. Cut gears. Steel pinions, and gear stud.

Double pinion, including idler pinion to equalize the bearings. Side handle detachable.

Hollow end main handle of cocobolo, containing eight wood boring points.

Large gear nicked and enameled red; malleable iron frame, enameled black. Other metal parts nicked.

Length 12 $\frac{1}{2}$ inches.

Weight each, 1 $\frac{3}{4}$ lbs.

Price each (with points), \$3.70

Code—Dangl

Packed one in a box.

ROSE TOOLS, INC.

Improved

No. 05

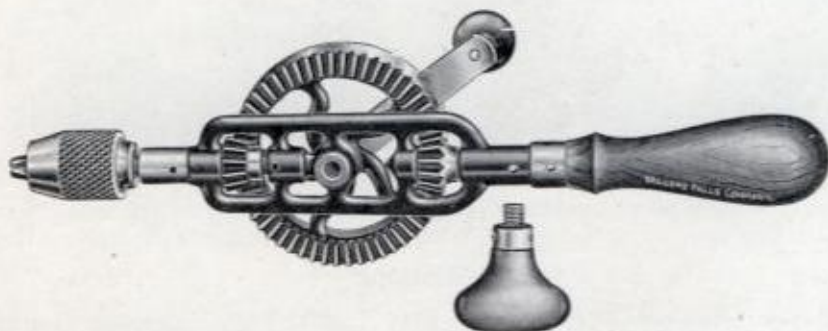

Identical with No. 5 except that the main handle is solid, of stained hardwood, and no drill points are furnished.

Length 12 $\frac{1}{2}$ inches.

Weight each, 1 $\frac{1}{2}$ lbs.

Price each, \$3.35

Code—Danki

Packed one in a box.

Radio Hand Drill

No. 85

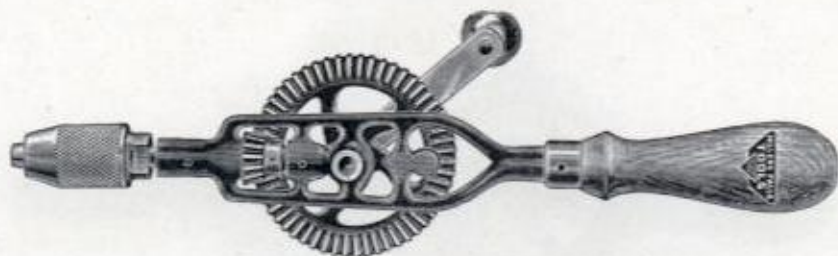
New

Every one of your customers who is interested in radio will be interested in this new drill. It is built especially for "radio fans"—is sturdy—takes all drills used in radio work; handsomely finished and most important of all perhaps, made to sell at a price within reach of every one. This is our best selling hand drill.

Packed in a special display box (with 2 color display card) illustrated below.

Specifications

Chuck—3 jaw. Improved protected springs. Capacity 0- $\frac{1}{4}$ in. round shank drills. Single speed. Ball thrust bearing. Cut gears. Steel pinion and gear stud. Solid main handle of stained hardwood. Malleable iron frame enameled black. Large gear enameled red. Other parts nickeled.

Length 12 $\frac{1}{2}$ in. Weight each, 1 $\frac{3}{4}$ lbs. Price each (without drills), \$2.30.

Code—Dalot

Packed one in special display box.

ROSE TOOLS, INC.

How to Display No. 85 Radio Hand Drill

In one end of the box is a collapsible holder. Set this up right and place handle of the drill full in groove allowing the chuck to rest against end of box. Place display card in back of holder.

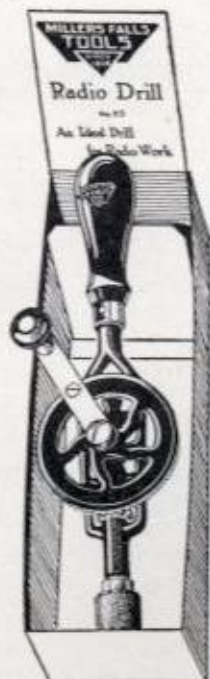

Hand Drills

No. 303

Improved

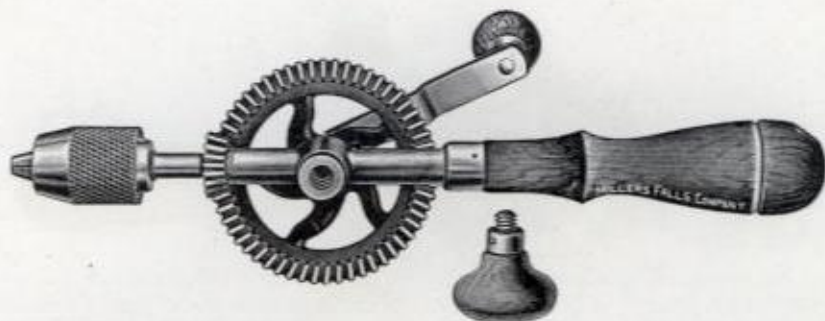

A light, sturdy drill with solid steel frame. An excellent tool moderately priced.

Specifications

Chuck—three jaw, improved protected springs, capacity 0- $\frac{1}{4}$ in. round shanks. Single speed.
Cut gears. Steel pinion. Hollow end main handle.
Side handle detachable. Both of stained hardwood.
All metal parts nicked. Large gear enameled red.

Length 11 $\frac{1}{4}$ inches.

Weight each, 1 $\frac{1}{2}$ lbs.

Price each (without points), \$2.85

Code—Dance

Packed one in a box.

ROSE TOOLS, INC.
No. 313

Improved

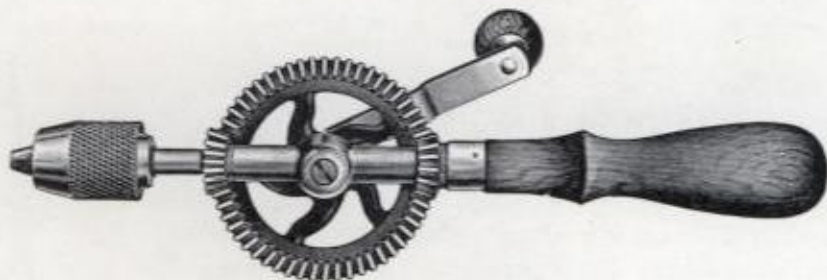

Built the same as No. 303 except that it has double pinions, solid end main handle, and is without the side handle.

Length 11 $\frac{1}{4}$ inches.

Weight each, 1 $\frac{1}{2}$ lbs.

Price each (without points), \$2.85

Code—Damak

Packed one in a box.

Hand Drills

No. 3

Improved

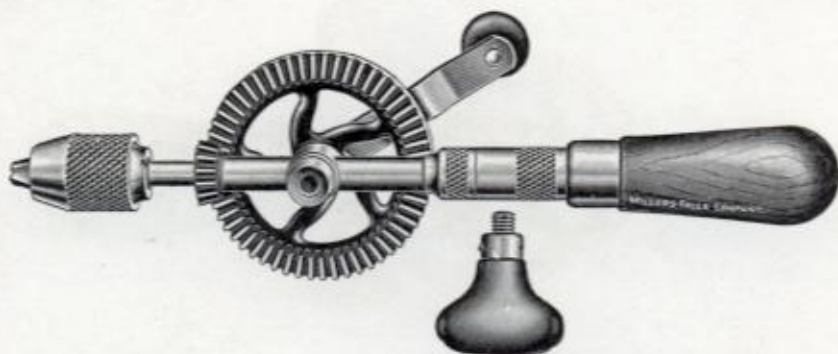

This drill differs from No. 303 only in the construction of the main handle. This is detachable and permits packing the complete drill in a very small space. Drills up to and including 3/16 in. may be carried in the handle.

Length 11 inches.

Weight each, 1½ lbs.

Price each (without points), \$3.45

Code—Danli

Packed one in a box.

No. 343

Improved

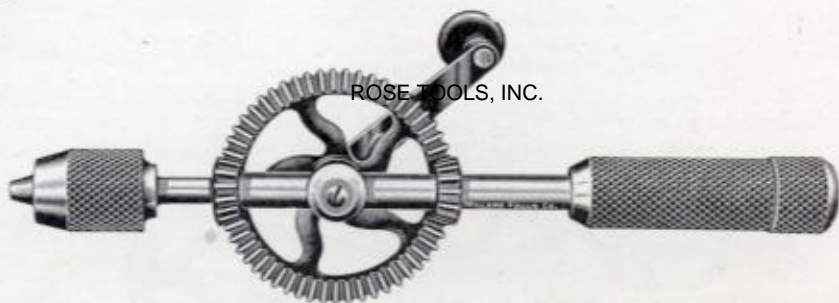

A comparatively new style of drill. Neat, compact in construction and combines beauty of appearance with serviceability. It is all metal and practically unbreakable.

Specifications

Chuck—3 jaw. Improved protected springs. Capacity 0-¼ in. round shank drills.

Single speed. Cut gears. Pinions of steel. Solid steel frame—nickel.

Main handle—hollow steel, enameled bright black.

Large gear nicked and enameled red. All other metal parts nicked.

Length 11 inches.

Weight each, 1¼ lbs.

Price each (without points), \$3.40

Code—Damit

Packed one in a box.

Hand Drills

No. 104

Improved

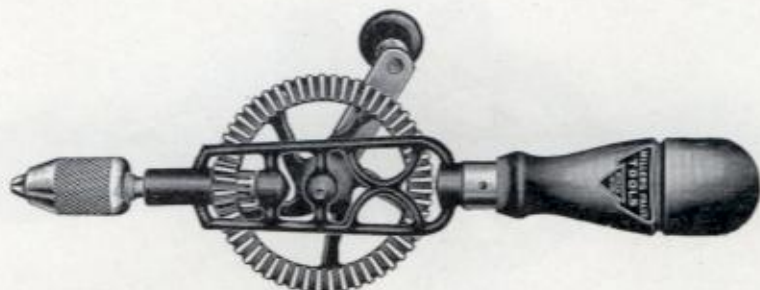

A splendid value in a low priced hand drill with hollow handle.

Specifications

Chuck—improved design, three jaw, protected springs. 0-3/16 capacity.

Single speed. Cut gears. Steel pinion and gear stud. Equalizing bearing to offset thrust of large gear.

Malleable iron frame enameled black. Large gear enameled red. All other metal parts nicked.

Length 11½ inches.

Weight each, 1¼ lbs.

Price each (including points), \$2.30

Code—Darnc

Packed one in a box.

ROSE TOOLS, INC.

No. 4D

A small hand drill designed primarily for jewelers' use, and for light drilling in wood or soft metal.



Specifications

Chuck—two jaw, capacity 1/64-1/8 inch round shank drills.

Cast iron frame and large gear.

Frame and large gear enameled black.

Steel spindle and small gear.

Chuck nicked.

Length 8 inches.

Weight each, ¾ lbs.

Price each (without points), \$1.30

Code—Daubu

Packed one in a box.



Hand Drills

No. 4



Identical with No. 4D except for the chuck, which is specially constructed for six diamond drill points which are supplied with the drill. These points will drill either wood or soft metal.

Length 8 inches.

Weight each, $\frac{3}{4}$ lbs.

Price each (including drills), \$.95

Drills per set, \$0.25.

Code—*Datic*

Packed one in a box.

Hand Drill Points

For Wood

These points are for use in wood and soft metal only.



Price per set of 8, \$.30

Code—*Darto*

Price per dozen, \$.45

Code—*Dasta*

Packed per set, or per dozen, in a round wooden box.

ROSE TOOLS, INC.

For Metal

The only difference between these and regular twist drills is the length $2\frac{3}{4}$ in. overall. They are the same as are supplied with No. 2D Hand drills. Will cut any material that can be drilled.

Sizes, $\frac{1}{8}$ in., $\frac{5}{32}$ in., $\frac{3}{16}$ in., $\frac{7}{32}$ in., $\frac{1}{4}$ in., $\frac{9}{32}$ in.

Code—*Dazel*

Price per set of six, \$1.30

Packed one set in a round wooden box.



Breast Drill (Ratchet) No. 97

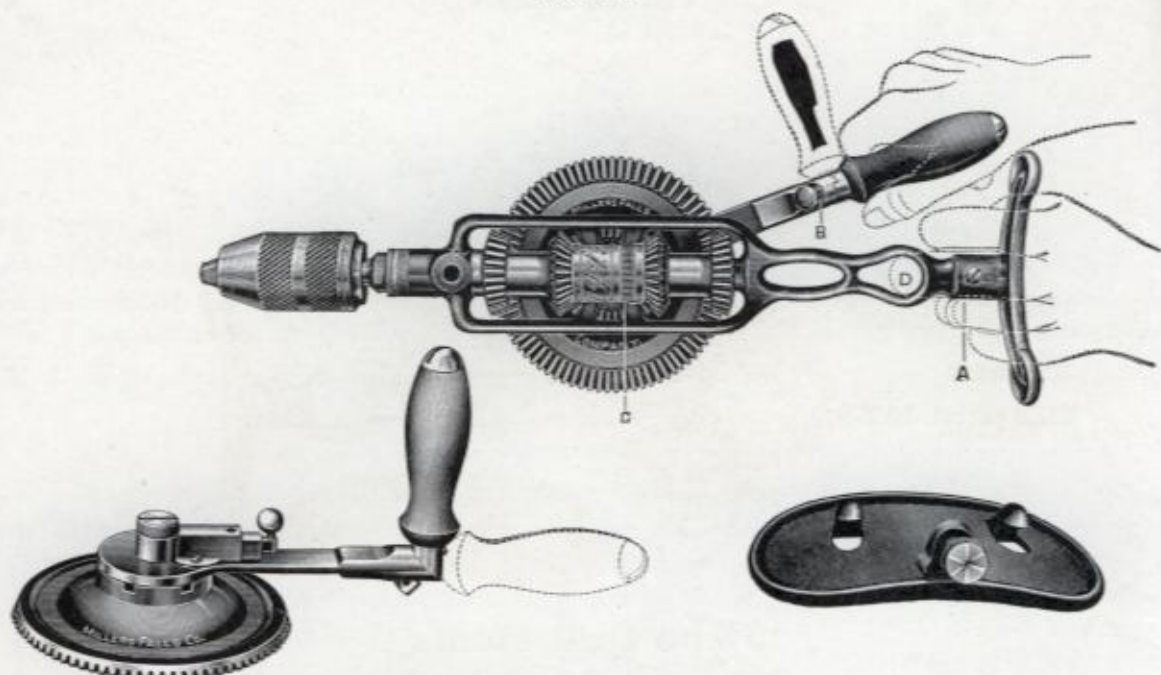

Unquestionably the most complete breast drill on the market, not only in its capabilities, but in its construction as well.

It will reach places inaccessible with the ordinary breast drill. Saves the time usually spent in tearing down to make repairs. Turning the knurled sleeve (Fig. C.) operates the ratchet; pressing the knob on crank handle changes the speed instantly without removing drill from the work. No simpler operations can be conceived.

With all its ingenuity, is a fool proof, strong tool that will give a lifetime of the hardest service.

ROSE TOOLS, INC.

Five actions:

Special Features

1. Neutral position, which gives the drill the ordinary direct drive without ratchet action in both fast and slow speeds.
 2. Ordinary right-hand ratchet action in which the chuck stops turning on backward stroke of the crank.
 3. Ordinary left-hand ratchet action.
 4. Continuous right-hand ratchet action in which the chuck turns continuously to the right on both forward and backward strokes of the crank.
 5. Continuous left-hand ratchet action.
- Fast and slow speeds separated by bushings, friction greatly reduced.
Crank handle adjustable for use as ordinary crank or as straight lever for ratchet action.
Frame has hand-hold for steadying tool.
Take up nut to overcome any wear in ball bearings.
Double gear drive. Improved shifter sleeve.

Specifications

- | | |
|--|--------------------------------------|
| Chuck—3 jaw. Improved protected springs. | Capacity 0-1/2 in. round shanks. |
| Speeds—two. Gear ratios even and 2 3/4 to 1. | Handles—hardwood stained. |
| Cut gears. Steel pinions. | Frame—malleable iron enameled black. |
| Ball thrust bearing. | Large gear enameled red. |
| Large auxiliary breastplate. | Other metal parts nicked. |
| Length 17 1/2 inches. | Weight each, 8 1/4 lbs. |
| | Price each, \$11.65 |

Code—Dater

Packed one in a box and twelve in a case.



Breast Drill (Ratchet)

No. 200

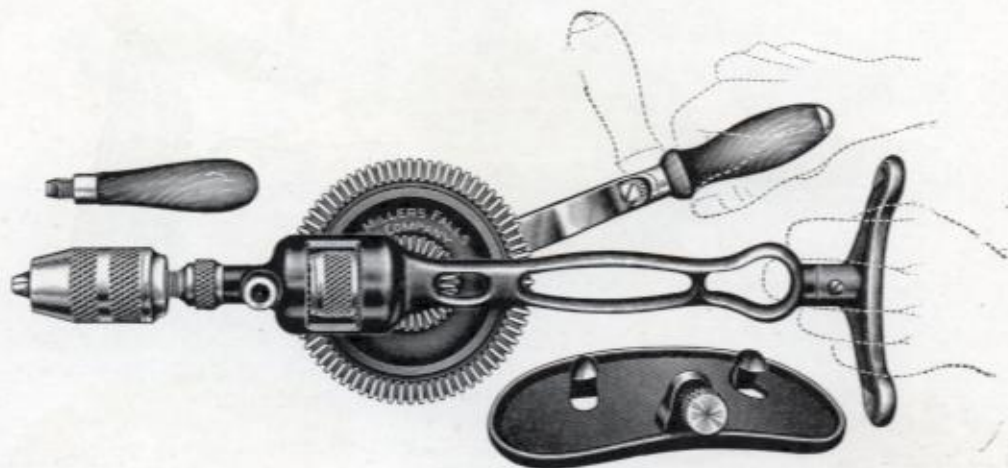

For all ordinary drilling this tool with plain right and left-hand ratchet answers every purpose. It is simple in design, yet thoroughly practical.

Special Features

Slightly rotating the knurled ring changes the speed instantly at any point, and without removing drill from the work. A turn of the boss on crank handle operates the ratchet.

Crank handle usable in regular way or can be turned to straight lever for greater power.

Auxiliary breastplate for comfort and power in doing heavy work.

Frame has hand hold for steadying tool.

ROSE TOOLS, INC.

Specifications

Chuck—three jaw. Improved protected springs. Capacity 0- $\frac{1}{2}$ inch round shanks.

Speeds—two. Gear ratios even and 3 to 1.

Equalizing bearing to offset play of large gear.

Cut gears. Steel pinions—protected.

Ball thrust bearing.

Handles—stained hardwood.

Frame—malleable iron enameled black.

Large gear enameled red.

Other metal parts nickeled.

Length 18 inches.

Weight each, 7 lbs.

Price each, \$8.35

Code—Dawdl

Packed one in a box and twelve in a case.



Breast Drills

No. 100

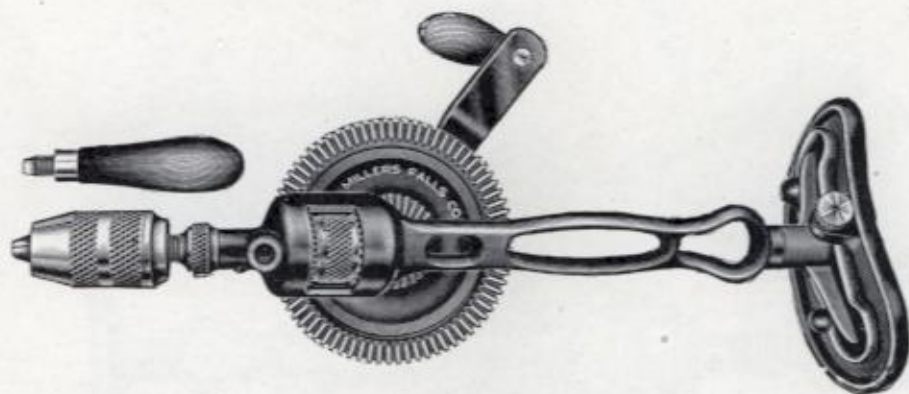

This drill is the same No. 200 except it is without ratchet, and the crank is stationary, usable only in the ordinary way. Crank is japanned instead of nickeled.

Length 18 inches.

Weight each, 7 lbs.

Price each, \$6.20

Code—Dazel

Packed one in a box and twelve in a case.

No. 2100

ROSE TOOLS, INC.

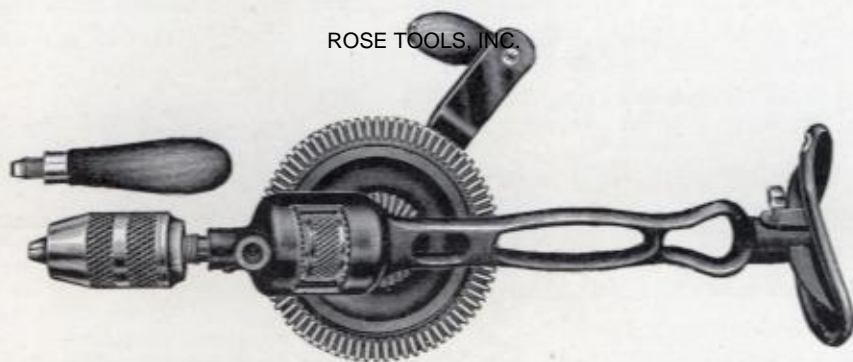

Same general construction as No. 100. The only essential difference is that it is without the ball thrust bearing and auxiliary breastplate.

Specifications

Identical with No. 100 except that the metal parts are polished instead of nickeled.

Length 17½ inches.

Weight each, 5¾ lbs.

Price each, \$5.25

Code—Deary

Packed one in a box and twelve in a case.

Breast Drills No. 118

Improved



This drill has been a standard for many years. It is built along simple lines yet has every feature essential to good drilling. It is a "full of service" drill at a moderate price.

Specifications

Chuck—three jaw Improved protected springs. Capacity 0- $\frac{1}{2}$ inch round shanks.
 Speed—two. Gear ratios even and 3 to 1. Changed by pressing spring and shifting large gear.
 Annular ball bearing spindle, as well as ball thrust bearing, with take up nut to provide for wear.
 Frame has hand hold for steadying tool.
 Handles—stained hardwood. Crank handle extensible. 4 to 6 inch radius.
 Cut gears. Pinion of steel. Idler roll to equalize bearing. Adjustable breastplate.
 Frame malleable iron enameled black. Level attached.
 Large gear enameled red. Other metal parts nickeled.

Length 17 $\frac{1}{2}$ inches.

Weight each, 6 $\frac{1}{2}$ lbs.

Price each, \$6.50

Code—Decad

Packed one in a box and twelve in a case.

No. 29

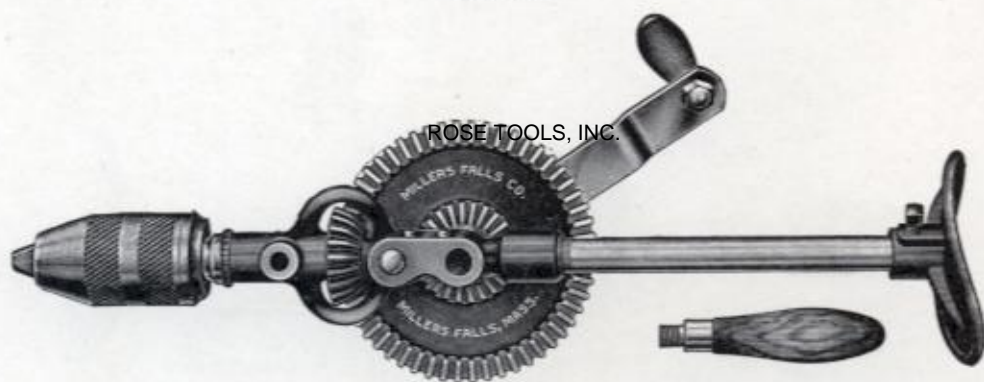

ROSE TOOLS, INC.

A medium priced drill. Built with all its value in its construction rather than high finish. Is of the simplest possible design yet with every essential feature.

Specifications

Chuck—three jaw. Improved protected springs. Capacity 0- $\frac{1}{2}$ inch round shanks.
 Speed—two. Gear ratio even and 3 to 1. Changed by pressing spring and shifting large gear.
 Ball thrust bearing. Cut gears. Pinion of steel. Handles—stained hardwood.
 Adjustable breastplate. Crank handle extensible. Radius 4 to 7 inches.
 Frame—rolled steel and cast iron. Large gear enameled red.
 Iron frame and breastplate enameled black. Other metal parts polished.

Length 18 inches.

Weight each, 6 $\frac{1}{4}$ lbs.

Price each, \$4.75

Code—Decem

Packed one in a box and twelve in a case.

Breast Drills

No. 293

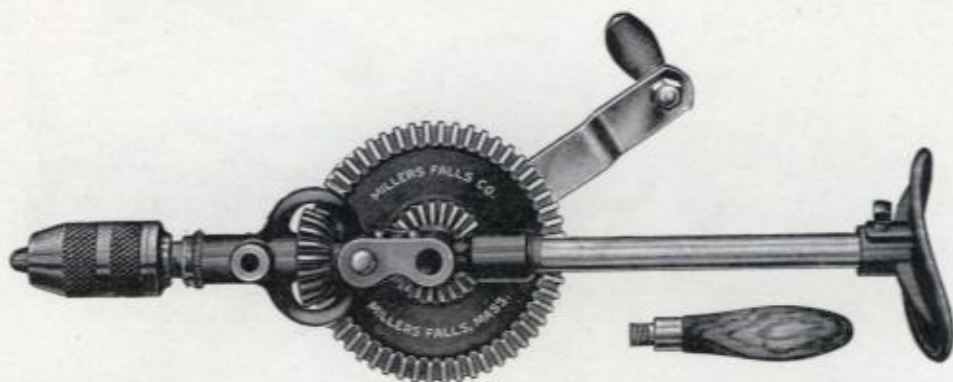

This drill is identical with No. 29 except that the chuck capacity is $0\text{-}\frac{3}{8}$ inch instead of $0\text{-}\frac{1}{2}$ inch. This range is ample for many types of drilling, particularly light automobile repair work.

Specifications

Same as No. 29 except chuck capacity, $0\text{-}\frac{3}{8}$ inch.

Length 17 inches.

Weight each, $6\frac{1}{4}$ lbs.

Price each, \$4.25

Code—Decoz

Packed one in a box and twelve in a case.

No. 212

ROSE TOOLS, INC.

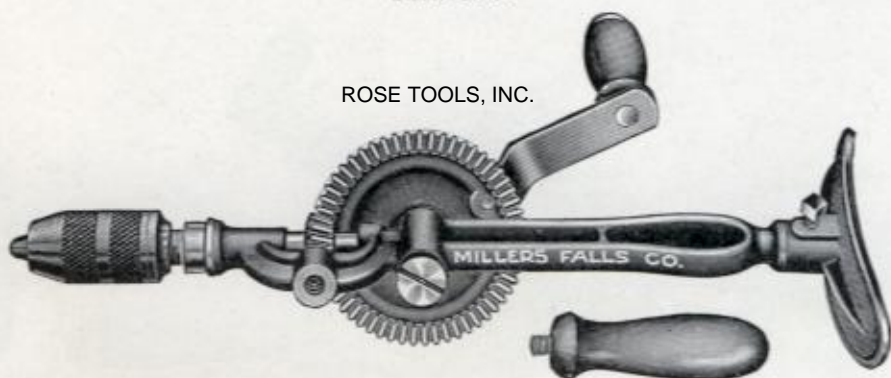

This tool is made especially for those who have only an occasional use for a breast drill. It is inexpensive, yet well built and will give satisfaction and good service on light work.

Specifications

Chuck—three jaw. Improved protected springs. Capacity $0\text{-}\frac{3}{8}$ inch round shank drills.
 One speed. Gear ratio $3\frac{1}{2}$ to 1. Frame—malleable iron enameled black.
 Hardened steel washer as thrust bearing. Large gear—enameled red.
 Cut gears. Small gear of steel. Chuck—polished.
 Adjustable breastplate.

Length $14\frac{1}{2}$ inches.

Weight each, $3\frac{3}{4}$ lbs.

Price each, \$3.75

Code—Decla

Packed one in a box.

Breast Drills (Ratchet)

No. 87

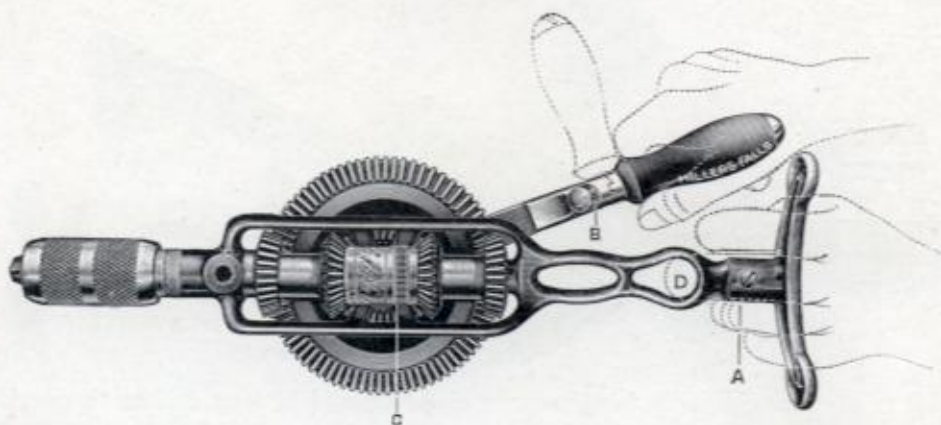

The same drill as No. 97 (page 58) in every particular, except has Master two jaw chuck. The advantage of this type of chuck lies in the patent milled forged steel jaws that hold bit, round, from $\frac{1}{8}$ to $\frac{1}{2}$ inch, and No. 1 Morse Taper shanks.

Specifications

Identical with No. 97 except chuck.

Length 17 inches.

Weight each, 8 lbs.

Price each, \$10.90

Code—Daunt

Packed one in a box and twelve in a case.

No. 99
ROSE TOOLS, INC.

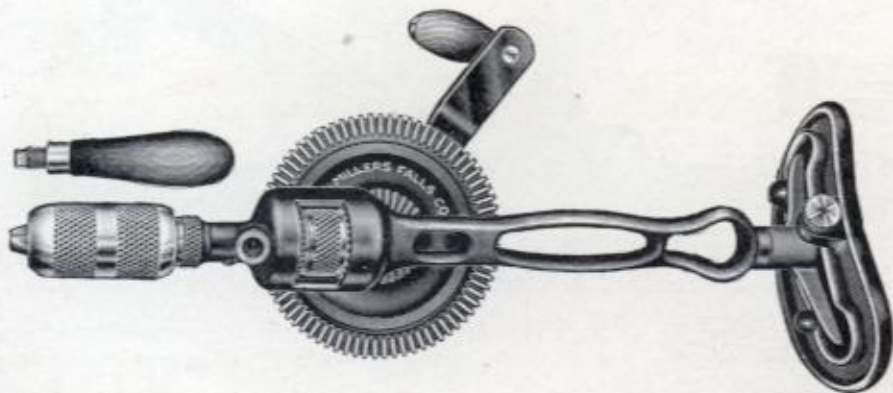

This drill is the same as No. 100 (page 60) except that it has Master chuck. It is one of our newer drills, characterized by its simplicity of design.

Length 18 inches.

Weight each, 7 lbs.

Price each, \$6.05

Code—Decon

Packed one in a box and twelve in a case.

Breast Drills

Improved

No. 12

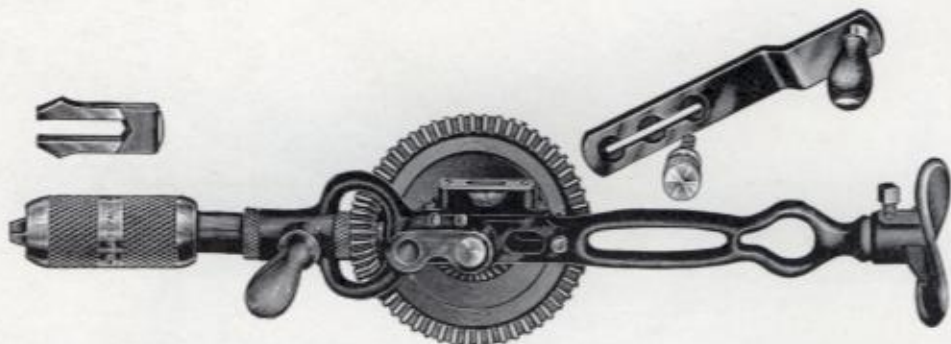

It is safe to say that this is the best known and most popular breast drill on the market. It is one of our original drills. Every feature essential to a serviceable breast drill is built into it, and it is an exceptional value for the price.

Specifications

Identical with No. 118 (page 61) except has Master chuck as on Nos. 87 and 99.

Length 17½ inches.

Weight each, 6½ lbs.

Price each, \$5.75

Code—Debut

Packed one in a box and twelve in a case.

Improved

No. 15

ROSE TOOLS, INC.



This drill is built especially for railroad car repair work. The D shaped handle affords the secure hand hold necessary in this type of work. Identical with No. 12 except has D shaped handle in place of breastplate.

Specifications

The same as No. 118 (page 61) except for chuck.

Length 19 inches.

Weight each, 6½ lbs.

Price each, \$5.75

Code—Decap

Packed one in a box and twelve in a case.

Breast Drills

No. 10

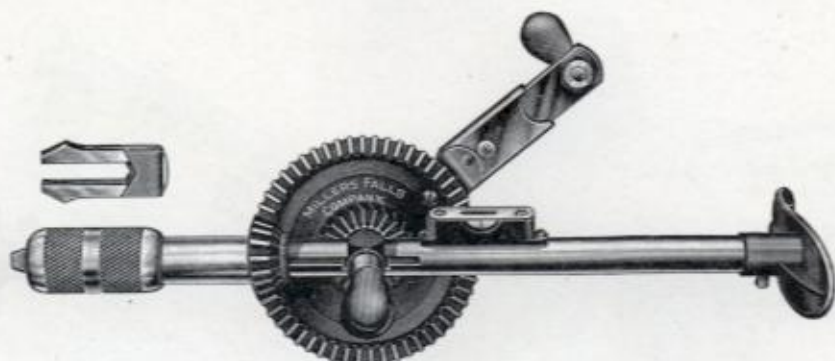

This drill is preferred by many mechanics because of its solid steel frame. It is a well balanced tool, built along simple lines and is handsome in appearance.

Specifications

Chuck—Master two jaw, as on No. 12.
Speed—two. Gear ratios even and 3 to 1.
Cut gears. Steel pinion.
Ball thrust bearing.

Crank handle extensible $5\frac{1}{2}$ to 7 inches.
Adjustable breastplate. Level attachment.
Handles—stained hardwood.
Frame—solid steel polished and nicked.

Length 17 inches.

Weight each, $6\frac{1}{2}$ lbs.

Price each, \$6.90

Code—Debos

Packed one in a box and twelve in a case.

No. 13

ROSE TOOLS, INC.

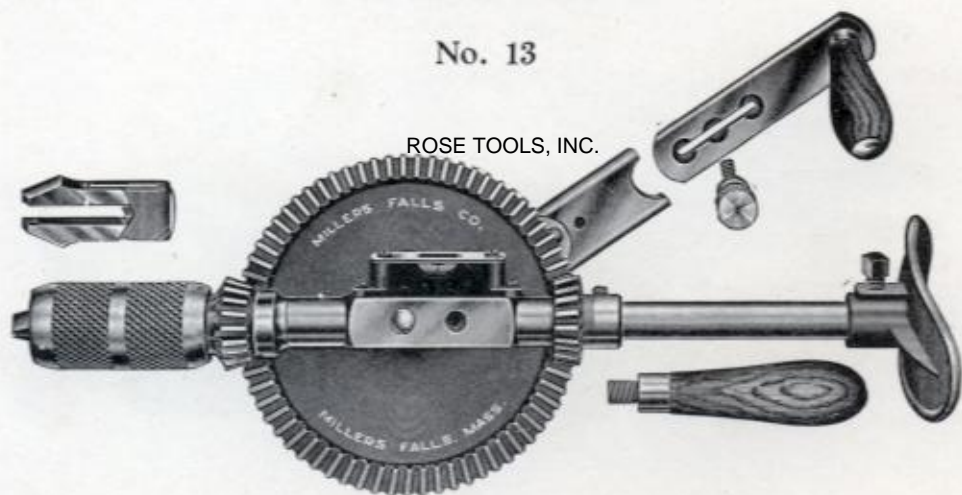

The feature of this drill is the extra large main gear, with diameter of 6 inches, which gives a speed of $4\frac{1}{2}$ to 1. It is especially desirable where rapid drilling is essential.

Specifications

Single speed. Idler gear to equalize bearings. In other respects identical with No. 10.

Length 15 inches.

Weight each, $5\frac{3}{4}$ lbs.

Price each, \$7.20

Code—Debar

Packed one in a box and twelve in a case.



Breast Drills

No. 12A

Improved

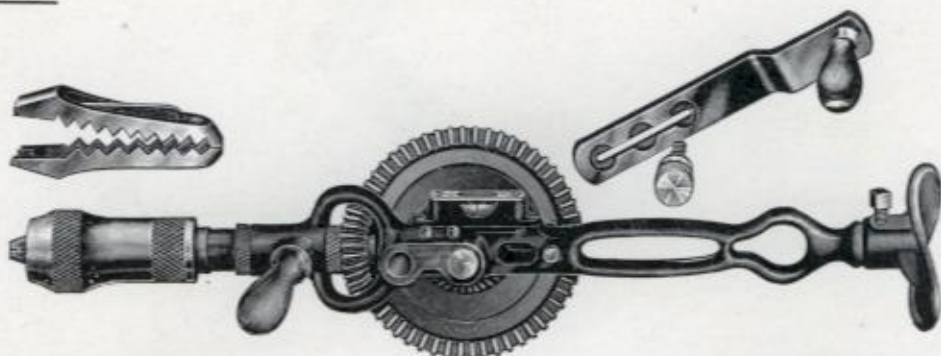

There are many mechanics whose work principally requires the use of bit shank drills. To meet this demand we build several breast drills with our Barber two jaw chuck. No. 12A is identical with No. 12 (page 64) except for this detail.

Specifications

Length 17½ inches.

Weight each, 6¼ lbs.

Price each, \$5.65

Code—Decag

Packed one in a box and twelve in a case.

No. 19

ROSE TOOLS, INC.

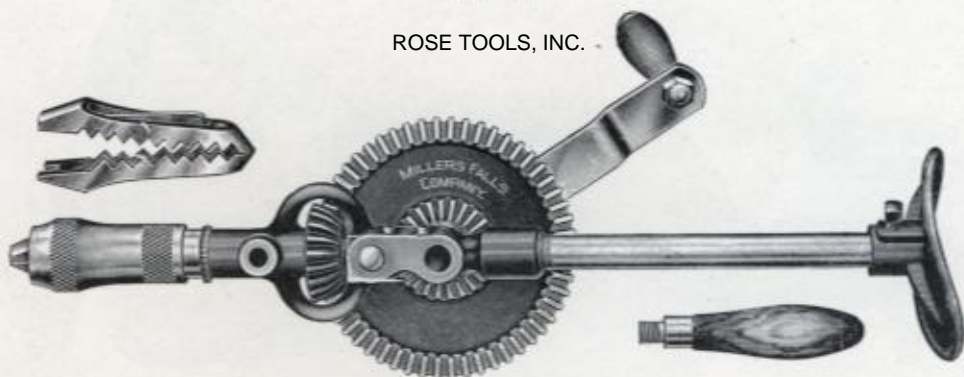

Every feature essential to efficient drilling is built into this tool. Because of its simple design it is less expensive than some of our other drills.

Chuck—Barber, two jaw for bit shanks only.

In other respects identical with No. 29, page 61.

Specifications

Length 18 inches.

Weight each, 6½ lbs.

Price each, \$4.40

Code—Decus

Packed one in a box and twelve in a case.



**Breast Drill
No. 112**

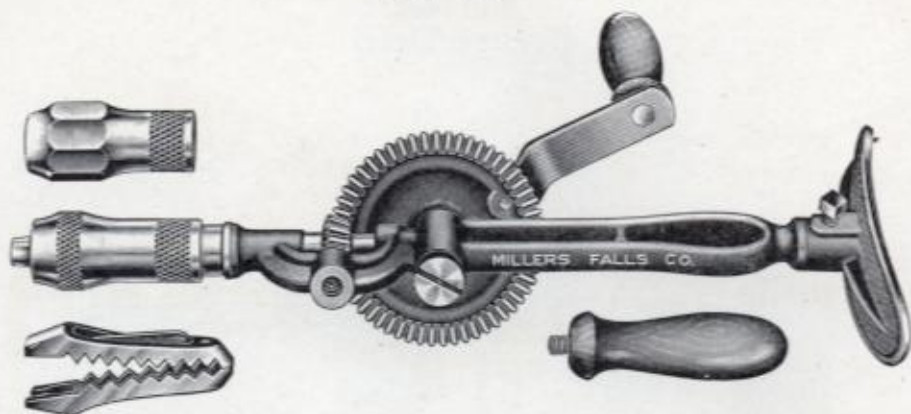

An ideal drill for use about the home or for light work. It is built primarily for those who have but occasional use for a breast drill.

Specifications

Identical with No. 212 (page 62), except has Barber chuck for bit shanks only.

Length 15 inches.

Weight each, 4 lbs.

Price each, \$3.15

Code—Decks

Furnished with octagon shells, each, extra, \$0.05.

Equipped with level, each, extra, \$0.20.

Extra jaws, plain with fine print for small sizes of round shanks, per pair, \$0.25.

**Breast Drill Chuck
No. 153**



ROSE TOOLS, INC.

The purpose of this chuck is to convert a three jaw breast or bench drill into a two jaw type. It will be found especially practicable where the drilling requirements range from the use of small round shanks to the use of bit and No. 1 Morse Taper shanks. Shank is squared for convenience in tightening.

No. 153 is our Master type, holding round shanks from $\frac{1}{8}$ to $\frac{1}{2}$ inches, bit and No. 1 Morse Taper shanks. It fits the spindle of any Millers Falls' breast or bench drill equipped with three jaw chucks, capacity 0 to $\frac{1}{2}$ inch.

Weight each, 13 oz.

Code—Dilat

Price each, \$1.65

Packed one in a box.

D Handle

This type of handle affords a powerful handhold, and is particularly useful in railroad car repair work. Fits all our breast drills and is interchangeable with breastplate. Furnished in place of breastplate if desired, without extra charge.



Price each, \$0.40.

Code—Decip



Breast Drill

No. 25

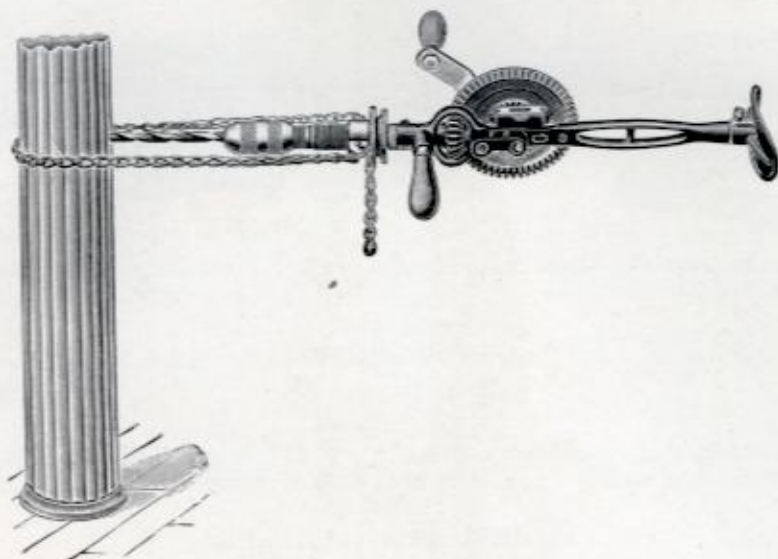

ROSE TOOLS, INC.

This tool is a combination breast and chain drill. Its purpose is to facilitate the drilling of rails, girders, pipe or any material where it is possible to put a chain around the work.

It is superior to the separate drills in construction, because it is much more compact; and in operation, because the work is brought nearer to the operator.

Specifications

The breast drill is our No. 12 (page 64), with Master chuck, holding bit, round from $\frac{1}{8}$ to $\frac{1}{2}$ inch and No. 1 Morse Taper shanks.

The chain drill is our No. 718 pattern having both automatic friction feed and hand feed. Requires no pressure whatever on the breastplate. Ball thrust bearings at two points in the main drill, and also in the chain drill extension, make it exceptionally free running. Three feet of stout chain is furnished for the chain drill.

Length 20 inches.

Weight each, 8 lbs.

Price each, \$8.25

Code—Decra



Bench Drill

No. 207



ROSE TOOLS, INC.

This drill is built along simple lines, and is an ideal tool for light work. It is neat, clean cut and thoroughly well made.

Specifications

Feed—hand wheel at top of frame. One speed, ratio 3 to 1.

Chuck—three jaw. Improved protected springs. Capacity 0- $\frac{1}{4}$ inch round shanks.

Cut gears. Steel pinion.

Frame—cast iron enameled black.

Feed wheel and large gear enameled red.

Chuck, nicked. Maximum distance from chuck to table 4 $\frac{1}{2}$ inches.

Height overall, 18 inches.

Weight 8 $\frac{1}{2}$ lbs. net, 13 lbs. gross.

Price \$8.00

Code—Delux

Packed one in a wooden box.

Note—Will take Post or Wall Clamp, illustrated on page 73.



Bench Drill

No. 216

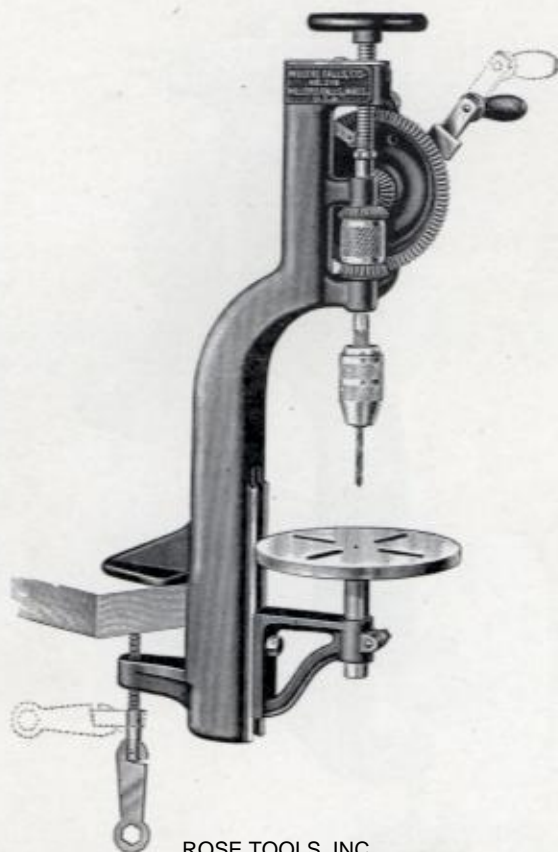

ROSE TOOLS, INC.

Unquestionably the most complete hand power Bench Drill made.

The distinguishing feature is the feed construction. Two rates of automatic feed positive in action are insurance against drills breaking when about to go through the work, or when used on thin material. Also it gives the operator free use of one hand to hold the work. Drill can be fed by hand if desired, by means of feed wheel conveniently located at top.

Three frame bearings hold the drill spindle and feed screw making it unusually strong and rigid.

Specifications

Two speeds, ratios even and $3\frac{1}{2}$ to 1. Instantly changed by turning knurled sleeve.

Cut gears. Pinions of steel. Ball thrust bearings.

Crank handle extensible, 3 to $6\frac{1}{2}$ inch radius.

Chuck—three jaw, improved protected springs. Capacity 0 to $\frac{1}{2}$ inch round shanks.

Table $7\frac{1}{2}$ inch in diameter slotted to receive vise clamps or posts to hold work in place.

Steel feed screw, spindle and chuck. Cast iron frame, large gear and table.

Chuck and knurled sleeve nicked. Frame enameled black. Large gear enameled red.

Other machined parts polished. Traverse of automatic feed $2\frac{1}{8}$ inches.

Distance from table to chuck 8 inches. Vertical adjustment of table bracket $5\frac{3}{4}$ inches.

Vertical adjustment of table in its bracket $2\frac{1}{2}$ inches.

Height above bench 22 inches. Height overall 28 inches.

Weight boxed 50 lbs., net 30 lbs.

Code—Defro

Price each, \$23.75

Packed one in a wooden box.

(This drill can be equipped for power use by means of extra length large gear shaft to accommodate a 4 in. x 2 in. pulley. Special price upon request.)

Bench Drill

No. 218

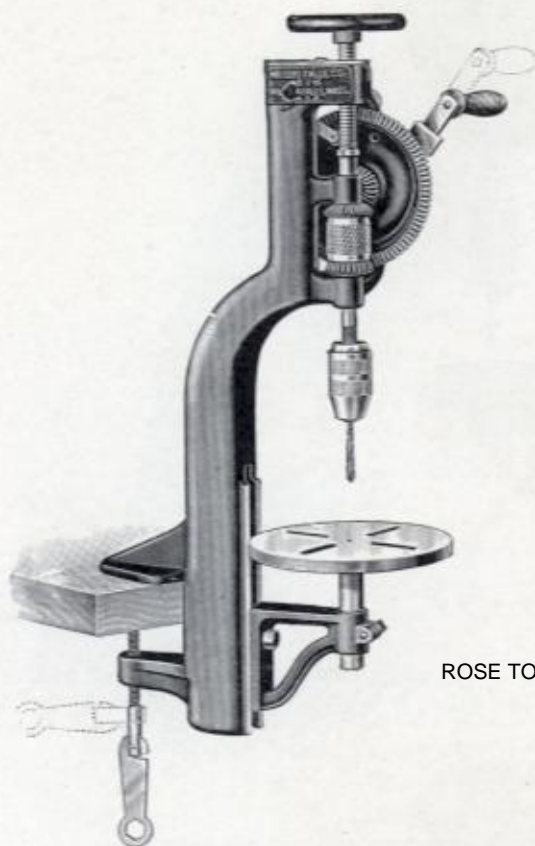

ROSE TOOLS, INC.

This is the same drill as No. 216 with the addition of the wall clamp illustrated at right. This clamp securely grips the main frame and is fastened with screws to a wall or post.

Weight boxed 56 lbs.

Net 36 lbs.

Price each, \$26.50

Code—Defty

Packed one in a wooden box.



Bench Drill

No. 210

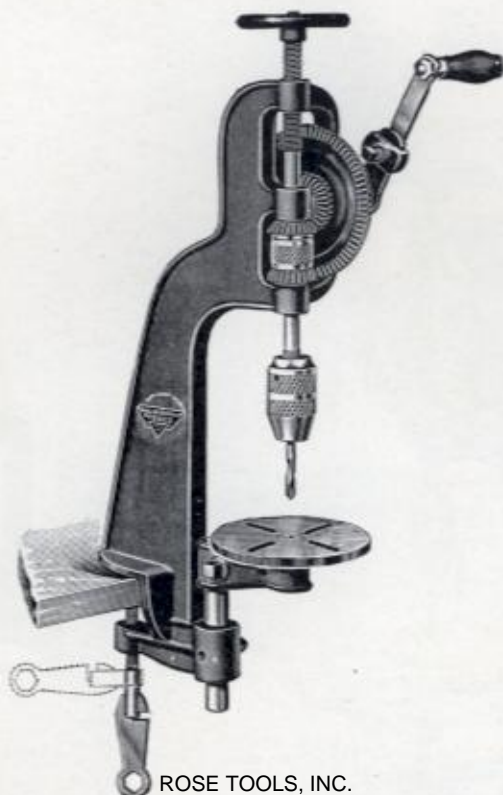

ROSE TOOLS, INC.

A bench drill with hand feed is adequate, unless there is a large amount of drilling to be done. No. 210 is a rigid, strongly built and accurate drill. It is thoroughly efficient and an exceptional value for the price.

Specifications

Feed. Hand wheel conveniently located at top.

Two speeds, ratios $1\frac{1}{2}$ to 1 and 4 to 1, instantly changed by turning knurled sleeve.

Cut gears. Pinions of steel. Crank handle extensible, 3 to 6 inch radius.

Chuck—three jaw, improved protected springs. Capacity 0 to $\frac{1}{2}$ inch round shanks.

Steel feed screw, spindle and chuck.

Cast iron frame, large gear and table. Chuck and knurled sleeve nickered.

Large gear enameled red. Frame enameled black.

Table and other machined parts polished.

Maximum distance from chuck to table 9 inches.

Height overall 24 inches.

Weight boxed $27\frac{1}{2}$ lbs., net 22 lbs.

Price each, \$15.00

Code—Deism

Packed one in a wooden box.

(This drill can be equipped for power use by means of extra length large gear shaft to accommodate a 4 in. x 2 in. pulley. Special price upon request.)



Bench Drills

Nos. 211-213-214

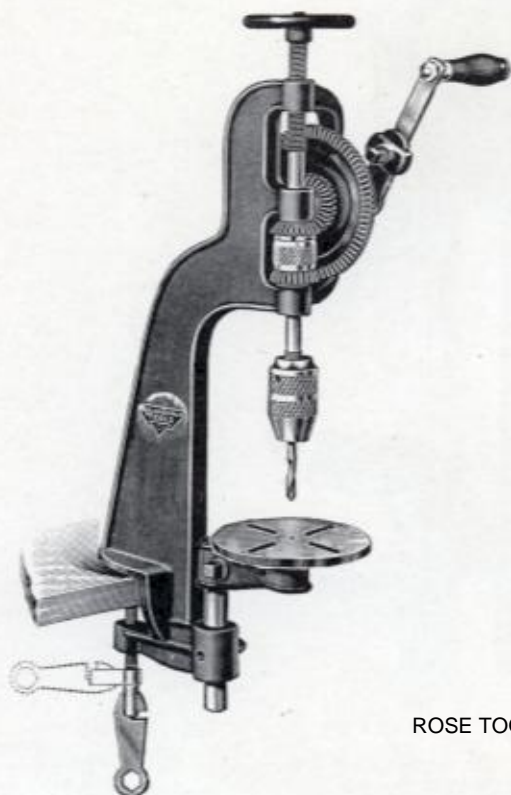

No. 211

The same as No. 210 with addition of Post or Wall Clamp illustrated.

Weight boxed, 31½ lbs. Price complete, \$16.35

Code—*Delan*

Packed one in a wooden box.



Vise No. 219

No. 213

The same as No. 210 with addition of Vise No. 219.

Weight boxed, 31½ lbs. Price complete, \$17.85

Code—*Delfi*

Packed one in a wooden box.

No. 214

The same as No. 210 with both Post or Wall Clamp and Vise No. 219.

Weight boxed, 35½ lbs.

Code—*Delta*

Price complete, \$19.00

Packed one in a wooden box.

Bench Drill

No. 20

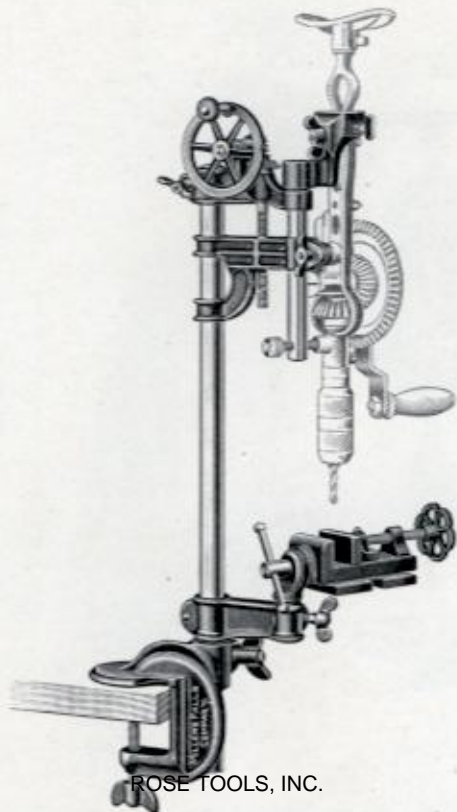

ROSE TOOLS, INC.

This tool is of particular value when the use of a bench drill is secondary to that of a breast drill. With this standard, breast drills (see note below) can be made to serve a double purpose.

The drill is easy to attach, can be swiveled into many positions and clamped at varying heights either above or below the bench.

The vise is swung on a pin off center, and can be used in any position, or at any angle with the frame, vertical to horizontal, or completely reversed and the table turned uppermost.

It is thoroughly practical and makes an efficient bench drill. Note—Can be used with the following Millers Falls breast drills Nos. 10, 12, 12A, 15, 87, 97, 99, 100, 200 and 2100.

Specifications

Feed. Governed by hand wheel, conveniently located at top.

Rapid action. Steel feed gears and post.

Post and machined parts polished.

Other metal parts japanned.

Height of standard 24 in. Weight boxed, 28 lbs., net, 19 lbs. Price without breast drill, \$10.65

Code—Demur

Packed one in a wooden box.

Bench Drill

No. 21

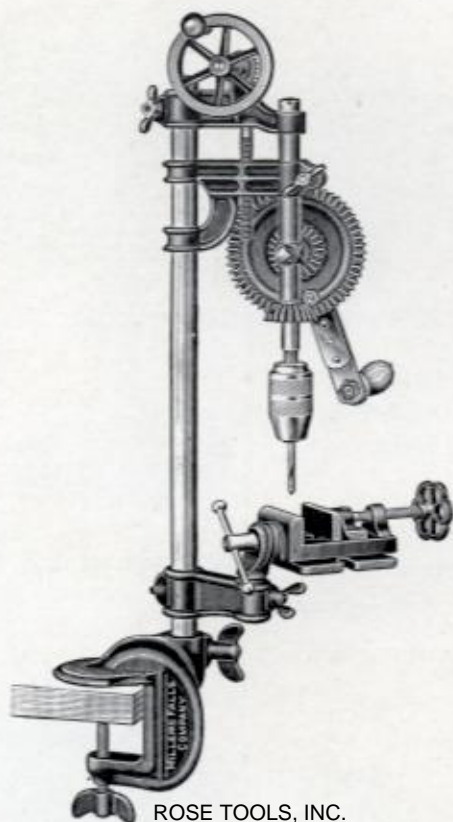

ROSE TOOLS, INC.

This drill is the same as No. 20, except it is built with drilling attachment permanently affixed. It is a complete tool in itself. This construction permits several features not possible in No. 20.

Specifications

Feed same as No. 20. Speeds—two. Ratios even and 3 to 1.

Chuck—three jaw, improved protected springs. Capacity 0- $\frac{1}{2}$ inch round shanks.

Extensible crank handle, radius from 5 to 6 $\frac{1}{2}$ inch.

Ball thrust bearing. Cut gears. Steel pinion.

Chuck, spindle and crank nicked.

Other parts finished same as No. 20.

Weight boxed, 30 lbs., net 21 lbs.

Price complete, \$15.00

Code—Demye

Packed one in a wooden box.

Bench Drills

No. 22

The purpose of this tool is to convert a hand drill into a small bench drill for wood or metal drilling. The hand drill is easily inserted and firmly held by an adjustable clamp. Drill can be fed as rapidly or as slowly as desired by means of sensitive compound lever. It is well made and makes a convenient and effective tool.

Holds the following Millers Falls' hand drills: Nos. 1, 2, 2B, 2D, 5, 05, 3 and 303.

Will hold No. 980 and No. 1980 by using special clamp costing 15c. each.

Specifications

Height of standard above bench 15½ inches.

Grey iron frame, enameled black.

Steel standard.

Steel lever—polished.

Weight 8 lbs.

Price without drill, \$4.60

Code—Denit

Packed one in a box.



ROSE TOOLS, INC.

No. 23

The same drill as No. 22 except has drilling attachment built in, making a complete tool in itself.

Specifications

Chuck—three jaw, improved protected springs. Capacity 0—¾ round shank drills.

Chuck, drill spindle and crank nickered.

All other metal parts japanned.

Weight 9 lbs.

Price, \$6.35

Code—Denit

Packed one in a box.





Bench Drill Vises

No. 217

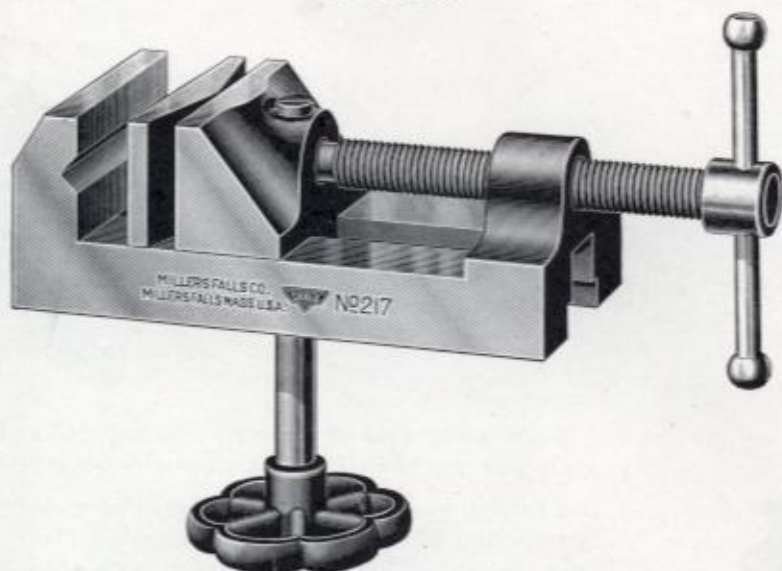

For use with drills Nos. 210, 211, 216 and 218. Clamps to table of drill. Detachable swivel jaw holds irregular shapes. Steel screw. Jaws, base, sides and bearing parts accurately machined. Vise opens $2\frac{5}{8}$ inches. Without swivel jaw opens 3 inches. Width of jaws $2\frac{3}{8}$ inches. Weight $4\frac{3}{4}$ lbs.

Code—Deign

Price each, \$3.35

No. 219

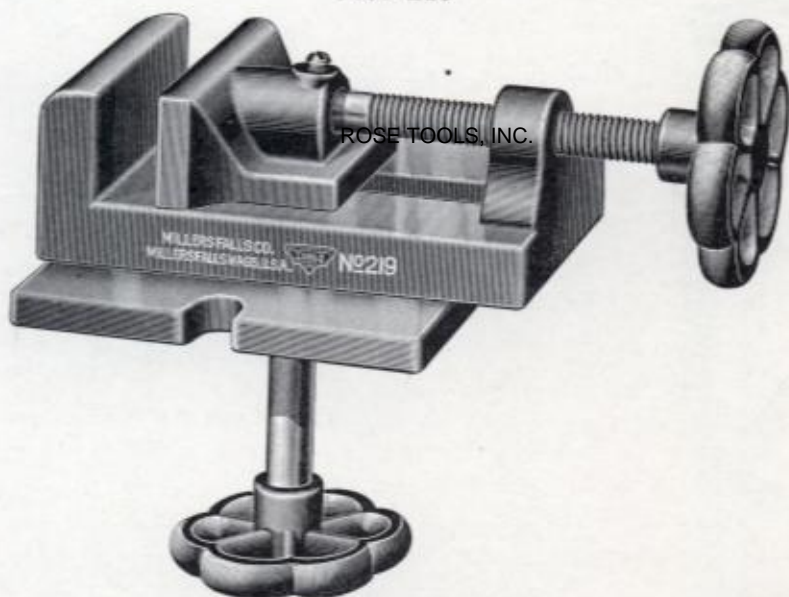

Vise No. 219

For use with Bench Drill No. 210. Similar to No. 217 Vise, but is without swivel jaw and not as highly finished.

Width of jaws $2\frac{1}{4}$ inch. Weight 4 lbs.

Jaw open $1\frac{5}{8}$ inch.

Code—Degna

Price each, \$2.70

Chain Drill

No. 717

An auxiliary tool for use with a breast drill or bit brace, when extra power is needed, or where pressure cannot be easily applied.

The drill is automatically fed into the work by an adjustable friction feed which is automatically regulated by the resistance the drill encounters. Drill breakage is, therefore, reduced to a minimum. Requires but a moment to adjust the chain. Reverse movement of brace withdraws drill. No intricate parts to get out of order. Hand feed can be used if desired. Four feet of stout chain with each drill.



Specifications

Socket hole has diameter of $\frac{1}{2}$ inch for holding shanks with this diameter. ROSE TOOLS, INC.

Square head set screw holds shanks securely.

Socket drilled for $\frac{5}{8}$ inch shanks, without charge, if requested.

Length of main spindle $8\frac{1}{2}$ inches.

Weight $3\frac{1}{2}$ lbs.

Price, \$3.35

Code—Dedic

Packed one in a box.



Chain Drills

No. 718

Identical with No. 717 except has Master two jaw chuck which holds bit, round from $\frac{1}{8}$ to $\frac{1}{2}$ inch and No. 1 Morse Taper shanks.

Length with chuck $11\frac{1}{2}$ inches. Weight $4\frac{1}{2}$ lbs. Price, \$4.95

Code—Decur

Packed one in a box.



ROSE TOOLS, INC.

No. 719

The same construction as No. 717, except is furnished with Millers Falls chuck.

Chuck—three jaw, improved protected springs. Capacity $0\text{--}\frac{1}{2}$ in. round shanks.

Ball thrust bearing.

Frame, malleable iron, japanned black.

Chuck polished.

Length of chuck $11\frac{3}{4}$ inches. Weight $4\frac{1}{2}$ lbs. Price, \$5.20

Code—Declp

Packed one in a box.





Ratchet Drill

Nos. 10-12-14

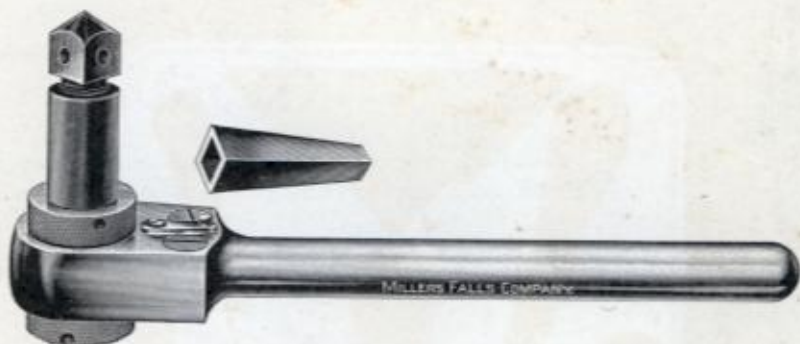

This tool is made for drilling in cramped quarters where it is impossible to use a breast or chain drill.

Ratchet can be used for either right or left hand work.

Socket hole holds shanks $\frac{5}{8}$ x $\frac{3}{8}$ x $1\frac{1}{2}$ inch. Extra socket to hold Bit shanks is furnished with each tool. Distance from top of feed screw to mouth of socket, four inches. Japanned handle, other parts polished with machinists' finish.

Nos.	10	12	14
Length of lever	10 in.	12 in.	14 in.
Weight each	2½ lbs.	3 lbs.	3½ lbs.
Price each	\$7.25	7.50	7.75
Code	Decol	Decoy	Decre

Packed one in a box.

ROSE TOOLS, INC.

File Handle

No. 448



While this handle holds perfectly files with tangs of all sizes and shapes, and is primarily a file handle, yet it also holds a variety of shanks of different shapes and sizes which do not exceed $\frac{3}{8}$ inch square or flat.

Malleable iron handle, japanned black. Screw and yoke white nicked.

Length $5\frac{1}{4}$ inches.

Weight each, 5 oz.

Price each, \$.30

Code—Scamp

Packed six in a box.

MILLERS FALLS AUTOMATIC TOOLS



ROSE TOOLS, INC.

AUTOMATIC TOOLS



This section contains information which is to a large degree new to our customers. For about three years we have been developing a line of automatic tools. It is now complete in every particular and includes three classes of tools as follows:

1. Automatic Drills.

For several years we have made a line of "push drills", the name of which will now be changed to "automatic drills". We now offer a new item No. 81 which is the best automatic drill we have ever manufactured. We also offer a new number of low priced drill No. 445. With the elimination of Nos. 3 and 4, we now have a line of five automatic drills which seem to answer all requirements in this field.

2. Ratchet Screw Drivers.

We offer herewith a complete line of ratchet screw drivers for every purpose. Our experience indicates that the market for ratchet screw drivers is as yet undeveloped. The consumer public as ROSE TOOLS, INC. not appreciate as yet the uses of this tool. Included in the list is our No. 55 "radio" ratchet screw driver with which we are able to furnish three socket wrenches which can be used with this screw driver in a unique manner.

3. Spiral Ratchet Screw Drivers.

Our line of spiral screw drivers is also complete. It consists of six numbers, including three numbers with automatic return feature. We also furnish chuck and drills for each size. The development of these screw drivers represents the most important addition to the Millers Falls line during the past three years.

It is our belief that these lines of automatic tools present features worthy of careful consideration from the consumer, dealer and jobber.

Automatic Drill

New

No. 81



The feature of this drill is the simplicity of design and construction of the magazine and handle.

By turning the knurled nut on the lower end of the handle, the handle is released and slides down on the frame, exposing all of the points. Selection of desired point is quickly made.

Knurled nut locks magazine securely and quickly so there is no chance of losing points.

Metal partitions in magazine keep each point in place. Size of point plainly marked against each compartment.

The handle is of convenient size to fit the hand comfortably.

Specifications

ROSE TOOLS, INC.

Eight drill points. Improved ball chuck.

Improved shell cannot be completely unscrewed and lost.

Handle handsomely knurled. Spiral nut of Tobin bronze.

Highly polished and nickered overall.

Length $10\frac{1}{2}$ in.

Weight each, 9 oz.

Price each, \$2.70

Code—Delsa

Packed one in a box.



Automatic Drill

No. 180

Improved

The main point of difference between this drill and No. 81 is in the method of removing the drills from the handle. Instead of the handle pulling down, the cap revolves permitting the drills to be tipped out into the hand. Pressing a catch releases the cap easily. Locks securely.

Specifications

Improved ball chuck holds with positive grip the eight specially notched points supplied with drill.

Steel handle, handsomely knurled.

Center nut, Tobin bronze, exceptionally long wearing.

Brass spirals. Polished and nickled over all.

Length $10\frac{1}{2}$ inches.

Weight each, 10 oz.

Price each, \$2.65

Code—Deser

Packed one in a box.

Improved

Automatic Drill



No. 79

This drill is identical with No. 180, except that a portion of the handle is of stained hardwood, shaped to give a firm, comfortable grip.

Specifications

Improved ball chuck holds with positive grip the eight specially notched points supplied with drill.

Steel handle, ~~ROSE TOOLS, INC.~~led.

Center nut, Tobin bronze, exceptionally long wearing.

Brass spirals. Polished and nickered over all.

Length $10\frac{1}{2}$ in.

Weight each, 10 oz.

Price each, \$2.45

Code—Desti

Packed one in a box.

Pocket Drill

No. 8

This drill is unique in design, and is different from any other automatic drill made. As its name implies, it can be carried in the pocket, ready for use, any time, anywhere.

When not in use, the chuck tube telescopes into the handle and is locked by slipping the knurled ring over a pin on the plunger.

It can be used in places inaccessible to the ordinary automatic drill, because it is three inches shorter even when extended.

When compressed it can be used as a screw driver for light work. A screw driver point is furnished for this purpose.

It is a compact, powerful little drill, handy for everyone to own.

Specifications

ROSE TOOLS, INC. with positive grip the eight specially notched points supplied with drill.

Brass handle, handsomely knurled.

Center nut Tobin bronze.

Spirals, hollow brass tubes.

Polished and nicked overall.

Length extended, $7\frac{1}{4}$ in. Compressed, $4\frac{1}{8}$ in.

Weight each, 12 oz.

Price each, \$3.75

Code—Deter

Packed one in a box.

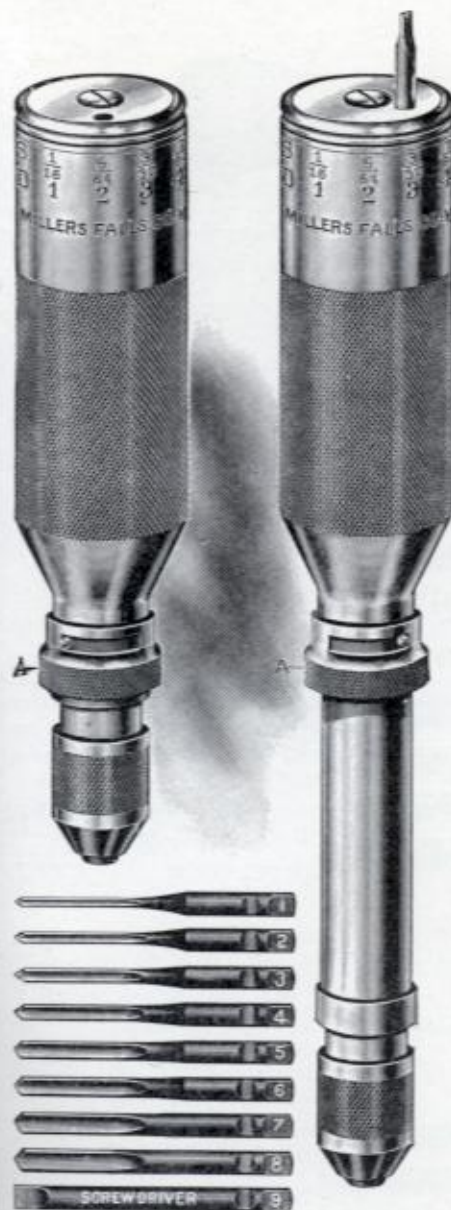



Automatic Drill

No. 445

New



Those who prefer a wooden handle will like this drill. The handle is of cocobolo wood and fits the hand comfortably. Handle is highly polished. Metal parts polished and nicked.

Chuck and other details same as No. 180. Eight drill points furnished in wooden box.

Length 11 inches.

Weight each, 11 oz.

Price each, \$2.00

Code—Detos

Packed one in a box.

Automatic Drill Points

New Style



ROSE TOOLS, INC.

This type of point fits all automatic drills illustrated on preceding pages. Packed one set or one dozen in a wooden box.

Price per set (8 points) \$.75

Code—Detot

Price per dozen \$1.25

Code—Detur

Old Style (Fluted Shanks)

These points with fluted shanks fit our older types of automatic drills.



Price per set
(8 points) \$.75

Code—Dezac

Price per doz. \$1.25

Code—Dezil



Spiral Ratchet Screw Drivers

New

Nos. 61-62-67



An improved spiral ratchet screw driver having spiral action for driving or withdrawing screws, right and left hand ratchet movements; and a device for making it a rigid screw driver.

These several actions are plainly marked on the shifter sleeve, which is quickly and easily operated. The spiral locking device is of new design, positive in action, and especially rigid. Clean cut knurling affords an easy grip when operating shifter sleeve and locking collar. Three screw driver blades of different sizes are furnished with each tool.

Directions for Use

- To Insert Blade**—Pull back the chuck sleeve—insert blade and turn it to the right as far as it will go.
- As Spiral Screw Driver**—Set shifter sleeve at "R" or "L".
- As Ratchet Screw Driver**—Close spiral, give locking collar a quarter turn. This locks the spiral. Set shifter sleeve at "R" or "L".
- As Rigid Screw Driver**—Close spiral. Set shifter sleeve at "O" and give locking collar a quarter turn.
- As Long Screw Driver**—Extend the spiral to extreme length. Set shifter sleeve at desired position, either ratchet or solid.

ROSE TOOLS, INC.

Specifications

Spiral or rod—steel, accurately machined.
Spiral Nuts—manganese bronze.
Ratchet Pawls—tool steel, hardened.
Handle—stained hardwood.

Blades—special analysis steel. Each blade individually tested.

All exposed metal parts highly polished and nickel plated. Handle is hand polished.

Nos.	67	61	62
Length, extended, with bit inserted	12 $\frac{5}{8}$ in.	20 $\frac{1}{2}$ in.	26 $\frac{1}{4}$ in.
Length, closed	9 $\frac{3}{8}$ in.	14 $\frac{1}{4}$ in.	17 $\frac{1}{4}$ in.
Weight, each (without blades)	8 oz.	1 lb.	1 lb., 8 oz.
Weight of three blades	1 $\frac{1}{2}$ oz.	2 $\frac{1}{4}$ oz.	3 oz.
Price each	\$2.30	3.10	4.15
Code	Gaily	Galax	Galbe

Packed one in a box.



Spiral Ratchet Screw Drivers

(Automatic Return)

New

Nos. 610-620-670.



These screw drivers are the same design as Nos. 61, 62 and 67 with the addition of a spring in the handle.

With this spring the tool works on the principle of an automatic drill in which the handle is pushed and quickly returns for the next stroke.

It is of particular advantage in driving screws in narrow places and for overhead work where it is impossible to hold on to the chuck.

ROSE TOOLS, INC.

When used in connection with chuck and drills (illustrated on next page) it offers a quick method of drilling small holes.

Specifications

The same as Nos. 61, 62 and 67, except for the spring in the handle.

Nos.	670	610	620
Length, extended, without blades	11-3/8 in.	18/9/16 in.	24-15/16 in.
Length, closed	8-1/8 in.	12-5/8 in.	16-1/8 in.
Weight, each, without blades	9 oz.	1 lb., 2 oz.	1 lb., 11 oz.
Weight of three blades	1 1/2 oz.	2 1/4 oz.	3 oz.
Price each	\$2.75	3.50	4.75
Code	<i>Galea</i>	<i>Galio</i>	<i>Galop</i>

Packed one in a box.



Chuck and Drills for Spiral Ratchet Screw Drivers

New

Nos. 6100-6200

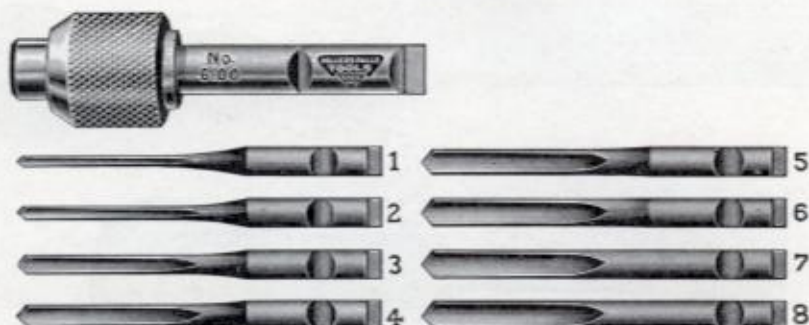

No. 6700



ROSE TOOLS, INC.

By the use of this chuck and drills a spiral ratchet screw driver is quickly converted into an efficient automatic drill for boring small holes. It adds much to the utility of these tools at a slight additional expense.

Drills can be changed without removing chuck from screw driver.

Specifications

Improved ball chuck, which grips securely the specially notched drill points.

Operates the same as when driving screws.

Chuck knurled and highly polished overall.

Nos.	For use with Screw Drivers Nos.	No. of drills and sizes	Weight	Price	Code
6700	67 and 670	3-1/16 in.-3/32 in. inc.	2 oz.	\$.45	Gamut
6100	61 and 610	8-1/16 in.-11/64 in. inc.	3 oz.	.95	Gamic
6200	62 and 620	8-1/16 in.-11/64 in. inc.	4 oz.	.95	Gamoz

Chuck and drills packed in round wooden box.



Ratchet Screw Drivers

No. 63

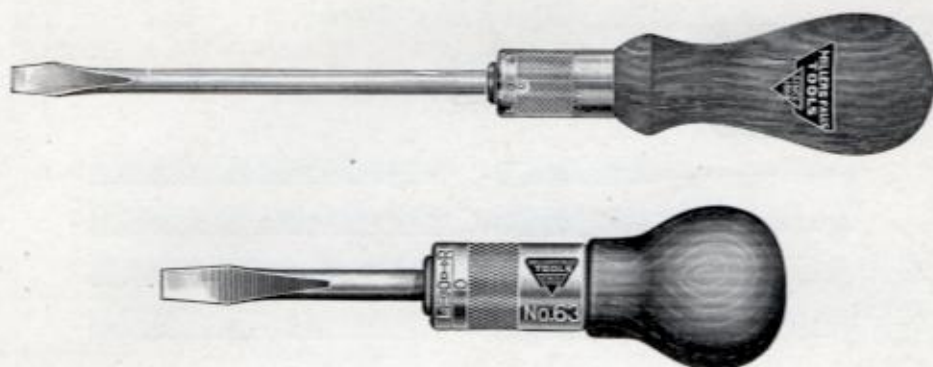

Those who have frequent use for a screw driver will find this ratchet type much easier, speedier and more convenient than the ordinary driver.

The ratchet operates smoothly, noiselessly and without friction, and is so constructed that the mechanism cannot get bent, broken or out of order.

It is a compact, strong tool, well proportioned and handsomely finished.

(Small illustration shows 2 in. driver. Other lengths like larger cut.)

ROSE TOOLS, INC. Specifications

Ratchet operates by means of cam in rear of shifter sleeve, self-locking on pawls. Ratchets either to right or left by turning shifter ring. Set at zero for solid screw driver.

Ratchet Pawls—tool steel. Ratchet Springs—spring steel. Ratchet Frame—cold rolled steel.

Blade—highest quality screw driver steel, hardened and tempered.

Handle—hardwood, highly polished. Shaped to conform to the hand. Thumb rest at lower end.

Exposed metal parts polished and nickel plated.

(6 in. and 8 in. drivers are of heavier design throughout).

Lengths	2 in.	3 in.	4 in.	5 in.	6 in.	8 in.
Weight each	3 oz.	4 oz.	5 oz.	6 oz.	8 oz.	9 oz.
Price each	\$.70	.80	.90	1.00	1.10	1.25
Code	Ganga	Ganil	Gaper	Garry	Garth	Garum

Packed six in a box



"Radio" Ratchet Screw Driver

No. 55

New



This screw driver is particularly adapted for radio, electrical and other light work where small screws are used.

A feature is the knurled collar which is part of the blade and which makes possible easy, rapid work.

The thumb and finger ratchet the blade by means of this collar, while the handle rests securely in the hand with pressure against the screw to prevent its wobbling. Screw is quickly tightened by turning the handle.

Ratchets either to right or left by turning shifter ring. Set at zero for solid screw driver.

Specifications

Blade—Cabinet type. Highest quality special screw driver steel. Hardened and tempered. 3/16 in. diameter.

Ratchet Pawls—tool steel. Ratchet Springs—spring steel.

Ratchet Frame—cold rolled steel.

Handle—stained hardwood, polished. Inserted ferrule to prevent splitting.

Exposed Metal Parts—polished and nickel plated.

Length of blades	2 in.	3 in.	4 in.	5 in.	6 in.
Length overall	5 in.	6 in.	7 in.	8 in.	9 in.
Weight each	3 oz.	3 oz.	3 oz.	4 oz.	4 oz.
Price each	\$.75	.80	.85	.90	.95
Code	Gatch	Gater	Gatha	Gacuy	Gaudy

Packed six in a box.

ROSE TOOLS, INC.

"Radio" Socket Wrench Set

No. 550

New



Set consists of three sockets which fit over the blade of our No. 55 Radio Ratchet Screw Driver, converting it into an efficient ratchet socket wrench to fit the small nuts used in radio construction. Special milled slot prevents socket from turning on the blade.

Specifications

Steel, case hardened. Mottled finish.

For 1/4 inch, 5/16 inch, and 3/8 inch hex machine screw nuts.

Can be used with any length No. 55 Screw Driver shown at top of page.

Price per set, \$.50

Code—Gauzt

Weight per set, 2 oz.

Packed each set in a box, six boxes to a carton.

Ratchet Screw Driver

New

No. 59

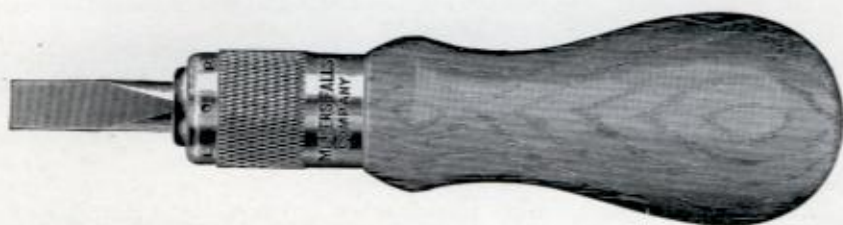

This new Millers Falls Screw Driver is made especially for electricians, gunsmiths, mechanics, and others whose work demands a screw driver more rugged than the regular type.

The ratchet mechanism is so constructed that it cannot get bent, broken or out of order. It operates smoothly, and without friction. ROSE TOOLS, INC.

Specifications

Ratchet operates by means of cam in rear of shifting sleeve, self locking on pawls. Ratchets either to right or left by turning shifter ring. Set at zero for solid screw driver.

Ratchet Pawls—tool steel. Ratchet Springs—spring steel. Ratchet Frame—cold rolled steel.

Blade—highest quality screw driver steel, hardened and tempered.

Handle—hardwood, highly polished. Shaped to conform to the hand. Thumb rest at lower end.

Exposed metal parts polished and nickel plated.

Length of blade, $1\frac{1}{8}$ inches.

Length overall, $6\frac{1}{4}$ inches.

Weight each, 6 oz.

Code—Gawby

Price each, \$1.00

Packed six in a box.



Screw Drivers

No. 66



A handy little tool with a multitude of uses about the home, office or automobile. Blade is knurled to give firm grip in starting screws. Blade positively will not turn in handle.

Cocobolo handle. Polished steel blade.

Length of blade	1½ in.	2½ in.	3½ in.
Weight per dozen	7 oz.	9 oz.	10 oz.
Price per dozen	\$2.10	2.20	2.25
Code	<i>Gemel</i>	<i>Genet</i>	<i>Genie</i>

Packed twelve in a box.

No. 75



A light, well-made, screw driver adapted for delicate work. The blades are of special screw driver steel, forged, hardened and tempered. The blades are ground on the side edges as well as on the edge and flats, so will follow into a hole with diameter same size as round of blade.

Blade securely fastened into handle.

Cocobolo handle. Polished blade, nickel plated ferrule.

Length of blade	2½ in.	3½ in.
Weight per dozen	8 oz.	10 oz.
Price per dozen	\$2.55	2.65
Code	<i>Genly</i>	<i>Genus</i>

ROSE TOOLS, INC.

Packed twelve in a box.

Screw Driver Bits

Nos. 4-10



A hammer forged bit superior to the ordinary tool of this type. None but high grade steel is used in its manufacture and special attention is given to the hardening and tempering.

The points are carefully formed and accurately fit the slots for which they are intended.

4 in. long overall.

No.	4	5	6	8	10
Width of point inches	4/16	5/16	6/16	8/16	10/16
For screws Nos.	6 to 8	8 to 12	12 to 16	16 to 20	20 to 24
Weight per dozen	9 oz.	12 oz.	1 lb.	1¼ lbs.	1½ lbs.
Price per dozen	\$2.95	3.00	3.15	3.30	3.45
Code	<i>Gerah</i>	<i>Gerbe</i>	<i>Gesse</i>	<i>Getup</i>	<i>Ghast</i>

Packed six in a box.



Ratchet Screw Driver Display

No. 700

This new display is made entirely of metal and is hand-somely finished in four colors.

The fixture holds: One No. 63—2 in. Ratchet screw driver.
 One No. 63—4 in. Ratchet screw driver.
 One No. 55—3 in. Ratchet screw driver.
 One No. 55—6 in. Ratchet screw driver.
 One No. 59— Ratchet screw driver.

It is given without charge with an order for four of each size of No. 63 and No. 55 and two of No. 59, making a total of eighteen screw drivers. Neatly packed, each number in an individual box—in one large box.

Made entirely of metal.



Specifications

Height, 11 $\frac{3}{4}$ in. Weight with one each screw driver, 2 $\frac{1}{4}$ lbs.
 Width, 9 $\frac{3}{4}$ in. Shipping weight with screw drivers listed above, 6 $\frac{3}{4}$ lbs.
 Depth, 5 $\frac{1}{2}$ in.

Code—Geozy

(SEE CUT ON COLOR INSERT)
 Each display packed in an individual carton.

Screw Driver Sets

No. 660

No. 66 screw drivers sell readily from this neat display card. Set comprises four each 1 $\frac{1}{2}$, 2 $\frac{1}{2}$, and 3 $\frac{1}{2}$ inch, attractively mounted on heavy cardboard, covered with dark green paper.

ROSE TOOLS, INC.

Weight per set, 1 lb.

Price per set, \$2.55

Code—Geode

Each set wrapped singly in heavy paper.



No. 750

This set is made up of six each 2 $\frac{1}{2}$ and 3 $\frac{1}{2}$ inch No. 75 screw drivers. Card is of same material as No. 660 set.

Takes up but little room and insures a rapid turnover on these tools.

Weight per set, 1 lb.

Price per set, \$2.85

Code—Geoid

Each set wrapped singly in heavy paper.

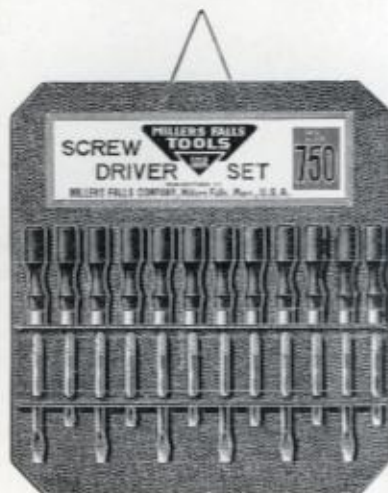



TOOL HOLDERS

Millers Falls tool holders are built to withstand the hard usage that is generally given to this type of tool.

The handles on Nos. 1, 4 and 5 are of the finest cocobolo, shaped to fit the hand comfortably, and with exceptionally smooth, highly polished surfaces. Threads on screw caps are deep and clean cut.

The socket and shell threads are carefully cut in order to mesh perfectly and insure holding the shell tight against the jaws.

The tools are of high grade steel carefully tempered, and honed to a keen cutting edge.



Tool Holders

No. 1



Specifications

Handle—Cocobolo. Highly polished.
 Chuck and jaws nickel plated.
 Length of handle 6 inches.

Length of tools $1\frac{3}{4}$ inches.
 Number of tools 20.

Weight each, $\frac{1}{2}$ lb.

Price each, \$1.90

Code—*Fairy*

Packed six in a box.

No. 4



Specifications

Same finish as No. 1.
 Length of handle $6\frac{1}{4}$ inches. ROSE TOOLS, INC.

Length of tools $2\frac{1}{4}$ inches.
 Number of tools 10.

Weight each, 10 oz.

Price each, \$2.40

Code—*Fecks*

Packed one in a box.

No. 5



Specifications

Same finish as No. 1.
 Length of handle $7\frac{1}{2}$ inches.

Length of tools 4 inches.
 Number of tools 10.

Weight each, 14 oz.

Price each, \$3.30

Code—*Feeze*

Packed one in a box.



Tools for Tool Holders

No. 1



No. 4



ROSE TOOLS, INC.

No. 9





Tool Holders

No. 1



Specifications

Handle—Cocobolo. Highly polished.
 Chuck and jaws nickel plated.
 Length of handle 6 inches.

Length of tools $1\frac{3}{4}$ inches.
 Number of tools 20.

Weight each, $\frac{1}{2}$ lb.

Price each, \$1.90

Code—*Fairy*

Packed six in a box.

No. 4



Specifications

Same finish as No. 1.
 Length of handle $6\frac{1}{4}$ inches.
 Weight each, 10 oz.

ROSE TOOLS, INC.

Length of tools $2\frac{1}{4}$ inches.
 Number of tools 10.

Price each, \$2.40

Code—*Fecks*

Packed one in a box.

No. 5



Specifications

Same finish as No. 1.
 Length of handle $7\frac{1}{2}$ inches.
 Weight each, 14 oz.

Length of tools 4 inches.
 Number of tools 10.

Price each, \$3.30

Code—*Feeze*

Packed one in a box.

Packed one in a box.

Code—Felly

Price each, \$2.30

Weight each, 9 oz.

Handle—steel, handsomely knurled. Hollow end with screw cap.
 Chuck—knurled. Jaws—hardened steel. Nickel plated overall.
 Length of handle 5 inches. Length of tools $2\frac{1}{4}$ inches. Number of tools 10.

Specifications

This tool is made entirely of steel, and for this reason the handle can be made smaller. Because of its size can be conveniently carried in the pocket. Is handy for hammering small objects such as tacks and nails.
 The tools are made of high grade steel, carefully tempered, and honed to a fine cutting edge. The chuck holds the shanks with a vise-like grip.



ROSE TOOLS, INC.

No. 600

Tool Holder**MILLERS FALLS COMPANY**



CHUCKS

Millers Falls Chucks bear an enviable reputation for accuracy and serviceability.

For these reasons they are in demand wherever chucks are used.

There are a number of tools and machines made by other manufacturers which have Millers Falls Chucks as standard equipment.

The jaws which are the vital part of the tool are machined and ground with precision, and grip round shanks tightly and accurately. They are carefully adjusted into the socket and close by pressure of the spindle.

The springs which control the jaws are situated far down in the base where they cannot possibly be injured by a drill shank. These springs are an improved type which press the jaws outward against the shell—making it much easier to insert the drill shanks.

The chuck shell is of steel, and is shaped to give a firm grip in tightening.

All styles are handsomely knurled and polished.

They are guaranteed to give satisfaction.



Chucks

No. 4

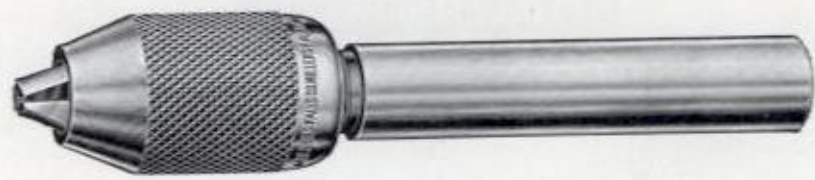

Specifications

Capacity 0-3/16 inch round shanks.
Dimensions of shank 2 1/2 x 1/2 inch.

Outside diameter 1 inch.

Weight, 6 oz.

Code—Eager

Price, \$1.30

Packed one in a box.

(Furnished with shank flattened for set screw without extra charge.)

Without Shank

Price, \$.95

Code—Eared

No. 5



Specifications

Capacity 0-1/4 inch round shanks.
Dimensions of shank 2 1/2 x 1/2 inch.

Outside diameter 1 inch.

Weight, 7 oz.

Code—Early

Price each, \$1.70

Packed one in a box.

(Furnished with shank flattened for set screw without extra charge.)

Without Shank

Price each, \$1.35

Code—Earsh

With Shank 41/64 inch.

Price, \$1.70

Code—Earth



Chucks

No. 6



Specifications

Capacity 0- $\frac{3}{8}$ inch round shanks.
Dimensions of shank 2 $\frac{1}{2}$ x $\frac{1}{2}$ inch.

Outside diameter 1 $\frac{1}{4}$ inch.

Weight 10 oz.

Code—Easel

Price, \$2.05

Packed one in a box.

(Furnished with shank flattened for set screw without extra charge.)

Without Shank

Price, \$1.65

Code—Eastr

With Shank $\frac{41}{64}$ inch

Price, \$2.05

Code—Eater

No. 7



Specifications

Capacity 0- $\frac{1}{2}$ inch round shanks.
Dimensions of shank 2 $\frac{1}{2}$ x $\frac{1}{2}$ inch.

Outside diameter 1 $\frac{1}{2}$ inch.

Weight 17 oz.

Code—Eagle

Price, \$2.80

Packed one in a box.

(Furnished with shank flattened for set screw without extra charge.)

Without Shank

Price, \$2.30

Code—Eaves

With Shank $\frac{41}{64}$ inch.

Price, \$2.80

With Shank $\frac{7}{8}$ inch.

Price, \$2.80

Code—Eazel

Code—Eazel



Chucks

These Chucks have the same body as Nos. 5, 6 and 7. The shanks only are different. They are of the bit shank pattern which permits use in bit braces, breast drills, and other tools, which hold this type of shank.

No. 15



Capacity 0- $\frac{1}{4}$ inch. Outside diameter of chuck 1 inch.
Weight 6 oz.

Code—Eblis
Packed one in a box.

Price each, \$1.70

No. 16



Capacity 0- $\frac{3}{8}$ inch. Outside diameter of chuck 1 $\frac{1}{4}$ inch.
Weight 10 oz.

ROSE TOOLS, INC.

Code—Ebony
Packed one in a box.

Price each, \$2.15

No. 17



Capacity 0- $\frac{1}{2}$ inch. Outside diameter of chuck 1 $\frac{1}{2}$ inch.
Weight 17 oz.

Code—Ecart
Packed one in a box.

Price each, \$2.80



Chucks With Taper Shanks



These Chucks are the same as Nos. 4, 5, 6 and 7, except have Taper Shanks. These shanks are accurately made and are according to Morse Standard. The length given is of taper only and does not include tang.

Specifications

Chuck No.	Taper No. 1		ROSE TOOLS, INC. No. 2		No. 3		No. 4	
	Price	Code	Price	Code	Price	Code	Price	Code
4	\$1.85	<i>Eccle</i>	\$2.00	<i>Echel</i>				
5	2.25	<i>Echin</i>	2.35	<i>Echoe</i>				
6	2.60	<i>Eckle</i>	2.75	<i>Eclat</i>	\$3.30	<i>Eclac</i>		
7	3.40	<i>Eclip</i>	3.55	<i>Ecoid</i>	4.10	<i>Ecolo</i>	\$4.95	<i>Ecphe</i>

No. 1 Taper is 2 1/8 in. long; largest diameter .475 in.; smallest diameter .369 in.

No. 2 Taper is 2 9/16 in. long; largest diameter .700 in.; smallest diameter .572 in.

No. 3 Taper is 3 3/16 in. long; largest diameter .938 in.; smallest diameter .778 in.

No. 4 Taper is 4 1/16 in. long; largest diameter 1.231 in.; smallest diameter 1.020 in.

When ordering it is essential to specify the number of Chuck as well as the size number of taper.



Lathe Chucks

No. 152

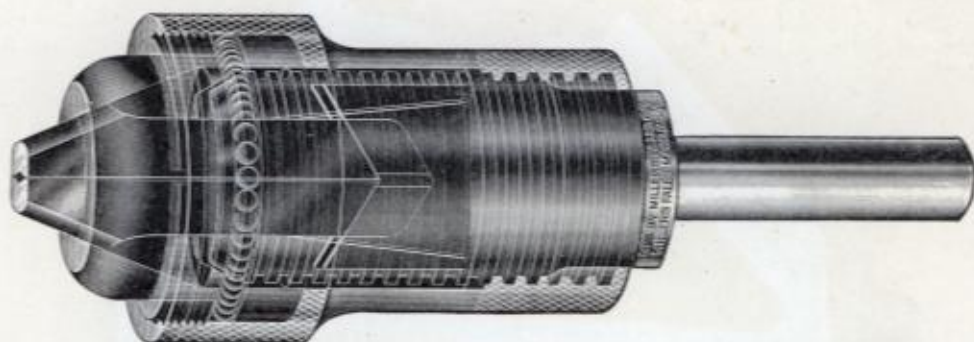

The feature of this Chuck is its extraordinary gripping power.

The inner shell or hood revolves with the jaws within the outer shell, thus eliminating practically all friction against the jaws. Ball bearings run between the inner hood and outer shell, which reduce this friction to a minimum. It is easily tightened or released without the use of a wrench.

Specifications

Capacity—bit shanks, round from $\frac{1}{8}$ to $\frac{1}{2}$ inch and No. 1 Morse taper shanks.

Jaws—hardened steel. Parallel milling grips along entire length.

Hardened adjusting screw to take up wear on balls. Check nut prevents loosening.

Polished and nickel plated. Length overall $5\frac{3}{4}$ inch. Outside diameter of chuck $1\frac{1}{4}$ inch.

Dimensions of shank $2\frac{1}{2}$ x $\frac{1}{2}$ inch.

Weight each, 20 oz.

Price each, \$2.65

Code—Ecvad

Furnished with shanks $15/16$ (Code—Ectol) or $41/64$ in. (Code—Ectyp) in diameter without extra charge.

Special straight, or taper shanks, to order 50c extra.

Packed one in a box.

ROSE TOOLS, INC.
No. 152



This is our well-known Master Chuck, which is so popular on our No. 732 series of braces, equipped with shank for lathe purposes.

Specifications

Capacity—bit shanks, round from $\frac{1}{8}$ to $\frac{1}{2}$ inch and No. 1 Morse taper shanks.

Jaws—hardened steel. Same patent milling as on No. 152. Polished overall.

Length overall 5 inch. Outside diameter of chuck $1\frac{1}{2}$ inch.

Dimensions of shank $2\frac{1}{2}$ x $\frac{1}{2}$ inch.

Weight each, 1 lb.

Price each, \$2.05

Code—Edict

Furnished with shanks $15/16$ in. (Code—Edify) or $41/64$ in. (Code—Educt) in diameter without extra charge.

Special straight or taper shanks, to order 50c extra.

Packed one in a box.

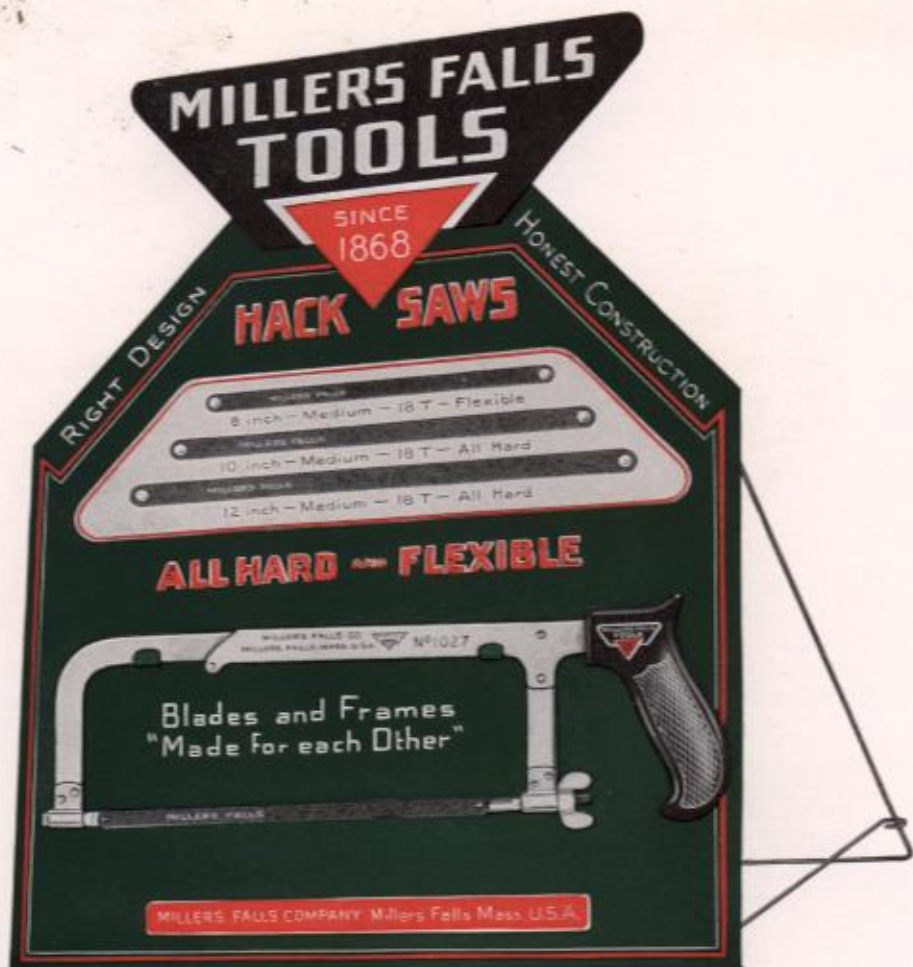

MILLERS FALLS HACK SAW DISPLAY, NO. 1000

ROSE TOOLS, INC.

Here is another Millers Falls display—designed to put Millers Falls Hack Saws up front on the selling line.

Its selling value is further enhanced by No. 1027 (the original pistol grip) hack saw frame displayed with the saws. One helps to sell the other.

The stand is furnished without charge with an order for three gross of Millers Falls Hack Saws of the following sizes:

$\frac{1}{2}$ gross 8 in. 2 gross 10 in. $\frac{1}{2}$ gross 12 in.
and four only No. 1027 frames.

It is light enough to stand on your counter—attractive enough to place in a prominent position in any part of your store.

SPECIFICATIONS

Height—21 $\frac{1}{4}$ inches to top of Trade Mark.

Width—17 inches.

Depth—1 $\frac{1}{4}$ inches.

Made entirely of metal.

Hinged Back.

Illustration shows actual colors.

Weight with Frame—6 lbs.

Shipping weight with three gross Saws (listed above) and four Frames—56 lbs.

One hundred Millers Falls hack saw leaflets with each display.

Code—Immer

EACH STAND PACKED IN AN INDIVIDUAL CARTON.



HACK SAW BLADES

For over forty years the Millers Falls Company has marketed hack saw blades. In August, 1920, we became manufacturers as well as distributors of our own hack saw blades. At that time we acquired complete control of the West Haven Mfg. Co. of West Haven, Conn., which for twenty-four years had successfully made the "Universal" hack saw (often called the "Globe" saw because of the Globe stamp used as a trade mark). This blade was of recognized sterling quality. To the "Universal" brand we added a blade under our own name "Millers Falls".

Both are made of a special analysis of tungsten steel, the result of many years of study of hack sawing problems.

The teeth are milled, which insures a sharp, solid cutting edge. The style of set is patented, and is unexcelled for accuracy and clearance. The saws cut freely until worn dull. Each blade is hardened *individually*. This insures a uniformity impossible in the common method of hardening in lots of four to twelve.

The hand blades are made in both all hard and flexible types—the power blades, all hard only. The range of lengths, widths, gauges and teeth cuts, cover every possible hack sawing requirement.

The Millers Falls standard has ever been set high for precision, honesty and fine design in tool making. Confidence has long been shown by the trade in stocking and distributing Millers Falls tools. The same confidence can well be placed in Millers Falls and Universal hack saws.

MILLERS FALLS COMPANY

MILLERS FALLS
TOOLS

MILLER FALLS Hand Hack Saws

All Hard (Tungsten)

MILLERS FALLS

No.	Length	Width	Gauge	Teeth	Price per Gross	Code	No. in Box	Weight per Gross
1	8	7/16	025-23	14	\$8.00	<i>Haber</i>	1/2 gross	3 1/2 lbs.
2	9	7/16	025-23	14	9.00	<i>Habit</i>	1/2 gross	4 lbs.
3	10	1/2	025-23	14	10.00	<i>Hable</i>	1/2 gross	5 lbs.
4	11	1/2	025-23	14	11.00	<i>Hades</i>	1/2 gross	5 1/2 lbs.
5	12	9/16	025-23	14	12.00	<i>Hadst</i>	1/2 gross	7 lbs.
6	12	5/8	028-22	14	16.80	<i>Hafiz</i>	1/2 gross	9 lbs.
7	14	5/8	028-22	14	19.44	<i>Haint</i>	1/2 gross	11 lbs.
11	8	7/16	025-23	18	8.00	<i>Hairs</i>	1/2 gross	3 1/2 lbs.
12	9	7/16	025-23	18	9.00	<i>Hamal</i>	1/2 gross	4 lbs.
13	10	1/2	025-23	18	10.00	<i>Hamer</i>	1/2 gross	5 lbs.
14	11	1/2	025-23	18	11.00	<i>Hanap</i>	1/2 gross	5 1/2 lbs.
15	12	9/16	025-23	18	12.00	<i>Hance</i>	1/2 gross	7 lbs.
16	12	5/8	028-22	18	16.80	<i>Handy</i>	1/2 gross	9 lbs.
17	14	5/8	028-22	18	19.44	<i>Hanse</i>	1/2 gross	11 lbs.
21	8	7/16	025-23	24	8.00	<i>Hanum</i>	1/2 gross	3 1/2 lbs.
22	9	7/16	025-23	24	9.00	<i>Haplo</i>	1/2 gross	4 lbs.
23	10	1/2	025-23	24	10.00	<i>Happy</i>	1/2 gross	5 lbs.
24	11	1/2	025-23	24	11.00	<i>Hardi</i>	1/2 gross	5 1/2 lbs.
25	12	9/16	025-23	24	12.00	<i>Harem</i>	1/2 gross	7 lbs.
31	8	7/16	025-23	32	8.00	<i>Harot</i>	1/2 gross	3 1/2 lbs.
32	9	7/16	025-23	32	9.00	<i>Harmo</i>	1/2 gross	4 lbs.
33	10	1/2	025-23	32	10.00	<i>Harpa</i>	1/2 gross	5 lbs.
34	11	1/2	025-23	32	11.00	<i>Harry</i>	1/2 gross	5 1/2 lbs.
35	12	9/16	025-23	32	12.00	<i>Harsh</i>	1/2 gross	7 lbs.

ROSE TOOLS, INC.

All hard blades are recommended for general all around work and are always furnished unless flexible are specified.

Suggestions for Using Hand Blades

Insert blade in frame with teeth pointing away from operator.

Strain blade tightly.

Bear down on forward stroke sufficiently to avoid sliding saw over the work.

Sliding over the surface glazes the cutting edges and dulls the saw.

Always lift the blade on the return stroke. Failure to do so results in rubbing action and rapid dulling.

Retighten blade after the first few strokes. This prevents wobbling and crooked cutting.

Thirty-five to forty strokes per minute is fast enough. Too rapid cutting draws the temper and ruins the blade.

The chart on page 109 explains the use of each blade.

List Prices above apply only in the United States and Canada.



MILLERS FALLS Hand Hack Saws Flexible (Tungsten)

MILLERS FALLS



No.	Length	Width	Gauge	Teeth	Price per Gross	Code	No. in Box	Weight per Gross
41	8	7/16	025-23	14	\$8.00	<i>Heads</i>	1/2 gross	3 1/4 lbs.
42	9	7/16	025-23	14	9.00	<i>Heald</i>	1/2 gross	3 1/2 lbs.
43	10	1/2	025-23	14	10.00	<i>Heard</i>	1/2 gross	4 3/4 lbs.
44	11	1/2	025-23	14	11.00	<i>Heart</i>	1/2 gross	5 1/4 lbs.
45	12	9/16	025-23	14	12.00	<i>Heath</i>	1/2 gross	7 lbs.
51	8	7/16	025-23	18	8.00	<i>Heave</i>	1/2 gross	3 1/4 lbs.
52	9	7/16	025-23	18	9.00	<i>Hebra</i>	1/2 gross	3 1/2 lbs.
53	10	1/2	025-23	18	10.00	<i>Hecto</i>	1/2 gross	4 3/4 lbs.
54	11	1/2	025-23	18	11.00	<i>Hedge</i>	1/2 gross	5 1/4 lbs.
55	12	9/16	025-23	18	12.00	<i>Helio</i>	1/2 gross	7 lbs.
61	8	7/16	025-23	24	8.00	<i>Helix</i>	1/2 gross	3 1/4 lbs.
62	9	7/16	025-23	24	9.00	<i>Helop</i>	1/2 gross	3 1/2 lbs.
63	10	1/2	025-23	24	10.00	<i>Helve</i>	1/2 gross	4 3/4 lbs.
64	11	1/2	025-23	24	11.00	<i>Hemat</i>	1/2 gross	5 1/4 lbs.
65	12	9/16	025-23	24	12.00	<i>Hemor</i>	1/2 gross	7 lbs.
71	8	7/16	025-23	32	8.00	<i>Hence</i>	1/2 gross	3 1/4 lbs.
72	9	7/16	025-23	32	9.00	<i>Henry</i>	1/2 gross	3 1/2 lbs.
73	10	1/2	025-23	32	10.00	<i>Hepta</i>	1/2 gross	4 3/4 lbs.
74	11	1/2	025-23	32	11.00	<i>Heron</i>	1/2 gross	5 1/4 lbs.
75	12	9/16	025-23	32	12.00	<i>Herse</i>	1/2 gross	7 lbs.

Flexible blades differ from "all hard" in that the teeth only are hardened.

Recommended for use particularly on thin sections of soft materials, both sheet and tubing.

Superior to the "all hard" for use in out of the way places, and when frame must be held in other than a normal position.

Electricians, plumbers and steam fitters will find this type of blade more economical than "all hard".

Special Flexible Suggestions

Flexible blades should be strained tighter in frame than "all hard".

Because they stretch more readily tension should be increased frequently while in use.

When starting a new blade in an old cut, give work a quarter turn if possible. This will overcome the binding due to wider set of new blade.

The chart on page 109 explains the use of each blade.

List Prices above apply only in the United States and Canada.

MILLERS FALLS COMPANY



MILLERS FALLS Power Hack Saws All Hard (Tungsten)

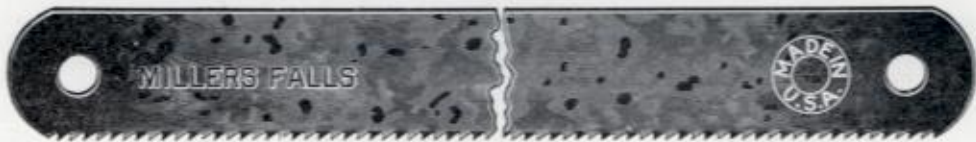

No.	Length	Width	Gauge	Teeth	Price per Gross	Code	No. in Box	Weight per Gross
100	10	3/4	049-18	10	\$24.72	Hiber	1/3 gross	15 1/2 lbs.
120	12	3/4	032-21	14	21.36	Hicup	1/2 gross	11 1/2 lbs.
121	12	3/4	049-18	10	28.92	Hidden	1/2 gross	17 3/4 lbs.
122	12	3/4	049-18	14	28.92	Hiero	1/3 gross	17 3/4 lbs.
123	12	1	049-18	10	37.92	Hifer	1/4 gross	24 1/2 lbs.
124	12	1	049-18	14	37.92	Higre	1/4 gross	24 1/2 lbs.
125	12	5/8	032-21	14	17.88	Hinge	1/2 gross	10 lbs.
126	12	5/8	032-21	18	17.88	Hilly	1/2 gross	10 lbs.
140	14	3/4	032-21	14	24.36	Hilum	1/2 gross	13 3/4 lbs.
141	14	3/4	049-18	10	33.12	Hindi	1/4 gross	20 lbs.
142	14	3/4	049-18	14	33.12	Hippa	1/4 gross	20 lbs.
143	14	1	049-18	10	43.56	Hirer	1/4 gross	28 lbs.
144	14	1	049-18	14	43.56	Histo	1/4 gross	28 lbs.
145	14	1	065-16	10	50.88	Hitch	1/4 gross	36 lbs.
160	16	1	049-18	10	49.08	Hiram	1/4 gross	32 lbs.
161	16	1	049-18	14	49.08	Hithe	1/4 gross	32 lbs.
162	16	1	065-16	10	56.88	Hives	1/4 gross	42 1/2 lbs.
170	17	3/4	032-21	14	29.04	Horrd	1/6 gross	17 lbs.
171	17	1	049-18	10	51.72	Hobby	1/4 gross	34 lbs.
172	17	1	049-18	10	51.72	Hobit	1/4 gross	34 lbs.
173	17	1	065-16	10	59.52	Hocco	1/4 gross	45 lbs.
180	18	1	049-18	10	54.36	Hocus	1/4 gross	35 lbs.
181	18	1	065-16	10	62.04	Hoggy	1/4 gross	47 lbs.
182	18	1 1/2	065-16	8	90.24	Hoist	1/12 gross	74 lbs.
210	21	1	049-18	10	62.04	Hoker	1/4 gross	43 lbs.
211	21	1	065-16	10	70.44	Holly	1/4 gross	56 lbs.
240	24	1	049-18	10	70.32	Holmi	1/4 gross	47 lbs.
241	24	1	065-16	10	79.32	Holos	1/4 gross	62 lbs.
242	24	1 1/2	065-16	6	119.04	Holce	1/12 gross	128 lbs.
243	24	1 1/2	065-16	8	119.04	Homer	1/12 gross	128 lbs.

ROSE TOOLS, INC.

14" and 17" power hack saws are 1/2" less to centers than length given. All other blades are true to lengths stated.

Too light a pressure allows saw to slide, dull quickly and without cutting effectively.

Rigidity is important. Wherever possible lock work securely in a vise.

Place work so that as much bearing as possible is provided for the saw.

The use of cutting solutions will greatly increase your output, and prolong the life of the blades

Cutting dry on light machines, run 50 strokes per minute.

Cutting with solution on medium and heavy machines, 100 strokes per minute are recommended for soft machinery steel and wrought iron. Seventy to eighty strokes for hard tool or annealed steel.

Do not cut unannealed steel.

The chart on page 109 explains the use of each blade.

List Prices above apply only in the United States and Canada.



MILLERS FALLS Hack Saw Chart

In order to obtain the maximum cutting from a hack saw blade, and a resulting minimum sawing cost, it is imperative that the proper saw is used.

In hand blades the number of teeth per inch is the chief consideration; in power blades the width and gauge also are essential factors.

The chart below illustrates clearly and concisely the correct blade to use on any given material. This chart is made up from actual tests made in our own plant and will, if followed, reduce direct sawing costs as well as the cost of saws.

Length in Inches	Width in Inches	Thickness	HAND ALL, HARD Order by Numbers Below				HAND FLEXIBLE Order by Numbers Below				List Price per Gross
			Brass, Copper, Soft Steel, Cast Iron, Aluminum	Iron Pipe, Tool Steel, Light Angle Iron	Drill Rod, Medium Tubing, Sheet Metals	Thin Tubing, Electric Casings, Thin Sheet Metals	Brass, Copper, Soft Steel, Cast Iron, Aluminum	Iron Pipe, Tool Steel, Light Angle Iron	Drill Rod, Medium Tubing, Sheet Metals	Thin Tubing, Electric Casings, Thin Sheet Metals	
			14 Teeth	18 Teeth	24 Teeth	32 Teeth	14 Teeth	18 Teeth	24 Teeth	32 Teeth	
8	7/16	23 Ga.—.025"	No. 1	No. 11	No. 21	No. 31	No. 41	No. 51	No. 61	No. 71	\$8.00
9	7/16	23 Ga.—.025"	No. 2	No. 12	No. 22	No. 32	No. 42	No. 52	No. 62	No. 72	9.00
10	1/2	23 Ga.—.025"	No. 3	No. 13	No. 23	No. 33	No. 43	No. 53	No. 63	No. 73	10.00
11	1/2	23 Ga.—.025"	No. 4	No. 14	No. 24	No. 34	No. 44	No. 54	No. 64	No. 74	11.00
12	9/16	23 Ga.—.025"	No. 5	No. 15	No. 25	No. 35	No. 45	No. 55	No. 65	No. 75	12.00
12	5/8	22 Ga.—.028"	No. 6	No. 16							16.80
14	5/8	22 Ga.—.028"	No. 7	No. 17							19.44

POWER BLADES (Order by Numbers Below)

21 Ga.—.032 x 3/4 For Light Power Mach.			18 Ga.—.049 x 3/4 For Medium Power Mach.			18 Ga.—.049 x 1" For Heavy Power Mach.			16 Ga.—.065 For Extra Heavy Power Mach.			
Length in Inches	Annealed Tool Steel, Soft Steel	List Price per Gross	Heavy Angle Iron, Iron Pipe, Cast Iron	Tool Steel, Hard Metals	List Price per Gross	Soft Steel, Annealed Tool Steel, Brass, Copper	Steel Tubing, Tool Steel, Light Angle Iron	List Price per Gross	Soft Steel, Large Work	Machinery Steel, Steel Rails	Tool Steel, Angle Iron, Small Work	List Price per Gross
10			No. 100		\$24.72							
12	No. 120	\$21.36	No. 121	No. 122	28.92	No. 123	No. 124	\$37.92				
12	No. 125	17.88										
12	No. 126*	17.88										
14	No. 140	24.36	No. 141	No. 142	33.12	No. 143	No. 144	43.56			No. 145	\$50.88
16						No. 160	No. 161	49.08			No. 162	56.88
17	No. 170	29.04				No. 171	No. 172	51.72			No. 173	59.52
										No. 182		90.24
18						No. 180		54.36			No. 181	62.04
21						No. 210		62.04			No. 211	70.44
											No. 241	79.32
24						No. 240		70.32	No. 242	No. 243		119.04

* Has 18 teeth. Adapted especially for Thin Sections and Hard Tool Steel.

The above numbers apply to Millers Falls Blades, but the chart is applicable to Universal blades as well. Simply omit the blade number and note length, width, gauge and teeth.

List Prices above apply only in the United States and Canada.

MILLERS FALLS COMPANY



UNIVERSAL Hand Hack Saws

All Hard (Tungsten)



Length	Width	Gauge	Teeth	Price Per Gross	Code	No. in Box	Weight per Gross
8	7/16	23-025	14	\$8.00	<i>Huble</i>	1/2 gross	3 1/4 lbs.
9	7/16	23-025	14	9.00	<i>Huckr</i>	1/2 gross	3 1/2 lbs.
10	1/2	23-025	14	10.00	<i>Huffy</i>	1/2 gross	4 3/4 lbs.
10	5/8	22-028	14	14.40	<i>Huger</i>	1/2 gross	7 3/4 lbs.
11	1/2	23-025	14	11.00	<i>Hulch</i>	1/2 gross	5 1/4 lbs.
12	9/16	23-025	14	12.00	<i>Hulki</i>	1/2 gross	7 lbs.
12	5/8	22-028	14	16.80	<i>Hullo</i>	1/2 gross	8 3/4 lbs.
14	5/8	22-028	14	19.44	<i>Human</i>	1/2 gross	9 3/4 lbs.
8	7/16	23-025	18	8.00	<i>Humbl</i>	1/2 gross	3 1/4 lbs.
9	7/16	23-025	18	9.00	<i>Humec</i>	1/2 gross	3 1/2 lbs.
10	1/2	23-025	18	10.00	<i>Humid</i>	1/2 gross	4 3/4 lbs.
10	5/8	22-028	18	14.40	<i>Humme</i>	1/2 gross	7 3/4 lbs.
11	1/2	23-025	18	11.00	<i>Humph</i>	1/2 gross	5 1/4 lbs.
12	9/16	23-025	18	12.00	<i>Humus</i>	1/2 gross	7 lbs.
12	5/8	22-028	18	16.80	<i>Hunch</i>	1/2 gross	8 3/4 lbs.
14	5/8	22-028	18	19.44	<i>Hunge</i>	1/2 gross	9 3/4 lbs.
8	7/16	23-025	24	8.00	<i>Hunks</i>	1/2 gross	3 1/4 lbs.
9	7/16	23-025	24	9.00	<i>Hunte</i>	1/2 gross	3 1/2 lbs.
10	1/2	23-025	24	10.00	<i>Huras</i>	1/2 gross	4 3/4 lbs.
11	1/2	23-025	24	11.00	<i>Hurdl</i>	1/2 gross	5 1/4 lbs.
12	9/16	23-025	24	12.00	<i>Hurka</i>	1/2 gross	7 lbs.
8	7/16	23-025	32	8.00	<i>Hurly</i>	1/2 gross	3 1/4 lbs.
9	7/16	23-025	32	9.00	<i>Huop</i>	1/2 gross	3 1/2 lbs.
10	1/2	23-025	32	10.00	<i>Hurra</i>	1/2 gross	4 3/4 lbs.
11	1/2	23-025	32	11.00	<i>Husks</i>	1/2 gross	5 1/4 lbs.
12	9/16	23-025	32	12.00	<i>Hussa</i>	1/2 gross	7 lbs.

ROSE TOOLS, INC.

For general all round work. This type is always furnished unless flexible is specified.

16 and 20 pitch furnished in all sizes if specified.

Prices given for unlisted sizes on application.

List Prices above apply only in the United States and Canada.



UNIVERSAL Hand Hack Saws
Flexible (Tungsten)



Length	Width	Gauge	Teeth	Price per Gross	Code	No. in Box	Weight per Gross
8	7/16	23-025	14	\$ 8.00	<i>Hutch</i>	1/2 gross	3 1/4 lbs.
9	7/16	23-025	14	9.00	<i>Hutto</i>	1/2 gross	3 1/2 lbs.
10	1/2	23-025	14	10.00	<i>Huzza</i>	1/2 gross	4 3/4 lbs.
11	1/2	23-025	14	11.00	<i>Hyaci</i>	1/2 gross	5 1/4 lbs.
12	9/16	23-025	14	12.00	<i>Hyade</i>	1/2 gross	7 lbs.
8	7/16	23-025	18	8.00	<i>Hyali</i>	1/2 gross	3 1/4 lbs.
9	7/16	23-025	18	9.00	<i>Hyber</i>	1/2 gross	3 1/2 lbs.
10	1/2	23-025	18	10.00	<i>Hybod</i>	1/2 gross	4 3/4 lbs.
11	1/2	23-025	18	11.00	<i>Hybri</i>	1/2 gross	5 1/4 lbs.
12	9/16	23-025	18	12.00	<i>Hydag</i>	1/2 gross	7 lbs.
8	7/16	23-025	24	8.00	<i>Hydot</i>	1/2 gross	3 1/4 lbs.
9	7/16	23-025	24	9.00	<i>Hydra</i>	1/2 gross	3 1/2 lbs.
10	1/2	23-025	24	10.00	<i>Hyena</i>	1/2 gross	4 3/4 lbs.
11	1/2	23-025	24	11.00	<i>Hyeto</i>	1/2 gross	5 1/4 lbs.
12	9/16	23-025	24	12.00	<i>Hygel</i>	1/2 gross	7 lbs.
8	7/16	23-025	32	8.00	<i>Hygro</i>	1/2 gross	3 1/4 lbs.
9	7/16	23-025	32	9.00	<i>Hylan</i>	1/2 gross	3 1/2 lbs.
10	1/2	23-025	32	10.00	<i>Hyleg</i>	1/2 gross	4 3/4 lbs.
11	1/2	23-025	32	11.00	<i>Hylic</i>	1/2 gross	5 1/4 lbs.
12	9/16	23-025	32	12.00	<i>Hylot</i>	1/2 gross	7 lbs.

ROSE TOOLS, INC.

Teeth only are hardened. Adapted especially for cutting pipe, tubing and all thin material. 16 and 20 pitch furnished in all sizes if specified.

Prices given for unlisted sizes on application.

The chart on page 109 explains the use of each blade.

List Prices above apply only in the United States and Canada.

MILLERS FALLS COMPANY



UNIVERSAL Power Hack Saws All Hard (Tungsten)



Length	Width	Gauge	Teeth	Price per Gross	Code	No. in Box	Weight per Gross
12	5/8	21-032	14	\$17.88	<i>Hymen</i>	1/2 gross	9 3/4 lbs.
12	5/8	21-032	18	17.88	<i>Hymno</i>	1/2 gross	9 3/4 lbs.
12	3/4	21-032	14	21.36	<i>Hyodo</i>	1/2 gross	11 1/2 lbs.
12	3/4	21-032	18	21.36	<i>Hyoid</i>	1/2 gross	11 1/2 lbs.
14	3/4	21-032	14	24.36	<i>Hyoma</i>	1/2 gross	12 1/2 lbs.
17	3/4	21-032	14	29.04	<i>Hyopl</i>	1/3 gross	17 lbs.
10	3/4	18-049	10	24.72	<i>Hyost</i>	1/3 gross	15 1/4 lbs.
12	3/4	18-049	10	28.92	<i>Hypal</i>	1/3 gross	17 3/4 lbs.
12	3/4	18-049	14	28.92	<i>Hyper</i>	1/3 gross	17 3/4 lbs.
12	1	18-049	10	37.92	<i>Hypne</i>	1/4 gross	24 1/2 lbs.
12	1	18-049	14	37.92	<i>Hypid</i>	1/4 gross	24 1/2 lbs.
14	3/4	18-049	10	33.12	<i>Hypno</i>	1/4 gross	20 lbs.
14	3/4	18-049	14	33.12	<i>Hypki</i>	1/4 gross	20 lbs.
14	1	18-049	10	43.56	<i>Hypob</i>	1/4 gross	28 lbs.
14	1	18-049	14	43.56	<i>Hypco</i>	1/4 gross	28 lbs.
14	1 1/4	18-049	8	53.52	<i>Hypsi</i>	1/12 gross	37 lbs.
14	1 1/4	18-049	10	53.52	<i>Hypur</i>	1/12 gross	37 lbs.
16	1	18-049	10	49.08	<i>Hyrax</i>	1/4 gross	32 lbs.
17	1	18-049	10	51.72	<i>Hyrst</i>	1/4 gross	34 lbs.
17	1	18-049	14	51.72	<i>Hyson</i>	1/4 gross	34 lbs.
18	1	18-049	10	54.36	<i>Hyste</i>	1/4 gross	37 lbs.
20	1	18-049	10	59.52	<i>Hytne</i>	1/4 gross	41 lbs.
21	1	18-049	10	62.04	<i>Hytos</i>	1/4 gross	43 lbs.
24	1	18-049	10	70.32	<i>Hysoz</i>	1/4 gross	47 lbs.
14	1	16-065	8	50.88	<i>Hpast</i>	1/4 gross	32 1/2 lbs.
14	1	16-065	10	50.88	<i>Hpore</i>	1/4 gross	32 1/2 lbs.
16	1	16-065	10	56.88	<i>Hpakf</i>	1/4 gross	42 1/2 lbs.
17	1	16-065	8	59.52	<i>Hpafa</i>	1/4 gross	44 lbs.
17	1	16-065	10	59.52	<i>Hpalk</i>	1/4 gross	44 lbs.
18	1	16-065	8	62.04	<i>Hpamo</i>	1/4 gross	48 lbs.
18	1	16-065	10	62.04	<i>Hpeso</i>	1/4 gross	48 lbs.
18	1 1/2	16-065	6	90.24	<i>Hpetu</i>	1/12 gross	74 lbs.
18	1 1/2	16-065	8	90.24	<i>Hpdam</i>	1/12 gross	74 lbs.
20	1	16-065	10	67.92	<i>Hpuck</i>	1/4 gross	54 lbs.
21	1	16-065	10	70.44	<i>Hpica</i>	1/4 gross	56 lbs.
24	1	16-065	10	79.32	<i>Hpito</i>	1/4 gross	63 lbs.
24	1 1/2	16-065	6	119.04	<i>Hpost</i>	1/12 gross	99 3/4 lbs.
24	1 1/2	16-065	8	119.04	<i>Hpopo</i>	1/12 gross	99 3/4 lbs.

ROSE TOOLS, INC.

14 in. and 17 in. power hack saws are 1/2 in. less to centers than length given. All other saws are true to length stated.

The chart on page 109 explains the use of each blade.

List Prices Above apply only in the United States and Canada.



MILLERS FALLS Metal Cutting Band Saws



Code	Width	Gauge	Teeth Per Inch								List Per Ft.	Price Jointing	Feet Per Lb.
			10	12	14	16	18	20	24	32			
Hbbae	3/16	23-.025	14	16	18	20	24	32	.07	.20	75
Hbba	1/4	23-.025	..	12	14	16	18	20	24	32	.07	.20	60
Hbbca	3/8	23-.025	10	12	14	16	18	20	24	32	.07	.20	35
Hbbdo	1/2	23-.025	10	12	14	16	18	20	24	..	.07	.20	25
Hbbek	5/8	21-.032	10	12	14	16	18	20	24	..	.08	.25	16
Hbbfu	3/4	21-.032	10	12	14	16	18	20	24	..	.09	.30	12
Hbbgi	1	21-.032	10	12	14	16	18	20	24	..	.11	.30	10

NOTE—The code word applies to widths and gauge only. In ordering specify teeth per inch and length of band together with code word.

On fractions of a foot, there will be no charge if it is under 6 inches, but charge for a full foot all fractions 6 inches or more.



ROSE TOOLS, INC.

When ordering give the following information if possible:

- Length of saw if welded.
- Material to be usually cut.
- Thickness of section to be cut.
- Speed of saw in feet per minute.
- Pitch and widths of saw previously used.
- If trouble developed describe scroll or straight cutting.

“Millers Falls” Band Saws are hardened on the teeth only, leaving the back tough. This prevents the band from cracking or breaking while in operation. While the cutting edges of the teeth are hard enough to cut high speed steel, the base is tough enough to withstand the shock of cutting through the thin fins of bronze castings. There are many advantages to be gained by using band saws, such as cutting gates from irregular shaped castings without distorting them, scroll cutting and many operations of slitting on tool work, etc.



HACK SAW FRAMES

SINCE 1880, in the days of the crude wooden frame, the Millers Falls Company has been identified with the manufacture and development of Hack Saw Frames.

Foremost among the modern frames are the Millers Falls "Pistol Grip" and "Easy Grip" types. The distinguishing feature of these frames is the handle, which conforms to the shape of the hand, and permits perfect control of the frame as far as the arm can reach. Further, this handle eliminates hand cramp, and affords a grip so effective that the wobble, which causes blade breakage, is restricted. Detailed specifications of these frames are given on the pages which follow.

None but high grade, ROSE TOOLS, INC. round edge steel is used in Millers Falls frames. The bends are uniformly even so that the blade lines parallel with the back of the frame.

The better grade frames are polished and heavily nickel plated, and the wooden handles, turned out by our own woodworking shop, are characterized by their smooth, highly polished surface.

Another special feature is the patent under cut stud, with blade pins set at an angle to prevent saw falling off if turned at right angles in the frame; also the clamp pins which are set diagonal, rather than parallel, to withstand greater strain.

Two new frames have been added the past year, and improvements made in two of the standard numbers.

There are twenty-five numbers from which to choose, and while many differ in finish and some little refinement, each one is made to the Millers Falls standard, which is set high for quality.

Hack Saw Frame

No. 1027

Improved

This Millers Falls frame has always been popular and these improvements are sure to increase the demand. First, the handle and back reinforcement are now one piece, and adjustment is made by means of one pin instead of two. This adds strength to the back and makes possible an easier and more rapid adjustment. Second, the space between the handle and the frame has been increased providing ample space for even the largest **ROSE TOOLS, INC.**

The handle is moulded in one piece and so designed that the entire frame "hangs" perfectly. Steel rib extending the length of the handle makes it practically unbreakable.

End opposite handle is built close to frame permitting work in very close corners.

Blades strained by thumb nut under handle where it does not interfere with stroke. Blades faceable in four directions.

Polished and nickel plated-frame and special black composition handle. One 10 in. blade furnished with each frame.

Capacity	Depth	Stock	Weight each	Price each
8-12 in.	3¼ in.	3/16 x 11/16 in.	1¾ lbs.	\$1.75

Code—Ichno

Packed one in a box.

Hack Saw Frames

"Pistol Grip"

No. 1011

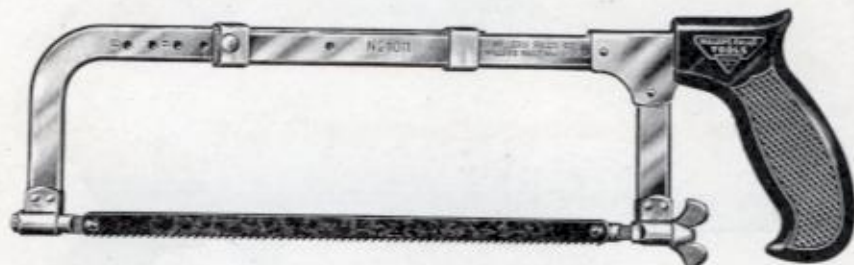

This frame differs from No. 1027 only in depth and the construction of the back. It has the yoke style of adjustment, which is exceptionally strong and rigid. Back is graduated to show different lengths of saws.

Capacity	Depth	Stock	Weight each	Price each
8-12 inch	3½ inch.	3/16 x 11/16 inch.	2 lbs.	\$2.65

Code—*Ichor*

Packed one in a box.

"Easy Grip"

ROSE TOOLS, INC.

No. 12



The handle on this frame affords a grip similar to No. 1027, but differs in construction, it being a part of the adjustable slide on frame. Special black composition handles are screwed on either side.

Blades strained by thumb nut and faceable in four directions. Polished and nickel plated frame. One 10 inch blade furnished with each frame.

Capacity	Depth	Stock	Weight each	Price each
8-12 in.	3½ in.	3/16 x 13/16 in.	2 lbs.	\$3.15

Code—*Ician*

Packed one in a box.



Hack Saw Frames

No. 140

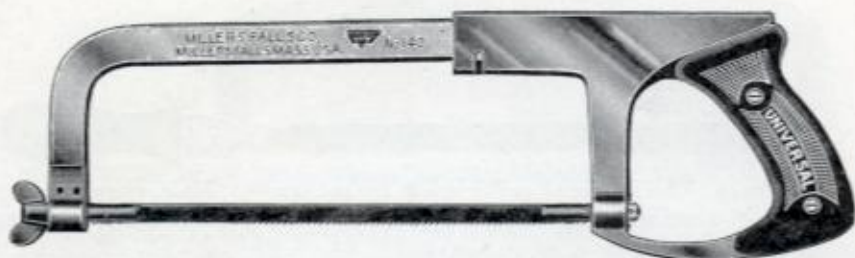

This frame differs from No. 12 in that the handle is brought forward closer to the blade, and the housing for the body is extended $2\frac{1}{4}$ inches forward of the post. This construction insures more rigidity and gives the frame unusual strength.

Capacity	Depth	Stock	Weight each	Price each
8-12 in.	$3\frac{1}{8}$ in.	$3/16 \times 13/16$ in.	2 lbs.	\$3.90

Code—*Icily*

Packed one in a box.

New

No. 1100



An all metal frame of exceptional strength. Back one piece solid steel, will not bend or buckle. Entire frame is sheradized to prevent rust, and for this reason particularly adapted for outdoor use.

"Pistol Grip" handle affords firm, comfortable hold and eliminates hand cramp.

Stop Pin prevents frame from sliding out of handle.

Capacity	Depth	Stock	Weight each	Price each
8-12 in.	$3\frac{1}{8}$ in.	$3/16 \times 13/16$ in.	1 lb. 14 oz.	\$2.40

Code—*Icery*

Packed one in a box.



Hack Saw Frames

Nos. 10 and 11

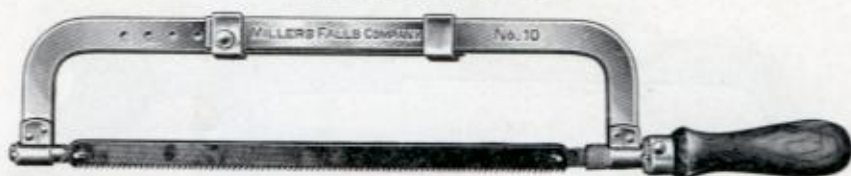

Unusually rigid back. Adjustment easily made by set screw. End opposite handle built close permitting operation in close corners. Check nut keeps blade from falling off if turned at right angle.

Blades strained by handle and faceable in four directions. Scale for different lengths on back of frame.

Polished and nickel plated. Cocobolo handle. One 10 inch blade with each frame.

	Capacity	Depth	Stock	Weight each	Price each
No. 10	8-12 in.	2 3/8 in.	3/16 x 11/16 in.	1 lb., 5 oz.	\$2.25
No. 11	8-12 in.	3 1/2 in.	3/16 x 11/16 in.	1 1/2 lbs.	2.40

Code No. 10—*Icing*

Code No. 11—*Icity*

Packed one in a box.

No. 6



A compact, stiff frame with solid back, adjustable by means of sliding end post. Otherwise, construction and finish same as No. 10.

One 12 inch blade furnished with each frame.

Capacity	Depth	Stock	Weight each	Price each
6-12 in.	2 3/4 in.	3/16 x 13/16 in.	1 lb., 7 oz.	\$2.25

Code—*Icono*

Packed one in a box.

No. 9



A light, yet strong frame. Adjustable by means of sheath back. Blades strained by turning handle and can be faced in four directions.

Knurled check nut holds blade in place.

Polished and nickel plated. Cocobolo handle. One 10 inch blade furnished with each frame.

Capacity	Depth	Stock	Weight each	Price each
8-12 in.	2 3/4 in.	3/16 x 9/16 in.	1 lb., 3 oz.	\$2.00

Code—*Icosa*

Packed one in a box.



Hack Saw Frames

No. 27



Same back construction as No. 9 but of heavier stock. Blades strained by thumb nut and can be faced in four directions. Polished and nickel plated steel stock. Stained hardwood handle. One 10 inch blade furnished with each frame.

Capacity	Depth	Stock	Weight each	Price each
8-12 in.	3 1/4 in.	3/16 x 11/16 in.	1 lb., 6 oz.	\$1.70

Code—Ideal

Packed one in a box.

No. 26



A light, stiff frame with sheath back. In this type one end of the frame is solid in back, and adjustment for blades made with opposite end.

Blades strained by thumb nut and can be faced in four directions. Polished and nickel plated steel. Stained hardwood handle. One 10 inch blade furnished with each frame.

Capacity	Depth	Stock	Weight each	Price each
8-12 in.	3 1/8 in.	3/16 x 11/16 in.	1 lb., 6 oz.	\$1.30

ROSE TOOLS, INC.

Code—Idiot

Packed one in a box.

No. 78



A low priced extensible frame differing from No. 26 only in the size of steel stock and the fact that the square stud can be swivelled without removing stud from the frame.

Capacity	Depth	Stock	Weight each	Price each
8-12 in.	2 1/2 in.	5/32 x 11/16 in.	1 lb.	\$1.10

Code—Idler

Packed one in a box.



Hack Saw Frames

Nos. 15 and 515

Improved

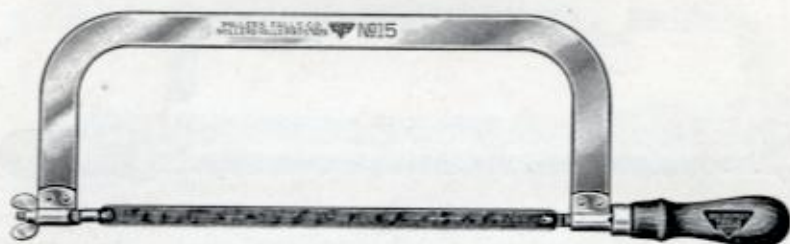

These frames are made extra heavy for work on rails, girders, etc. Blades are strained by thumb nut and are faceable in four directions. Knurled check nut holds blade in place.

No. 15 is polished and nickel plated, No. 515 is enameled black. Both have stained hardwood handle. One 12 inch blade furnished with each frame.

	Capacity	Depth	Stock	Weight each	Price each
No. 15	12 in.	5 $\frac{1}{4}$ in.	1 x $\frac{1}{4}$ in.	2 lbs., 7 oz.	\$2.90
No. 515	12 in.	5 $\frac{1}{4}$ in.	1 x $\frac{1}{4}$ in.	2 lbs., 7 oz.	2.25

Code No. 15—*Idyll*

Code No. 515—*Iliac*

Packed one in a box.

Nos. 14, 14 $\frac{1}{2}$ and 24

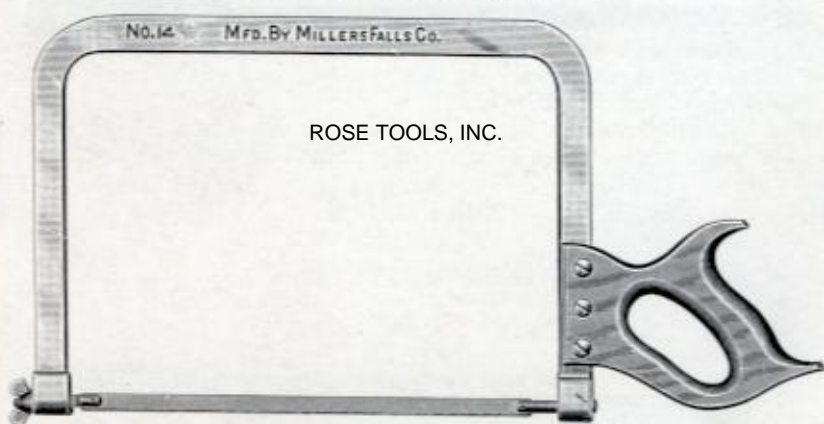

Deep, heavy frames for sawing steel rails, girders and other large work. Handle of beech wood, shaped to give firm, comfortable grip.

Nos. 14 and 14 $\frac{1}{2}$ polished and nickel plated. No. 24 enameled black. One 12 in. blade furnished with each frame.

	Capacity	Depth	Stock	Weight each	Price each
No. 14	12 in.	10 $\frac{1}{4}$ in.	1 x $\frac{1}{4}$ in.	3 lbs., 10 oz.	\$4.15
No. 14 $\frac{1}{2}$	12 in.	7 $\frac{1}{4}$ in.	1 x $\frac{1}{4}$ in.	3 lbs.	3.70
No. 24	12 in.	10 $\frac{1}{4}$ in.	1 x $\frac{1}{4}$ in.	3 lbs., 10 oz.	2.70

Code No. 14—*Ileum*

Code No. 14 $\frac{1}{2}$ —*Ilkon*

Code No. 24—*Ileck*

Packed one in a box.



Hack Saw Frames

No. 1200

New

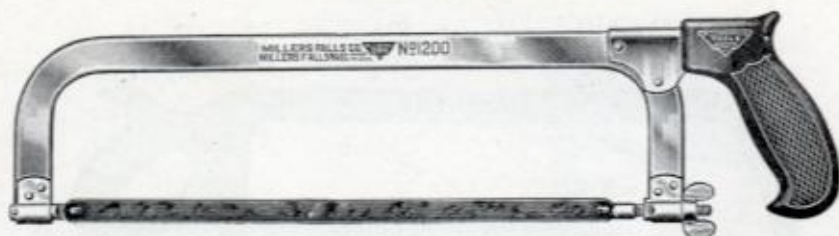

Here is a new addition to our line of pistol grip hack saw frames. It is a solid back type with capacity of 12 inch blades only. An especially strong frame, built to stand hard usage. Handle same as No. 1027. Blades strained by thumb nut and faceable in four directions. One 12 in. blade furnished with each frame.

Capacity	Depth	Stock	Weight each	Price each
12 in.	3½ in.	3/16 x 13/16 in.	1½ lbs.	\$1.75
Code—Image				
Packed one in a box.				

Improved

Nos. 124-126



Low price solid back steel frames. Blades strained by handle and faceable in four directions. Nickel plated. Stained hardwood handle. One blade furnished with each frame.

	Capacity	Depth	Stock	Weight each	Price each	Code
No. 124	8 in.	3¼ in.	3/16 x 11/16 in.	14 oz.	\$.95	Imbay
No. 125	10 in.	3⅜ in.	3/16 x 11/16 in.	1 lb.	1.10	Imbed
No. 126	12 in.	3⅝ in.	3/16 x 11/16 in.	1 lb., 3 oz.	1.20	Imbue
Packed one in a box.						

Nos. 4A, 4B, 4C and 4D



Cast iron frames, black enameled. Stained hardwood handle. Blades strained by thumb nut and faceable in four directions. No blade furnished.

	Capacity	Depth	Weight each	Price each	Code
No. 4A	8 in.	2¼ in.	1 lb.	\$.55	Imide
No. 4B	9 in.	2¼ in.	1⅛ lbs.	.60	Imply
No. 4C	10 in.	2¼ in.	1¼ lbs.	.65	Impor
No. 4D	12 in.	2¼ in.	1⅝ lbs.	.70	Imane
Packed six in a box.					

Butcher Saw Frame No. 2



A strong, well made frame of good proportions and correct balance. Frame is of special crucible steel, polished. Handle is of beech, edges are polished. Offset stud brings saw to center of frame. One blade furnished with each frame.

Capacity	18 in.	20 in.	22 in.	24 in.	26 in.
Weight each	2¼ lbs.	2½ lbs.	2¾ lbs.	3¼ lbs.	3½ lbs.
Price each	\$2.90	3.00	3.35	3.45	3.50
Code	<i>Inarm</i>	<i>Incog</i>	<i>Incur</i>	<i>Indam</i>	<i>Indic</i>

Packed four in a box.

"Economy" Butcher Saw Blades



None but the finest quality steel is used in the making of these blades. Utmost care is given to the hardening and tempering. Because of the thoroughness with which they are made, they will outcut an ordinary blade three to one.

Unless otherwise specified saws furnished 11/16 wide with 9½ teeth to the inch.

Furnished to order ½ inch wide with 14 teeth to the inch.

Length	18 in.	20 in.	22 in.	24 in.	26 in.
Weight (½ gross) 11/16 in.	5½ lbs.	6 lbs.	6½ lbs.	7 lbs.	7½ lbs.
Weight (½ gross) ½ in.	4 lbs.	4½ lbs.	5 lbs.	5½ lbs.	
Price per dozen	\$2.05	2.20	2.30	2.45	2.55
Code	<i>Indif</i>	<i>Indue</i>	<i>Inial</i>	<i>Inker</i>	<i>Inkle</i>

Packed one-half gross in a box.

Kitchen Saw

No. 347



A meat saw made especially for home use. Frame is of flat steel, polished. Handle is of beech wood and is securely fastened to frame. Blade strained by thumb nut.

Depth under back $4\frac{1}{2}$ inches. Capacity 14 inch blades.

Weight each, 14 oz.

Price each, with one blade, \$1.05

Code—Inlaw

Price of blades, per dozen, \$1.75

Packed six in a box.

Turning Saw Frame

No. 357

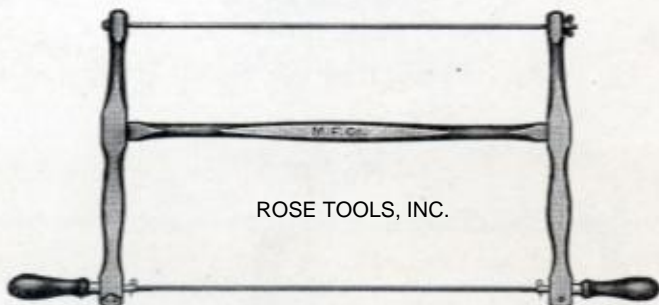

ROSE TOOLS, INC.

This frame is made of birch wood, which is particularly adapted for web saws because it is light, yet strong. Blades held by steel pins, strained by thumb nut. Friction on handles regulated by screws. Steel tension rod. Handles stained. Depth $7\frac{1}{4}$ inches. One blade furnished with each frame.

Capacity	14 in.	18 in.	24 in.
Weight each	1 lb., 6 oz.	1 lb., 10 oz.	1 lb., 14 oz.
Price each	\$1.70	1.80	2.00
Code	Inlay	Inlet	Innew

Packed one in a box.

Turning Saw Blades

Length	14 in.	18 in.	24 in.
Width	$\frac{3}{16}$ in.	$\frac{3}{16}$ in.	$\frac{3}{16}$ in.
Weight per dozen	5 oz.	6 oz.	9 oz.
Price per dozen	\$3.55	4.45	6.20
Code	Inner	Innox	Innof

Coping Saws

No. 42

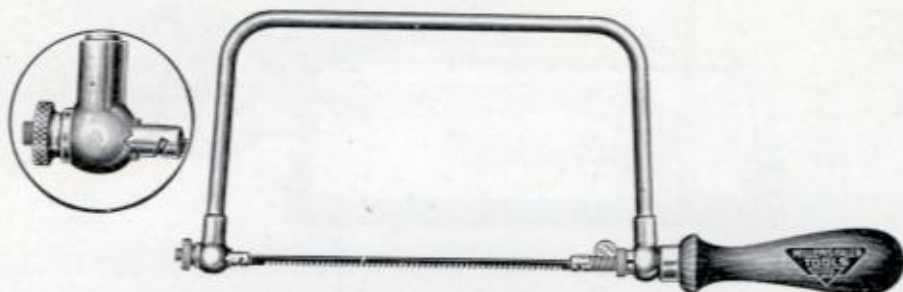

This is our most improved frame and is unsurpassed for ease of operation and convenience in sawing under all conditions.

Ball bearings located under the outer head permit free action of the blade and insure its constant alignment. The frame can be set to swing free regardless of the direction the blade takes in sawing. A circle can be cut out without stopping to adjust it.

*By means of locking devices at both ends of the blade, it can be locked rigid in the frame facing in any one of four directions. Holds both Nos. 60 and 65 blades. Three No. 60 blades with each frame.

Frame of heavy steel wire, polished and nickel plated. Stained hardwood handle.

Depth $4\frac{1}{8}$ inches.

Weight each, 7 oz.

Price each, \$1.55

Code—Irade

Packed three in a box.

ROSE TOOLS, INC.

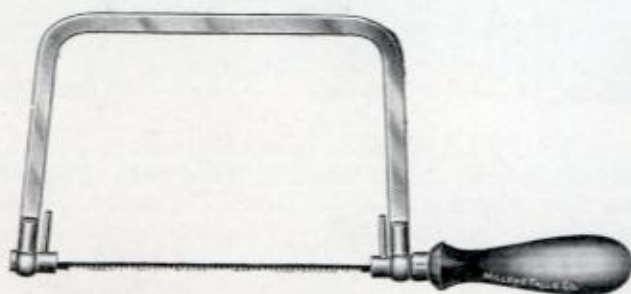

This is a rigid, durable frame, made of stiff, flat spring steel. Blade is controlled by pins in studs at either end, making it unnecessary to remove blade from frame when it is desired to change direction of cut. Blades are strained by turning handle, and can be locked at any angle by turning handle against frame clamp. Holds both Nos. 60 and 65 blades. One No. 65 blade furnished with each frame.

Nickeled metal parts. Stained hardwood handle.

Depth $4\frac{3}{4}$ inches.

Weight each, 6 oz.

Price each, \$.90

Code—Irian

Packed six in a box.



Coping Saws

No. 40

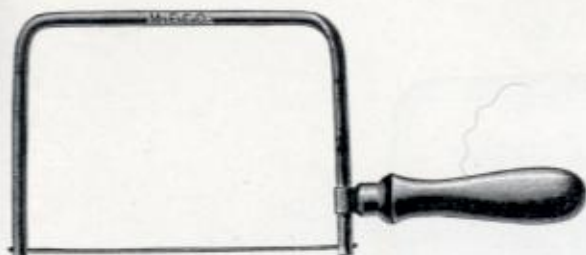

Depth $3\frac{3}{4}$ inches.

Weight each, 4 oz.

Price each, \$.55

Code—*Irida*

Packed twelve in a box.

This frame is smaller and less expensive than Nos. 42 and 43.

Frame is of steel wire, nicked. Handle is stained hardwood and is securely clamped to the frame. Holds either No. 50 or 60 blades. One dozen No. 50 blades furnished with each frame.

No. 44

This is a low priced, yet serviceable frame. Made entirely of stiff wire stock, $\frac{1}{4}$ inch in diameter, and nicked overall. Blades are faceable in four directions. Holds either No. 50 or 60 blades. One dozen No. 50 blades furnished with each frame.

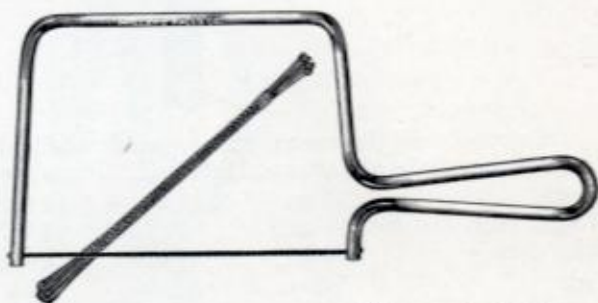

Depth 4 inches.

Weight each, 5 oz.

Price each, \$.35

Code—*Irish*

Packed six in a box.

Coping Saw Blades

No. 50

ROSE TOOLS, INC.

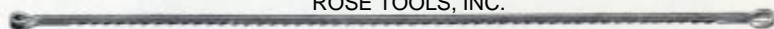

Loop, or turned ends, pattern. For use with Nos. 40 and 44 frames.

Dimensions 6 x $\frac{1}{16}$ inches.

Weight per gross, 6 oz.

Price per gross, \$1.55

Code—*Irous*

Packed one dozen in an envelope, also in boxes of five gross, each gross separately wired.

Nos. 60 and 65

(Pin Pattern)



These blades cut faster and straighter, and will outwear the finer toothed blades. Made of spring tempered steel. Pins solidly held. No. 60 for use with frames Nos. 40, 42, 43 and 44. No. 65 for use with frames Nos. 42 and 43.

Dimensions.....	No. 60 6 x $\frac{3}{32}$ in.	No. 65 $6\frac{1}{2}$ x $\frac{3}{32}$ in.
Weight per gross.....	9 oz.	11 oz.
Price per gross.....	\$3.10	\$3.10
Code	<i>Ischi</i>	<i>Isiac</i>

Packed one dozen in an envelope.

Fret Saw Frame No. 367

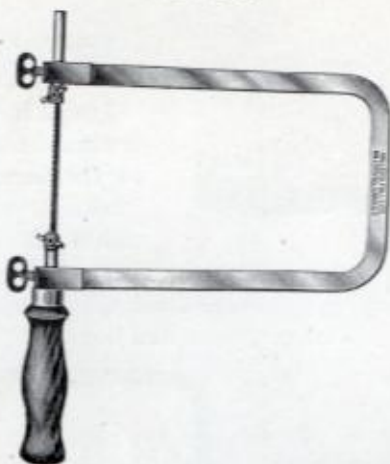

A strong, well balanced frame, made of high grade spring steel. Frame is polished and nicked; handle is of hardwood, stained. Parts are interchangeable.

Depth	10 in.	12 in.	14 in.	16 in.
Weight each	14 oz.	1 lb.	1 lb., 2 oz.	1 lb., 3 oz.
Price each	\$1.95	2.00	2.05	2.10
Code	<i>Islam</i>	<i>Islet</i>	<i>Itala</i>	<i>Itchy</i>

Packed one in a box.

Fret Saw Sets

No. 2

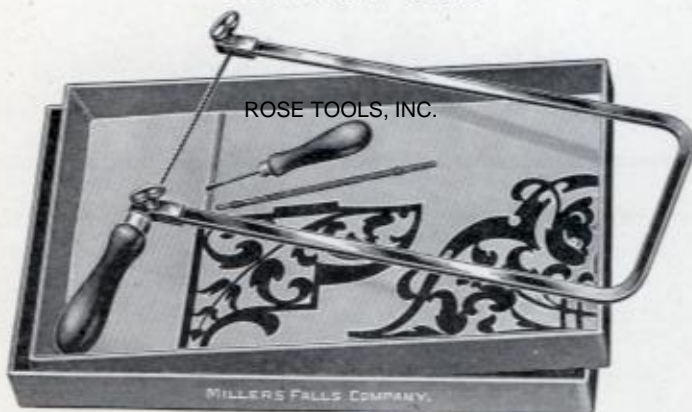

An excellent set for amateurs. The frame is of high grade spring steel, with enameled handle, and patent clamps, which hold the blade securely. Frame has depth of 12 inches, width of 5 inches, and is highly polished and nickel plated. Other articles include twelve blades, one awl, one sheet of impression paper and three sheets of designs.

Weight each, 17 oz.

Code—*Itive*

Price each, \$1.50

Packed one set in a box.

No. 1

The frame in this set is white nicked and has japanned iron handle. Otherwise the set is identical with No. 2.

Weight each, 14 oz.

Code—*Iulus*

Price each, \$1.10

Packed one set in a box.



Millers Falls Fret Saw

No. 387

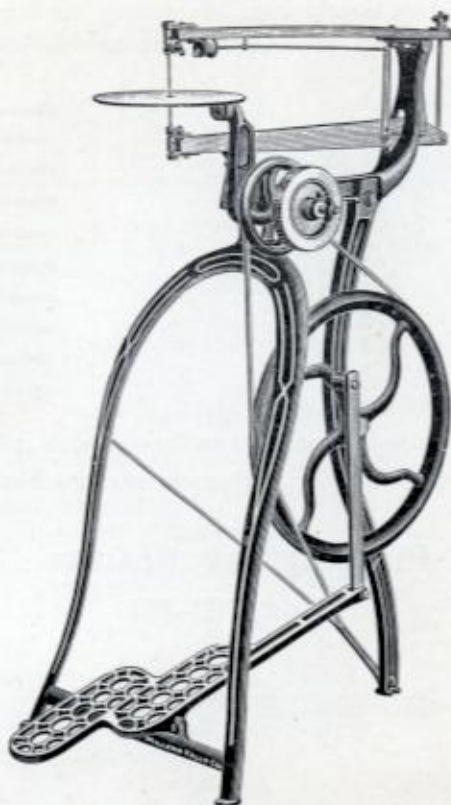

A fret saw machine is easier to use than a hand saw, and can be operated at greater speed. These features are of particular advantage if one is doing this work for profit.

The distinguishing feature of this machine is the design of the adjustable lever saw clamps, which minimizes blade breakage.

Equipped with drilling attachment and automatic dust blower.

All screws and bolts are carefully fitted, so that each part of the machine is secure and strong.

There are two balance wheels, one each of iron and emery, adding steadiness to the machine.

The arms swing on pivots in their supporting casting which gives free action and are adjustable so that they can be kept parallel.

It can be equipped for use with small $\frac{1}{4}$ H.P. motor if desired. One-quarter inch belt should be run from motor on to small pulley.

Twelve saw blades, one wrench, three sheets of designs, impression paper and three drill points are furnished with each machine.

Specifications

Frame—cast iron. Arbors—steel. Arm and pitman—selected ash wood.

Japanned tilting table. Depth of arms 18 inches.

Height overall 37 inches. Capacity, up to $\frac{3}{8}$ inch wood.

Weight boxed 60 lbs., net 40 lbs.

Price each, \$17.75

Code—*Ixora*

Knocked down and packed one in a wooden case.



“Economy” Fret Saw Blades

Successful fret sawing depends largely upon the cutting qualities of the blades. “Economy” blades are true to their name—for they have no equal for durability. Cut fast, smooth, and are of uniform high quality.

Length overall 5 inches.

	Nos.	Price per gross.
	000	\$1.60
	00	1.60
	0	1.60
	1-3	1.70
	4-6	1.80
	7-9	1.90
	10-12	2.00
Ass't.	0-6	1.70
	1-6	1.70



Code—Ivory

Packed one gross each size in a package and ten gross in a box.

Also put up ten gross in a box, each gross assorted Nos. 1 to 6.

Piercing Saw Frames

Nos. 380-382



ROSE TOOLS, INC.

Designed especially for silversmiths and workers in arts and crafts. It is a well balanced frame and handles easily. The handle conforms to the hand and the end rests comfortably against the body, when adjusting blade into the frame.

Specifications

Frame—stiff spring steel, burnished.

Clamps—steel. Checked and hardened.

Handle—hardwood, stained and polished.

Nos.	380	381	382
Depth	4 in.	5 in.	6 in.
Weight each	7 oz.	8 oz.	9 oz.
Price each	\$1.60	1.75	1.90
Code	Jager	Jakes	Jakie

Packed four in a box.



Jeweler Saw Frames

No. 377

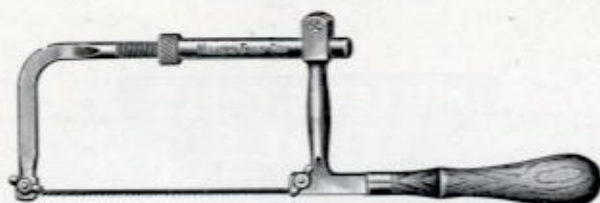

This frame is of better construction than the ordinary tool of this kind.

It is adjustable from 4 to 6 inches by means of a knurled nut, which locks securely against the solid portion of the back.

The upright post is firmly fastened to back by a set screw. Blades are held by thumb screws at either end.

Specifications

Frame—forged spring steel, nickered.

Clamps—steel.

Handle—hardwood, stained.

Depth $2\frac{1}{4}$ inches.

Weight each, 4 oz.

Price each, \$2.70

Code—*Jabot*

Packed three in a box.

Nos. 378-379

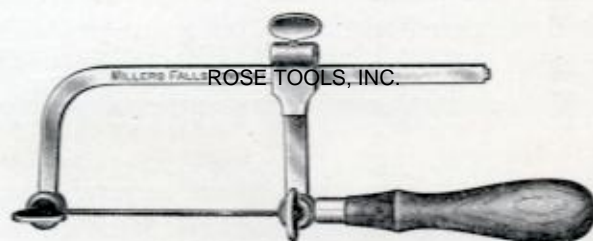

These are light, well balanced frames, less expensive than No. 377. Adjustable from 4 to 6 inches, by means of thumb screw. Blades held securely by thumb screw at either end.

Specifications

Frame—forged spring steel, nickered.

Clamps—steel. Checked and hardened.

Handle—cocobolo, highly polished.

Nos.....	378	379
Depth.....	2 in.	3 in.
Weight each.....	3 oz.	4 oz.
Price each.....	\$1.35	1.45
Code	<i>Jacky</i>	<i>Jacob</i>

Packed three in a box.



GLASS CUTTERS

Millers Falls engineers have devoted much time the past year to the study of Glass Cutters and glass cutting problems. As a result of this intensive study, we have produced a glass cutter wheel which we believe to be as nearly perfect as a steel wheel can be.

These wheels are made of the choicest tool steel, carefully hardened and tempered and individually ground and honed to the proper bevel. Each separate wheel is tested twice before being set. This exacting care insures uniformly perfect cutting wheels.

In addition to this improved wheel, several changes have been made in the design of the heads and handles, notably our most popular numbers—No. 7 and No. 300.

We offer our Glass Cutter line to the trade with full confidence that it will meet the most exacting requirements demanded of this type of tool.

Each cutter is packed in an individual carton which insures it reaching the user in perfect condition.



Glass Cutters (Multiple Wheel)

No. 300

Improved



This multiple wheel cutter is a great convenience because as soon as a wheel becomes dull, a turn of a screw loosens the set screw and a sharp wheel is instantly in place.

The revolving turret contains six Millers Falls "Perfect Cutting" wheels, numbered as indicated in illustration. Turret is flush with frame. Cutter arbor is integral with turret—wheels protected from injury. This feature is patented.

Improved easy grip handle, hardwood, enameled.

Steel cutter head and frame, polished and nickel plated.

Weight per dozen, $\frac{3}{4}$ lbs.

Price per dozen, \$4.35

Code—Kafir

Packed one in a box, and one dozen in a large box.

No. 100



This cutter works on the same principle as No. 300, but the head is of different design.

Revolving turret contains seven Millers Falls "Perfect Cutting" wheels. Turret is loosened and clamped fast by a thumb screw. This set can be operated with a screw driver if desired. Axles in turret are controlled by a device to prevent their falling out of place while inserting new wheels.

Handle, cocobolo, polished. Steel turret and frame, polished.

Weight per dozen, 15 oz.

Price per dozen, \$9.60

Code—Kafita

Packed one in a box, and one dozen in a large box.

No. 30



A multiple wheel cutter containing four Millers Falls "Perfect Cutting" wheels in a revolving turret head. Head is loosened and clamped fast by means of a thumb screw. Four milled notches act as breakers.

Hardwood handle, highly polished. Steel cutter head is polished.

Weight per dozen, $\frac{3}{4}$ lb.

Price per dozen, \$7.65

Code—Kalam

Packed one in a box, and one dozen in a large box.



Glass Cutters

(Single Wheel)

No. 7

Improved



A low priced single wheel cutter. Improved easy grip handle.

Handle is of iron, enameled red. Cutter head is polished.

Weight per dozen, $\frac{3}{4}$ lb.

Price per dozen, \$1.95

Code—Kabob

Packed one in a box, and one dozen in a large box.

No. 5



This number has a heavy ball-shaped head for lightly tapping the glass after cut has been made. It will be found useful when cutting double thick or plate glass.

Otherwise same as No. 7.

Weight per dozen, 15 oz.

Price per dozen, \$1.95

Code—Kafal

Packed one in a box, and one dozen in a large box.

No. 1



The iron handle on this cutter is heavier and of different design than Nos. 7 and 5. The finish however, is the same.

Weight per dozen, 17 oz.

Price per dozen, \$2.45

Code—Kahau

Packed one in a box, and one dozen in a large box.

Wheels will cut better and last longer if dipped frequently in kerosene. Keeping entire cutter head immersed when not in use is advisable.



Circular Glass Cutter

No. 301

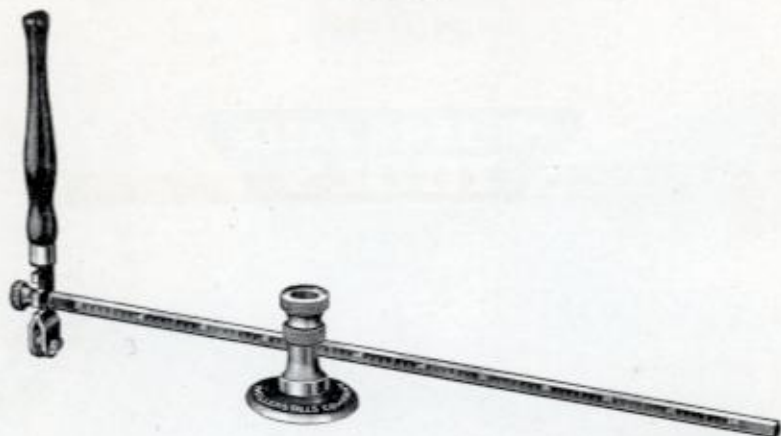

This tool serves a double purpose. With the cutter attached it will cut circles from 2 to 24 inches in diameter, accurately and quickly.

Unscrewing the knurled end nut, releases the cutter which can be used as an ordinary glass cutter.

The cutter is our regular No. 300 with revolving turret head, containing six Millers Falls "Perfect Cutting" wheels, each wheel numbered.

Sliding bar is of hexagonal steel, and is graduated by sixteenths of an inch. The standard has a cork disk inserted to prevent slipping.

Handle—hardwood, enameled mahogany finish.

Metal parts polished and nickel plated.

Weight each $\frac{1}{2}$ lb.

Code—Kalif

Price each, \$1.25

Packed one in a box.

ROSE TOOLS, INC.

Gauge Glass Cutter

No. 202



This tool is made for cutting glass tubes and has capacity up to eight inches long. Rod is easily adjustable by thumb nut. Removable axle on cutting head. Equipped with one Millers Falls "Perfect Cutting" wheel. Magazine in end of handle contains five extra wheels.

Rod is of steel, polished. Dimensions $9 \times \frac{3}{16}$ in. Handle is of hardwood, stained and polished.

Weight each $1\frac{1}{2}$ lbs.

Code—Kalki

Price each, \$.90

Packed six in a box.

Hold the cutter between the first and second fingers, draw the wheel entirely across the glass, and break by giving a slight bend while holding the pane tightly between the thumb and first finger of each hand.



MITRE BOXES

Accuracy and durability are the chief requisites of a mitre box. Other features are of secondary importance.

Since first manufactured, these qualities in Millers Falls Langdon Mitre Boxes, have been unquestioned.

Foremost among the styles we make is the Langdon Acme. This box represents the ~~ROSE TOOLS, INC.~~ of mitre box efficiency.

Its distinguishing features are: the extra long saw guide to give stability; automatic catch holding these guides at their highest points; releasing them instantly when desired; guides to support the work against back or for use when angles of more than 45 degrees are desired, and which are easily slid out of the way when not in use; take up to provide for wear on the screw. These and other refinements have made it the favorite mitre box with carpenters everywhere.

A number of different styles are shown in the pages following, each having its particular uses and advantages, and each one made with characteristic Millers Falls thoroughness, both in the selection of material and to every detail of manufacture.



Mitre Boxes (Langdon Acme) Nos. 68-75

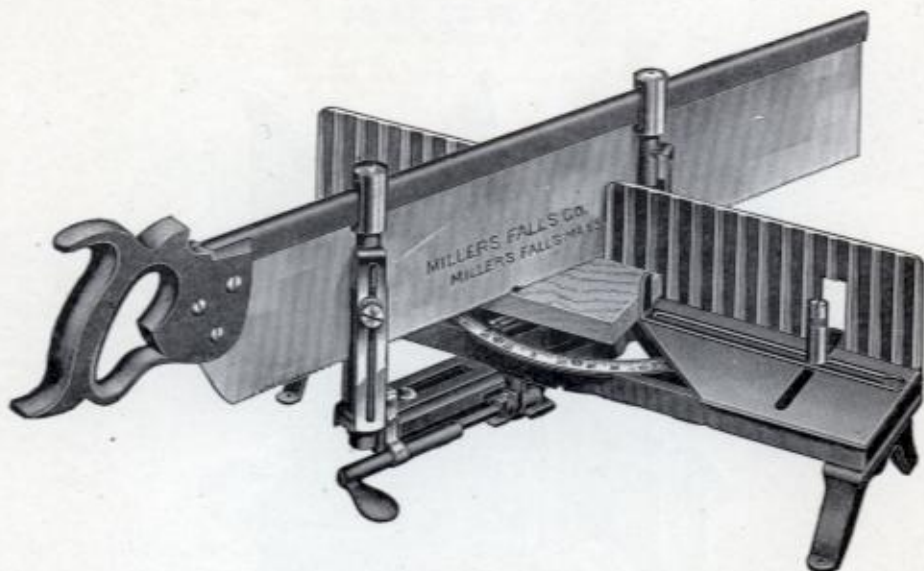

This is our most improved type of box, and has, in addition to the refinements described on the preceding page, the following features:

Thumb lever at front of box by means of which saw supports can be swung freely and locked at either a positive or any intermediate angle.

Graduated arc and index plate to show what degrees to set the saw for certain cuts.

Notched bed plate determines the positive angles most used.

Extension lever for quick acting adjustment on all except size one boxes.

Length and depth gauges.

Steel bottom boards roughened to prevent work from slipping.

Made of iron and steel castings. Main castings are enameled black.

Steel bed plates enameled red. Bright parts nickel plated.

ROSE TOOLS, INC.

Nos.	Size	Dimensions of Saw Inches.	Capacity at Right Angles Inches.	Capacity at Mitre. Inches.	Weight Boxed. Pounds.	Weight Net. Pounds.	Code	Price
68	1	22 x 4	7½	5	34	23	<i>Labor</i>	\$21.15
69	1	24 x 4	7½	5	35	23½	<i>Labra</i>	22.00
70	1	26 x 4	7½	5	36	24	<i>Lacic</i>	22.90
71	2	22 x 4	10¼	7	34	23	<i>Lacer</i>	22.90
72	2	24 x 4	10¼	7	35	23½	<i>Ladde</i>	23.75
73	2	26 x 4	10¼	7	36	24	<i>Ladim</i>	24.10
74	2½	28 x 5	10¼	7	37	25	<i>Ladle</i>	27.25
75	2½	30 x 5	10¼	7	38	25½	<i>Lager</i>	28.95

(Above saws are all 11 point.)

BOXES WITHOUT SAWS.

1068	1	7½	5	26	20	<i>Lagry</i>	\$16.65
1071	2	10¼	7	26	21	<i>Laird</i>	18.45
1074	2½	10¼	7	27	22	<i>Laily</i>	20.70

Boxes are guaranteed accurate only when equipped with saws fitted by ourselves.



Mitre Boxes

(New Langdon Improved)

Nos. 29-32-33-34

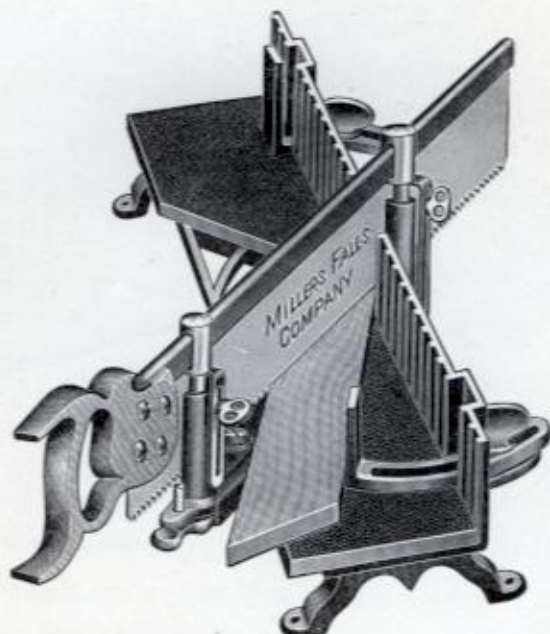

While these boxes have not all the features of the Langdon Acme, they have every feature essential to a complete mitre box.

Saw supports can be quickly swung and clamped at any angle from 45° to 90° either to the right or to the left. Angles most in use are determined by notches cut into baseplate.

Circular arms permit cutting any angle from 45° to 90°—and also at any angle from 15° to 90°, on 2½ inch stock. Have depth gauge, and gib to support work.

Nos.	Size	Dimensions of Saw Inches	Capacity at Right Angles Inches	Capacity at Mitre Inches	Weight Boxed Pounds	Weight Net Pounds	Code	Price
29	1	24 x 4	6¾	4½	28	18	Lakin	\$18.50
32	2	24 x 4	9¾	6¾	29½	20	Lakke	20.25
33	2	26 x 4	9¾	6¾	30	20½	Lamel	21.25
34	2½	28 x 5	9¾	6¾	34	22	Lamia	23.75

(Above saws are all 11 points.)

BOXES WITHOUT SAWS

1029	1		6¾	4½	21	13	Lampi	\$13.25
1032	2		9¾	6¾	22½	14½	Lance	14.25
1034	2½		9¾	6¾	26½	18½	Lande	16.80



Mitre Boxes

(New Langdon)

Nos. 17-23-25

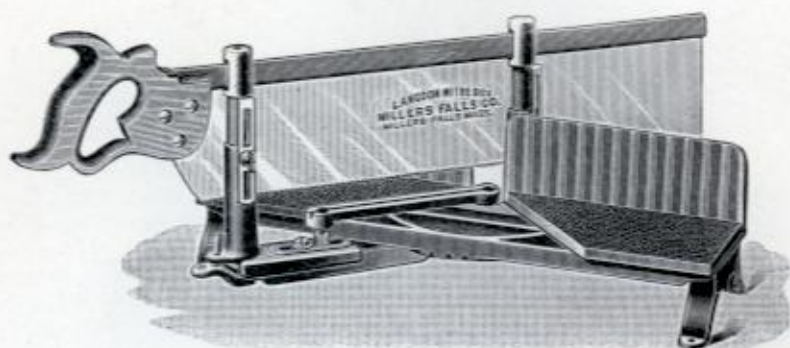

These boxes are identical with Nos. 29, 32, 33 and 34 except that they are without the circular arms. Their capacity, therefore is from 45° to 90° only.

Nos.	Size	Dimensions of Saw Inches	Capacity at Right Angles Inches	Capacity at Mitre Inches	Weight Boxed Pounds	Weight Net. Pounds	Code	Price
17	1	18 x 4	6 $\frac{3}{4}$	4 $\frac{1}{2}$	24	14	Lapis	\$14.15
23	2	24 x 4	9 $\frac{3}{8}$	6 $\frac{3}{8}$	27 $\frac{1}{2}$	16	Lapse	18.50
25	2 $\frac{1}{2}$	28 x 5	9 $\frac{3}{8}$	6 $\frac{3}{8}$	30 $\frac{1}{2}$	18	Larch	22.00

ROSE TOOLS, INC.

(Above saws are all 11 point.)

BOXES WITHOUT SAWS.

1017	1		6 $\frac{3}{4}$	4 $\frac{1}{2}$	20 $\frac{1}{2}$	12 $\frac{1}{2}$	Larix	\$11.40
1023	2		9 $\frac{3}{8}$	6 $\frac{3}{8}$	22	14	Larne	12.50
1025	2 $\frac{1}{2}$		9 $\frac{3}{8}$	6 $\frac{3}{8}$	26	18	Larya	15.10

Important

The length of a mitre box saw, commonly called a back saw, is determined by the length of the blade, not the length of the cutting edge. Saws furnished with our boxes are all clipped off rounding at the butt to prevent pricking the thumb when swinging the lever from side to side. This cuts off about 1 $\frac{1}{2}$ inches of the cutting edge of the saw, but is really no loss, as the part cut off would come directly under the handle, and would be of no practical use.

These saws, therefore, seem to measure nearly two inches shorter than they really are. In measuring your saw be careful to measure the entire length of blade.

Mitre Boxes (Langdon) Nos. 15½ and 16½

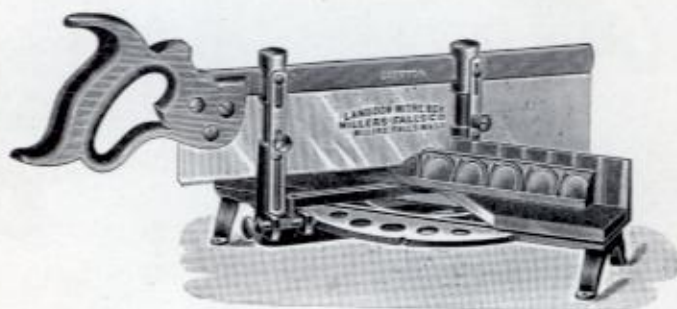

ROSE TOOLS, INC.

These are small boxes, easily portable, and are especially adapted to cutting mouldings and other light work.

Saw supports can be quickly swung and clamped at any angle, from 45° to 90° either to the right or to the left. Notches are cut in baseplate at angles most used.

No. 16½ box does not have the slotted elevators shown in illustration.

Nos.....	15½	16½
Size.....	C	B
Dimensions of saw.....	16 x 2½ in.	16 x 2 in.
Capacity at right angles.....	4½ in.	4½ in.
Capacity at mitre.....	3 in.	3 in.
Weight, boxed.....	14 lbs.	11 lbs.
Weight, net.....	8 lbs.	7 lbs.
Price.....	\$12.50	11.00
Code.....	Lavic	Lawny

(Above saws are 12 points.)

Prices of boxes without saws: size C, \$7.50; size B, \$6.80.

Mitre Boxes

No. 41

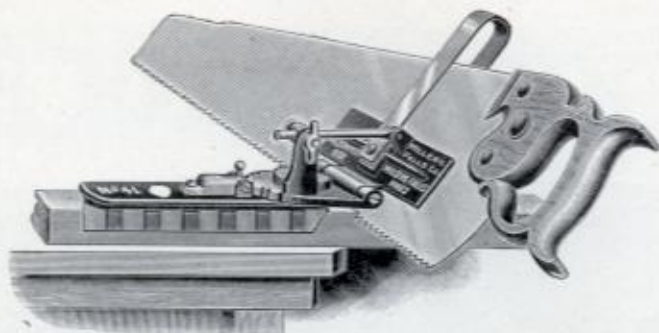

This is a small, light tool designed for use in places where it is impracticable to use the larger boxes. It is especially handy for sawing moulding, cornices, etc., when working at the top of a ladder.

The saw clamp is attached to the rest of the tool by a hinge which permits the saw to be tilted for cutting a wide range of bevels. This is of particular use in jointing floors.

The bedplate has a double shelf or rest, permitting the cut to be made at an angle either to the right or to the left.

Notches are cut into the shifting arc to determine the angles ordinarily used.

The saw guide holds securely either back or panel saws.

The tool is made of iron and steel, with bright parts nicked and other parts japanned black.

Weight each, $2\frac{1}{2}$ lbs.

Price each, \$5.50

Code—Leach

Packed two in a box.

No. 40

ROSE TOOLS, INC.

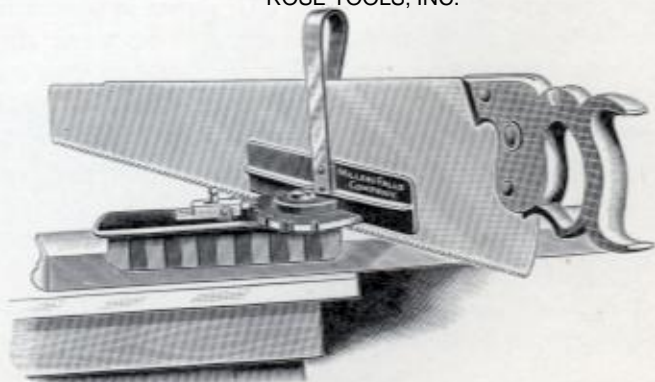

In this tool the saw clamp is solid to the rest of the tool, instead of hinged, so the saw cannot be tilted to cut a bevel. Otherwise it is identical with No. 41.

Weight each, $2\frac{1}{4}$ lbs.

Price each, \$4.50

Code—Leafy

Packed one in a box.

Mitre Planer

No. 3½

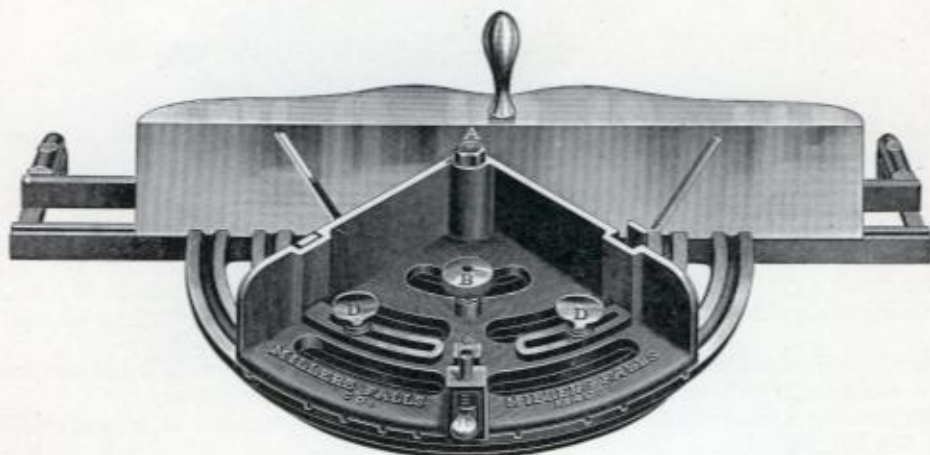

A machine used extensively for picture framing.

The principal parts are: a semicircular bedplate with a runway at the rear; a plane sliding upon this runway; and a quadrant swinging to right to left upon the bedplate with a point A, shown in illustration, as a pivot.

The quadrant is clamped by catch C, shown in illustration, in notches in the bedplate at the angles most in use and at intermediate points by thumb screw B, also shown in illustration. When set in the middle of the bedplate, the side elevations of the quadrant form a perfect mitre for four-sided work.

ROSE TOOLS, INC.

Has adjustable arms, clamped with thumb screw DD, shown in illustration, of especial use in enabling one to finish the ends and angles on curved work with exactness. In preparing pieces for circular or oval work, frames pulleys, emery wheels, circular patterns, etc., it is necessary to plane the ends of the various segments at varying angles. In planing these the point of the quadrant near the plane and the adjustable guides form the rest required for accurate work.

Surfaces are smoothly machined. Graduations accurately cut. Made entirely of iron, enameled black except bright parts polished.

Size 3½.

Width of knives, 3½ inches.

Weight boxed, 73 lbs.

Weight net, 53 lbs.

Price each, \$84.75

Code—Leaky

Extra plane knives, per pair, 3½ in., \$10.60.

Packed one in a wooden box.



Levels

Nos. 23-26



These levels are of the double plumb type, made entirely of iron. They are more compact, more durable and less expensive than the better grade of wooden levels.

Thorough inspection is made after each operation and the vials are tested both before and after setting. Surfaces are accurately machined and smoothly polished. Vials are protected with a nicked plate. All parts except top and base japanned black.

They are light, strong, and can be depended upon for absolute accuracy.

Nos.	23	24	25	26
Length	6 in.	12 in.	18 in.	24 in.
Weight each	14 oz.	2 lbs.	3½ lbs.	4½ lbs.
Price each	\$1.85	2.60	3.15	3.55
Code	<i>Level</i>	<i>Ledge</i>	<i>Leful</i>	<i>Leger</i>

Packed one in a box.

Ground glasses furnished at additional cost of \$.75 per glass.

Jointer Gauge

No. 88

ROSE TOOLS, INC.



This tool is easily and quickly attached to iron or wood planes, and enables the operator to accurately plane bevels of any desired angle, or to make even joints without using a try square or bevel.

Attached to iron planes of all sizes by adjustable cams; to wood planes by ordinary wood screws. Can be used on either side of plane, for right or left hand work.

Made entirely of iron. Enamelled black overall, except flat surface polished and nickel plated.

Length of guide 9 inches.

Weight each, 2¼ lbs.

Price each, \$2.30

Code—*Litra*

Packed one in a box.



Bench Hook



No. 56

Plumb Bobs



Nos. 1-4

No. 56

A strong, rigid tool easily inserted in any bench. Has four faces, adjustable to any desired position and height by means of set screws in center.

ROSE TOOLS, INC.

Steel hook, nickered. Inner surface of socket enameled red. Edge of socket polished.

Upper part of socket 2 inch and lower part 1 inch in diameter.

Weight each, 10 oz.

Code—*Livid*

Price each, \$1.15

Packed six in a box.

Nos. 1-4

These plumb bobs are machine turned from cold rolled steel. The points are sharpened and hardened; the round surfaces smoothly finished. Hang true and insure positive accuracy in plumbing and leveling.

Nos.	1	2	3	4
Length	2¾ in.	3½ in.	4 in.	5 in.
Weight each	3 oz.	6 oz.	9 oz.	14 oz.
Price each	\$.30	.35	.50	.70
Code	<i>Lloyd</i>	<i>Loach</i>	<i>Liver</i>	<i>Loany</i>

Packed six in a box.



Spoke Shaves

No. 2



This tool has an advantage over the ordinary spoke shave in that either handle is detachable, permitting the operator to work in narrow places.

The throat regulator is quickly adjustable and can be turned about to present four different faces to the knife, one flat, two oval or convex, and one concave. Either wide or narrow throat can be had.

Knife is adjustable by means of set screws, is of high grade steel, carefully tempered and sharpened.

Handles are cocobolo, highly polished. Metal parts are polished and nickel plated.

Length of blade, 2 inch.

Length overall 11 inches.

Weight each, 8 oz.

Price each, \$2.90

Code—Local

Packed six in a box.

No. 1

ROSE TOOLS, INC.

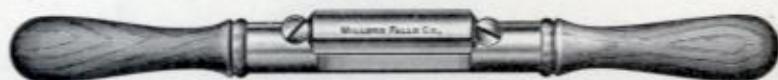

This tool is designed especially for working in small circles. The knife is so pitched that it cuts instead of scraping the grain of the wood.

Can be used in cramped places to advantage as either handle is detachable.

Knife is of high grade steel, carefully tempered and has keen cutting edge.

Handles are of cocobolo, highly polished. Metal parts, polished and nickel plated.

Length of blade 2 inch.

Length overall 10 inches.

Weight each, 7 oz.

Price each, \$1.60

Code—Locky

Packed six in a box.

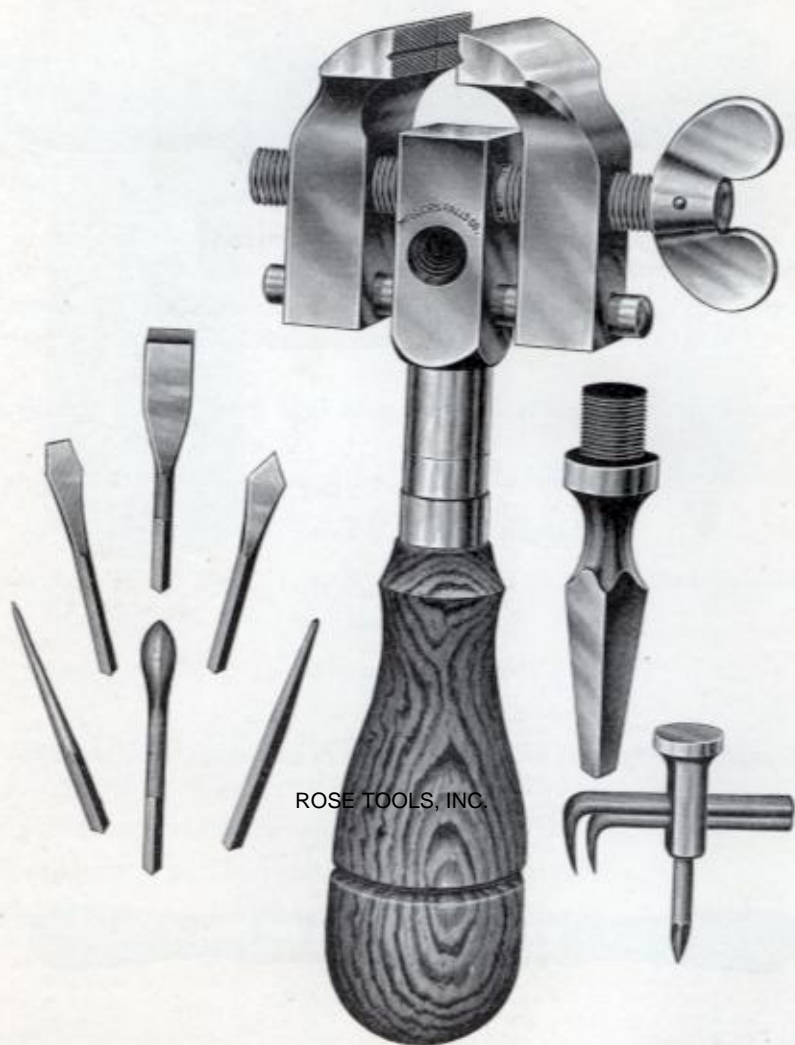
Hand Vise
No. 1

ROSE TOOLS, INC.

An exceptionally strong, well made vise, superior to the ordinary tool of this kind.

Handle is detachable and can be screwed into vise at right angles. Bit shank provided which can be screwed into the tool either in the position of the handle as shown in the illustration, or at right angles, permitting use in a bit brace.

Cocobolo handle, hollow end, containing chisel, screw driver, countersink, square reamer, bradawl, scratch awl and washer cutter.

Forged steel jaws. Steel screw. Exposed metal parts polished and nickel plated.

Length $6\frac{3}{4}$ inches.

Jaws open, 1 inch.

Width of jaws $1\frac{1}{4}$ inches.

Weight each, 17 oz.

Price each, \$5.10

Code—Raven

Packed one in a box.

Hand Vise

No. 2

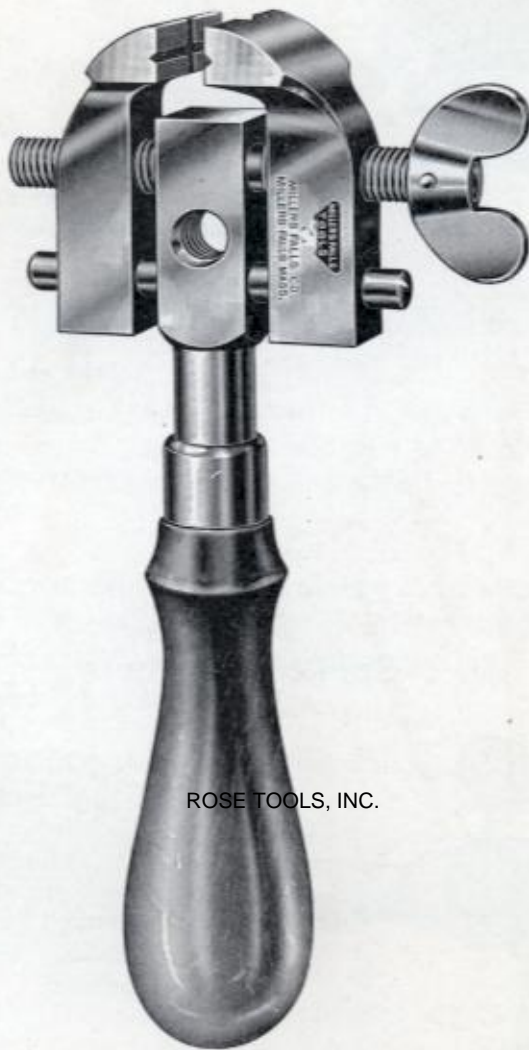

ROSE TOOLS, INC.

The main difference between this and No. 1 vise is in the handle, which is solid and of stained hardwood. It is detachable, however, same as No. 1.

Length 7 inches.

Width of jaws $1\frac{1}{4}$ inches.

Jaws open 1 in.

Weight each, 14 oz.

Price each, \$4.50

Code—Razor

Packed one in a box.

Hand Vise

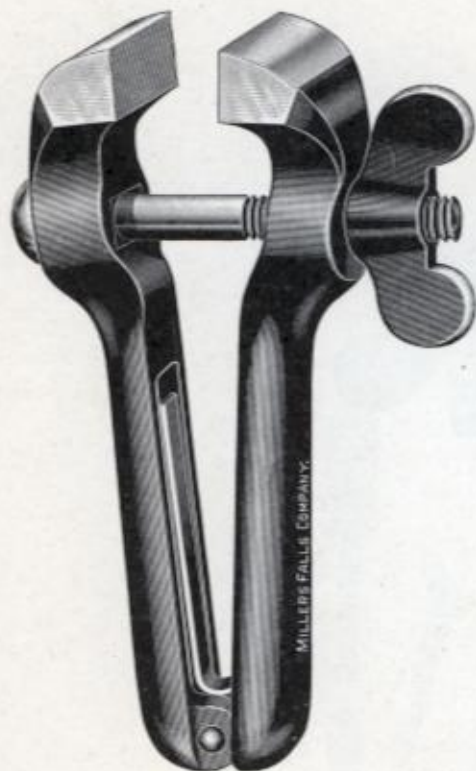

No. 3

This vise is made entirely of steel. Jaws are operated by a heavy spring, which is controlled by thumb nut and screw bolt. Jaws are checked to insure firm grip. Enameled black, except jaws are polished.

Length 5 inches.

Width of jaws $1\frac{1}{2}$ inches.

Jaws open $1\frac{1}{4}$ inches. Weight each, $1\frac{1}{8}$ lbs.

Price each, \$1.75

Code—Reaks

Packed one in a box.

Spoke Trimmers

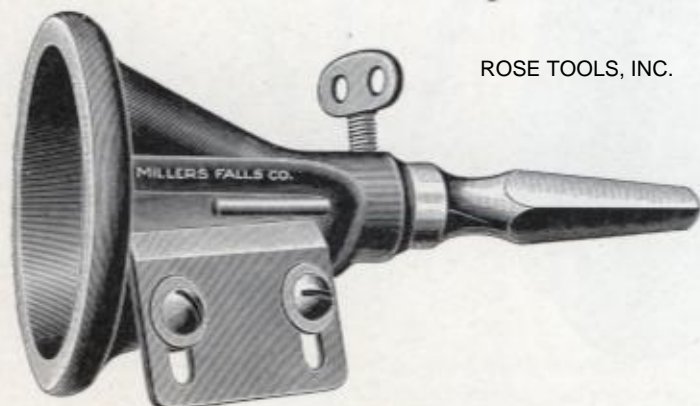

ROSE TOOLS, INC.

Nos. 101 and 102

Adjustable knife, sharpened and ready for use. Adjustable stop gauge, clamped with thumb screw. Iron casting, black enameled. Shank polished.

No.	Capacity	Weight each	Code	Price each
101	Round stock up to $1\frac{7}{8}$ in. Square stock up to $1\frac{5}{8}$ in.	7 oz.	Saxon	\$ 1.00
102	Round stock up to 3 in. Square stock up to $2\frac{1}{2}$ in.	$1\frac{1}{2}$ lbs.	Saucy	1.35

No. 101 will cut square stock up to $1\frac{7}{8}$ in. and No. 102 up to 3 in. if corners of wood are first trimmed.

No. 101 packed three and No. 102, two in a box.

Nos. 201 and 202

These are identical with Nos. 101 and 102 except that they have $\frac{1}{2}$ inch round shank.

No. 201

Code—Sevon

Price each, \$1.00

No. 202

Code—Sexey

Price each, \$1.35



NAIL SETS AND PUNCHES

In August, 1920, we acquired control of the West Haven Mfg. Co. of West Haven, Conn., which, in addition to "Universal" hack saw blades and frames, made a superior line of nail sets, punches and other small tools.

The accuracy, strength, and durability of these tools is the result of the care used in the selection of the steel from which they are made, the exacting processes of hardening and tempering, and the thorough inspection given to each tool.

The fact that our nail sets are machined enables us to produce *perfect* cups and points, an ROSE TOOLS, INC.er the average nail set cup which is slightly elliptical and therefore liable to chip off on one side. Also all our points are made over size with a bevel down to the point. For these reasons we claim to have the strongest and most accurate point of any nail set made.

The centers of the nail sets and punches are heavily knurled and afford a firm grip; the heads and points are machine finished and therefore absolutely accurate and true.

They can be depended upon to give satisfaction.

(Of special note are the square head nail sets, prick and center punches; new tools that have several advantages over the ordinary round head type.)



Nail Sets Square Head Nos. 451-455



The advantages of this type of head are many. Because of the larger striking surface the head will wear longer before it is rounded over. There is less chance of striking the set on an angle and therefore less sting on the fingers. It will not roll on an inclined surface. When carried in the pocket with other small tools it is easily picked out without removing the others.

Its convenience and durability will be appreciated by every carpenter and mechanic.

Nos.	Body	Length	Points	Weight per dozen	Price per dozen	Code
451	5/16 in.	4 in.	1/32 in.	17 oz.	\$1.75	<i>Macaw</i>
452	5/16 in.	4 in.	2/32 in.	17 oz.	1.75	<i>Macer</i>
453	5/16 in.	4 in.	3/32 in.	17 oz.	1.75	<i>Macho</i>
454	5/16 in.	4 in.	4/32 in.	17 oz.	1.75	<i>Madar</i>
455	5/16 in.	4 in.	5/32 in.	17 oz.	1.75	<i>Madia</i>
4501	One dozen assorted as listed below			17 oz.	1.75	<i>Madly</i>

Packed one dozen of a size, or assorted, in a box.

Unless otherwise specified, the following assortment will be furnished: two each 1/32 and 4/32 inch; Four each 2/32 and 3/32 inch.

Square Head Nail Set Display No. 4500

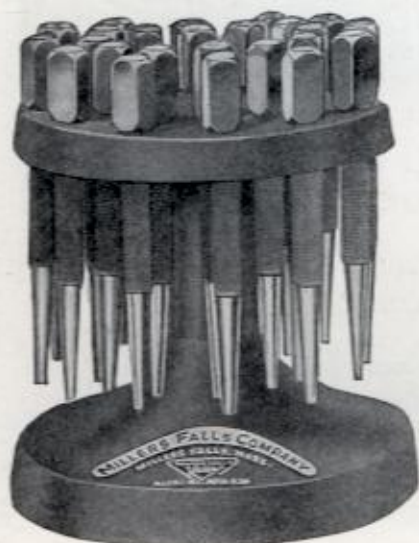

ROSE TOOLS, INC.

The illustration does not do justice to this new display. It is a handsome device, enameled Millers Falls red, on the base of which is a decalcomania with our name and trade mark.

It takes up but little space on the counter and will turn stock rapidly. The display holds 24 square head nail sets and is given free with the first order for three dozen of nail sets Nos. 451-455 or 4501 either straight or assorted sizes.

Diameter of base $4\frac{3}{4}$ inches.

Height, including nail sets, $5\frac{1}{2}$ inches.

Weight, including 3 doz. nail sets, $3\frac{3}{4}$ lbs.

Code—*Madre*



"O K" Nail Sets

No. 310



Made in both bright and blued finish. Blued furnished, unless bright is specified.

Body	Length	Points	Weight per dozen	Prices per dozen	Codes
9/32	4 in.	1/32 in.	13 oz.	\$1.40	Magie
5/16	4 in.	2/32 in.	13 oz.	1.40	Magna
5/16	4 in.	3/32 in.	13 oz.	1.40	Magot
5/16	4 in.	4/32 in.	13 oz.	1.40	Magus
5/16	4 in.	5/32 in.	13 oz.	1.40	Mahol

Packed one dozen of a size, or assorted sizes, in a box.

Unless otherwise specified, the following assortment will be furnished: Two each 1/32 and 4/32 inch; four each 2/32 and 3/32 inch.

Display Sets

No. 324

This set contains twenty-four assorted No. 310 Nail Sets. Boxes are of hardwood, covered with paper.

Weight, per set, 1 lb., 10 oz. Price, per set, \$3.05
Code—Maian

No. 312

This set contains twelve assorted sizes No. 310 Nail Sets. Box and cover of hardwood, nicely polished.

Weight, per set, 1 lb. Price, per set, \$1.60
Code—Maine



Large Nail or Spike Sets



Nos.	Body	Length	Points	Weight per dozen	Price per dozen	Codes
338	3/8 in.	5 in.	2, 3, 4, 5, 6/32 in.	1 1/2 lbs.	\$2.20	Maize
339	7/16 in.	5 in.	1/4 in.	2 1/4 lbs.	2.75	Major
340	1/2 in.	5 in.	5/16 in.	2 3/4 lbs.	3.25	Majun
341	Assorted			1 3/4 lbs.	2.75	Malac

Packed one dozen in a box.



Center Punches

Square Head No. 460



Bright finish. Body $5/16$ inch diameter. Head $3/8$ inch square. Length overall 4 inches.
Weight per dozen, 17 oz. Price per dozen, \$1.75

Code—Malta

Packed one dozen in a box.

"O. K." Nos. 140-146



Shank and Head Polished.

Nos.	Body	Length	Weight per dozen	Price per dozen	Code
140	$9/32$ in.	4 in.	$3/4$ lbs.	\$1.35	Malum
141	$5/16$ in.	4 in.	$3/4$ lbs.	1.35	Malma
142	$3/8$ in.	4 in.	$1\frac{1}{4}$ lbs.	1.75	Manch
143	$3/8$ in.	5 in.	$1\frac{1}{2}$ lbs.	2.10	Mango
144	$7/16$ in.	4 in.	$1\frac{3}{4}$ lbs.	2.10	Mania
145	$1/2$ in.	4 in.	$2\frac{1}{4}$ lbs.	2.40	Manks
146	$1/2$ in.	5 in.	$2\frac{1}{2}$ lbs.	2.80	Manse

Packed one dozen in a box.

No.	Assortment	Weight per dozen	Price per dozen	Code
1401	6 each $9/32$ and $5/16$ in.	$3/4$ lbs.	\$1.35	Manul
1402	4 each $3/8$, $7/16$ and $1/2$ x 4 inch.	1 lb.	2.10	Maray



Prick Punches Square Head No. 470



Bright Finish. Body $5/16$ inch diameter. Head $3/8$ inch square. Length overall 4 inches.
Weight per dozen, 17 oz. Price per dozen, \$1.75

Code—Mares

Packed one dozen in a box.

"O. K." Nos. 166-169

ROSE TOOLS, INC.



Point and head polished.

Nos.	Body	Length	Weight per dozen	Price per dozen	Code
166	$9/32$ in.	4 in.	$3/4$ lb.	\$1.65	<i>Marie</i>
167	$5/16$ in.	4 in.	$3/4$ lb.	1.65	<i>Marry</i>
168	$3/8$ in.	4 in.	$1\frac{1}{4}$ lb.	2.00	<i>Marsh</i>
169	$3/8$ in.	5 in.	$1\frac{1}{2}$ lb.	2.50	<i>Marta</i>

Packed one dozen in a box.

MILLERS FALLS COMPANY



"O. K." Solid Drive Punches

Nos. 180-186



Point and head polished.

Nos.	Body	Length	Points	Weight per dozen	Code	Price per dozen
180	$\frac{3}{16}$ in.	4 in.	$\frac{1}{8}$ in.	$\frac{3}{4}$ lbs.	<i>Media</i>	\$1.35
181	$\frac{3}{8}$ in.	4 in.	$\frac{3}{16}$ in.	$1\frac{1}{4}$ lbs.	<i>Medle</i>	1.60
182	$\frac{3}{8}$ in.	5 in.	$\frac{3}{16}$ in.	$1\frac{1}{2}$ lbs.	<i>Medoc</i>	2.00
183	$\frac{7}{16}$ in.	4 in.	$\frac{1}{4}$ in.	$1\frac{3}{4}$ lbs.	<i>Meech</i>	2.00
184	$\frac{7}{16}$ in.	5 in.	$\frac{1}{4}$ in.	2 lbs.	<i>Meiny</i>	2.40
185	$\frac{1}{2}$ in.	4 in.	$\frac{5}{16}$ in.	$2\frac{1}{4}$ lbs.	<i>Melee</i>	2.30
186	$\frac{1}{2}$ in.	5 in.	$\frac{5}{16}$ in.	$2\frac{3}{4}$ lbs.	<i>Melic</i>	2.70

Packed one dozen in a box.

Nos.	Assortment	Weight	Code	Price per dozen
1800	3 each of the 4 in. lengths	$1\frac{3}{4}$ lbs.	<i>Melon</i>	\$2.00
1801	4 each of the 5 in. lengths	$2\frac{1}{4}$ lbs.	<i>Menge</i>	2.40

"O. K." Drive Pin Punches

Nos. 380-384



Point and head polished.

Nos.	Body	Length	Points	Weight per dozen	Code	Price per dozen
380	$\frac{1}{16}$ in.	4 in.	$\frac{1}{8}$ in.	$\frac{3}{4}$ lbs.	<i>Merge</i>	\$1.55
381	$\frac{1}{16}$ in.	4 in.	$\frac{3}{32}$ in.	1 lbs.	<i>Merit</i>	1.55
382	$\frac{3}{8}$ in.	4 in.	$\frac{3}{16}$ in.	$1\frac{1}{4}$ lbs.	<i>Merke</i>	1.55
383	$\frac{3}{8}$ in.	4 in.	$\frac{3}{32}$ in.	$1\frac{1}{4}$ lbs.	<i>Mesad</i>	1.55
384	$\frac{3}{8}$ in.	4 in.	$\frac{1}{4}$ in.	$1\frac{1}{4}$ lbs.	<i>Meson</i>	1.55

Packed one dozen in a box.



Display Set

No. 3801

Contains five punches, one each of Nos. 380-384. Boxes of hard-wood, covered with red paper.

Weight per set, $\frac{1}{2}$ lb.

Price per set, \$.70

Code—*Mesua*

"O. K." Drive Pin Punches

Nos. 480-483



Point and head polished.

Nos.	Body	Length	Points	Weight per dozen	Code	Price per dozen
480	1/2 in.	6 in.	3/16 in.	2 1/2 lbs.	<i>Metal</i>	\$3.35
481	1/2 in.	6 in.	1/4 in.	2 3/4 lbs.	<i>Meter</i>	3.35
482	1/2 in.	6 in.	5/16 in.	2 3/4 lbs.	<i>Metic</i>	3.35
483	1/2 in.	6 in.	3/8 in.	3 1/4 lbs.	<i>Miaul</i>	3.35

Packed one dozen in a box.

Display Sets

No. 4800

Contains three each of Nos. 480-483, packed in hardwood box, covered with red paper. Same style box as No. 385, page 156.

Weight each 3 lbs. Price each, \$3.50

Code—Miask

No. 4801

Contains one each Nos. 480-483, packed in pasteboard box.

Weight each 1 lb. Price each, \$1.05

Code—Micro

Nos. 490-493

ROSE TOOLS, INC.



Point and head polished.

Nos.	Body	Length	Points	Weight per dozen	Code	Price per dozen
490	1/2 in.	9 in.	3/16 in.	3 1/4 lbs.	<i>Midge</i>	\$4.75
491	1/2 in.	9 in.	1/4 in.	3 3/4 lbs.	<i>Midst</i>	4.75
492	1/2 in.	9 in.	5/16 in.	4 lbs.	<i>Mites</i>	4.75
493	1/2 in.	9 in.	3/8 in.	5 1/2 lbs.	<i>Milky</i>	4.75
4900	Three each of above punches			4 lbs.	<i>Mince</i>	4.75

Packed one dozen in a box.

Set No. 4901

Contains one each Nos. 490-493 punches, packed in a box.

Weight per set, 1 1/2 lbs.

Price per set, \$1.65

Code—Miner



Center Punch Set No. 3 C. P.



Three "O.K." tool makers' center punches mounted on an attractive display card. Set contains one each of the following sizes:

Body	Length
$\frac{3}{16}$ in.	$2\frac{1}{4}$ in.
$\frac{1}{4}$ in.	$2\frac{3}{4}$ in.
$\frac{5}{16}$ in.	4 in.

Weight per set, 1 oz.

Code—*Minow*

Price per set, \$.35

Packed six sets in a box.

"O. K." Light Drive Pin Punches



Set No. 36

Three "O.K." Light Pin Punches mounted on an attractive display card. Set contains one each of following sizes:

Body	Length	Points
$\frac{3}{16}$ in.	$2\frac{1}{4}$ in.	$\frac{1}{16}$ in.
$\frac{1}{4}$ in.	$2\frac{3}{8}$ in.	$\frac{3}{64}$ in.
$\frac{5}{16}$ in.	$2\frac{1}{2}$ in.	$\frac{3}{32}$ in.

Weight per set, 1 oz.

Price per set, \$.40

Code—*Mirza*

Packed six sets in a box.



Set No. 37

These are the same style of punches as those in No. 36 set, but are larger. Set contains one each of following sizes:

Body	Length	Points
$\frac{1}{4}$ in.	$2\frac{3}{4}$ in.	$\frac{3}{16}$ in.
$\frac{1}{4}$ in.	$2\frac{7}{8}$ in.	$\frac{1}{4}$ in.
$\frac{1}{4}$ in.	3 in.	$\frac{1}{8}$ in.

Weight per set, 1 oz.

Price per set \$.50

Code—*Miser*

Packed six sets in a box.



Sets of Punches

No. 100 R

Ten assorted four-inch Punches, packed in a neat canvas roll. Set comprises the following:

- One each Pin Punches No. 380 series.
- One Drive Pin Punch No. 180.
- One Prick Punch No. 166.
- One each Center Punches Nos. 140, 142 and 145.

Weight per set, 14 oz.

Price per set, \$1.65.

Code—Mixed

Packed six sets in a box.



ROSE TOOLS, INC.

No. 485

Five assorted Punches of the following numbers, packed in canvas roll:

- One Center Punch No. 143.
- One each Drive Pin Punch No. 480 series.

Weight per set, 17 oz.

Price per set, \$1.60

Code—Mixed

Packed six sets in a box.





Sets of Punches

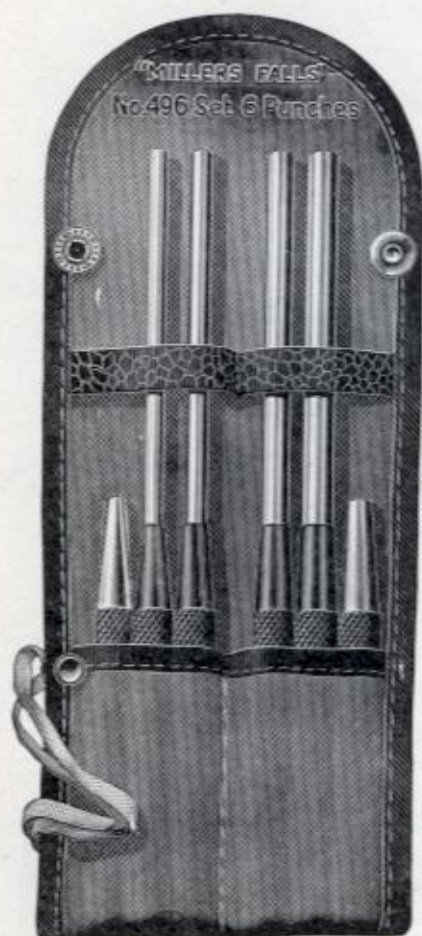

No. 496

Six assorted Punches, in canvas roll. Set comprises four 9 inch and two 4 inch of the following numbers:

One each Drive Pin Punches No. 490 series.

One each Solid Drive Punches Nos. 181 and 185.

Weight per set, 1 $\frac{5}{8}$ lbs.

Price per set, \$2.60

Code—Moano

Packed six sets in a box.

ROSE TOOLS, INC.

No. 385



Twenty-four assorted 4 inch Punches, packed in a strong hardwood box for counter display. Assortment comprises the following numbers:

Six Center Punches No. 142.

Six Prick Punches No. 168.

Two Solid Drive Punches No. 181.

Two each Drive Pin Punches No. 380 series.

Weight per set, 2 $\frac{1}{4}$ lbs.

Code—Mobby

Price per set, \$3.60



AUTO TOOLS

New tools and improvements to tools already established have brought this important Millers Falls line to an even higher standard.

Two truck Jacks of the ratchet, ball bearing type, and an improved Valve Grinder are the most important additions. The former are used as standard equipment on two nationally known motor trucks which is conclusive proof of their merits.

ROSE TOOLS, INC.

No. 145 Auto Jack continues to grow in popularity and probably has the largest sale of any extensible handle Jack on the market.

Strength in construction, combined with practical design characterize each of the tools shown on the following pages. They can be depended upon to give lasting service and satisfaction.



Auto Jack

No. 145

Ease of operation, convenience and dependability characterize No. 145 Auto Jack. It can be placed under car, operated, and removed without stooping, reaching under car, or soiling hands or clothes.

A feature not found in any other jack is the quick adjusting device, by which the screw can be lifted to its full height, or instantly released, by simply lifting the worm gear.

Another distinguishing feature is the adjustable base, which permits three ranges of height before screw is raised.

It can be depended upon to lift to its full capacity easily, quickly and under all road conditions.



ROSE TOOLS, INC.

Specifications

Ball bearing end thrust. All working parts of steel. Base grey iron, checked on bottom. Barrel, malleable iron. Cap, saddle shaped, corrugated top. Cap and screw of one piece forged steel, practically unbreakable cannot be screwed out of barrel. Handle of steel tubing, with steel telescopic rod, extensible to 36 inches. Quick setting locking pin on handle.

Handsomely finished a lustrous black overall, except thin red stripe around base.

Minimum height, 9½ in. Maximum height, 18 in.
Capacity, 2 tons. Weight (with handle), 10½ lbs. Price, \$5.00

Code—Nadir

Auxiliary base (4 in. x 6 in.) for use on very soft ground \$.50

Code—Nabit

Packed one in a carton, twelve in a case.





Ratchet Truck Jacks

New

Nos. 160-165

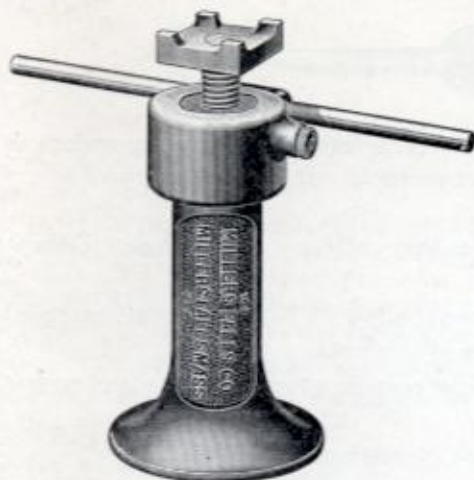

In designing this truck jack we have profited by 20 years experience in the building of jacks for lifting purposes.

It is built for rough hard usage—is simple in construction, has the fewest possible working parts, and designed to operate easily under all road conditions.

Special features

Ball-bearings set in upper section prevent any chance of binding.

All working parts enclosed—positively dirt proof.

Permanently lubricated when assembled. No loss in self contained housing. Therefore no need for further lubrication.

ROSE TOOLS, INC.

Special type cap fits any shape axle.

Positive ratchet action—reversed by turning pawl knob.

Improved locking device holds entire assembly intact.

Extra large base prevents any chance of overturning even at the maximum height.

Steel lifting screw, ball bearings and lever. Other parts, cast iron.

Enameled black overall.

Specifications

Minimum height.....	No. 160 12 inch	No. 165 10 ⁷ / ₈ inch
Maximum height.....	19 ³ / ₄ inch	17 ⁵ / ₈ inch
Maximum lift.....	7 ³ / ₄ in.	6 ³ / ₄ inch
Estimated capacity.....	15 ton	7 ¹ / ₂ ton
Diameter of lift screw.....	1 ³ / ₄ inch	1 ³ / ₈ inch
Diameter of base.....	7 inch	6 ¹ / ₄ inch
Weight with lever.....	30 lbs.	19 ³ / ₈ lbs.
Price each.....	\$12.00	\$10.00
Code.....	Naris	Narre

No. 160 packed twelve in a case.

No. 165 packed eighteen in a case.



Bearing Scraper

No. 240

New



A new bearing scraper distinguished from the common type in having two working ends; one with the regular taper point, the other squared to allow flat scraping. It is therefore two tools in one.

Edges are ground concave with proper clearance for free easy cutting. Can be easily resharpened.

Another feature of superiority is that it is made of special alloy TUNGSTEN steel hardened and tempered by experts with years of experience in the use of this steel.

Handle is of hard rubber, practically unbreakable. Shape permits a firm, easy grip, and perfect balance.

Length overall, 12 $\frac{3}{4}$ in.

Length of cutting edges, 2 $\frac{1}{4}$ in.

Weight, each, 6 oz.

Price each, \$1.05

Code—Nasus

Packed one in a box.

Valve Grinder

No. 238

Improved

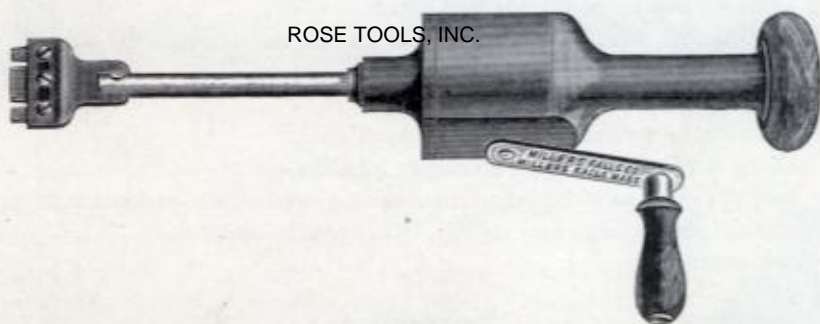

ROSE TOOLS, INC.

An improved tool which simplifies the grinding of automobile valves. Forward turns of the crank cause grinding head to reciprocate and make one complete revolution to ten turns of the crank. Ball bearings insure free action and increase its power.

Universal in its use as spanner points are adjustable and the flat blade is used for slotted valve heads.

Steel gears and crank handle, iron frame enameled black. Head of stained hardwood, shaped to give firm, comfortable grip.

Length overall 13 $\frac{3}{8}$ inches.

Length of spindle, 5 $\frac{3}{4}$ inches.

Weight each, 2 lbs. 7 oz.

Code—Natal

Price each, \$3.40

Packed one in a box.



Valve Grinders

No. 235



This valve grinder is of the popular brace type. It is equipped with a universal working head, having an adjustable spanner and flat blade, to fulfill the requirements of different types of valve heads. The working head is attached to the sweep so that there is a slight play in all lateral directions. This decreases the chance of the spanner or blade slipping out of engagement with the spanner holes or slot in the valve head.

Head and handle stained hardwood, free acting, secured by metal bearings. Steel rod, polished.

Sweep, 4 inch radius. Length below sweep, 6½ inches. Length overall 15 inches.

Weight each, 13 oz.

Code—Natch

Price each, \$.75.

Packed six in a box.

No. 236



This differs from No. 235 in the type of working head and length overall. It is made for use on Ford cars and designed especially for the Ford construction.

The working head has a non-adjustable spanner in the spanner hole in the top of Ford valve.

Length below sweep, 12½ inches. Length overall, 21 inches.

Otherwise same as No. 235.

Weight each, 15 oz.

Code—Nates

Price each, \$.60

Packed six in a box.

No. 237



This tool is the same as No. 235 except has round shank for use with bit brace or hand drill, instead of a complete brace sweep.

Shank ¾ x 4 in.

Weight each, 4 oz.

Price each, \$.50

Code—Natka

Packed six in a box.



Ratchet Tap Wrench

New

No. 58

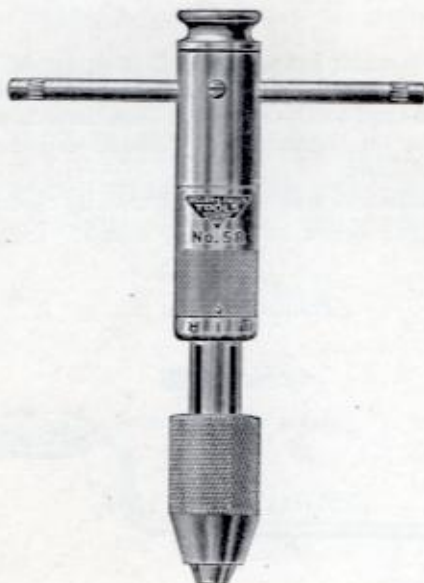

ROSE TOOLS, INC.

An efficient tool for working in close quarters and in places inaccessible with an ordinary Tap Wrench.

Ratchet operates by means of cam in rear of shifter sleeve. Ratchets to right or left by turning shifter ring. In center is solid for use without ratchet.

Handle is held firmly in position by set screw. Knob at top affords a means of steadying the Wrench while starting the tap.

Ratchet and pawls of tool steel. Steel jaws hardened and tempered. Case hardened sleeve.

Length of handle, $3\frac{1}{2}$ in.

Length overall, $4\frac{3}{4}$ in.

Capacity up to $\frac{1}{4}$ in. Taps.

Polished overall.

Weight each 7 oz.

Price each, \$1.90.

Code—Necto

Packed two in a box.



Tap Wrenches

Nos. 10-12

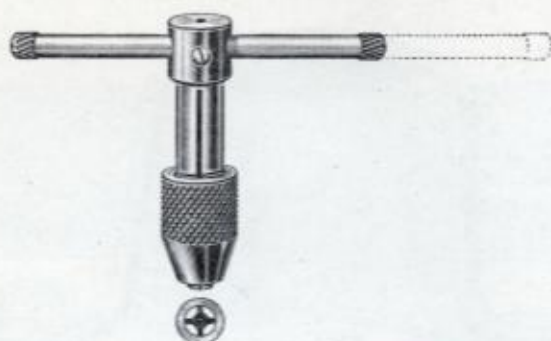

This tool is designed for holding taps, reamers, small drills, or other small tools. It is superior to similar wrenches, because of its slide handle, which permits its use in many places where a rigid handle cannot be turned.

For ordinary work handle can be set rigid by means of a set screw.

Chuck shell is knurled. Jaws are tempered, sleeve is case hardened. Centers accurately.

Nos.	Length of Handle	Capacity	Weight each	Price each	Code
10	3 $\frac{1}{4}$ in.	Up to $\frac{1}{4}$ in.	2 oz.	\$.60	Naval
11	4 $\frac{3}{4}$ in.	Up to $\frac{3}{8}$ in.	4 oz.	.75	Navy
12	5 $\frac{1}{4}$ in.	Up to $\frac{1}{2}$ in.	8 oz.	1.10	Navic

Nos. 10 and 11 packed six, and No. 12, two in a box.

Set No. 112

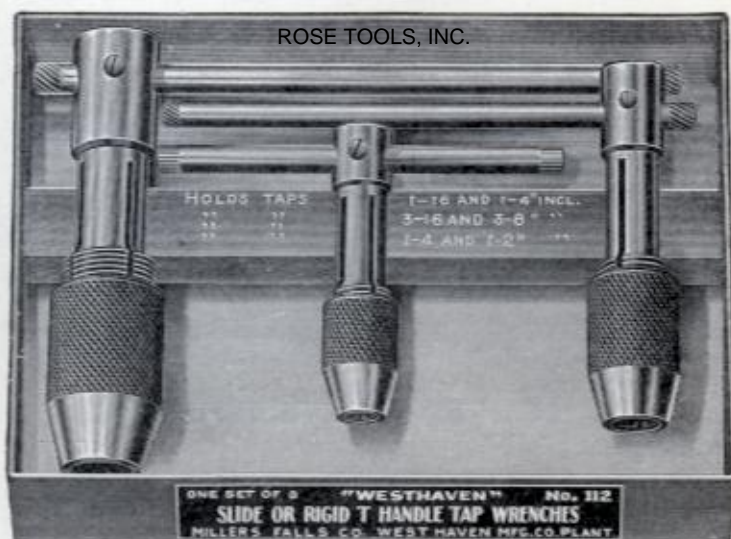

Contains one each Nos. 10, 11 and 12 Tap Wrenches packed in a box.

Weight per set, 18 oz.

Code—Navy

Price per set, \$2.50



Rim Wrenches

Nos. 810-814

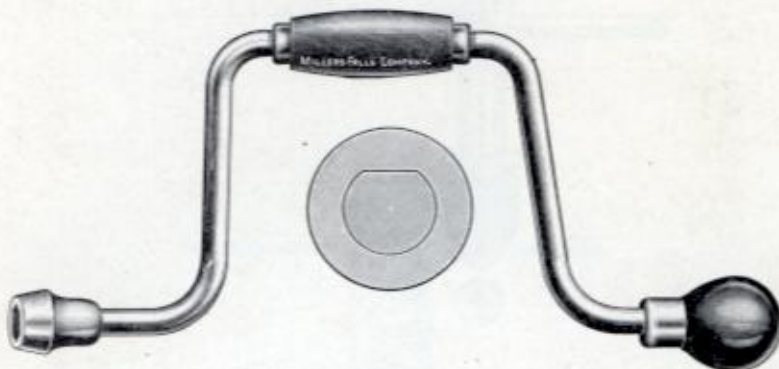

This wrench has many features of superiority over the ordinary type generally furnished in automobile kits.

Socket is extra strong to resist cracking at the corners, or wearing of the sides of the hexagon; and is broached accurately to size.

To prevent possible loosening the rod is flattened on one side to fit against a flat surface in the socket.

Free acting sweep handle; knob handle gives an easy and comfortable grip.

Polished sweep rod. Handles, hardwood, stained and polished. 10 inch sweep.

Nos.	810	811	812	813	814
Size of socket by 16ths	10	11	12	13	14
Weight each	1¼ lbs.	1¼ lbs.	1¼ lbs.	1¼ lbs.	1¼ lbs.
Price each	\$.80	ROSE TOOLS, INC.	.80	.80	.80
Code	Narwe	Nasal	Nasky	Nassa	Nasid

Packed six in a box.

"O K" Assembling Tool

No. 2



This tool is especially useful in automobile repairing and assembling, being used to line up holes through which pins, bolts, screws, etc., are to be placed.

Made of tool steel, spring tempered. Handle, heavily knurled. Taper polished.

Body	Point	Length	Weight each	Price each	Code
½ in.	3/16 in.	10 in.	6 oz.	\$.55	Needy

Packed six in a box.



Soldering Sets

No. 1



With this set the repairing of small leaks in the radiator, water pump, household utensils, etc., is easily and quickly done.

The copper can be used as an ordinary soldering copper or attached to a gas burner. Handle is hollow with holes directly beneath the copper.

Set consists of soldering copper, bar of solder, box of resin and a scraper.

Weight each, 14 oz.

Price each, \$1.35

Code—Scarf

Packed one set in a wooden box.

(Coppers only, with handle, each \$0.75)

No. 2

ROSE TOOLS, INC.



Differs from No. 1 only in the handle, which is solid and not adapted for use with a gas burner.

Weight each, 15 oz.

Price each, \$1.15

Code—Scent

Packed one set in a wooden box.

(Coppers only, with handle, each \$0.70)



Jack Screws

Nos. 1-20



These jacks are heavier, more accurately made, have easier action and are more durable than the ordinary jack screw.

Screws are forged from Bessemer steel. Threads are lathe cut, and mesh perfectly with the barrel. Swivel caps are securely held to screw. Tops are either checked, or have raised ribs to prevent slipping. Barrels are cast iron. Base is broad. Enameled black overall.

Nos.	Diameter of Screw Inches.	Height of Barrel Inches.	Minimum Height of Jack Inches.	Net Rise Inches.	Maximum Height of Jack Inches.	Weight Lbs.	Estimated Lifting Capacity Tons.	*Code With Lever.	Price With Lever.	Price Without Lever.
1	1 1/4	6	9	4	13	8 1/2	5	Rodeo	\$ 5.25	\$ 4.90
2	1 1/4	7	10	6	16	9 1/2	5	Rodge	5.90	5.55
3	1 1/2	7	10 3/4	5	16	16	8	Rogue	7.10	6.75
4	1 1/2	9	12 3/4	7	20	20 1/2	8	Royal	8.30	8.00
5	1 1/2	11	14 3/4	9	22	22 1/2	8	Rohan	9.50	9.20
6	1 3/4	9	12 3/4	6	18	22 1/2	12	Rohob	9.75	9.40
7	1 3/4	10 1/2	14 3/4	8	22	25	12	Roman	11.00	10.60
8	1 3/4	12 1/2	16	10	26	29	12	Rompu	11.60	11.25
9	1 3/4	14 1/2	18 1/4	12	30	32	12	Rondo	12.75	12.40
10	2	8	12 3/4	5	17	27	15	Rooky	12.90	12.50
11	2	10	14	7	21	31	15	Roost	13.65	13.30
12	2	12	16 1/4	9	25	35	15	Roper	14.25	13.85
13	2	16	20 1/4	13	33	41	15	Rogue	15.50	15.15
14	2 1/2	9 1/2	15	8	23	45 1/2	20	Roric	15.50	15.00
15	2 1/2	11 1/2	16 3/4	10	27	50	20	Rosal	16.50	15.90
16	2 1/2	15 1/2	20 3/4	14	35	62	20	Roseo	18.25	17.70
17	2 1/2	19 1/2	25	18	43	75	20	Rosin	20.75	20.25

CAR JACKS.

17 1/2	2	6	10	4	14	19 1/2	15	Rotal	\$ 10.50	\$ 10.20
18	2	8 1/2	12 1/2	5	17	25	15	Rotor	11.60	11.20
19	2	10 1/2	14 1/4	7	21	29	15	Rough	12.60	12.20
20	2	12	16	9	25	35	15	Rouse	13.60	13.20

N.B.—Jackscrews are furnished with levers unless ordered without.

Jackscrew Nos.	1, 2, 3, 4, 5	6, 7, 8, 9	10, 11, 12, 13	14, 15, 16, 17
Diameter of Lever.....	5/8 in.	3/4 in.	13/16 in.	1 in.
Length of Lever.....	17 in.	18 in.	19 in.	24 in.
Weight of Lever.....	1 1/2 lbs.	2 1/4 lbs.	2 3/4 lbs.	5 1/4 lbs.
Price of Lever.....	\$0.45	0.45	0.55	0.65

* For code word of jackscrews without lever, prefix "no" to code word for same number with lever; e.g., No. 1 without lever, *Norodeo*; No. 2 without lever, *Norodge*.



POLISHING HEADS

Millers Falls Polishing and Grinding Heads fill a real need in every shop, whether large or small. There are innumerable uses for these tools, particularly in the way of repair work on automobiles, trucks, tractors and similar equipment.

Millers Falls heads combine strength without extra weight and are accurate and smooth running. The base is cast in one piece, and is well ribbed to give strength and rigidity; spindles and collars are lathe turned; adjustable bearings provide for take-up on the spindles; pulleys on smaller polishing heads are grooved for round belts, but have three-quarter inch face for flat belts as well. Lubrication is supplied through improved oil caps. Every head is attractively finished, having black japanned frame with red bearing housings.

The Millers Falls line embraces nine different heads, and meets every shop requirement.

Polishing Heads

No. 250

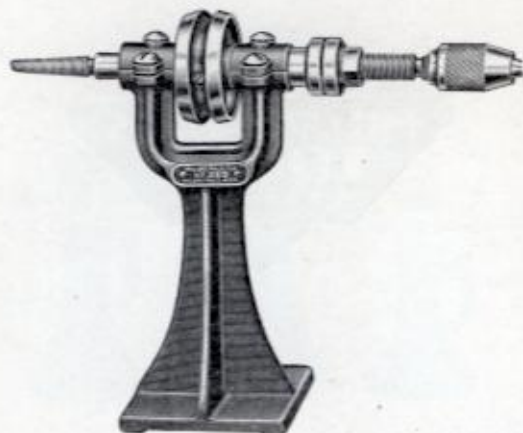

This is a small, well proportioned head which will accommodate wheels 1 inch thick and with $\frac{1}{2}$ inch hole. Tapered end of spindle takes felt, or other cloth buffing wheels. Equipped with Millers Falls 3-jaw chuck with capacity 0-3/16 inch round shanks.

Specifications

Flanges adjustable from 0- $\frac{7}{8}$ inches, securely locked by nut. Pulley grooved for $\frac{1}{4}$ inch round belt or the $\frac{3}{4}$ inch face can be used for flat belt.

Height to center of spindle 6 inches. Diameter of spindle $\frac{1}{2}$ inch. Base measures $2\frac{3}{4}$ in. x $2\frac{3}{4}$ in.

Diameter of pulley 1-13/16 in.

Weight $2\frac{1}{4}$ lbs.

Price each, \$2.90

Code—Pachy

Packed one in a box.

ROSE TOOLS, INC.

No. 251

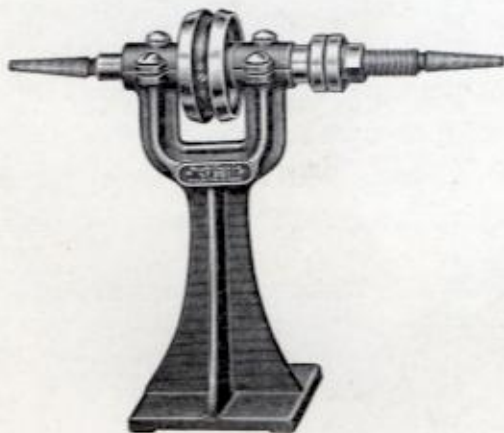

Identical with No. 250 except is not equipped with chuck.

Price each, \$2.40

Code—Padar

Packed one in a box.

Polishing Heads

No. 252

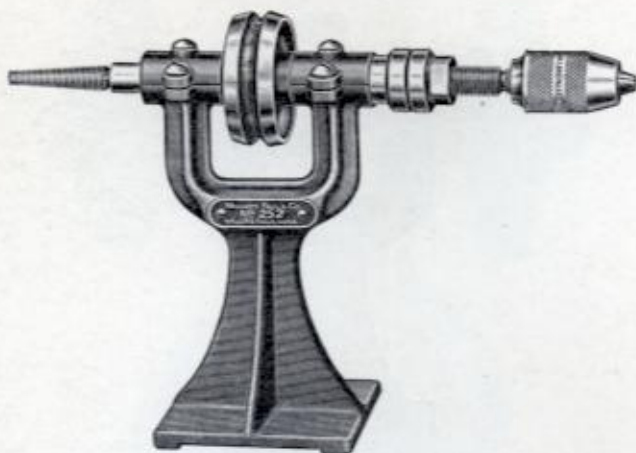

This head is of the same general construction as No. 251 but is larger and heavier. Takes wheels 1 inch thick with $\frac{1}{2}$ inch hole. Equipped with Millers Falls 3-jaw chuck, with capacity $0-\frac{1}{4}$ inch round shanks. Height to center of spindle 6 inches. Diameter of spindle $\frac{9}{16}$ inch. Base measures $3\frac{1}{4}$ in. x $3\frac{1}{4}$ in. Diameter of pulley $2\frac{1}{4}$ inch. Weight $3\frac{1}{4}$ lbs. Price each, \$4.65

Code—Padre

Packed one in a box.

No. 253

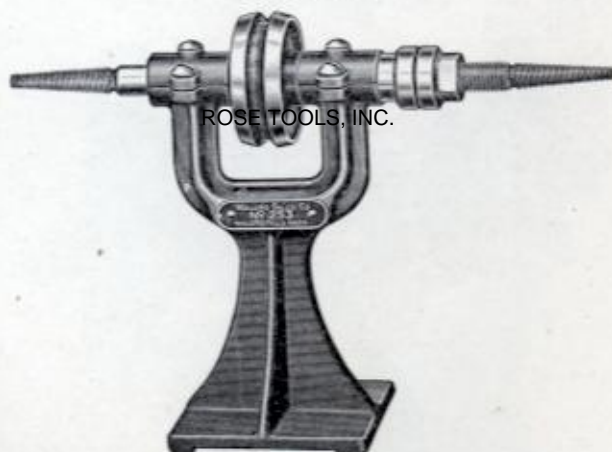

ROSE TOOLS, INC.

Identical with No. 252 except is not equipped with chuck.

Price each, \$3.40

Code—Pagan

Packed one in a box.

No. 256

This head has frame same as No. 255 on next page, but with spindle same design as No. 252. Spindle takes grinding wheels $\frac{3}{4}$ inch thick and $\frac{1}{2}$ inch hole, and a Millers Falls chuck with capacity up to $\frac{1}{4}$ inch; opposite end threaded taper to hold buffing wheels. Base measures 5 in. x 5 in.

Weight $9\frac{1}{4}$ lbs.

Code—Pagot

Price each, \$7.50

Packed one in box.



Grinding Heads

No. 254

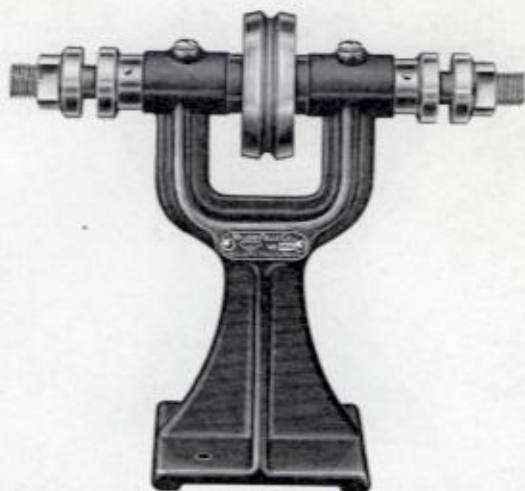

The only difference between this and No. 253 is in the design of the spindle. Takes wheels $\frac{5}{8}$ inch thick with $\frac{1}{2}$ inch hole.

Flange adjustable from 0 to $\frac{1}{2}$ inch. Securely locked by nut. Pulley grooved for $\frac{1}{4}$ inch round belt or the $\frac{3}{4}$ inch face can be used for flat belt. Height to center of spindle 6 inches.

Diameter of spindle $\frac{9}{16}$ inch. Diameter of pulley 2 inches. Base measures $3\frac{1}{4}$ inch x $3\frac{1}{4}$ inch.

Weight 4 lbs.

Code—Paise

Price each, \$4.10

Packed one in a box.

ROSE TOOLS, INC.

No. 255



This is one of our newer types, somewhat different in design. Exceptionally well proportioned. Improved oil caps protect bearings from dirt.

The spindle holds on either end grinding wheels $\frac{3}{4}$ inch thick with $\frac{1}{2}$ inch hole.

Steel pulley takes $1\frac{1}{4}$ inch belt.

Height to center of spindle $7\frac{1}{2}$ inches.

Diameter of spindle $\frac{3}{4}$ inch.

Diameter of pulley $1\frac{3}{8}$ inch.

Base measures 5 inch x 5 inch.

Weight $9\frac{1}{4}$ lbs.

Code—Paleo

Price each, \$6.25

(No emery wheels are furnished.)

Packed one in a box.



Grinding Heads

No. 257

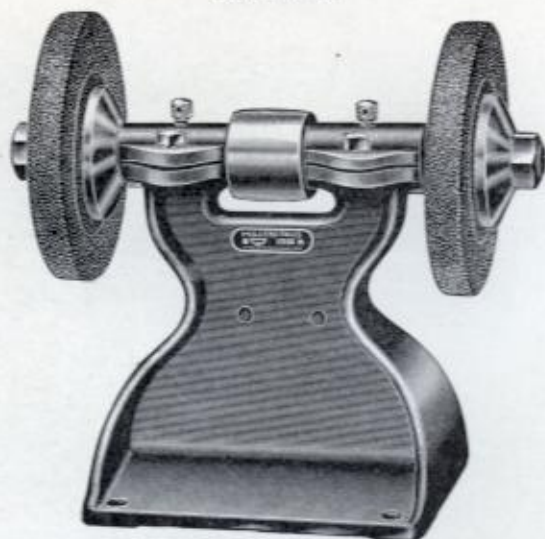

Although larger and heavier, has the same frame construction as No. 255. Spindle takes grinding wheels 1 inch thick with $\frac{3}{4}$ inch hole.

Steel pulley takes $1\frac{1}{2}$ inch belt.

Height to center of spindle $10\frac{1}{4}$ inches.

Diameter of spindle 1 inch. Base measures 8 inch x 8 inch. Diameter of pulley $1-15/16$ inches.

Weight $26\frac{1}{2}$ lbs.

Code—Palmy

Price each, \$12.60

(No emery wheels are furnished.)

Packed one in a box.

No. 258

ROSE TOOLS, INC.

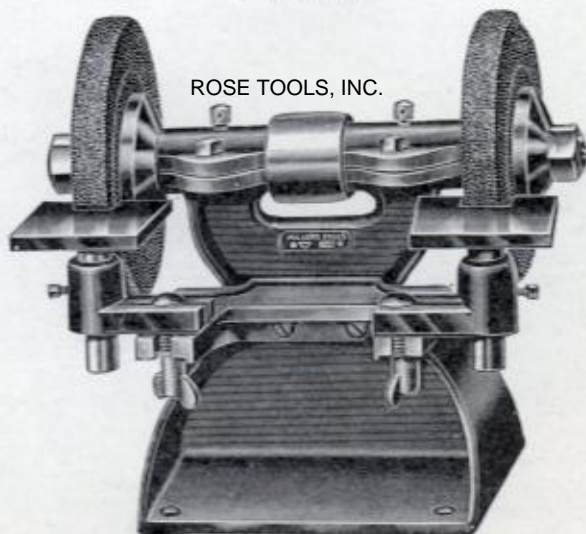

Same frame design as No. 257, but has the added features of table for holding work and grinding rests, both of which are adjustable and easily detached if desired.

This equipment adds much to the utility of the tool with but little extra cost.

Weight $32\frac{1}{2}$ lbs.

Code—Parts

Price each, \$16.00

(No emery wheels are furnished.)

Packed one in a box.



Carving Tool Sets

No. 1



A small, yet thoroughly practical set. Contains the following six tools, as illustrated: "V" tool, bevel chisel, curved gouge, straight chisel, "U" tool, straight gouge.

Forged steel blades with keen cutting edges. Stained hardwood handles, ferrules polished and nickel plated.

Packed in hardwood box with sliding cover. Length of tools 5½ inches.

Weight per set (with box), 9 oz.

Price per set, \$2.75

Code—Toast

Packed each box in a carton.

ROSE TOOLS, INC.

No. 2



This set differs from No. 1 only in the length of tools.

Length of tools 8½ inches.

Weight per set (with box), 1 lb.

Price per set, \$3.85

Code—Tobit

Packed each box in a carton.

Carving Tool Set

No. 3



ROSE TOOLS, INC.

A high quality set made especially for manual training school use. Contains the following twelve tools: "U" tool, veining tool, narrow bevel chisel, narrow chisel, small circular gouge, small flat gouge, bent chisel, "V" tool, curved gouge, large circular gouge, large flat gouge, wide chisel.

Clips hold each tool firmly in place.

Forged steel blades, with keen cutting edges. Strained hardwood handles. Polished and nickel plated ferrules. Packed in hinged hardwood box.

Length of tools, except matting tool, average $8\frac{1}{2}$ inches.

Weight per set (with box), $3\frac{5}{8}$ lbs.

Price per set, \$13.50

Code—*Toddy*

Packed each box in a carton.

Power Hack Saw

No. 89

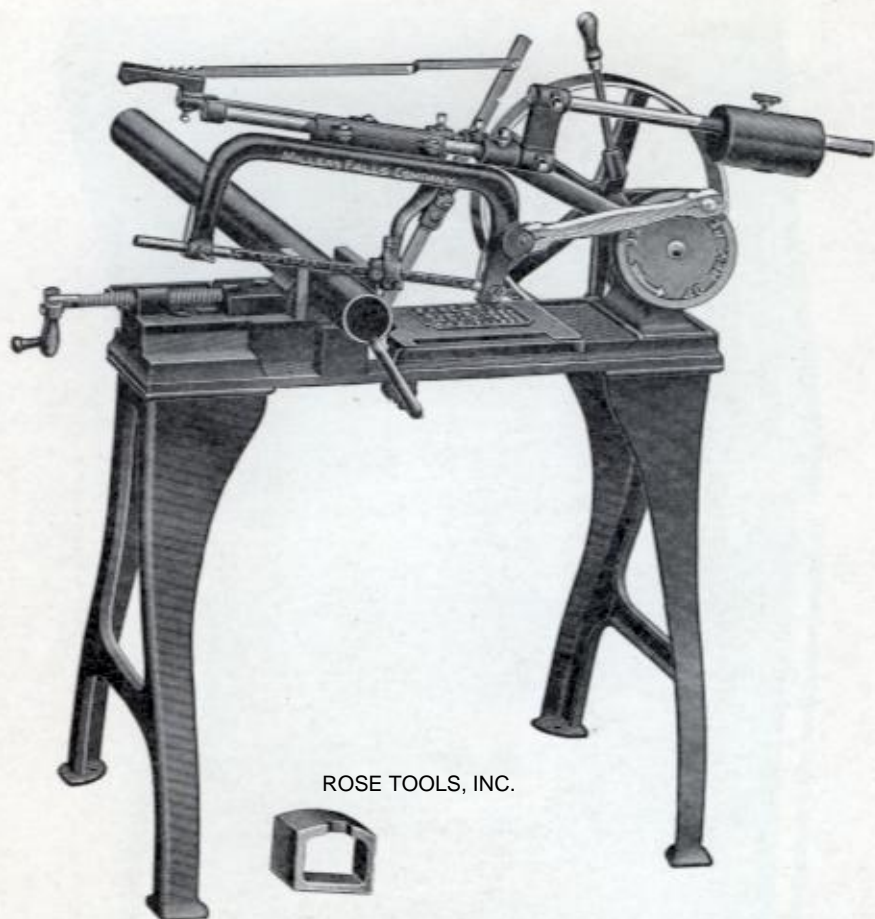

ROSE TOOLS, INC.

This machine, while simple in design and lighter than many power hack saws, is thoroughly efficient and practical.

Specifications

Gravity feed. Adjustable by weight on bar.

Direct drive. $5\frac{3}{4}$ inch stroke. Forty strokes per minute recommended.

One quarter H.P. required. Capacity, all shapes and sizes up to $4\frac{1}{2}$ inches.

Automatic stop. Height to top of bed, 28 inches. Size of pulley $13\frac{1}{2} \times 2\frac{1}{2}$ inches.

Takes 10, 11 and 12 inch blades. Six 12 inch blades furnished with machine.

Floor space, 18 x 30 inches.

Weight boxed, 222 lbs.; crated, 200 lbs.; net, 168 lbs.

Price \$60.00

Code—Tonka



Power Hack Saw

No. 91

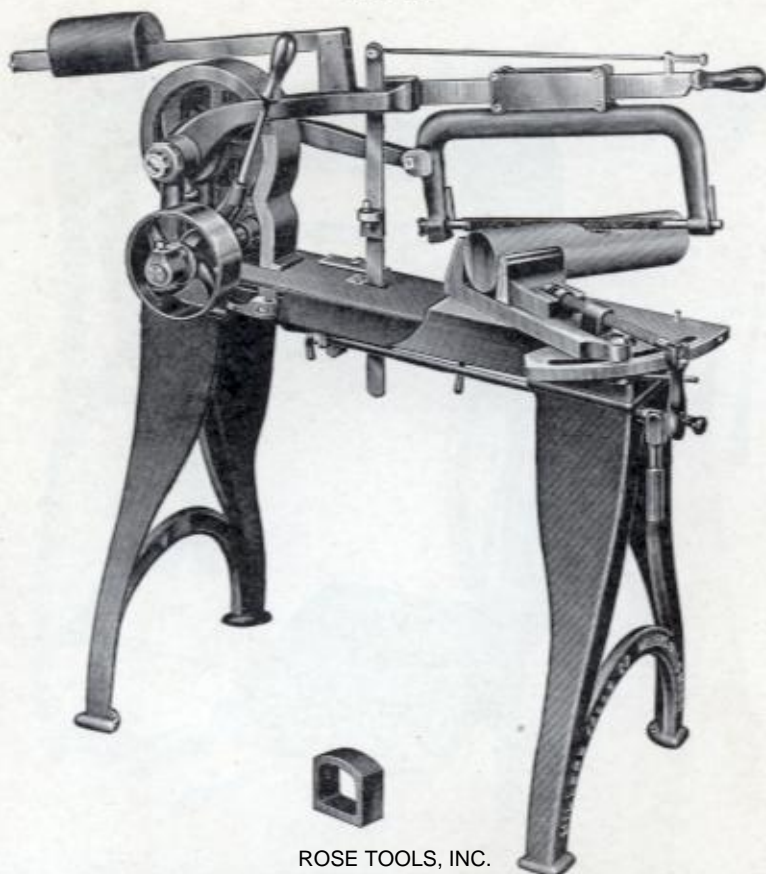

ROSE TOOLS, INC.

This machine is built on the same general lines as No. 89 shown preceding, but has several features which add to its serviceability.

The machine has gear drive, giving great steadiness to the stroke. By a patented device the saw frame is slightly lifted on the return stroke to prolong the life of the blade, and has a quick return movement. The speed of the back stroke is just twice that of the cutting stroke, resulting in a valuable saving of time. Action automatically stops when cut is completed.

An attachment is provided which, by lifting lever, holds the blade in suspension a trifle above the work. This permits the use of both hands in adjusting the work or measuring it, etc. There is a support on the bed on the cut-off side of the blade to prevent breaking blades when cut is nearly finished. In the head is an adjusting screw to take up any wear on the arm. A removable vise nut in the bed can be replaced in case of wear. The principal working parts of the machine are under the bed away from dust and dirt.

The swivel vise is particularly valuable in sawing material at an angle from 90° to 45°.

Specifications

Back geared 3 to 1.

Capacity 5 x 5 inches.

Adjusting screw in head for take up.

Stroke 5 3/4 inches.

Automatic stop.

Sixty strokes per minute recommended.

One-quarter H.P. required.

Height to top of bed 28 inches.

Pulley 6 inch diam. 2 inch face.

Takes 12 inch blades only.

Six 12 inch blades furnished with machine.

Floor space 20 x 46 inches.

Weight boxed, 305 lbs.; crated, 270 lbs.; net, 225 lbs.

Price \$92.00

Code—Tromp



Goodell Lathe

No. 317

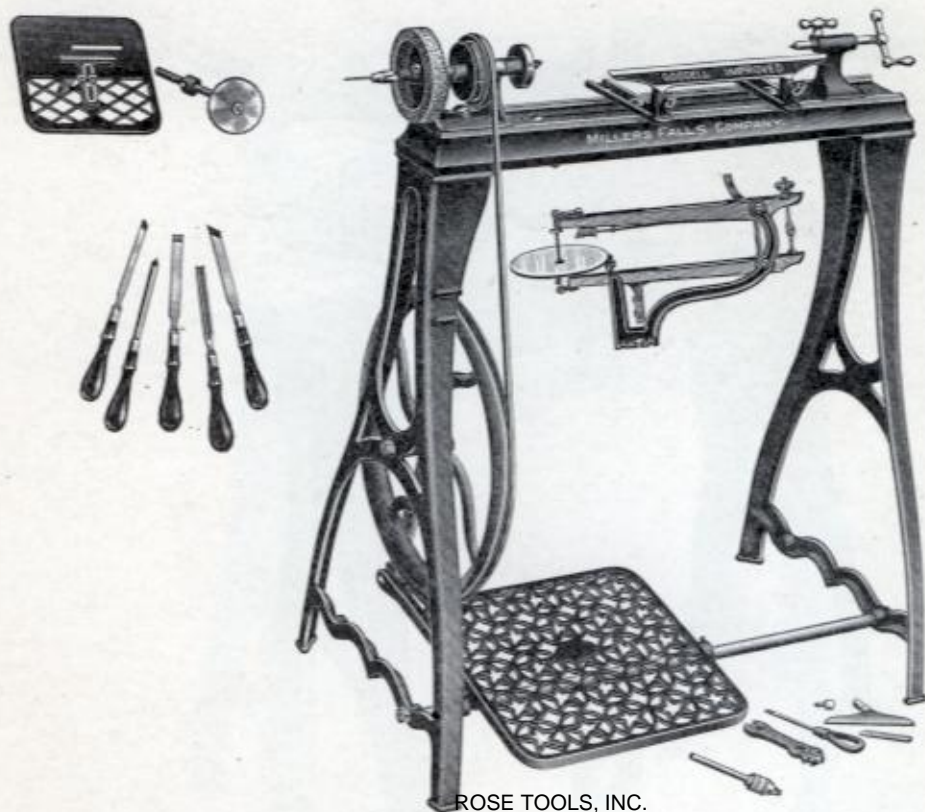

ROSE TOOLS, INC.

This lathe is intended for amateur work, and is an efficient machine for this purpose.

Specifications

Five inch swing, 14 inches between centers.

Two grooves on drive wheel cone pulley permit change of speed.

Head has 2 inch face plate and spur center and screw center for turning cups.

Tail stock has screw feed and can be clamped at any point.

Equipped with drill spindle with 3-jaw chuck, capacity 0-1/4 inch round shank drills, long and short tool rests; emery wheel 4 x 3/4 inch; five turning tools; wrench, and drill points.

No. 317 Lathe only.

No. 320 Lathe and Fret Saw Attachment.

No. 321 Lathe with Fret and Circular Saw Attachment.

No. 318 Fret Saw Attachment only.

No. 319 Circular saw attachment only.

No.	Weight Boxed	Weight Net	Price	Code
317	71 lbs.	50 lbs.	\$26.00	Vista
320	78 lbs.	57 lbs.	31.00	Vitis
321	81 lbs.	60 lbs.	32.50	Vivid
318	16 lbs.	7 lbs.	5.30	Vodka
319		3 lbs.	1.75	Volta

Knocked down and packed one machine in a wooden box.



REPAIR PARTS

ROSE TOOLS, INC.



Parts for Braces

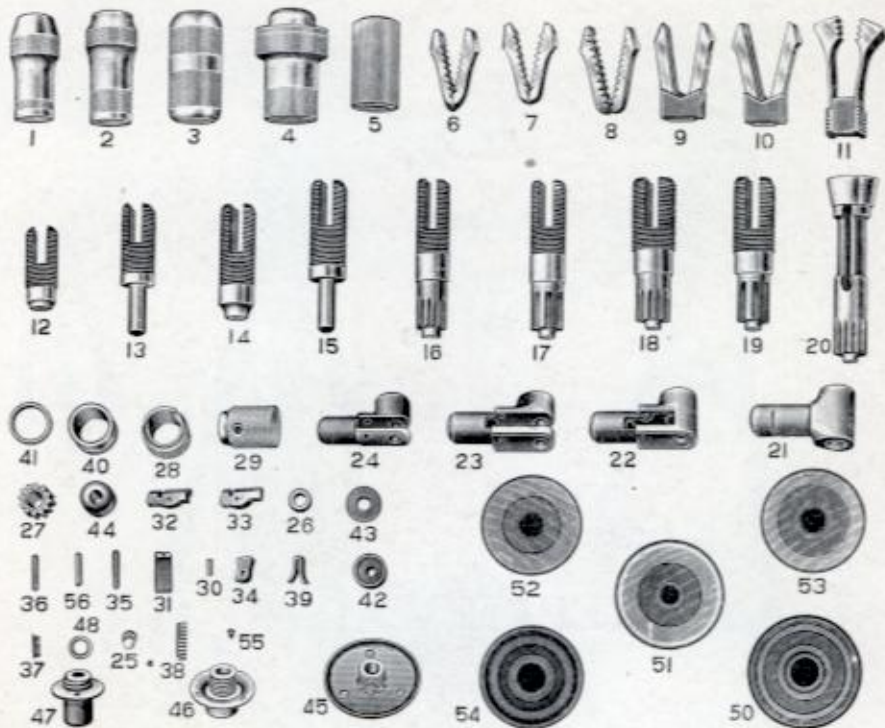

In ordering parts, the number of the brace for which they are wanted should be specified, as well as the number of the part. ROSE TOOLS, INC.

No.		Price Each
1	Shell for Nos. 141-143, 161-163	\$.40
1	Shell for Nos. 261-26335
1	Shell for Nos. 1661-1663.....	.45
2	Shell for Nos. 631-633, 601-603.....	.40
2	Shell for Nos. 21-23.....	.50
2	Shell for Nos. 30-34, 30A-34A, 131-133, 12-14.....	.60
2	Shell for Nos. 321-323, 1321-1324, 421-423, 221-223, 401-403.....	.55
3	Shell for Nos. 730-734, 8130-8133.....	.60
4	Shell for Nos. 870-872, 769-773, 7312	1.70
5	Shell for Nos. 1050-105460
6	Jaws for Nos. 141-143, 161-163, 631-633, 601-603, 261-263.....	.10
6	Jaws for Nos. 1661-1663, 401-40320
7	Jaws for Nos. 421-423.....	.20
8	Jaws for Nos. 30-34, 30A-34A, 131-133, 321-323, 1321-1324, 12-14, 21-23, 221-223.....	.50
9	Jaws for Nos. 730-734, 8130-8133.....	.65
10	Jaws for Nos. 870-872, 769-773, 731265
11	Jaws for Nos. 1050-1054.....	1.25
12	Chuck socket for Nos. 141-14315
13	Ratchet chuck socket for Nos. 161-163, 1661-1663, 261-263.....	.25
14	Chuck socket for Nos. 12-14, 21-23, 221-223, 401-403.....	.25
15	Ratchet chuck socket for Nos. 321-323, 1321-1324, 421-423, 631-633.....	.30



Parts for Braces—Continued

No.		Price Each
16	Ratchet chuck socket for Nos. 30-34, 30A-34A.....	\$.50
17	Ratchet chuck socket for Nos. 130-133.....	.50
18	Ratchet chuck socket for Nos. 769-773, 730-734, 7312.....	.55
19	Ratchet chuck socket for Nos. 8130-8133, 870-872.....	.55
20	Ratchet chuck socket for Nos. 1050-1054.....	1.50
21	Crooked socket for Nos. 131-133, 870-872, 8130-8133.....	.90
22	Crooked socket for Nos. 769-773, 730-734, 30-34, 30A-34A, 7312, 1050-1054.....	.70
23	Crooked socket for Nos. 321-323, 1321-1324, 421-423, 161-163, 1661-1663, 631-633.....	.70
24	Crooked socket for Nos. 261-263.....	.35
25	Ratchet chuck socket screw for Nos. 870-872, 769-773, 730-734, 8130-8133, 30-34, 30A-34A, 130-133, 1050-1054, 7312.....	.10
26	Ratchet chuck socket washer for braces as under No. 25.....	.10
27	Ratchet gear for braces as under No. 23 and No. 24.....	.10
28	Boxed ratchet rings for Nos. 769-773, 730-734, 30-34, 30A-34A, 321-323, 1321-1324, 421-423, 161-163, 1661-1663, 631-633, 1050-1054, 7312.....	.20
29	Enclosed ratchet rings (complete with cam) for Nos. 870-872, 130-133, 8130-8133.....	.25
30	Enclosed ratchet ring screw for braces as under No. 29.....	.10
31	Enclosed ratchet pawls and pins (set of two) for Nos. 870-872, 8130-8133, 130-133.....	.20
32	Boxed ratchet pawls and pins (set of two) for Nos. 769-773, 730-734, 30-34, 30A-34A, 1050-1054, 7312.....	.25
33	Ratchet pawls (set of two) for Nos. 321-323, 1321-1324, 421-423, 1661-1663, 161-163, 631-633.....	.25
34	Ratchet pawls (set of two) for Nos. 261-263.....	.15
35	Ratchet pawl pins for all Nos. except 261-263.....	.10
36	Ratchet pawl pins for Nos. 261-263.....	.10
37	Enclosed ratchet pawl springs (set of one) for Nos. 870-872, 130-133, 8130-8133.....	.10
38	Ratchet pawl spring (set of one) for Nos. 769-773, 730-734, 30-34, 30A-34A, 321-323, 1321-1324, 421-423, 161-163, 1661-1663, 631-633, 1050-1054, 7312.....	.10
39	Ratchet pawl spring (set of one) for Nos. 261-263.....	.10
40	Socket ring washer for braces Nos. 1050-1054.....	.20
41	Socket ring washer for braces Nos. 870-872, 769-773, 730-734, 8130-8133, 30-34, 30A-34A, 130-133, 7312.....	.10
42	Ball race for Nos. 870-872, 769-773, 730-734, 8130-8133, 130-133, 1050-1054, 30-34, 30A-34A, 12-14, 321-323.....	.10
43	Ball bearing washer for Nos. 870-872, 769-773, 730-734, 8130-8133, 1050-1054, 30-34, 30A-34A, 130-133, 12-14, 21-23, 221-223, 321-323, 1321- 1324.....	.10
44	Anti-friction collar for Nos. 1321-1324, 21-23, 221-223.....	.10
45	Quill for Nos. 870-872, 769-773, 30A-34A, 1050-1054, 1321-1324.....	.45
46	Quill for Nos. 730-734, 8130-8133, 30-34, 130-133, 321-323, 12-14, 21-23, 221-223.....	.35
47	Quill for Nos. 421-423, 161-163, 1661-1663, 631-633, 261-263, 141-143, 401-403, 601-603.....	.20
48	Quill washer for Nos. under 46 and No. 7312.....	.10
49	Quill washer for Nos. under 47 (not illustrated).....	.10
50	Head for braces Nos. 870-872, 769-773, 30A-34A, 1050-1054.....	.50
51	Head for braces Nos. 730-734, 30-34, 8130-8133, 130-133, 12-14.....	.50
52	Head for braces Nos. 321-323, 221-223, 21-23.....	.25
53	Head for braces Nos. 421-423, 161-163, 1661-1663, 631-633, 261-263, 141-143, 401-403, 601-603.....	.20
54	Head for braces Nos. 1321-1324.....	.25
55	Stop screw for Nos. 1050-1054 shell.....	.10
56	Ratchet gear pin for braces as under Nos. 23 and 24.....	.10

ROSE TOOLS, INC.

MILLERS FALLS COMPANY



Parts for Bench Drills Nos. 210 and 216

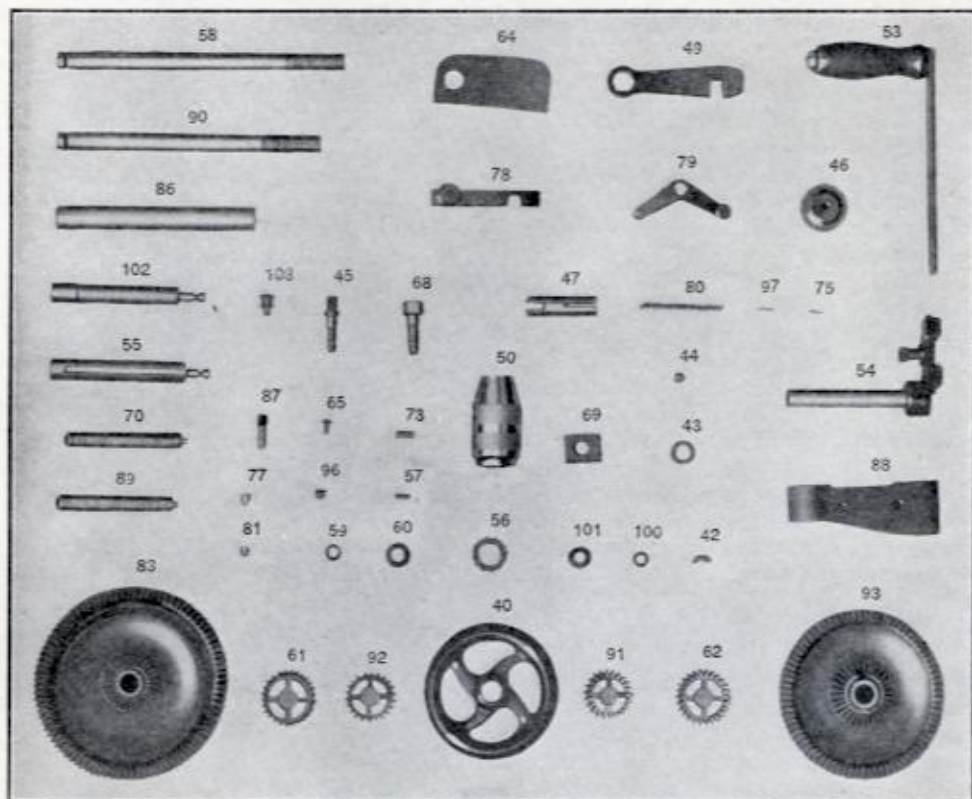

Part No.	Used on	Name of Part	Price	Part No.	Used on	Name of Part	Price
40	216-210	Feed wheel		216	216	Shifter, complete	\$1.00
41	216-210	Feed wheel pin (Br. long dog)	.10	72	216	Shifter barrel (two speed)	
42	216-210	Spline key	.10	73	216	Shifter dog (two speed)	
43	216-210	Key collar	.15	74	216	Shifter cam	
44	216-210	Key collar screw	.10	75	216	Shifter dog spring (No. 87 Br. Dr.)	
45	216-210	Table bracket clamp screw (No. 210 arm)	.10	76	216	Shifter sleeve (knurled)	
46	216-210	Bench clamp screw washer	.10	77	216-210	Spline pin	
47	216-210	Bench clamp screw handle	.20	78	216	Feed bar, complete	
48	216-210	Bench clamp screw handle pin	.10	79	216	Cam lever, complete	
49	216-210	Wrench	.10	80	216	Cam lever spring	
50	216-210	Chuck No. 7, nicked	2.60	81	216	Cam lever spring plug	
51	216-210	Shifter Dog pin (No. 99 Br. Dr.)	.10	82	216	Steel ball bearings, 3/32 in., per doz.	
52	216-210	Gear pin (No. 12 Pinion)	.10	83	216	Large gear	1.25
53	216-210	Flat crank handle, complete	.40	84	210	Frame	7.00
54	216-210	Crank casting, complete (with large gear shaft)	.55	85	210	Table	1.50
55	216	Feed screw	.60	86	210	Table post	.40
56	216	Feed gear	.10	87	210	Table post set screw (Bor.M.Top Cap)	
57	216	Feed gear spline gib	.10	88	210	Table arm	.80
58	216	Spindle	.55	89	210	Bench clamp screw	
59	216	Small ball race	.10	90	210	Spindle	.40
60	216	Large ball race	.10	91	210	Fast pinion	
61	216	Slow pinion	.25	92	210	Slow pinion	
62	216	Fast pinion	.30	93	210	Large gear	
63	216	Frame	11.05	94	210	Shifter, complete	1.25
64	216	Frame cap	.10	95	210	Shifter barrel	
65	216	Frame cap screw (No. 102 Spk. Pt.)	.10	96	210	Shifter dogs (No. 99 Br. Dr.)	
66	216	Table	2.30	97	210	Shifter dog spring (No. 99 Br. Dr.)	
67	216	Table bracket	1.30	98	210	Shifter cam	
68	216	Table bracket bolt	.10	99	210	Shifter sleeve (knurled)	
69	216	Table bracket bolt nut	.10	100	210	Small bearing washer	
70	216	Bench clamp screw	.15	101	210	Large bearing washer	
				102	210	Feed screw	
				103	216	Cam lever screw	

Note—Please order by drill number as well as part number in order to avoid possible chance of error. Those parts not illustrated are easily identified by descriptive list.



Parts for Bench Drills

Nos. 20 and 21

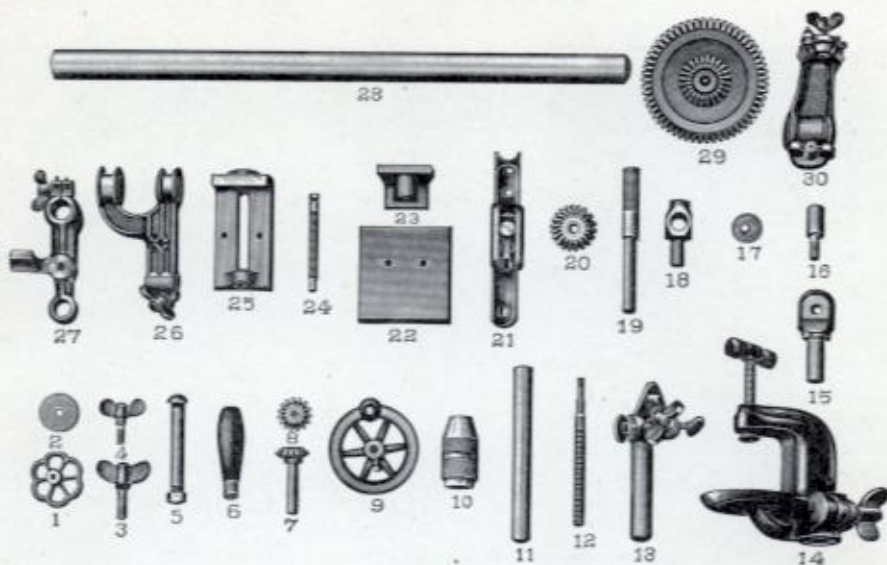

1	Vise wheel.....	\$.10
2	Fiber washer.....	.10
3	Bench clamp binder screw.....	.10
4	Frame thumb screw and vise arm thumb screw.....	.20
5	Crank handle bolt and nut.....	.20
6	Crank handle.....	.35
7	Arbor and gear.....	.20
8	Spindle gear.....	.15
9	Feed wheel, complete.....	.55
10	Chuck.....	2.60
11	No. 21 attachment frame.....	1.30
12	Feed screw.....	.60
13	No. 20 attachment, complete.....	1.90
14	Bench clamp, complete.....	1.50
15	Swivel.....	.80
16	Vise swivel screw.....	.10
17	No. 21 attachment gear screw.....	.15
18	No. 21 attachment gear stud.....	.45
19	No. 21 attachment spindle.....	.50
20	No. 21 attachment pinion.....	.50
21	No. 21 attachment crank, complete.....	1.05
22	Vise table.....	.50
23	Vise short jaw.....	.30
24	Vise feed screw.....	.10
25	Vise long jaw.....	.80
26	Lower frame, complete.....	.50
27	Upper frame, complete.....	.55
28	Standard.....	.90
29	No. 21 attachment large gear.....	.90
30	Vise arm, complete.....	1.30

ROSE TOOLS, INC.

Please order by drill number as well as part number. It will avoid possible chance of error.



Parts for Boring Machine

No. 144

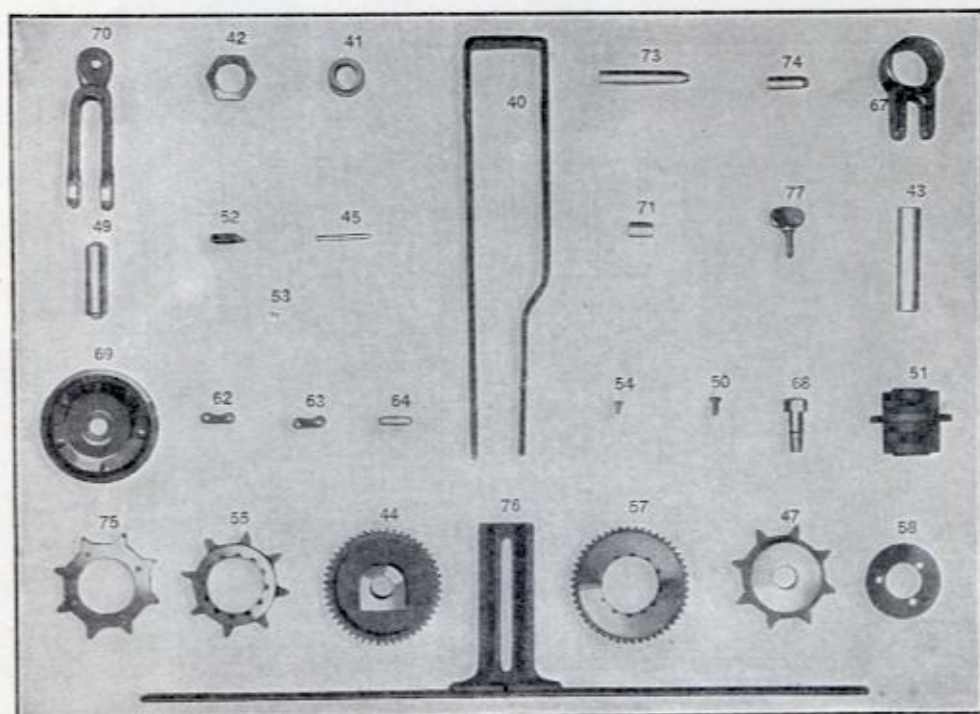

ROSE TOOLS, INC.

Ordering by number will avoid possible error and save unnecessary correspondence.

No.	Name of Part	Price	No.	Name of Part	Price
40	Frame	\$3.75	61	Long Chain, 61 in.	\$2.25
41	Frame Bearing Bushing	.25	62	Side Link	.10
42	Frame Bearing Bushing Nut	.20	63	Connecting Link	.10
43	Frame Spindle	.25	64	Connecting Link Lock	.10
44	Spindle Gear	.75	65	Large Tubes, 1 1/4 x 18 ga. x 6 ft.	3.75
45	Gear Taper Pin	.10	66	Small Tubes, 1 1/8 x 18 ga. x 6 ft.	3.75
47	Spindle Sprocket Complete	1.75	67	Large Tube Clamp	.40
48	Spindle Sprocket Bushing Pin	.10	68	Large Tube Clamp Screw	.10
49	Idle Spindle	.20	69	Shive Pulley	.45
50	Idle Spindle Screw	.15	70	Clevis	.30
51	Idle Spindle Ratchet Sleeve	3.15	71	Pulley Bushing	.15
52	Idle Spindle Ratchet Dog	.25	72	Pulley Pin	.10
53	Idle Spindle Ratchet Dog Spring	.15	73	Long Stop Screw	.10
54	Idle Spindle Sleeve Sprocket Screw	.10	74	Short Stop Screw	.10
55	Idle Spindle Collar Sprocket, complete	1.50	75	Idle Spindle Ratchet Sleeve Sprocket	.75
57	Idle Spindle Spur Gear	.95	76	Below Boring Attachment, complete	1.00
58	Idle Spindle Washer	.15	77	Below Boring Attachment Thumb Screw	.15
59	Short Chain, 14 in.	.45	78	Wood Handles, per pair	1.00
60	Long Chain, 96 in.	3.15			

Parts for Boring Machine No. 145

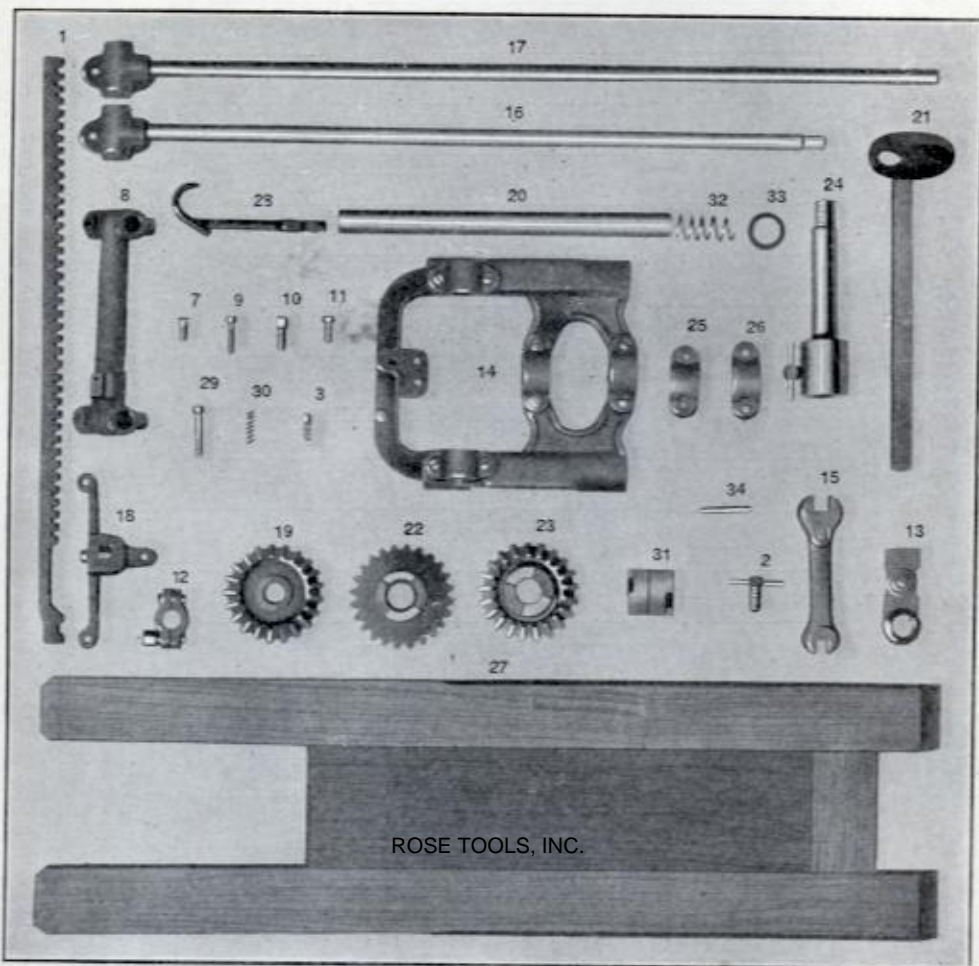

ROSE TOOLS, INC.

Ordering by number will avoid possible error and save unnecessary correspondence.

No.	Name of Part	Price	No.	Name of Part	Price
1	Rack	\$.90	19	Spindle Gear	\$.65
2	Chuck Set Screw	.10	20	Arbor	.40
3	Short Rod Set Screw	.10	21	Flat Handle, complete	.60
7	Arbor Cap Screw or Spider Screw	.10	22	Rack Gear	.75
8	Top Cap	1.05	23	Arbor Gear	.75
9	Hook Screw (short) or Rack Screw	.10	24	Chuck Spindle, complete	1.25
10	Long Rod Set Screw	.10	25	Arbor Cap	.10
11	Spindle Cap Screw	.10	26	Spindle Cap	.10
12	Stop, Complete	.30	27	Table	2.20
13	Crank Casting, complete	.30	28	Hook	.20
14	Frame	3.45	29	Hook Screw (long)	.10
15	Wrench	.25	30	Hook Spring	.10
16	Short Rod, complete	1.15	31	Clutch	.25
17	Long Rod, complete	1.20	32	Gear Spring	.10
18	Spider, complete	.40	33	Gear Washer	.10
			34	Taper Pin	.10

MILLERS FALLS COMPANY



PARTS FOR HAND DRILLS AND BREAST DRILLS

BREAST DRILLS

HAND DRILLS										BREAST DRILLS																					
No.	Main Handle, each	Stationary Side Handle, each	Crank and Hand-die, per set	Chuck complete, each	Jaws, per set	Large Gear, each	Small Gear, each	Main Frame, each	Cap only for hand-die	No.	Chuck complete, each	Chuck Jaws	Chuck Shell, each	Chuck Socket, each	Frame, each	Large Gear, each	Small Gear, each	Crank only, each	Crank Handle, Wood only, ea.	Bolt and Nut for Crk H'dl, per set	Stationary Side Handle, each	Breastplate, each	Auxiliary Breast-plate, each	Gear Screw, each	Crank Screw, each	Long Ball Cup, each	Short Ball Cup, each	Spindle, each	Frame Stem, each	Joint Screw, each	Level, each
1	.65	.25	.25	1.50	.60	.50	.10	.70	.25	10	1.20	.80	.70	1.40	1.10	1.00	.50	k.90	.25	.20	.35	.40	.00	.15	.15	.15	.10	.00	.00	.35	
01	.25	.25	.25	1.50	.60	.50	.10	.70	.25	12	1.70	.80	.70	1.40	1.40	1.00	.40	.20	.20	.15	.20	.35	.00	.15	.15	.15	.15	.00	.00	.35	
2	1.00	.25	.50	2.00	.70	.75	.10	.90	.30	12 ^a	1.65	.60	.65	1.40	1.40	1.00	.40	.20	.20	.15	.20	.35	.00	.15	.15	.15	.15	.00	.00	.35	
2b	.35	.25	.50	2.00	.70	.75	.10	.90	.30	13	2.00	.80	.70	1.40	1.00	1.00	.30	k.90	.20	.15	.20	.35	.00	.15	.15	.20	.00	.00	.35		
2d	1.00	.25	.50	2.00	.70	.75	.10	.90	.30	15	1.90	.80	.70	1.40	1.30	1.10	.40	.15	.25	.20	.20	.35	.00	.15	.15	.15	.15	.00	.00	.35	
3	.55	.25	.20	1.50	.60	.40	.10	.30	.19	19	1.40	.60	.55	.70	m.90	1.00	.40	.15	.20	.10	.10	.35	.00	.15	.15	.15	.10	.40	.30	.00	
4	.00	.00	.10	1.00	.10	.20	.15	.25	.29	29	2.25	.60	.70	.30	m.90	1.00	.40	.15	.20	.10	.10	.35	.00	.15	.15	.15	.10	.40	.30	.00	
4p	.00	.00	.10	1.00	.10	.20	.15	.25	.29	87	2.00	.80	.70	.50	1.30	1.10	.70	.30	.20	.20	.50	.20	.35	.60	.15	.15	.15	.10	.15	.15	.00
5	.65	.25	.20	1.50	.60	.60	.10	.65	.25	97	2.50	.90	.80	.30	1.30	1.10	.70	.30	.20	.20	.50	.20	.35	.60	.15	.15	.15	.10	.15	.15	.00
05	.25	.25	.20	1.50	.60	.60	.10	.65	.25	99	1.90	.75	.70	.40	1.30	1.00	.25	.10	.20	.20	.50	.20	.30	.60	.15	.15	.15	.10	.15	.15	.00
7	.25	.25	.15	2.00	.70	.55	.15	.75	.25	100	2.50	.70	.80	.30	1.30	1.00	.25	.10	.20	.20	.50	.20	.30	.60	.15	.15	.15	.10	.15	.15	.00
85	.20	.00	.20	1.05	.40	.25	.10	.65	.112	112	1.50	.60	.60	.80	j.45	.25	.25	.10	.20	.20	.10	.20	.35	.60	.15	.15	.15	.10	.15	.15	.00
104	.40	.00	.20	1.50	.40	.35	.10	.50	.20	118	2.50	.70	.80	.30	1.40	1.10	.40	.10	.20	.15	.20	.35	.60	.15	.15	.15	.10	.10	.10	.15	.00
303	.40	.25	.20	1.50	.60	.40	.10	.25	.15	208	2.50	.70	.80	.30	1.30	1.05	.25	g.10	.20	.50	.20	.35	.60	.15	.15	.15	.10	.10	.10	.15	.00
313	.30	.00	.20	1.50	.60	.40	.10	.30	.212	212	1.80	.70	.30	.30	.80	j.45	.25	.10	.20	.10	.20	.35	.60	.15	.15	.15	.10	.10	.15	.15	.00
315	.40	.25	.15	1.50	.40	.65	.10	.30	.15	293	1.90	.70	.30	.30	.80	j.45	.25	.10	.20	.10	.20	.35	.60	.15	.15	.15	.10	.10	.15	.15	.00
343	.50	.25	.20	1.50	.60	.60	.10	.30	.10	2100	2.40	.70	.80	.30	1.20	1.00	.25	.10	.20	.10	.20	.35	.60	.15	.15	.15	.10	.10	.15	.15	.00
980	.80	.25	.25	2.00	.70	.80	.15	1.20	.00	.00	.00	.00	.00	.00	.00	.00	.00	.00	.00	.00	.00	.00	.00	.00	.00	.00	.00	.00	.00	.00	.00
1980	.80	.25	.15	1.00	.70	.80	.15	1.20	.00	.00	.00	.00	.00	.00	.00	.00	.00	.00	.00	.00	.00	.00	.00	.00	.00	.00	.00	.00	.00	.00	.00

a—includes ratchet mechanism; b—includes two parts; c—per pair; d—per set of three jaws; e—includes cone bearing; f—includes two gear bearings and speed shifter; g—includes crank bearing and ratchet stud; h—includes small gear and pin for same; i—has ratchet plate and two pins; j—includes gear arbor; k—crank complete with all screws; m—cast-iron frame only.

Note—When ordering parts please specify the number of the Drill, and the name of part wanted. Attention to this detail will avoid any chance of error.



Parts for Millers Falls No. 387 Fret Saw

Arm Casting.....	\$0.70	Drive Wheel.....	\$3.35
Arm Casting Adjustment, upper arm....	.10	Drive Pulley.....	.25
Arm Casting Adjustment, lower arm....	.10	Drive Wheel Arbor, complete.....	.15
Arms, per pair.....	.70	Emery Wheel.....	.50
Arm Pin.....	.10	Emery Wheel Arbor, complete.....	.30
Arm Bolt, 1 x 1¼ in. Round Head Car, plated.....	.10	Front Leg.....	2.65
Back Leg.....	1.60	Locking Bolt.....	.10
Frame to which Arm Casting is attached	1.20	Pitman, Short.....	.10
Balance Wheel.....	.85	Pitman Yoke Castings.....	.10
Brace.....	.35	Pitman Bolt, R H Stove 13/16 x 3/16 in.	.10
Brace Bolt, R H Stove 1¼ x 3/16 in....	.10	Pitman, long.....	.10
Blower, complete.....	.25	Saw Guide.....	.10
Blower Lever.....	.10	Saw Guide Screw, 3/8 in. No. 8 Machine Screw.....	.10
Belt.....	.70	Saw Table, Japanned.....	1.05
Crank and Drill Spindle.....	.30	Saw Table Bolt, 1 x ¼ in. R H Carriage.	.10
Crank Screw.....	.10	Stretcher Rod, complete.....	.20
Clamps, upper and lower, complete.....	.60	Treadle.....	1.35
Clamp Bolts, 1 3/8 x 3/16 in. R H Stove..	.10	Treadle Caps, per pair.....	.10
Drill Spindle, wing nut.....	.15	Treadle Cap Screws, ¼ x 3/8 in. Blind Screws.....	.10
Drills, per dozen.....	.50	Treadle Bolt, 1¼ x 7/32 in. R H Stove..	.10

Parts for Goodell Lathe

No. 317

Lathe Bed.....	2.60	Attachment Arm Casting.....	1.60
Legs, each (2).....	2.60	Arms, per pair.....	.70
Treadles.....	1.65	Table.....	.95
Treadle Rod.....	.50	Stretcher.....	.10
Treadle Caps, each (2).....	.30	Clamps, per pair.....	.60
Driving Wheel.....	3.00	Bolts.....	.10
Driving Wheel Bolt.....	.10	Turning Tools (5).....	3.50
Emery Wheel.....	.50	Arm Bolts and Nuts.....	.10
Headstock.....	.65	Belt.....	.75
Headstock Spindle and Face Plate.....	.60	Drills, per dozen.....	.10
Headstock Spindle Cone Pulley.....	.60	Pitman, Long.....	.10
Tailstock.....	.65	Pitman, Short.....	.10
Tailstock Spindle and Crank.....	.30	Pitman Screws.....	.10
Tailstock Spindle Binder.....	.35	Screw Driver.....	.10
Long Rest.....	.20	Blower.....	.30
Short Rest.....	.10	Table Bolt.....	.10
Rest Sockets, each (2).....	.25	Wrench.....	.15
Spur Center.....	.10	Saw Guide (new pattern).....	.10
Screw Center for Cups.....	.10	Arm Spring.....	.10
Millers Falls Chucks.....	2.50	Winged Drill Nut.....	.15

Parts for Langdon Acme Mitre Boxes

Nos. 68-75

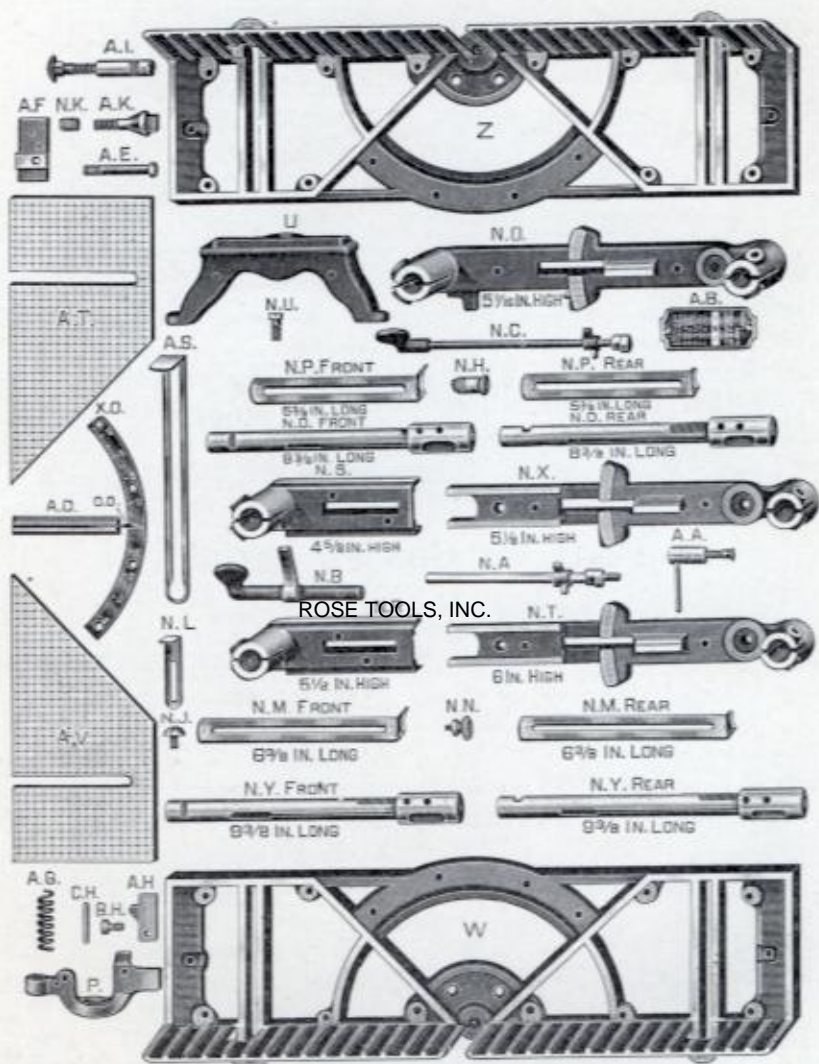

ROSE TOOLS, INC.



Parts for Langdon Acme Mitre Boxes

(Nos. 68-75)

AA	Binder	for sizes 2 and 2½ box	\$.10
AB	Index Plate	" all sizes of boxes	
AD	Gib	" " " "	.25
AE	Gib Screw	" " " "	.30
AF	Binding Strap	" " " "	.10
AG	Spring	" " " "	.15
AH	Stop Lever Strap	" " " "	.10
AI	Stock Rest	" " " "	.10
AK	King Bolt	" " " "	.30
AS	Length Gauge	" " " "	.15
AT	Right Hand Bottom Board	" " " "	.20
AV	Left Hand Bottom Board	" " " "	.75
BH	Stop Lever Strap Screw	" " " "	.75
CH	Stop Lever Pin	" " " "	.10
NA	Stop Lever Rod	" sizes 2 and 2½ box	.10
NB	Thumb Lever	" " " " " "	.35
NC	Thumb Stop Lever	" size 1 box	.25
ND	Saw Guide Front	" sizes 1 and 2 box	.50
ND	Saw Guide Rear	" " " " " "	.90
NH	Elevator	" all sizes of boxes	.90
NJ	Guide Stop Screw	" " " "	.50
NK	King Bolt Stop Screw	" " " "	.10
NL	Guide Stop	" " " "	.10
NM	Stop Gauge Front and Rear	" size 2½ box	.10
NN	Stop Gauge Thumb Screw	" all sizes of boxes	.15
NO	Swinging Lever	" size 1 box	2.60
NP	Stop Gauge Front and Rear	" sizes 1 and 2 box	.10
NR	Sliding Front Post	" size 2½ box	1.20
NS	Sliding Front Post	" " 2 box	1.10
NT	Swinging Lever	" " 2½ box	2.45
NU	Leg Screw	" all sizes of boxes	.10
NX	Swinging Lever	" size 2 box	2.45
NY	Saw Guide Front	" " 2½ box	.95
NY	Saw Guide Rear	" " " "	.95
OO	Indicator	" all sizes or boxes	.10
P	Stop Lever	" " " "	.25
U	Leg	" " " "	.35
W	Bed and Back	" size 2½ box	6.15
XO	Graduated Arc	" all sizes of boxes	.55
Z	Bed and Back	" sizes 1 and 2 box	6.15

ROSE TOOLS, INC.

Parts NO, P, NR, NS, NT, U, W, NX and Z have corresponding letters cast in them, so, if in doubt, reference may be made to the castings.



Parts for New Langdon Improved Nos. 29, 32, 33 and 34 and New Langdon Mitre Boxes Nos. 17, 23 and 25

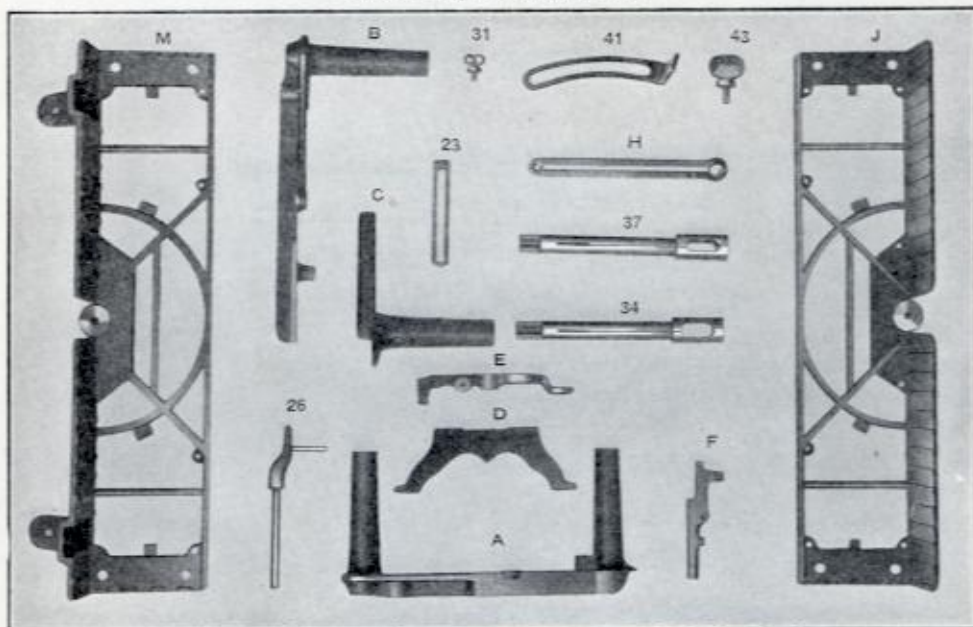

Part No.	New Langdon	Used on New Langdon Imp.	Name of Part	Price
A	Size 1	Size 1	Swinging Lever.....	\$2.10
B	" 2	" 2	Swinging Lever.....	1.20
C	" 2	" 2	Sliding Post.....	1.05
D	" 1-2-2½	" 1-2-2½	Legs.....	.25
E	" 1	" 1	Stop Lever.....	.20
F	" 2-2½	" 2-2½	Stop Lever.....	.25
H	" 1-2-2½	" 1-2-2½	Gib.....	.45
K	" 2½	" 2½	Sliding Post.....	1.15
J	" 1-2	"	Bed and Back.....	5.20
Y	" 2½	"	Bed and Back.....	5.20
M	"	" 1-2	Bed and Back.....	5.20
N	"	" 2½	Bed and Back.....	5.20
L	" 2½	" 2½	Swinging Lever.....	1.75
23	" 1-2-2½	" 1-2-2½	Stop Gauge—Front.....	.10
26	" 2-2½	" 2-2½	Thumb Lever, complete.....	.25
31	" 1-2-2½	" 1-2-2½	Thumb Screw.....	.10
32	" 1-2	" 1-2	Stop Gauge—Rear.....	.10
33	" 2½	" 2½	Stop Gauge—Rear.....	.10
34	" 1	" 1	Front Guide.....	.85
35	" 2	" 2	Front Guide.....	.85
36	" 2½	" 2½	Front Guide.....	.85
37	" 1-2	" 1-2	Rear Guide.....	.85
38	" 2½	" 2½	Rear Guide.....	.85
39	" 1-2	" 1-2	Bottom Boards (Right or Left).....	.25
40	" 2½	" 2½	Bottom Boards (Right or Left).....	.25
41	"	" 1-2	Circular Arms (Right or Left).....	.25
42	"	" 2½	Circular Arms (Right or Left).....	.25
43	"	" 1-2-2½	Circular Arm Thumb Screws.....	.15



Parts for Old Style Langdon Acme Mitre Box

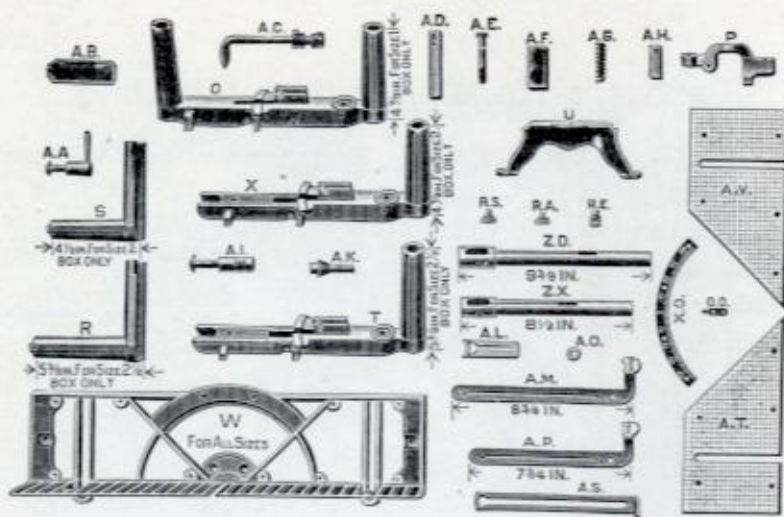

Part No.	Name of Part	Price, each
AA	Binder	for sizes 2 and 2½ box..... \$0.10
AB	Index Plate	" all sizes of boxes..... .25
AC	Thumb Stop Lever	" " " "..... .50
AD	Gib	" " " "..... .30
AE	Gib Screw	" " " "..... .10
AF	Binding Strap	" " " "..... .15
AG	Spring	" " " "..... .10
AH	Stop Lever Strap	" " " "..... .10
AI	Stock Rest	" " " "..... .30
AK	King Bolt	" " " "..... .15
AL	Guide Stop	" " " "..... .10
AM	Elevator Bar	" size 2 1/2 box..... .30
AO	Washer	" all sizes of boxes..... .10
AP	Elevator Bar	" sizes 1 and 2 box..... .30
AS	Length Gauge	" all sizes of boxes..... .20
AT	Right Hand Bottom Board	" " " "..... .75
AV	Left Hand Bottom Board	" " " "..... .75
O	Swinging Lever	" size 1 box..... 2.60
OO	Indicator	" all sizes of boxes..... .10
P	Stop Lever	" " " "..... .25
R	Sliding Front Post	" size 2½ box..... 1.15
RA	Guide Stop Screw—Rear	" all sizes of boxes..... .10
RE	Elevator Stop Screw	" " " "..... .10
RS	Guide Stop Screw—Front	" sizes 2 and 2½ box..... .10
S	Sliding Front Post	" size 2 box..... 1.10
T	Swinging Lever	" size 2½ box..... 2.45
U	Leg	" all sizes of boxes..... .35
W	Bed and Back	" size 2½ box..... 6.15
X	Swinging Lever	" size 2 box..... 2.45
XO	Graduated Arc	" all sizes of boxes..... .50
ZD	Saw Guide	" size 2½ box..... .90
ZX	Saw Guide	" sizes 1 and 2 box..... .90
Z	Bed and Back	" " " "..... 6.25

ROSE TOOLS, INC.

Parts O, P, R, S, T, U, W and X, have corresponding letters cast in them, so, if in doubt, reference may be made to the castings.



Parts for No. 145 Automobile Jack

Handle, complete.....	\$1.80	Worm Gear, without ball race and ball bearings.....	.35
Handle, Hexagon Rod.....	.60	Worm Gear, ball race and ball bearings for Gear, without pinion and pinion retaining ring.....	.20
Handle, Adjustable Cross Arm.....	.20	Gear, pinion and pinion retaining ring for Lift Screw, with Lift Screw Washer.....	.40
Handle, special piping with connections and stops on either end.....	1.20	Cover Plate, with cover plate screws.....	.20
Base, without Thumb Screw.....	.90		
Base, Thumb Screw for.....	.10		

Parts for No. 160 Truck Jack

Barrel.....	\$3.60	Ratchet Collar Retaining Ring.....	.20
Barrel Base Plate.....	.10	Ratchet Nut.....	.85
Barrel Base Plate Retaining Ring.....	.10	Ball Race, Per Pair.....	.45
Lift Screw, with Stop Pin.....	1.60	Ball Bearings, Per Set.....	.10
Lift Screw Cap.....	.40	Ball Bearing Separator.....	.10
Ratchet Collar.....	1.20	Ratchet Pawl, with Spring, Pin and Knob.....	.50
		Operating Lever.....	.60

Parts for No. 165 Truck Jack

Barrel.....	\$2.20	Ratchet Collar Retaining Ring.....	.20
Barrel Base Plate.....	.10	Ratchet Nut.....	.60
Barrel Base Plate Retaining Ring.....	.10	Ball Race, Per Pair.....	.40
Lift Screw, with Stop Pin.....	1.10	Ball Bearings, Per Set.....	.10
Lift Screw Cap.....	.40	Ball Bearing Separator.....	.10
Ratchet Collar.....	.80	Ratchet Pawl, with Spring, Knob and Pin.....	.50
		Operating Lever.....	.60

Parts for Power Hack Saws

No. 89

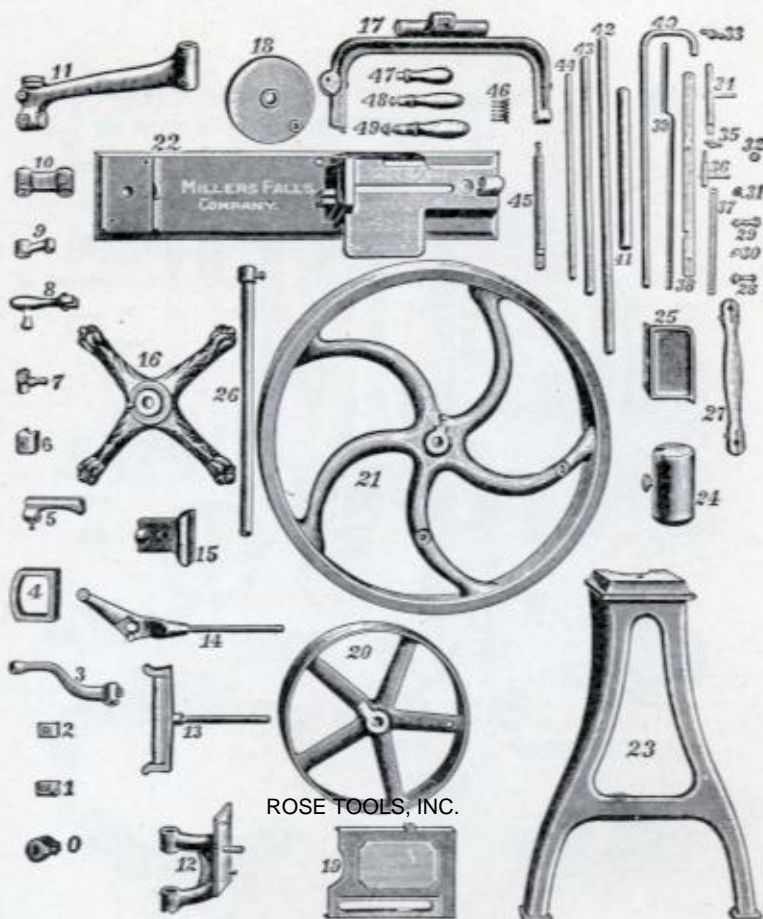

ROSE TOOLS, INC.

No.	No.	No.			
0 Clutch Collar.....	\$0.40	17 Frame.....	\$3.10	34 Long Stud.....	\$0.30
1 Elevator Stop.....	.10	18 Face Plate.....	1.40	35 Short Stud Nut.....	.25
2 Frame Clamp.....	.15	19 Sliding Frame.....	.90	36 Short Stud.....	.10
3 Long Guide.....	.50	20 Pulley.....	5.15	37 Short Strap.....	.20
4 Loose Vise Jaw.....	.90	21 Hand Wheel.....	20.25	38 Elevator Bar.....	.20
5 Lift Handle.....	.30	22 Bed.....	10.20	39 Long Strap.....	.20
6 Gauge Clamp.....	.10	23 Leg.....	7.00	40 Gauge Rod.....	.40
7 Short Guide.....	.40	24 Weight.....	2.80	41 Arbor.....	.45
8 Vise Wrench.....	.30	25 Tool Tray.....	.55	42 Weight Rod.....	.55
9 Short Yoke.....	.30	26 Rest Standard.....	(Discontinued)	43 Large Bearing Rod.....	.35
10 Long Yoke.....	.60	27 Wood Pitman.....	.25	44 Small Bearing Rod.....	.15
11 Arm.....	2.80	28 Small Pitman Bolt.....	.10	45 Vise Screw.....	1.10
12 Standard.....	4.50	29 Large Pitman Bolt.....	.10	46 Clutch Collar Spring.....	.10
13 Rest Yoke.....	(Discontinued)	30 Dog.....	.15	47 Clutch Lever Handle.....	.20
14 Clutch Lever.....	.75	31 Malleable Thumb Screw.....	.10	48 Pulley Bolt and Handle...	.35
15 Vise Jaw.....	1.60	32 Guide Screw and Nut.....	.20	49 Handwheel Bolt and Handle	.95
16 Rest Base.....	(Discontinued)	33 Gauge Clamp Nut.....	.10		



Parts for Power Hack Saws

No. 91

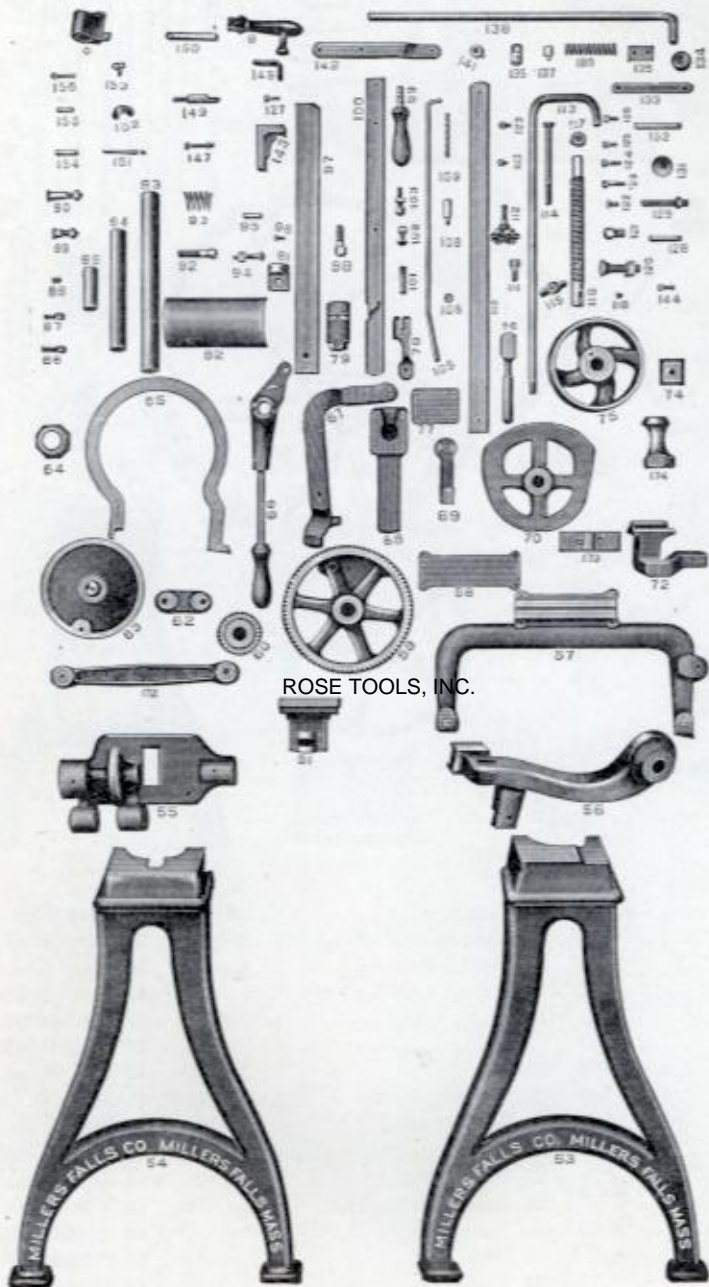



Parts for Power Hack Saws

No. 91

0 Clutch Collar.....	\$ 0.40	111 Weight Bar Screw.....	\$ 0.10
8 Vise Handle.....	.30	112 Weight Screw.....	.10
51 Vise Jaw.....	1.20	113 Gauge Bar.....	.40
53 Front Leg.....	10.20	114 Gauge Bar Clamp Bolt.....	.10
54 Rear Leg.....	10.20	115 Gauge Bar Clamp Bolt Wing Nut.....	.10
55 Head.....	6.70	117 Vise Screw Collar.....	.10
56 Arm.....	3.90	118 Vise Screw Collar Screw.....	.10
57 Frame.....	3.40	120 Vise Nut Clamp Bolt.....	.10
58 Frame Cover.....	.40	121 Vise Jaw Screw.....	.15
59 Large Gear.....	3.60	122 Knockoff Screw.....	.10
60 Small Gear.....	1.35	123 Knockoff Strap Screw.....	.10
62 Link.....	.35	124 Knockoff Lever and Link Screw.....	.10
63 Face Plate.....	1.20	125 Knockoff Center Lever Screw.....	.10
64 Adjusting Screw Check Nut.....	.35	126 Knockoff and Link Screw.....	.10
65 Gear Guard.....	1.25	127 Lifter Box Cover Screw.....	.10
66 Clutch Lever.....	1.10	128 Lifter Box Raising Pin.....	.10
67 Lifter Lever.....	1.25	129 Lifter Box Adjusting Screw.....	.10
68 Lifter Box.....	1.20	131 Lifter Box Disc.....	.10
69 Lifter Cam.....	.20	132 Lifter Box and Lever Pin.....	.15
70 Cam.....	1.40	133 Connecting Strap.....	.15
72 Knockoff Lifter.....	.60	134 Lifter Lever Roll.....	.10
74 Gauge Top.....	.10	135 Elevator Catch Plate.....	.10
75 Pulley.....	2.20	137 Lifter Lever Spring Stud.....	.10
76 Gauge Lifter Handle.....	.20	138 Measuring Lifter Rod.....	.30
77 Lifter Cover.....	.20	139 Measuring Lifter Rod Head.....	.30
78 Clutch Lever Link.....	.25	141 Measuring Lifter Rod Collar.....	.15
79 Adjusting Screw.....	1.05	142 Center Lever.....	.15
81 Elevator Stop.....	.15	143 Measuring Lifter Rod Bearing Casting.....	.30
82 Weight.....	2.00	144 Measuring Lifter Rod Bearing Screw.....	.10
83 Drive Arbor.....	.50	ROSE TOOLS, INC. Measuring Lifter Rod Bearing Rest.....	.10
84 Gear Arbor.....	.50	147 Frame Cover Screw.....	.10
85 Face Plate Arbor.....	.20	149 Short Stud.....	.20
86 Gear Screw.....	.10	150 Long Stud.....	.20
87 Cam and Clutch Collar Screw.....	.10	151 Stud Pin.....	.10
88 Small Gear Screw.....	.10	152 Stud Wing Nut.....	.15
89 Gear Link Screw.....	.10	153 Stud Thumb Screw.....	.10
90 Face Plate Link Screw.....	.15	154 Head Dowel Pin.....	.10
92 Head Lock Screw.....	.15	155 Weight Bar Pin.....	.10
93 Collar Spring.....	.10	156 Cotter Pin.....	.10
94 Pitman Screw.....	.10	160 Lifter Box Disc Screw.....	.10
95 Pulley Pin.....	.10	170 Bed.....	12.40
96 Catch Plate and Gear Guard Screw.....	.10	171 Vise.....	3.85
97 Guide Bar.....	1.60	172 Pitman.....	.60
98 Guide Bar Screw.....	.10	173 Knockoff.....	.10
99 Guide Bar Handle.....	.25	174 Gauge Clamp.....	.40
100 Elevator Bar.....	.75	175 Vise Clamp Bolt.....	.10
101 Elevator Bar Screw.....	.10	176 Vise Swivel Bolt.....	.10
102 Elevator Bar Stop Bolt.....	.10	177 Gauge Bar Clamp Bolt.....	.10
103 Elevator Bar Adjusting Screw.....	.10	178 Vise Screw.....	.65
105 Elevator Bar Trip Rod.....	.10	179 Leg Clamp Bolt.....	.10
106 Elevator Bar Trip Rod Nut.....	.10	180 Lifter Lever Spring.....	.10
108 Elevator Bar Trip Rod Stud.....	.10	181 Stop Dowel Pin.....	.10
109 Elevator Bar Trip Rod Spring.....	.10	182 Vise Jaw Screw.....	.15
110 Weight Bar.....	.60	183 Clutch Washer.....	.15



INDEX

	PAGE		PAGE
Angular Bitstock.....	20	Breast Drill Parts.....	184
Assembling Tool.....	164	Butcher Saw Blades.....	122
Auger Bits (See Bits)		Butcher Saw Frames.....	122
Auger Bit Sets.....	26, 27	Car Bits.....	29, 30
Auger Handles.....	40, 41	Carving Tool Sets.....	172, 173
Augers, Boring Machine.....	35	Center Punches.....	150
Auger, Hollow.....	20	Chain Drills.....	78, 79
Augers, Machine.....	36	Chart, Hack Saw.....	109
Augers, Rafting.....	35	Chucks.....	100-104
Augers, Ring.....	33-35	Chuck Breast Drill.....	67
Augers, Ship.....	31, 32	Chucks, Lathe.....	104
Auto Jack.....	158	Chucks and Drills for Spiral Screw Driver.....	89
Automatic Drills.....	81-86	Circular Glass Cutter.....	133
Automatic Drill Points.....	86	Coping Saw Blades.....	125
Band Saws, Metal.....	113	Coping Saw Frames.....	124, 125
Bearing Scraper.....	160	Corner Brace.....	17
Bench Drills.....	69-76	D Handle for Breast Drills.....	67
Bench Drill Parts.....	180, 181	Drill Brace.....	18
Bench Drill Vises.....	77	Drills:	
Bench Hook.....	142	Automatic.....	81-86
Bits, Auger:		Bench.....	69-76
Electricians' Special.....	24	Breast.....	58-68
Ship.....	28	Chain.....	78, 79
Single Lip.....	24	Hand.....	47-57
Solid Center.....	25	Ratchet.....	80
Sets of.....	26, 27	Drill Parts, Hand and Breast.....	184
Bits, Car.....	29, 30	Drill Points, Automatic.....	86
Bit Braces.....	6-19	Drill Points, Hand.....	57
Bit Extensions.....	33	Drill Points for Spiral Screw Drivers.....	89
Bit Gauges.....	37	Drill Points, Twist.....	57
Bits, Screw Driver.....	93	Drive Punches.....	152, 153
Bitstock, Angular.....	20	Extensions, Bit.....	38, 39
Blades:		File Handle.....	80
Butcher Saw.....	122	Frames:	
Coping Saw.....	125	Butcher Saw.....	122
Fret Saw.....	128	Coping Saw.....	124, 125
Hack Saw.....	106-112	Fret Saw.....	126
Turning Saw.....	123	Hack Saw.....	115-121
Bobs, Plumb.....	142	Jeweler Saw.....	129
Borers, Sill.....	42, 43	Kitchen Saw.....	123
Boring Machine Augers.....	35	Piercing Saw.....	128
Boring Machine (Carpenters').....	45	Turning Saw.....	123
Boring Machine (Electricians').....	44	Fret Saw Blades.....	128
Boring Machine Parts.....	182, 183	Fret Saw Frames.....	126
Boxes, Mitre.....	135-139	Fret Saw Machines.....	127
Braces:		Fret Saw Machine Parts.....	185
Corner.....	17	Fret Saw Sets.....	126
Drill.....	18	Gauges, Bit.....	37
Plain or Sleeve.....	14-16	Gauge Glass Cutter.....	133
Ratchet.....	6-13	Gauge, Jointer.....	141
Whimble.....	19		
Brace Parts.....	178, 179		
Breast Drills.....	58-68		



INDEX (Continued)

	PAGE		PAGE
Glass Cutters.....	131-133	Polishing Heads.....	168-171
Glass Cutter, Circular.....	133	Power Hack Saws.....	174, 175
Glass Cutter, Gauge.....	133	Power Hack Saw Parts.....	191, 192
Grinders, Valve.....	160, 161	Prick Punches.....	151
Grinding Heads.....	168-171	Punches:	
Hack Saw Blades.....	106-112	Assembling.....	164
Hack Saw Chart.....	109	Center.....	150
Hack Saw Frames.....	115-121	Drive.....	152, 153
Hack Saw Machines.....	174, 175	Prick.....	151
Hack Saw Machine Parts.....	191, 192	Sets of.....	154-156
Hand Drills.....	47-57	Rafting Augers.....	35
Hand Drill Parts.....	184	Ratchet Drills.....	80
Hand Drill Points.....	57	Ratchet Screw Drivers.....	90-92
Handles, Auger.....	40, 41	Ratchet Screw Driver Display.....	94
Handle, File.....	80	Rim Wrenches.....	164
Hand Vises.....	144-146	Ring Augers.....	33-35
Heads, Polishing and Grinding.....	168-171	Saw Blades (See Blades):	
Hollow Auger.....	20	Saw Frames (See Frames):	
Hook, Bench.....	142	Saws, Band.....	113
Iron Levels.....	141	Screw Drivers:	
Jack, Auto.....	158	Plain.....	93, 94
Jack Parts—Auto and Truck.....	190	Ratchet.....	90-92
Jack Screws.....	166	Spiral Ratchet.....	87, 88
Jacks, Truck.....	159	Screw Driver Bits.....	93
Jeweler Saw Frames.....	129	Screw Driver Display.....	94
Jointer Gauge.....	141	Screws, Jack.....	166
Joist Tools.....	42, 43	Scroll Saws.....	127
Kitchen Saw Frame.....	142	Ship Augers.....	31, 32
Lathe.....	176	Ship Auger Car Bits.....	30
Lathe Chucks.....	104	SNC Boring.....	42, 43
Lathe Parts.....	185	Socket Wrench Set, Radio.....	91
Levels, Iron.....	141	Soldering Sets.....	165
Machine Bits.....	36	Spiral Ratchet Screw Drivers.....	87, 88
Machines:		Spoke Shaves.....	143
Boring.....	44, 45	Spoke Trimmers.....	146
Fret Saw.....	127	Tap Wrenches.....	162, 163
Hack Saw.....	174, 175	Tool Holders.....	96-98
Mitre Boxes.....	135-139	Truck Jacks.....	159
Mitre Box Parts.....	186-189	Turning Saw Blades.....	123
Mitre Planer.....	140	Turning Saw Frames.....	123
Nail Sets.....	148, 149	Twist Drill Points.....	57
Piercing Saws.....	128	Valve Grinders.....	160, 161
Planer, Mitre.....	140	Vises:	
Plumb Bobs.....	142	Bench Drill.....	77
Points, Automatic Drill.....	86	Hand.....	144-146
Point, Hand Drill.....	57	Whimble Brace.....	19
		Wrenches, Rim.....	164
		Wrench Set, Radio Socket.....	91
		Wrenches, Tap.....	162, 163

ROSE TOOLS, INC.



INDEX

	PAGE		PAGE
Angular Bitstock	20	Breast Drill Parts	184
Assembling Tool	164	Butcher Saw Blades	122
Auger Bits (See Bits)		Butcher Saw Frames	122
Auger Bit Sets	26, 27	Car Bits	29, 30
Auger Handles	40, 41	Carving Tool Sets	172, 173
Augers, Boring Machine	35	Center Punches	150
Auger, Hollow	20	Chain Drills	78, 79
Augers, Machine	36	Chart, Hack Saw	109
Augers, Rafting	35	Chucks	100-104
Augers, Ring	33-35	Chuck Breast Drill	67
Augers, Ship	31, 32	Chucks, Lathe	104
Auto Jack	158	Chucks and Drills for Spiral Screw Driver	89
Automatic Drills	81-86	Circular Glass Cutter	133
Automatic Drill Points	86	Coping Saw Blades	125
Band Saws, Metal	113	Coping Saw Frames	124, 125
Bearing Scraper	160	Corner Brace	17
Bench Drills	69-76	D Handle for Breast Drills	67
Bench Drill Parts	180, 181	Drill Brace	18
Bench Drill Vises	77	Drills:	
Bench Hook	142	Automatic	81-86
Bits, Auger:		Bench	69-76
Electricians' Special	24	Breast	58-68
Ship	28	Chain	78, 79
Single Lip	24	Hand	47-57
Solid Center	25	Ratchet	80
Sets of	26, 27	Drill Parts, Hand and Breast	184
Bits, Car	29, 30	Drill Points, Automatic	86
Bit Braces	6-19	Drill Points, Hand	57
Bit Extensions	38	Drill Points for Spiral Screw Drivers	89
Bit Gauges	37	Drill Points, Twist	57
Bits, Screw Driver	93	Drive Punches	152, 153
Bitstock, Angular	20	Extensions, Bit	38, 39
Blades:		File Handle	80
Butcher Saw	122	Frames:	
Coping Saw	125	Butcher Saw	122
Fret Saw	128	Coping Saw	124, 125
Hack Saw	106-112	Fret Saw	126
Turning Saw	123	Hack Saw	115-121
Bobs, Plumb	142	Jeweler Saw	129
Borers, Sill	42, 43	Kitchen Saw	123
Boring Machine Augers	35	Piercing Saw	128
Boring Machine (Carpenters')	45	Turning Saw	123
Boring Machine (Electricians')	44	Fret Saw Blades	128
Boring Machine Parts	182, 183	Fret Saw Frames	126
Boxes, Mitre	135-139	Fret Saw Machines	127
Braces:		Fret Saw Machine Parts	185
Corner	17	Fret Saw Sets	126
Drill	18	Gauges, Bit	37
Plain or Sleeve	14-16	Gauge Glass Cutter	133
Ratchet	6-13	Gauge, Jointer	141
Whimble	19		
Brace Parts	178, 179		
Breast Drills	58-68		

INDEX (Continued)

	PAGE		PAGE
Glass Cutters.....	131-133	Polishing Heads.....	168-171
Glass Cutter, Circular.....	133	Power Hack Saws.....	174, 175
Glass Cutter, Gauge.....	133	Power Hack Saw Parts.....	191, 192
Grinders, Valve.....	160, 161	Prick Punches.....	151
Grinding Heads.....	168-171	Punches:	
Hack Saw Blades.....	106-112	Assembling.....	164
Hack Saw Chart.....	109	Center.....	150
Hack Saw Frames.....	115-121	Drive.....	152, 153
Hack Saw Machines.....	174, 175	Prick.....	151
Hack Saw Machine Parts.....	191, 192	Sets of.....	154-156
Hand Drills.....	47-57	Rafting Augers.....	35
Hand Drill Parts.....	184	Ratchet Drills.....	80
Hand Drill Points.....	57	Ratchet Screw Drivers.....	90-92
Handles, Auger.....	40, 41	Ratchet Screw Driver Display.....	94
Handle, File.....	80	Rim Wrenches.....	164
Hand Vises.....	144-146	Ring Augers.....	33-35
Heads, Polishing and Grinding.....	168-171	Saw Blades (See Blades):	
Hollow Auger.....	20	Saw Frames (See Frames):	
Hook, Bench.....	142	Saws, Band.....	113
Iron Levels.....	141	Screw Drivers:	
Jack, Auto.....	158	Plain.....	93, 94
Jack Parts—Auto and Truck.....	190	Ratchet.....	90-92
Jack Screws.....	166	Spiral Ratchet.....	87, 88
Jacks, Truck.....	159	Screw Driver Bits.....	93
Jeweler Saw Frames.....	129	Screw Driver Display.....	94
Jointer Gauge.....	141	Screws, Jack.....	166
Joist Tools.....	42, 43	Scroll Saws.....	127
Kitchen Saw Frame.....	141	Ship Augers.....	31, 32
Lathe.....	176	Ship Auger Car Bits.....	30
Lathe Chucks.....	104	Socket Wrench Set, Radio.....	91
Lathe Parts.....	185	Soldering Sets.....	165
Levels, Iron.....	141	Spiral Ratchet Screw Drivers.....	87, 88
Machine Bits.....	36	Spoke Shaves.....	143
Machines:		Spoke Trimmers.....	146
Boring.....	44, 45	Tap Wrenches.....	162, 163
Fret Saw.....	127	Tool Holders.....	96-98
Hack Saw.....	174, 175	Truck Jacks.....	159
Mitre Boxes.....	135-139	Turning Saw Blades.....	123
Mitre Box Parts.....	186-189	Turning Saw Frames.....	123
Mitre Planer.....	140	Twist Drill Points.....	57
Nail Sets.....	148, 149	Valve Grinders.....	160, 161
Piercing Saws.....	128	Vises:	
Planer, Mitre.....	140	Bench Drill.....	77
Plumb Bobs.....	142	Hand.....	144-146
Points, Automatic Drill.....	86	Whimble Brace.....	19
Point, Hand Drill.....	57	Wrenches, Rim.....	164
		Wrench Set, Radio Socket.....	91
		Wrenches, Tap.....	162, 163

ROSE TOOLS, INC.



INDEX

	PAGE		PAGE
Angular Bitstock	20	Breast Drill Parts	184
Assembling Tool	164	Butcher Saw Blades	122
Auger Bits (See Bits)		Butcher Saw Frames	122
Auger Bit Sets	26, 27	Car Bits	29, 30
Auger Handles	40, 41	Carving Tool Sets	172, 173
Augers, Boring Machine	35	Center Punches	150
Auger, Hollow	20	Chain Drills	78, 79
Augers, Machine	36	Chart, Hack Saw	109
Augers, Rafting	35	Chucks	100-104
Augers, Ring	33-35	Chuck Breast Drill	67
Augers, Ship	31, 32	Chucks, Lathe	104
Auto Jack	158	Chucks and Drills for Spiral Screw Driver	89
Automatic Drills	81-86	Circular Glass Cutter	133
Automatic Drill Points	86	Coping Saw Blades	125
Band Saws, Metal	113	Coping Saw Frames	124, 125
Bearing Scraper	160	Corner Brace	17
Bench Drills	69-76	D Handle for Breast Drills	67
Bench Drill Parts	180, 181	Drill Brace	18
Bench Drill Vises	77	Drills:	
Bench Hook	142	Automatic	81-86
Bits, Auger:		Bench	69-76
Electricians' Special	24	Breast	58-68
Ship	28	Chain	78, 79
Single Lip	24	Hand	47-57
Solid Center	25	Ratchet	80
Sets of	26, 27	Drill Parts, Hand and Breast	184
Bits, Car	29, 30	Drill Points, Automatic	86
Bit Braces	6-19	Drill Points, Hand	57
Bit Extensions	38	Drill Points for Spiral Screw Drivers	89
Bit Gauges	37	Drill Points, Twist	57
Bits, Screw Driver	93	Drive Punches	152, 153
Bitstock, Angular	20	Extensions, Bit	38, 39
Blades:		File Handle	80
Butcher Saw	122	Frames:	
Coping Saw	125	Butcher Saw	122
Fret Saw	128	Coping Saw	124, 125
Hack Saw	106-112	Fret Saw	126
Turning Saw	123	Hack Saw	115-121
Bobs, Plumb	142	Jeweler Saw	129
Borers, Sill	42, 43	Kitchen Saw	123
Boring Machine Augers	35	Piercing Saw	128
Boring Machine (Carpenters')	45	Turning Saw	123
Boring Machine (Electricians')	44	Fret Saw Blades	128
Boring Machine Parts	182, 183	Fret Saw Frames	126
Boxes, Mitre	135-139	Fret Saw Machines	127
Braces:		Fret Saw Machine Parts	185
Corner	17	Fret Saw Sets	126
Drill	18	Gauges, Bit	37
Plain or Sleeve	14-16	Gauge Glass Cutter	133
Ratchet	6-13	Gauge, Jointer	141
Whimble	19		
Brace Parts	178, 179		
Breast Drills	58-68		



INDEX (Continued)

	PAGE		PAGE
Glass Cutters.....	131-133	Polishing Heads.....	168-171
Glass Cutter, Circular.....	133	Power Hack Saws.....	174, 175
Glass Cutter, Gauge.....	133	Power Hack Saw Parts.....	191, 192
Grinders, Valve.....	160, 161	Prick Punches.....	151
Grinding Heads.....	168-171	Punches:	
Hack Saw Blades.....	106-112	Assembling.....	164
Hack Saw Chart.....	109	Center.....	150
Hack Saw Frames.....	115-121	Drive.....	152, 153
Hack Saw Machines.....	174, 175	Prick.....	151
Hack Saw Machine Parts.....	191, 192	Sets of.....	154-156
Hand Drills.....	47-57	Rafting Augers.....	35
Hand Drill Parts.....	184	Ratchet Drills.....	80
Hand Drill Points.....	57	Ratchet Screw Drivers.....	90-92
Handles, Auger.....	40, 41	Ratchet Screw Driver Display.....	94
Handle, File.....	80	Rim Wrenches.....	164
Hand Vises.....	144-146	Ring Augers.....	33-35
Heads, Polishing and Grinding.....	168-171	Saw Blades (See Blades):	
Hollow Auger.....	20	Saw Frames (See Frames):	
Hook, Bench.....	142	Saws, Band.....	113
Iron Levels.....	141	Screw Drivers:	
Jack, Auto.....	158	Plain.....	93, 94
Jack Parts—Auto and Truck.....	190	Ratchet.....	90-92
Jack Screws.....	166	Spiral Ratchet.....	87, 88
Jacks, Truck.....	159	Screw Driver Bits.....	93
Jeweler Saw Frames.....	129	Screw Driver Display.....	94
Jointer Gauge.....	141	Screws, Jack.....	166
Joist Tools.....	42, 43	Scroll Saws.....	127
Kitchen Saw Frame.....	141	Ship Augers.....	31, 32
Lathe.....	176	Ship Auger Car Bits.....	30
Lathe Chucks.....	104	SN Borers.....	42, 43
Lathe Parts.....	185	Socket Wrench Set, Radio.....	91
Levels, Iron.....	141	Soldering Sets.....	165
Machine Bits.....	36	Spiral Ratchet Screw Drivers.....	87, 88
Machines:		Spoke Shaves.....	143
Boring.....	44, 45	Spoke Trimmers.....	146
Fret Saw.....	127	Tap Wrenches.....	162, 163
Hack Saw.....	174, 175	Tool Holders.....	96-98
Mitre Boxes.....	135-139	Truck Jacks.....	159
Mitre Box Parts.....	186-189	Turning Saw Blades.....	123
Mitre Planer.....	140	Turning Saw Frames.....	123
Nail Sets.....	148, 149	Twist Drill Points.....	57
Piercing Saws.....	128	Valve Grinders.....	160, 161
Planer, Mitre.....	140	Vises:	
Plumb Bobs.....	142	Bench Drill.....	77
Points, Automatic Drill.....	86	Hand.....	144-146
Point, Hand Drill.....	57	Whimble Brace.....	19
		Wrenches, Rim.....	164
		Wrench Set, Radio Socket.....	91
		Wrenches, Tap.....	162, 163