

SC
3585
A

MAY, 1950
LATHE BULLETIN 6L-1A
Replaces Bulletin 6L-1

Atlas

REPAIR PARTS LIST FOR ATLAS 6" METAL LATHE

CATALOG No. 618

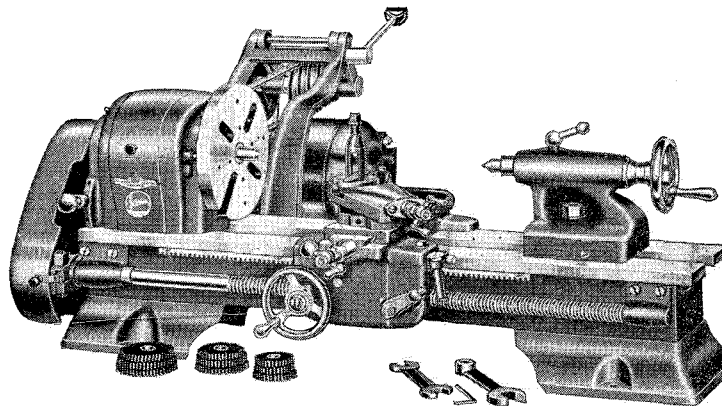

ATLAS PRESS COMPANY - KALAMAZOO 13D - MICHIGAN - U.S.A.

REV 1 2013/06/24

ORDERING INFORMATION

IMPORTANT: The following information must be furnished on all repair part orders.

1. Quantity Required
2. PART NUMBER and Name of Part
3. Model and Serial Number of Lathe

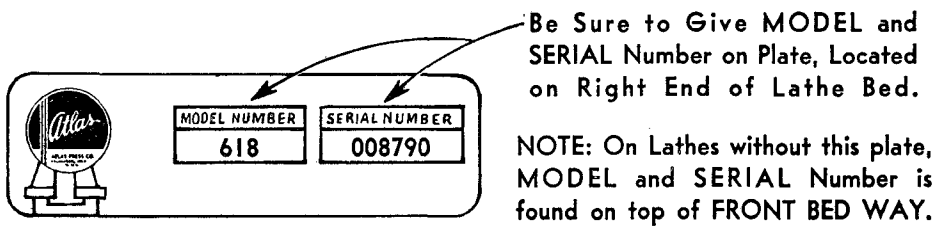
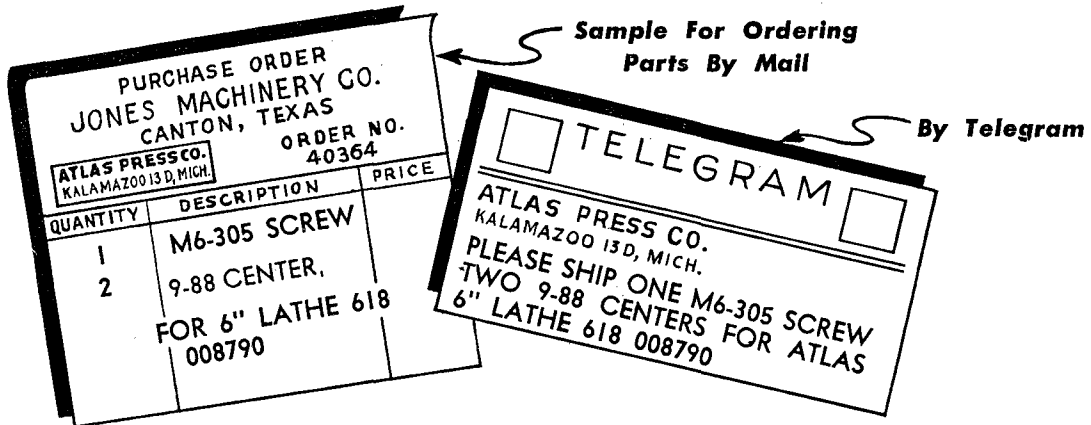

Parts shown without part numbers are standard parts and should be purchased locally. We reserve the right to make changes in design and specifications without notice.

INDEX

FOR LATHE PARTS AND PRICES

	Page
Unit Assemblies	3
Carriage and Compound	4-5
Headstock	6
Lead Screw, Change Gears, Gear Guard and Lathe Bed	7
Countershaft and Tailstock	8

Atlas 6" LATHE UNIT ASSEMBLIES

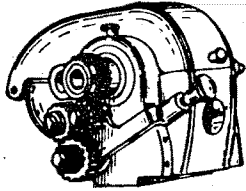

M6-2X HEADSTOCK
ASSEMBLY
SEE PAGE 6

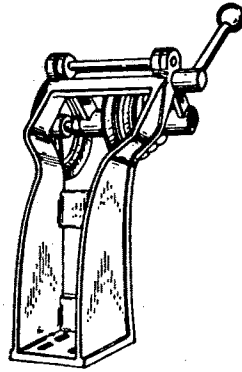

M6-20BX COUNTERSHAFT
ASSEMBLY
SEE PAGE 8

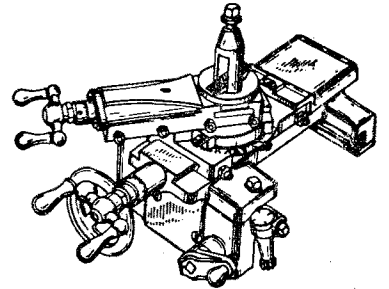

M6-9XY CARRIAGE ASSEMBLY
SEE PAGE 4 and 5

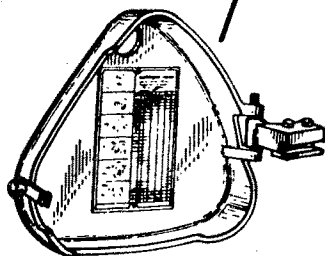
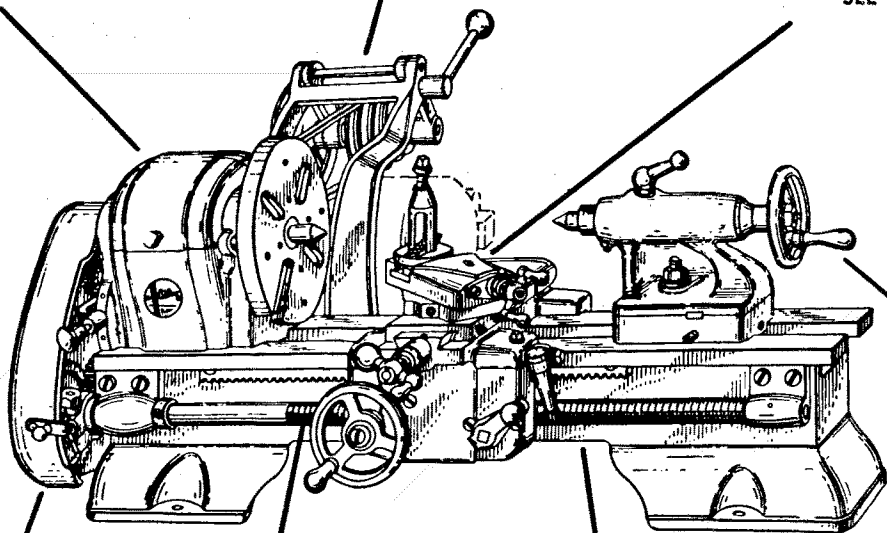

M6-28X GEAR GUARD
ASSEMBLY
SEE PAGE 7

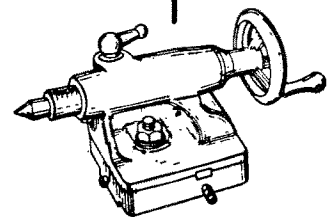

M6-5X TAILSTOCK ASSEMBLY
SEE PAGE 8

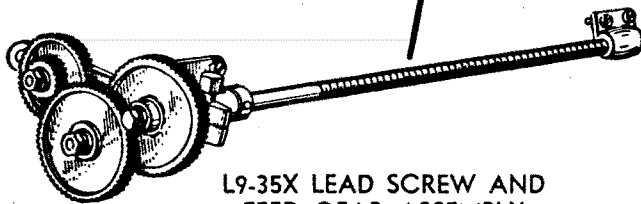

L9-35X LEAD SCREW AND
FEED GEAR ASSEMBLY
SEE PAGE 7

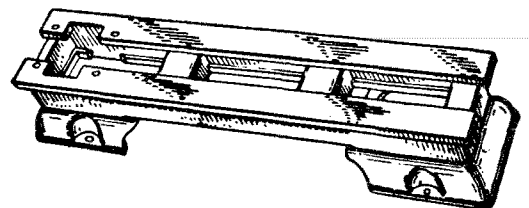

L9-IX BED, LEGS, AND
RACK ASSEMBLY
SEE PAGE 7

CARRIAGE PARTS LIST

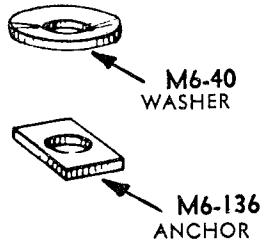
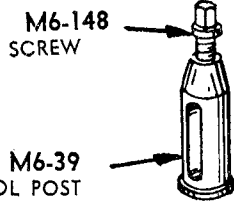
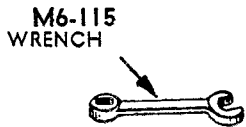

M6-39X TOOL POST ASSEMBLY
LESS WRENCH

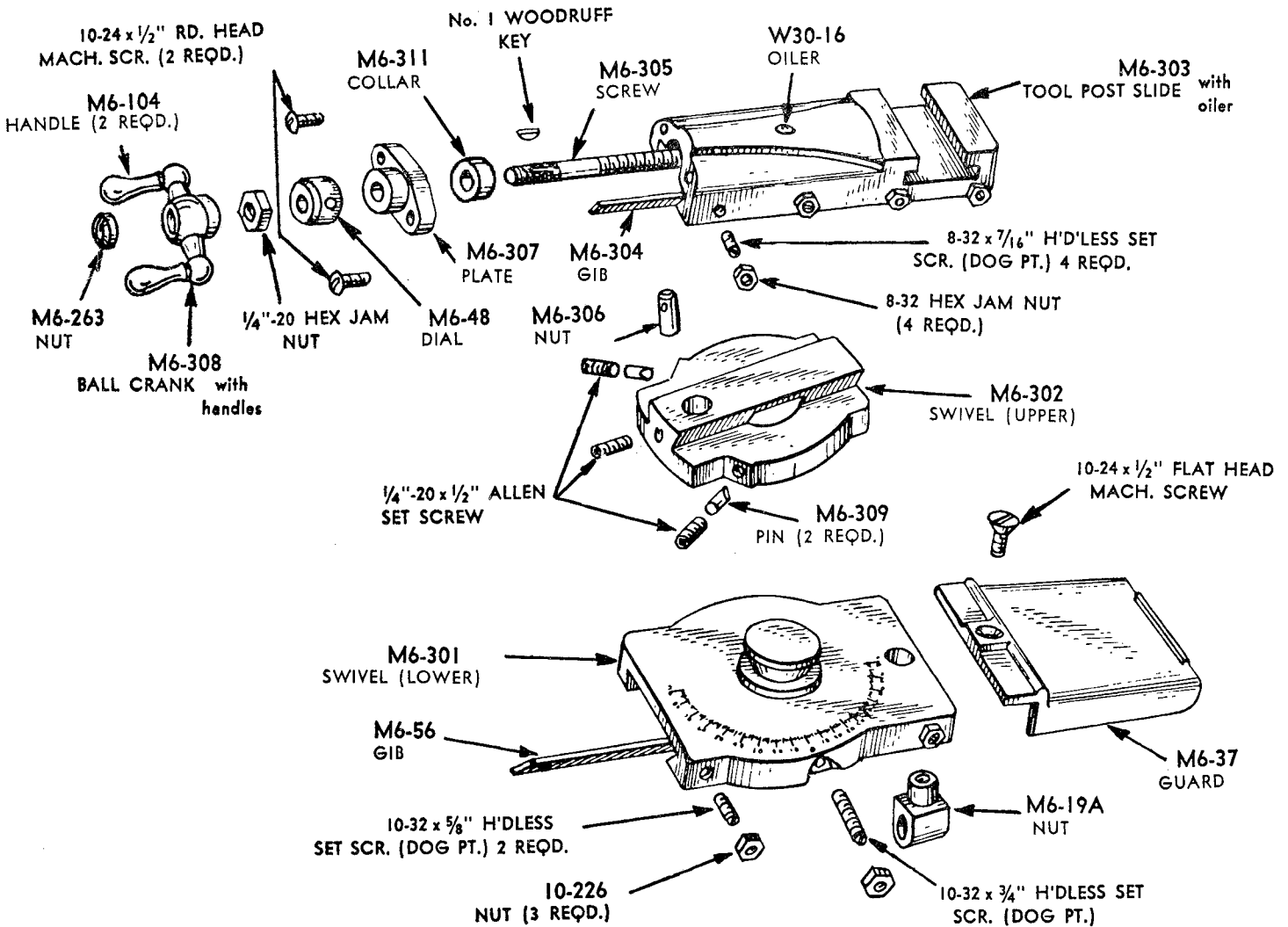
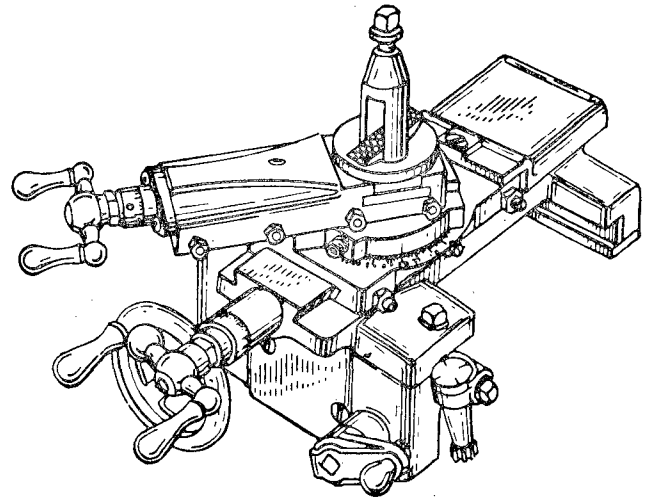

M6-301X COMPOUND REST ASSEMBLY

CARRIAGE PARTS LIST

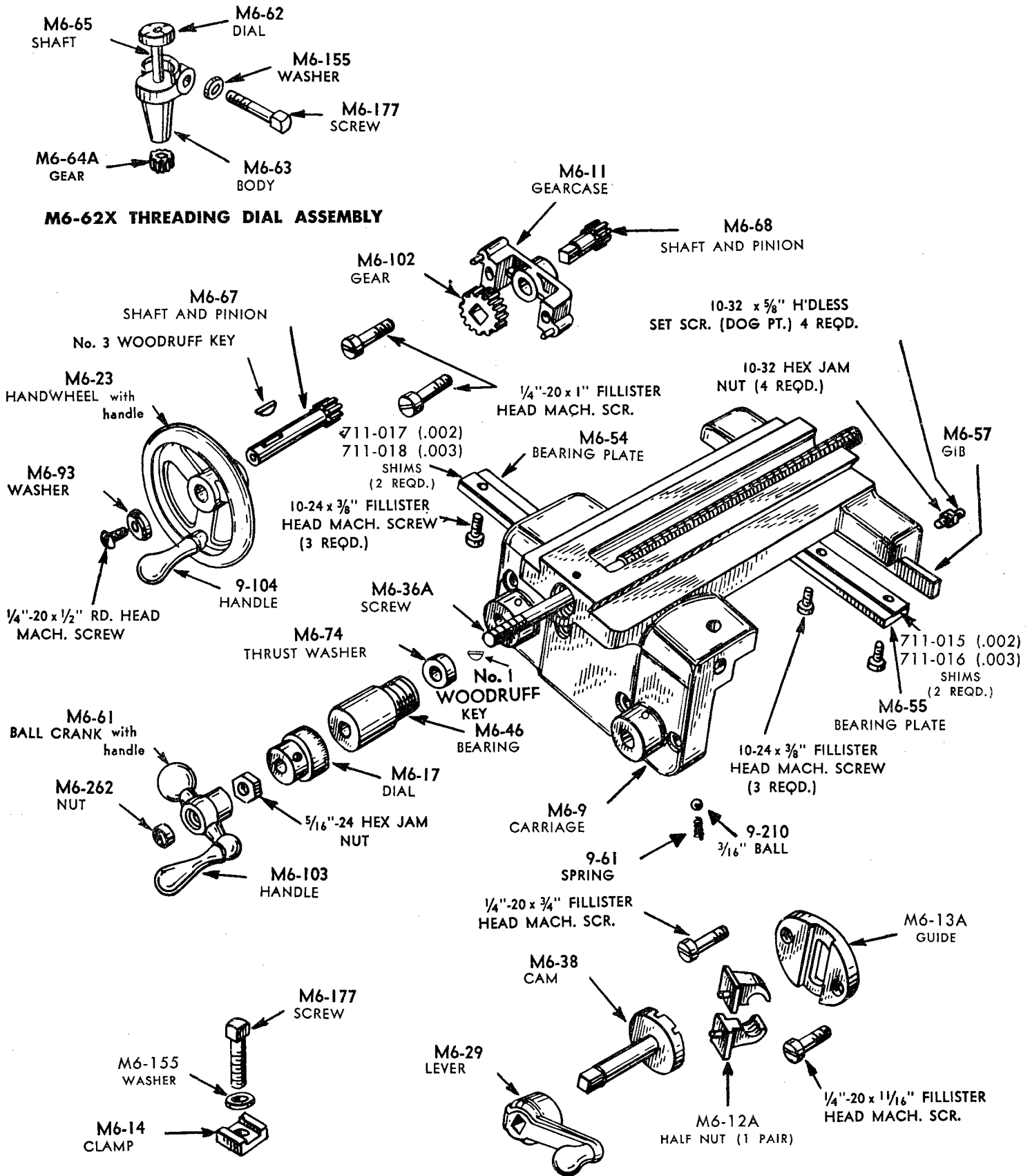

HEADSTOCK PARTS LIST

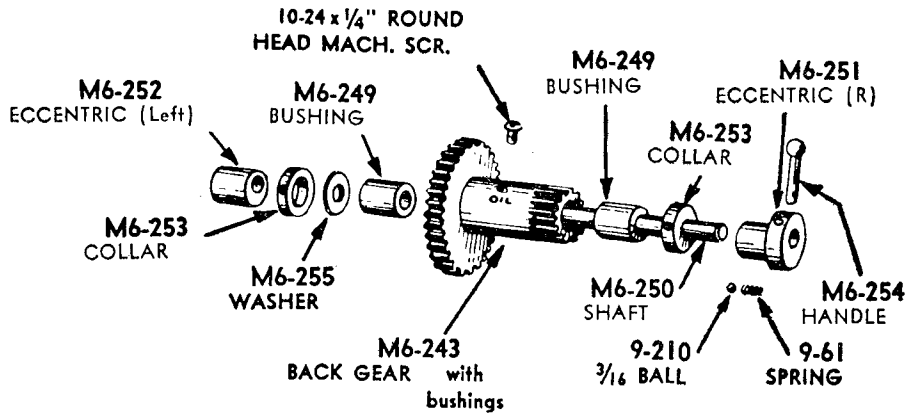
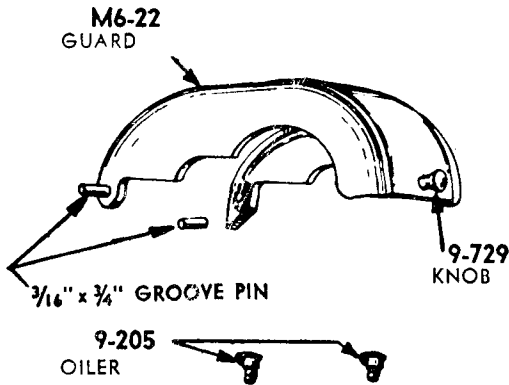

M6-243X BACK GEAR ASSEMBLY
Including Spindle Back Gears

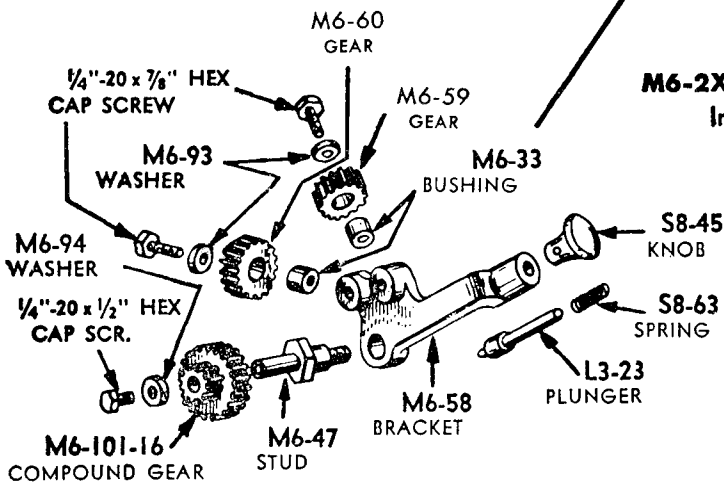
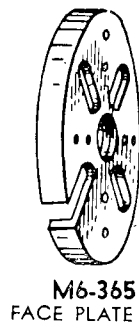
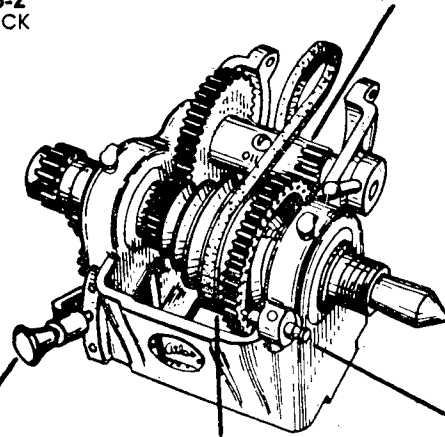
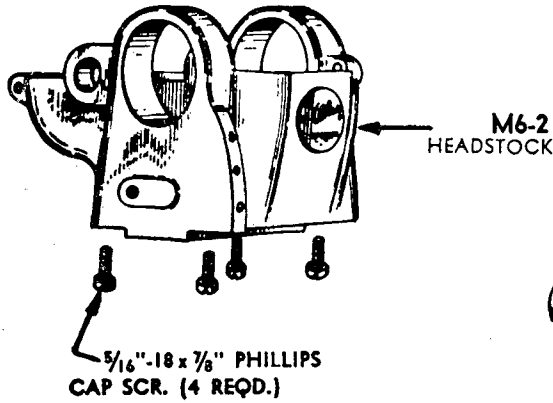

M6-58X TUMBLER ASSEMBLY

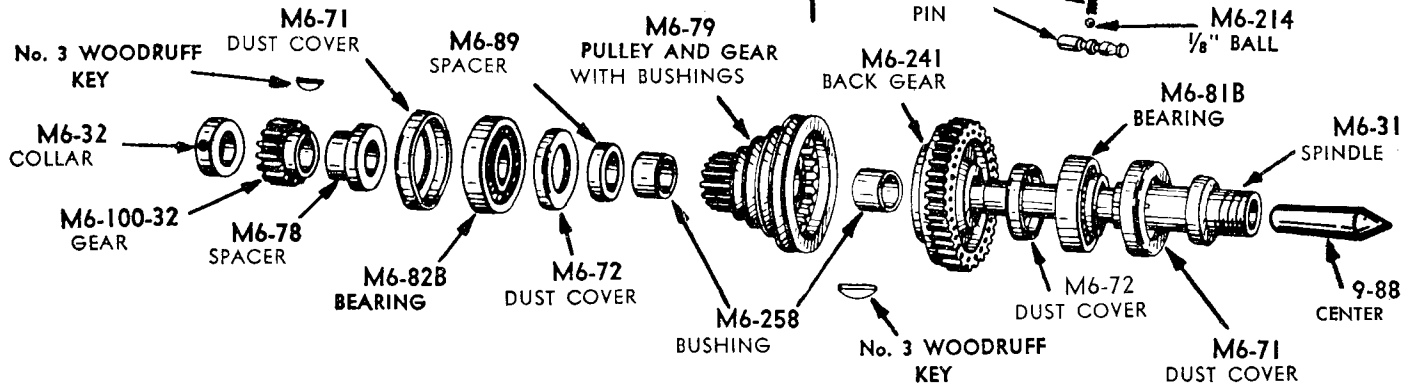
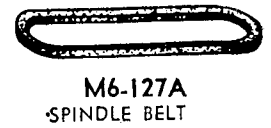
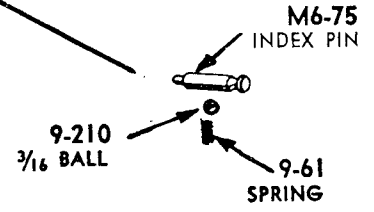

M6-31X SPINDLE ASSEMBLY

LEAD SCREW, CHANGE GEARS, GEAR GUARD, AND LATHE BED PARTS LIST

1/4"-20 x 3/8" FILLISTER HEAD
MACH. SCREW

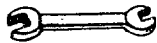
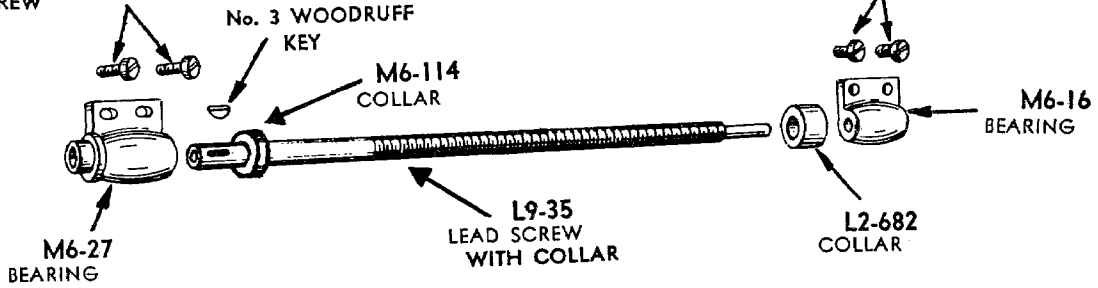

M6-312
WRENCH

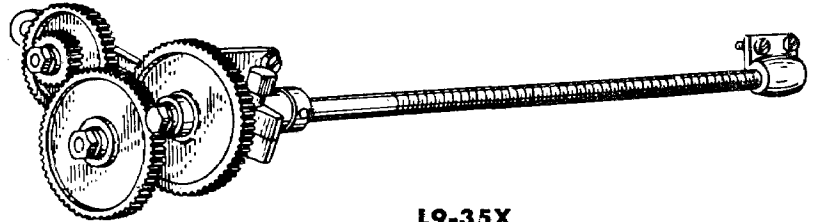

L9-35X
LEAD SCREW AND FEED GEAR ASSEMBLY

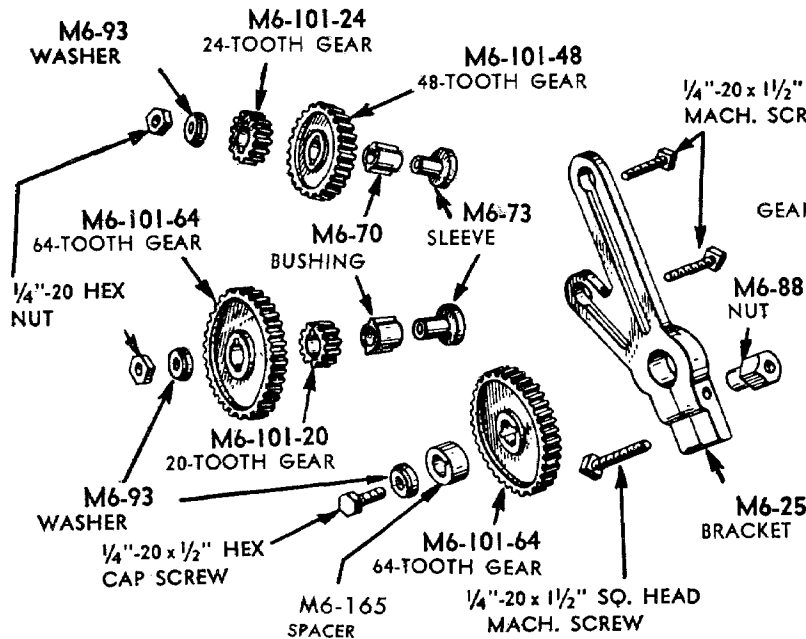

**M6-25X CHANGE GEAR
BRACKET ASSEMBLY**

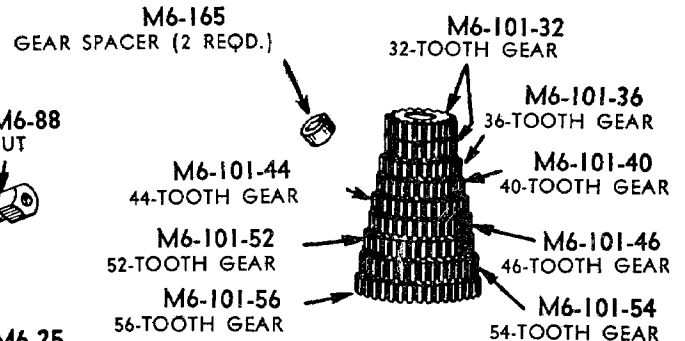

M6-101X CHANGE GEAR ASSEMBLY
LESS SPACER

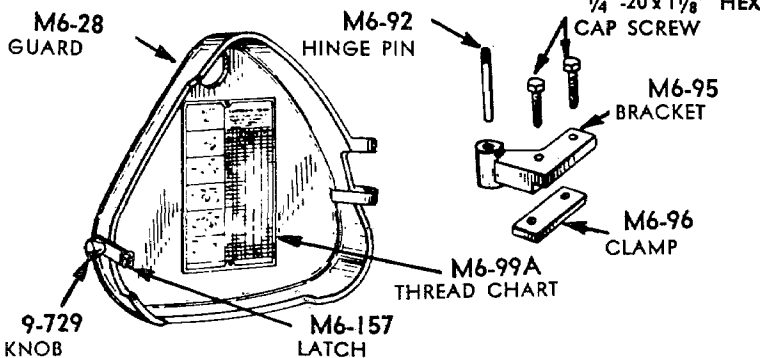

M6-28X GEAR GUARD ASSEMBLY

L9-1
BED—PRICES ON APPLICATION

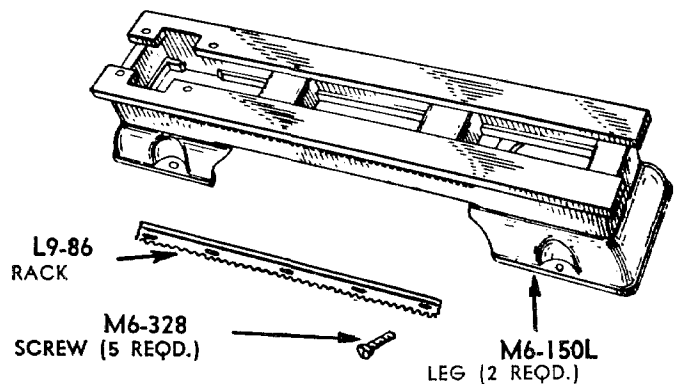

L9-1X BED, LEGS, AND RACK ASSEMBLY

COUNTERSHAFT AND TAILSTOCK PARTS LIST

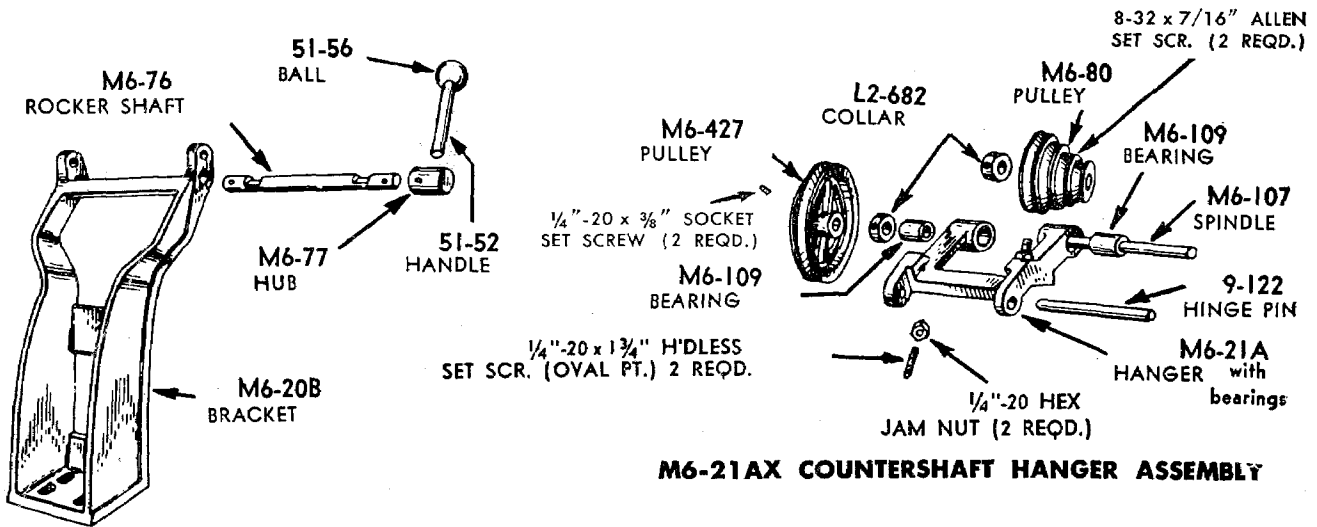

M6-21AX COUNTERSHAFT HANGER ASSEMBLY

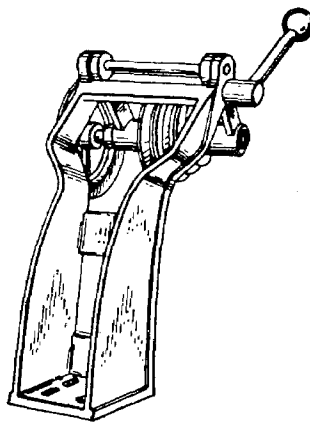
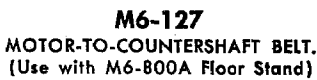
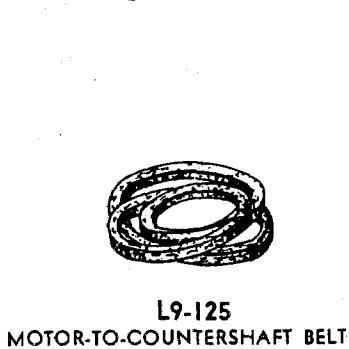

M6-20BX COUNTERSHAFT ASSEMBLY
WITH MOTOR BELT AND PULLEY

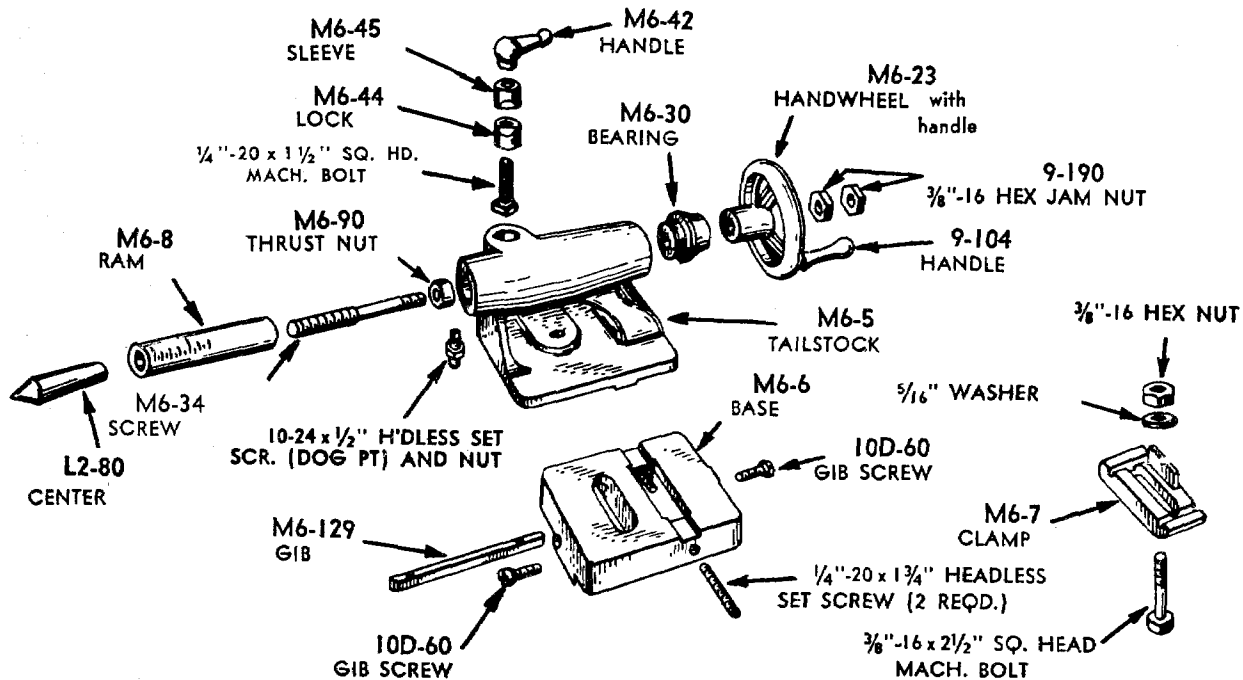
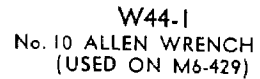
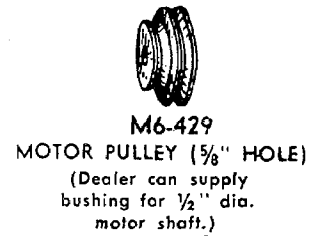

M6-5X TAILSTOCK ASSEMBLY