

MYFORD

3 $\frac{1}{8}$ in. & 3 $\frac{1}{2}$ in.
LATHE S



Instructions

in their
Operation, Adjustment
& the use of Accessories

MYFORD ENGINEERING COMPANY LIMITED
HEKSTON, NOTTINGHAM

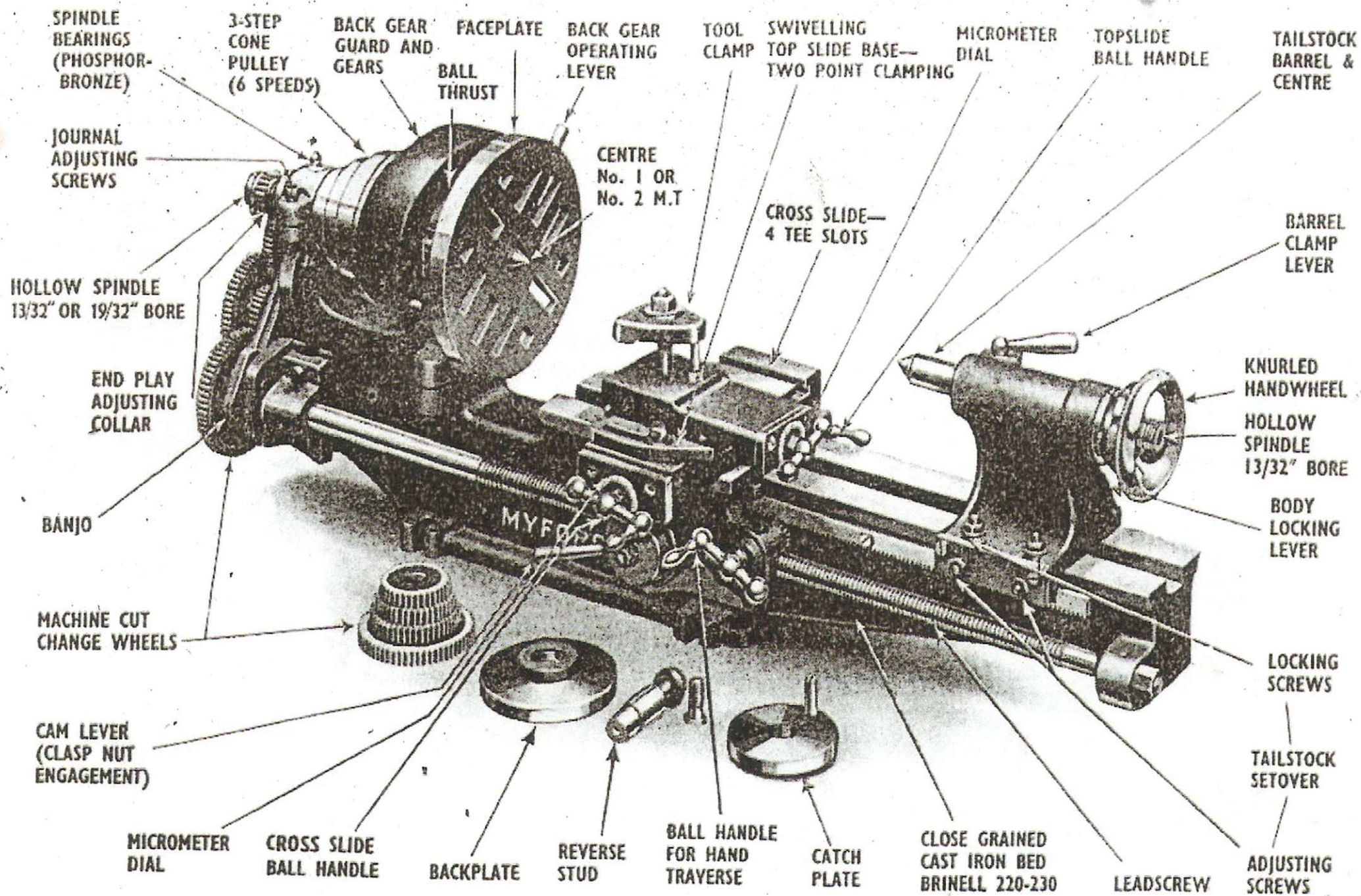



3 1/8. and 3 1/2in. Lathes

The primary object in the design of these Lathes is to provide a simple and moderately priced universal machine tool, equally suited to the requirements of Amateur and Professional users. All essential features of design to promote accuracy, rigidity and handiness of manipulation have been very carefully studied. Evidence of the success of this policy is to be found in the popularity of these Lathes, the sale of which has increased steadily ever since their production, so that they are now shipped in large quantities to all parts of the British Empire and other countries overseas.

INSTALLATION

The ability of any Lathe to produce accurate work depends in no small measure on the care exercised in its installation. It is advisable, when fixing a Lathe to a wooden or metal bench, to ensure that the bolting surface is dead flat and levelled up both ways. Lathes fitted to stands should be carefully packed under the feet to level the bed and remove the least tendency to rocking.

Myford Lathes have the bed designed on the cantilever principle, supported on one base surface under the centre of gravity, and are thus much less liable to distortion than Lathes with widely separated end supports. The underside of the base is machined to further facilitate accurate setting. These advantages should not, however, encourage carelessness in installation. Any inequalities in the bench surface or floor should be corrected by packing of a permanent nature; careful levelling is not only sound practice, but will also be found an advantage when setting up and marking out work from the Lathe bed.

DRIVING POWER

Myford Lathes are equipped for operation either by treadle, lineshaft or individual motor, the alternative forms of equipment for these purposes being as follows:

STAND AND TREADLE (MA51 for 3 1/8 in. Lathe and MA52 for 3 1/2 in. Lathe)

These consist of massive cast iron stands on which the Lathe is supported, incorporating a treadle gear with heavy three-

step flywheel, from which the Lathe headstock is driven by flat belting. The steps of the flywheel are designed to provide the widest possible selection of mandrel speeds, to deal with every range of work from the heaviest castings to light bar-work.

FOOT MOTOR (MA 58 light type and MA 58A heavier type)
These are provided for use with bench-mounted Lathes and consist of a treadle and flywheel similar to the above, but fitted to a small unit stand which may be bolted to the foot of the bench or the floor.

POWER COUNTERSHAFTS (MA59 and MA59A heavier type)
Two types of countershafts, both applicable to driving from an existing lineshaft and in the case of MA59A also from an electric motor, are available. These incorporate hangers with swivelling bearings, cone pulley, and fast and loose pulleys with striking fork control rod. The hangers are adaptable either to overhead or wall fitting and the control gear is adjustable to suit position.

MOTOR COUNTERSHAFT (MA60)

This is intended for use with an individual electric motor, controlled directly by switch, and is therefore not equipped with belt control gear, the driving pulley being single and secured to the shaft. The hangers have swivelling bearings and are primarily intended for overhead mounting.

UNIT COUNTERSHAFT (MA61)

The bearings in this case are incorporated in a cast frame to form a single unit which may be bolted down to the bench behind the Lathe. Please specify clearly whether for wall or overhead mounting, so that the oiling arrangements may be modified to suit. This countershaft is also intended for use in connection with individual electric motor having switch control.

BENCH MOTOR UNIT (MA97 for flat belt and MA97A for vee-rope)

The compactness of this arrangement is a great asset in cases where space is limited. Means are provided for adjusting the belt tension, or for completely releasing it when changing from one step of the cone pulley to another. Applicable either to endless flat belts or vee-ropes.

MOTORISED LATHE STAND UNIT (MA80 for 3 1/8 in. Lathe; MA81 and MA103 for 3 1/2 in. Lathe)

The motor in this case is attached to the Lathe stand and drives upwards to a countershaft mounted on a bracket behind the headstock. This arrangement takes up even less room than the bench motor unit and renders the lathe completely portable, without interference with the driving gear. Endless belts are used, and provision for adjustment is incorporated. Where flat belts are used they should be crossed to increase driving torque.

ADJUSTING AND USING THE LATHE

One of the first essentials in obtaining efficient service and long life from a Lathe is to keep all working parts clean and adequately lubricated. Dust and swarf should be kept out of bearings and slides, and a good quality thin lubricating oil used sparingly, but at frequent intervals. A new Lathe should be carefully run in at moderate speed until the mandrel bearings are properly bedded down; neither heavy work nor high speeds should be attempted until running in is completed.

HEADSTOCK

The correct adjustment of the mandrel bearings is a most important factor in producing accurate work. End play can be taken up by adjusting the screwed collar at the rear of the mandrel, and journal slackness by tightening the set screws on the front and rear headstock bearings. In either case no perceptible play should be allowed, but on no account should bearings be tightened to such an extent as to introduce friction. When once properly adjusted, the mandrel bearings will not require further attention for some hundreds of working hours, so long as lubrication is properly attended to. Frequent tinkering with them is neither necessary nor desirable.

BACK GEAR.

This is a simple form of double speed-reducing gear which enables the Lathe to be run at one-sixth the speed of the cone pulley. To engage the back gear, the grub screw in the small step of the mandrel cone pulley is unscrewed until it disengages from the mandrel and allows the pulley to turn freely thereon; the lever on the eccentric bearing on the backshaft is then pulled forward to bring the gears into mesh. It is good practice to take the grub screw completely out of the pulley and insert oil, to ensure thorough lubrication of the spindle.

The back gear can also be used as a means of locking the mandrel in cases where it is necessary to hold it in a stationary position. On no account must the gears brought into mesh whilst the mandrel is running. Adjustment of mesh may be effected by varying the position of the engaging lever, and the gears may be locked in or out of mesh by tightening the screw on the backshaft bearing. To disengage the back gear, put the gears out of mesh and turn the shaft or pulley until the hole for the grub screw lines up with the flat on the mandrel; the screw will then enter a depression in the mandrel and when fully tightened will provide a secure drive. The back gear wheels are protected by a cast iron guard, which not only serves as a complete protection to both operator and mechanism, but also provides a convenient hand rest, the utility of which will be particularly appreciated when the Lathe is driven by foot power.

MANDREL

This is of substantial dimensions, accurately made and ground to close limits, and runs in bearings of ample area. End thrust is taken by a flat track type ball thrust bearing. Two types of Mandrel, both hollow throughout, are available, viz.: $\frac{5}{8}$ in. bore with No. 1 Morse Taper Nose and $19/32$ in. bore with No. 2 Morse Taper Nose; the latter type can only be supplied for Lathes fitted with tumbler reverse.

SCREWCUTTING AND SELF-ACTING TRAVERSE

The standard screwcutting equipment for Myford Lathes comprises a set of ten change wheels with two mounting studs, two driving collars and a distance washer; these accessories enable the change wheels to be set up on the banjo at the outer end of the Lathe mandrel so as to provide a very wide range of gear ratios between the mandrel and the lead screw. After placing the required gear wheel on the end of the mandrel, the driving collar is assembled with its peg engaging in the hole in the gear and its set screw tightened down on to the flat on the mandrel. The gear on the lead screw is secured in like manner, but in this case allowance is made for accommodating two gears, or one gear and a distance washer, to enable compound trains to be set up. Intermediate gears are set up on the two studs, which are adjusted to the required position for meshing up by means of the slotted quadrant, the latter also being radially adjustable about the lead screw centre for the same purpose. When setting up compound trains, the two gears on each stud must be positively coupled together by dowel pins inserted in the holes in the gear wheel faces. These may be made as required from pieces of $3/32$ in. steel wire, cut to a length of $3/8$ in.

To cut right-hand threads or provide automatic traverse from right to left, the lead screw must revolve in the opposite direction to the Lathe mandrel; this is effected by using two intermediate studs. To cut left-hand threads an extra reversing stud must be introduced to reverse the direction of the lead screw; any spare change wheel may be used on this stud, as it simply constitutes an "idler," and does not affect the ratio of the complete gear train.

In the case of Lathes fitted with a tumbler reverse gear to the screwcutting gear, the need for fitting an extra reversing stud is, of course, eliminated.

The adjustment of the gears on the banjo should enable them to mesh positively but not too tightly; a slight amount of backlash should be allowed, to avoid the risk of jamming the gear teeth. Gears should never be engaged whilst the Lathe is running, as the shock may cause breakage of the teeth, and although, in the case of the tumbler reverse gear, steel pinions are used to improve the resistance to impact, discretion in engaging them is still advisable.

As the pitch of the lead screw on Myford Lathes is 8 t.p.i., the gear ratio required for any given thread depends on the ratio of that particular thread to 8. That is to say, that if the thread to be cut is, say, 16 t.p.i., the gears must be arranged so that the mandrel revolves twice to one revolution of the lead screw; thus, for 12 t.p.i., the ratio is $1\frac{1}{2}$ to 1, and so on. The intelligent use of simple arithmetic will therefore enable the user to set up a gear train for any required pitch within the range of the gears provided, but in order to simplify matters and save time, a screwcutting chart, reproduced on a later page, is provided with each lathe, showing the trains of gears required to obtain the usual Whitworth and Metric pitches.

Self-acting traverse is obtained simply by setting up a train of gears to produce a high ratio of reduction, or, in other words, to cut a very fine thread. The arrangement of gears for self-acting feeds is also specified in the chart.

The ability of the Lathe to cut a wide range of screw threads is one of its most valuable assets, which should be exploited to the utmost by every Lathe user, who should make it his business to become fully acquainted *by practice* with the technique of this operation. Inexperienced users often find difficulty in "picking up" the threads properly on successive cuts; this problem can, however, be entirely solved by the use

of the Thread Dial Indicator, listed amongst the additional accessories for the Lathes.

In order to prevent clothing or other articles from getting caught in the screwcutting' gears, and also to protect the gears themselves from damage, a Change Wheel Guard may be obtained as an extra, and Lathes for industrial purposes must all be so fitted.

SADDLE AND SLIDE REST ASSEMBLY

All Myford Lathes are equipped with a sliding saddle operable over the full length of the bed, and a fully compound slide rest, comprising a cross slide for traversing at right angles to the bed and a swivelling top slide equipped with a simple but rigid form of tool post. The design provides for quick and easy adjustment of the tool or slide position to deal with various types of operation, and the entire top slide can be removed in a matter of seconds, leaving the flat tee-slotted surface of the cross slide on which fixtures may be mounted for milling or other special operations, or jobs may be bolted down for boring or facing by means of rotary tools. In this respect these Lathes lend themselves readily to a wide range of out-of-the-way operations which are often impossible with much more elaborate and expensive Lathes; thus they contribute the ideal "universal" machine tool for the small workshop, where the space or available, equipment is limited.

All slides have adjustment for taking up side play by means of grub screws bearing on gib strips. The feed screws of both cross and top slides have twelve threads per inch and are operated by balanced ball handles. These screws are fitted with graduated dials having 80 divisions round the edge. Each division represents a slide movement of 0.00104 inches, which for practical purposes may be regarded as a close approximation to one-thousandth of an inch.

End play in the slide rest screws can be adjusted by means of a lock nut on the spindle behind the handle. In common with other adjustments on the Lathe, this only requires attention at rare intervals, providing that it is set properly in the first place.

To traverse the saddle rapidly along the bed, a rack and pinion gear is provided, but a more gradual hand feed motion may be obtained by the use of the lead screw, when it is not geared up to the headstock for screwcutting or automatic traversing. For this purpose the end of the lead screw may be equipped with a handle for manual operation.

TAILSTOCK

This embodies a sliding barrel fully supported throughout the full length of travel, and made hollow to enable work to pass right through it and also to facilitate ejection of the centres. The rear end of the barrel is screwed 8 t.p.i. square thread and provided with a feed handwheel knurled on the outer edge; end thrust is taken by means of a large plate on the back of the tailstock casting.

By reason of the special design of this tailstock casting it is possible to obtain a close approach of the back centre to the chuck without excessive projection of the barrel and also to operate the cross slide when fed in close to the tailstock. Although not definitely equipped with a set-over slide, an adjustment is provided on the front gib of the tailstock, whereby a sufficient cross movement of the rear centre may be obtained for adjusting parallelism of work between centres, or turning fine tapers.

To adjust the tailstock either way, the rear clamping screw should first be slackened, so as to free the soleplate from the bed; the front gib screws are then loosened and the gib adjusted by means of the two thrust screws set horizontally. Re-tighten in the reverse order.

Both 3 1/8 in. and 3 1/2 in. Lathes are equipped with a substantial form of clamp, operated by a horizontal stud with a quick action lever, and an adequate grip is obtained to hold the tailstock rigidly against any normal stresses which may be expected in a Lathe of this size.

STANDARD EQUIPMENT

Each Lathe is supplied with the following items of equipment: one faceplate of large diameter, one driver plate, one chuck backplate adapter for fitting to mandrel nose, and one pair of point centres to fit the headstock and tailstock centres respectively.

CHUCKS

These are not supplied as standard equipment, but in normal times can be fitted to Lathes before leaving the works. The following chucks are recommended: one 4-in. light type independent 4-jaw chuck (MA76), and one 3 in. or 4 in. geared scroll self-centring chuck (MA75), or alternatively, one 3 in. lever scroll self-centring chuck (MA75A).

ADDITIONAL ACCESSORIES

TRAVELLING STEADY (MA63 and 64)

This is attached to the left-hand side of the saddle at the rear of the tool post and moves with it when the saddle is traversed. It is readily adjusted to the size of work being turned and is extremely useful when turning long, slender shafts, long screws, etc. The usual tendency for the work to spring away from the tool, and for the latter to dig in or chatter, is completely eliminated by its aid, and many operations which would otherwise be almost impossible are rendered quite easy.

FIXED STEADY (MA62 and 62A)

This is of the three-point type, arranged to be clamped to the bed, and supports the outer end of long work held in the chuck by means of three adjustable contact pads. The top half of the steady frame is hinge-jointed, so that it can be opened up to enable work to be inserted or withdrawn without dismantling the steady from the Lathe bed.

For purposes such as accurately centring or drilling shafts, boring cylinders, etc., the three-point steady is almost indispensable, and in many other classes of work it can be employed so as to simplify setting up, also to ensure perfect concentricity of inside and outside machined surfaces.

HAND REST (MA69)

By substituting this fitting for the top slide, the use of hand tools for turning irregular contours or working in wood, ivory, bone, plastics, etc., is facilitated. It consists of a soleplate with a socket in which is mounted a vertical stem carrying a level topped tee rest. The height of the stem is adjustable to suit the work.

MACHINE VICE (MA71)

This can be used as an auxiliary chuck to hold work on the faceplate and will be found capable of dealing with many components which are awkward to chuck in the ordinary way. It can also be used on the cross slide or vertical slide for holding work in milling or sawing operations, and is also an extremely useful accessory for use in connection with other machine tools such as drilling machines, shaping, etc. A removable swivelling jaw is fitted to the vice to enable it to grip tapered or irregularly shaped work.

TURRET TOOL POSTS (MA66)

A four-way tool post may be fitted to the top slide in place of the normal form of tool clamp, to facilitate the repetition of complex operations. Thus four tools may be kept set up for immediate operation, and it is only necessary to unlock the turret and turn it round to bring any required tool into operation. An indexing pin is fitted to locate the turret in each tool position.

The turret is arranged to take 1/4in. square cutter bits. A quick operating clamping bolt is used, by means of which the turret may be firmly locked; the rigidity of the tools is thus in no way inferior to that provided by the normal single-way tool-holder.

THREAD DIAL INDICATOR (MA101)

The use of this appliance has already been referred to. It consists of a bracket which is readily attached to the Lathe saddle, and carries a spindle, on the lower end of which is mounted a small worm wheel which may be brought into mesh with the threads of the lead screw. When the latter is not driving the saddle (*i.e.*, when the claspnut is disengaged), this worm wheel is rotated by the lead screw, and by means of a graduated dial may be used to indicate the relation between the saddle position and the screw rotation.

In use, the claspnut is engaged when one of the numbers on the dial is in line with the index mark on the bracket. On succeeding cuts the following rule applies: For all even numbers of threads per inch, the clasp nut may be engaged on any number.

For odd numbers of threads, engage either at the original number or any *alternate* number.

For half or quarter threads per inch, always engage at the same number.

VERTICAL SLIDES (MA67 and 68)

Milling operations are greatly facilitated by these components, which are mounted on the cross slide. Work clamped thereto may thus be adjusted in a vertical direction. In conjunction with the other slide movements, three-dimensional adjustment of the work becomes possible, so that it may be operated on by a milling cutter with the same facility as that provided by a milling machine. A vertical slide may also be used for mounting a milling, drilling or grinding spindle, for operations by means of overhead gear or by a separate motor.

Two types of vertical slide are available; the simpler type (MA67) has the slide fixed to travel in a vertical direction only, but the swivelling type (MA68) may be adjusted to any required angle and swivels in both horizontal and vertical planes.

ANGLE PLATE (MA73 and 74)

Sooner or later an angle plate will be required by every Lathe user, for setting up awkward jobs on the faceplate or vertical slide. An inexpensive type, specially suitable for use with Myford Lathes, is available. The bolting faces and edges are accurately machined to a true right angle, and slots are provided for bolts to mount the angle plate and clamp the work.

VEE BLOCKS (MA70)

These are also indispensable for many jobs on the Lathe and other machine tools. The type supplied for use with Myford Lathes is equally adaptable for mounting work either on the faceplate, cross slide or vertical slide, and the design facilitates clamping without impairing accessibility.

EXTRA CHANGE WHEELS

Duplicates of any change wheels in the standard sets may be supplied on request, also additional wheels Nos. 38, 64, 70, 75, 80, 85, 90, 95, 100 and 127 teeth. These may be used to extend the range of threads or fine feeds. An extra 20-tooth wheel is particularly useful for setting up a fine feed train.

GUARANTEE

Every possible care is taken to ensure that both the material and workmanship in Myford Lathes are sound. Components which are found on examination to be faulty will be corrected or a replacement part supplied free of cost at our works. It is in the sender's interest to ensure that any part returned is clearly labelled with the sender's name and address, date of purchase and supplier; otherwise, no responsibility can be "accepted.

The Myford policy is one of constant progress and improvement and suggestions from Lathe users for improving and increasing the range and utility are always welcomed. Advice is freely given by the Technical Department on all matters pertaining to the use of Myford Lathes.

HOW TO GET THE BEST SERVICE FROM YOUR MYFORD LATHE

Always keep Lathe Tools keen and properly set at the appropriate rake of clearance for the material being turned. As a general rule, set cutting edge of tool dead level with Lathe centres. Chattering and digging-in are caused by incorrect tool setting, inadequate support of tool or work, or too wide a cutting edge.

Do not expect a light Lathe to take very heavy cuts. Myford Lathes have a remarkable capacity for work if used with discretion, but attempts to force the rate of cutting will only strain the Lathe Mandrel and Slides, without speeding up output to any extent. Use feed and speed best suited to diameter of work and nature of material. Rough castings, or work in which the cut is intermittent, demand a substantial reduction of speed as compared with plain circular turning of round stock. Do not hold rough or irregularly-shaped work in a self-centring Chuck. Do not attempt to set work true with a hammer after the Chuck has been tightened. Offset work mounted on the Faceplate should always be counter-weighted to run in correct balance, be supported by the Back Centre or Fixed Steady. Excessive overhang of work from the Chuck should be avoided, especially when parting-off.

Keep working parts clean, free from swarf and properly lubricated. With work of an abrasive nature (grinding or lapping) prevent abrasive dust from entering slides or bearings, and thoroughly clean the Lathe afterwards. A film of oil on all bright parts will keep them free from rust, but if rust spots appear, do not clean them off with emery; the initial rust film, if its progress is arrested, will form a protective coating, and apart from the matter of appearance, will do no further harm. If things go wrong in machining, do not jump to the conclusion that the Lathe is at fault. The best Lathe will produce bad work if not skilfully handled. Errors in circular accuracy, parallelism, etc., of turned work are susceptible to correction by careful adjustment of Lathe bearings and slides. Slide gibs should allow work to move freely, but without play, for normal work; heavier work, such as parting-off, screwcutting, etc., may call for somewhat tighter adjustment of slides, and milling requires fairly tight slides. The truth of the Mandrel centre should be checked before turning work between centres, and if incorrect, the cause investigated and corrected. Keep the back centre well lubricated when in use, and so adjusted as just to eliminate end play.

TREAT YOUR LATHE AS A FRIEND—NOT AS A MEANS
TO AN END

SCREW CUTTING TABLE.

NOTE.--

Two collars provided are to be used on the Mandrel and Leadscrew respectively.

A small piece of 3/32in. steel wire should be used to connect two wheels together on one stud when compounding trains of wheels.

Whitworth

Threads.	Mandrel	1st Stud.		2nd Stud.		Lead Screw
9	40	Idle Wheel		Idle Wheel		45
10	40	"		"		50
11	40	"		"		55
12	40	"		"		60
14	20	"		"		35
16	20	"		"		40
18	20	"		"		45
20	20	"		"		50
22	20	"		"		55
24	20	"		"		60
25	20	"		25	20	50
26	20	"		"		65
28	30	"		35	20	60
32	30	"		40	20	60
36	30	"		45	20	60
40	30	"		50	20	60
Fine Feeds		Driven Driver				
114.4	20	55	30	60	25	65
171.6	20	55	25	60	20	65

N.B.—Extra 20 Gear required for thread 171.6.

Metric

Pitch M/M	Equiv- alent in T.P.I.	Nearest Set Up	Man- drel Driver	1st Stud		2nd Stud		Lead- screw
				Driven	Driver	Driven	Driver	
.75	33.860	33.846	30	60	65	50	20	55
1.00	25.400	25.385	65	30	20	50	20	55
1.25	20.320	20.310	20	idle wheel		60	65	55
1.50	16.930	16.923	20	"	"	55	65	50
1.75	14.514	14.545	30	"	"	60	55	50
2.00	12.700	12.727	20	"	"	50	55	35
2.25	11.280	11.256	30	"	"	55	65	50
2.50	10.160	10.154	40	"	"	60	65	55
2.75	9.237	9.231	40	"	"	60	65	50
3.00	8.460	8.461	40	"	"	50	65	55

N.B.—Extra 20 Gear required for 1.00 Metric Pitch.

The second column shows the exact number of threads per inch for the corresponding metric pitch, whereas the third column shows the threads per inch obtained by this set up, which is near enough for most practical purposes.

SCREW CUTTING and FINE FEED CHART

for ML7, ML7-R and SUPER-7 LATHES (Leadscrew-8 T.P.I.)

INCH PITCHES

T. P. I.	FEED PER REV.	DRIVER	1 ST STUD		2 ND STUD		LEAD SCREW	SET-UP
			DRIVEN	DRIVER	DRIVEN	DRIVER		
8	.1250"	20	IDLE 75 WHEEL	---	---	---	20	1
9	.1111"	40	IDLE 60 WHEEL	---	---	---	45	1
10	.1000"	40	IDLE 60 WHEEL	---	---	---	50	1
11	.0909"	40	IDLE 60 WHEEL	---	---	---	55	1
12	.0833"	40	IDLE 50 WHEEL	---	---	---	60	1
14	.0714"	20	IDLE 70 WHEEL	---	---	---	35	1
16	.0625"	20	IDLE 70 WHEEL	---	---	---	40	1
18	.0556"	20	IDLE 70 WHEEL	---	---	---	45	1
19	.0526"	40	38	20	IDLE 55 WHEEL	---	50	2
20	.0500"	20	IDLE 70 WHEEL	---	---	---	50	1
22	.0455"	20	IDLE 70 WHEEL	---	---	---	55	1
24	.0417"	20	IDLE 70 WHEEL	---	---	---	60	1
25	.0400"	40	50	30	IDLE 45 WHEEL	---	75	2
26	.0385"	20	IDLE 70 WHEEL	---	---	---	65	1
28	.0357"	30	35	20	IDLE 50 WHEEL	---	60	2
32	.0313"	30	40	20	IDLE 55 WHEEL	---	60	2
36	.0278"	30	45	20	IDLE 55 WHEEL	---	60	2
40	.0250"	30	50	20	IDLE 55 WHEEL	---	60	2
44	.0227"	20	55	30	IDLE 50 WHEEL	---	60	2
46	.0217"	20	46*	30	IDLE 45 WHEEL	---	75	2
48	.0208"	20	60	35	IDLE 45 WHEEL	---	70	2
52	.0192"	20	50	25	IDLE 55 WHEEL	---	65	2
54	.0185"	20	45	20	IDLE 55 WHEEL	---	60	2
60	.0167"	20	50	25	IDLE 55 WHEEL	---	75	2
64	.0156"	35	40	20	60	30	70	3
72	.0139"	25	50	30	45	20	60	3
80	.0125"	25	50	35	70	30	75	3
88	.0114"	30	40	25	55	20	75	3
92	.0109"	20	46*	30	50	20	60	3
96	.0104"	30	40	20	60	25	75	3
104	.0096"	20	50	30	60	25	65	3
	.0087"	20	55	30	60	25	65	3
112	.0089"	25	50	30	60	20	70	3
120	.0083"	20	50	30	60	25	75	3
	.0058"	20	55	25	60	20	65	3
	.0043"	20	60	25	65	20	75	3
	.0037"	20	65	25	70	20	75	3
	.0018"	12*	65	20	70	20	75	3

METRIC PITCHES

FEED PER REV. MILLIMETERS	DRIVER	1 ST STUD		2 ND STUD		LEAD SCREW	SET-UP
		DRIVEN	DRIVER	DRIVEN	DRIVER		
0.20	21*	50	30	60	21*	70	3
0.25	30	40	21	60	21	70	3
0.30	21	60	45	50	21	70	3
0.35	35	40	21	50	21	70	3
0.40	21	50	21	IDLE 60 WHEEL	---	70	2
0.45	45	40	21	50	21	70	3
0.50	21	50	45	40	20	60	3
0.60	21	50	45	40	30	75	3
0.70	21	50	21	IDLE 60 WHEEL	---	40	2
0.75	45	40	35	50	21	70	3
0.80	21	50	45	IDLE 40 WHEEL	---	75	2
0.90	45	25	21	40	21	70	3
1.00	45	40	21	IDLE 50 WHEEL	---	75	2
1.10	45	50	55	40	21	75	3
1.20	45	25	30	50	21	60	3
1.25	45	40	21	IDLE 50 WHEEL	---	60	2
1.30	65	25	21	40	21	70	3
1.40	45	25	35	50	21	60	3
1.50	21	50	45	IDLE 35 WHEEL	---	40	2
1.60	45	25	21	IDLE 55 WHEEL	---	75	2
1.75	45	20	35	50	21	60	3
1.80	30	40	45	25	21	50	3
2.00	60	40	21	IDLE 55 WHEEL	---	50	2
2.25	45	40	60	40*	21	50	3
2.50	45	30	21	IDLE 50 WHEEL	---	40	2
2.75	55	20	30	40	21	50	3
3.00	45	25	21	IDLE 60 WHEEL	---	40	2
3.50	60	20	35	40	21	50	3

● Not a Standard Gear. Available as an extra.

★ 12 tooth Tumbler Cluster Gear available as an extra.

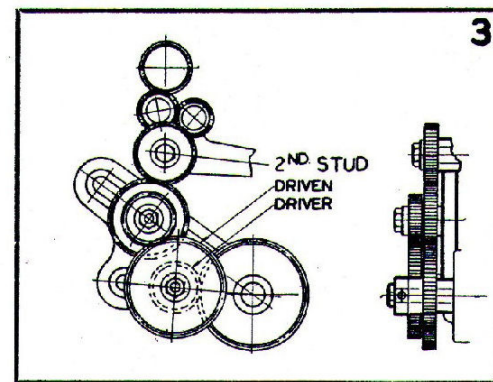
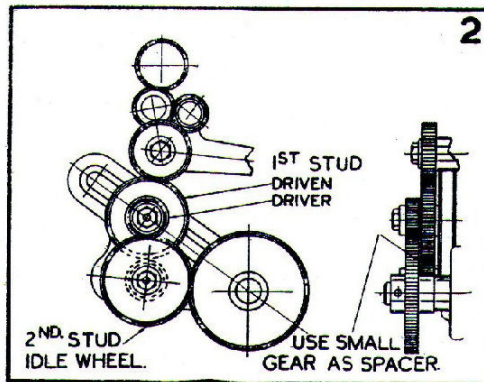
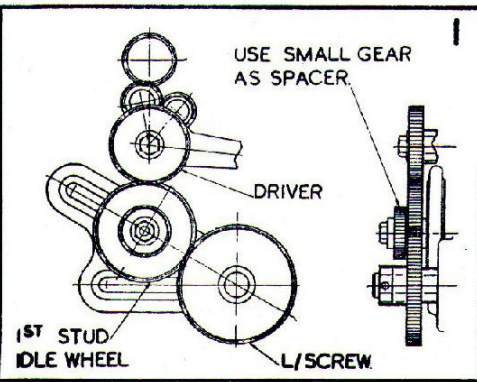

THE GEAR TRAIN

When setting up the gear train be sure to allow sufficient clearance between each pair of meshing gears. When the lathe is in operation the play in the gears is automatically taken up according to the direction of travel; the amount of gear clearance does not influence the accuracy of thread cutting. Gear noise can be reduced by the application of grease, preferably graphited, or a special grease such as Rocol MTS 1000.

THE TUMBLER REVERSE

It is important that the tumbler gear lever is not shifted during thread cutting operations, as such movement may alter the relative position of the headstock spindle to the leadscrew, thereby causing split threads.

CHANGE-WHEELS, Standard Set

20T. 20T. 25T. 30T. 35T. 38T. 40T. 45T. 50T. 55T. 60T. 65T. 70T. 75T.

THE IDLE WHEEL

USED IN SET-UPS **1** AND **2** MAY BE ANY CONVENIENT SIZE.

THEY HAVE NO EQUAL

3 $\frac{1}{8}$ —3 $\frac{1}{2}$ BACK GEARED & SCREW CUTTING

MYFORD LATHES

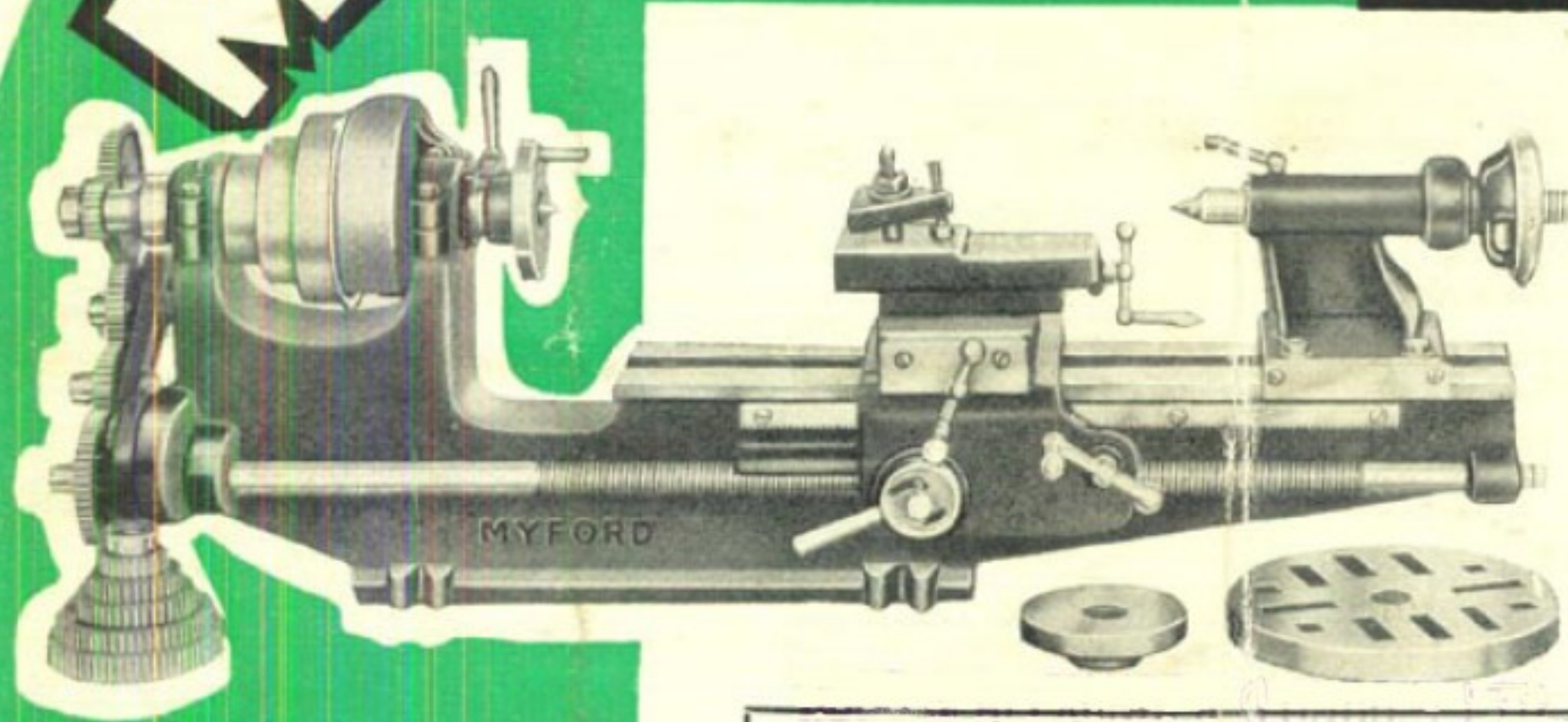

167, BISHOPSGATE,
LONDON, E.C.2.

ELECTRIC MOTORS.

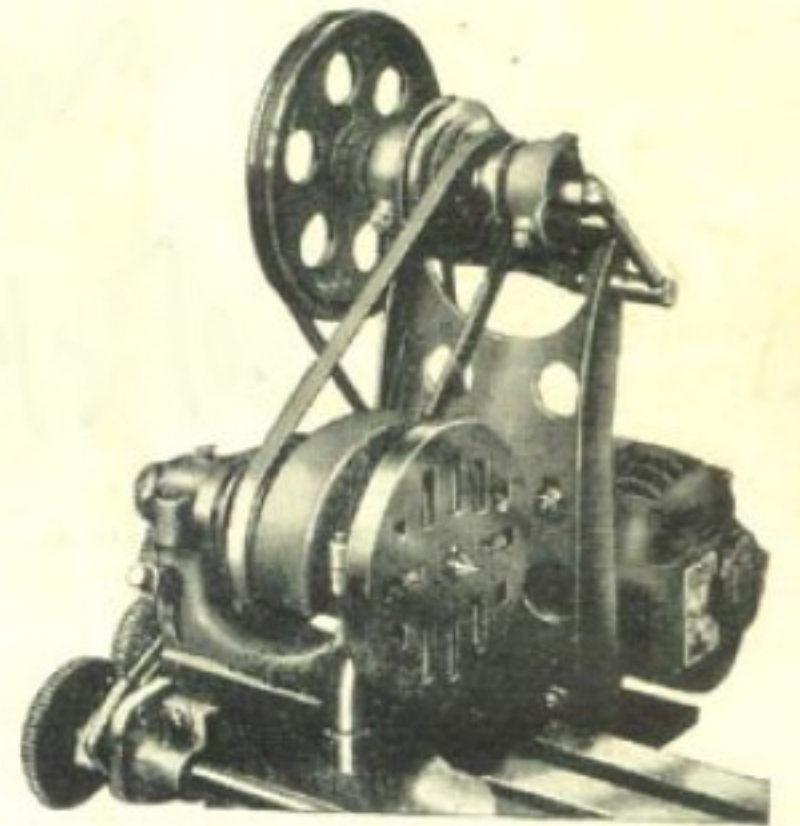

ACCESSORIES

TREADLES, FOOT MOTORS
CHUCKS, SLIDES, ETC., ETC.
A LARGE RANGE.

MYFORD

MOTORISED UNITS
BENCH & STAND
TYPES.



We have pleasure in introducing the latest range of $3\frac{1}{8}$ " and $3\frac{1}{2}$ " Lathes from the Myford Factory.

These machines are designed and manufactured upon the latest principles and can be safely relied upon to give years of hard service, their sturdiness and accuracy ensuring highly satisfactory usage up to the limits of their capacity.

Myford Lathes are equally suitable for turning Cast Iron, Steel, Bronze, Brass or Wood and operations such as Drilling, Boring, Reaming, Surfacing, Screw-cutting, Gear Cutting, Taper turning, etc., can be readily accomplished in these metals and also in similar materials.

Our Policy is one of progressive improvement, and perhaps the most important feature to customers is that we regard the giving of the utmost possible value as of prime importance.

We are confident that no better value exists.

A further point of policy is that we ensure wide distribution and also maintain a comprehensive and ever increasing range of inexpensive and well-designed Accessories.

This latter point will be appreciated by those who have purchased lathes, and have found difficulty in obtaining Accessories suitable to their particular requirements.

We have made many friends of satisfied users in all parts of the World, and Myford Lathes have been supplied to Government Depts., including the G.P.O., Radio Stations, Technical Schools, Aircraft and Submarine Works, and many hundreds of Production Works and Garages.

Amongst the vast number of private users are Model Engineers, Mechanics, Doctors, Dentists and many others who delight in the turning of Metals as a leisure hour occupation.

The many thousands of Myford Lathes which are giving pleasure prove that the Myford Lathe and the Myford Policy will give you satisfaction and service.

We therefore offer these lathes with every confidence, and you are assured of the utmost satisfaction. Should any part prove faulty it will be replaced free of charge.

ADVANTAGES OF THE MYFORD DESIGN



HEADSTOCK AND BED.—The foundation of any lathe is the bed, weak design here will result in indifferent work on a weak Tool. Myford Lathes are renowned for their heavy box beds. The webs are also positioned to ensure the utmost rigidity. Selected Iron is used, and fully "matured" before and between machining operations. The beds can be relied upon to withstand heavy cuts without the slightest "spring."

The Headstock also is of massive design, the heavy and long bearings are adjustable and carry a large diameter Mandrel.

MANDRELS.—Are ground to gauged limits, using the Taper Socket as a means of location, thus perfect Mandrels with barrel and Chuck register concentric with taper to .0005" limits result. Tumbler Reverse Lathes can also be supplied with large Mandrel, No. 2 Taper as an extra.

COMPOUND SLIDE REST.—A strong lathe demands a good slide rest. The Myford slide is well proportioned, has good bearing surfaces, adjustable gibs, square thread feed screws with end thrust adjustment. Ball handles are a refinement giving that delicate feel which a wheel cannot equal. All Slides are hand scraped and fitted only by experienced slide fitters. The long Cross Slide on large Saddle helps when taking heavy cuts. The machined Tee Slots are so spaced as to accommodate large boring jobs.

BACK GEAR.—You will appreciate the convenience of this. The design is sturdy and peculiar to Myford. Moreover it is "well proved," having given satisfaction to thousands of users.

THE TOP SLIDE which is indexed, has a swivelling movement and is very robust in design. Long traverse is obtained on both slides. Square threads with Thrust adjustment and Vee Strips are used throughout.

RACK AND PINION.—The Steel Rack and Pinion as fitted to all Myford Lathes is a necessity for rapid operation of a lathe, and will speed up all Turning, Screwcutting and Boring operations. The Leadscrew guard will really save your leadscrew from the wear and tear that arises from Cast Iron turnings, etc., but please do oil the leadscrew.

AUTOMATIC TRAVERSE.—The Double Clasp Nut in Vee Slide is a new and unusual feature in this size lathe. A refinement is found in the reversing fork which gives quick change to right or left hand in screwcutting, etc.

TUMBLER REVERSE is also available as an extra. A Ball Handle is readily fitted to the lead screw when specified at a small extra cost.

TAILSTOCK is of over-hung type to clear the Top slide handle. Parallel set over movement is provided for taper turning, and accurate alignment is controlled by Thrust Screws operating on moveable Gib.

PULLEYS.—These are **crowned** to ensure good grip and true alignment of belt.

VEE BELT DRIVE.—Available as an alternative.

EQUIPMENT.—You will appreciate the completeness of Myford equipment—this comprises:

- (A) Full set of 10 Change Wheels (machined from solid).
- (B) Chuck Backplate.
- (C) Face Plate—exceptionally heavy—no "Spring."
- (D) Catch Plate.
- (E) Centres of Tool Steel for Headstock and Tailstock.

FINISH.—Myford Blue/Grey and Red, all bright parts polished. We take a pride in sending these machines out in fitted cases of standardised design, with the certainty that they will arrive safely and give the user every satisfaction.

POWERING.—You will find available: Footmotors, Stand and Treadle.

Motorised Stands (for those with electricity).

Power Countershafts (for drive off existing line shafts).

Motor and Unit Type of C/S for either bench, wall or overhead fixing.

SERVICE.—We shall at all times be glad to be of assistance to Lathe users, whatsoever type they may use, and are only too pleased to advise on all matters appertaining to Lathe practice.



3½ inch LATHES, 8½ inch Swing, 15 inch Capacity

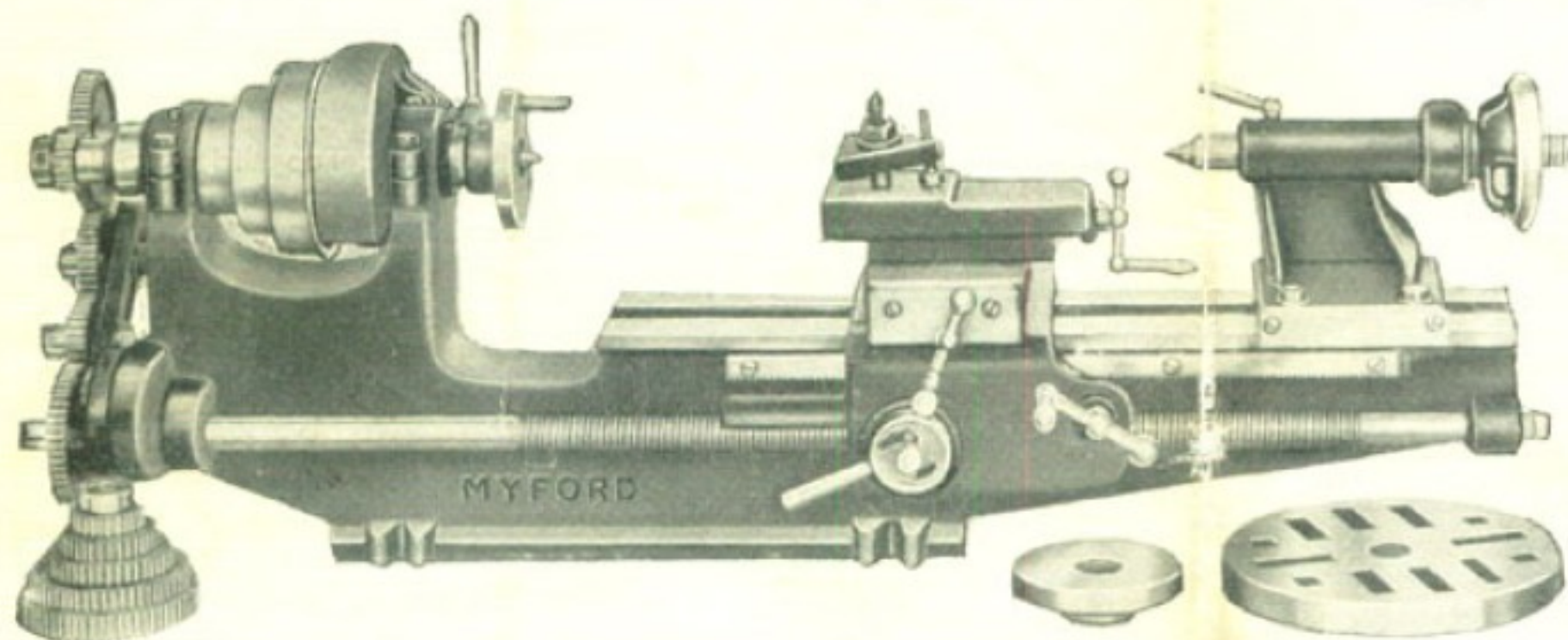

STANDARD MODEL

TYPE ML.1

The Standard Lathe, illustrated above, made the Myford name.

It has no equal for sturdiness and value.

Equipped as illustrated.

Price: £7 0 0 ex Works.

Extras—Tumbler Reverse 10/-, if with No. 2 MT. Mandrel, 3/8 in. bore, 25/-.

Thread Dial Indicator 10/-, Vee Rope H/Stock Pulley 2/6.

Change Wheel Guard 7/6. Strong fitted Cases (returnable) 10/6.

SUPERIOR MODEL

TYPE 'S'.2

Superior Specification includes Shrouded Ball Thrust to Mandrel, High-grade Phosphor Bronze Bushes in Headstock bearings, Long Cross Slide and Quick Release Tailstock.

Equipped as illustrated.

Price: £8 5 0 ex Works.

DIMENSIONS

Centre Height	3½"
Length between Centres	15"
Swing over Saddle	4½"
Swing In Gap	8½"
Dia. of Mandrel	1"
Dia. of Mandrel Nose ...	7/8" Whit.
Mandrel and Tailstock	
Bored	3/8" Clear
Centres— No. 1 MT Taper	
Cross Slide Traverse ...	3¼"
Do. (Superior Model) ...	4½"
Top Slide Traverse	2¾"
Lead Screw	Dia. 3/8" x 8T.P.I.
Face-Plate	6¼" Dia.
T.S. Barrel Travel	3"
Cone Pulley (3/8" Belt)	
	Dia. 2¾", 3¼", 3¾"
Back Gear Ratio	6 to 1 approx.



3½ LATHES, 10 inch Swing, 24 inch Capacity

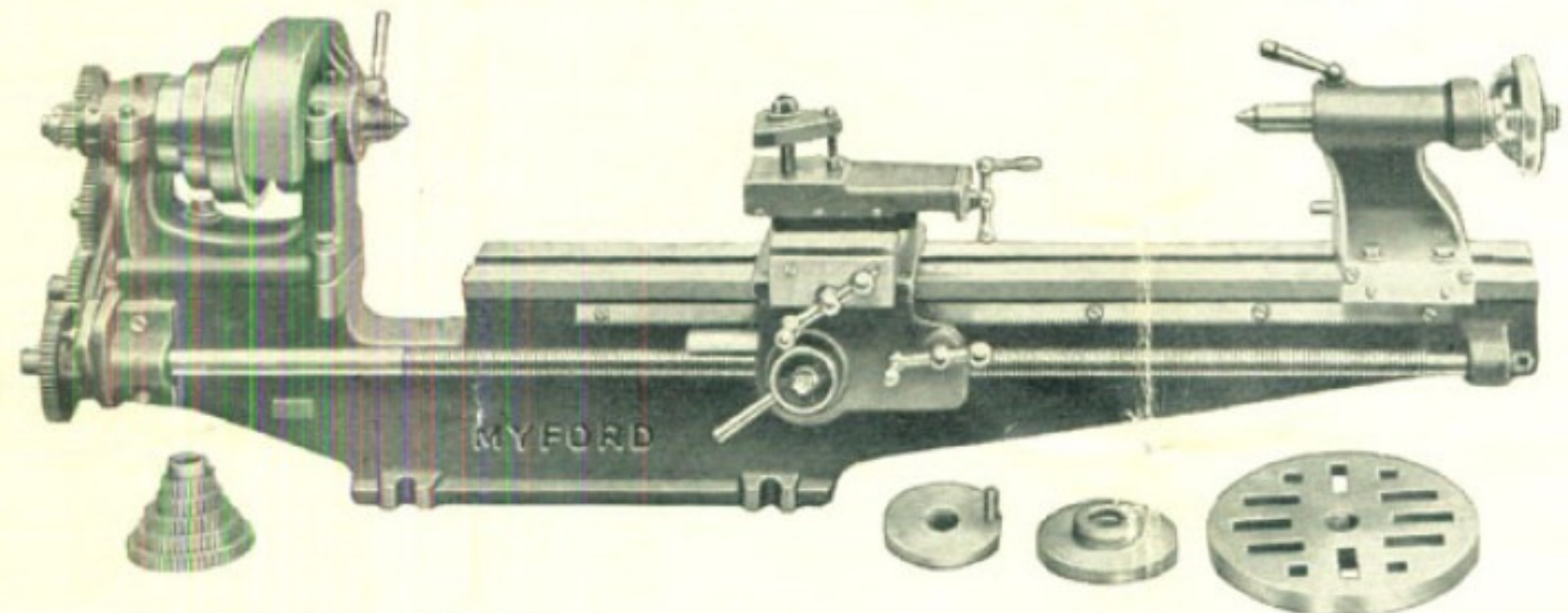

DIMENSIONS

Centre Height	3½"
Capacity between Centres	24"
Swing over Saddle	5½"
Swing in Gap.	10"
Diameter of Mandrel ...	1"
Diameter of Mandrel Nose	⅞" Whit.
Mandrel Tailstock	
Barrel Bored	⅜" Clear
Centres	No. 1 Morse Taper
Cross Slide Traverse	
(Ord.)	3¼"
Cross Slide Traverse	
(Long)	4½"
Top Slide Traverse	2½"
Lead Screw Diameter ...	⅝"
Lead Screw Pitch	8 T.P. 1
Face Plate	6¼" Dia.
T.S. Barrel Travel	3"
Dia. of 3 Speed Cone	
	2⅜", 3⅛", 3⅞"
Width of Belt	¾"
2 Speed Cone for 1" Belt optional.	
Overall Length	39"

STANDARD MODEL

TYPE ML.3

Introduced later, this model is rapidly becoming a great favourite. Whilst increasing the capacity enormously we have not neglected to retain the vital sturdiness of the smaller lathe.

Equipped as illustrated.

Price : £9 10 0 ex Works.
(Long Cross Slide, extra).

SUPERIOR MODEL

TYPE ML.4

The Superior specification includes Shrouded Ball Thrust to Mandrel, High-grade Phosphor Bronze Bushes in Headstock Bearings, Long Cross Slide and Quick Release Tailstock.

Equipped as illustrated.

Price : £10 9 0 ex Works.

Extras—Tumbler Reverse 10/-, if with No. 2 MT. Mandrel, ⅝in. bore, 25/-.
Thread Dial Indicator 10/-, Vee Rope H/Stock Pulley 2/6.
Change Wheel Guard 7/6. Strong fitted Cases (returnable) 13/6.



ACCESSORIES

Serial Nos.	£	s.	d.
MA-51—Stand and Treadle—With Special Broad Malleable Iron Treadle for 3½ in. Lathe...	4	12	6
MA-52—Stand and Treadle—With Special Broad Malleable Iron Treadle for 3½ in. Lathe ...	5	4	6
MA-53—Stand and Treadle—Malleable Iron Pedal for 3½ in. Lathe ...	4	8	0
MA-54—Stand and Treadle—Malleable Iron Pedal for 3½ in. Lathe ...	5	0	0
MA-55—Stand Only for 3½ in. Lathe ...	3	0	0
MA-56—Stand Only for 3½ in. Lathe ...	3	8	6
MA-57—Best Quality ¾ in. Leather Belt—Fitted ...		4	0
MA-58—Foot Motor—Malleable Iron Pedal ...	2	1	6
MA-58a—Foot Motor—Very heavy type with 56lb. Flywheel ...	2	11	0
MA-59—Heavy Power C/Shaft with Adjustable Swivel Bearings ...	1	12	0
MA-59a—Power Countershaft with extra heavy brackets, 8in. fast and loose pulleys, and striking gear ...	2	0	0
MA-60—Motor Countershaft ...	1	12	0
MA-61—One Unit Motor C/S—Suitable for bench, wall or overhead (state position) ...	1	12	0
MA-62—Fixed Steady—Hinged Type, for 3½ Lathe ...	16	6	
MA-62a— do. for 3½ in. Lathe ...	17	0	
MA-63—Travelling Steady for 3½ in. Lathe ...	11	0	
MA-64— do. do. for 3½ in. Lathe ...	12	0	
MA-65—4 Tool Turret ...	7	3	
MA-66—4 Tool Turret with Locating Plunger & Lever ...	11	0	
MA-66a—6 Tool Turret for Round Tools (½ in. dia.) ...	7	3	
MA-67—Vertical Slide ...	1	4	9
MA-68—Vertical Slide, Swivelling type ...	2	1	3

ACCESSORIES

Serial Nos.	£	s.	d.
MA-69—Hand Rest ...		6	6
MA-70—Angle Plate ...		3	0
MA-71—Machine Vice ...		8	3
MA-72—Extra 20 Tooth Gear ...		2	3
MA-73—Vee Block, 3" x 1½" x 1½" ...		2	9
MA-74— do. Larger Size, 4" x 2" x 1½" ...		3	9
MA-75—3in. 3 Jaw S.C. Chucks—Fitted to Backplate	1	19	6
MA75a—3in. Lever Scroll S/C Chuck fitted to Backplate ...	1	17	6
MA-76—4in. 4 Jaw Ind. Chucks—Fitted to Backplate	1	12	0
MA-77—Wood Prong Centre (No. 1 Morse Taper)		2	9
MA-78—¾ in. Drill Chuck (No. 1 Morse Taper Shank)		3	9
MA-79—Sets of 8 High Speed Lathe Tools ...		12	6
MA-80—Motorised Stand Unit for 3½ in. Lathe ...	5	5	0
MA-81— do. do. do. for 3½ in. Lathe ...	5	13	6
MA-82—Saw Table for Wood or Metal with 4in. Saw and Spindle ...	2	2	0
MA-83—Motor Pulleys, 1½ in. dia. x ½ in. bore (correctly Crowned) ...		4	0
MA-83a—Motor Pulleys, 1½ in. x 2½ in. flat (for MA-59a)	5	0	
MA-84—Drill Pad Plain No. 1 MT Shank ...		3	0
MA-84a—Vee Drill Pad Plain No. 1 MT Shank ...		3	0
MA-84b— do. do. Revolving head No. 1 MT Shank ...		5	0
MA-84c—Drill Pad with Woodscrew Drive, No. 1 MT Shank ...		3	0
MA-85—Lathe Carriers, ½", ¾", 1". Prices: 1/2, 1/5, 1/8			
MA-86—Face Plate Dogs, 2½ in., Sets of 4 ...		1	3
MA-87—Lathe Centres—Tool Steel—each ...		1	6
MA-88—Hollow Centres ...		1	6
MA-89—Extra 3 Step Cone Pulleys, ¾" and 1" bore		5	6
MA-89a— do. for Vee Rope do. do.		8	0

ALL PRICES ARE EX WORKS.



ACCESSORIES

Serial Nos.	£	s.	d.
MA-90—Change Wheels, Nos. 25 to 100 (in increments of 5), also Nos. 38, 64 & 127 ...			0
Single Wheels, from 2/3 upwards			0
MA-91—Draw-in Collet Chucks and Collets ...			0
MA-93—Ball Handle for Leadscrew (3 1/8") 1/9 (3 1/2")	2	0	
MA-94a—1 1/8" Die Holders No. 1 MT Shank	4	0	
MA-94b—1" do. do.	5	0	
MA-94c—1 1/8" do. Sliding head No. 1 MT Shank	6	0	
MA-94d—1" do. Sliding head No. 1 MT Shank	7	6	
MA-95—Finished Backplates 3 1/2" dia. ...	4	3	
MA-95a— " " 4 1/2" dia. ...	5	6	
MA-96—Chuck Adaptor, No. 1 MT Shank	5	0	
MA-98—1/2" Collet Attachment with 1 Collet	45	0	
Collets 1/8", 1/4", 3/8", 1/2", 5/8", each	12	6	
Finished Backplates, fitted optional	4	6	
MA-99—5/8" Collet Attachment with 1 Collet	85	0	
Collets 1/8", 1/4", 3/8", 1/2", 5/8", each	15	0	
Finished Backplates, fitted optional	6	6	
MA-100—Chrome Vanadium Thin D.E. Spanners. Set of two suitable for Lathe ...	2	8	

ELECTRIC MOTORS—B.T.H., Higgs, Best British, and Continental types—Price 37/6 upwards.

⊙ Prices on application.

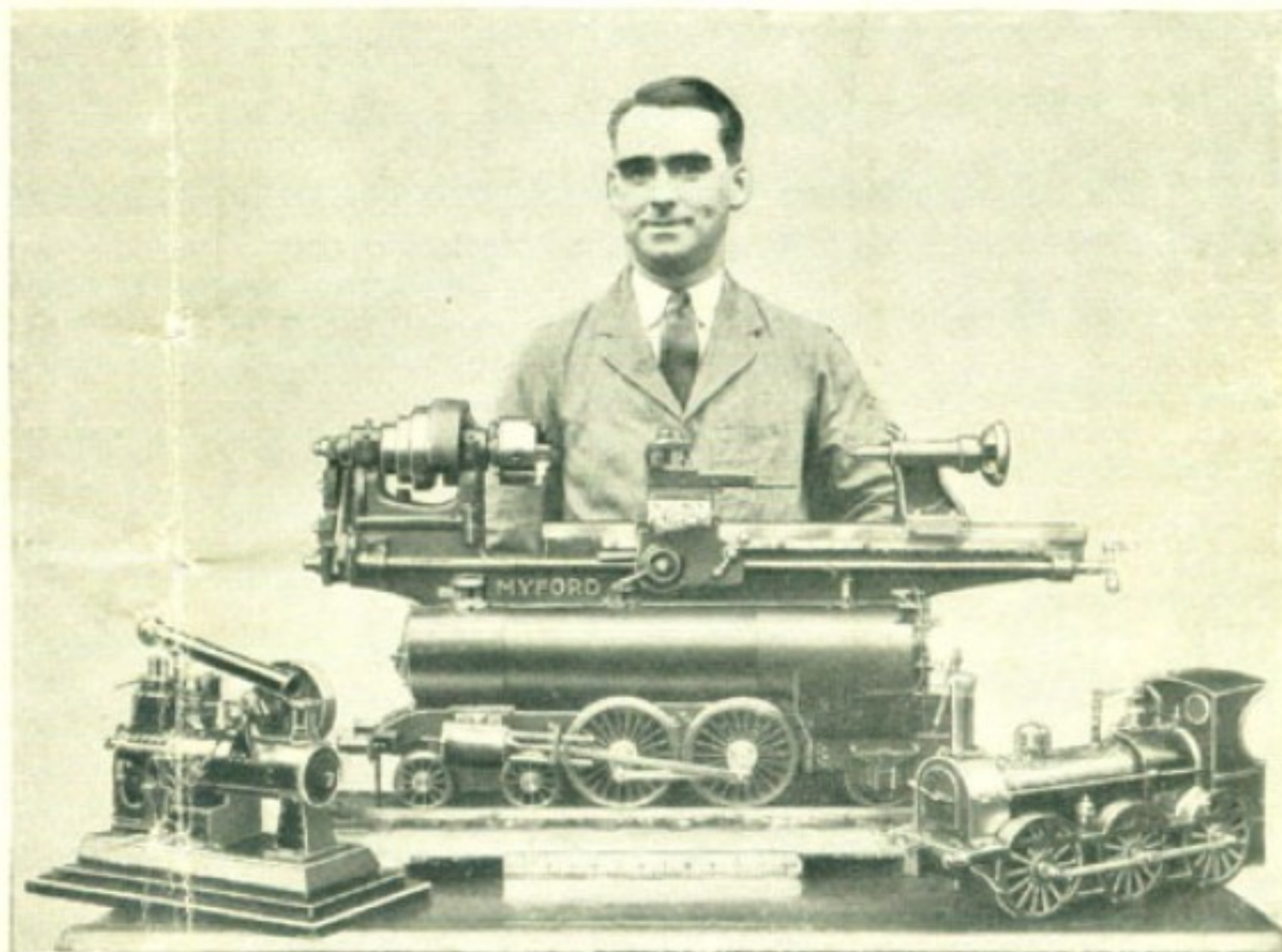

Pride of ownership is fully expressed here. This gentleman is unbiassed and sincere in his remarks that the Myford has no equal. The unique and ever increasing range of Accessories designed for these lathes is an inducement to the man who values completeness. This point will be fully appreciated by those who have in the past experienced difficulty in obtaining accessories suitable for their purpose.

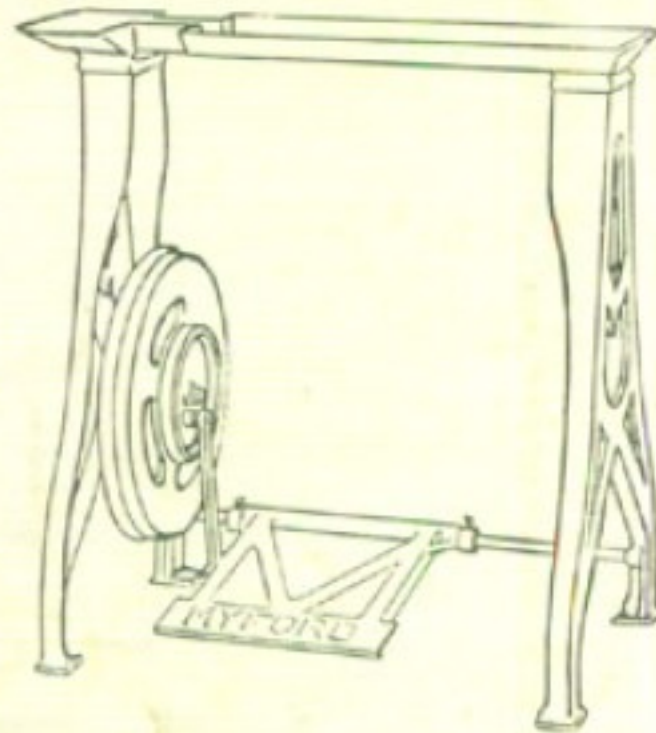

STAND and TREADLE MA-51 & 52

Roomy and deep Chip Tray. Substantial legs with wide spread to the feet. Heavy balanced Fly-wheel. Malleable Iron Treadle (practically unbreakable). With Pedal as on Foot Motor if required (see MA-53 & 54). Case 10/- returnable.

FOOT-MOTOR MA-58

Heavy Balanced Wheel. Substantial bracket and malleable Iron Pedal. Case 5/- returnable. Very Heavy Type available (see MA-58a).

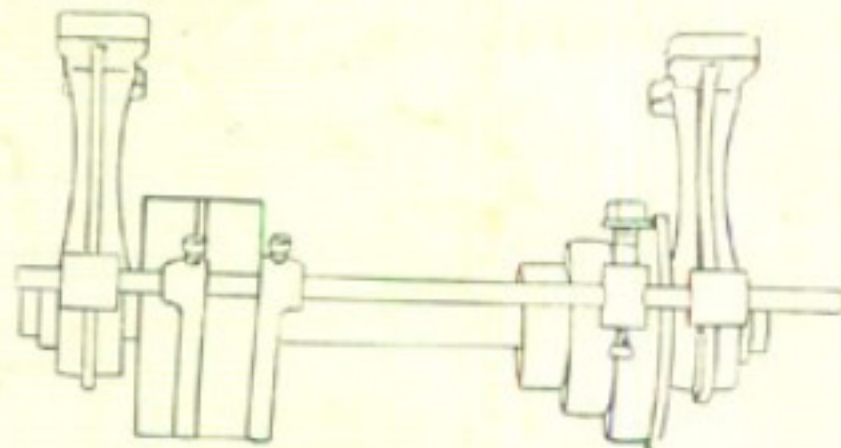
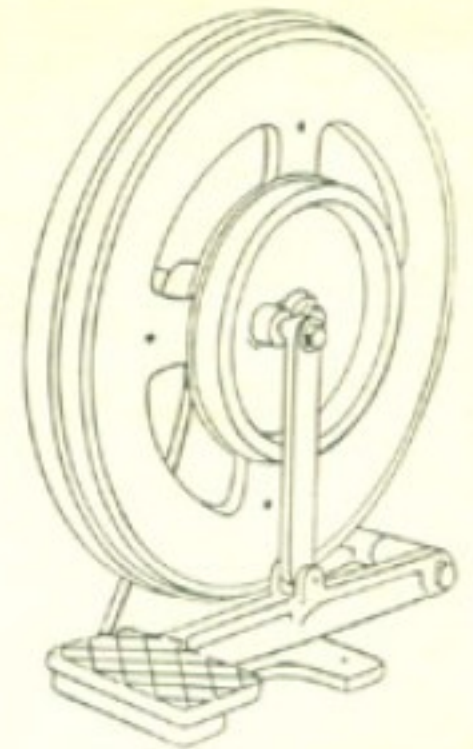

POWER COUNTERSHAFT MA-59

Substantial Hangers with self aligning bearings. 4" x 1" fast and loose pulleys. 3 speed Cone as on Lathe. Complete with Striking Gear.

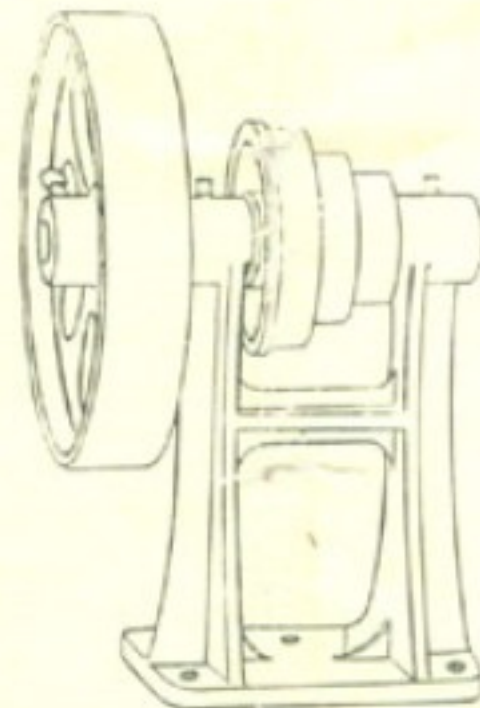

UNIT COUNTERSHAFT MA-61

Primarily for the bench and is fitted with lubricators for this position. Can be supplied for wall or overhead if required.

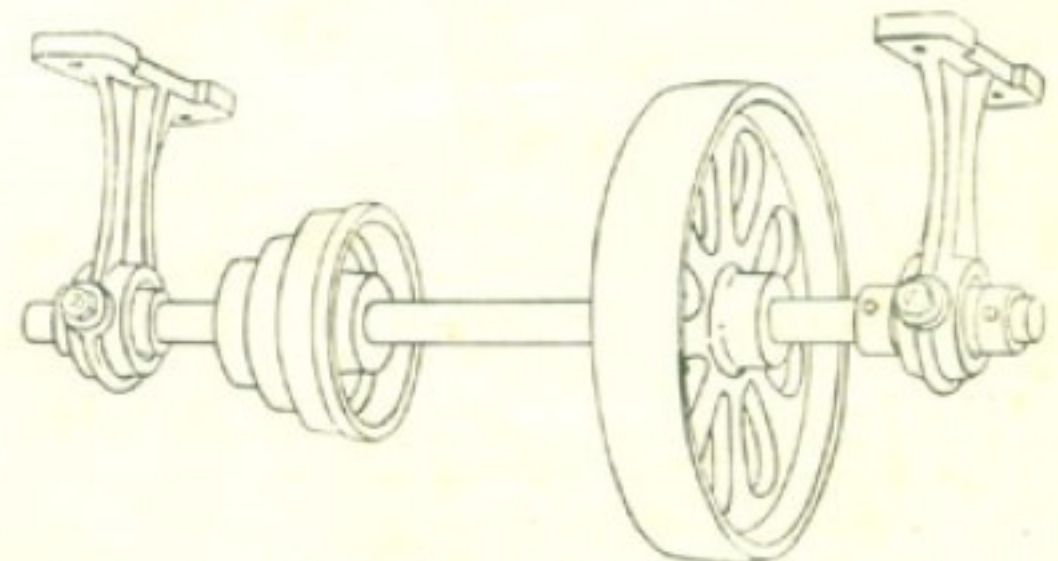

MOTOR COUNTERSHAFT MA-60

8" x 1 3/8" Crowned Motor Pulley with cone pulley as on lathe. Long shaft to accommodate Grinder Pulley. Self aligning bearings in strong hangers. Correctly Crowned Pulley for Motor shaft, 1/2" or 5/8" Bore (see MA-83).



FIXED STEADY

MA-62 & 62a

A Sturdy accessory Hinged for production work.

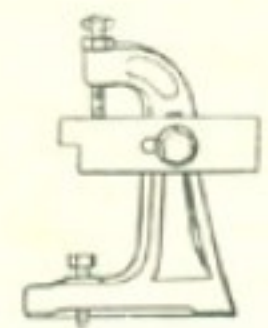

TRAVELLING STEADY

MA-63 & 64

Indispensable for all slender work. Easily fitted and adjusted.

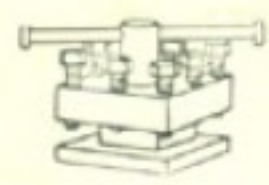

4 TOOL TURRETS

MA-65 & 66

Designed for repetition work. These Turrets take 2" x 1/4" cutters.

Do. with Locating Plunger and Quick Release Lever, MA-66.



SMALL MACHINE VICE

MA-71

Hardened thrust screw. A loose Slip is provided for holding Taper work. Can be attached to Cross Slide, Vertical Slide and Faceplate

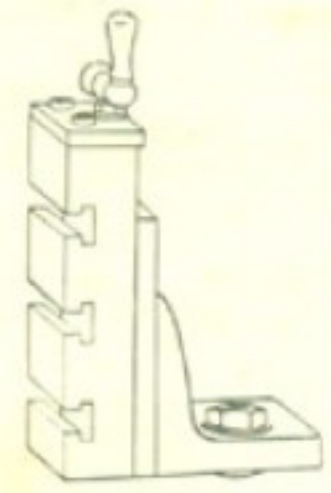

Vertical MILLING SLIDE

MA-67

Vertical Movement only. Table with machine cut slots. Table 5 1/4" x 2 3/4". Travel 3 1/4".

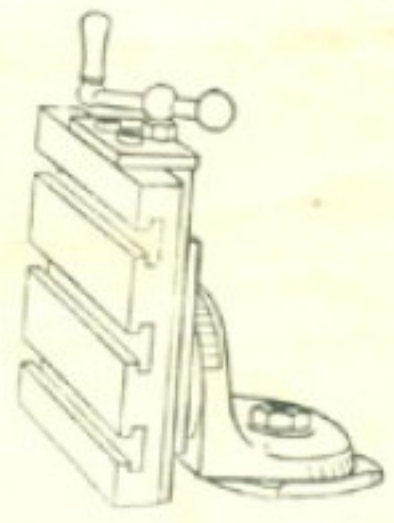

Swivelling Vertical MILLING SLIDE

MA-68

This slide is indexed for angle work and has separate tongued base. A Refined Slide with 5" x 4" Table.

Special Type VEE-BLOCKS

Can be bolted to Faceplate or Slide and the job bolted independently to the block.



MA-73

Small size 3" x 1 1/2" x 1 1/2" high.

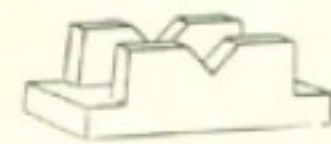

MA-74

4" x 2" x 1 1/4" high.



CHUCKS

MA-76. Best quality 4" Independent Jaw Chuck.

Also MA-75 (not illustrated), a 3" Geared Scroll S/C Chuck, accurate and dependable.

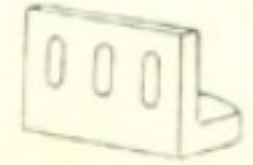

ANGLE PLATE

MA-70. 3" x 2" x 1 1/2". Has 3 slots to match the Faceplate. Can be bolted to vertical slide thereby making a Horizontal Table.

Motorised Stand Units



Simple and efficient are the only words that can express the quality of this Motorised Unit.

It is fully portable and equally suitable for Technical Schools, Private Workshops and Trade alike. Economical to buy and to use. The compact sturdiness with massive Stand and Tray is seen at a glance.

The Unit illustrated comprises Stand with special Countershaft and Motor Brackets, complete with Belts.

For Bench Lathes we have in production a new complete Motor Unit. When fitted with motor this forms a compact, self-contained 3-speed unit. Particulars on application.

MOTORS EXTRA, according to type.

COMPLETELY MOTORISED LATHES (less Motor).

Ready for Cutting when Motor fitted.

LATHE	with	STAND					
ML-1	MA-80	£12	5 0
ML-2	MA-80	£13	10 0
ML-3	MA-81	£15	3 6
ML-4	MA-81	£16	2 6

Prices (less Motor):

STAND UNIT TYPE MA-80, for 3 $\frac{1}{8}$ " Lathe	...	£5	5 0
STAND UNIT TYPE MA-81, for 3 $\frac{1}{2}$ " Lathe	...	£5	13 6



Reliable Motors

B.T.H., HIGGS,
BEST BRITISH
MAKES,

Also Continental Types.
Prices from 37/6
upwards.

ALL PRICES ARE EX WORKS.

