

14" THICKNESS PLANER

OPERATING AND MAINTENANCE INSTRUCTIONS

A planer requires a reasonable amount of care and attention to insure perfect performance and accurate work, and no matter how good the manufacturer makes the machine, the operator must take good care of it, if it is to continue to give the best result. It will take just a few moments to read and familiarize yourself with these instructions and they will probably save you a lot of trouble and time.

INSTALLATION

Your GENERAL 14" Planer is shipped complete, wrapped in waterproof paper and packed in a crate, but less sub-base and motor. Remove the crate and paper, but leave the bottom part of the crate until you are ready to place the planer on its sub-base. This is important otherwise the shaft may be bent as the handwheels extend below the level of the planer base. The protective coating applied on the exterior part of the machine should be wiped off.

Your planer is now ready to place and bolt on its sub-base. Our bases are supplied already drilled to receive the planer, and you need only bolt it in place.

POWER REQUIRED

We recommend the use of a 2 H.P. motor for average work, however if wide pieces at capacity of cut are planed, a 3 H.P. motor will be necessary. Use three-phase current whenever the power is available. The motor bracket of the sub-base have holes in it to receive Cema #184 frame motors. The cutter-head is driven by two matched V-belts and a 3600 R.p.m. motor should be used. This motor with the two groove pulley of the cutter-head will give a speed of 4500 R.p.m. to the cutter-head, and a lineal feed rate of 15 feet per minute. At this feed, 75 cuts per inch are taken a minute, and it will give a smooth finish requiring the minimum of sanding.

MOUNTING THE MOTOR

Remove the belt guard from the planer. Remove the belt guard from the sub-base and its rear panel.



Then place the two groove motor pulley on the motor shaft but do not tighten in place. The motor is then placed on the brackets through the rear panel opening, attach the motor to the brackets with screws and nuts.

V-belts must run true to prevent excess wear and loss of power, and must be matched to exact length. Therefore, the pulleys must be in alignment. To line up the pulleys accurately, take an ordinary plumb placing it in the groove of the cutter-head pulley. Then move the motor pulley to line up and tighten the set screw of the pulley.

If necessary the motor and its mounting brackets can be shifted on the tie rods by loosening the collars; moved to the desired position and the collars tighten again.

The belts must have the correct tension and are just right when they can be depressed 3/4" by pressing with the thumb on one side. To obtain the correct belt tension, adjust the nuts on the eye bolts below the tie bar and lock in place. Now replace the rear panel, and belt guard of the sub-base and of the planer.

Be sure when the wiring is done that the motor rotates in the right direction as the cutter-head must turn toward you when facing the front in the position to plane stock.

ADJUSTMENTS

Your planer leaves the factory completely adjusted and ready to operate, however a check-up is recommended both to familiarize yourself with it and to be sure that everything is in order.

TABLE

The table is raised or lowered by the handwheel at the right side. This handwheel turns the elevating shaft through helical gears which in turn lowers or raises the table. Any wear that develops between the table and the side columns can easily be taken-up by the adjustable gibs. As the table must be raised and lowered easily, yet must not be loose, this adjustment should be checked and readjusted if needed. This is done by loosening the locknuts at the rear of the table, readjusting each screw and locking again.

FEED ROLLS

These rolls are most important in keeping the stock feeding smoothly and must be adjusted with care. To adjust the top rolls proceed as follows: two pieces of hard wood of exactly the same thickness are placed on the table one on each side. Then the table is raised until the knives just touch the wood. The adjusting screws at each end of the rolls are loosened and turned until they just touch the roll blocks, then the two screws for the front roll (corrugated) are loosened 1/2 turn and the two screws for the rear roll (smooth) are loosened 1/4 turn, now all are locked in place with the jam nuts.

The pressure on the top feed rolls can be adjusted easily by tightening or loosening the screws on top of the columns. Do not use more pressure than necessary to feed the stock. Occasionally the surface of the rolls and of the table will become gummed-up, this should be wiped off but never scraped off.

TABLE ROLLS

The table rollers are also most important in keeping stock feeding smoothly. They are adjusted by using a straight edge and a feeler gauge, raising or lowering the rolls to .005 for hard wood and .010 for soft wood. The adjustment is made under the table by the screws provided. The outside table rolls are placed level with the table. Table rolls must not be set too high as they will cause undercutting at both ends of the stock.

CHIPBREAKER AND PRESSURE BAR

To adjust, use the same procedure as for the upper rolls, placing two equal pieces of hard wood on the table and raising it until the knives barely touch. When the adjusting screws on the chip-breaker touch the roll blocks, they are loosened 1/2 turn and locked. The screws for the pressure bar are only loosened 1/4 turn and locked. The pressure on the pressure bar is adjusted the same way and just the right amount should be used to prevent any undercutting at the end of the stock as it leaves the planer.

CUTTER-HEAD

The cutting circle is 3" diameter with three knives. It is very important that the knives be exactly parallel with the table otherwise the stock will be thicker on one side. The knives must all be set equal to a true circle otherwise the cutting load will be shared by only one or two knives and the finish of the stock will suffer accordingly. The knives are held securely in place by combination chip-breaker wedge clamps and square head screws.

The knives should protrude about 1/16 above the chip-breaker and to adjust or replace after sharpening proceed as follows: Two pieces of hard wood dressed on both sides and of equal thickness are placed on the table under the cutter-head one on each side. Now place one knife in the cutter-head and clamp lightly in place after it protrudes the proper distance above the chip-breaker wedge clamp. The table is now raised until the knife barely touch the wood blocks. The other knives are now inserted and clamped just enough to hold them in place. Rotate the cutter-head in a backward motion by hand and the wooden blocks will force all the blades into the same position in the head. Now tighten all the screws a little at a time and repeating until they are all tight.

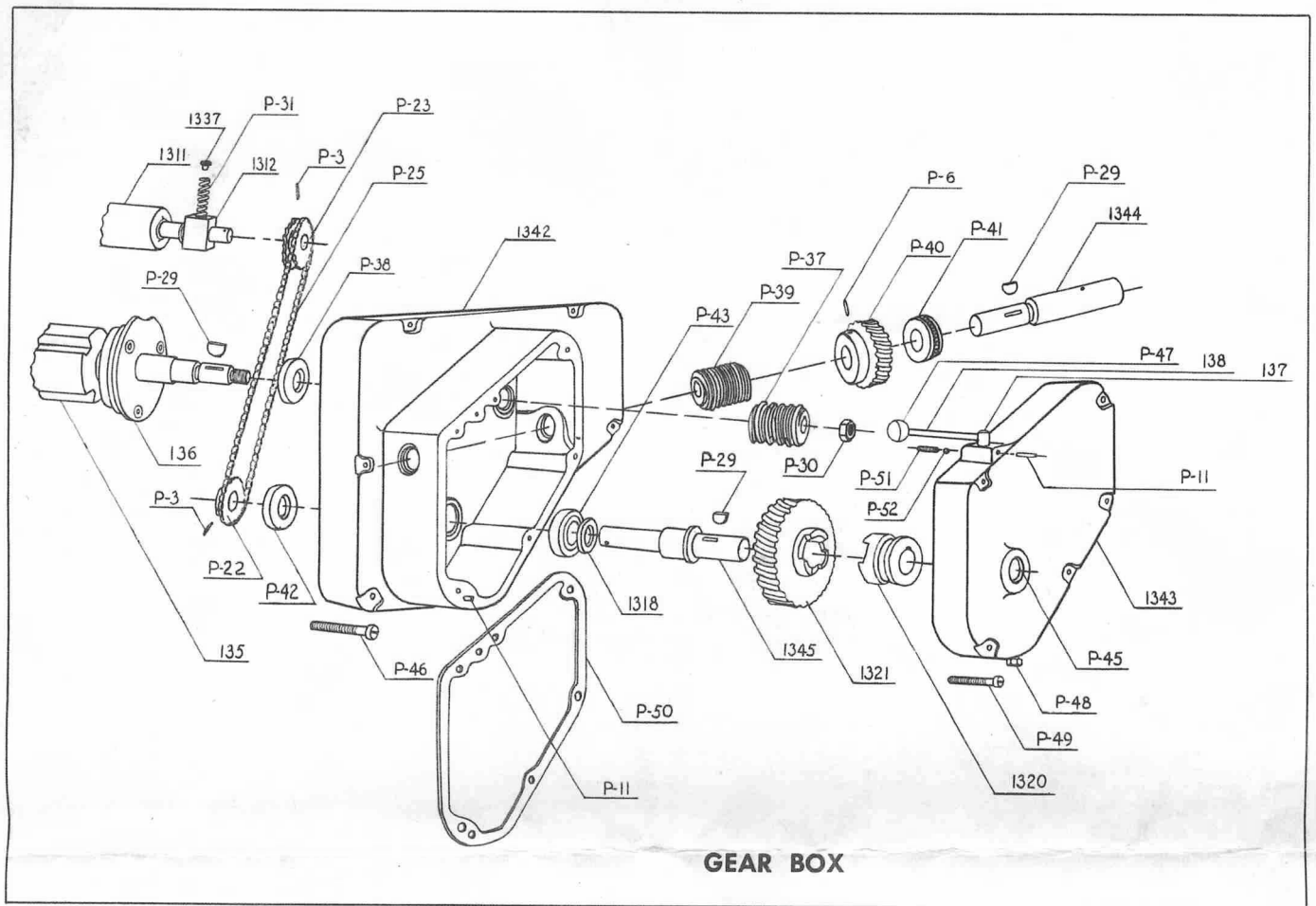

GEAR BOX

By using blocks of an exact dimensions (example 2½" thick) raising the table to indicate 2½ on the thickness scale when you are replacing the knives, the setting of the scale, top rolls, chip-breakers and pressure bar need not be changed once they have been adjusted and we recommend that this method be used.

GEAR BOX MECHANISM

This gear box mechanisms reduces the speed of the cutter-head to drive the feed rolls through sprockets and roller chains. The shifter rod outside the gear box, stops or starts the feed by a three jaw clutch. To replace worn-out roller chains and sprockets, the gear box must be removed. This is done by taking off the cover, the worm on the cutter-head and then the box can be removed. To re-assembly reverse procedure.

LUBRICATION

The cutter-head runs in two sealed ball bearings which are prelubricated for their entire life and require no further attention. The ball bearings of the table rolls and the thrust bearings of the elevating screws

have been packed with grease and will not require further attention. The porous bronze bushings of the upper rolls are saturated with oil and will run a considerable time without attention but should still be oiled periodically by the holes provided in the roll blocks. The same applied to the bushings of the elevating mechanisms.

The helical gears of the elevating screws should be packed with grease before placing on the stand after which little attention is required. The outside table rolls, table and column ways, and elevating screws should be oiled often.

The gear box should be filled with gear lubricant S.A.E. 90 or equivalent by the plug provided at the top of the gear box. Fill to the level of the rear plug, any excess will cause overheating. The amount of lubricant should be checked every month as the mechanisms inside must **never run dry**. The oil should be drained by the plug underneath the gear box and refilled with new lubricant every six months.

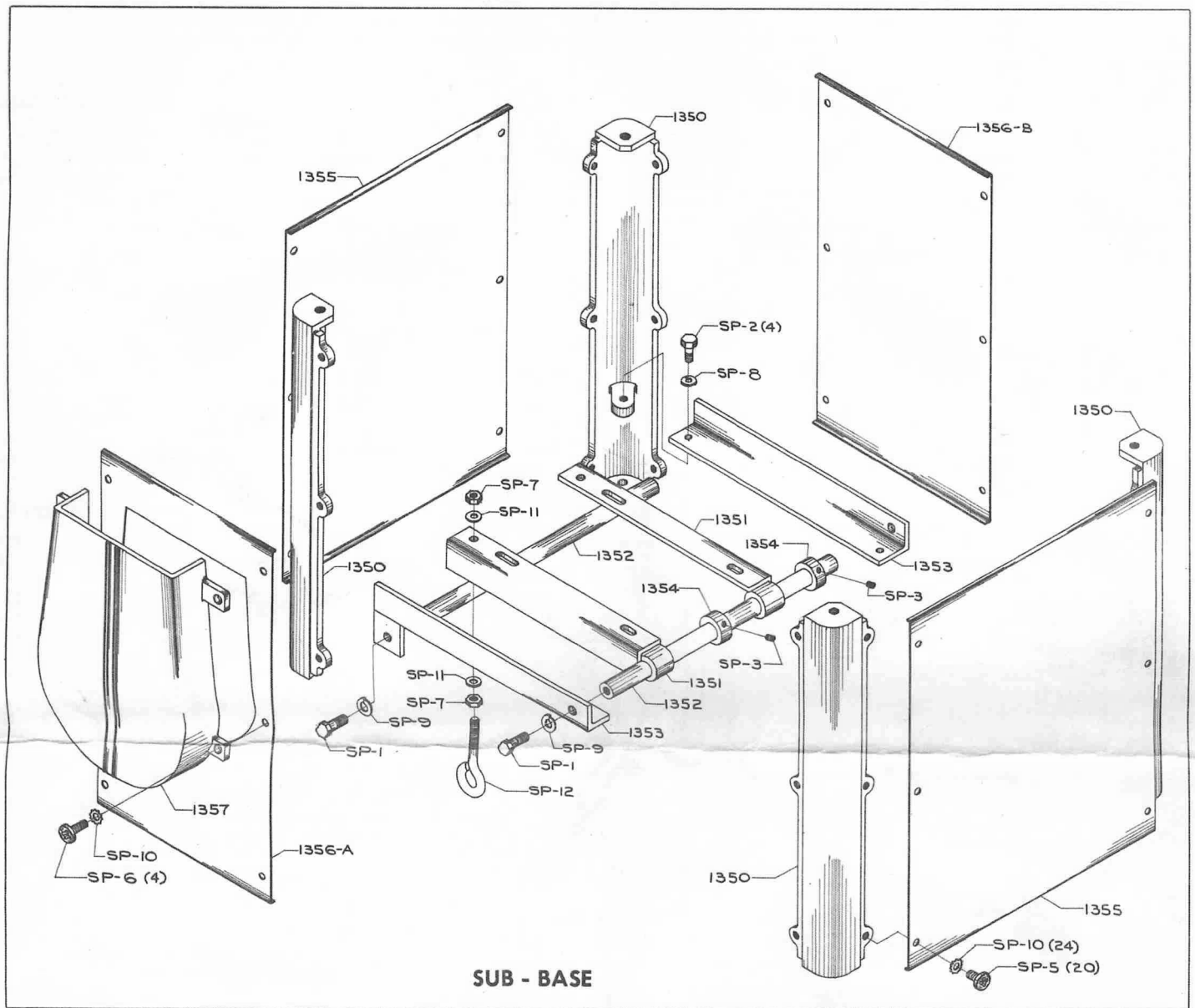

REPLACEMENT PARTS

IMPORTANT: ALWAYS GIVE PART NUMBER AND DESCRIPTION OF EACH ITEM WHEN ORDERING — ALSO GIVE SERIAL NUMBER OF PLANER.

Part No.	Description	Quant.	Part No.	Description	Quant.
Sub-Base					
1350	Leg	4	SP-5	5/16 x 3/4 Philips Pan. H. Mach. screw	20
1351	Motor Support	2	SP-6	5/16 x 1 Philips Pan. H. Mach. screw	4
1352	Motor Support Rod	2	SP-7	3/8 H.H. Jam Nut	4
1353	Rod Anchor	2	SP-8	3/8 Med. Spring Lock Washer	8
1354	Collar	2	SP-9	7/16 Med. Spring Lock Washer	4
1355	Front and Rear Panel	2	SP-10	5/16 Toothed Lock Washer	24
1356	Side Panel	2	SP-11	3/8 Med. Flat Washer	4
1357	Belt Guard	1	SP-12	3/8 x 3/8 Eye x 5" L. Eye Bolt	2
SP-1	7/16 x 1 H.H. Cap screw	4			
SP-2	3/8 x 1 H.H. Cap screw	4			
SP-3	5/16 x 5/16 H. Socket H. Set screw	2			

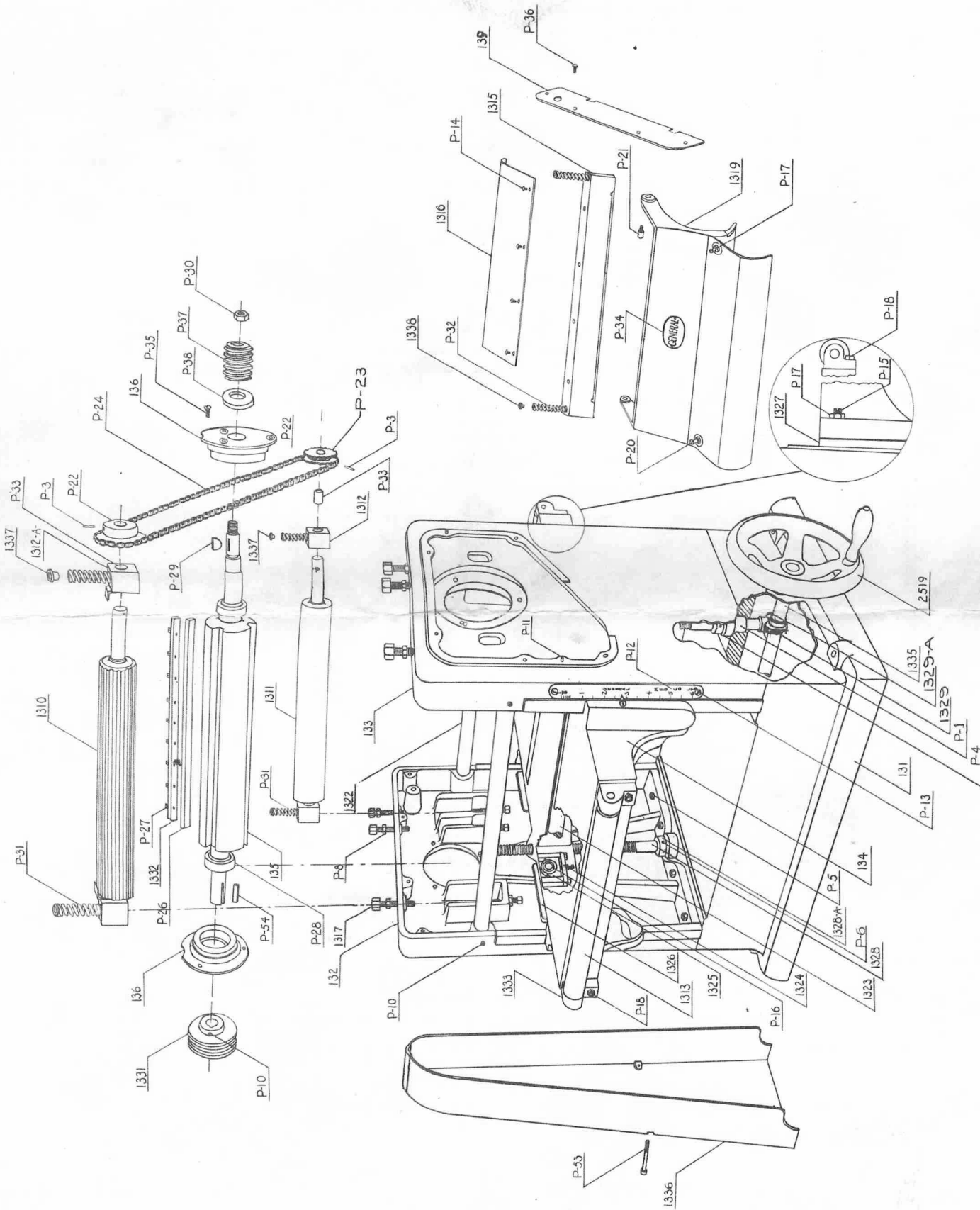

14" PLANER

REPLACEMENT PARTS

IMPORTANT: ALWAYS GIVE PART NUMBER AND DESCRIPTION OF EACH ITEM WHEN ORDERING — ALSO GIVE SERIAL NO. AND SIZE OF PLANER.

Part No.	Description	Quant.	Part No.	Description	Quant.	Part No.	Description	Quant.
Base and Column Assembly			Feed Rolls, Chip-Breaker, Pressure Bar					
131	Base	1	1310	In-feed roll, grooved	1	P-25	Roller Chains 38 P.	1
1335	Elevating Shaft	1	1314	Thrust washer	4	P-22	18 T. Sprocket- $\frac{3}{8}$ bore	1
1329	Helical gear 11 T.	2	1312A	In-feed roll bearing block	2	P-3	3/16 x 1 $\frac{1}{4}$ grov-pin	2
1329-A	Helical gear 16 T.	2	P-31	Compression spring	4	P-42	13520 oil seal	1
P-3	3/16 x 1 $\frac{1}{4}$ grov-pin	4	1337	Spring pad	4	P-43	6203 bearing	1
P-1	A-895 Bearing	4	P-33	A-838-5 Oilite Bearing	4	1318	Spacer	1
P-4	Thrust bearing	2	P-22	18 T. Sprocket- $\frac{3}{4}$ bore	1	1345	Clutch shaft	1
2519	Handwheel	1	P-3	3/16 x 1 $\frac{1}{4}$ grov-pin	3	P-29	606 Woodruff Key	2
1328	Elevating screw	2	P-24	Roller chain 45 P	1	1321	Worm gear with jaws	1
1328A	Screw collar	2	1311	Out feed roll	1	1320	Clutch	1
P-6	3/16 x 1 $\frac{1}{4}$ grov-pin	3	1312	Outfeed roll bearing block	2	P-45	FP-7 expansion plug	3
P-5	$\frac{3}{8}$ x $\frac{7}{8}$ cap screw	8	P-23	18 T. Sprocket double	1	P-39	Soft worm	1
132	Left column	1	1319	Chip-breaker	1	P-40	Bronze worm gear	1
1317	Pressure adj. screw	6	P-17	5/16 Hex Jam nut	2	P-6	3/16 x 1 $\frac{1}{2}$ grov-pin	1
P-8	$\frac{3}{8}$ Hex Jam nut	12	P-20	5/16 x 1 $\frac{1}{2}$ set screw	2	P-41	Thrust bearing	1
P-10	5/16 x 5/16 Allen screw	4	P-34	Name plate	1	1344	Intermediate shaft	1
P-7	$\frac{3}{8}$ x 1 $\frac{3}{4}$ set screw	4	P-21	$\frac{3}{8}$ x $\frac{1}{2}$ socket screw	2	P-47	Shifter rod ball	1
P-9	$\frac{3}{8}$ x 1 $\frac{1}{2}$ set screw	2	1315	Pressure bar	1	138	Shifter rod	1
1336	Belt Guard	1	P-32	Compression spring	2	137	Shifter	1
P-53	1 $\frac{1}{4}$ x 3 $\frac{1}{2}$ Fill H. screw	3	1338	Spring pad	2	P-11	3/16 x $\frac{3}{4}$ grov-pin	3
139	Cover	2	1316	Outfeed roll cover	1	P-51	Compression spring	1
P-36	10/32 x $\frac{3}{8}$ F.H. screw	8	P-14	$\frac{1}{4}$ x $\frac{1}{2}$ R.H. screw	4	P-52	Shifter locking ball	1
1322	Tie rod	2	Cutter-Head Assembly			P-50	Gasket	1
133	Right column	1	135	Cutter head	1	1343	Gearbox cover	1
P-12	6" depth scale	1	1332	Chip-breaker	3	P-48	Oil plug	2
P-13	10/32 x $\frac{1}{4}$ R.H. screw	3	P-27	1 $\frac{1}{4}$ x $\frac{1}{2}$ screw	24	P-49	$\frac{1}{4}$ x 1 $\frac{1}{2}$ F.H. screw	5
P-11	3/16 x $\frac{3}{4}$ grov-pin	2	P-26	$\frac{1}{8}$ x $\frac{3}{4}$ x 14 $\frac{1}{8}$ knife	3			
P-55	Serial plate	1	P-28	WC-88505 Bearing	2			
Table Assembly			P-54	Flat Key	1			
134	Table	1	1331	2 groove pulley	1			
1323	Idler roll	2	P-10	5/16 x 5/16 allen screw	1			
P-16	Roll bearing	4	136	Bearing Housing	2			
1325	Bearing retainer	4	P-35	5/16 x $\frac{3}{4}$ F.H. screw	6			
1324	Clamp	4	P-38	13528 oil seal	1			
P-18	5/16 x $\frac{7}{8}$ cap screw	12	P-29	606 Woodruff Key	1			
P-17	5/16 Hex Jam nut	10	P-37	Hardened worm	1			
P-19	5/16 x 1 $\frac{1}{4}$ set screw	4	P-30	$\frac{3}{4}$ Hex Jam nut	1			
P-15	5/16 x $\frac{7}{8}$ Headless screw	6	Gear Mechanism					
1313	Outside table roll	2	1342	Gear box	1			
1333	Outside roll bracket	4	P-46	5/16 x 1 $\frac{1}{4}$ F.H. screw	5			
1326	Guide bar	4						
P-44	$\frac{1}{4}$ x $\frac{3}{8}$ R.H. screw	8						
1327	Gib	2						

GENERAL MFG. CO. LTD.

MANUFACTURER OF CIRCULAR SAWS, BAND SAWS, WOOD LATHES, PLANERS, JOINTERS, MORTISERS, DRILL PRESSES, SHAPERS, AND SANDERS.