



DEWALT®

radial arm saws

for industry and the construction trades



- Tightened location accuracy with zero play latches in bevel, rip and miter positions.

- Improved rigidity in bevel, rip and miter position clamping.

- Dust-proofed latches for greater unit reliability.

- Made the column corrosion-resistant.

- Eliminated universal joint for more efficient and reliable elevation system.

- Made the front elevation crank removable to eliminate bumping hazard.

- Improved clamping with wide-contact table clamps.

- Speeded the take-up on table clamps for faster changeover to different size rip fences.

- Improved rip scale readability.

- Strengthened arm and end cap and dust-proofed the heavy-duty "On-Off" switch.

- Engineered a positive locating bevel stop rod.

- Installed heavy duty stop bumpers to prevent roller head from over-traveling.

- Put fool-proof roller head safety stops at front and rear of arm.

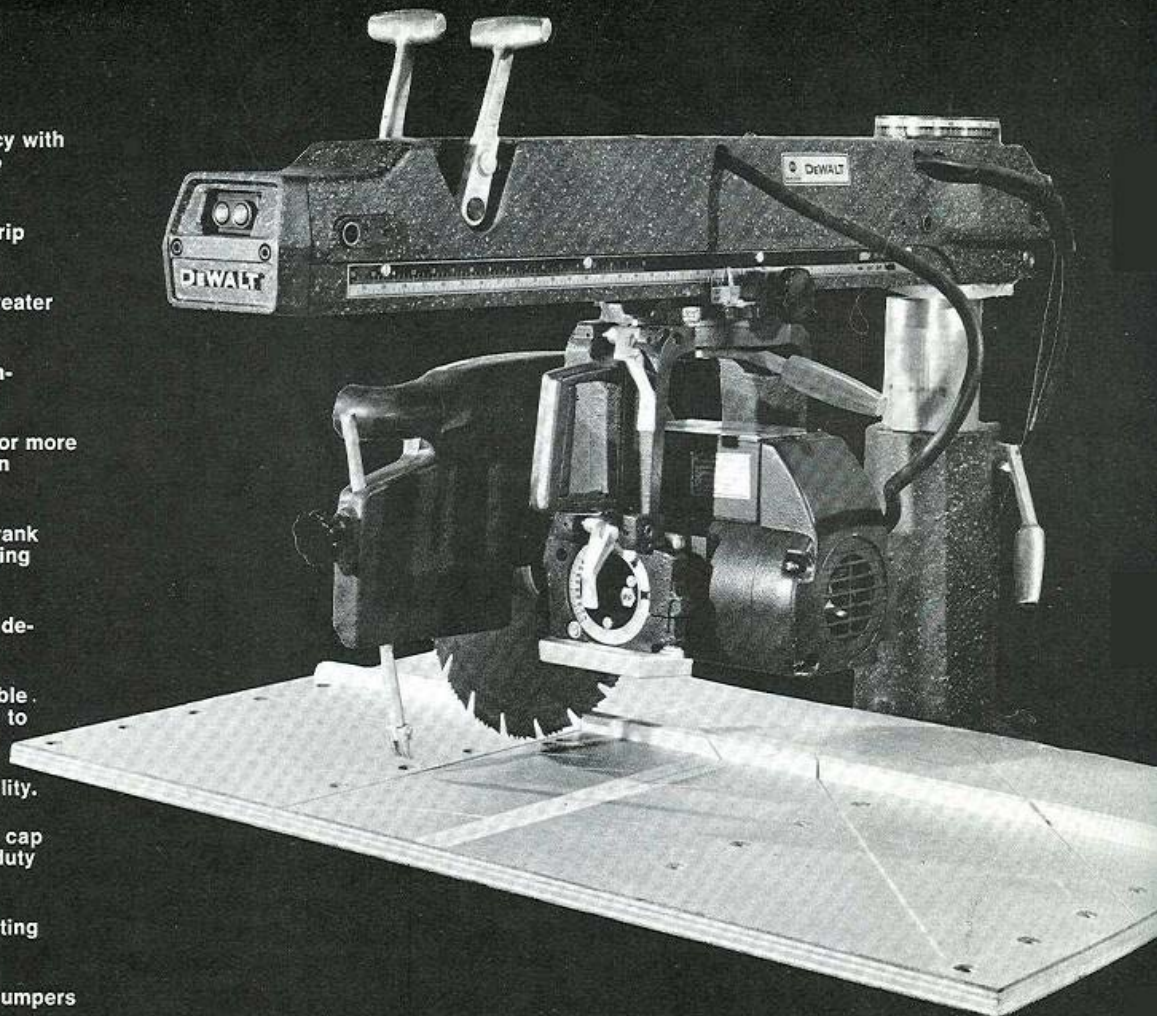

DeWalt Heavies-A complete line- engineered up again!

DeWalt stays first in heavy-duty radial arm saws through constant improvements and a full line.

In this brochure, you'll find a range of DeWalt Heavies from 18" to 10". There's an outstanding value for every job you have to do.

And you'll also find important new engineering improvements. They make DeWalt

more than ever your best buy for steady, superior performance and long life.

Look over the new DeWalt Heavies. Then try them out at your DeWalt distributor's.

You'll like what the engineers did to the DeWalt 16" and 18" Heavies!

DeWalt . . . the complete line

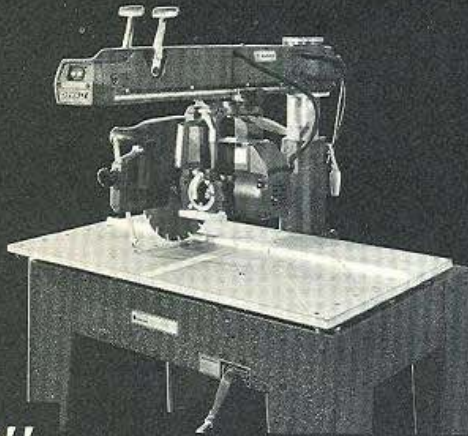

18" 6 Models 2 Arm Lengths
3 Motor Choices See page 3

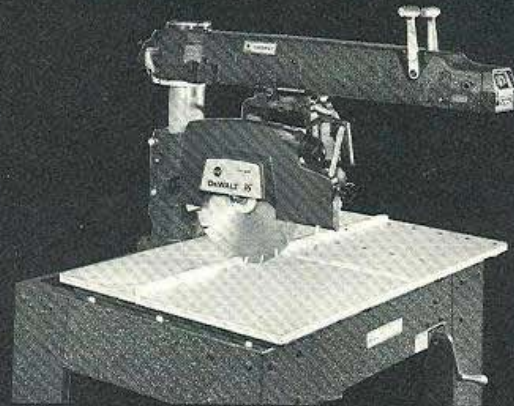

16" 6 Models 2 Arm Lengths
3 Motor Choices See page 5

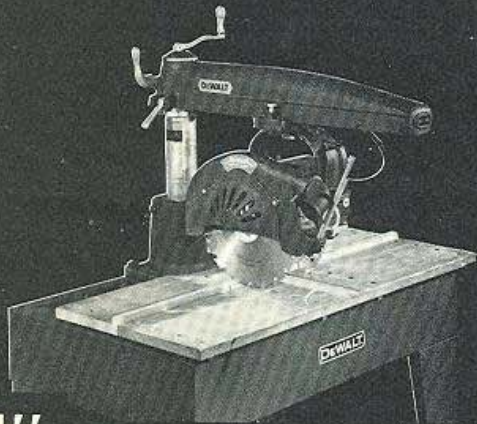

14" 6 Models 2 Arm Lengths
3 Motor Choices See page 6

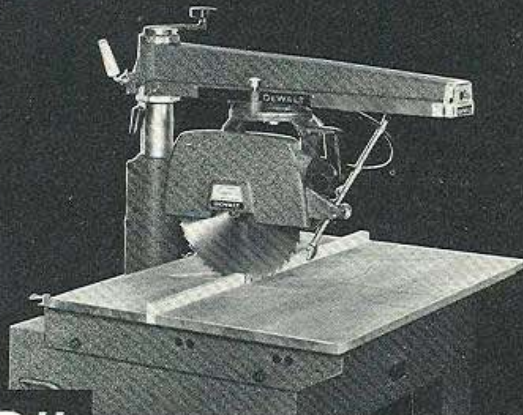

12" 2 Models See page 7

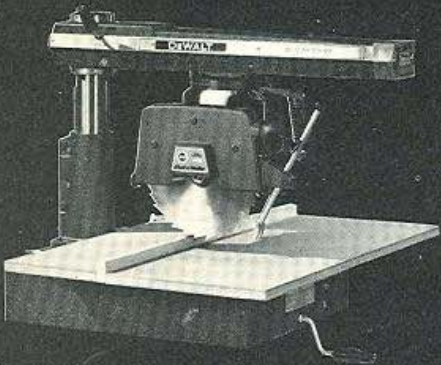

10" Brings DeWalt accuracy and dependability right to the job site. Ruggedness and extra power for contractors and builders. See page 8.

INTRODUCING OUR NEW NUMBERING SYSTEM . . .

With this new catalog, Black & Decker introduces entirely new numbering system for the complete DeWalt line. The cross-reference chart and a complete explanation of this new numbering system can be found on the inside of the back cover of this catalog.

DeWalt . . . the complete line. On the following pages, you will find just the right Radial Arm Saw to suit your specific needs. A wide range of sizes, motors, capacities, arm lengths and accessories . . . all designed to give you rugged and dependable performance.

DeWalt 18" radial arm saw

Models 3552, 3557, 3562, 3567, 3572, 3577

One new and improved DeWalt 18" does all the work of a swing saw, straight line cut-off and miter saw, table type rip saw, dado machine, shaper and many others! Solidly based on heavy-gauge steel table and legs. The table top is 1" thick, warp-resistant "HARDPLY" with quick-takeup clamps. Corrosion-resistant column. Rugged cantilever arm with heavy duty "On-Off" switch. Head rolls inside on 8 ball bearings, with safety stops at front and rear. Long life Black & Decker/DeWalt-built motor with even greater burnout protection. Electrical controls. Automatic built-in brake. 18" saw guard. 18" combination saw blade, arbor nut and collars and arbor wrenches.

Arm rotates 360°, locks rigidly at any angle for mitering. Bevel controls have new zero play latches and improved clamping; fast, precise setting at 0°, 45° and 90°. Mechanical alignment adjustments for lifetime accuracy.

Yoke swivels 360°, automatically locates in-rip, out-rip and crosscut positions. Medium and long arms give capacity choice for industry, lumber yards, sash and door plants, production lines, general contractors, mining operations, government shops.

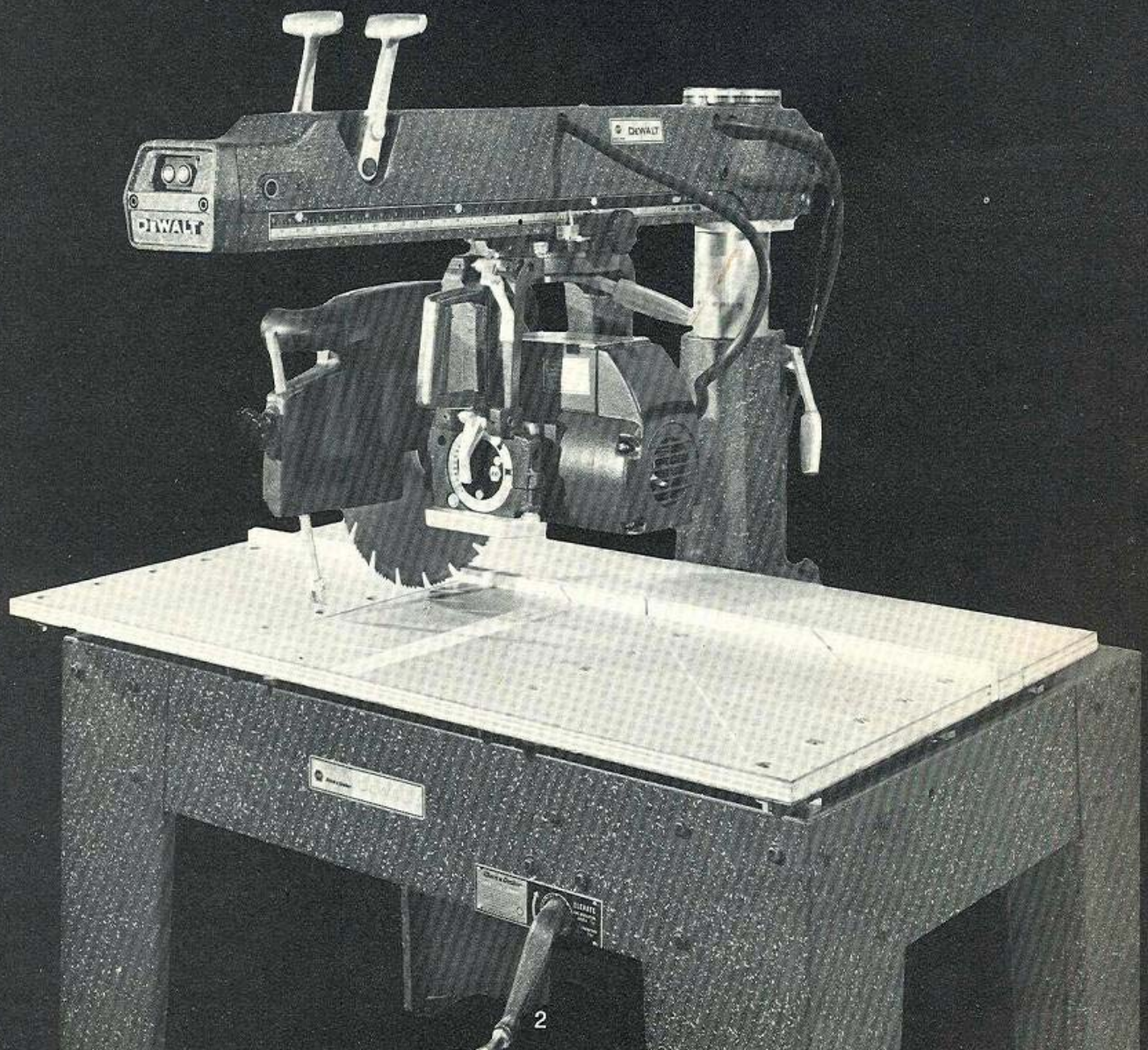

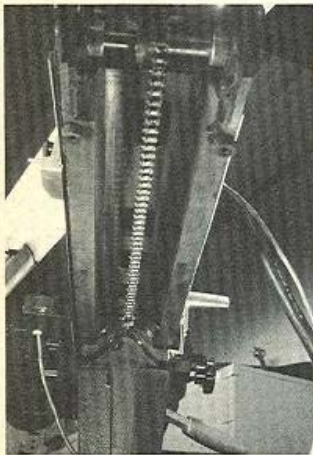

Manual Chain Cross Feed control for all heavy-duty cross cutting. Added operator safety.



Optional accessories convert saw to a dado machine.



Simple, high-speed production rip feed with variable speed control.

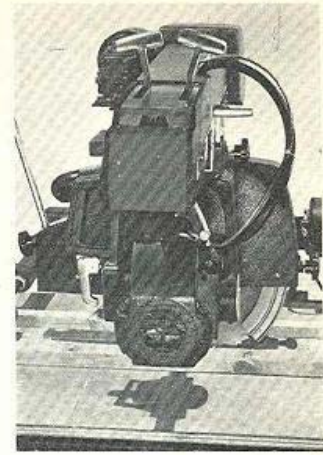

Automatic power safety rip feed with variable speed control.

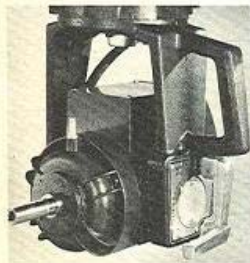

Black & Decker/DeWalt custom built motor. Totally enclosed. Sealed-for-life ball bearings. No lubrication.

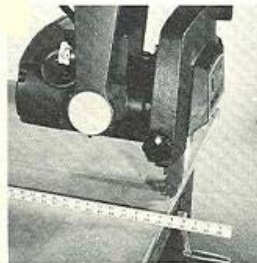

Big work table gives you 50" x 30 1/8" of work area. Ruggedly built of 1" warp-resistant HARDPLY®.



Blade guard has anti-kickback device. Built-in metal dust chute.



Automatic motor brake stops the cutting tool in seconds. Safest saw stop on any machine!

Specifications

Model	Blade Size	Cont. H.P.	Voltage*	Phase	Cycle	Brake	Arm
3552	18"	5	230	1	60	Yes	Medium
3557	18"	5	230	1	60	Yes	Long
3562	18"	5	230/460	3	50/60	Yes	Medium
3567	18"	5	230/460	3	50/60	Yes	Long
3572	18"	7 1/2	230/460	3	50/60	Yes	Medium
3577	18"	7 1/2	230/460	3	50/60	Yes	Long

NOTE: All motors are equipped with automatic electro-mechanical brakes.
* Motors will operate at plus or minus 10% of rated voltage.

Specify arm size and voltage when ordering. ALL 3 phase motors are connected for 230 V operation. For 460 V operation, motor and transformer must be reconnected and appropriate thermals must be substituted. Contact your local B&D Service Center for proper thermals and instructions.

Motor Rating	Continuous Duty
Motor Enclosure	Totally Enclosed Fan Cooled
Motor Speed (full load)	3425 RPM
Arbor	1" diameter x 3 1/8" long
Brake	Automatic
Switch	110 volt magnetic
Roller Head	Eight (8) ball bearings
Saw Blade	T-2003, 18" Combination

Capacities:

Maximum Out Rip	Medium Arm — 40 3/4", Long Arm — 48 3/4"
Maximum Cross Cut	1" thick stock — Medium Arm — 24", Long Arm — 32"
Maximum Miter 45° R	1" thick stock — Medium Arm — 16", Long Arm — 21 1/8"
Dado Capacity (with standard guard)	12" diameter x 1 1/8" wide
Maximum Depth of Cut (with 18" blade)	5 1/8"
Bevel Locating Latches	0°, 45°, 90°
Miter Locating Latches	0°, 45° R, 45° L

Machine Overall Dimensions:

Height	73 3/4"
Width	50"
Depth	39 1/2"
Steel Table Frame Size	36" x 48" x 8"
Table Top Size	30 1/8" x 50" x 1"
Work Table Height	32"
Column Diameter	4.7"
Net Weight	Medium Arm — 696 pounds, Long Arm — 727 pounds

NOTE: 22" guards are available to accommodate 20" and 22" blades.

For accessories, see page 9 and 10

DeWalt 16" radial arm saw

Models 3551, 3556, 3561, 3566, 3571, 3576

Engineered up with 22 performance and durability improvements! A DeWalt 16" does the work of a whole shopful of special-purpose saws and shapers. A big producer for residence builders, cabinet shops, lumber yards, vocational schools, industrial plants and woodworking shops. Fast, smooth, precise. Roller head rides inside arm on 8 lubricated-for-life ball bearings. Arm rotates 360°, locks securely at any angle for accurate mitering. New bevel controls have zero play latches and improved clamping; they provide fast setting at 0°, 45° and 90°. Mechanical alignment adjustments assure long, accurate life.

Yoke swivels 360°, automatically locates in-rip, out-rip and crosscut positions. Totally enclosed motor is custom built by Black & Decker/DeWalt with direct drive, fan cooling, increased burnout resistance. Automatic electro-mechanical brake. Saw includes heavy gauge steel table and legs; 1" thick warp-resistant HARDPLY® table top; corrosion-resistant column with clamp for rigidity; continuous duty motor; electrical controls; 16" saw guard; 16" combination saw blade, arbor nut and collars and arbor wrenches.

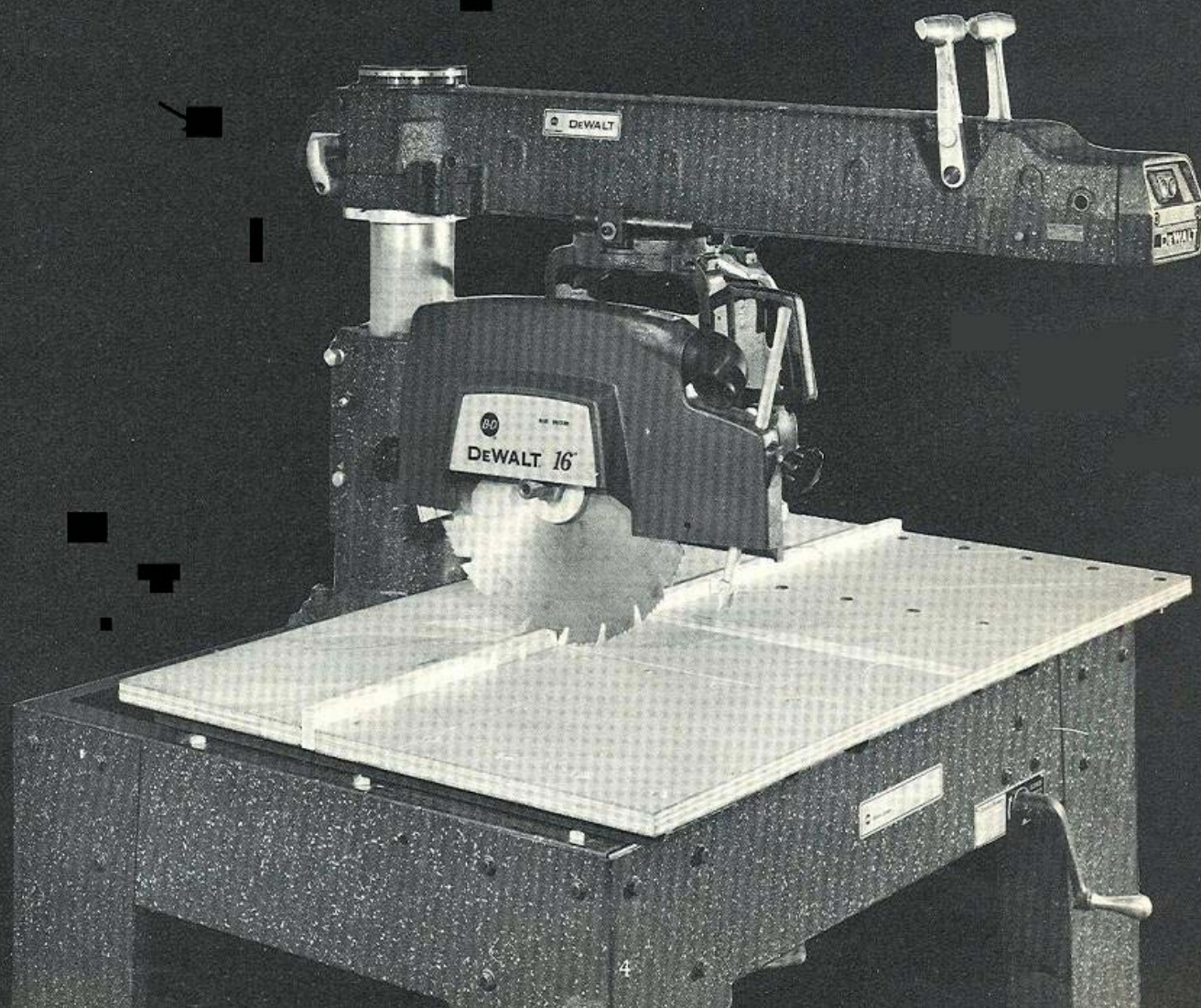

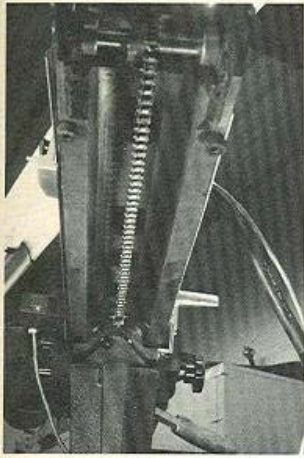

Manual Chain Cross Feed control for all heavy-duty cross cutting. Added operator safety.



Optional accessories convert saw to a dado machine.



Simple, high-speed production rafter notching.



Automatic power safety rip feed with variable speed control.



Black & Decker/DeWalt custom built motor. Totally enclosed. Sealed-for-life ball bearings. No lubrication.

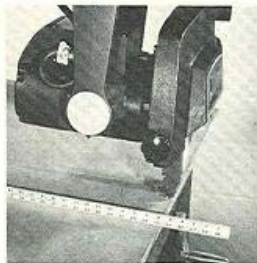

Big work table gives you 50" x 30 1/4" of work area. Ruggedly built of 1" warp-resistant HARDPLY®.



Blade guard has anti-kickback device. Built-in metal dust chute.



Automatic motor brake stops the cutting tool in seconds. Safest saw stop on any machine!

Specifications

Model	Blade Size	Cont. H.P.	Voltage*	Phase	Cycle	Brake	Arm
3551	16"	5	230	1	60	Yes	Medium
3556	16"	5	230	1	60	Yes	Long
3561	16"	5	230/460	3	50/60	Yes	Medium
3566	16"	5	230/460	3	50/60	Yes	Long
3571	16"	7 1/2	230/460	3	50/60	Yes	Medium
3576	16"	7 1/2	230/460	3	50/60	Yes	Long

NOTE: All motors are equipped with automatic electro-mechanical brakes.
* Motors will operate at plus or minus 10% of rated voltage.

Specify arm size and voltage when ordering. ALL 3 phase motors are connected for 230 V operation. For 460 V operation, motor and transformer must be reconnected and appropriate thermals must be substituted. Contact your local B & D Service Center for proper thermals and instructions.

Motor Rating	Continuous Duty
Motor Enclosure	Totally Enclosed Fan Cooled
Motor Speed (full load)	3425 RPM
Arbor	1" diameter x 3 1/8" long
Brake	Automatic
Switch	110 volt magnetic
Roller Head	Eight (8) ball bearings
Saw Blade	T-2002, 16" Combination

Capacities:

Maximum Out Rip	Medium Arm — 40 3/4"
	Long Arm — 48 3/4"
Maximum Cross Cut — 1" thick stock	Medium Arm 24"
	Long Arm — 32"
Maximum Miter, 45° R — 1" thick stock	Medium Arm — 16"
	Long Arm — 21 5/8"

Dado Capacity (with standard guard)

	12" diameter x 1 5/8" wide
Maximum Depth of Cut (with 16" blade)	4 1/8"
Bevel Locating Latches	0°, 45°, 90°
Miter Locating Latches	0°, 45° R, 45° L

Machine Overall Dimensions:

Height	73 3/4"
Width	50"
Depth	39 1/2"
Steel Table Frame Size	36" x 48" x 8"
Table Top Size	30 1/4" x 50" x 1"
Work Table Height	32"
Column Diameter	4.7"
Net Weight	Medium Arm — 696 pounds
	Long Arm — 727 pounds

For accessories, see page 9 and 10

DeWalt 14" radial arm saw

Models 3500, 3505, 3510, 3515, 3520, 3525

Choose Medium or Standard arm length, 5 or 3 HP motor. The DeWalt 14" is an outstanding Heavy Duty value. You get production and durability that are way beyond any other machine in the market. Genuine Black & Decker/DeWalt custom built motor, totally enclosed and fan cooled. The 14" blade cuts 4 $\frac{1}{8}$ " deep. Wide contact 8-ball bearing saw carriage assures smooth, accurate operation. Proved by residence builders, cabinet shops, small lumber yards, vocational schools, industrial plants and woodworking shops.

The DeWalt 14" includes steel table with legs and wood top, column, uniform cantilever arm, ball bearing roller carriage, motor, electrical controls, 14" saw guard, 14" saw blade, arbor nut and collars and arbor wrenches.

Specifications

Please specify Arm Size and Voltage When Ordering. All 3-phase motors are connected for 208-220V operation. For 440V operation, motor and transformer must be reconnected and appropriate thermals must be substituted. Contact your local B & D Service Center for proper thermals and instructions.

Model	Former Model	Arm Size	H.P.	Voltage	Phase	Cycle
3500	GAN-S	STANDARD	3	208-220/440	3	60
3505	GAN-M	MEDIUM	3	208-220/440	3	60
3510	GAO-S	STANDARD	3	230	1	60
3515	GAO-M	MEDIUM	3	230	1	60
3520	GAR-S	STANDARD	5	208-220/440	3	60
3525	GAR-M	MEDIUM	5	208-220/440	3	60

Motor Rating	Continuous Duty, 3 and 5 HP
Motor Enclosure	Totally Enclosed Fan Cooled
Motor Speed (full load)	60 cycles AC 3425 RPM
Arbor	1" diameter x 2 $\frac{1}{8}$ " long
Switch	110 volt magnetic
Saw Blade — 1" Arbor Hole	T-2001, 14" Combination
Standard Saw Guard	14"
Roller Head	8 Ball Bearings
Machine Overall Dimensions:	
Height	70 $\frac{3}{4}$ "
Width	Standard Arm — 46", Medium Arm — 30"
Depth	20"
Maximum Depth of Cut — 14" Blade	4 $\frac{1}{8}$ "
Maximum Cross Cut — 1" stock	Standard Arm — 16" Medium Arm — 24"
Maximum Miter Cut-Off — 1" stock	Standard Arm — 10 $\frac{7}{8}$ " Medium Arm — 15 $\frac{1}{2}$ "
Maximum out-rip	Standard Arm — 28 $\frac{3}{4}$ " Medium Arm — 36 $\frac{3}{4}$ "
Dado Capacity — Standard guard	10" x 1 $\frac{3}{8}$ " wide
Bevel Locating Latches	0°, 45°, and 90°
Miter Locating Latches	0°, and 45°, R or L
Steel Table Frame Size	Standard Arm — 28" x 44" Medium Arm — 36" x 48"
Wood Table Size	Standard Arm — 20 $\frac{1}{2}$ " x 50" Medium Arm — 26 $\frac{1}{2}$ " x 50"
Height — Work Table	32"
Column Diameter	3.7"
Shipping Weight	Standard Arm — approx. 475 lbs. Medium Arm — approx. 600 lbs.

For accessories, see pg. 11

Model 3510 DeWalt 14" Saw.

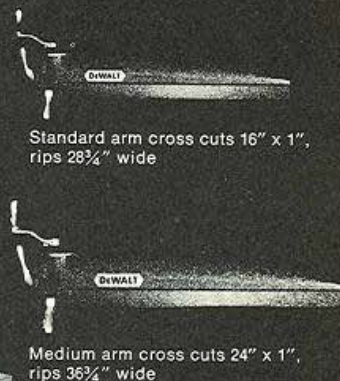
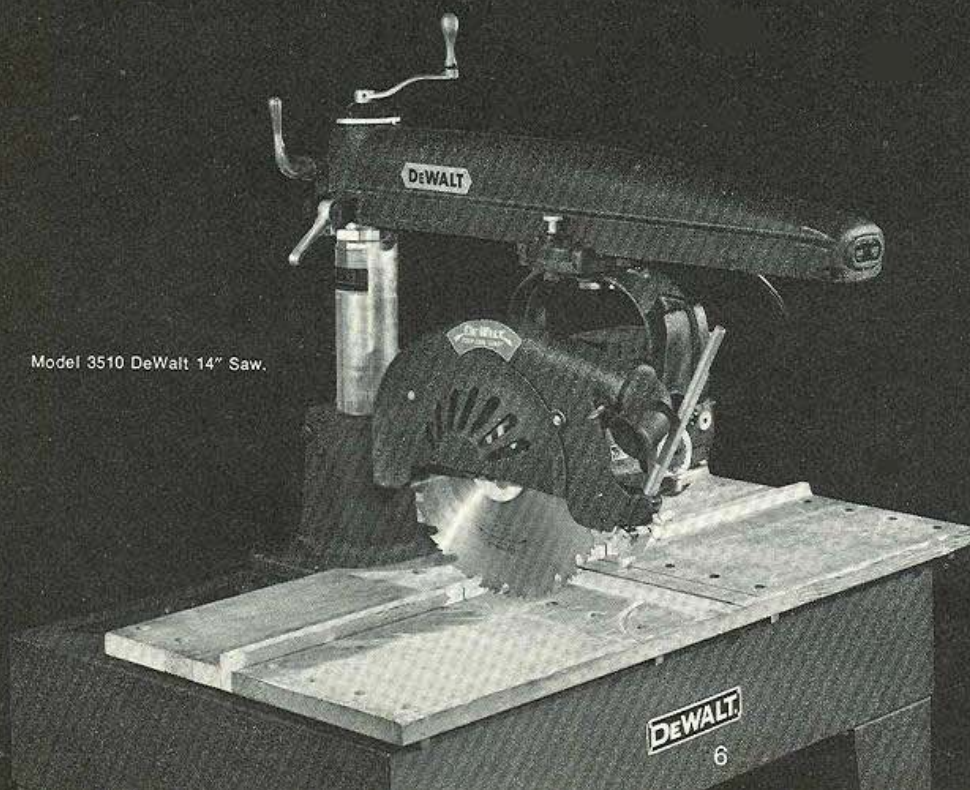

DeWalt 12" radial arm saw

Models 3430, 3435

The DeWalt 12" brings big saw speed and production capacity to contractors, builders and industrial maintenance departments. Cuts a full 4" deep. It stands strong on heavy gauge steel base and legs. Work table is rugged HARDPLY®. Column is electro-plated to prevent rust.

Uniformly rigid cantilever arm rotates 360° horizontally and locks at any angle for mitering. Bevel latches provide quick, precise settings at 0°, 45° and 90°. Lifetime accuracy assured by mechanical alignment adjustments. Roller head rides inside the arm on four shielded, lubricated-for-life ball bearings. Yoke swivels 360° horizontally. Locates at each 90° position for in-ripping, out-ripping and cross-cutting.

Black & Decker/DeWalt custom built motor is totally enclosed, fan cooled, direct drive. Automatic built-in motor brake. Motor has 5/8" diameter left arbor and 3/4" right arbor. Combination safety-key lock switch and push button on-off switch is built into end of arm. 12" guard, 12" combination blade, arbor nut and collars, arbor wrenches, heavy steel base and legs are standard equipment.

Specifications

Model	Former Model	Cont. H.P.	Developed H.P.	Voltage	Phase	Cycle
3430	T-1531	1½	4	120/208-240	1	60
3435*	T-1533	2	5	208-240/440	3	60

* Model 3435 same as 3430 except 3 phase 208-240/440 volt motor, 60 cycle with magnetic switch and low voltage (end of arm) 110 v. control.

Motor Rating	Continuous Duty H.P. 1½ and 2
Motor Enclosure	Totally Enclosed — Fan Cooled
Motor Speed (full load) 60 cycles AC	3450 RPM
Arbor	5/8" Diameter
Brake	Automatic
Switch	Push Button/Key*
Saw Blade — 5/8" Arbor Hole	T-2115, 12" Combination
Saw Guard	12"
Roller Head	4 Ball Bearings
Machine Overall Dimensions:	
Height	62"
Width	34½"
Depth	30½"
Maximum Cut-off	16"
Maximum Depth of Cut	4"
Maximum Miter Cut-off, 45° R	11½"
Maximum Out-rip	27"
Dado Capacity	1 1/4"
Bevel Locating Latches	0°, 45° and 90°
Miter Locating Latches	45° R, 0°, and 45° L
Steel Table Frame Size	26" x 32" x 6"
Hardply® Table Size	25" x 34½" x 3/4" Thick
Height — Work Table	33"
Column Diameter	2¾"
Net Weight	208 lbs.
Shipping Weight	244 lbs.

For accessories, see pg. 12

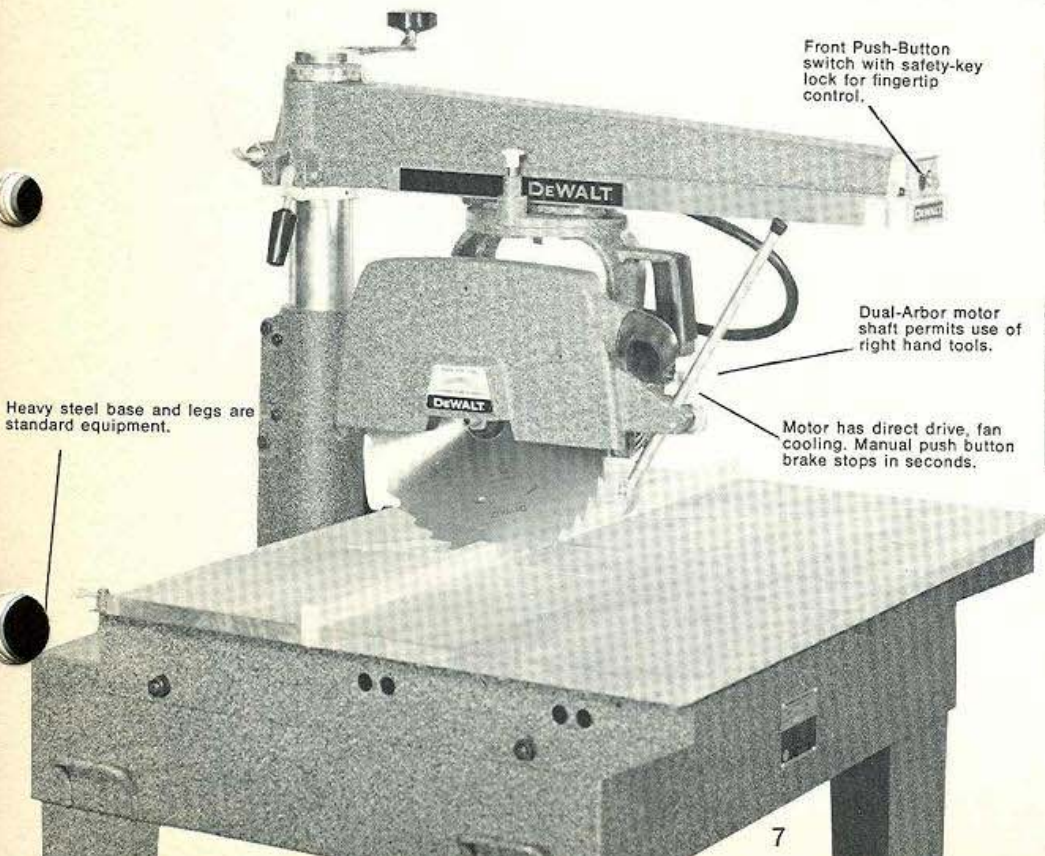

Heavy steel base and legs are standard equipment.

Front Push-Button switch with safety-key lock for fingertip control.

Dual-Arbor motor shaft permits use of right hand tools.

Motor has direct drive, fan cooling. Manual push button brake stops in seconds.



12" blade cuts 4" deep.

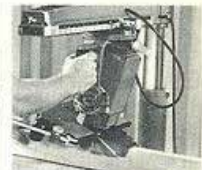

Rafter notching on the job.



Angle cuts up to 16" long.

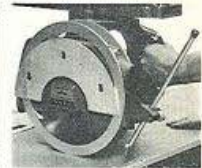

Safety proved in schools and shops.

DeWalt Builders' 10" radial arm saw

Model 3420 (Former Model T-1812)

Big power and versatility in a Builders' 10"! Cuts a full 3" deep. Heavy gauge steel base. The roller head rides inside arm on two precision machine tracks with four shielded, lubricated-for-life ball bearings. The motor is a genuine, custom built Black & Decker/DeWalt with direct drive and fan cooling. Motor has $\frac{5}{8}$ " diameter left arbor. Right arbor is internally threaded for right hand tools. Uniform rigid cantilever arm rotates 360° horizontally and locks at any miter angle. Front single bevel control gives easy, precise settings at 0°, 45° and 90° positions. Front single rip control allows fast positioning of saw head. Steel locator pin automatically finds in-rip, out-rip and cross-cut positions. Push-button panel and safety-key lock switch are located on end of arm for safety. 10" guard, 10" combination blade, arbor nut and colars and arbor wrenches are included.

Specifications

Motor: 1 H.P. Continuous Duty. Develops 2 H.P., 120 V Single Phase	
Full Load Speed 60 Cycle	3450 RPM
Standard Blade	T-2114, 10" Combination
Standard Guard	10"
Front Arbor (Left Hand Thread)	$\frac{5}{8}$ " diameter x 1 $\frac{1}{2}$ " long
Rear Arbor (Right Hand Thread)	$\frac{5}{16}$ " tapped f/R.H. accessories
Roller Head	4 Ball Bearings
Machine Overall Dimensions:	
Height	27 $\frac{1}{16}$ "
Width	32"
Depth	26 $\frac{3}{8}$ "
Maximum Depth of Cut	3"
Maximum Cross Cut	12 $\frac{7}{8}$ "
Maximum Rip Capacity	25"
Dado Capacity	1 $\frac{1}{16}$ "
Maximum Miter Capacity, 45° R	9"
Bevel Locating Latch	0°, 45°, 90°
Miter Locating Latch	0°, 45° R, 45° L
Scales	Miter, Rip, Bevel
Column Diameter	2.75"
Steel Table Size	18" x 21 $\frac{1}{2}$ "
Hardply® Table Size	$\frac{3}{4}$ " x 21 $\frac{1}{16}$ " x 32"
Height Work Table on T-1806 Leg Stand	35"
Net Weight	125 lbs.
Shipping Weight	133 lbs.

For accessories, see pg. 12

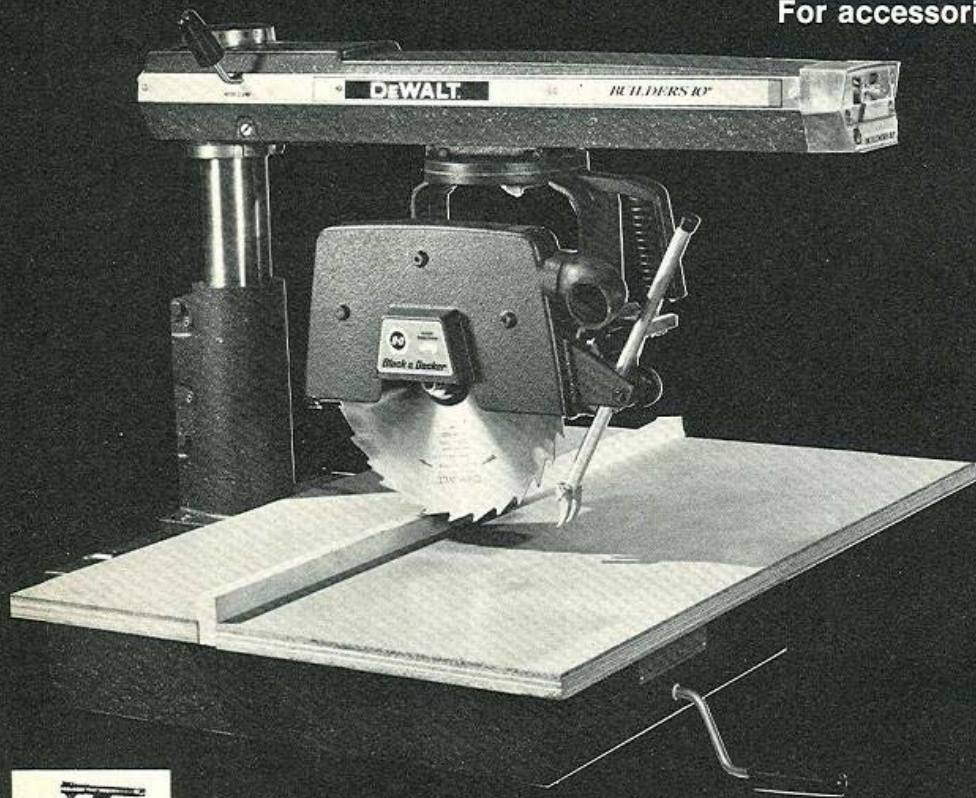

T-1806 leg stand optional at extra cost.

T-40181 Magic Miter Table Top optional at extra cost



Fingertip control with Front Push-Button switch. Safety-key lock.



Exclusive Wedge-Loc Miter Locator locks positively at 0°, 45°. Scale marked in single degrees.



Front single rip control automatically finds in-rip and out-rip positions.



Front single bevel control for quick, precise settings at 0°, 45°, 90°.



Direct drive fan cooled motor. Manual pushbutton brake stops cutter in seconds.



Dual-Arbor motor shaft permits use of right-hand tools.



Up Front elevation control. Precision depth adjustment as fine as $\frac{1}{16}$ ".

Accessories for 16" & 18" radial arm saws



SAFETY ATTACHMENTS

T-1748 Universal Tool Guard — adjustable front and rear sections. Used with shaper head, rafter notching head and other tools.



T-1753 Splitter and Anti-Kickback Device for 16", 18" and 22" Guards.



T-1759 Table Top Extension — extends table to eliminate blade overhang. Fits former models T-1831 thru T-1874.



DADO GUARDS

T-1749 Dado Guard — 12" x 2 1/2" wide.

T-1750 Dado Guard — 12" x 4" wide.

CONVERSION KITS — for converting saw guards to automatic safety guards — free floating device rides over stock being cut.

T-1751 16" Safety Guard Conversion Kit.

T-1752 18" Safety Guard Conversion Kit.



SAFETY GUARD

T-1754 22" Guard w/Anti-Kickback Device for 20" and 22" Saw Blades.

AUTOMATIC SAFETY RETURN DEVICE

40020 Automatic Safety Return Device — returns saw and motor to rear of guide fence, eliminates creeping.

T-1746 Automatic Safety Return Device — returns saw and motor to rear of guide fence, eliminates creeping. For former Models T-1831 thru T-1874.

POWER RIP FEED

Adaptable to all 16" and 18" machines. Has variable speed control motor with speeds from 0 to 90 feet per minute, adjustable depth regulator, steel sprocket in-feed wheel and rubber take-off wheel.

T-1736 Safety Power Rip Feed with 115 volt, 1/4 HP, 1725 RPM motor.

MANUAL CHAIN FEED

provides full control for heavy production work. For heavy sawing, dadoing, and rafter-notching.

40021 Chain Feed for Medium Arm Machines.

40022 Chain Feed for Long Arm Machines.

T-1732 Chain Feed for Former 16" machines, type AAA and Models T-1851, T-1873, and T-1670.

T-1713 Chain Feed for former Models T-1852 and T-1874.

T-1731 Chain Feed for Former 16" machines, Type A & AA.

40019 Track Wipers — keeps roller head track clear of dirt and dust.
T-1660 Track Wipers — keeps roller head track clear of dirt and dust. Former models 16" Type AAA, 18".



ROLLER EXTENSION TABLE AND ACCESSORIES

40030 Roller Extension Table, 17" wide x 8 feet long. Includes eight rollers. Uses T-1735 Support Legs.

T-1734 Roller Extension Table, 17" wide x 8 feet long. Includes eight rollers. Uses T-1735 Support legs. Former Models only — 16" and 18".

T-1735 Adjustable Support Legs for roller extension table.

T-1743 Cut-off Gauge, 10 feet, left to right. With one automatic adjustable stop.

T-1744 Cut-off Gauge, 10 feet, right to left. With one automatic adjustable stop.

T-1745 Automatic Adjustable Stop.



SPACING COLLARS

T-2413 Spacing Collar 1/16" thick x 1" arbor hole.

T-2414 Spacing Collar 1/8" thick x 1" arbor hole.

T-2415 Spacing Collar 1/4" thick x 1" arbor hole.

T-2420 Spacing Collar 1/2" thick x 1" arbor hole.

T-2426 Spacing Collar 1" thick x 1" arbor hole.



SUPPORT COLLARS

T-2214 6" Steel Support Collars — set of two.

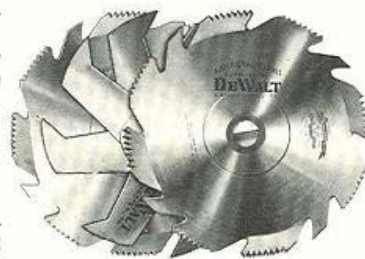

(Flat Ground)

NO. 3 DADO SETS — consisting of two each 1/8" outside blades, two 1/8" inside chippers, one 1/4" inside chipper, and one 1/16" inside chipper.
T-2853 Dado Set, 8" dia. x 13/16" wide x 1" arbor hole.
T-2854 Dado Set, 10" dia. x 13/16" wide x 1" arbor hole.

(Hollow Ground)

NO. 3 DADO SETS — consisting of two each 1/8" outside blades, two 1/8" inside chippers, one 1/4" inside chipper, and one 1/16" inside chipper.
T-2850 Dado Set, 8" dia. x 13/16" wide x 1" arbor hole.
T-2851 Dado Set, 10" dia. x 13/16" wide x 1" arbor hole.
T-2852 Dado Set, 12" dia. x 13/16" wide x 1" arbor hole.

DADO SETS AND ACCESSORIES

for dadoing, grooving, rabbeting, mortising, and tenoning.

CHIPPERS FOR DADO HEADS

T-2806 Chipper, 8" dia. x 1/16" thick x 1" arbor hole.

T-2808 Chipper, 8" dia. x 1/8" thick x 1" arbor hole.

T-2807 Chipper, 8" dia. x 1/4" thick x 1" arbor hole.

T-2814 Chipper, 10" dia. x 1/16" thick x 1" arbor hole.

T-2815 Chipper, 10" dia. x 1/8" thick x 1" arbor hole.

T-2816 Chipper, 10" dia. x 1/4" thick x 1" arbor hole.

T-2819 Chipper, 12" dia. x 1/16" thick x 1" arbor hole.

T-2820 Chipper, 12" dia. x 1/8" thick x 1" arbor hole.

T-2821 Chipper, 12" dia. x 1/4" thick x 1" arbor hole.

Accessories for 16" & 18" radial arm saws

KNIVES FOR SHAPING HEADS, ETC.

KNIVES — sets of 2-self aligning 1/4"-3/8" thick, high speed steel with one hole and held in head by 1/4" dia. filister head socket screws.

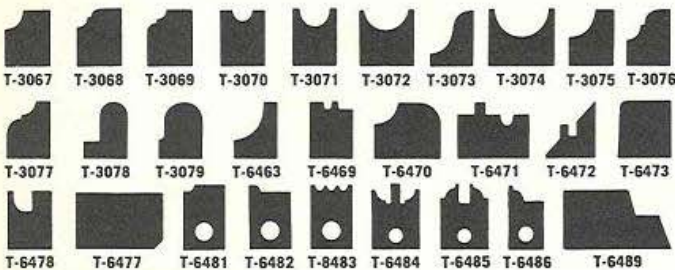

- T-3067 3/8" Quarter Round Knives.
- T-3068 3/16" Bead and 3/16" Cove Knives.
- T-3069 3/16" Cove and 3/16" Bead Knives.
- T-3070 Nosing Cutter, 7/16" Nose Knives.
- T-3071 Nosing Cutter, 3/8" Nose Knives.
- T-3072 Nosing Cutter, 15/16" Nose Knives.
- T-3073 Ogee Mould, 7/16" Bead and Cove (comb.).
- T-3074 Nosing Cutter, 1 1/4" Nose Knives.
- T-3075 3/8" Quarter Round Knives.
- T-3076 5/16" Bead and 5/16" Cove Knives.
- T-3077 5/16" Cove and 5/16" Bead Knives.
- T-3078 Fluting Cutter 5/16 Knives.
- T-3079 Fluting Cutter, 7/16" Knives.
- T-6463 3/4" Quarter Round Knives, Series No. 8065.
- T-6469 Glue Joint Knives.
- T-6470 Drop Leaf Table, Combination Knives.
- T-6471 Tongue and Groove 1" Flooring Comb.
- T-6472 Miter Lock Joint Combination Knives.
- T-6473 Panel Raising Knives.
- T-6478 Cupboard Door Lip, 3/8" radius 7° rake.
- T-6477 2" Jointing, surfacing and panel raising.
- T-6481 Sticking Mould Shape Knives.
- T-6482 Cope-Long Tenon Knives.
- T-6483 Screen Mold Knives.
- T-6484 Sticking Knives for 1 3/8" stock.
- T-6485 Full Cope Knives for 1 3/8" stock.
- T-6486 Cope-Long Tenon Knives.
- T-6489 Cupboard Door Lip Knives, straight 7° rake.

SHAPING & JOINTING HEADS & HEAD SETS

T-6474 Two-Knife Shaper Head, 5" long x 1 1/2" wide x 7/8" thick x 1" arbor hole.



T-6456 Four-Knife Shaper Head, 4" dia. x 7/8" thick x 1" arbor hole (requires 2 sets of knives).

COUNTER BORED HEADS AND ACCESSORIES

for shaping, dadoing, rafter-notching, jointing, and scarf-cutting.

T-68730 Rafter Notching Set. Includes counter bored four-knife head, 5" dia. x 1 1/2" wide x 1" arbor hole, and four each T-6365 straight knife and T-7155 spur knife.



T-68745 Counter bored four knife head, 9" dia. x 2" long x 1" arbor hole. Complete with T-68743 Knife Keepers and Jack Screws. Uses 1/2" thick knives.

T-6365 Straight Knives, set of four, 2" long x 1 1/2" wide x 5/16" thick (for T-68730).

T-7155 Rafter Notching Spur Knives, set of four (for T-68730).

T-6387 Piggyback Spur Knives, left hand, set of four, with attaching screws (for T-68745).

T-6388 Piggyback Spur Knives, right hand, set of four, with attaching screws (for T-68745).

T-6399 Straight Knives, set of four, 2" long x 1 3/4" wide x 1/2" thick, tapped for piggyback spur knives (for T-68745).

T-6400 Straight Knives, set of four, 3" long x 1 3/4" wide x 1/2" thick, tapped for piggyback spur knives (for T-68745).

T-6401 Straight Knives, set of four, 4" long x 1 3/4" wide x 1/2" thick, tapped for piggyback spur knives (for T-68745).

T-54034 Arbor Nut Socket Wrench.

T-204005 Spacing Collar, 2" dia. x 1-7/16" thick x 1" arbor hole.

T-68743 Knife Keepers, set of four, with jack screws (for T-68745).

RADIAL ARM SAW BLADES



Cat. No.	Size	Type	Arbor Size	No. of Teeth	Thickness	Quality
T-2002	16"	Combination, Flat Ground	1"	72	13	Premium
T-2007	16"	Combination, Flat Ground	1"	100	13	Select
T-2206	16"	Planer, Hollow Ground	1"	110	11	Premium
T-2226	16"	Planer, Hollow Ground	1"	110	11	Select
T-2303	16"	Rip, Flat Ground	1"	32	13	Premium
T-2307	16"	Rip	1"	36	13	Select
T-2502	16"	Combination, Carbide Tipped	1"	16	11	Select
T-2506	16"	Rip, Carbide Tipped	1"	16	11	Select
T-2602	16"	Combination, Carbide Tipped	1"	45	10	Premium
T-2606	16"	Rip, Carbide Tipped	1"	40	11	Premium
T-2003	18"	Combination	1"	78	12	Premium
T-2008	18"	Combination, Flat Ground	1"	110	13	Select
T-2207	18"	Planer, Hollow Ground	1"	120	10	Premium
T-2227	18"	Planer, Hollow Ground	1"	120	10	Select
T-2304	18"	Rip	1"	32	12	Premium
T-2308	18"	Rip, Flat Ground	1"	36	12	Select
T-2503	18"	Combination, Carbide Tipped	1"	18	10	Select
T-2507	18"	Rip, Carbide Tipped	1"	18	10	Select
T-2603	18"	Combination, Carbide Tipped	1"	54	10	Premium
T-2607	18"	Rip, Carbide Tipped	1"	40	10	Premium
T-2004	20"	Combination	1"	84	12	Premium
T-2305	20"	Rip	1"	32	12	Premium
T-2005	22"	Combination	1"	90	12	Premium

Accessories for 14" radial arm saw

SAFETY ATTACHMENTS

T-1761 14" Safety Guard Conversion Kit—for converting standard saw guard to automatic safety guard—free floating device adjusts automatically to depth of cut and fully covers the exposed saw blade.

T-1763 Splitter and Anti-Kickback Device for 14" Guard.

T-1748 Universal Tool Guard—adjustable front and rear sections—used with shaping heads.

T-1749 Dado Guard, 2½" wide

T-1750 Dado Guard, 4" wide.

T-116600 SAF-T-BAK. Automatic safety return device automatically returns roller head to rear of guide fence. Also eliminates creeping of saw blade when idling.



POWER RIP FEED

T-1736 Safety Power Rip Feed with 115 volt, ¼ HP, 1725 RPM motor with variable speed control of 0 to 90 feet per minute.



DYNAMIC POWER BRAKE—stops saw blade in seconds. Operates from push-button station. Replaces standard starter.

T-201478-05 Power Brake for 3 HP, 1 phase, 230 volts or 3 and 5 HP, 3 phase, 220 volts, 50/60 cycles.

T-201478-06 Power Brake for 3 and 5 HP, 440 volt, 3 phase, 50/60 cycle.



ROLLER EXTENSION TABLE AND ACCESSORIES

40030 Roller Extension Table, 17" wide x 8' long. Includes eight rollers. Uses T-1735 Support Legs.

T-1735 Adjustable Support Legs for roller extension table.

T-1743 Cut-off Gauge, 10 feet, left to right. With one automatic adjustable stop.

T-1744 Cut-off Gauge, 10 feet, right to left. With one automatic adjustable stop.

T-1745 Automatic Adjustable Stop.



SPACING COLLARS

T-2413 Spacing Collar 1/16" thick x 1" arbor hole.

T-2414 Spacing Collar ¼" thick x 1" arbor hole.

T-2415 Spacing Collar ½" thick x 1" arbor hole.

T-2420 Spacing Collar ¾" thick x 1" arbor hole.

T-2426 Spacing Collar 1" thick x 1" arbor hole.



SUPPORT COLLARS

T-2214 6" Steel Support Collars—set of two.

DADO SETS AND ACCESSORIES

— for dadoing, grooving, rabbeting, mortising, and tenoning.

FLAT GROUND NO. 3 DADO SETS—consisting of two each ⅜" outside blades, two ⅜" inside chippers, one ¼" inside chipper, and one 1/16" inside chipper.

T-2853 Dado Set, 8" dia. x 13/16" wide x 1" arbor hole.

T-2854 Dado Set, 10" dia. x 13/16" wide x 1" arbor hole.

HOLLOW GROUND NO. 3 DADO SET—consisting of two each ⅜" outside blades, two ⅜" inside chippers, one ¼" inside chipper, and one 1/16" inside chipper.

T-2850 Dado Set, 8" dia. x 13/16" wide x 1" arbor hole.

T-2851 Dado Set, 10" dia. x 13/16" wide x 1" arbor hole.



INSIDE CHIPPERS FOR DADO SETS

T-2806 Chipper, 8" dia. x 1/16" thick x 1" arbor hole.

T-2808 Chipper, 8" dia. x 1/8" thick x 1" arbor hole.

T-2807 Chipper, 8" dia. x ¼" thick x 1" arbor hole.

T-2814 Chipper, 10" dia. x 1/16" thick x 1" arbor hole.

T-2815 Chipper, 10" dia. x ⅜" thick x 1" arbor hole.

T-2816 Chipper, 10" dia. x ¼" thick x 1" arbor hole.

SHAPING HEADS AND KNIVES

T-6474 Two-Knife Shaper Head, 5" long x 1½" wide x ⅞" thick x 1" arbor hole.

T-6456 Four-Knife Shaper Head, 4" dia. x ⅞" thick x 1" arbor hole (requires 2 sets of knives).

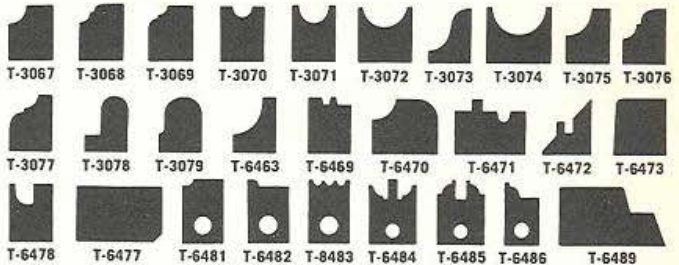

Knives—sets of 2-self aligning ¼"-⅜" thick, high speed steel with one hole and held in head by ¼" dia. filister head socket screws.

T-3067 ⅜" Quarter Round Knives.

T-3068 3/16" Bead and 3/16" Cove Knives.

T-3069 3/16" Cove and 3/16" Bead Knives.

T-3070 Nosing Cutter, 7/16" Nose Knives.

T-3071 Nosing Cutter, ⅝" Nose Knives.

T-3072 Nosing Cutter, 15/16" Nose Knives.

T-3073 Ogee Mould, 7/16" Bead and Cove (comb.).

T-3074 Nosing Cutter, 1¼" Nose Knives.

T-3075 ⅝" Quarter Round Knives.

T-3076 5/16" Bead and 5/16" Cove Knives.

T-3077 5/16" Cove and 5/16" Bead Knives.

T-3078 Fluting Cutter 5/16" Knives.

T-3079 Fluting Cutter 7/16" Knives.

T-6463 ¾" Quarter Round Knives, Series No. 8065.

T-6469 Glue Joint Knives.

T-6470 Drop Leaf Table, Combination Knives.

T-6471 Tongue and Groove 1" Flooring Comb.

T-6472 Miter Lock Joint Combination Knives.

T-6473 Panel Raising Knives.

T-6478 Cupboard Door Lip, ⅜" radius 7° rake.

T-6477 2" Jointing, surfacing and panel raising.

T-6481 Sticking Mould Shape Knives.

T-6482 Cope-Long Tenon Knives.

T-6483 Screen Mold Knives.

T-6484 Sticking Knives for 1⅜" stock.

T-6485 Full Cope Knives for 1⅜" stock.

T-6486 Cope-Long Tenon Knives.

T-6489 Cupboard Door Lip Knives, straight 7° rake.

RADIAL ARM SAW BLADES

Cat. No.	Size	Type	Arbor Size	No. of Teeth	Thickness	Quality
T-2204	12"	Planer, Hollow Ground	1"	90	12	Premium
T-2301	12"	Rip, Flat Ground	1"	32	13	Premium
T-2500	12"	Combination, Carbide Tipped	1"	12	13	Select
T-2504	12"	Rip, Carbide Tipped	1"	12	13	Select
T-2600	12"	Combination, Carbide Tipped	1"	30	12	Premium
T-2604	12"	Rip, Carbide, Tipped	1"	40	11	Premium
T-2001	14"	Combination, Flat Ground	1"	66	13	Premium
T-2006	14"	Combination, Flat Ground	1"	90	13	Select
T-2205	14"	Planer, Hollow Ground	1"	100	11	Premium
T-2210	14"	Planer, Hollow Ground	1"	100	11	Select
T-2302	14"	Rip, Flat Ground	1"	32	13	Premium
T-2306	14"	Rip, Flat Ground	1"	36	13	Select
T-2501	14"	Combination, Carbide Tipped	1"	14	11	Select
T-2505	14"	Rip, Carbide Tipped	1"	14	12	Select
T-2601	14"	Combination, Carbide Tipped	1"	36	11	Premium
T-2605	14"	Rip, Carbide Tipped	1"	40	11	Premium



Accessories for 10" & 12" radial arm saws



CONVERSION KITS

T-1509 10" Guard Conversion Kit— for converting standard guard to automatic safety guard.

T-1508 12" Guard Conversion Kit.

SAF-T-BAK — AUTOMATIC SAFETY RETURN



T-1816 SAF-T-BAK for 10" Saws — Automatic Safety Return Device. Automatically returns saw blade and motor to rear of guide fence. Eliminates creeping of blade when idling.

T-1506 SAF-T-BAK for 3430, 3435, T-1531, T-1533

SPLITTER AND KICK-BACK



T-1516 Splitter and Anti-Kick-back Device for 10" Saw Guard — splitter separates wood when ripping — prevents saw bind.

T-1818 Splitter and Anti-Kick-back Device for 12".

SHAPER - JOINTER FENCE



T-1815 Shaper-Jointer Fence — for fencing and jointing operations. Has micrometer adjustments from 0 to 1/2".



TOOL GUARD

T-1814 Tool Guard — for all horizontal shaping, dadoing, disc sanding and sawing operations. Will accommodate tools up to 8" dia.



LEG STAND

T-1806 Leg Stand for Model 3420 and former Model T-1810.

TABLE TOP

T-40181 Magic Miter Table Top — permits accurate cross-cuts, right and left miter cuts without moving arm. Fits Model 3420 (T-1812) and former Model T-1810.



RADIAL ARM SAW BLADES

Cat. No.	Size	Type	Arbor Size	No. of Teeth	Thickness	Quality
T-2918	8"	Combination Cabinet Thin Rim	5/8"	52		Select
T-2919	8"	Plywood Veneer	5/8"	176		Select
T-2921	8"	Plywood, Hollow Ground	5/8"	180		Select
T-2228	9"	Planer, Hollow Ground 4 cutter, 1 raker	5/8"	65		Premium
T-2230	9"	Planer, Hollow Ground 4 cutter, 1 raker	5/8"	70		Select
T-2508	9"	Combination Carbide Tip	5/8"			Premium
T-2113	9"	Combination Chisel	5/8"	28		Premium
T-2108	9"	Combination Chisel	5/8"	28		Select
T-2012	9"	Combination Novelty	5/8"	48		Premium
T-2312	9"	Rip	5/8"	32		Premium
T-2009	9"	Combination Novelty	5/8"			Select
T-2309	9"	Rip	5/8"	36		Select
T-2010	10"	Combination, Flat Ground	5/8"	60	15	Select
T-2013	10"	Combination, Flat Ground	5/8"	54	15	Premium
T-2109	10"	Combination, Flat Ground	5/8"	30	15	Select
T-2114	10"	Combination, Flat Ground	5/8"	30	15	Premium
T-2229	10"	Planer, Hollow Ground	5/8"	15	13	Select
T-2231	10"	Planer, Hollow Ground	5/8"	80	13	Premium
T-2310	10"	Rip	5/8"	36	15	Select
T-2313	10"	Rip	5/8"	36	15	Premium
T-2509	10"	Combination, Carbide Tipped	5/8"	8	13	Select
T-2608	10"	Combination, Carbide Tipped	5/8"	24	13	Premium
T-2610	10"	Planer, Carbide Tipped	5/8"	50	12	Premium
T-2611	10"	Rip, Carbide Tipped	5/8"	24	13	Premium
T-2920	10"	Plywood Veneer	5/8"	38	13	Select
T-2922	10"	Plywood Veneer	5/8"			Premium
T-2011	12"	Combination, Flat Ground	5/8"	60	13	Select
T-2014	12"	Combination, Flat Ground	5/8"	60	13	Select
T-2112	12"	Combination, Chisel Tooth	5/8"	38	13	Select
T-2115	12"	Combination, Chisel Tooth	5/8"	38	13	Premium
T-2311	12"	Rip	5/8"	32	13	Select
T-2314	12"	Rip	5/8"			Premium
T-2510	12"	Combination, Carbide	5/8"	12	12	Select
T-2609	12"	Combination, Carbide	5/8"	30	11	Premium

call your *Black & Decker* / **DEWALT** distributor... he's our partner in service

The best way to serve the best interests of all our Black & Decker/DeWalt tool users is locally . . . and we do it best through technically experienced, conveniently located distributors. It's a kind of partnership created to make certain that whatever you need in power tools is only minutes away.

Consider the advantages this kind of partnership gives you:

- By purchasing the tools you need from well-stocked distributors you avail yourself of a single centralized source of supply for the latest in quality products;
- Service is immediate, personal and backed by expert knowledge of tool applications and the distributor's reputation;
- When you need technical answers, you get them fast;
- When you need equipment, you get it quickly and economically;
- The distributor's warehouse becomes an additional equipment storehouse for you . . . without added overhead;
- Your transportation costs, inventory costs, purchasing and accounting costs are minimized;
- You buy from the latest price sheets with complete catalog information to help you make the right selection . . . and you buy with superior credit facilities.

For many years, we have maintained this kind of partnership to serve you best. That's why it makes sense to make purchases through your local distributor.

NO-TIME LIMIT QUALITY GUARANTEE



Black & Decker will correct, without charge, any defect at any time which, upon examination at one of our factory service branches, authorized service stations, or factories, is found to be due to faulty material or workmanship. The guarantee does not apply in cases of misuse or careless handling or where repairs or replacements have been made or attempted by others. Any transportation charges for delivering the unit for examination must be prepaid.

Introducing Black & Decker's new catalog numbering system

As of January 1, 1970 Black & Decker has established a completely new numbering system for all tools manufactured or marketed in U. S. operations.

Each tool and each variation in speed, handle design, voltage or drive-end etc., is provided with a distinctive unique number which distinguishes it from any other tool of our manufacture.

In addition to its pin-point accuracy in model identification and its adaptability to computer operations, the new numbering system is compatible with the "Standard Numbering System" sponsored by the National Industrial Distributors Association and other related organizations.

This catalog identifies all tools by their new numbers, with reference to the former model number shown in the specification tables on each page.

For your convenience a cross-reference table listing "New to Old" and "Old to New" catalog numbers appears at the right.



DEWALT.

cross-reference chart— new numbers to old

New No.	Old No.
3420	T-1812
3430	T-1531
3435	T-1533
3480	T-483-12
3485	T-583-12
3500	GAN-S
3505	GAN-M
3510	GAO-S
3515	GAO-M
3520	GAR-S
3525	GAR-M
3530	T-1631
3535	T-1633
3580	T-1670

cross-reference chart— old numbers to new

Old No.	New No.
GAO-S	3510
GAO-M	3515
GAN-S	3500
GAN-M	3505
GAR-S	3520
GAR-M	3525
T-483-12	3480
T-583-12	3485
T-1531	3430
T-1533	3435
T-1631	3530
T-1633	3535
T-1670	3580
T-1812	3420

prompt efficient service

To assure you prompt, efficient service on Black & Decker Products, there are over 100 Service Centers at strategic points throughout the United States and Canada. These are equipped with genuine Black & Decker replacement parts and use factory-approved methods. When you need "Quality B&D Service," you will find a Black & Decker Service Facility within 24 hours of you, ready to serve you expertly, reasonably and promptly.

Don't forget Black & Decker's other product lines. See your nearest Black & Decker Distributor for catalogs covering a complete line of Automotive Power Tools

FACTORY SALES and SERVICE CENTERS

	Area Code	Telephone No.		Area Code	Telephone No.
ALABAMA: Birmingham 35233, 1717 Third Ave., South.....	205	324-6691	NEW JERSEY: Newark 07104, 868 Broadway.....	201	HU 3-1076
ARIZONA: Phoenix 85004, 537 E. McDowell Rd.....	602	AL 8-1332	NEW MEXICO: Albuquerque 87110, 4700 Lomas Blvd. N.E.....	505	265-6401
ARKANSAS: Little Rock, 72201, 519 West Seventh Street.....	501	FR 2-3040	NEW YORK: Buffalo 14209, 881 W. Delavan Ave.....	716	TT 4-6220
CALIFORNIA: Anaheim 92802, 1235 So. Euclid Ave.....	714	772-4050	New York 10462, 1894 E. Tremont Avenue (Bronx).....	212	SY 2-2700
Los Angeles 90007, 2432 S. Broadway.....	213	RI 9-0371	New York 10014, 227 Varick St. (Manhattan).....	212	WA 9-6450
Oakland 94606, 1107 E. 14th St.....	415	TE 4-5944	New York 11377, 56-15 Queens Blvd. (Woodside).....	212	DE 5-1042
Sacramento 95814, 1915 Seventeenth Street.....	916	444-3188	Rochester 14620, 476 Clinton Ave. S.....	716	454-3814
San Diego 92105, 3811 El Cajon Blvd.....	714	AT 1-3331	Syracuse 13224, 2140 Erie Blvd. E.....	315	446-3086
San Francisco 94080, 1139 Airport Blvd.....	415	871-7278	NORTH CAROLINA: Charlotte 28206, 1710 N. Graham St.....	704	FR 5-3721
Santa Clara 95050, 2291 The Alameda.....	408	241-9162	Fayetteville 28306, P.O. Box 4305, Highway 301, S.....	919	425-1181
Van Nuys 91401, 14920 Victory Blvd.....	213	787-5531	Greensboro 27403, 1008 W. Lee Street.....	919	275-0906
COLORADO: Denver 80204, 675 Kalamath St.....	303	222-0621	OHIO: Cincinnati 45203, 1225 Western Ave.....	513	421-2275
CONNECTICUT: Hartford 06114, 131 Meadow Street.....	203	249-6241	Cleveland 44113, 3901 Detroit Ave.....	216	OL 1-4243
FLORIDA: Jacksonville 32208, 5224 Pearl Street.....	904	356-2951	Columbus 43202, 3293 N. High Street.....	614	263-8884
Miami 33142, 2075 N. W. 54th Street.....	305	NE 3-9839	Dayton 45420, 617 Watervliet Street.....	513	252-1821
Orlando 32806, 940 So. Orange Ave.....	305	423-1651	Solon 44139, 6225 Cochran Road.....	216	CH 8-5330
Tampa 33609, 3401 W. Kennedy Blvd.....	813	872-8317	Toledo 43606, 2629 W. Central Ave.....	419	475-6771
GEORGIA: Atlanta 30313, 316 Techwood Drive, N.W.....	404	JA 4-0431	OKLAHOMA: Oklahoma City 73106, 1318 Linwood Blvd.....	405	CE 2-7515
HAWAII: Honolulu 96813, 675 Auahi Street.....	808	536-9374	Tulsa 74145, 3120 South Sheridan Road.....	918	622-5661
ILLINOIS: Chicago 60607, 1100 W. Jackson Blvd.....	312	TA 9-3500	OREGON: Portland 97209, 1640 N. W. Johnson Street.....	503	CA 8-8631
Chicago 60646, Lincolnwood, 6710 N. Crawford Ave.....	312	OR 3-0923	PENNSYLVANIA: Harrisburg 17112, 6070 Allentown Blvd.....	717	KI 5-0651
Chicago 60643, Beverly Hills, 10708 S. Western Ave.....	312	BE 3-6832	Lancaster 17604, 715 Fountain Ave.....	717	393-5831
Rock Island 61201, 725 30th Street.....	309	788-1744	Philadelphia 19103, 333 No. 20th Street.....	215	LO 4-5520
INDIANA: Evansville 47708, 931 Bond Street.....	812	425-4269	Pittsburgh 15232, 5437 Baum Blvd.....	412	362-2700
Indianapolis 46202, 1125 W. 16th Street.....	317	632-5569	RHODE ISLAND: E. Providence 02914, 2777 Pawtucket Ave.....	401	434-1655
IOWA: Des Moines 50312, 2811 Ingersoll Ave.....	515	CH 4-7257	SOUTH CAROLINA: Greenville 29601, 407 Pendleton St.....	803	232-3038
KANSAS: Wichita 67214, 203 N. Mathewson Street.....	316	FO 3-6571	TENNESSEE: Knoxville 37917, 1123 North Central St.....	615	546-2481
KENTUCKY: Louisville 40209, 4407 Park Blvd.....	502	366-1495	Memphis 38116, 986 East Brooks Rd.....	901	332-3444
LOUISIANA: New Orleans 70002, 3310 N. Causeway Blvd.....	504	837-2550	Nashville 37203, 601 Eighth Ave. S.....	615	254-1061
MARYLAND: Baltimore 21211, 203 West 28th Street.....	301	HO 7-7411	TEXAS: Amarillo 79106, 3008 West 6th Ave.....	806	DR 3-1531
Baltimore 21205, 4712 Erdman Ave.....	301	485-5550	Dallas 75207, 1808 N. Industrial Blvd.....	214	RI 1-6401
Bladensburg 20710, 4501 Baltimore Avenue.....	301	779-3808	Fort Worth 76103, 1801 Bomar Street.....	817	ED 6-0175
MASSACHUSETTS: Boston 02135, 12 Market St. (Brighton).....	617	ST 2-6264	Houston 77003, 105 Sampson Street.....	713	CA 8-7521
MICHIGAN: Detroit 48219, 18133 W. McNichols Rd.....	313	534-8880	San Antonio 78210, 1314 S. St. Mary's Street.....	512	LE 4-4611
Detroit 48234, 11360 East Seven Mile Road.....	313	527-5010	UTAH: Salt Lake City 84115, 1541 S. Second West Street.....	801	HU 6-7056
Grand Rapids 49509, 3662 Clyde Park Ave., S.W.....	616	534-7708	VIRGINIA: Falls Church 22046, 129 Annandale Road.....	703	533-1147
MINNESOTA: Minneapolis 55408, 2815 Nicollet Ave.....	612	TA 3-5283	Norfolk 23517, 337 W. 21st Street.....	703	625-6888
MISSOURI: Kansas City 64108, 2705 McGee Trafficway.....	816	HA 1-1493	Richmond 23222, 1424 Chamberlayne Ave.....	703	649-9245
St. Louis 63110, 615 S. Vandeventer Ave.....	314	JE 3-2210	WASHINGTON: Seattle 98109, 434 Eighth Ave., N.....	206	MA 3-6442
NEBRASKA: Omaha 68102, 2218 Leavenworth Street.....	402	345-2330	Spokane 99202, 3025A E. Mission Ave.....	509	KE 4-7188
			WEST VIRGINIA: Charleston 25312, 1638 Sixth Ave.....	304	343-0289
			WISCONSIN: Milwaukee 53213, 6301 Blue Mound Road.....	414	GR 6-7800

BLACK & DECKER MFG. CO., Limited, Canada

BROCKVILLE, ONTARIO; CALGARY, ALBERTA; DON MILLS (Toronto) ONTARIO; EDMONTON, ALBERTA; HALIFAX, NOVA SCOTIA; HAMILTON, ONTARIO; LONDON, ONTARIO; MONTREAL 10, P. Q.; OTTAWA, ONTARIO; QUEBEC CITY, P. Q.; REGINA, SASKATCHEWAN; SASKATOON, SASKATCHEWAN; VANCOUVER 10, B. C.; WINNIPEG 10, MANITOBA

AUTHORIZED SERVICE STATIONS

ALABAMA, Montgomery, ALASKA, Anchorage, Fairbanks, ARIZONA, Tucson, CALIFORNIA, Fresno, Stockton, CONNECTICUT, New Haven, DELAWARE, Wilmington, FLORIDA, Pensacola, IDAHO, Boise, Lewiston, MAINE, Westbrook, MISSISSIPPI, Jackson, NEVADA, Reno, Las Vegas, NEW YORK, Schenectady, OHIO, Youngstown, PENNSYLVANIA, Allentown, Erie, SOUTH CAROLINA, Charleston, SOUTH DAKOTA, Rapid City, TEXAS, Corpus Christi, El Paso, VIRGINIA, Roanoke, WASHINGTON, Yakima, WEST VIRGINIA, Wheeling

DISTRIBUTION CENTERS

CALIFORNIA 94804, Richmond, 1732 Wright Ave., Phone: 415 235-4232
CONNECTICUT 06051, New Britain, 595 John Downey Drive, Phone: 203 225-8415
GEORGIA 30354, Atlanta, 3271 Hamilton Blvd. S. W., Phone: 404 761-8031 - 2
ILLINOIS 60018, Des Plaines, 2180 S. Wolf Road, Phone: 312 827-7145
(Sales Office: 312 827-0083)
MARYLAND 21074, Hampstead, Phone: 301 374-9046
MISSOURI 64116, N. Kansas City, 1343 Murray Drive, Phone: 816 VI 2-6350

MANUFACTURING PLANTS

Fayetteville, North Carolina; Lancaster, Pa.; Solon, Ohio; Towson, Md., Hampstead, Md., U.S.A.; Brockville, Ontario, Can.; Harmondsworth, Middx., Maidenhead, Spennymoor, England; Croydon, Vic., Australia; Lyon, France; Milan, Italy

SALES AND SERVICE SUBSIDIARIES

Vienna, Austria; Brussels, Belgium; Copenhagen, Denmark; Helsinki, Finland; Athens, Greece; Tokyo, Japan; Mexico, D. F., Monterrey, Guadalajara, Mexico; Rotterdam, Netherlands; Auckland, Wellington, Christchurch, New Zealand; Grouard, Norway; Johannesburg, Cape Town, Durban, South Africa; Barcelona, Spain; Goteborg, Sweden; Zurich, Switzerland; Caracas, Venezuela, Idstein, Germany

BLACK & DECKER, INC., Urbanizacion Industrial Julia Caparra Heights, San Juan, Puerto Rico

60TH
ANNIVERSARY



expect the best from
Black & Decker
POWER TOOLS

DEWALT

The BLACK & DECKER Manufacturing Co.
Towson, Maryland 21204 U.S.A.