

INSTRUCTIONS FOR ASSEMBLING AND INSTALLING CRAFTSMAN PEDESTAL TYPE TOOL STAND CATALOG NO. 9-29602

FOR USE WITH CRAFTSMAN JOINTERS CATALOG NOS. 2061 and 2062

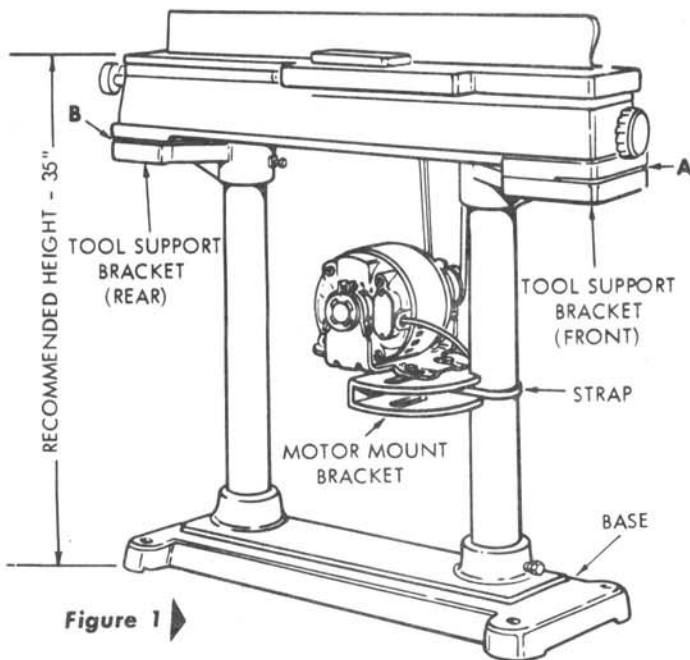

Figure 1 ▶

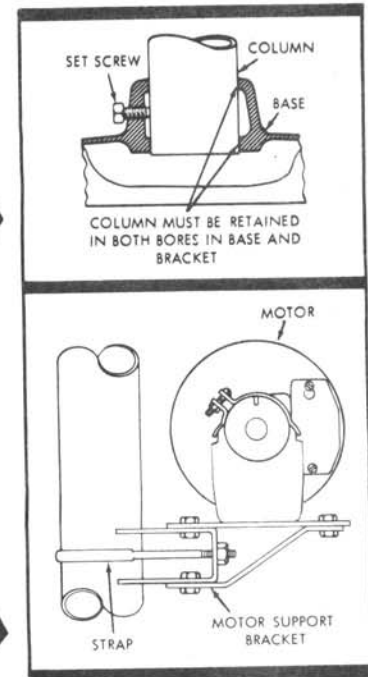

Figure 2 ▶

Figure 3 ▶

This Dual-Pedestal Type Tool Stand provides a convenient support for the Craftsman Jointers listed above. The base contains four holes for permanently attaching the stand to the floor, or for installation of casters (Catalog No. 2819) if mobility of the jointer is desired. Assemble the stand and mount the jointer in accordance with the following instructions.

1. Place the base on the floor and loosen the set screw at each column bore enough to permit insertion of the columns into the base. (See figure 2.)
2. Insert each column into the base far enough to make full contact with both machined bores. (See figure 2.) The columns may be raised or lowered a short distance in the base to provide a height adjustment. However, they must not be raised out of contact with the lower bore and both columns must be inserted the same distance into the bore.
3. Hold each column at the proper position and tighten the set screw securely.
4. Attach the motor loosely to the motor support bracket and insert the retainer strap into the bracket. (See figure 3.) Slide the assembled motor and support over one of the columns (shown in figure 1) and locate it at the approximate motor mounting position. Tighten the strap nuts just enough to hold the motor support temporarily in position.

NOTE: The motor support bracket is constructed with the v-slot off center. The wide portion of the bracket should be at the right (when facing the tool in operating position) to allow sufficient motor adjustment to proper pulley alignment.

5. Place both tool support brackets on upper end of columns, parallel with base, and secure both supports by tightening the set screws.

CAUTION: Top (mounting) surfaces of the supports (shown at A and B, figure 1) must be at a uniform height from the floor to permit proper mounting of jointer.

6. Install the jointer on the tool stand, using the 5/16-18 x 1-3/4 inch square head bolts, washers and square nuts provided.
7. Place the drive belt on jointer pulley and motor pulley and adjust belt tension and alignment as follows:
 - a. Position the motor laterally until both pulleys are in the same plane. Tighten motor attaching bolts.
 - b. Loosen strap nuts and move entire motor support up or down on the column to provide proper belt tension. Belt tension is correct when light finger pressure midway between pulleys deflects the belt approximately 1/4 inch.

AVAILABLE ACCESSORIES

The following accessories for this tool stand and jointer may be purchased from the nearest Sears Retail Store or Mail Order House.

1. Four Casters (Catalog No. 2819) to provide mobility of the stand.
2. Belt Guard (Catalog No. 2908) for protection against the moving belt. A 37-inch belt is required when the guard is used.

SEARS, ROEBUCK AND CO.—U. S. A.
IN CANADA, SIMPSONS-SEARS LIMITED