

PARTS LIST FOR CRAFTSMAN DRILL PRESS

MODEL NUMBER 101.03662

This is the Model Number of your Drill Press. It will be found on the rear center of the Base Top. Always mention this Model Number when communicating with us regarding your Drill Press or when ordering Parts.

CONFIDENTIAL INFORMATION FOR RETAIL AND MAIL ORDER STORES

1. Ordering Instructions — Send all orders for parts listed herein direct to:

ATLAS PRESS COMPANY
Kalamazoo, Michigan

Parts will be shipped prepaid either to your store or direct to the customer.

A minimum charge of 25c will be made by the source on any order amounting to less than 25c; but the customer is to be charged the actual selling price as shown on the parts list.

2. Mark-up — Selling prices on the parts listed produce a mark-up of approximately C3.

FILING INSTRUCTIONS

Remove and destroy parts list Model Number 101.03662 in your Division 9 Standard Nomenclature Grey Binder. File this list in its place.

SEARS, ROEBUCK AND CO.

HOW TO ORDER PARTS FOR CRAFTSMAN DRILL PRESS

MODEL NUMBER 101.03662

All parts listed here may be ordered through any Sears retail store or the mail order store which serves the territory in which you live. When ordering, always give the following:

1. Part number in this list.
2. Part name and price in this list.
3. Model number, which is 101.03662, and which will be found on the plate on the rear center of the base top.

ALL PARTS ARE SHIPPED PREPAID

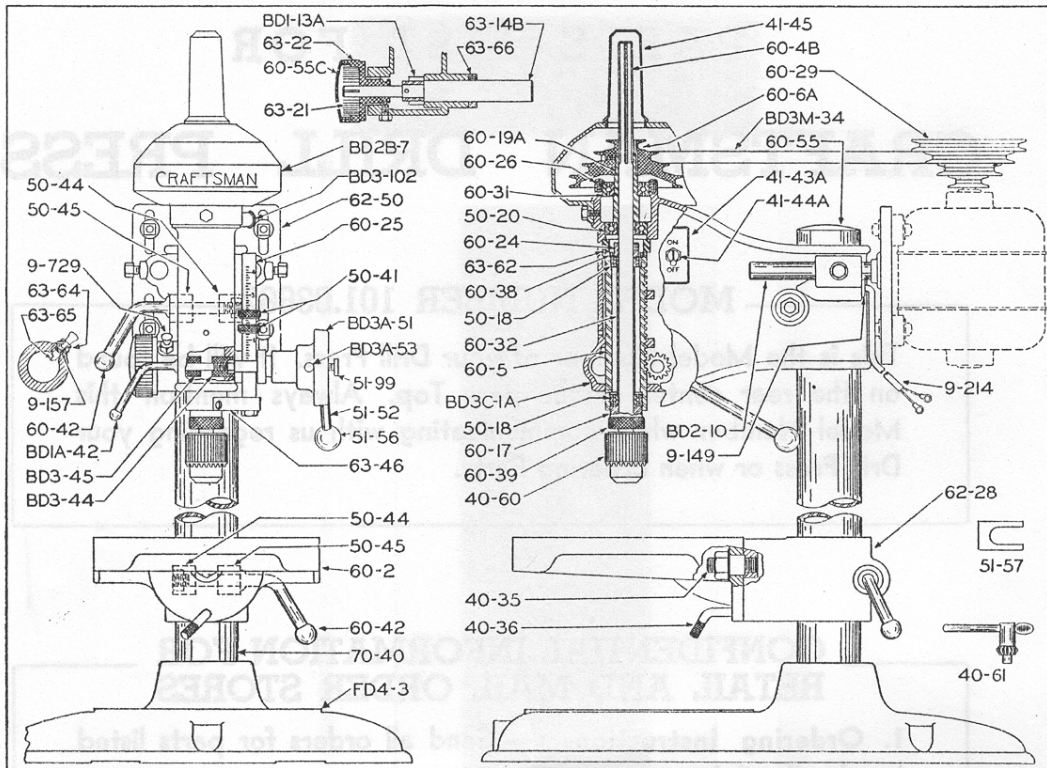

PARTS LIST

Part No.	PART NAME	Selling Price Each	Part No.	PART NAME	Selling Price Each			
HEAD ASSEMBLY								
BD3C-1	Head	\$ 6.90	60-2	Table	\$ 5.75			
60-4B	Spined Spindle	2.50	62-28	Table Bracket	2.20			
60-5	Spindle Quill	3.25	40-35	Table Pilot Stud	.40			
60-6A	Spindle Pulley	1.55	40-36	Table Lock Pin	.30			
BD2B-7	Spindle Pulley Guard	1.20	60-42	Clamp Handle	.75			
63-14A	Spindle Feed Pinion Shaft and Pinion	2.25	50-44	Column Lock	.30			
60-17	Chuck Release Collar	.55	50-45	Column Lock Sleeve	.40			
50-18	Spindle Quill Bearing (2 req.) each	2.05	*Table Assembly complete			8.85		
60-19A	Spindle Pulley Sleeve	2.40	MOTOR BASE ASSEMBLY					
50-20	Spindle Pulley Sleeve Bearing (small)	2.40	BD2-10	Motor Base Pin (2 req.) each	.40			
63-21	Feed Lever Balance Spring	.60	62-50	Motor Base	1.25			
63-22	Feed Lever Balance Spring Housing	1.25	*Motor Base Assembly Complete			1.90		
60-24	Upper Spindle Collar	.40	BASE					
60-25	Feed Stop Stud	1.25	FD4-3	Base	9.40			
60-26	Spindle Pulley Bearing Plate	.40	MISCELLANEOUS					
60-31	Spindle Pulley Sleeve Bearing (large)	2.90	60-29	Motor Pulley	1.55			
60-32	Spindle Bearing Spacer	.45	BD3M-34	Belt	1.50			
60-38	Spindle Bearing Lock Nut	.30	70-40	Column	9.00			
60-39	Chuck Release Nut	.40	60-55	Column Cap	.55			
50-41	Feed Stop Stud Nut (2 req.) each	.40	51-57	Chuck Release Wedge	.20			
60-42	Clamp Handle	.75	40-60	Drill Chuck 0" to 1/2"	8.45			
BD1A-42	Small Clamp Handle	.55	40-61	Drill Chuck Wrench	.55			
41-43	Switch Plate	.25	Sears, Roebuck and Company Enclosed find my check for \$3.25 for which please send me by parcel post the following parts for my Craftsman Drill Press, Model Number 101.03662. 1 ea. 60-4B Spined Spindle\$2.50 1 ea. 60-42 Clamp Handle75 \$3.25 Yours truly, John Marten Box 125, Richmond, Ind.					
BD3-44	Quill Lock	.20						
41-44	Switch	.95						
50-44	Column Lock	.40						
41-45	Spindle Guard	.95						
50-45	Column Lock Sleeve	.40						
BD3-45	Quill Lock Sleeve	.20						
60-46	Feed Stop Bracket	.95						
BD3A-51	Feed Handle Hub	1.50						
51-52	Feed Handle (4 req.) each	.40						
BD3A-53	Hub Pin	.20						
60-55C	Spring Housing Cap (chrome plated)	.55						
51-56	Feed Handle Ball (4 req.)	.20						
63-64	Pawl Bearing	.45						
63-65	Ratchet Pawl	.40						
63-66	Pinion Shaft Collar	.45						
51-99	Lock Screw	.25						
9-149	Rubber Bushing (not illustrated)	.12						
BD3-102	Grease Cup	.20						
9-214	Connecting Cord No. 18 - 2 Cord 29'	.55						
9-157	Ratchet Pawl Spring (not illustrated)	.12						
9-729	Ratchet Pawl Knob	.20						
*Head Assembly complete		23.75						

All Prices Are Subject to Change Without Notice

NOTICE: This is NOT a packing slip. The parts shown and listed include accessories that are not necessarily part of this tool. NOTE: Standard parts, such as bolts, nuts, washers, etc., are not listed above as such parts can be obtained locally.

*NOTE: On assemblies such as the head assembly, we can supply only the complete assembly at the price shown. We cannot supply assemblies with certain parts for any less money than the complete assembly. This is due to the fact that in the application of modern production methods in our plant, these assemblies are produced on a production line, and may be produced efficiently and inexpensively. Any variation from the standard assembly costs more to make than would be saved by the omission of a few parts.

Printed in U. S. A.