

**CHARACTERISTICS, INSTALLATION AND MAINTENANCE
INSTRUCTIONS WITH PARTS LIST FOR**

**CRAFTSMAN $\frac{1}{2}$ H.P.
Capacitor-Start Electric Motor**

115 Volts, 60 Cycles, 1750 R.P.M.

MODEL NUMBER 115.19780

This is the model number of your Craftsman motor. It will be found on the nameplate attached to the motor. Always mention this model number when communicating with us regarding your motor or when ordering parts.

How To Order Repair Parts

All parts listed herein may be ordered through any Sears retail or mail order store. In ordering parts by mail from the mail order store which serves the territory in which you live, Selling Prices will be furnished on request or parts will be shipped at prevailing prices and you will be billed accordingly.

WHEN ORDERING REPAIR PARTS, ALWAYS GIVE THE FOLLOWING INFORMATION:

1. The Part Number in this List.
2. The Part Name in this List.
3. The Model Number of the motor.

This information is valuable. It will assure your being able to obtain proper parts service. We suggest keeping it with other valuable papers.

SEARS, ROEBUCK AND CO.

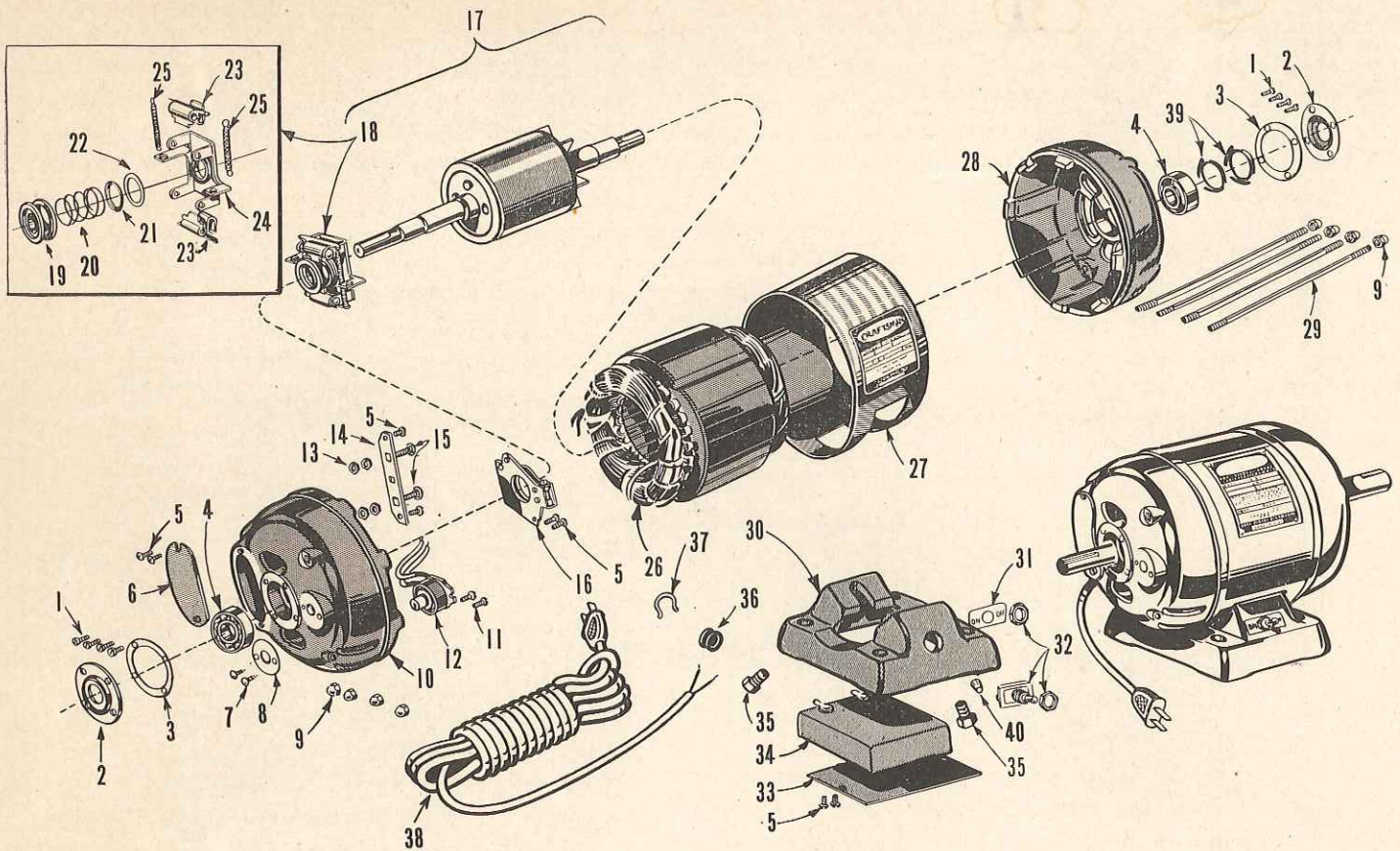

PARTS LIST Model 115.19780

Item	Part No.	DESCRIPTION	Item	Part No.	DESCRIPTION
* 1	5217830	End Cap Screw—#8-32x $\frac{1}{8}$ " Fil. Hd	20	5000214	Governor Spring
2	5220539	Ball Bearing Retainer	21	5215896	Spring Cup
3	5000412	End Cap Gasket	22	5215897	Spring Cup Washer
4	900026	Ball Bearing—New Departure	23	5213107	Governor Finger
* 5	5216591	Machine Screw—#8-32x $\frac{1}{8}$ " Rd.Hd.	24	5220386	Governor Back
6	5217254	Terminal Cover	25	5200990	Governor Side Spring
* 7	145369	Reset Plate Drive Screw—#4x $\frac{1}{8}$ " Rd. Hd.	26	5220525	Stator Assembly
8	5213692	Overload Reset Plate	27	5220535	Band
9	5201073	End Frame Bolt Nut—#10-24 Hex. Crown	28	5220528	End Frame—Opp. Switch End
10	5200531	End Frame—Switch End	29	5220537	End Frame Bolt
* 11	115607	Overload Protector Screws—#8-23x $\frac{1}{8}$ " Rd. Hd.	30	5217598	Base Machined
12	5220532	Overload Protector	31	5213741	Toggle Switch Plate
* 13	5218330	Terminal Post Nut—#8-32 Hex.	32	5214281	Toggle Switch Assembly
14	5216575	Terminal Bar	33	5205003	Condenser Shield
15	5216809	Terminal Post	34	5376825	Condenser
16	5220413	Switch Assembly	35	423351	Base Bolt & Washer Assembly
17	5220521	Rotor Assembly	36	5000254	Grommet—Base
18	5220387	Governor Assembly	37	044617	Cord Strain Relief
19	5215894	Governor Sleeve	38	5217010	Cord Assembly
			39	5201078	Ball Bearing Spring
			40	5217729	Lead Connector

* Standard Hardware Items — May Be Purchased Locally

CHARACTERISTICS, INSTALLATION AND MAINTENANCE INSTRUCTIONS

CHARACTERISTICS

The NAMEPLATE of your motor carries basic information regarding the characteristics that must be taken into consideration if you are to experience the dependable performance and long life that was designed and built into your motor.

POWER RATING

Be certain you are using a motor of the rated horsepower, speed and type recommended by the manufacturer of the unit to be driven.

TYPE

This $\frac{1}{2}$ H.P. Craftsman motor is of the capacitor-start type and is designed to develop a high starting torque. It is particularly suitable for applications such as power tools, compressors, centrifugal and reciprocating pumps, air conditioning units, etc.

POWER SUPPLY REQUIRED

This motor is designed to operate on a power supply with the following characteristics:

1. Volts—115 (at the motor terminals).
2. Cycles or Frequency—60 (which is generally standard in the United States).

If you are not certain of your supply, inquire of your power company.

BEARINGS

Sealed ball bearings make it possible to mount this motor in any position for normal thrust load applications.

SPEED

1750 Revolutions per minute. It cannot be regulated.

ROTATION

This Craftsman motor is designed to drive in either direction. Instruction for changing the direction of rotation are provided on the motor nameplate.

OVERLOAD PROTECTION

A manual reset overload protector is located in the terminal box (switch end) of the motor. It breaks the power supply automatically before the motor overheats sufficiently to damage the windings. The motor **must be allowed to cool** before the overload protector can be reset. To reset, press the red button firmly with the thumb until the protector snaps into running position. Do not tap or strike the reset button.

INSTALLATION

PRE-MOUNTING CHECK

This motor was tested and inspected for electrical and mechanical performance before being packed at the factory, but as a precautionary measure the following steps should be taken before running to make certain it has not been damaged in transit.

1. Rotate the shaft with your fingers. It should turn reasonably free and smoothly.
2. Plug the motor cord into a 115 volt, 60 cycle electrical outlet and move the switch in the "on" position. Operating normally, this motor will have a low electrical hum.

MOUNTING

Mount the motor on the unit for which it was purchased, making certain all pulleys are tightened securely on their shafts and properly aligned. Proper pulley alignment can be obtained by holding a straight edge across the flat sides of the pulley and adjusting to it. The belt tension should be such that the pressure of the fingers on the belt will deflect it readily as shown.

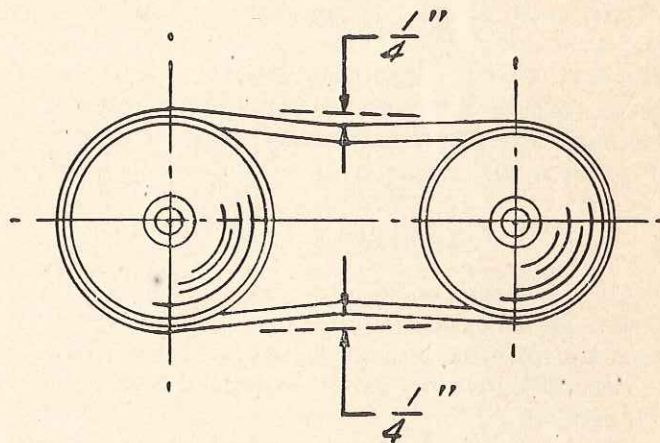

Excessive belt tension increases the motor load and the bearing wear. Loose belts reduce tool efficiency and belt life. Before tightening the mounting bolts, be certain all points of the motor base are in contact with the mounting bracket on the tool or bench. Otherwise, the base may be warped or cracked. Then tighten the motor mounting bolts securely. This motor should be installed in as **cool** and **dry** a place as possible, where it will be protected from excessive deposits of dust and dirt. It should not be confined to the extent that the free flow of air through and about it is restricted.

CIRCUIT

If this motor is not required to start under load and is not overloaded after starting, the standard

15 ampere lighting circuit fuses should be satisfactory. Otherwise, a delayed-action type fuse such as a "fustat" or "fusetron", which is designed to meet the demands of motor protection in addition to the demands of lighting circuit protection should be used.

WIRE SIZE

The following wire sizes are recommended for extensions or special circuits from the source of power supply:

Length of Two-Conductor Extension	Wire Size Required (American Wire Gauge No.)
15 feet or less	No. 14
50 feet or less	No. 12
100 feet or less	No. 10

GROUNDING

As a precaution against the possibility of electrical shock from a ground in the motor or a static electrical charge built up in the driven unit, which is common with belt driven equipment, both units should be grounded. If the two units have metal to metal contact, grounding of either one will be sufficient protection for both. This can be accomplished by running a wire from the frame to a water pipe, steam pipe, or any other metal object making direct contact with the earth. Good electrical contact can be established between the metal surfaces and ground lead by removing all paint and other foreign material from the surface of the metal at the point of connection.

MAINTENANCE

Installed as instructed, this motor should give trouble-free service when properly lubricated, kept clean and supplied with power of the same rating as described on the motor nameplate. Usually 115 volt, 60 cycle).

LUBRICATION

The ball bearings in this motor were pre-lubricated at the factory for a minimum of 5,000 hours operation. Should they require repacking, clean thoroughly with gasoline, dry and repack. The proper grease is a non-hardening grease made for ball bearing lubrication. Do not fill more than 25% of the free air space. Over-packing causes

bearings to overheat besides increasing the motor load. Do not oil ball bearings.

CLEANING

Make every effort to prevent foreign materials from entering the motor. Beyond that, visually inspect it periodically. Usually, normal accumulations of dry dust can be blown out successfully. Motors used on wood working tools, especially, should be vacuumed or blown out often to clear accumulations of saw dust that prevent proper motor ventilation and which may clog the centrifugal starting switch.

Should disassembly be necessary, refer to competent service personnel as recommended under SERVICE, since disassembly by others voids the guarantee of the manufacturer.

LOW VOLTAGE

Approximately 90% of all motor failures are the result of low voltage at the motor terminals or serious motor overloading. Although your motor is designed for operation on the voltage and frequency specified on the motor nameplate, normal loads can be handled safely on voltages that are not more than 10% above or below the rated voltage. However, heavy loads require the specified voltage at the motor terminals.

Some Cause of Low Voltage are:

1. Overloaded circuits
2. Under-sized wires
3. Overloading of power company's facilities

Some Effects of Low Voltage are:

1. Motor doesn't develop full power
2. Motor starts slowly
3. Motor overheats
4. Fuse or circuit breaker opens frequently

SERVICE

Only qualified persons who have the proper tools and equipment should attempt to service this motor. The Guarantee covering it is void if either end frames (Item 10 or 28) has been removed by anyone other than an Authorized Sears Service Station. External parts such as the cord (Item 38), Base (Item 30), Terminal Cover (Item 6), and Stator Cover Band (Item 27) may be removed without voiding the Guarantee. The nearest Sears retail or mail order store will have your motor serviced for you promptly at a reasonable rate.

GUARANTEE

This CRAFTSMAN motor was thoroughly inspected and tested before shipment. Should it fail due to faulty material or workmanship, we will repair it free of charge if returned to your Sears retail or mail order store within one year from date of purchase. This guarantee is void if the motor has been misused, abused or disassembled.

SEARS, ROEBUCK AND CO.