

**OPERATING INSTRUCTIONS
AND PARTS LIST FOR**

**CRAFTSMAN
DRILL PRESS**

Model Number 103.23130

This is the model number of your Drill Press. It will be found on a plate located on the base near the column. Always mention this model number when communicating with us regarding your Drill Press, or when ordering parts.

Instructions for Ordering Parts

All parts must be ordered through a Sears' retail or mail order store. Parts are shipped prepaid. When ordering repair parts, always give the following information:

1. The part number
2. The part name and price
3. The model number 103.23130

This list is valuable. It will assure your being able to obtain proper parts service. We suggest you keep it with other valuable papers.

SEARS, ROEBUCK and CO.

October, 1946

OPERATING INSTRUCTIONS AND PARTS LIST FOR CRAFTSMAN DRILL PRESS

MODEL NUMBER 103.23130

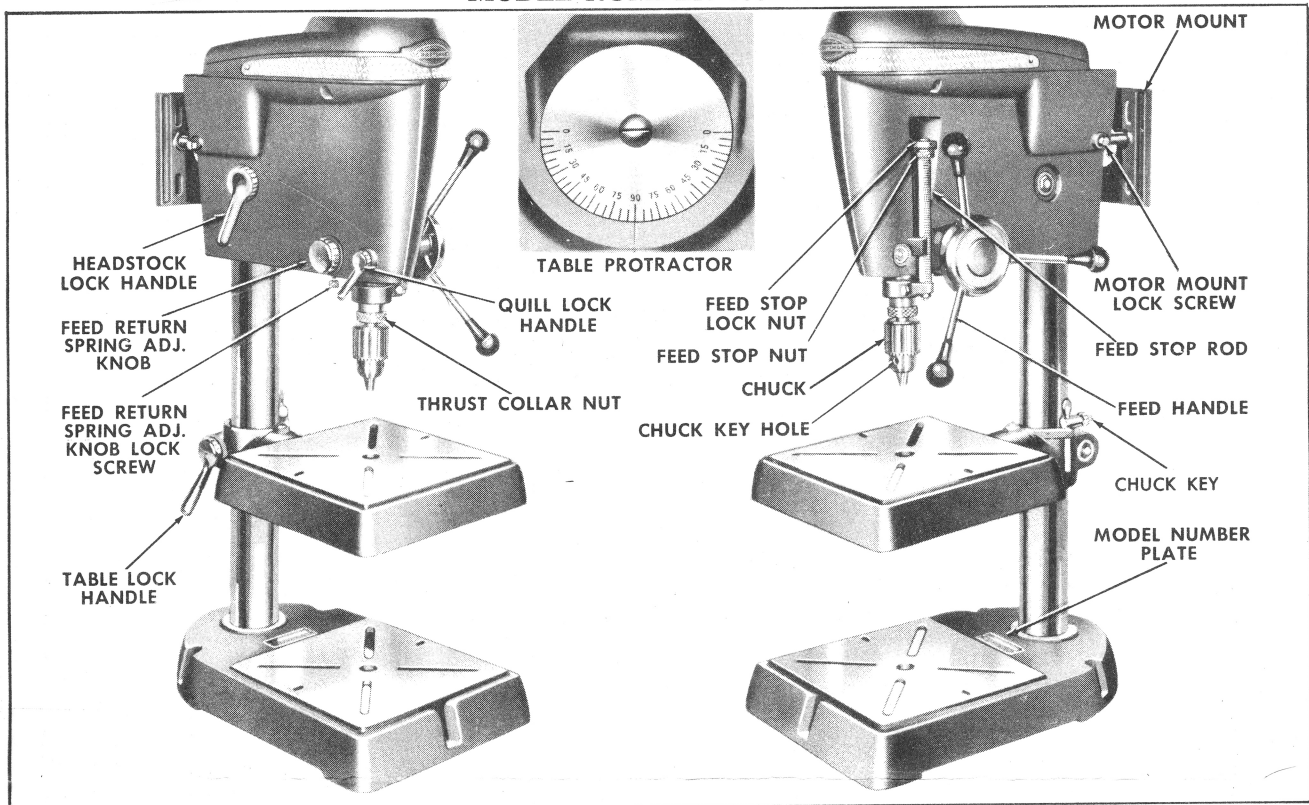

FIGURE 1

REASSEMBLING:

This Drill Press has been completely inspected and tested at the factory. To avoid loss of parts during shipment, the following parts have been packed separately in an enclosed carton: the belt X-1459, the motor pulley 18026, the motor pulley Allen wrench X-1400, the chuck 18130, the chuck key 18129, and the chuck release wedge 18131.

The chuck may be installed by placing it on the tapered portion of the spindle and tapping lightly on the bottom of the chuck with a block of wood to insure proper seating of the tapers on the spindle and in the chuck. Be sure that the taper in the chuck and on the spindle are clean. A hole is provided in the table support in which the chuck key may be kept as shown in Figure 1. The chuck release wedge should be kept in a handy place near the drill press so that it will not be lost.

INSTALLATION:

For proper operation under normal load, this drill press should be driven by a $\frac{1}{3}$ horsepower 1750 R.P.M. ball bearing motor. If the drill press is to be used for heavy duty work, a $\frac{1}{2}$ horsepower motor is recommended.

To install this motor, back out the motor mount lock screws (Figure 1) until the motor mount may be removed. Fasten the motor to the mount with the bolts, washers and nuts packed in the enclosed carton. Place a washer X-601 under the head of each bolt X-322, and under each nut X-417. The motor pulley, which has a $\frac{1}{2}$ inch bore, should be installed on the shaft of the motor with the small step of the pulley

toward the motor. Tighten the pulley set screws securely. *The direction of rotation of the spindle must be clockwise.* Replace the mount in its normal position as shown in Figure 1. For normal operation, the large step on the motor pulley should be in line with the small step of the spindle pulley. Place the belt around one of the steps on the spindle pulley and around the aligned step of the motor pulley. Tighten the belt by pulling the motor mount away from the drill head. When the belt is tight, tighten the two motor mount lock screws securely.

The Drill Press should be bolted securely to a well constructed work stand or table before operation. Three $\frac{13}{32}$ inch holes are provided in the base for this purpose.

LUBRICATION:

The four ball bearings on this Drill Press were carefully packed with lubricant at the factory, and will require no further attention for the life of the bearing. Three oil holes have been provided for occasional application of light machine oil to other moving and sliding parts. These oil holes are located as follows: one may be found on the left side of the headstock casting 27215 in line with the spindle and approximately 6 inches from the top of the casting; another is located on the right side of the drill press directly over the pinion shaft 27616, near the feed handle hub; the third is in the spindle pulley on the top face of the second step from the top. Oil may also be applied to the splines of the spindle at the top of the pulley. Care should be exercised to keep oil off the belt.

SPEED:

When the pulleys are in the same plane there are four speeds available. With a 1750 R.P.M. motor, the spindle will rotate at approximately 5000 R.P.M. when the largest step on the motor pulley and the smallest step on the spindle pulley are used. When using the next step down on each pulley, the resulting speed will be approximately 2450 R.P.M. A speed of approximately 1250 R.P.M. can be attained by moving the belt to the third step from the top on each pulley. The lowest speed available, 625 R.P.M., may be obtained by placing the belt on the smallest step of the motor pulley and the largest step of the spindle pulley.

Other speeds are attainable by changing the position of the motor pulley in relation to the spindle pulley so that further step combinations are created.

Due to variation in the bit pattern, the type, hardness, and grain of the material, and the depth and quality of the hole desired, it is impractical to attempt to establish a fixed table of drill feeds and speeds for boring in wood. It is best to follow this general rule: the larger the hole, and the harder the material, the slower the feed and speed. An approved method is to start any drilling operation with a moderate feed and speed, increasing either or both after noting the effect on the drill.

In wood drilling operations, drills up to $\frac{3}{4}$ inch in diameter may generally be run at 1800 to 3000 R.P.M. without burning, while bits $\frac{3}{4}$ inch in diameter or over cannot generally be run over 2400 R.P.M. without burning. Multi-spur bits, expansive bits, and hole saws should never be operated over 750 R.P.M. In general, if the drill smokes in the hole, reduce the feed and speed to prevent burning.

When drilling metal, if it is noted that the drill wears away at the extreme outer corners of the cutting edges, it is an indication of too much speed. Likewise if the drill chips on the cutting edge, it is an indication of too heavy a feed. Very small drills are generally designed for high speed and light feed and should be used accordingly for best results.

Always reduce the feed pressure when the drill is breaking through the surface of a work piece. This reduces the tendency of the drill to bite deeply at this point and thereby minimizes drill breakage.

CHUCK:

The jaws of the chuck may be adjusted to hold drills up to $\frac{1}{2}$ inch shank diameter by using the key 18129 provided. The key should be inserted in one of the holes in the chuck shank so that the teeth of the key and of the chuck mesh. In this manner the jaws may be opened by turning the key counterclockwise and closed by turning the key clockwise.

CONTROLS:

The chuck may be lowered approximately $4\frac{1}{2}$ inches by turning the pinion shaft counterclockwise. For this purpose the feed levers or feed handles (Figure 1) are provided. The feed mechanism incorporates an automatic spring loaded return action.

The feed stop nut (Figure 1) may be used when two or more holes must be drilled to the same depth, or when the depth of a blind hole must be set before drilling. The feed stop lock nut acts, as its name indicates, to lock the feed stop nut in position to prevent its shifting due to machine vibration.

When performing operations such as shaping, flut-

ing, and surface grinding, it is necessary that the vertical position of the chuck remain fixed. For this purpose, the quill lock handle is provided. When tightened in a clockwise direction this handle causes the quill 27614 to be held firmly in one position.

For drilling on an angle the table may be tilted by removing the pin 27612 and loosening the table tilt clamp bolt located under the table near the column. When the table is tilted to the desired angle as shown on the protractor under the table, the clamp bolt should be securely tightened. It should be noted at this point that as the work piece is rotated on the tilted table, the axis of the drilled hole will change in relation to the axis of the work piece, thereby changing the point at which the drill will emerge if the piece is drilled through. A trial hole drilled in a scrap piece is often a good check on an operation of this type. After returning the table to an approximate level position, it may be leveled accurately by tapping the tapered pin firmly in place.

The table may be raised or lowered on the column to accommodate a thick work piece or a long drill by turning the table lock handle counterclockwise until the table moves freely. During this operation the table should be firmly supported to prevent its dropping quickly which might result in injury to the operator or breakage of parts.

The headstock lock handle functions in the same way as the table lock handle; however more care must be exercised when releasing the headstock lock handle due to the much greater weight of the parts supported.

ADJUSTMENTS:

For most satisfactory results, the vee belt (X-1459) should be kept tight. Slippage of the belt under normal conditions is good indication that it should be tightened. If the automatic feed return fails to bring the chuck back to the top of the stroke, or if the return action is sluggish, the tension may be increased as follows: lock the chuck at the top of its stroke by using the quill lock handle. Back out the feed return spring adjusting knob lock screw and turn the feed return spring adjusting knob counterclockwise several turns to build up spring tension. Loosen the quill lock and run the chuck down with the feed handle. If the tension is still not sufficient, it may be further increased by repeating the above adjustment. If when the table is leveled, and the tapered pin is inserted fully, the protractor does not show a 90° setting, the following adjustment may be made. The screw (X-517) may be loosened and the protractor turned until the 90° mark on the protractor lines up with the scribe mark as shown in Figure 1.

If the headstock lock handle should strike the head casting before locking, or if it blocks accessibility to the motor mount lock screw, or if the quill lock handle should block accessibility to the feed return adjusting knob, the handle positions may be changed without disturbing their locking efficiency. By backing out the small slotted head set screws in the respective lock handles, the handles may be removed from the heads of the hexagon screws on which they are engaged and rotated until their locked position no longer causes interference. Reinstall the handle on the hexagon head of the screw and tighten its set screw. In the same manner, the table lock handle may be removed from its normal position and used on the hexagon head of the table tilt lock (X-278).

TYPES OF BITS:

A variety of bits is available for use in your drill press. The solid center wood bit has a single flute turning around a solid center, but carries two spurs and two cutting edges.

The hollow spiral bit or ship auger is an excellent bit for drilling deep holes in wood. Its design permits very efficient removal of chips, necessary in deep hole drilling. The hollow spiral bit has but one cutting edge.

The fluted bit is an excellent all around wood boring tool. It has two flutes or twists, each terminating in a cutting edge and spur.

Perhaps the best bit for high quality machine drilling in wood is the spur machine bit in a twist drill pattern. It is a stiffer drill than any previously described, tracks nicely, and cuts an exceptionally smooth hole.

The twist drill while almost universally used for metal drilling with a 120° included angle between the cutting lips is readily adapted to wood drilling by changing the angle to approximately 70°.

For larger holes, the multi-spur or rim type bit is often used. This type bit generally has a single cutting edge with several spurs arranged as saw teeth around the rim. The expansive bit is a handy drilling tool for large holes due to the variety of hole sizes which may be drilled without having to stock separate drills of large diameters not often used.

When the expansive bit, as well as any of the previously described bits are used on the drill press, the screw point should be altered to a brad point by removing the threads. This will not impair the efficiency of the bit and will prevent the coarse screw threads from engaging the wood and raising it from the table.

For use on the drill press the double lip style countersink is more desirable than the rosette type. The double lip style will make a cleaner cut and will tend to remain more clear of chips and gum under continuous operation.

While high speed steel drills generally give more satisfactory service for commercial operation because of higher speeds possible, and because they hold their edge longer, their greater cost often makes their use in the home shop unwarranted. Unless extensive metal drilling operations are

planned, the less expensive carbon steel drills will give quite satisfactory results.

DRILL SHARPENING:

When grinding drills, in order to maintain the efficiency of the drill, extreme care should be exercised. The dead center or point of the drill must be maintained, that is, the cutting lips must be of equal length. (See Figure 2.) Also their angle must be the same in relation to the axis of the drill (approximately 60° each or 120° included angle between the cutting lips for metal, 35° each or 70° included for wood). The metal should be relieved gradually behind the cutting edge so that the included angle at the heel of the cutting lips will be approximately 12° on a side less than at the cutting edge itself.

OPERATION:

When the drill press is used for wood working it is advisable to fasten a smooth level auxiliary table of $\frac{3}{4}$ inch plywood to the metal table using countersunk flat head screws or bolts. This auxiliary table not only increases the working surface available, but provides a surface on which auxiliary fences, shaping guides, pivot pins and other similar units may easily be used. This auxiliary table also will minimize the danger of drilling through the work piece into the metal table.

If the drill is to pass completely through the work piece it is advisable to place a piece of scrap wood under the work piece at the point of breaking through to prevent splintering and mutilation of the lower surface as the bit breaks through.

Another method of preserving the surface at drill break through is to reverse the wood and drill through from the opposite side as soon as the drill point emerges on the lower surface.

When boring to a definite depth in a blind hole the feed stop nut may be set to the desired depth limits by lowering the drill to a mark on the edge of the work piece corresponding to the hole depth desired. When drilling to an approximate depth the graduated scale on the feed stop rod may be used.

A straight piece clamped to the table as a guide or fence has many uses, as in drilling several holes equidistant from a common edge or as a guide in grooving or fluting operations.

The work piece should be held securely on the table either by clamps or pins to prevent its turning with the drill. A drill vise is an inexpensive and very handy unit, designed to hold various odd shaped work pieces for drilling. Cylindrical work pieces such as dowels, or turned work pieces of various diameters present difficulties when an attempt is made to drill through or into their centers without an adequate stabilizing device. The drill vise or a V block should always be used for work of this type.

When it is necessary to drill into the edge of a circular flat piece, rather than attempting to set the piece on edge which offers problems of hole location, and of maintaining stability, it is often more desirable to clamp the piece flat to the table surface and to turn the table so its surface is parallel with the drill. In this manner the work is stable and the angle fixed.

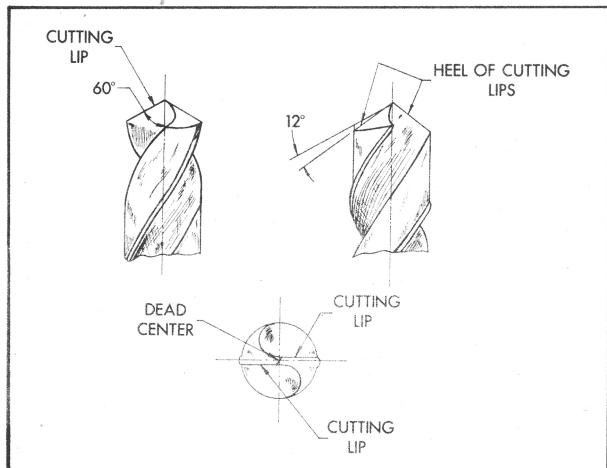

FIGURE 2

If the drill is long enough to go through the piece, but its penetration is limited by the travel or feed limit of the chuck, the piece may be set up on a block after the first cut of maximum feed depth has been made, thus allowing the drill to penetrate to its maximum length.

Holes through a piece, the thickness of which is greater than the drill length, may often be completed by first establishing the location of the piece in relation to the drill center, then after drilling as far as possible from one side the piece may be reversed and the hole completed from the other side.

All metal work should be clamped securely to the work table before drilling is attempted. Should the drill lodge in a piece not clamped, it could easily tear the piece from the operator's grip resulting in injury to the operator as well as mutilation of the drill press and work piece. A punch mark on the metal surface at the center of the proposed hole will tend to keep the drill on center until the drillspot is established.

Avoid set-ups which will allow the work to spring. This will help minimize drill breakage.

Lubricants should be used on all metals except cast iron which is drilled dry. For most metals, lard oil is a suitable lubricant; for the harder metals a solution of sal soda in water may be used.

This drill press is designed to give maximum protection from moving parts at all times. Since a guard on the chuck and drill would also hide the work, it must be impressed upon the operator that as with all rotating power tools, no loose clothing should be worn when working with the drill press. The face should be kept away from the drill so that the hair does not become entangled with moving parts or that flying chips do not injure the operator.

Accessories will be listed in the catalog with

which further operations may be performed on your drill press such as dovetailing, mortising, shaping, routing, carving, sanding, spot finish, or engine turn, cutting of plugs or dowels, fluting and reeding and buffing. An interesting booklet covering details on these various operations is available at your Sears' retail or mail order store.

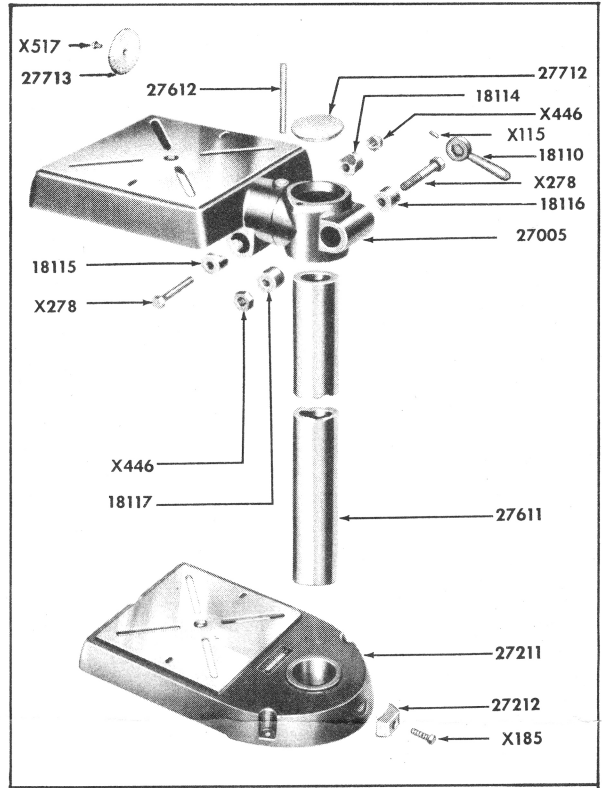

BASE TABLE AND ASSOCIATED PARTS

PARTS LIST

Part No.	Part Name	Prepaid Selling Price Each
BASE, TABLE AND ASSOCIATED PARTS		
18110	Lock Handle	\$ 1.20
18114	Table Tilt Lock	.35
18115	Table Tilt Lock Sleeve	.35
18116	Table Support Lock	.35
18117	Table Support Lock Sleeve	.35
27005	Table & Support Assembly	18.50
27212	Base Lock Shoe	.35
27211	Base	14.50
27612	Taper Pin	.25
27611	Column	8.00
27712	Column Plug	.30
27713	Scale	.35
HEAD FRAME AND ASSOCIATED PARTS		
18026	Motor Pulley	2.00
18110	Lock Handle	1.20
18118	Headstock Lock Sleeve	.45
18119	Headstock Lock	.45
18120	Quill Lock Handle	.80
18121	Quill Lock	.30
18122	Quill Lock Sleeve	.30
18129	Chuck Key (Jacobs No. 3)	.80
18130	Chuck & Key (Jacobs No. 6A-33)	11.00
18131	Chuck Release Wedge	.20
18211	Quill Ball Bearing	1.75
18212	Pulley Ball Bearing	2.15
18410	Spindle Collar	.50
18413	Spindle Pulley Sleeve	.25
18414	Snap Ring (Small)	.10
18415	Snap Ring (Large)	.15
18416	Feed Stop Bracket	1.00
18417	Quill Gasket	.10
18421	Washer	.10
18422	Washer	.10
18425	Feed Stop Lock Nut	.35
18426	Feed Stop Spacer	.10
18427	Feed Stop Nut	.30
18428	Thrust Collar Nut	.35
18429	Rubber Washer	.10

Part No.	Part Name	Prepaid Selling Price Each
18511	Knob Lock Screw	.15
18512	Quill Lock Screw	.15
18513	Pinion Shaft Retaining Screw	.15
18614	Feed Return Adj. Knob	.85
18915	Feed Return Spring	.25
18916	Feed Handle Knob	.40
18920	Motor Mount	2.15
27130	Spindle Assembly	4.00
27160	Hub, Pinion, Spring, & Pin Assy.	4.25
27215	Drill Head Frame	26.00
27415	Spindle Pulley	4.75
27614	Quill	4.00
27615	Feed Stop Rod	2.60
27617	Pin	.15
27618	Feed Handle Rod	.60
27714	Panel	.80

THE FOLLOWING PARTS ARE STANDARD AND MAY BE PURCHASED LOCALLY

X-109	Slotted Hd. Set Screw No. 10-24 x 1/4-Cup Point	.10
X-115	Slotted Hd. Set Screw No. 10-24 x 3/8-Cup Point	.10
X-135	Socket Hd. Set Screw 5/16-18 x 5/8-Cup Point	.10
X-170	Socket Hd. Set Screw 5/16-18 x 1/2-Cone Point	.10
X-185	Square Hd. Set Screw 1/2-13 x 1-1/4-Cup Point	.10
X-205	Hex Head Cap Screw 5/16-18 x 3/4	.10
X-277	Hex Head Cap Screw 1/4-20 x 1-1/2	.10
X-278	Hex Head Cap Screw 1/2-13 x 3	.10
X-280	Hex Head Cap Screw 1/2-13 x 4	.10
X-322	Sq. Hd. Mach. Bolt 5/16-18 x 2	.10
X-413	Hex Nut 3/8-16	.10
X-417	Semi-Finished Am. Std. Reg. Full Hex Nut 5/16-18	.10
X-420	Hex Nut 1/4-20	.10
X-446	Hex Nut 1/2-13	.10
X-517	Round Hd. Mach. Screw 1/4-20 x 3/8	.10
X-565	Round Hd. Mach. Screw No. 8-32 x 3/4	.10
X-601	Plain Washer 11/32	.10
X-1400	Allen Wrench 5/32	.15
X-1459	Stand V-belt 1/2 x 44	1.60
X-2951	Self Tapping Screw No. 6-32 x 1/4	.10

This sheet is intended for instruction and repair parts only and is not a packing slip. The parts shown and listed may include accessories not necessarily part of this tool. All parts are shipped prepaid. All prices are subject to change without notice.

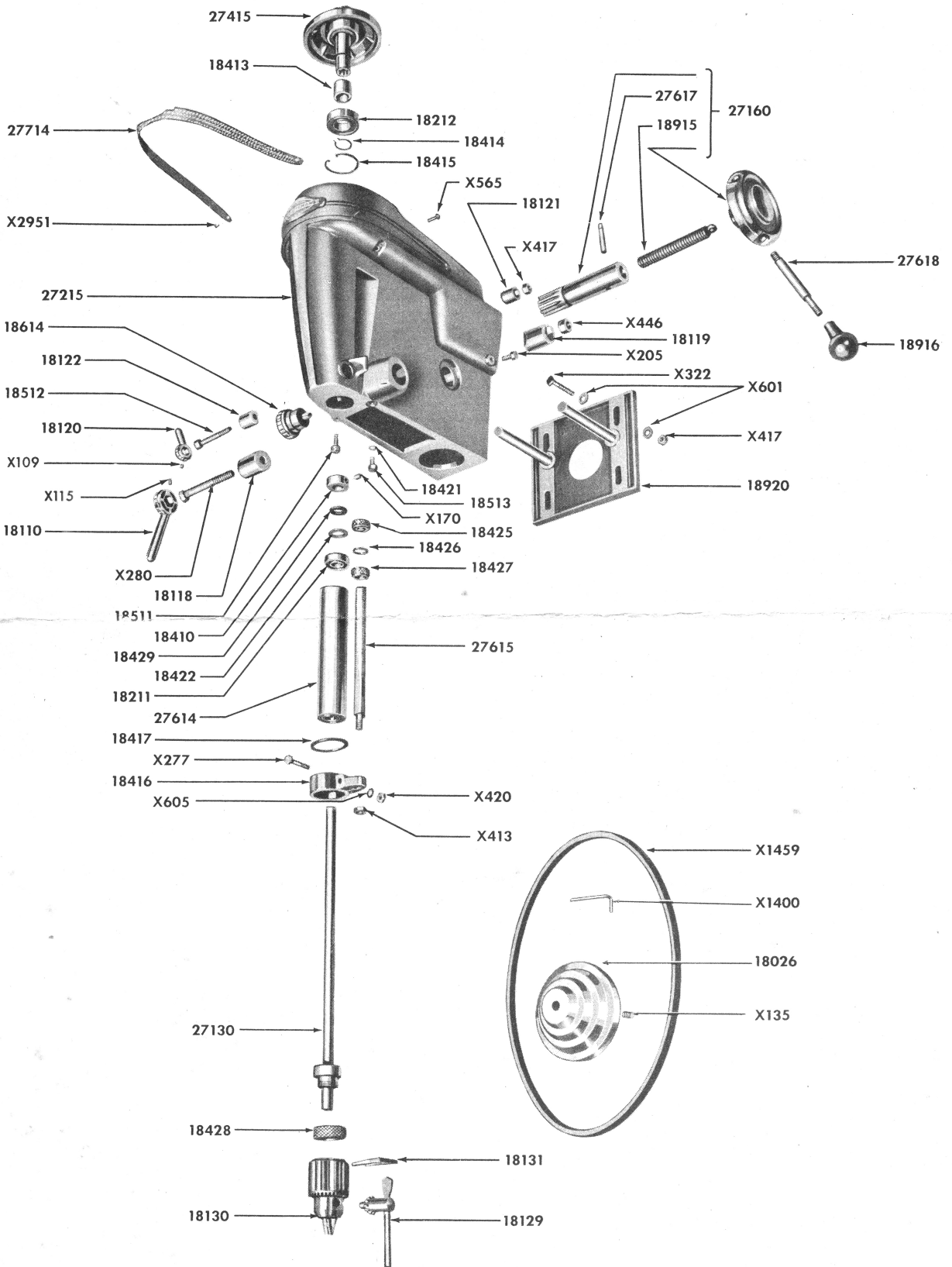

HEAD FRAME AND ASSOCIATED PARTS