

FEB 23 1955

INSTRUCTIONS FOR ASSEMBLY OF  
PEDESTAL TYPE  
**TOOL STAND 99-2960**

FOR JOINTER - CAT. NO. 2390



**SEARS, ROEBUCK and CO.**

LITHOGRAPHED IN U. S. A.

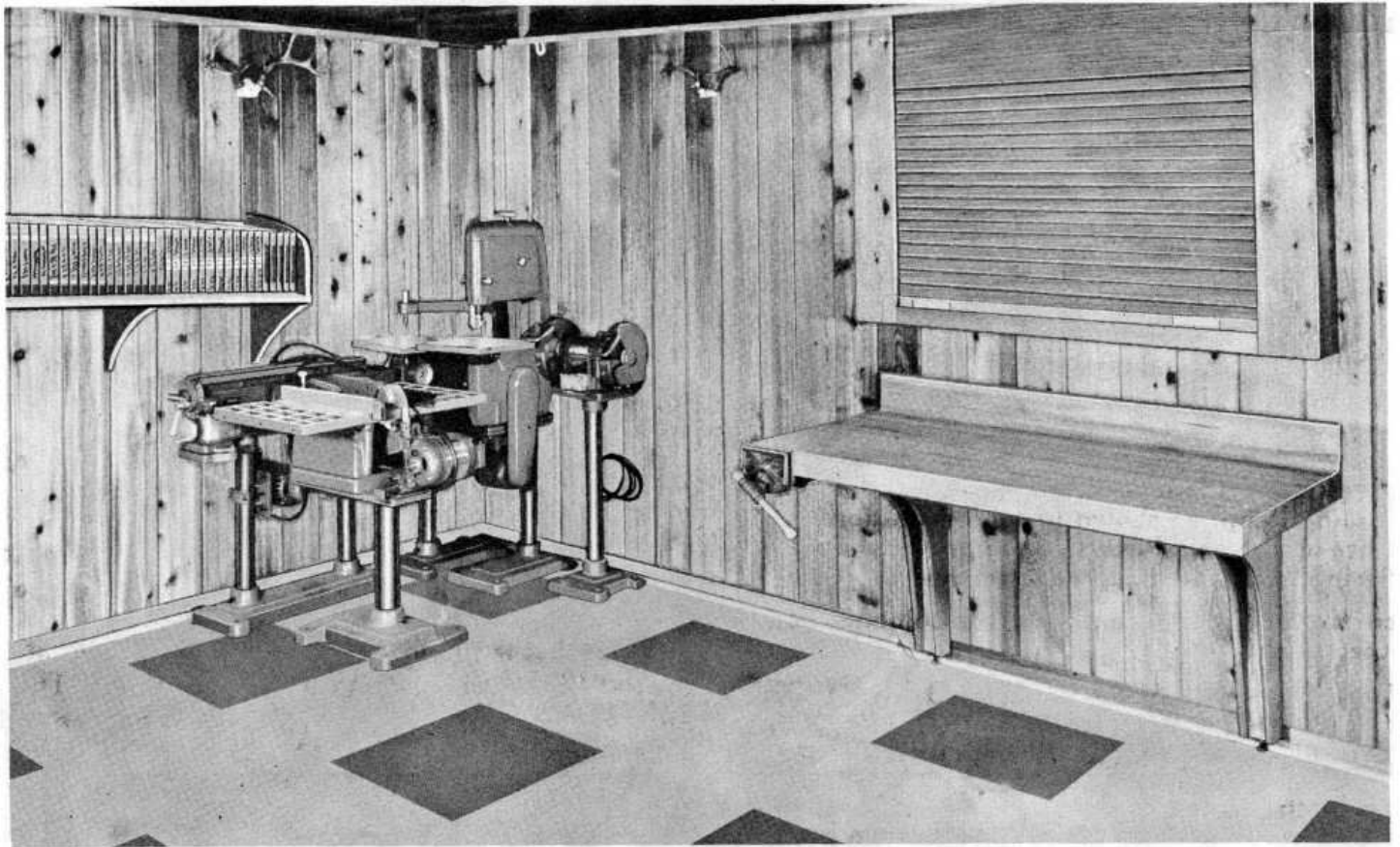
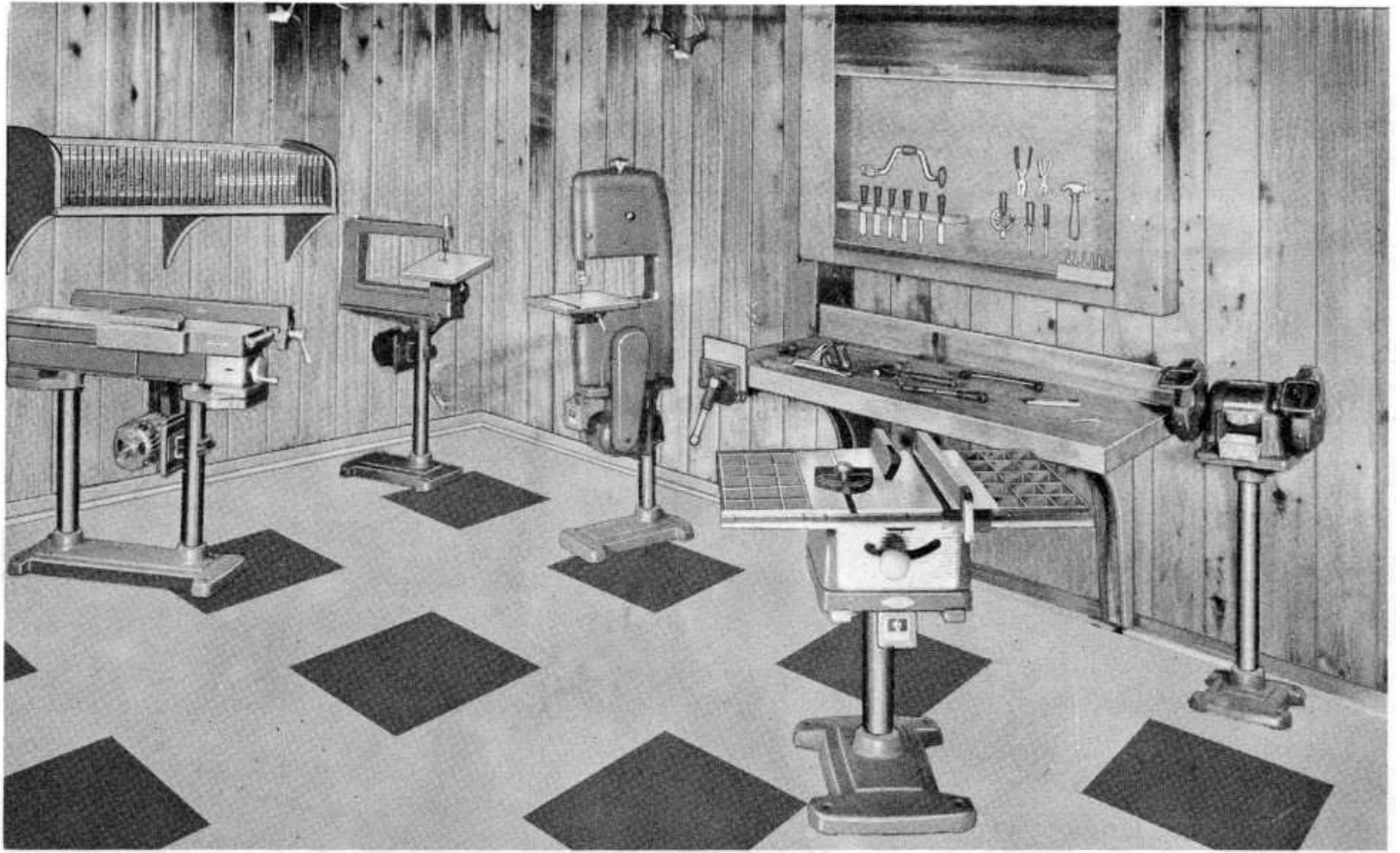

**Through the use of Casters, which may be purchased under Cat. No. 2819, you can better utilize your Workshop Area.**

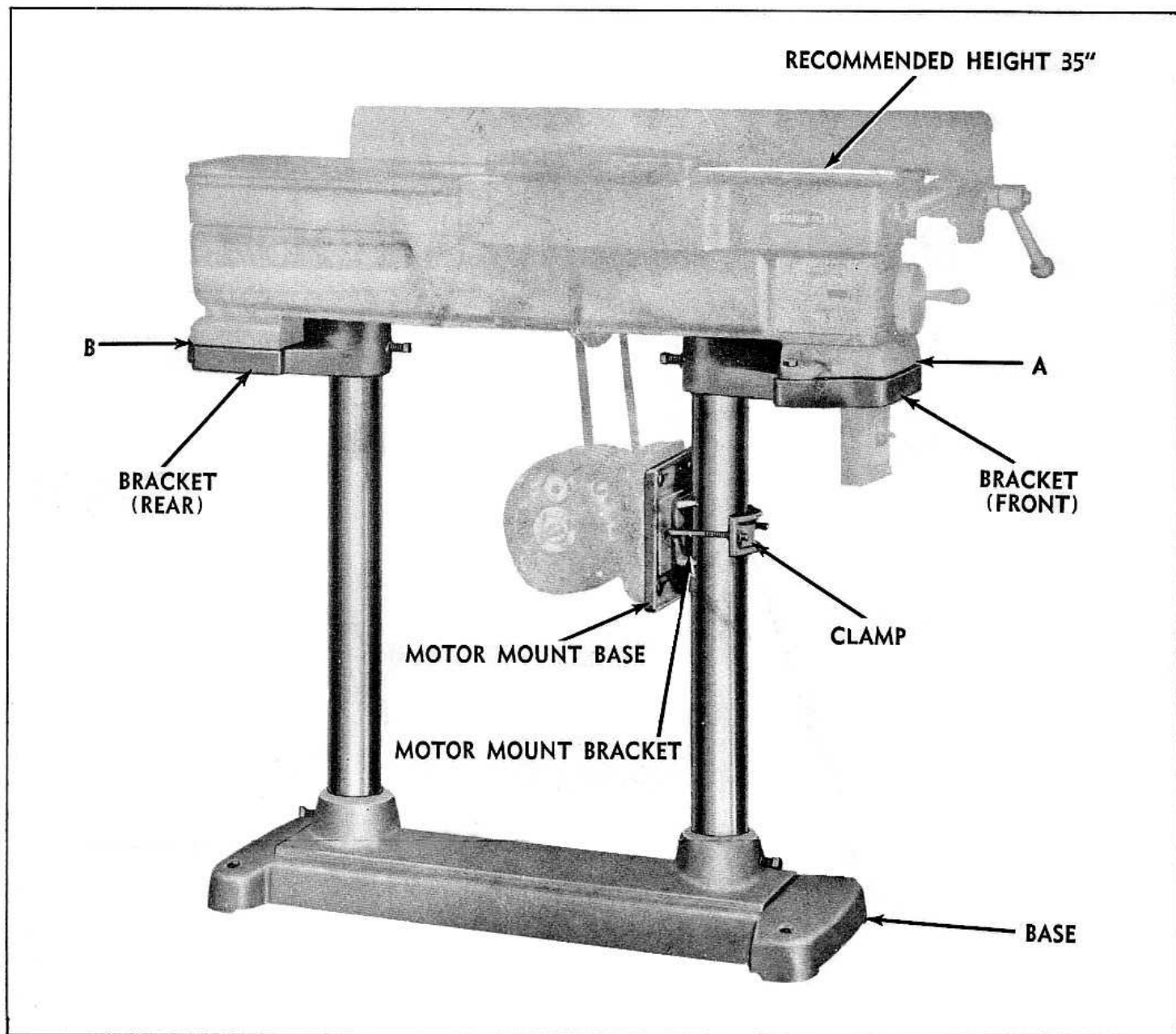

### ASSEMBLY INSTRUCTIONS

Assemble the two columns into the base casting and tighten the two square head set screws securely. Attach your motor to the motor mount base with the four 5/16-18 x 2 inch square head bolts and the nuts and washers provided. Position the motor mount bracket and clamp, as shown in the illustration and slide entire unit over column to an approximate position. Secure lightly for final adjustments.

Place front and rear brackets on columns and tighten set screws.

**CAUTION: SURFACES A AND B MUST BE HELD TO A UNIFORM HEIGHT FROM FLOOR TO PERMIT PROPER MOUNTING OF JOINTER.**

Fasten your jointer to the assembled tool stand, using the three 5/16-18 x 1 1/4 inch square head bolts, and the nuts and washers provided.

Final adjustments can now be made for belt instal-

1. Shift motor on motor base until the two pulleys are in the same plane.
2. Adjust entire motor mount assembly up or down on column for proper tensioning of belt.

A bracket is supplied which will permit mounting the POWR PANL, Cat. No. 2120 on the tool. This is an "L" shaped bracket. One side is wider than the other which will allow various means of mounting the POWR PANL to the tool. Mount the switch to best suit your needs. The illustration showing the mounting position is a suggested method only.

### AVAILABLE ACCESSORIES

PURCHASE FROM YOUR NEAREST SEARS RETAIL STORE OR MAIL ORDER HOUSE.

- SET OF 4 CASTERS — CAT. NO. 2819 — FOR READY MOBILITY**
- BELT GUARD — CAT. NO. 2908-37" BELT LENGTH REQUIRED WHEN GUARD IS USED**
- POWR PANL — CAT. NO. 2120 — FOR SAFE HOOK-UP**

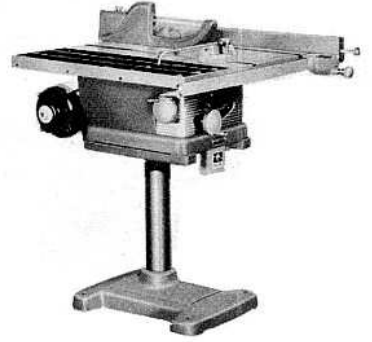
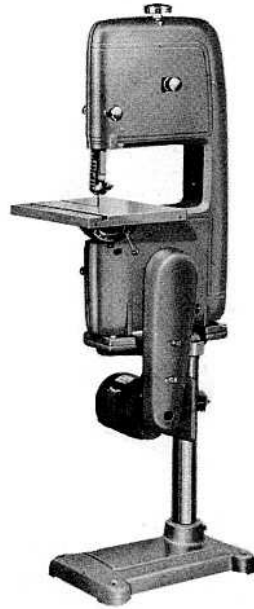

**PURCHASE THESE TOOL STANDS  
FROM YOUR NEAREST SEARS  
RETAIL STORE OR MAIL ORDER  
HOUSE.**

