

The newest
member of the
CRAFTSMAN
family of
fine saws for
1960-61

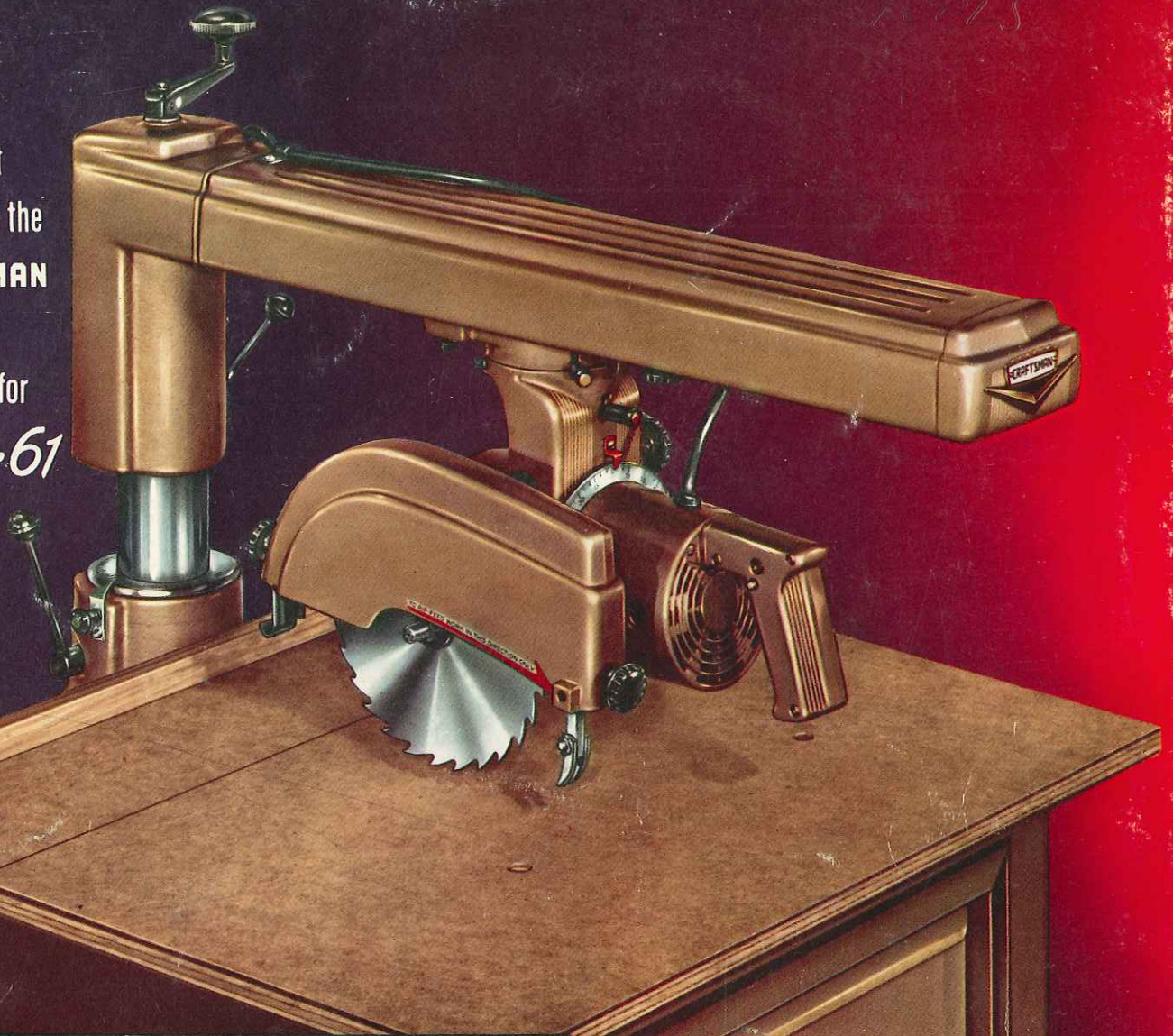

SEARS



REG. U. S. PAT. OFF.

**POWER
TOOLS**

Sears, Roebuck and Co.

Satisfaction Guaranteed or Your Money Back

New! We believe it's America's lowest priced quality-built Radial-Arm Saw

(Illustrated on the front cover)

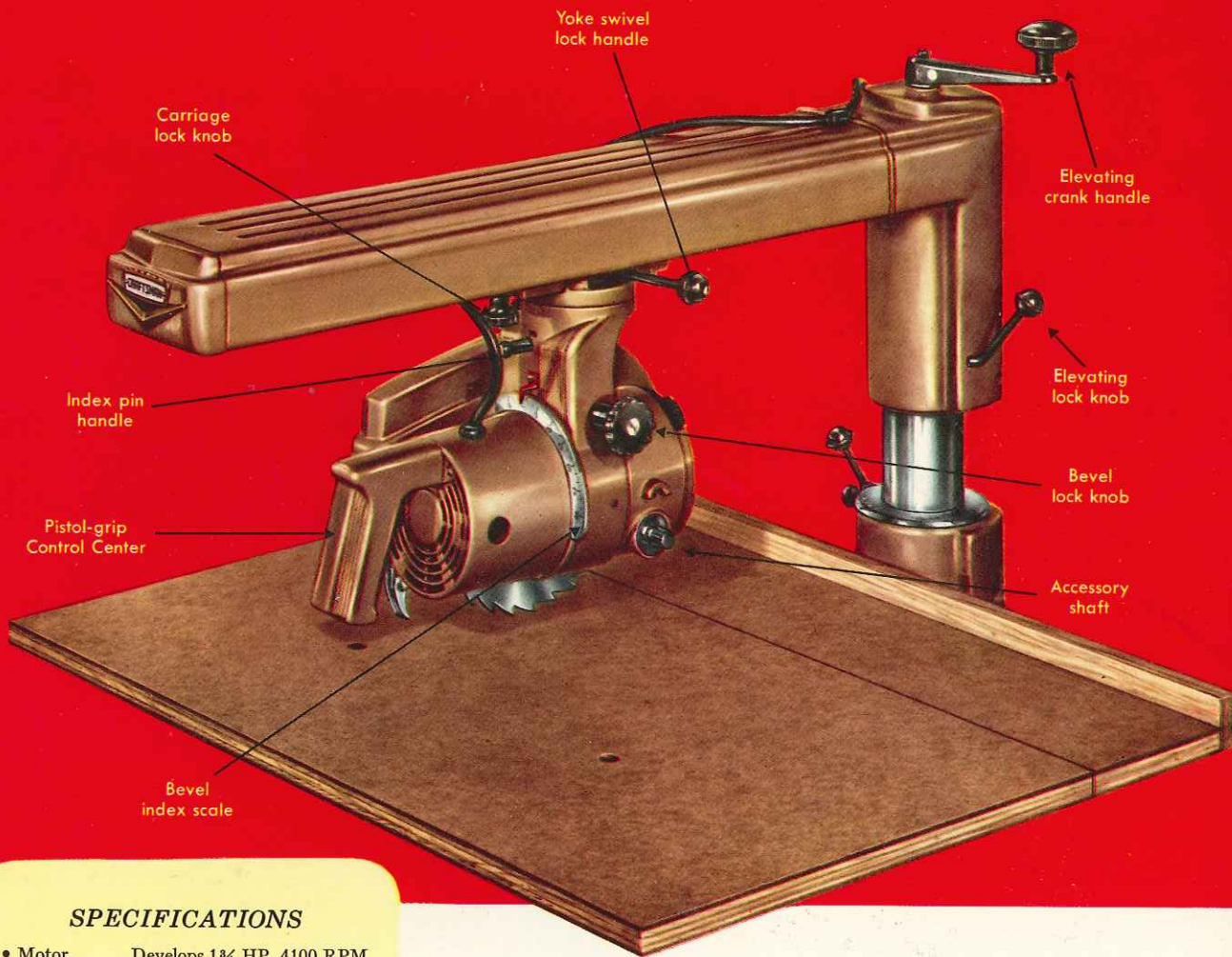

SPECIFICATIONS

- Motor Develops 1 $\frac{3}{4}$ HP, 4100 RPM
- Blade size 9-in. x $\frac{1}{2}$ -in. center hole
- Depth of cut (maximum) 3 $\frac{1}{8}$ in.
- Depth of cut 45° (maximum) 2 $\frac{3}{8}$ in.
- Width of crosscut maximum in 1-in. stock 15-in. with table fixed 21-in. by moving table
- Width of rip (maximum) 26 $\frac{1}{8}$ in.
- Height adjustment 6 $\frac{1}{2}$ in.
- Dado size 6-in. diameter x $\frac{1}{16}$
- Dado depth (maximum) 1 $\frac{5}{8}$ in.
- Miter index stops Arm rotates 360° fixed stops at 0° and 45° left or right
- Yoke Swivels 360° with fixed stops at 0° and 90° left or right
- Bevel index Motor tilts 180° fixed stops 0°, 45° and 90° left and 90° right
- Scales Miter and bevel
- Table Adjustable 23 $\frac{1}{2}$ x31 $\frac{3}{4}$ -in. laminated hardboard and plywood
- Column diameter 2 $\frac{3}{4}$ in.
- Distance from center line of column to end of arm 31 $\frac{3}{4}$ in.
- Overall height (column extended) 26 $\frac{1}{4}$ in.
- Switch Trigger switch with key lock

CRAFTSMAN 9-in. Saw develops 1 $\frac{3}{4}$ HP
REG. U.S. PAT. OFF. makes precision cuts quickly!

\$199⁰⁰ Only \$5 down
cash

Fast, finger-tip action Pistol-grip Control-center Handle . . . *no other* saw commands so many functions from a single point:

Controls these operations: 1. Feeds Saw 2. Swivels 3. Bevels 4. Rotates

Contains these switches: 1. Key-operated main power switch (provides added safety because only your key can turn it on). 2. Instant-action trigger switch for stop-start cutting. 3. Button switch locks saw into permanent "on" position.

Because greater control and internal rigidity mean better cutting accuracy, we made the yoke an integral part of the motor housing to provide rock-solid stability . . . a band of steel clasps housing firmly.

Makes *any* cut you want . . . 4-way positioning places blade in any conceivable position. Motor carriage glides along length of arm . . . unique flotation on 8 lubricated-for-

life, multi-ball bearing races. Tensioning device controls pressure required to move carriage. Color-coded controls for instant identification . . . adjust quickly, easily. Anti-kickback and hold-down built into fixed blade guard.

Auxiliary motor shaft allows use of all standard shanked tools, bits, etc. 728 sq.-in. warp-resistant laminated table adjusts to add 6 in. to cross-cutting capacity. Air jet from motor keeps work surface dust-free. Motor cord automatically adjusts to movements of the carriage. 4100 RPM universal motor develops 1 $\frac{3}{4}$ HP (115-230-volts, 50-60-cycle AC-DC). Built-in safety clutch resists burnout caused by abuse or overload. *UL approved*. No special wiring necessary.

(Do not order before June 1st.)

99 M 2930N—Shpg. wt. 125 lbs. . . . \$199.00

It's ha
be used
a whole
anyone c
practice
cabinet w
Accura
venient,
project c
Precisi
sure prof
after tim
You ca
cutting p
stops at
with fixe
rotates 36
Saw gl
large pre
to provid
light tou
In a la
back and
filled saw
was no cl
that CRA
Special

PLUS
POWER

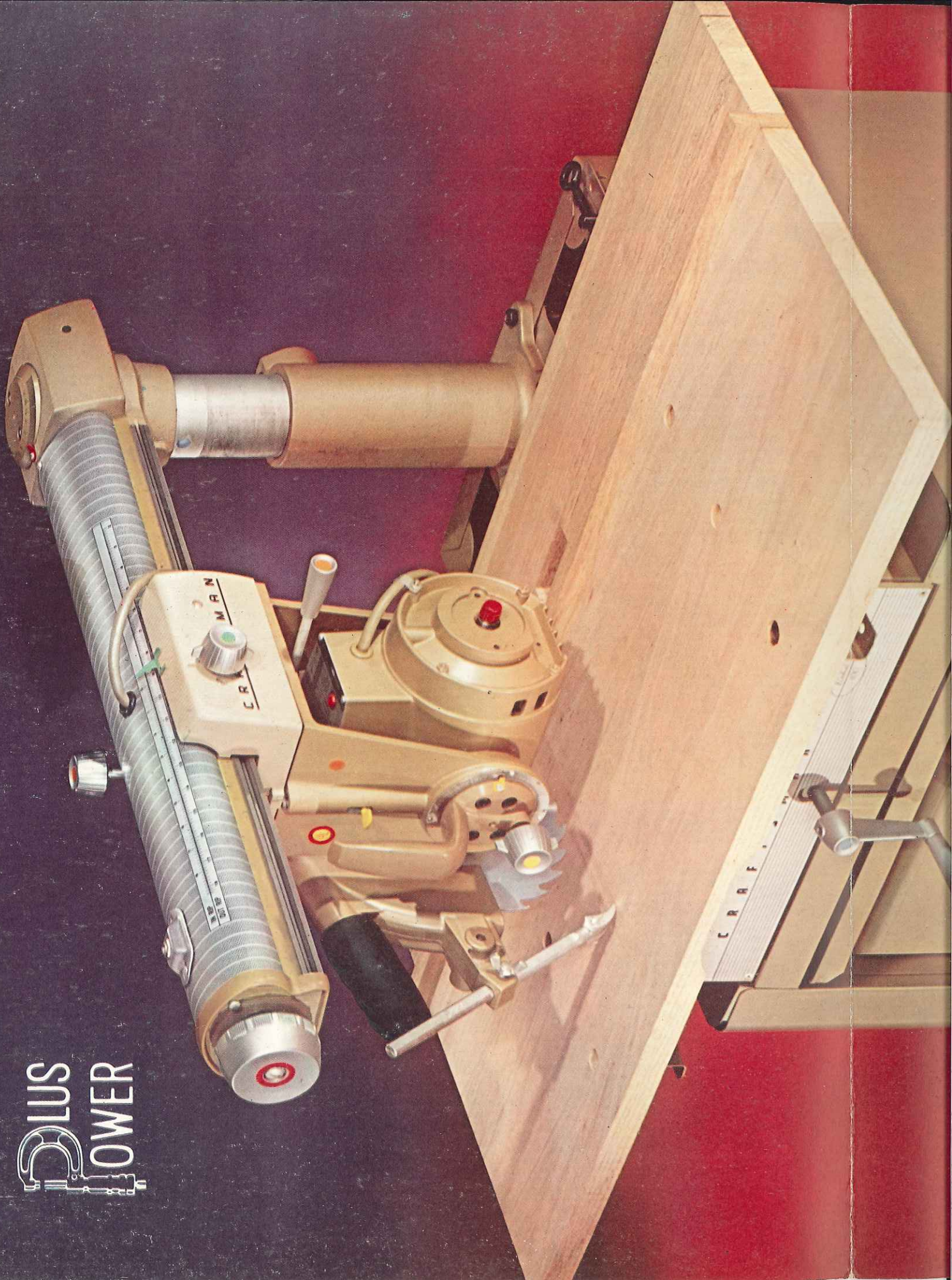

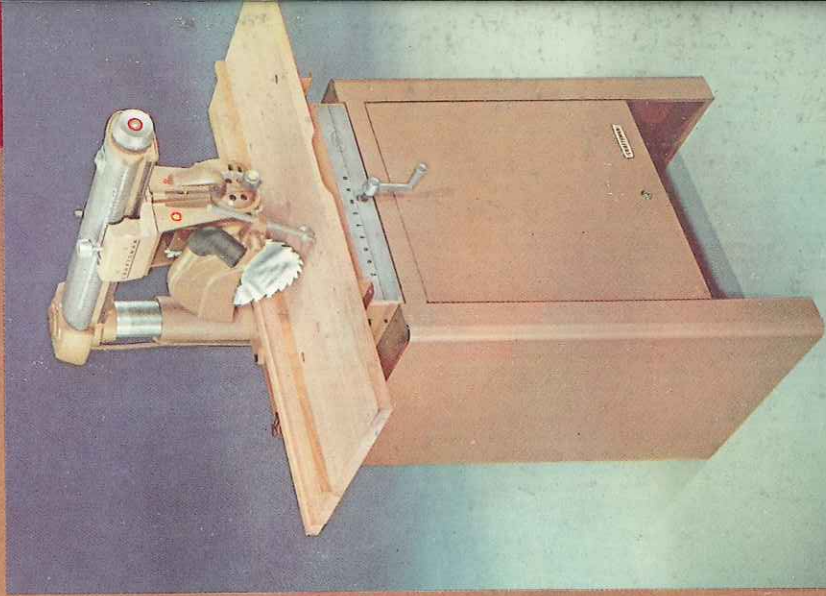

Store tools, accessories safely
in dust-free cabinet . . . drop-front slides
down over drawers and locks

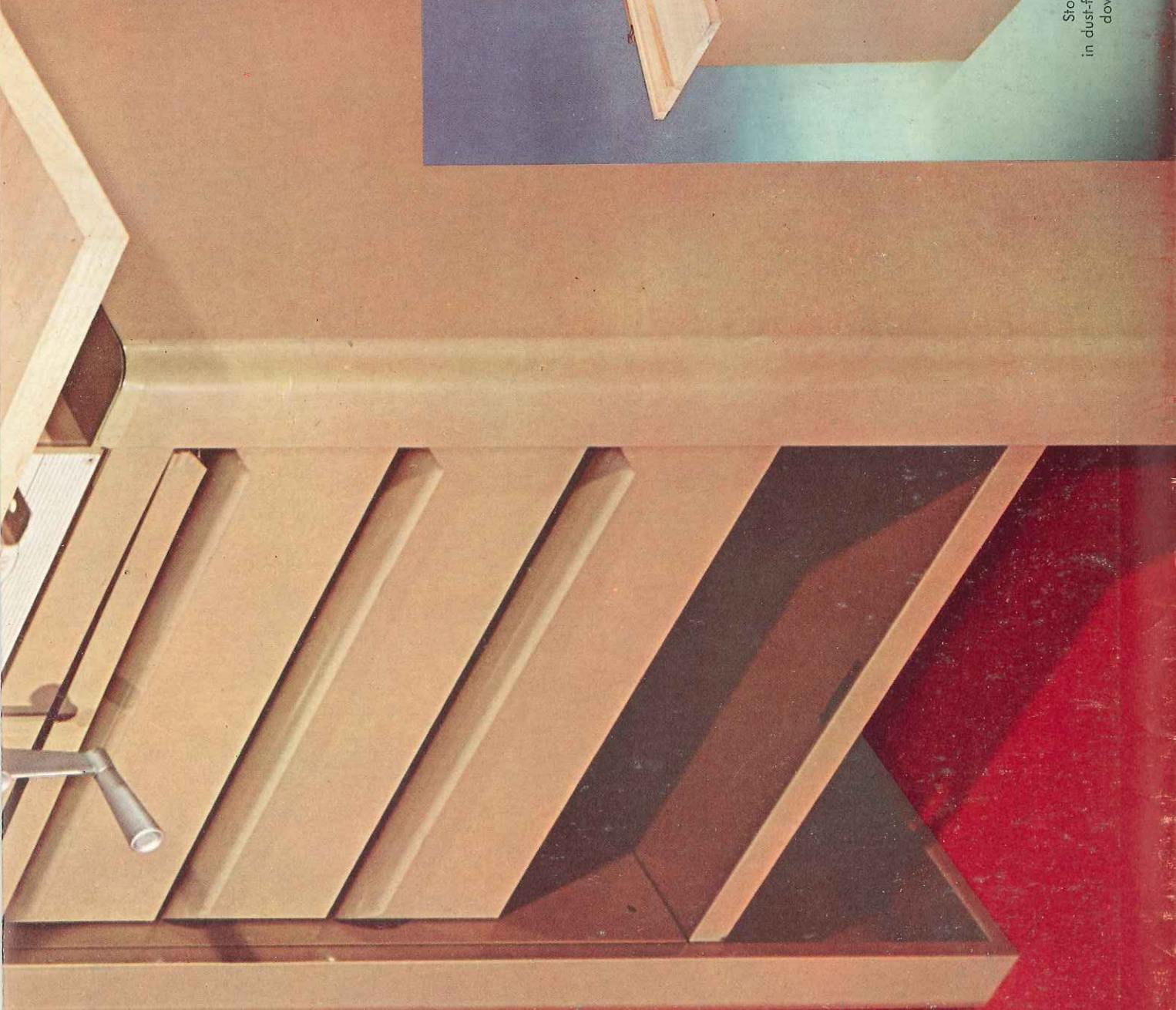

It's
be us
a wh
anyon
practi
cabine
Acc
venier
projec
Pre
sure p
after
You
cuttin
stops
with f
rotate
Saw
large
to pro
light t
In a
back
filled s
was n
that C
Spe

T-2i
Schweider
To 81200
295

Our best Radial Saw—develops 2 HP!

10-inch CRAFTSMAN Accra Arm Saw

Ruggedly built for continuous-duty operation
Just one tool . . . yet does practically anything with wood

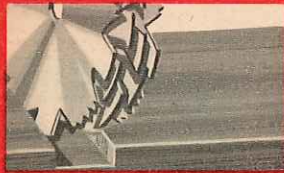

DADOES

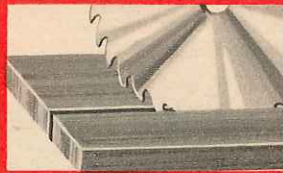

RIPS

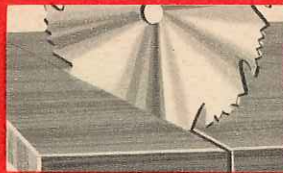

MITERS

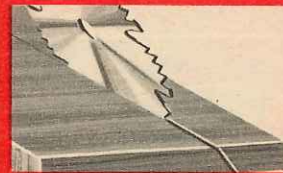

BEVEL CUTS



CROSSCUTS

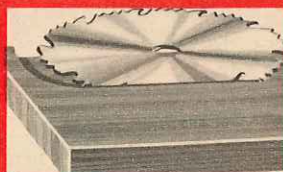

RABBETS

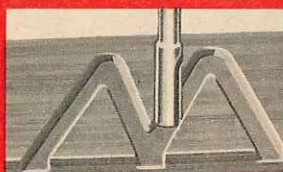

ROUTS

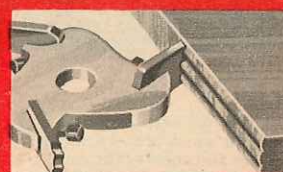

SHAPES

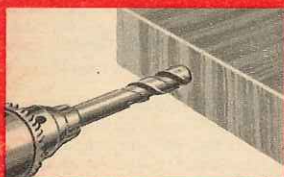

DRILLS

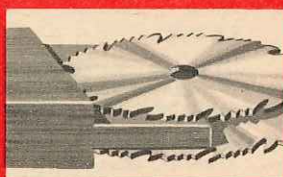

TENONS



SANDS

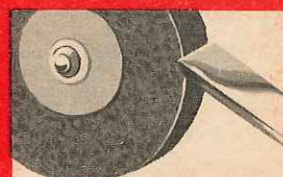

SHARPENS

Power enough to rip 2-inch lumber at high speed
Color-coded controls up front make work easy and safe
Laminated oak table has 825 square-inch work surface

Without Cabinet **\$239⁰⁰**
cash

It's hard to believe that one wood working tool can be used so many ways . . . practically does the job of a whole workshop itself. So easy to use, we're sure anyone can do woodworking magic after just a few hours practice . . . imagine doing your own handsome, quality cabinet work, home repairs and hobby projects.

Accurate tool operation made easy for anyone. Convenient, up-front, color coded controls insure fast project completion without sacrificing safety or speed.

Precision where you need it . . . positive controls insure professional accuracy . . . with cuts repeated time after time!

You can set and lock saw in almost any imaginable cutting position. Motor tilts 90° up or down with fixed stops at 0°, 45° or 90°; yoke swivels 180° right or left with fixed stops at 0°, 45° and 90° right and left; arm rotates 360° with fixed stops at 0° and 45° right and left. Saw glides along entire length of radial arm on 82 large precision ball bearings (34 in constant contact) to provide smoother more accurate cuts . . . a feather-light touch moves the entire carriage mechanism.

In a laboratory torture test the carriage was moved back and forth over 20,000 times while damp, resin-filled sawdust was blown over the mechanism . . . there was no clogging and a minimum of wear. Solid proof that CRAFTSMAN is your best buy in a radial arm saw.

Special important safety features: (1) Anti-kick-back

device prevents operator from being struck by material. Adjustable. (2) Safety key switch stops accidental starting . . . only your key will turn motor on or off. (3) Single-hand control with full-view cutting keeps you in command at all times.

Big, warp-resistant, laminated oak table . . . doubles as a work bench simply by swinging arm aside.

Single-phase 3450 RPM capacitor motor develops 2 HP (115-230-volt, 60-cycle AC) for high-speed clean-cutting action. Automatic thermal protector opens line circuit when motor temperature exceeds a safe limit due to overload. No special wiring needed for most cutting operations. *UL approved.* 5/8-in. diameter motor shaft. Takes 1/2-in. x 20-thread key chuck. With 10-in. all-purpose Kromedge blade. Cabinet not incl. See complete accessories on next page.

99 M 2900N—CRAFTSMAN Accra Arm 10-inch Radial Saw. Shipping weight 180 pounds. . . . \$239.00

CRAFTSMAN 3-drawer Cabinet for Accra Arm Saw. Heavy gauge, all steel; reinforced corners and ends. Drawers run on strong slide rails. Power-bronze finish.

99 M 1065N—Shipping weight 98 pounds. . . . \$39.95

Exclusive Mechanical Safety Brake. Stops blade quickly . . . eliminates hazard of blade "coasting" after motor has been turned off.

9 M 2950—Shipping weight 12 ounces. . . . \$9.95

SPECIFICATIONS

- Motor . . . develops 2 HP, 3450 RPM
- Blade size . . . 10 in. x 5/8-in. arbor hole
- Depth of cut (max.) 2 1/2 inches
- Depth of 45° cut (maximum) 2 1/8 inches
- Width of cross cut maximum in 1-inch stock . . . 16 inches
- Width of rip (max.) 24 inches
- Height adjustment 6 3/4 inches
- Dado size 8-in. diam. x 1 3/16 in.
- Dado depth (max.) 1 1/2 inches
- Miter index stops . . . Arm rotates 360°—fixed stops at 0°, 45° and 45° right and left
- Yoke Swivels 180° right or left—fixed stops at 0°, 45° and 90° right or left
- Bevel index Motor tilts 90° up or down—fixed stops at 0°, 45° and 90°
- Scales Miter, bevel, rip
- Table Laminated oak, 20 3/4 x 40 in. (four piece), adjustable
- Column diameter 3 inches
- Distance from center line of column to end of arm . . . 30 1/2 inches
- Overall height (column extended) 28 1/2 inches
- Switch Key type on top of arm

ONLY \$10 DOWN . . . See inside back cover for Special Easy Terms

CRAFTSMAN Accessories that fit BOTH Accra Arm and 9-inch Radial Saws

REG. U.S. PAT. OFF.

Attach quickly, easily . . . get even more work and fun from your saw

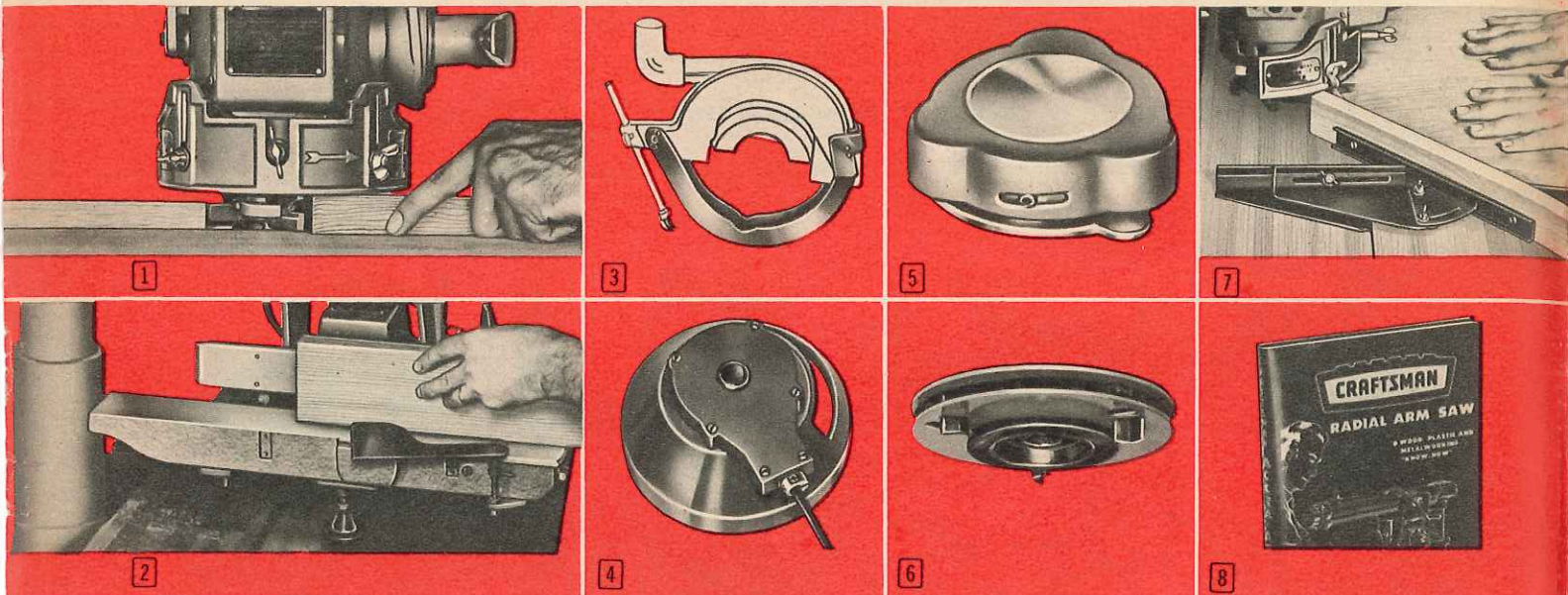

1 Molding Head and Shaper Guard. Protects operator during molding and shaping operations. Guard adjusts to the thickness of the work pieces being passed into molding and shaper blades . . . completely encloses cutter blades to give you maximum safety. Attaches very easily . . . it simply replaces saw blade guard. Heavy-duty cast aluminum . . . "power-bronze" color. 9 M 29007—Shipping weight 1 pound 4 ounces. . . . \$9.95

2 Jointer-Planer Attachment. Adapts Accra Arm and 9-inch Radial Saws for edge and surface planing operations (also fits CRAFTSMAN Electric Hand Saws). 7½-inch shoe in front of high-speed 2-knife cutter blade. Cuts 2½ inches wide to ½ inch deep. Rugged, diecast aluminum construction. Over-all length 20¾ inches. 12¾-inch detachable steel fence adjusts 45° for bevel cutting. Pulleys, belt, and bracket for mounting are included. With easy-to-follow instructions. Only \$4.00 down on Sears Easy Terms. 9 M 28459—Shipping weight 13 pounds. . . . Cash \$38.89

3 Floating Ring Guard. Permits clear, full view of operations at all times. Guard "floats" up over your work as it is fed into saw. You are provided maximum protection because your hands are always safely away from the saw blade. Shipping weight 1 pound 8 ounces. 9 M 29005. . . . \$4.95

4 Sabre Saw Attachment. Cuts intricate designs and makes blind cuts. Maximum depth of cut is 2 in. . . cuts 2x4. No belts or pulleys required to operate; simply attaches directly onto motor shaft like saw blade. "Power-bronze" finish. 9 M 2952—Wt. 2 lbs. 8 oz. \$14.95

5 Exclusive Safety Brake. This mechanical brake attaches easily and is very simple to operate. With finger-tip control . . . a quick twist and blade stops almost instantly; eliminates blade "coasting" . . . saves time . . . insures fast, safe set-up changes. Wt. 12 oz. 9 M 2950. . . . \$9.95

6 Rotary Surface-Planer Attachment. Here's an easy, economical way to increase your saw's versatility. Three quick-cutting blades remove stock swiftly, and leave an extra-smooth surface. Has ½-inch x 20 threaded bore. You can attach it in a wink. Shipping weight 2 lbs. 2 oz. 9 M 2951. . . . \$6.98

7 Shaper Fence. Full 3-inch movement forward or backward, plus full 45° angular adjustment for both right and left sides. Holds most any type work piece to insure accuracy throughout operation. May also be used as regular work fence. Ideal support when cutting picture frames, or when trimming, shaping and molding. "Black Oxide" finish. 9 M 2953—Shpg. wt. 2 lbs. 15 oz. \$6.98

8 CRAFTSMAN Radial Saw Book. 192 pages with over 200 illustrations. Includes all operations of the Accra Arm and 9-in. Radial Saws. Contains information on materials, wood-working techniques, etc. Looseleaf book encased in plastic. 9 M 2955—Shpg. wt. 1 lb. . . . \$3.95

More Accessories (available in this catalog) for Accra Arm, 9-in. Radial Saws

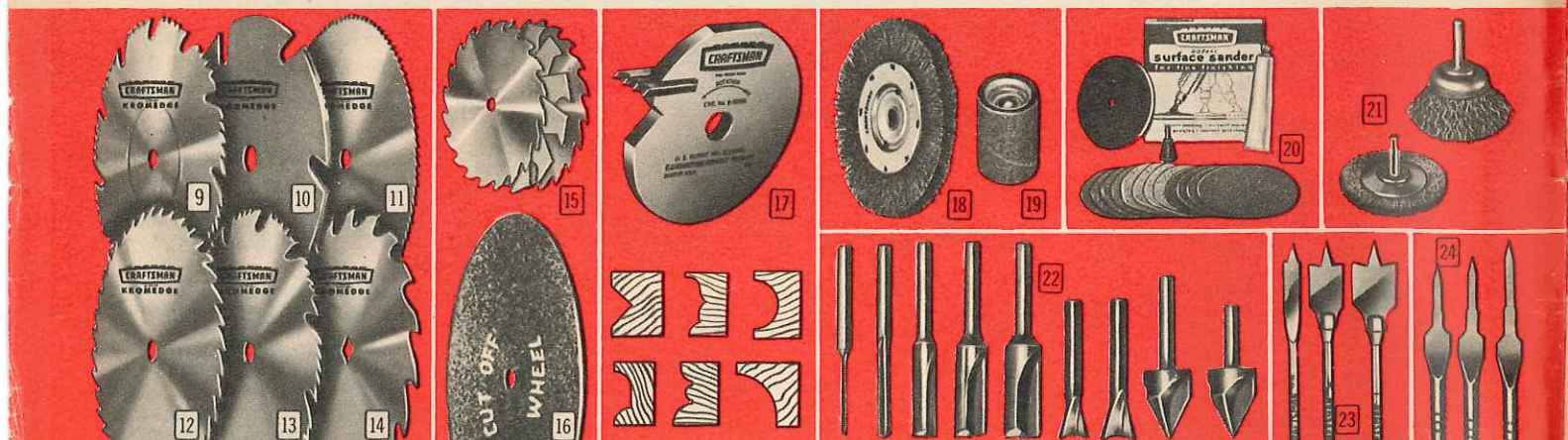

ACCESSORY	Catalog Number	See Page
(9) 10-inch Hollow-ground Blade	9 M 3239	12
(10) 10-inch Carbide-tipped Blade	9 M 3245	12
(11) 10-inch Crosscut Blade	9 M 3235	12
(12) 10-inch Kromedge Rip Blade	9 M 3236	12
(13) 10-inch Kromedge Comb. Blade	9 M 3237	12
(14) 10-inch Chisel-tooth Comb. Blade	9 M 3240	12
(15) 8-inch Dado Set	9 M 3247	13
(16) Cut-off Wheel	9 M 6465	32
(17) Molding Head Set	9 M 3215	13

ACCESSORY	Catalog Number	See Page
(18) Wire Wheels	9 M 6480-82-83	34
(19) Sanding Drum	9 M 25245	34
(20) *Finish Sanding Kit	9 M 2847	53
(21) Wire Brushes	9 M 6488-89-90	34
(22) *Router, Dovetail, Carving Bits	9 M 2400-01-02-03-04, 2410-11-15-16	29
(23) *Power Wood Boring Bits	9 M 2092	52
(24) *Wood Screw Pilot Bits . . . use to countersink or counterbore	9 M 4203-04	52

*For use with Chuck 9 M 29803 (sold on page 42). Auxiliary shaft fits any keytype chuck with ½-inch x 20 thread.

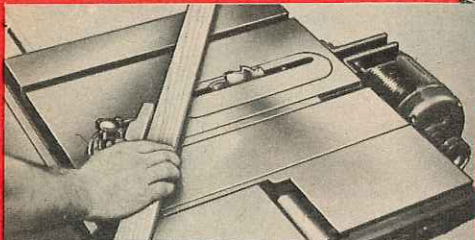
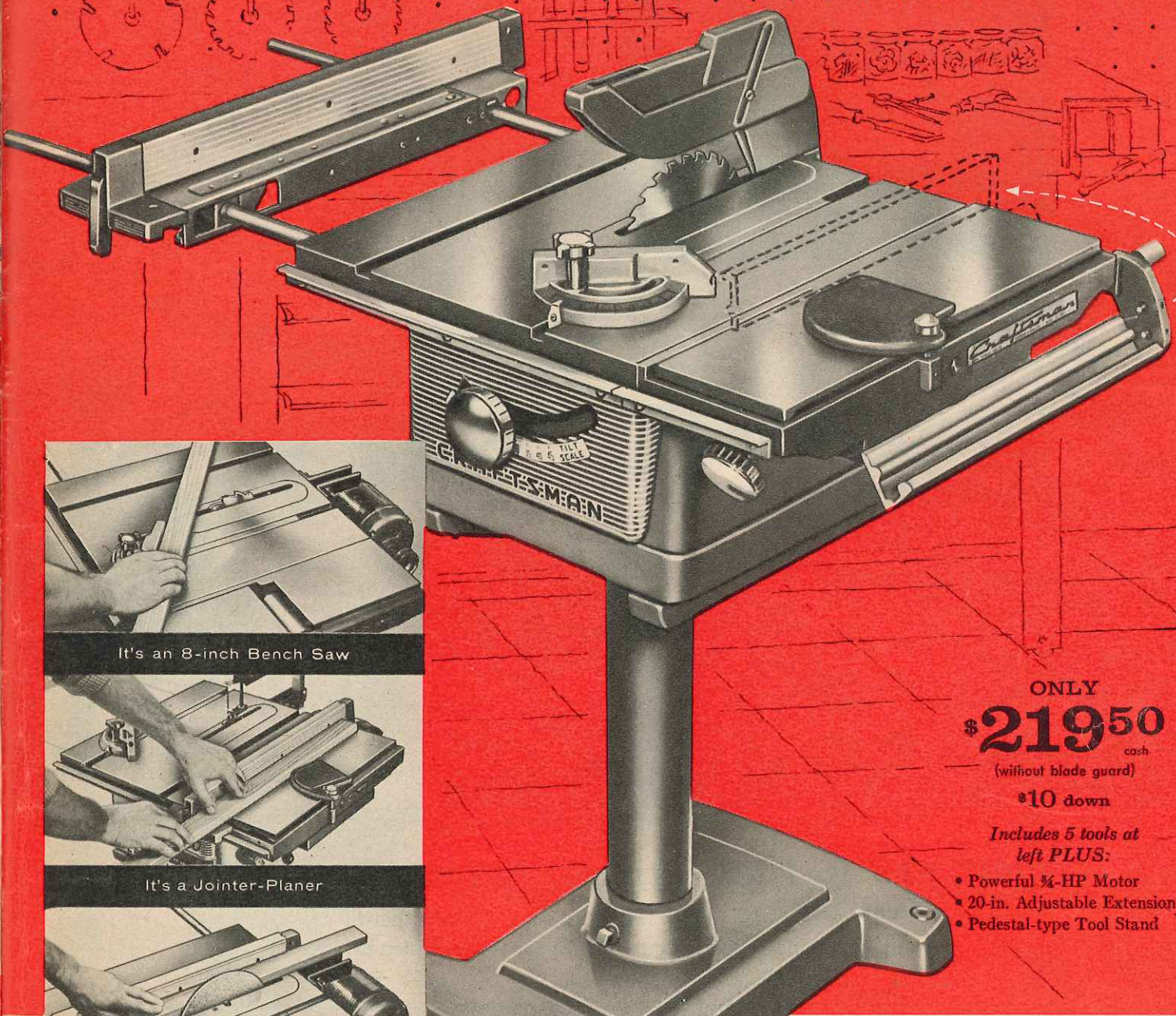

It's an 8-inch Bench Saw

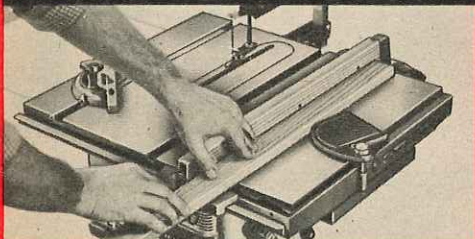

It's a Jointer-Planer

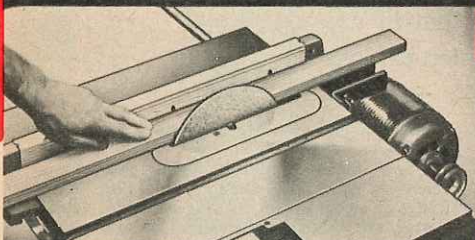

It's a Disc Sander

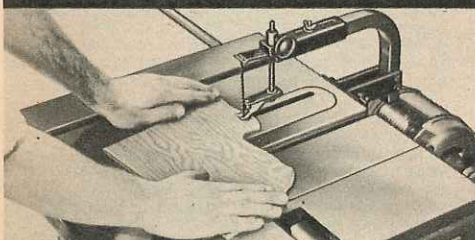

It's a Jig Saw

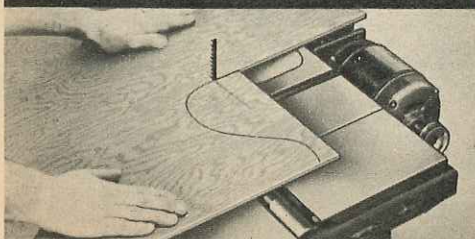

It's a Sabre Saw

ONLY
\$219⁵⁰
cash
 (without blade guard)

\$10 down

Includes 5 tools at left PLUS:

- Powerful ¾-HP Motor
- 20-in. Adjustable Extension
- Pedestal-type Tool Stand

CRAFTSMAN 5-Tool Power Shop

REG. U.S. PAT. OFF.

You can saw, joint, plane and sand with one compact unit!

Save Money: Costs you far, far less than five separate power tools with individual motors and stands or benches.

Save Space: Power Shop fits in area only 3½x2 feet, yet gives you up to 780 square inches of working surface.

Save Time: All 5 tools operate from one motor, one mount . . . no need to shift motor from one tool to another.

Big 17x20-in. saw table plus 20-in. sliding extension and jointer-planer table give up to 780 sq. in. of working surface. *Look what you get:*

Heavy-duty 8-inch Tilting-arbor Bench Saw. Single handwheel controls blade height and tilt . . . tilts to 45° . . . cuts to 2½ inches. Floating motor mounts provide automatic belt tension. With miter gauge, rip fence, V-belt, pulleys and 8-inch chisel-tooth combination blade (¼-inch center hole).

4½-inch Jointer-Planer. Adjustable fence folds under table (see arrow above) . . . jointer-planer acts as saw table extension. Micro-adjustment aligns 2 steel blades . . . cut to ¼-in. depth. Adjustable front table. With V-belt, pulleys, adjustable fence.

Jig-Sabre Saw Attachment. Sabre saw permits intricate cuts on big 4x8-foot panels. Cuts to 2½ inches depth. Jig saw arm permits delicate jig, fret and scroll work. Cuts to center of 20-inch circle. Takes either 4 or 5-inch blade.

8-inch Aluminum Sanding Disc. Use big saw table, miter gauge and rip fence for sanding. You can easily finish sand or remove surface.

Big ¾-HP 3450 RPM Capacitor Motor. For use with 115-230-volt, 60-cycle AC. Power for deep saw cuts, plus speed for jointer-planer or jig saw.

Adjustable Saw Table Extension . . . steel. Acts as both fence and support for extra-wide ripping jobs.

Cast semi-steel Pedestal-type Tool Stand.

99 M 13305N7—Complete Outfit. Includes everything listed at left and above. Without blade guard. Shipping weight 212 pounds. Only \$10 down, \$10.50 monthly. Cash \$219.50

99 M 2184K—Jointer-Planer Extension. Fits power shop above and bench saws 99M2104L, former No. 2216. Adjustable fence not included. Shipping weight 30 lbs. \$39.95

9 M 2181—Tilting Fence for jointer-planer 99M2184K above. Shipping weight 4 pounds. \$9.50

9 M 21046—Saw Blade Guard Assembly. Shipping weight 2 lbs. 10 oz. 6.59

Buy it now on Easy Terms . . . see inside back cover

*"My power tool shop
gives me a wonderful
relaxing hobby"*

P.S. His wife and his
doctor think so, too

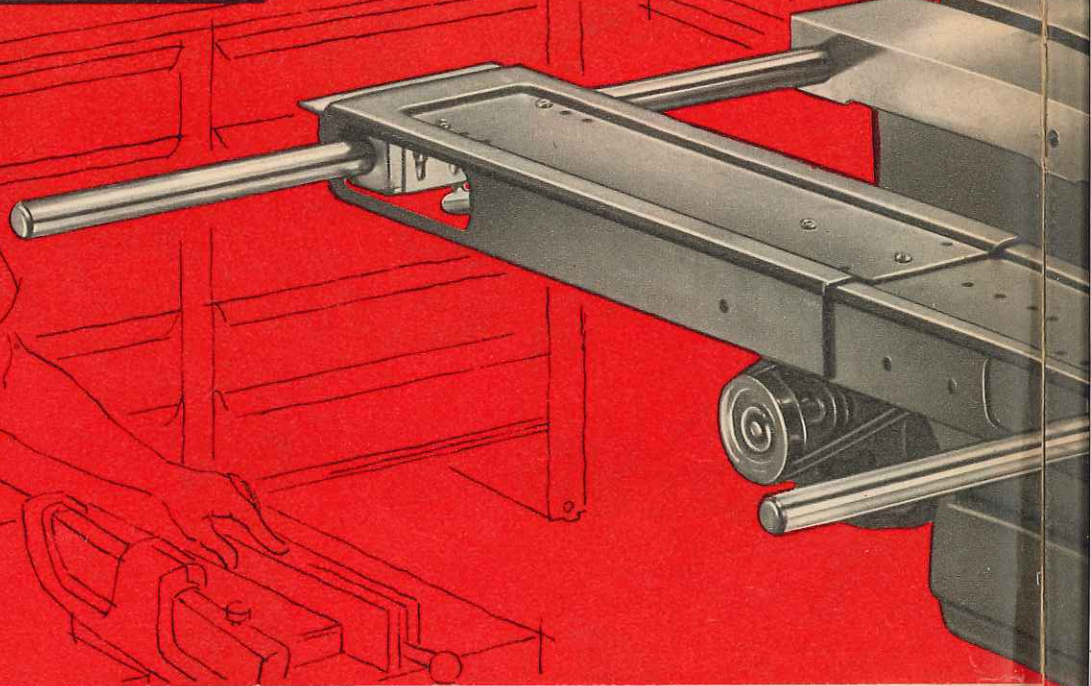

CRAFTSMAN 10-inch Tilting Arbor Bench Saw

REG. U. S. PAT. OFF.

*Built-in accuracy makes it easy to turn out cuts that fit . . .
up to 3 3/8-inch depth of cut, big capacity 27x20-inch table!*

SPECIFICATIONS

- Depth of cut (maximum) 3 3/8 in.
- Blade Kromedge chisel-tooth comb.
- Blade size 10-in. diam.; 5/8-in. center hole
- Table size 27 in. long; 20 in. wide
- Distance in front of blade:
(at full 3 3/8-in. depth of cut) 13 in.
(at 1-in. depth of cut) 15 1/4 in.
- Table height 12 13/16 in.
- Blade tilt (maximum) 45°
- Length of fence 32 3/4 in.
- Dado capacity (using 6-in. dado saw):
1 3/16 in. wide; 1 1/8 in. deep
- Bearings . . . 2 sealed ball, lubricated for life
- Blade speed:
9000 peripheral ft. per minute (approx.)
- Arbor speed recommended . . . 3450 RPM
- Motor recommended
(minimum) 3/4 HP 3450 RPM
- Base size 14 1/4 in. wide; 16 3/4 in. long
- Overall height 12 13/16 in.
- Overall width 23 3/4 in.
- Overall length 33 1/4 in.
- Mounting dimensions
(hole centers) 11 1/4 x 13 1/8 in.
- Machine pulley (included) 2 1/4 in.
- Motor pulley (included) 2 1/4 in.
- V-belt (incl.) 43 in. long; 3/2 in. wide

Our Best Bench Saw—only \$1.00 more per month than smaller capacity 8 and 9-inch bench saws on page 10 . . . use Sears Special Easy Terms. Meets rigid requirements of large industrial shops. For outstanding quality, mechanically superior features, exceptional performance, we're convinced you cannot match this saw at anywhere near this price!

Advantages found in NO other bench saw. Work goes much faster, easier because only brief adjustments of accessories are necessary for the next step on your job. Working surface from blade to front of table is 13 inches at full (3 3/8-inch) depth of cut; 15 1/4 inches at 1-inch depth of cut. All hand wheel controls are conveniently located for easy adjustment.

Massive, extra-heavy duty construction. Extraordinary accuracy and stability! More rigid saw base and stronger motor support, with pivot arm for smoother operation. Tension device between motor mounting plate and support reduces transmission of vibration and troublesome jumping of motor.

Table never tilts . . . work always lies flat. Motor, blade and arbor tilt together as a unit, any angle up to 45 degrees; belt never twists. Blade raises and lowers to vary depth of cut from 0 to 3 3/8 inches.

Sealed precision ball bearings; lubricated for life. Extra-large 27x20-inch heavy cast semi-steel table, now takes snap-in type table inserts (listed separately at right). Precision ground; grooved on both sides of blade for miter gauge work.

Wiping and cutting actions clean sawdust from tilt and lift screws . . . NO more stiff and tight controls. Positive stops for blade height and tilt. Holes provided in fence for mounting facing boards and dadoing, etc. Rip fence usable on either side of blade clear to table edge. Single control lever locks fence at both ends (not just in front). 10-inch Kromedge chisel-

tooth combination blade (5/8-inch center hole) gives full 3 3/8-inch depth of cut.

Power-bronze color. With blade, miter gauge, rip fence, rip fence rack, machine and motor pulleys, V-belt and motor mount. Guard assembly, hold-down, motor, side table extensions and stand not included.

99 M 2999N—CRAFTSMAN 10-inch Bench Saw without blade guard assembly, hold-down, motor, side table extensions or stand. Shpg. wt. 144 lbs. \$5.00 down. Cash \$114.95

99 M 1366N2—Saw above, with CRAFTSMAN 3/4-HP 3450 RPM capacitor motor (115-230-volt, 60-cycle AC). Shpg. wt. 176 lbs. \$5.00 down, \$7.00 monthly. Cash \$143.50

99 M 1367N2—Saw above with CRAFTSMAN 1-HP 3450 RPM motor (115-230-volt, 60-cycle AC). Shpg. wt. 182 lbs. \$5.00 down \$7.50 monthly. Cash \$150.00

9 M 2178—Adjustable Table Extension. Adds 20 in. to table. Shipping weight 13 lbs. Each \$11.98

99 M 2769C—Side Grid-type Table Extension. Cast semi-steel. Widens table 10 inches on either side. With bolts and rip fence rack extension. Size 27x10 in. Shipping weight 20 lbs. Each \$14.95

99 M 2228L—CRAFTSMAN Tool Stand. (Shown with saw.) Pedestal type. Base 16 1/4 in. wide, 21 1/4 in. long, 5 3/4 in. high; 4 caster holes. Steel column 3/2-in. diameter, 21 in. long. Shpg. wt. 61 lbs. \$3.00 down, \$4.00 monthly. Cash \$27.95

9 M 2819—Set of 4 Casters for above. Shpg. wt. 1 lb. 4.69

9 M 2993—Saw Guard Assembly. Automatic leveling guard tilts with blade; plastic insert. With guard, splitter, bracket, non-kick-back pawls. Shipping weight 6 pounds. \$12.50

9 M 29998—Dado Insert. For saw above. Steel, snap-in type. Accommodates dados up to 6 inches. Shpg. wt. 8 oz. \$1.98

9 M 29992—Steel Molding Head Insert. For saw above. Snap-in type. Shipping weight 11 ounces. \$1.98

9 M 21205—CRAFTSMAN Powr-Pak. (Not shown.) Safe, convenient way to hook up tools. Shpg. wt. 1 lb. 3 oz. \$4.29

9 M 2761—Hold down for Miter Gauge. (Shown on saw.) Clamps work against gauge and table. Spring-loaded; instant thumb release. Shipping weight 2 pounds 10 ounces. \$9.95

BUY ON SEARS SPECIAL EASY TERMS! . . see inside back cover



Do all this and more with this saw and proper accessories!

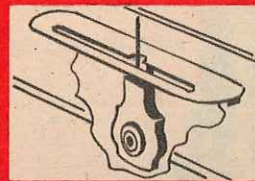

Sabre Saw . . . attaches directly to motor shaft

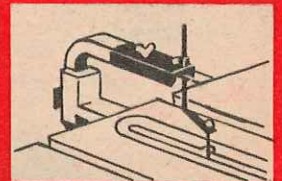

Jig Saw . . . adds cutting versatility at low cost

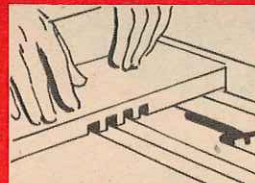

Dado and Groove Cuts . . . dado head gives precision, accuracy

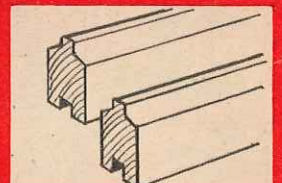

Tongue and Groove . . . use molding head in place of blade

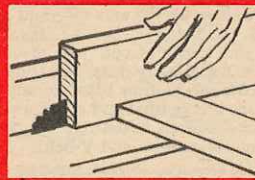

Edge Cutting . . . no special attachments necessary

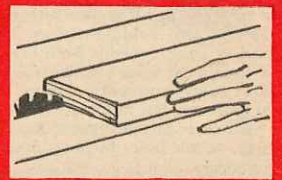

Rabbet Cuts . . . simply use rip fence or miter gauge as guide



Metal Cutting . . . use cut-off wheel in place of blade

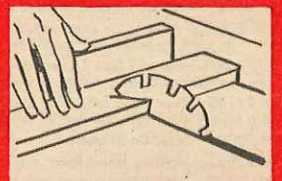

Miter Cuts . . . gauge assures accurate, perfect fitting joints

Only \$5 down
\$6 monthly

\$114⁹⁵ cash

Without saw guard,
hold-down, motor, stand
or table extensions

CRAFTSMAN

REG. U. S. PAT. OFF.

Tilting Arbor Saws



\$98⁵⁰
cash
\$5 down
\$5 monthly



\$79⁹⁵
cash
\$5 down
\$5 monthly

SPECIFICATIONS

	99M2000N (9-inch saw)	99M2104L (8-inch saw)
• Depth of cut (maximum)...	3 inches	2 1/2 inches
• Blade type.....	Chisel-tooth combination	Chisel-tooth combination
• Blade size (diam.; cen. hole).	9-in. diam.; 5/8-in. hole	8-in. diam.; 1/2-in. hole
• Dado capac. (6-in. dado saw)	1 1/2-inch depth; 1 1/8 inch width	1 1/2-inch depth; 1 1/8-inch width
• Blade tilt (maximum).....	45 degrees	45 degrees
• Bearings (life lubricated)...	2 sealed ball	2 sealed ball
• Table size.....	18x24 inches	17x20 inches
• Distance in front of blade...	At 3-in. depth of cut: 12 inches; 1-in. depth of cut: 12 1/2 inches	2 1/2-in. depth of cut: 9 1/2 inches; 1-in. depth of cut: 10 1/16 inches
• Miter gauge stops.....	90 and 45, right and left
• Rip fence length.....	(overall) 30 5/8 inches (work face) 23 3/8 inches	24 inches
• Table height.....	11 1/8 inches	11 1/4 inches
• Base size.....	20 5/8x16 1/4 inches	14 13/16x15 1/16 inches
• Blade speed.....	9500 peripheral feet per minute	9500 peripheral feet per minute
• Motor recommended (min.)	3/4 HP 3450 RPM	1/2 HP 3450 RPM
• Machine pulley (included)...	2-inch (5/8-in. bore)	2-inch; keyed to arbor
• Motor pulley (included)....	2 1/2-inch (3/8-in. bore)	2 1/2-in. (3/8-in. bore; keyed)
• V-belt (included).....	36 in. long; 1/2 in. wide	40 in. long; 1/2 in. wide
• Over-all measurements.....	14 5/16 in. high; 18 in. wide; 33 9/16 in. long	14 in. high; 17 in. wide; 26 1/32 in. long.

9-inch Saw with 3-inch depth of cut

Exact-I-Cut shows exact size of saw kerf and aligns blade with cut mark on wood. No "miscuts" caused by guessing blade width! Die-cast, adjustable miter gauge for accuracy at all angles with pre-set indices at 90° and 45° right and left. Use with 9 M 2761 hold-down (not included; see below). "Mono-Control" one hand wheel at front controls both blade tilt and depth of cut. Just move wheel in or out to change from one control to the other. Heavy-duty construction. Heavily ribbed table; automatic tension unit holds mechanism tilted to any angle. Integral motor mount automatically maintains belt tension and alignment. 18-in. easy-to-read scale in fence guide bar. 9-in. chisel-tooth Kromedge combination blade (5/8-in. center hole. Includes machine, motor pulleys and V-belt.

- 99 M 2000N—Without guard assembly, motor, side extension, adjustable extension, roller extension, hold-down or bench. Shipping weight 89 pounds..... \$98.50
- 99 M 1359N2—Like 99 M 2000N; with CRAFTSMAN 3/4-HP 3450 RPM (115-230 volt, 60-cycle AC) motor. Shipping weight 121 pounds..... \$126.95
- 99 M 1355N2—Like 99 M 2000N; with CRAFTSMAN 1-HP 3450 RPM (115-230 volt, 60-cycle AC) motor. Shipping weight 132 pounds..... \$133.95
- 9 M 2178—Adjustable Table Extension. Adds 20 in. of width to saw table. Wt. 13 lbs. 11.98
- 99 M 2085C—Side Table Extension. For either side. Grid-type; semi-steel. 9 in. wide x 24 in. long. With 9-in. front rip fence rack extension. Scale insert not included. Shpg. wt. 16 lbs..... \$11.98
- 99 M 2088L—Set of 2 Side Table Extensions. Two 99 M 2085C extensions with 18-in. front rip fence rack extension and 36-in. graduated scale insert. Extend table to 36x24 in. Shpg. wt. 32 lbs. \$23.95
- 9 M 22165—Rear Roller Extension. (Shown on saw.) Fits both 99 M 2104L (at right) and 99 M 2000N bench saws. Roller type; for rear of saw only. With bolts. Shipping weight 7 lbs..... \$8.39
- 9 M 20006—Steel Dado Insert. For use with above saw. Shipping weight 15 oz..... 1.98
- 9 M 20001—Molding Head Insert. For above saw. Steel. Shipping weight 1 pound..... 1.98
- 99 M 2228L—CRAFTSMAN Tool Stand. Steel pedestal type; won't tip. Base 16 3/4 in. wide, 21 1/2 in. long. 5 1/8 in. high. 4 caster holes. Column 3 1/2-in. diam., 21 in. long. Shpg. wt. 61 lbs..... \$27.95
- 9 M 21046—Saw Guard Assembly. (Shown on saw.) Automatically levels with work. With guard, splitter, non-kickback pawls. Shipping weight 2 pounds 10 ounces..... \$6.59
- 9 M 2761—Hold-down for Miter Gauge shown on saw. Clamps work against gauge and table. Instant thumb release. Shipping weight 2 pounds 10 ounces..... \$9.95

8-inch Saw with 2 1/2-inch depth of cut

Precision-ground cast semi-steel table with machined miter slots on both sides. Blade and arbor tilt together—any blade angle to 45° . . always level surface. "Floating Drive" integral motor mount controls belt tension . . smother vibration. "Mono-Control" one-hand-operated wheel at front controls both tilt and depth of cut. Automatic tensioning holds saw in fixed setting.

Die-cast aluminum pickoff rip fence . . removable at any point on table . . for use on either side of blade—single lever locks both ends—front and back! Easy-to-read indicator dial . . accurate tilt. 8-inch chisel-tooth combination blade (1/2-inch hole) up to 2 1/2-inch depth of cut. Includes miter gauge, fence, machine and motor pulleys and 1/2x40 inch V-belt.

- 99 M 2104L—Saw without blade guard, motor, side extensions, roller extension, or bench. (See below for accessories.) Shipping weight 66 pounds..... \$79.95
- 99 M 1349L2—Like 99 M 2104L; with CRAFTSMAN 1/2-HP 3450 RPM (110-120 volt, 60-cycle AC) motor. Shipping weight 94 pounds..... \$104.50
- 99 M 1348L2—Like 99 M 2104L; with CRAFTSMAN 3/4-HP 3450 RPM (115-230 volt, 60-cycle AC) motor. Shipping weight 98 pounds..... \$108.50
- 9 M 2178—Adjustable Table Extension. Adds 20 in. of width to table. Shpg. wt. 13 lbs. 11.98
- 99 M 21047C—Side Table Extension. For either side. Grid-type; semi-steel. With fence rack extension, bolts. Shipping weight 15 pounds..... \$10.50
- 9 M 22165—Rear Roller Extension. (Shown on saw.) Fits 99 M 2104L above and 99 M 2000N at left. Roller type; for rear of saw only. With bolts. Shipping weight 7 pounds..... \$8.39
- 9 M 2405—Steel Dado Insert. For use with above saw. Steel. Shipping weight 14 oz..... 1.69
- 9 M 2201—Molding Head Insert. For above saw. Steel. Shipping weight 1 lb..... 1.69
- 9 M 21046—Saw Blade Guard Assembly. (Shown on saw.) Automatically levels with work. With guard, splitter, non-kickback pawls. Shipping weight 2 pounds 10 ounces..... \$6.59
- 99 M 2228L—CRAFTSMAN Tool Stand. (Shown on saw.) Pedestal type. Massive, heavy, all steel. Will not tip. Base 16 3/4 inches wide, 21 1/2 inches long. 5 1/8 inches high; 4 caster holes. Column 3 1/2 inches in diameter, 21 inches long. Shipping weight 61 pounds..... \$27.95
- 9 M 2819—4 Casters. Fit tool stand 99 M 2228L. With hex socket wrench. Shpg. wt. 1 lb.... 4.69



\$54⁹⁵
 cash
 Without motor,
 extensions, bench
\$5 down
\$5 monthly

8-in. Tilting Bench Saw . . 2 1/4-in. depth of cut

CRAFTSMAN quality . . budget priced . . designed to give you all the safety and precise results you get with tilting arbor bench saws sold at higher prices. Your work always lies flat . . table doesn't tilt as on so-called "bargain" power saws. You get a 7 3/16-in. working area ahead of blade at maximum depth of cut . . 8 1/2 in. at 1-in. depth. Ball-bearing saw arbor. Integral floating motor mount set at a precise angle to reduce belt-twisting . . automatic belt tensioning.

Pick-off fence lifts off from any part of table. Single lever locks both front and rear ends to table. Sturdy, cast semi-steel table. Sealed ball bearings never need lubricating. Positive front controls positioned for easy access. 8-in. chisel-tooth combination blade (3/2-in. center hole). Blade guard, splitter, miter gauge, pick-off type rip fence, machine pulley.

99 M 2424L—Without motor, extensions, bench. Shipping weight 49 lbs. \$54.95
 99 M 2424L12—With CRAFTSMAN 1/2-HP 3450 RPM sleeve bearing capacitor motor (110-120 volt, 60-cycle ACI, 2 1/2-in. motor pulley; 40-in. V-belt. Shpg. wt. 78 lbs. \$79.95

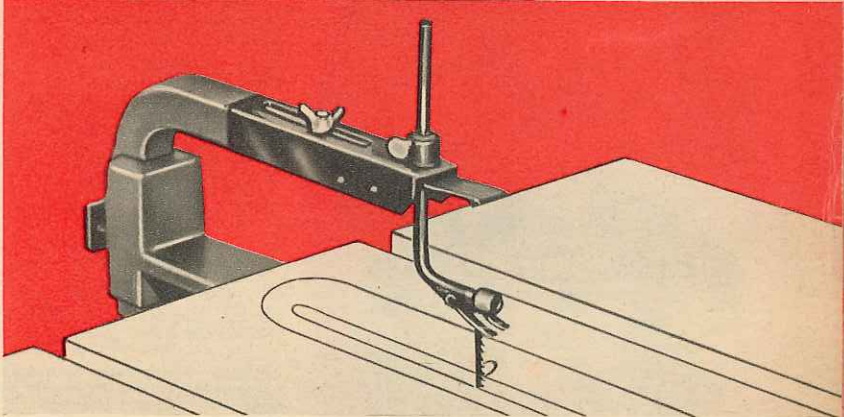
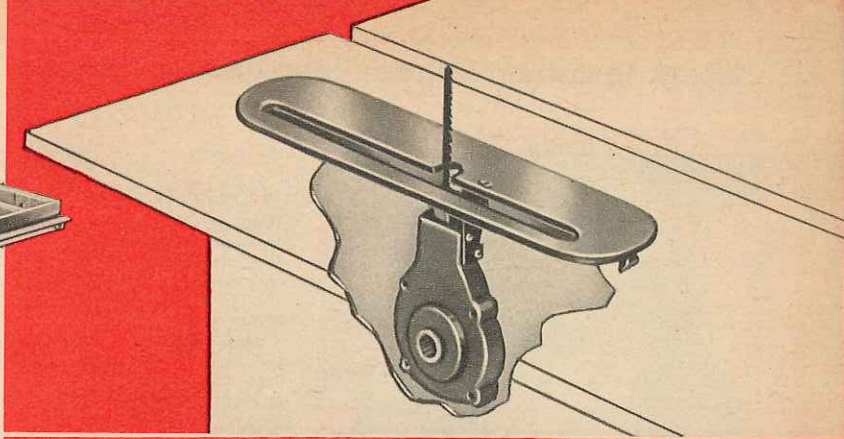

Jig and Sabre Saw Attachment \$18⁵⁰

Get more pleasure, more work out of your bench saw with this time-saving attachment! Easily attaches directly to saw arbor . . as easy as changing blades. Fits most 1/2 or 5/8-inch diameter arbor saws. Fits bench saws shown on page 10 (doesn't fit 99 M 2424L shown at left). Completely enclosed bearing never needs lubrication. Saw blades not included, Sabre saw for irregular cuts—2 1/2-in. depth of cut. For replacement blades see page 22. Use jig saw for finer, intricate cuts. Cuts to center of 20-inch circle. Takes 4 or 5-inch pin-end jig saw blades (for replacements see page 22).

9 M 2175—Shipping weight 4 pounds 5 ounces. \$18.50

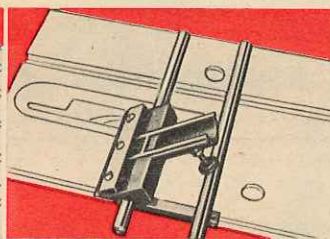
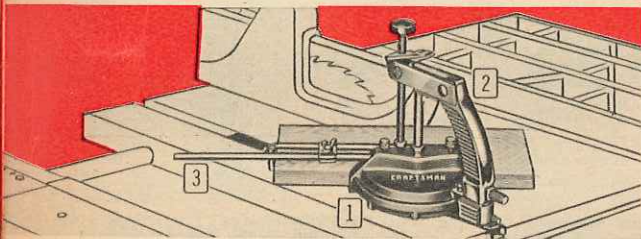

1 CRAFTSMAN Miter Gauge. For positive, accurate alignment. Aluminum head. Positive adjustable stops at 0° to 45°, right and left. Fits most 3/4x3/8-inch miter slots. 18-inch length. Fits bench saws 99 M 2000N, 99 M 2104L, former floor model saws 2242, 2444; band saw 99 M 2425L on page 19; high speed shaper 99 M 2392N on page 23; disc sanders 99 M 2250L, 99 M 2237L on page 24.
 9 M 2760—Shipping weight 5 pounds 2 ounces. \$9.95

2 Pistol-grip Hold-Down. For miter gauge above. Clamps work against gauge and rail. Spring loaded instant-action thumb release.
 9 M 2761—Aluminum. Shpg. wt. 2 lbs. 10 oz. \$9.95

3 Miter Gauge Stop Rods. For cross cuts, repetitive cutting jig or work stop. Fits miter gauge above; former numbers 2246, 2720.
 9 M 2125—Shipping weight 14 ounces. \$1.95

CRAFTSMAN Jointer-Planner Blade Sharpener Attachment. CRAFTSMAN and DUNLAP Bench Saws, others with miter grooves 3/8 to 3/4 inches wide, 5 inches from face of blade to center of left-hand miter slot. For blades up to 6 3/4 inches long.

With a cast iron holder, and steel guide bars. Use attachment with a 6x1 1/2-in. grinding wheel; 1/2-in. center hole. Wheel not included. Use Number 9 M 6412 on page 32. Shipping weight 8 pounds.
 9 M 2658. \$12.50

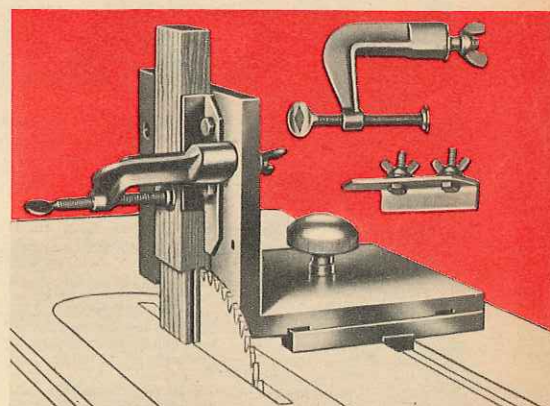

CRAFTSMAN Universal Jig
 Makes self-locking joints
\$13⁹⁵

With 8-inch Kromedge Tenoning Blade. Accurately makes the following joints: box, miter, rabbet, dado tongue and rabbet, tongue and groove, end lap, middle lap, open mortise tenon, and many, many more. Actual combinations and number of joints are limited only by your imagination.

Cuts accurate tenons to the full capacity of any saw. Safely holds material for cutting grooves on ends and edges. Adjustable to hold material up to 2 inches thick and any length or width. Attaches easily to any bench saw or shaper table with 3/4-inch miter slot. Strong, lightweight die-cast aluminum construction. Size: 6 1/2 inches high, 7 inches wide.

8-inch Kromedge tenoning blade cuts clean square bottom grooves 1/2 inch wide. Insures hairline joints . . full-surface glue bonds. Round center hole knockout bushed to fit 3/8 or 1/2-inch saw arbor. 2 "C" clamps, 2 holding plates.
 9 M 3231—With instructions. Wt. 6 lbs. 2 oz. . . . \$13.95
 9 M 3232—Replacement blade for above. Shipping weight 1 lb. 2 oz. 3.49

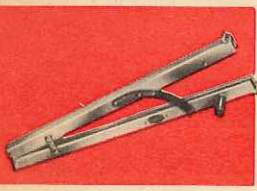
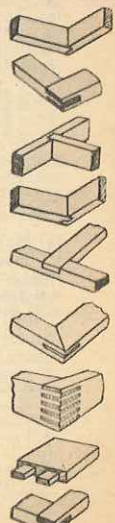

Taper Jig Attachment. Cuts tapers up to 3 inches per foot (or 15° angle). Metal scale makes it easy to cut tapers at any angle. Light in weight. Use on any bench saw or radial saw. Shipping weight 2 pounds 10 ounces.
 9 M 3233. \$4.98

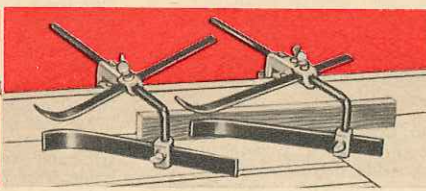

CRAFTSMAN Hold-down Attachment. Fits almost all bench saws, jointers and shapers. Fingers hold work from four directions at the same time. Attachment includes two clamps for attaching auxiliary rip fence (rip fence not included) to regular rip fence; two tempered steel "L" rods attach to clamps and hold down fingers; four holding fixtures that lock fingers to the "L" rods; includes four spring steel hold-down fingers. Also includes hardware for installation.
 9 M 3230—Shipping weight 3 lbs. 2 oz. . . . \$3.95

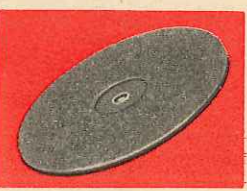

Sanding Wheels. Medium grit one side; coarse on the other.
 9 M 2274—8-in. diam. For 3/4 or 1/2-in. center hole. Cast aluminum. One flat side; other has 2° taper for fine jointing. Shpg. wt. 1 lb. 3 oz. . . . \$2.98
 9 M 2272—10-in. diam. For 3/4 or 3/8-in. center hole. Steel. Wt. 3 lbs. 12 oz. . . \$2.98
Replacement Discs for sanding wheels above. 3-in. center hole. Pkg. of 6: 2 fine, 2 medium, 2 coarse. State diameter desired.
 9 M 2273—8 in. Wt. 7 oz. 85c
 10 in. Wt. 10 oz. 98c

Build your order to \$20,
 buy on Easy Terms

Carbide-tipped Blades last 100 times longer than ordinary steel blades

\$9.98
8-in. diam.

Toughest saw teeth ever made... tungsten-carbide tips on Kromedge blade. Costs only a fraction of all the ordinary steel blades you'd wear out during life of one carbide-tipped blade. Cuts more smoothly, feeds more evenly, stays sharp longer and takes less power than regular steel blades.

Rips, crosscuts, miters and bevels. Resists stalling, kickbacks and clogging caused by pitch and tars. Tempered for longer cutting life. Rust resistant. Cuts all types of wood, most plastics, Formica, asbestos, aluminum and wallboard. Not for use on masonry of any kind, iron, steel or other ferrous metals such as alloy steels.

9 M 3245—8-tooth blades. (12-in. blade has 12 teeth). State saw blade diameter, center hole shape and size.

Diam.	Center Hole	Fits these saws	Shpg. wt.	Price
7 5/8 in.	*1 3/16-in. diamond	6-in. Skil-saw or		
	1/2-in. square..	Mall and Pet.....	1 lb. 2 oz.	\$8.98
6 1/2 in.	1 1/8-in. round..	6-in. Black & Decker...	1 lb. 2 oz.	8.98
7	*1 3/16-in. diamond	Skil-saw or		
	1/2-in. square..	Mall.....	1 lb. 6 oz.	9.49
8	*5/8-1/2-in. round	8-in. hand; bench saws.	1 lb. 12 oz.	9.98
8	1 3/16-in. square..	Skil-saw or		
	1/2-in. square..	Mall.....	1 lb. 12 oz.	9.98
8 in.	*1 3/8-in. round..	Black & Decker.....	1 lb. 12 oz.	9.98
9 in.	*5/8-in. round..	CRAFTSMAN 9-in. bench and radial saws...	2 lbs. 2 oz.	10.98
10 in.	*1-3/4-5/8-in. round.....	Bench; builders; radial; swing saws...	2 lbs. 6 oz.	11.98
12 in.	*1-3/4-in. round..	Bench; builders; radial; swing saws...	3 lbs. 9 oz.	17.98

†Nominal 6-in. blade... may be used on 6-inch saws.

9 M 3246—6-tooth blades. Kromedge blades, tungsten-carbide tips. Rust-resistant. Specially designed for electric hand saws. 1/2-5/8-inch round center hole. State blade size.

6 1/4-inch. Shipping weight 1 lb. 5 oz. \$8.98
6 1/2-inch. Shipping weight 1 lb. 7 oz. 8.98
7 1/2-inch. Shipping weight 1 lb. 10 oz. 9.49



CRAFTSMAN Thin-rim Blades

Last up to 5 times longer than ordinary steel blades! Impregnated with hard chrome. Just the right blades to cut cabinet and drawer pieces from veneer or plywood. Practically eliminates finish-sanding needed to remove light tooth marks... makes cuts with satin-smooth finish. Cuts leave almost invisible glue joints. Blade rim taper-ground to provide cutting clearance... teeth have practically no set. Cut to depth of 1 1/4 inches.

Thicker, heavier center acts as built-in stabilizer to reduce blade flexing and vibrations. 8-inch blade diameter. Round center hole knock-out bushed to fit either 1/2-inch or 5/8-inch arbors.

- 1 Veneer or Plywood Blade.
9 M 3253—Shipping weight 1 pound 3 ounces... \$3.98
- 2 Cabinetmaker's Blade.
9 M 3254—Shipping weight 1 pound 3 ounces... 3.98

All These CRAFTSMAN Blades are long-lasting Kromedge

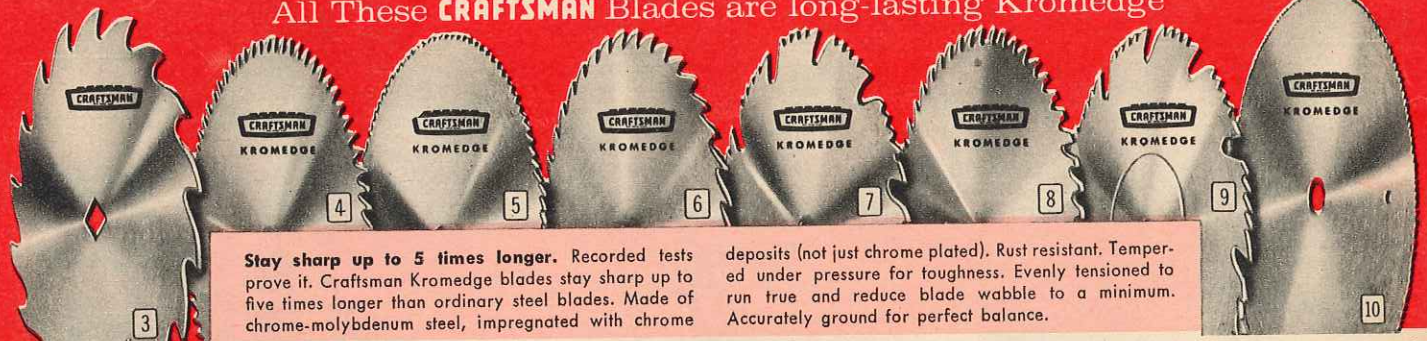

Stay sharp up to 5 times longer. Recorded tests prove it. Craftsman Kromedge blades stay sharp up to five times longer than ordinary steel blades. Made of chrome-molybdenum steel, impregnated with chrome

deposits (not just chrome plated). Rust resistant. Tempered under pressure for toughness. Evenly tensioned to run true and reduce blade wobble to a minimum. Accurately ground for perfect balance.

3 Chisel-tooth Combination Saw Blades. Bevel-filed, chisel-shaped tooth has greater hook angle. More efficient... requires less power than other blades. Crosscuts or rips.
9 M 3240—State saw blade diameter, center hole shape and diameter.

Teeth	Diam.	Center Hole	Fits these saws	Shpg. wt.	Price
30...	4 in.	*1/2-3/8-in. round..	Elec. drill saw attachments..	5 oz.	\$1.49
24...	5 in.	*1/2-3/8-in. round..	Elec. drill saw attachments..	7 oz.	1.98
24...	5 1/2 in.	1/2-in. round.....	Craftsman elec. hand saw..	10 oz.	2.29
16...	5 7/8 in.	*1 3/16-in. diamond, 1/2-in. square....	Skil-saw or Mall, Pet, former 2572...	10 oz.	2.29
16...	6 1/8 in.	1 1/8-in. round....	Black & Decker.....	10 oz.	2.29
16...	6 1/4 in.	1/2-in. square....	Pet, former 2572.....	12 oz.	2.29
16...	6 1/2 in.	*5/8-1/2-in. round..	Craftsman elec. hand saw..	12 oz.	2.29
16...	6 1/2 in.	*5/8-1/2-in. round..	Craftsman elec. hand saw..	12 oz.	2.29
18...	7 in.	*1 3/16-in. diamond, 1/2-in. square....	Skil-saw or Mall.....	14 oz.	2.49
18...	7 1/2 in.	*5/8-1/2-in. round..	Craftsman hand saw.....	14 oz.	2.49
20...	8 in.	*5/8-1/2-in. round..	Bench, elec. hand saws....	1 lb. 2 oz.	2.59
20...	8 in.	*1 3/16-in. diamond or square....	Skil-saw and Mall.....	1 lb. 2 oz.	2.59
20...	8 1/4 in.	1 1/8-in. round....	Black & Decker.....	1 lb. 2 oz.	2.59
22...	9 in.	*5/8-1/2-in. round..	9-in. bench; radial saws....	1 lb. 8 oz.	3.49
24...	10 in.	*3/4-5/8-in. round..	10-in. bench; radial saws....	1 lb. 12 oz.	3.79

†Nominal 6-in. blade may be used on 6-inch saws.

4 Nail-cutting Saw Blades. Special alloy steel harder than chrome-molybdenum steel used in other blades. Excellent flooring or lumber salvage blade. Crosscuts or rips.
9 M 3238—5/8-1/2-in. round center hole. State blade diameter wanted.
6-in. diam. Shpg. wt. 9 oz. \$4.49 8-in. diam. Shpg. wt. 1 lb. \$4.98

(5), (6) Crosscut and Rip Saw Blades. Round center hole. State catalog number, hole size and blade diameter.

Diam.	Gauge	Center Hole, in.	RPM	Shipping weight	9 M 3235 Crosscut	9 M 3236 Rip
6 in.	18	*5/8-1/2	5080 to 7640	10 oz.	\$2.29	\$2.29
7 in.	18	*5/8-1/2	4350 to 6550	13 oz.	2.49	2.49
8 in.	18	*5/8-1/2	3820 to 5730	1 lb. 2 oz.	2.59	2.59
9 in.	16	5/8	3400 to 5090	1 lb. 8 oz.	3.49	3.49
10 in.	16	*3/4-5/8	3050 to 4580	1 lb. 14 oz.	3.79	3.79

7 Flat-ground Combination Blades... use for crosscutting, ripping or mitering.
9 M 3237—State center hole size and blade diameter.

Diam.	Gauge	Center Hole	RPM	Shpg. wt.	Price
6 in.	18	*5/8-1/2 in.	5080-7640	10 oz.	\$2.29
7 in.	17	*5/8-1/2 in.	4350-6550	13 oz.	2.49
8 in.	17	*5/8-1/2 in.	3820-5730	1 lb.	2.59
9 in.	16	5/8 in.	3400-5090	1 lb. 8 oz.	3.49
10 in.	16	*3/4-5/8 in.	3050-4580	1 lb. 14 oz.	3.79
12 in.	15	*1-3/4 in.	2540-3820	3 lbs. 2 oz.	5.59

8 Cabinet Combination Blade. Professional quality. For use where the finest possible cut is desired. No jointing, no planing required. Produces almost invisible joints for cabinet making. Extremely thin gauge. Combination-type teeth leave no marks when saw rips, crosscuts or miters. Cuts with minimum of waste. Use this blade on 7-inch to 10-inch bench saws. 7-inch diameter, bushed 1/2-5/8-inch round center hole. State center hole size wanted.
9 M 3243—Shipping weight 13 ounces... \$2.59

9 Hollow Ground Combination Blades. Taper ground for smoother cutting... center of blade is dished out to provide cutting clearance. Designed for fine-finish woodworking... ripping, cross-cutting or mitering.
9 M 3239—State blade diameter and center hole size.

Diam.	Gauge Taper	Center Hole, inch	RPM	Shipping weight lb. oz.	Price
6 in.	15-18	*5/8-1/2	5080-7640	9	\$3.39
7 in.	15-18	*5/8-1/2	4350-6550	12	3.89
8 in.	15-18	*5/8-1/2	3820-5730	1	4.69
9 in.	13-16	5/8	3400-5090	1 9	7.49
10 in.	14-17	*3/4-5/8	3050-4580	1 15	8.98

10 Ply-tooth Blades. For cutting plywood and for fine finish work such as cabinet making, picture framing etc. Cut Celotex and wallboard with minimum of shredding.
9 M 3244—State blade diameter, center hole.

4-inch diameter. 1/2-inch round center hole. For 5 1/2-inch electric hand saws, 1/4-inch electric drill saw attachments and saws with 1/2-inch arbors. Shipping weight 5 ounces... \$1.49
7-inch diameter. Bushed 1/2-5/8-inch round center hole. For 7, 8, 9 and 10-inch bench saws. Also for use with electric hand saws. Shipping weight 13 ounces... \$2.59

Fine Tooth Crosscut Cutoff Blade. (Looks like Ply-tooth Blades above.) For use with electric hand saws and bench saws.

Specially engineered for cutting plywood—will not splinter end grain laminations. For Celotex, plywood, wallboard, fine-grained dry materials. Use on CRAFTSMAN 6 1/4, 6 1/2, 7 1/2 and 8-inch electric hand saws and all bench saws using blade with 1/2 or 5/8-inch round center hole. 6 1/4-inch diameter... bushed for 1/2-5/8-inch arbors.
9 M 3242—Shpg. wt. 9 oz. \$2.49

* For center-hole sizes marked with an asterisk, the center hole is knock-out bushed to fit any arbor size listed

FOR SEARS EASY TERMS see inside back cover

Make your own moldings and building trim



Mono-cutter Molding Head Set with 18 bits

20-piece set (includes head, case) **\$23.95** \$2.50 down cash

Make as many designs of trim, molding and joints as you like. No limit to the number of designs when bits used in combinations. Made especially for Sears Acra Arm Saw, but will fit any 1/2 or 3/4-inch arbor.

Bits can't turn in cutter head . . . designed to stay in perfect alignment at all times. Operates completely chatter-free, turns out trim or moldings uniform in shape and size. Sturdy plastic storage case folds into 5 1/2 x 8-inch size or hangs on wall. With wrench, spacer-washer, bushings, instructions.

9 M 3215—Shipping weight 3 pounds. . . . \$23.95



\$4.95

Head only without cutter bits

CRAFTSMAN Cutter Head. Convert your bench or radial arm saw to a jointer-planer or shaper. Save money by cutting your own moldings and trim. Use bits in combinations to make as many different designs as you can imagine. Head fits most bench or radial saws with 1/2, 3/4 or 3/8-inch round arbor, most dado or special molding inserts. With wrench, spacer washer, bushings and instructions.

9 M 3200—Cutter Head only. Made of special analysis steel, heat treated, tempered, and balanced. In plastic box with compartments for 6 bit sets. Shpg. wt. 1 lb. 6 oz. \$4.95

Cutter Bit Sets. Aligned accurately and securely on cutter head by safety lock. Made of tool steel. Blades 1 inch wide. 3 bits to the set. Shpg. wt. 4 oz. (except 9M2303).

- (2) 9 M 3211—Window Sash. \$2.79
- (3) 9 M 3212—3/8-inch Cove and Bead. 2.79
- (4) 9 M 3202—1-inch Planer and Jointer. 2.79
- (5) 9 M 2350—Cabinet Door Lip. 2.79
- (6) 9 M 2351—1/4-inch and 1/2-inch Quarter Round. 2.79
- (7) 9 M 2352—3 bead (1/4 inch). 2.79
- (8) 9 M 2354—Clover Leaf and Screen Mold. 2.79
- (9) 9 M 3210—Panel Cupboard Door. 2.79
- (10) 9 M 2355—Base Molding. 2.79
- (11) 9 M 3201—Glue Joint. 2.79
- (12) 9 M 3202—"Ogee" Window and Door Stop. 2.79
- (13) 9 M 3203—1/4-inch Flute and 1/2-inch Cove. 2.79
- (14) 9 M 3204—90° Flute. 2.79
- (15) 9 M 3205—Curved Flute and 3/16-inch Quarter Round. 2.79
- (16) 9 M 3206—1-inch Flute (1/2-inch radius). 2.79
- (17) 9 M 3207—3/16-in. Quarter Round-in. 3/16 Cove (Drop Leaf). 2.79
- (18) 9 M 3208—3/16-in., 3/8-in. Quarter Round; 1/4-in. Bead. 2.79
- (19) 9 M 3209—3/8-inch Cove. 2.79
- (20) 9 M 2303—Tongue and Groove. Includes 6 bits. Wt. 7 oz. . . . 4.95

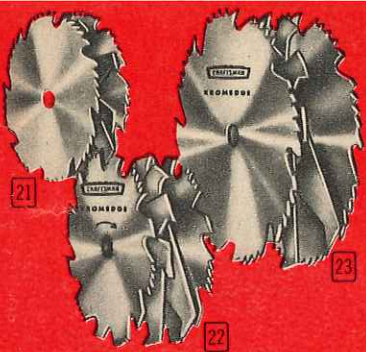
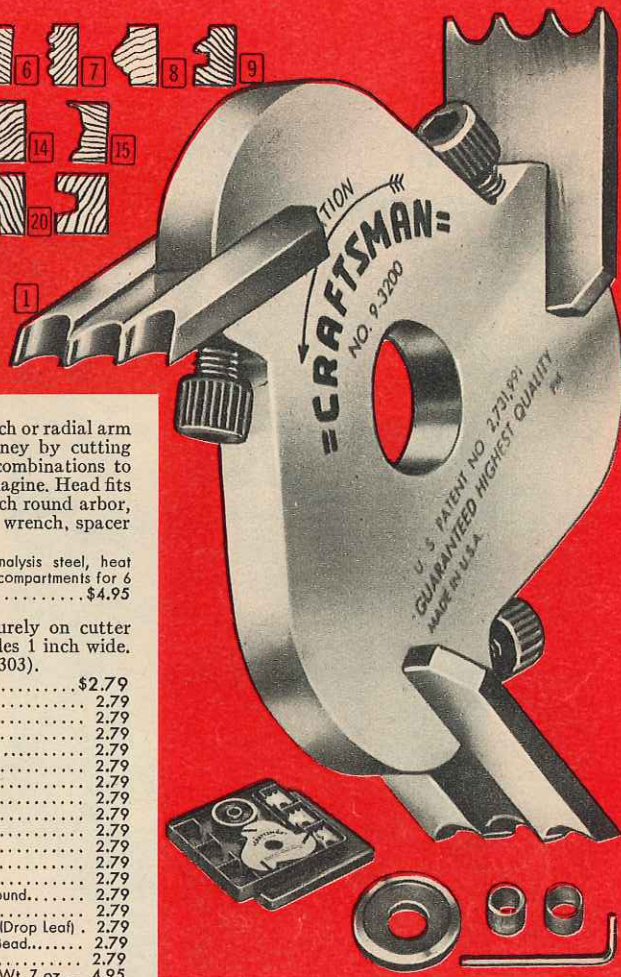

CRAFTSMAN and DUNLAP Dado Sets

[21] Dunlap 5 1/2-inch Set. Does general dado work. Made of tempered high-carbon steel. Set includes two 3/42-inch outside saws, six 1/16-inch thick chippers. Provides many extra uses for your bench saw. Shipping weight 1 pound 12 ounces.

9 M 4888—1/2-inch center hole. \$5.79
9 M 4889—3/8-inch center hole. 5.79

[22] Craftsman 6-inch Kromedge Set. For dadoing, grooving, rabbeting. Last up to 5 times longer than ordinary steel blades . . . toughened with impregnated chrome and tempered. Rust resistant. Precision-ground matched chippers. 4 of the 5 chippers 1/8 inch thick, other chipper 1/16 inch thick. Two 1/8-inch thick outside saws. Shipping weight 3 pounds 2 ounces.

9 M 3248—1/2-inch center hole. \$9.98
9 M 3249—3/8-inch center hole. 9.98

[23] CRAFTSMAN 8-inch Heavy-duty Krom-edge Set. Use this rugged set for the tougher dadoing jobs. Fits your bench, radial or swing saw. Blades last up to 5 times longer than ordinary steel blades . . . surfaces toughened with impregnated chrome deposits. With Rust-resistant finish. Set includes two 1/8-inch thick outside saws, six 1/8-inch thick chippers. Paper washers included for making 1/16-in. width adjustments. Available to fit 3/8-inch arbor or bushed for 1 to 3/4-inch center hole. *State size of center hole wanted.*

9 M 3247—Shipping weight 5 lbs. 15 oz. . . . \$16.95

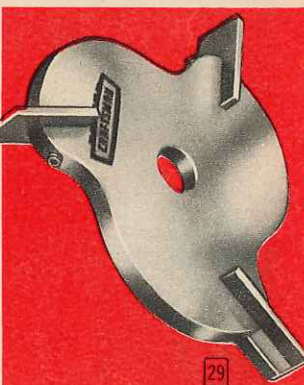
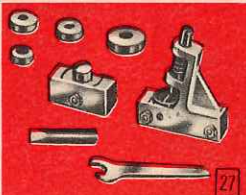

[24] Craftsman Gum and Pitch Remover. One thin coating dissolves gum and pitch from any wood-cutting blade. Cleans Karbo-Grit tools fast and easy. 8 fluid ounces per can.
9 M 4918—Shipping weight 10 ounces. 49c

[25] Circular Saw Blade Stabilizers. Stop blade wobble. . . give smoother cuts. Fit any 7 to 12-in. blade. Also used on abrasive cutoff wheels. 4-in. diam. Bushed for 3/8 to 1/2-in. center hole. *State center hole size wanted.*
9 M 4952—Shipping weight 1 lb. 2 oz. Pair. \$2.49

[26] Craftsman Saw-sharpening Vise. Holds circular saw blades firmly. Takes blades from 5 1/2 to 12-in. diam. Mounts in bench saw miter slot (up to 3/4 in.) or on work bench. Made of die-cast zinc. With steel bolt, wing nut, wrench.
9 M 3531—Shipping weight 2 pounds. \$2.98

[27] Craftsman Circular Saw Blade Setter. Sets each tooth with tap of hammer. For any 4 to 12-in. blades with 1/2, 3/4, 3/8 or 1-in. center hole. Mounts in 3/4 to 1-in. miter gauge slot. Die-cast aluminum body. With wrench, 4 bushings, 2 plungers and instructions. (Without blade).
9 M 3530—Shipping weight 15 ounces. \$2.79

[28] Craftsman Thin-steel Slicer Blade. Does job in minutes that could take hours with ordinary hand snips. For cutting corrugated or sheet roofing, black iron, guttering, furnace pipe or thin bar stock. Cuts thin steel or steel alloys up to 3/32 inch thick. Not for use on nonferrous metals such as aluminum, brass or copper.

Slices by friction; slots allow air to cool blade and pull hot metal particles away from the point of contact. Fits electric hand saws or bench saws. Blade diameter 6 1/2 in. With round center hole knock-out bushed to fit 1/2-inch to 3/8-inch arbor. Normal cutting operation generates sparks; safety goggles should be worn to protect the eyes. See index for safety goggles. With complete instructions. Shipping weight 10 ounces.
9 M 3241. \$2.98

[29] Planer Attachment. Converts saw for simple planing operations easily and at low cost. Two cutting edges on each blade. Side edge for vertical planing (maximum width of cut 1 3/4 inches). Top edge for surface planing (maximum width of cut 1 1/8 inch with one pass). 7-inch diameter. Fits tilting arbor bench saws with 1/2, 3/4 or 3/8-inch arbors.

Rugged steel alloy blades hold edge up to 5 times longer than tool steel; impregnated with chrome deposits for greater toughness. Includes cutter head, 3 blades, bushings, spacer, washer and wrench. Use with bench molding insert. Shipping weight 3 pounds.
9 M 3255. \$9.95
9 M 32552—3 Replacement Blades. Shipping weight 6 ounces. . . . \$2.98

CRAFTSMAN 10-in. Tilting-arbor Floor Model Saw

REG. U.S. PAT. OFF.

with 3 Exclusive Features

- 1 10-inch Kromedge chisel-tooth combination blade . . . sharp edge outlasts ordinary edges 3 to 5 times!
- 2 "Exact-I-Cut" saw kerf indicator . . . fast, accurate . . . lines up cut exactly . . . adjusts to blade kerf width
- 3 Lowest-priced production saw we know of in this quality range . . . truly one of America's outstanding buys!

Without motor, guard, switch, wheel set or miter gauge hold-down

\$249⁹⁵ \$10 down
cash

SPECIFICATIONS

- Depth of cut (maximum) 3 1/4 in. at 90°; 2 1/4 in. at 45°
- Blade size 10 in. with 5/8-in. center hole
- Distance in front of blade 12 1/2 in. at 3 1/4-in. depth of cut
14 1/2 in. at 1-in. depth of cut
- Dado capacity (using 6-in. dado) 1 1/4 in. deep; 1 3/8 in. wide
- Arbor tilt (maximum) 45 degrees
- Bearings 2 sealed ball; lubricated for life
- Table size: with extensions (included) 36x27 in.
without extensions 20x27 in.
- Rip fence length 31 9/16 in.; height, 2 5/8 in.
- Table height 34 5/8 in.
- Base size 22 3/4 x 19 1/4 in.
- Overall dimensions:
height 37 7/8 in.
width 36 in.
length (without motor) 38 1/2 in.; (with motor) 46 5/8 in.
- Arbor speed recommended 3450 RPM
- Motor recommended minimum 1 HP; maximum 1 1/2 HP
- Miter gauge stops three; at 90° and 45° right and left

Easy-to-reach crank controls have lock knobs to prevent slippage after cutting alignment. Pick-off fence glides on nylon strip . . . locks front and back with just one lever . . . removable from any point on table. Includes two pulleys (machine and motor), two 3/8-in. V-belts.

- 99 M 2245N—Without motor, saw guard, switch, wheel set or miter gauge hold down (see page 11). Shpg. wt. 303 lbs. \$10.00 down Cash \$249.95
- 99 M 22456N2—As above but with CRAFTSMAN 1-HP 3450 RPM capacitor motor (115-230 volt, 60 cycle AC). Shpg. wt. 349 lbs. \$10.00 down Cash \$294.00
- 9 M 2732—Saw Guard Assembly (shown on saw). Shpg. wt. 6 lbs. 6 oz. 13.95
- 9 M 2748—Wheel Set (shown on saw). Shpg. wt. 7 lbs. 6.98
- 99 M 24446L—Extra Table Extension Kit. Extends table to 52x27 in. Front and rear rip fence guide bars 52 in. long. With scale, 2 extensions (each 8x27 in.), extension scale nuts, bolts. Shpg. wt. 52 lbs. \$5.00 down Cash \$56.95
- 9 M 2961—Heavy-duty Switch (shown on saw). 1 1/2-HP double-pole type for 115-230 volt AC-DC. With mounting bracket, bolts. Shpg. wt. 2 lbs. \$7.50
- 9 M 2209—Molding Head Insert. Shpg. wt. 2 lbs. 3 oz. 4.69
- 9 M 2747—Dado Insert. 6-inch capacity. Shpg. wt. 1 lb. 2 oz. 4.69

CRAFTSMAN Swing Saw . . . just pull it through!

Without motor **\$149⁹⁵** \$5 down
cash

A fast, easy operating, heavy-duty saw. Ideal for millwork plants, shipping rooms, etc. Just pull saw through lumber—weight of swing arm returns blade. Rips, crosscuts, dados, miters, etc. Shipped by freight (rail or truck) or express from factory in Ypsilanti, Michigan.

SPECIFICATIONS:

Maximum depth of cut with 10-inch blade: 3 inches; maximum crosscut width with 10-inch blade: 16 inches; maximum ripping width (with fence) 11 7/16 inches; (without fence) 13 1/2 inches; angle range, 90° right to 90° left in 1° graduations; maximum miter cut with 10-inch blade: 3x8 3/4 inches; maximum width of miter cut: at 60°, 14 1/2 inches, at 45°, 11 1/2 in., at 22 1/2°, 6 1/2 in.; dado capacity with 6-in. dado saw, 1-in. width, 1-in. depth. Two sets of sealed precision ball-bearings.

Table size, 11 5/8 x 24 inches; base size, 24 x 18 1/8 in.; column diameter, 2 3/4 inches; arbor speed recommended, 3450 RPM; minimum motor recommended, 3/4 HP at 3450 RPM; size of machine and motor pulleys (included), 3-inch diameter with 5/8-inch bore; size V-belt (included), 1/2 x 38 inches.

Overall dimensions: height 41 3/4 inches, depth 26 1/2 inches, width 24 inches; size and type of blade (included), V-tooth crosscut with 10-inch diameter, 3/4-inch bore.

F99 M 2545N—Without motor. Shipping weight 201 pounds. \$149.95

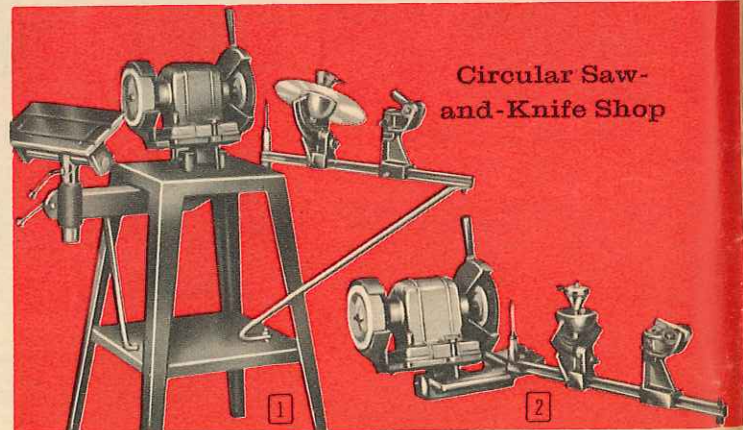
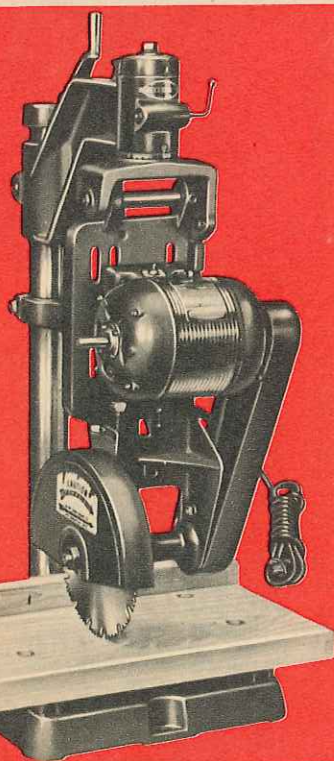

Saw and Knife Shop **\$189⁰⁰** \$5 down
cash

Gummer and Saw Setting Attachment **\$127⁵⁰** \$5 down
cash

1 Here's an easy way to add extra income in your spare time or even start a full-time business. Prospects all over your town or city want knives, saws, lawn and garden tools sharpened. No previous experience needed to operate. You'll be surprised how quickly you become expert with your Saw-Knife Shop. Easy to set up, too. Mounts on any work bench in your basement, garage or workshop. Includes Gummer and Saw Setting Attachment (2) at right, knife grinding attachment and instructions. Bench not included. See Shipping Notice at right.

F99 M 1390N—Saw-and-Knife Shop. Shipping weight 145 pounds. \$189.00
F99 M 1391N—Tool Bench for above. Shipping weight 50 pounds. 24.50

2 Gummer and Saw Setting Attachment. Joints, grinds, forms and sets teeth on saws 4 to 48 inches in diameter with 1/2 to 2-inch center holes. Grinds straight or bevels teeth right or left from 0° to 45°. 1/4-HP 3450 RPM split-phase ball-bearing motor (110-120-volt, 60-cycle AC). 1/2-inch threaded double end motor shaft. 8-foot cord. 8 x 3/16-inch gumming wheel included. With instructions. Shpg. wt. 95 lbs. See Shipping Notice below.

F99 M 1392N \$127.50

SHIPPING NOTICE: Items (1) and (2) above shipped by freight (rail or truck) or express from factory near Kansas City, Missouri.

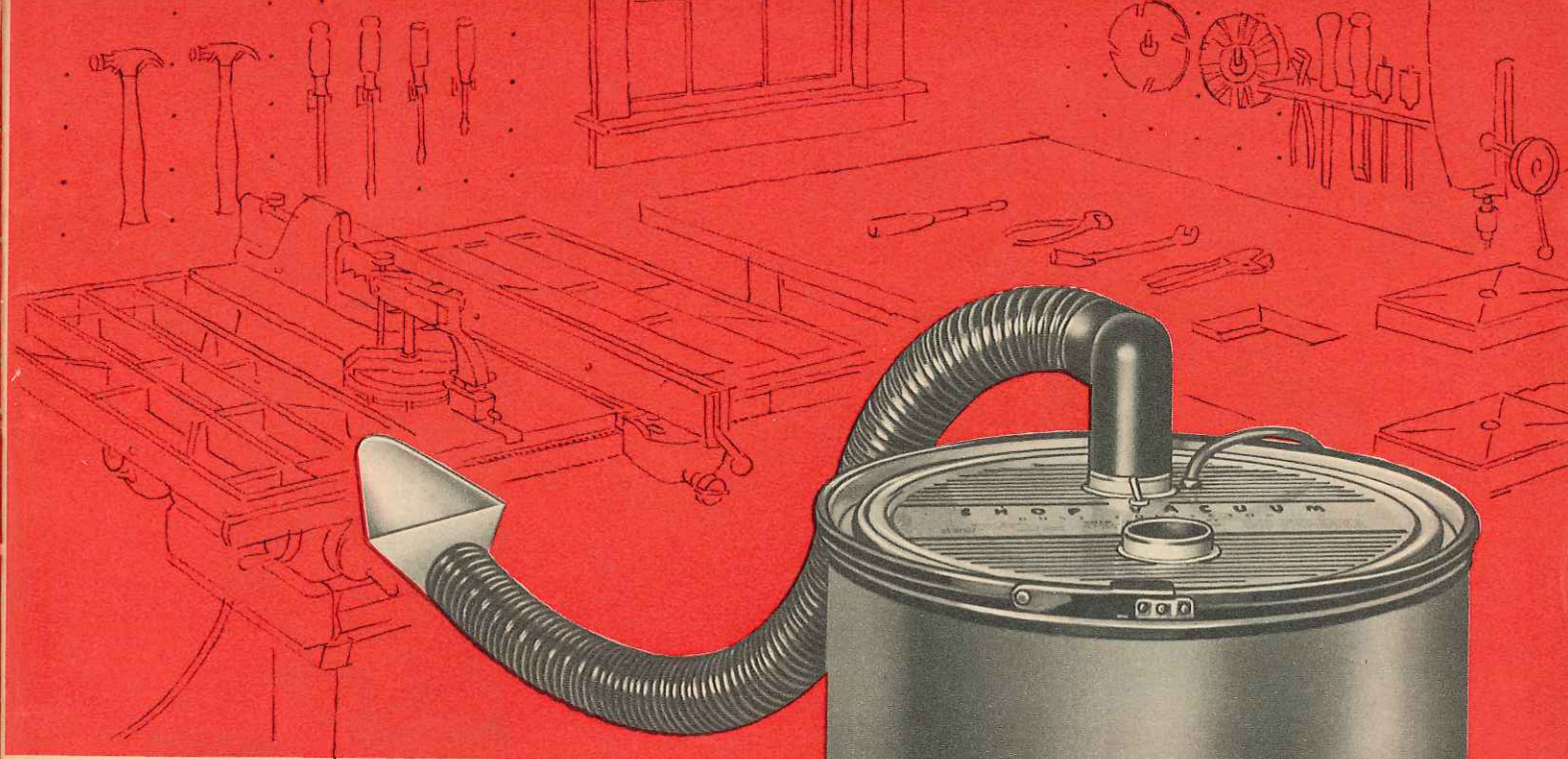

Shop Vacuum

For all heavy-duty cleaning chores

Without dolly **\$39.95** \$4 down
cash

- Use it to clean basement, chimney flue, attic, garage, gutters . . . does those tough cleaning jobs fast and easy.
- Perfect for barber shops, gas stations, stores and industrial plants . . . a heavy-duty all-purpose cleaner. Fine for cleaning up sawdust.
- Powerful suction draws waste directly into 28-gal. fiber drum . . . no sweeping. Guaranteed against defects for one year!

Now you can squeeze hours of cleaning chores into just minutes! Powerful suction from ½-HP motor does all the work . . . you simply direct the cleaning head. Encourages clean, orderly areas . . . you'll even want to get those dirty spots once thought too difficult. No bags to bother with . . . just let fiber drum fill up, then empty directly into trash can . . . saves valuable time and work, too. Swivel top rotates 360° for easy handling. Triangular-shaped nozzle gets into corners.

Vacuum hose adapter allows use of any household vacuum hose or attachment. Also with 6-foot, 2½-inch diameter flexible hose, Power Bronze fiber drum, enclosed ½-HP ball-bearing two-stage motor (110-120-volt, 25-60-cycle AC-DC), cord, plug and switch. *UL approved.* Extra attachments available (not included, see below) are: a nozzle kit which consists of a blower nozzle and a round brush attachment. Add the 2-piece aluminum extension handle and you can reach 46 inches further. Four-wheel dolly is easy-rolling, won't tip over.

Drum dimensions without dolly: 19-inch diameter, 27-inch height.

- 99 M 1696N—Shpg. wt. 28 lbs. Shipped freight (rail or truck) or express. \$39.95
- 9 M 16908—Four-wheel Dolly. Shipping weight 3 lbs. 6 oz. 3.98
- 9 M 16909—Nozzle Kit. One round brush nozzle, one blower nozzle, Shpg. wt. 12 oz. . . . 2.49
- 9 M 16905—Flexible Hood Kit. With four magnetic clips for attaching under bench saw . . . cuts clean-up time. Shpg. wt. 1 lb. 8 oz. \$2.98
- 9 M 16962—Two piece 46-inch Extension Handle. Aluminum tubing, Shpg. wt. 2 lbs. 2 oz. . . 3.98
- 9 M 16963—6-ft. Extension Suction Hose with Connector. Shipping weight 1 lb. 4 oz. . . . 4.98
- 9 M 16906—Replacement Paper Air Filter Bag. Shpg. wt. 3 oz. Package of six 98c
- 9 M 16907—Replacement Cloth Air Filter Bag. Shpg. wt. 3 oz. Each 98c



Gets hard-to-clean-up materials



Cleans car trunk . . . picks up dirt, stones, etc.



Fiber drum is easy to empty when full

EASY TERMS . . . only \$4 down . . . See inside back cover for details



\$52.50
cash

\$5 down

without motor,
belt guard
or stand

SPECIFICATIONS

	4 1/8-inch model	4 3/8-inch model
Width of cut.....	4 1/8-inch	4 3/8-inch
Depth of cut.....	3/8-inch	3/8-inch
Rabbit depth.....	3/8-inch	3/8-inch
Fence length.....	19 1/8-inch	26-inch
Spindle diameter.....	1/2-inch	1/2-inch
Front table (in.).....	11 3/4 x 6 3/8	17 3/4 x 8 3/4
Rear table (in.).....	11 1/8 x 6 3/8	15 1/4 x 5 1/8
Cutter knives.....	Two	Three
Bearings.....	2 self-lubricating sleeve	2 sets sealed, precision ball
Motor recommended.....	1/2-HP, 1725 RPM	1/2-HP, 1725 RPM
Pulleys:		
Machine (included).....	2-inch	2-inch
Motor (not included).....	5-inch	5-inch
Recommended arbor RPM.....	4500	4500



\$82.50
cash

\$5 down

without motor,
belt guard
or stand

CRAFTSMAN 4 1/8-inch Jointer-Planer

Sturdier than any other we know of at this price

Cast semi-steel base. Cast semi-steel tables, 3-point suspension mounting; front table adjustable. Removable spring-loaded guard. Solid steel cutter head with two 4 1/8-inch blades. Fence tilts up to 45° either way. Mounting dimensions: 7 1/4 x 21 1/4 in. Overall dimensions: 8 3/8 in. high; 9 3/4 in. wide; 29 7/16 in. long.

- 99 M 2186L—Without motor, motor pulley, V-belt, belt guard, stand. Shpg. wt. 60 lbs. . . . \$52.50
- 99 M 21865L2—With 1/2-HP 1725 RPM sleeve-bearing motor 110-120-volt, 60-cycle AC, 5-inch motor pulley, 1/2 x 54-inch V-belt. Shpg. wt. 86 lbs. \$5.00 down. . . . Cash \$68.50
- 9 M 21867—Two extra Blades for above. Shipping weight 4 ounces. . . . 1.69
- 99 M 2959L—Tool Stand for above. Cast iron base. Shpg. wt. 54 lbs. \$2.50 down. . . . Cash 24.50
- 9 M 2907—Belt Guard for above stand. Shpg. wt. 4 lbs. 4 oz. . . . 5.69

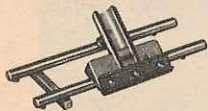

Blade Sharpener Attachment for bench saws. Sharpens jointer-planer knives up to 6 3/8 inches long. Use attachment with 6 x 1/2-inch grinding wheel. Fits all Sears bench saws. Grinding wheel not included.

9 M 2658—Shipping weight 8 pounds. . . . \$12.50

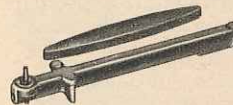

Knife Setting Gauge. Machined cast iron . . . micrometer adjustments. Accurately lines up blades after sharpening. Special abrasive stone included for touching up blades after installation.

9 M 2647—Shipping weight 1 lb. 10 oz. . . . \$7.49

CRAFTSMAN 4 3/8-inch Jointer-Planer

Features Micro-adjustment and extra large working surface

Micro-adjustment aligns three 4 3/8-in. blades in cutter head. 30-in. working surface . . . largest 4-in. Jointer-Planer we know of! Locking device holds front table setting. Cast semi-steel tables. Removable spring-loaded guard. Mounting dimensions: 5 5/8 x 25 1/4 inches. Overall dimensions: 8 7/16 x 14 3/8 x 31 3/8 inches.

- 99 M 2067N—Without motor, motor pulley, V-belt, belt guard, stand. Shpg. wt. 80 lbs. . . . \$82.50
- 99 M 20675N2—With 1/2-HP 1725 RPM sleeve-bearing motor (110-120-volt, 60-cycle AC), 5-inch motor pulley, 1/2 x 43-inch V-belt. Shpg. wt. 106 lbs. \$5.00 down. . . . Cash \$98.95
- 9 M 2291—Three extra Blades for above and former model 103.21820. Shpg. wt. 7 oz. . . . 4.49
- 99 M 20687L—Tool Stand for above. Cast iron base. 30 in. high. Shpg. wt. 55 lbs. . . . 26.95
- 9 M 29115—Belt Guard for above stand. Shpg. wt. 4 lbs. 5 oz. . . . 5.29

CRAFTSMAN Planer-Molder

For heavy production use

Combines a 12 1/4-in. Thickness Planer with a 6-in. Molder. Planes lumber up to 12 1/4 in. wide, 6 in. thick . . . as short as 7 in., thin as 3/16 in. Ball-bearing 3 1/2-in. cutter head has 3 knives. Cutter head takes bits (not included) for molding faces and edges of boards up to 6 in. wide. Power feeds at rate of 12 or 22 ft. per minute. 42-in. bed. Roller chain power feed and elevating mechanisms. Use 1 to 5 HP for 4000 RPM cutter head speed. Machine pulley included. All items below from factory near Kansas City, Mo. "N" items shipped freight (rail or truck) or express. Less motor, stand. F99 M 2339N—Wt. 260 lbs. \$10 down. . . . Cash \$255.00

Thickness Planer without molding features. 12 1/4 x 6-inch capacity; 18-inch bed. F99 M 23394N—Wt. 235 lbs. \$10 down. . . . Cash \$229.50

Welded Steel Stand for either of above. 22 1/2-in. square top; 24 3/4-in. square bottom. 20 1/2 in. high. F99 M 23395N—Shipping weight 32 pounds. . . . \$27.50

Molding Cutter Bits. For F99 M 2339N above. Choice of 12 patterns: rabbet . . . tongue . . . groove . . . 1/2 and 1/4-in. quarter round . . . 3-bead . . . clover-leaf . . . glue joint . . . window and door stop . . . 90° flute . . . 1-in. and 1/2-in. radius flute . . . 5/16-in. quarter round and cove . . . 3/16 and 3/8-in. quarter round. Set of 3 bits for each pattern. F9 M 23396—Wt. 3 oz. Specify pattern. Each pattern \$2.89

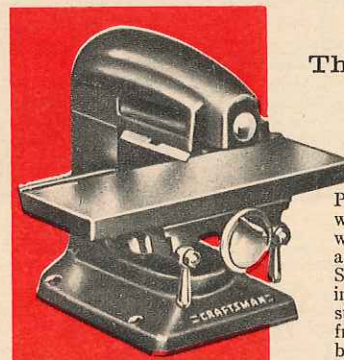

CRAFTSMAN Thickness Planer

Planes stock up to 6 in. wide in one pass. Handles wood to 2 in. thick . . . thin as 1/8 in., short as 4 in. Sealed ball bearings. 2 5/8-in. steel cutter head, 3 alloy steel knives. Cast iron frame, table. Anti-kick-back guards.

\$84.95
cash

Only \$5 down

Double lock holds depth when making duplicate cuts. Chip breaker and pressure bar guard held. Wheel depth-of-cut adjustment; depth indicator. Overall height 15 1/2 inches. Machine pulley supplied. Use at least 1/2-HP 3450 RPM motor with 2 1/2-inch motor pulley for 4200 RPM. **Motor, motor pulley, V-belt not included.** (With this tool you can plane boards to any desired thickness . . . finish rough sawed lumber . . . reclaim old boards, etc.) 99 M 2370N—Shipping weight 81 pounds. \$5.00 down. . . . Cash \$84.95

99 M 23705N2—With 1/2-HP 3450 RPM capacitor motor (110-120-volt, 60-cycle AC), motor pulley, V-belt. Wt. 111 lbs. \$5.00 down. . . . Cash 114.95

Three extra Blades for above Thickness Planers. 9 M 2293—Shipping weight 10 ounces. . . . 5.49

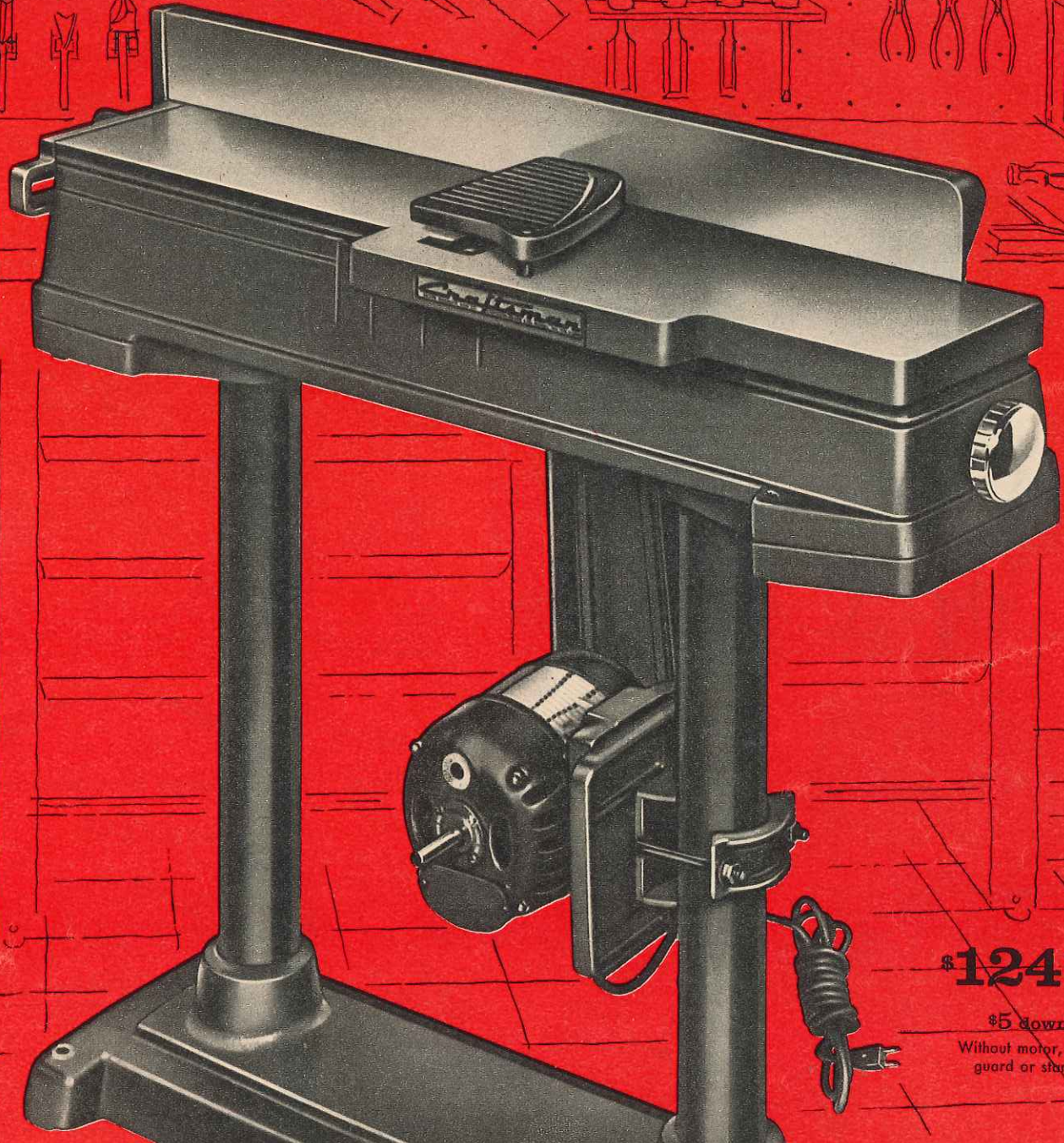

\$124.95
cash

\$5 down
Without motor, belt guard or stand

SPECIFICATIONS

- Width of cut.....6 1/8 inches
- Depth of cut.....1/2 inch
- Size, front table.....16 3/8x7 7/8 inches
- Size, rear table.....17 5/16x7 inches
- Rabbet depth.....1 1/2 inch
- Bearings....2 sets sealed precision ball
- Cutter knives.....3 alloy steel, each measuring 6 1/8x1 1/4x1 1/8 inches
- Recommended arbor speed... approximately 4500 revolutions per minute
- Motor recommended (minimum).....1/2 horsepower, 3450 revolutions per minute
- Machine pulley (included)....2 inches
- Motor pulley (not included).2 1/2 inches
- Mounting dimensions.9 1/2x31 1/16 inches
- Overall dimensions:
 Height.....9 1/4 inches
 Width.....20 5/8 inches
 Length.....42 1/4 inches

New CRAFTSMAN

REG. U. S. PAT. OFF.

6 1/8-inch Heavy-duty Jointer-Planer

- **Finest we've ever sold . . . designed for continuous heavy-duty service**
- **You get Micro-adjustment PLUS these 7 important . . . new features**

1. Base, rear table and feet are cast in *one* piece for extra rigidity
2. Fence is always in contact with rear table for greater accuracy and safety
3. Fence has adjustable stops at 90° and 45°—the two most commonly used angles
4. Fence extends over entire length of rear table for more rigidity and accuracy
5. Double-lead screws permit you to raise and lower front table *twice as fast*
6. Bearing housings are part of base casting for more accurate blade alignment
7. New-type spring-loaded guard swings back quickly after each pass

Rabbets 1/2-inch cut with one pass! Massive cast semi-steel base. Micro-adjustment aligns three 6 1/8-inch wide blades set in solid steel cutter head.
 99 M 2061N—Without motor, motor pulley, V-belt, belt guard or stand. Shipping weight 120 pounds. \$5.00 down.....Cash \$124.95
 99 M 20615N2—With 1/2-HP 3450 RPM capacitor motor (110-120-volt, 60-cycle AC), 2 1/2-inch motor pulley, 1/2x45-inch V-belt. Shipping weight 150 pounds. \$5.00 down.....Cash \$154.95

9 M 2293—3 extra Blades. For Jointer-Planer above. Shipping weight 10 ounces.....\$5.49
 99 M 29402N—Tool Stand. 12x31 1/4-inch cast iron base. 31 inches high. Shipping weight 77 pounds.....\$34.95
 9 M 2819—4 Ball-bearing Casters for above stand. With hex socket wrench. Shipping weight 1 pound.....\$4.69
 9 M 29082—Belt Guard. Covers belt and pulley to protect operator. Shipping weight 4 lbs. 8 oz.....\$6.98

Buy your Power Tools on Sears Special Easy Terms . . see inside back cover



ONLY
\$64⁵⁰ cash
 \$5 down

CRAFTSMAN 12-inch REG. U. S. PAT. OFF. 3-wheel Band Saw

Tests prove the exceptional strength, accuracy and durability of this fine saw

Cut over 25 MILES of 1-inch yellow pine—ran continuously for more than 500 HOURS—all without showing any signs of fatigue. Extremely accurate—cuts as thin as 20/1000 of an inch. "Super-alloy" blade result of years of testing. (Not recommended for cutting metal.)

We believe this 3-wheel band saw is the greatest value of its type on the market. CRAFTSMAN design gives this saw a full 12-inch throat—without the great height necessary for the same size throat in a conventional 2-wheel band saw. Ideal for home craftsmen, woodworking and wood pattern shops.

Cuts to center of 24-inch board, up to 4 inches thick. Tensioning knob locks against stop. Double row ball bearings integral with shaft. Porous iron bearings on idler wheels. All working parts enclosed. 20¹/₁₆ inches high. 12x12-inch table tilts 0 to 45°; has indicator. 62x¹/₄-inch blade; 4-inch machine pulley. Takes ¹/₄-inch or ³/₈-inch blade. Shipped freight (rail or truck) or express.

Specifications: Depth of throat, 12 inches; capacity of cut (maximum), 4 inches; table size, 12x12 inches; width of blade, ¹/₄ or ³/₈ inches; length of blade, 62 inches; bearings, drive shaft: double row, lubricated for life; motor pulley (not included), 3 inches; machine pulley (included), 4 inches; motor recommended (minimum) ¹/₂ HP, 1725 RPM; overall dimensions: Height 20¹/₁₆ inches; width 12 inches; depth 28¹/₁₆ inches.

99 M 2455L—Without motor, motor pulley, V-belt. Shpg. wt. 66 lbs. \$64.50
 99 M 24556N2—With CRAFTSMAN ¹/₂-HP 1725 RPM split phase motor for 110-120 volt, 60-cycle AC; 3-inch motor pulley; V-belt. Shipping weight 91 pounds. \$5.00 down, \$5.00 monthly. Cash \$79.50
 9 M 2664—Extra Blades for above Band Saw. 62 in. long. ¹/₄ or ³/₈ in. wide. State width. Shipping weight 4 ounces. \$1.39

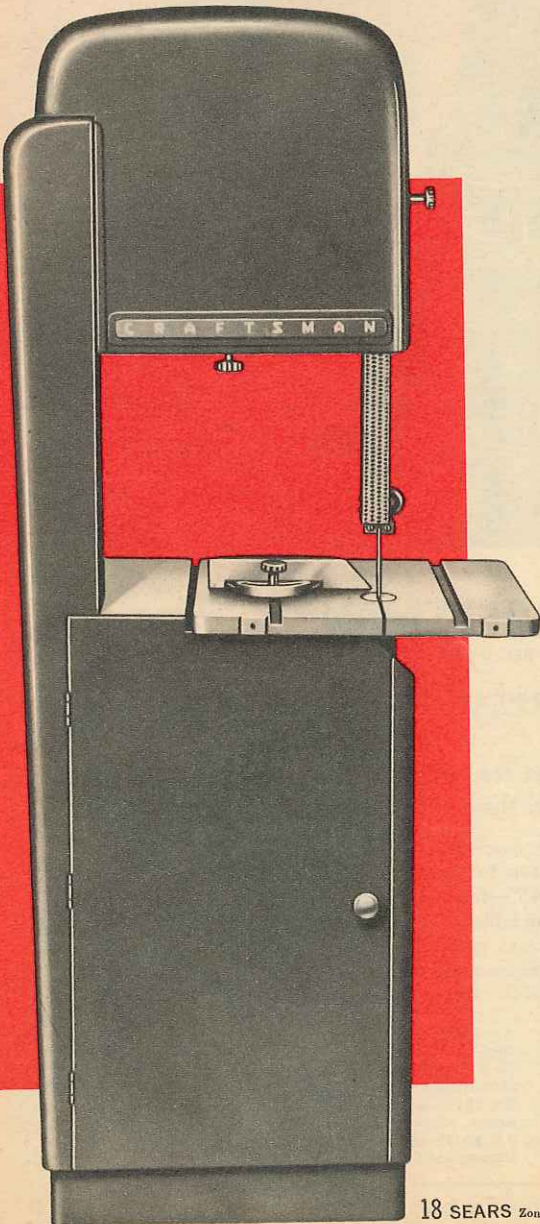

CRAFTSMAN 18-inch REG. U. S. PAT. OFF. Industrial Band Saw

Cuts wood up to 12¹/₂ inches thick

\$395⁰⁰ \$10 down
cash

SPECIFICATIONS

- Depth of throat..... 18 inches
- Capacity of cut (maximum)..... 12¹/₂ inches
- Table size..... 20¹/₈x17³/₈ inches
- Length of blade..... 11 feet
- Width of blade..... ¹/₄ to 1 inch
- Bearings..... Six sets of grease-sealed precision ball... never need lubrication
- Size of each wheel..... 18 inches
- Machine pulley (included)..... 7-inch single-groove V
- Motor pulley (included)..... 3-inch single-groove V
- Motor recommended (minimum)..... 1 HP 1725 RPM. (Not included.)
- Overall dimensions: Height 6 feet 3 inches; width 22¹/₂ inches; depth 31 inches
- Blades... Two 11-foot (¹/₄-inch metal cutting and ³/₈-inch wood cutting)

2 Wheels. Built-in ball-bearing gear reduction assembly permits blade speeds of 118 ft./min. for heavy steel; 167 ft./min. for med. cuts; 221 ft./min. for lighter gauge steel; 3550 ft./min. for wood.

Cuts to center of 36-in. circle in wood 12¹/₂ in. thick. Steel frame. Table tilts 0 to 45°; locks; 2 miter gauge slots. Miter gauge, saw guides. 2 rubber-tired cast-iron wheels. Freight (rail or truck) or express from Cincinnati, Ohio factory.

F99 M 2358N—Wt. 494 lbs. \$19.00 monthly. Cash \$395.00
 F99 M 23585N—As above, but without gear reduction unit. One 132x³/₈-in. wood cutting blade only. Motor pulley, V-belt not included. Shpg. wt. 460 lbs. \$10.00 down, \$15.00 monthly. Cash \$325.00

F99 M 23586—Rip Fence for band saws above. Shpg. wt. 13 lbs. From factory in Cincinnati, Ohio. \$22.50

F9 M 2752—Metal Cutting Blades. 11 ft. long. ¹/₄, ³/₈, ¹/₂, or ³/₄ in. wide. Shipping weight 1 lb. ea. From factory in Chicago, Ill. State width. Each \$3.98

F9 M 2715—Wood Cutting Blades. 11 ft. long. ¹/₄, ³/₈ or ¹/₂ in. wide. Shipping weight 1 lb. each. From factory in Chicago, Ill. State width. Each \$2.49

Band Saw Blades

As low as **\$1²⁹**

These fine CRAFTSMAN blades made from best quality Swedish saw steel. Each blade properly set, filed and precision ground. Blades for cutting in wood, brass, non-ferrous metals, steel. Lengths from 56¹/₂ to 80 inches; widths from ¹/₈ to ¹/₂ inch. Special lengths available for cutting wood. Each blade examined before shipment. Order several. State width. Shipping weight each 8 ounces.

9 M 2660—For wood. 56¹/₂ inches long; width ¹/₈ or ¹/₄ inch. \$1.29

9 M 2336—For wood. Skip tooth. 58 inches long; width ¹/₈, ¹/₄, or ³/₈ inch. \$1.29

9 M 2664—For wood. For Band Saw 99M2455L (above, left). With skip tooth. 62 inches long. Width ¹/₄ or ³/₈ inch. \$1.39

9 M 2665—For wood. 63 inches long; width ¹/₈, ¹/₄, or ³/₈ inch. \$1.29

9 M 2657—For wood. 78 inches long; width ¹/₈, ¹/₄, ³/₈ or ¹/₂ inch. \$1.29

9 M 2623—For wood. Especially for CRAFTSMAN Band Saw 99 M 2425L (on facing page). 80 in. long. ¹/₈, ¹/₄, ³/₈, ¹/₂ in. wide. \$1.29

9 M 2668—For brass and non-ferrous metals. 78 inches long; width ¹/₄ inch. \$1.39

9 M 2624—For brass, non-ferrous metals. For CRAFTSMAN Band Saw 99 M 2425L (on facing page). 80 inches long. Width ¹/₄ inch. \$1.39

9 M 2625—For use on steel. For Band Saw 99 M 2425L (on facing page). 80 inches long; width ¹/₄ inch. \$2.98

Special Length Band Saw Blades. For wood. (Not for 3-wheel band saws.) Not endless. For blades made endless add 60¢ each to prices below.

F9 M 2669—State length, width and whether you want blades made endless. From Chicago, Ill. factory.

Width inches	Wt. per foot	Per foot	Width inches	Wt. per foot	Per foot
¹ / ₈ ...	3 oz.	19c	³ / ₈ ...	3 oz.	..27c
¹ / ₄ ...	3 oz.	19c	¹ / ₂ ...	3 oz.	..29c
³ / ₈ ...	3 oz.	19c	1 1/4...	5 oz.	..35c
¹ / ₂ ...	3 oz.	25c	1 1/2...	5 oz.	..45c

CRAFTSMAN 2-wheel 12-inch

REG. U.S. PAT. OFF.

Ball-bearing Band Saw

Cuts wood up to 6 inches thick!
Extra-safe . . . all working parts enclosed

ONLY \$99⁵⁰ \$5 down
cash without motor,
guard or stand

SPECIFICATIONS

- Depth of throat 12 inches
- Capacity of cut (maximum) 6 inches
- Table size 12 $\frac{1}{2}$ x14 $\frac{1}{4}$ inches
- Length of blade 80 inches
- Width of blade Takes $\frac{1}{8}$ to $\frac{1}{2}$ inch width
- Blade speed Travels 2165 feet per minute
- Bearings Includes four sets of precision ball bearings, lubricated for life
- Machine pulley (included) 5-inch
- Motor pulley (not included) 2-inch
- Motor recommended (minimum power) $\frac{1}{2}$ HP at 1750 RPM
- Overall dimensions of band saw (without stand):
Height 34 $\frac{1}{2}$ inches; width 14 $\frac{1}{16}$ inches;
length 22 $\frac{3}{8}$ inches.

This rugged, versatile band saw will cut to the center of a 24-inch circle in wood up to 6 inches thick. Strong, heavy-duty construction; designed and built for production work and continuous operation. We believe no other band saw in this price range has these features:

- (1) "Unicast" cover and frame for extra strength and rigidity.
- (2) Self-aligning upper blade guide reduces friction, prolongs blade life.
- (3) All working parts completely enclosed . . . if blade ever breaks it's in housing where it can't fly out and injure someone.
- (4) Oil-impregnated bronze blocks, ball-bearing thrust wheels on saw guides above and below table.
- (5) Integral drive shaft and ball-bearing unit.

Comes with one 80x $\frac{1}{4}$ -inch blade (for extra blades see facing page). Big 14 $\frac{1}{2}$ x12 $\frac{1}{4}$ -inch table tilts 0 to 45°; has miter slot. Two 12 $\frac{5}{8}$ -inch cast-iron rubber-tired wheels. Four sets of ball bearings, lubricated for the life of the saw.

Motor recommended is $\frac{1}{2}$ HP, 1750 RPM. Use 2-inch motor pulley. For miter gauge see 9 M 2760 below. For rip fence see 9 M 23432 listed below (right).

For cuts in brass, non-ferrous metals and steel, use Slo-Speed Converter listed below (left). Makes your band saw even more useful and versatile. Cuts blade speed to 200 feet per minute.

Guaranteed against defects in materials and workmanship.

- 99 M 2425L—Without motor, pulley, guard, stand. Shipping weight 66 pounds. . \$99.50
- 99 M 24256L2—With CRAFTSMAN $\frac{1}{2}$ -HP 1750 RPM motor (110-120 volt, 60 cycle AC), pulley, V-belt. Shipping weight 91 pounds. \$5.00 down. Cash \$112.50
- 99 M 2957L—Steel Tool Stand, Base 12x20 $\frac{1}{2}$ x5 inches; tapped $\frac{1}{2}$ x13 threads for casters below. 2 $\frac{3}{4}$ -in. column; 26 in. high. Shpg. wt. 51 lbs. \$3.00 down. Cash \$26.95
- 9 M 2819—4 Casters for Stand. $\frac{1}{2}$ x13 threads. Shipping weight 1 lb. 4.69
- 9 M 2907—Belt Guard. Shipping weight 4 lbs. 4 oz. 5.69
- 9 M 2760—Miter Gauge (not shown). Shipping weight 5 lbs. 2 oz. 9.95

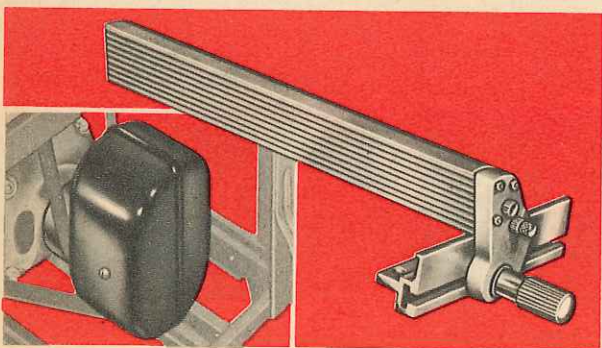

Slo-Speed Converter

Especially for 10 to 14-inch band saws, with 1750 RPM motors, $\frac{1}{2}$ or $\frac{3}{4}$ HP, with $\frac{1}{2}$ or $\frac{5}{8}$ -inch motor shafts. Cuts blade speed at 10:1 ratio. Lets you cut steel, brass and other non-ferrous metals without damaging your band saw. Wt. 6 lbs.
9 M 2342—\$3.50 down. Cash \$33.50

Rip Fence for Band Saw

Lets you rip planks and boards evenly at predetermined width. Fits Band Saw 99 M 2425L above. For best results use $\frac{1}{2}$ -inch blade. Locks at front and rear, won't slip when in use. Fittings are included. Add to your easy terms order.
9 M 23432—Shpg. wt. 4 lbs. . \$9.50

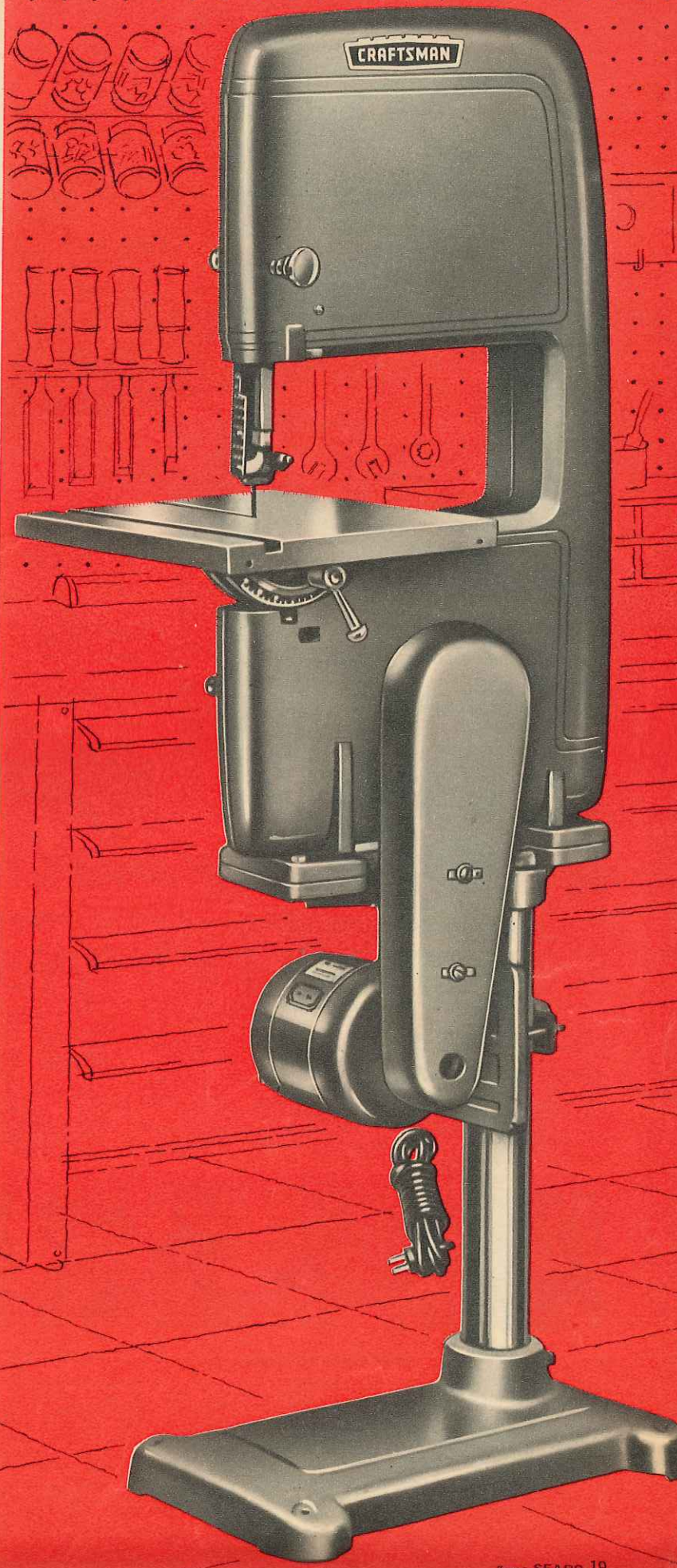

Buy your Power Tools and power tool accessories on Sears Easy Terms.
See inside back cover for details

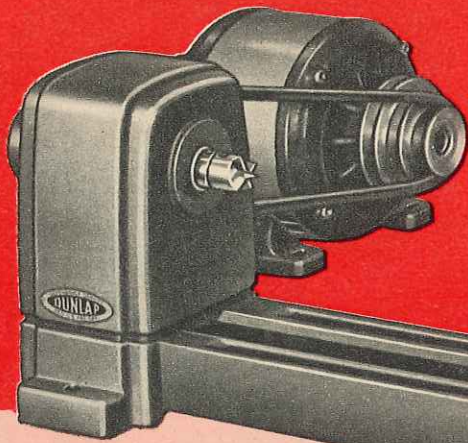

Without motor, motor pulley or V-belt

\$34⁵⁰ cash **\$3.50** down

SPECIFICATIONS

- Swing over bed.....8 inches
- Distance between centers.....24 inches
- Length of bed.....36 $\frac{3}{4}$ inches
- Headstock spindle: straight, flat, unthreaded
- Spindle speeds: 1025, 1750, 2985 RPM
- Bearings: 2 porous bronze, 1 thrust ball
- Tailstock spindle: straight, unthreaded
- Tailstock ram travel.....1 $\frac{1}{2}$ inches
- Machine pulley (included) 3-in. 3-step
- Motor pulley (not included with lathe) 3-inch 3-step
- Motor size recommended (minimum): $\frac{1}{8}$ to $\frac{1}{2}$ horsepower, 1725 RPM
- Mounting dimensions: 33 $\frac{3}{4}$ x6 inches between hole centers
- Overall dimensions: height 8 $\frac{3}{8}$ inches; width 7 to 8 inches; length 40 inches

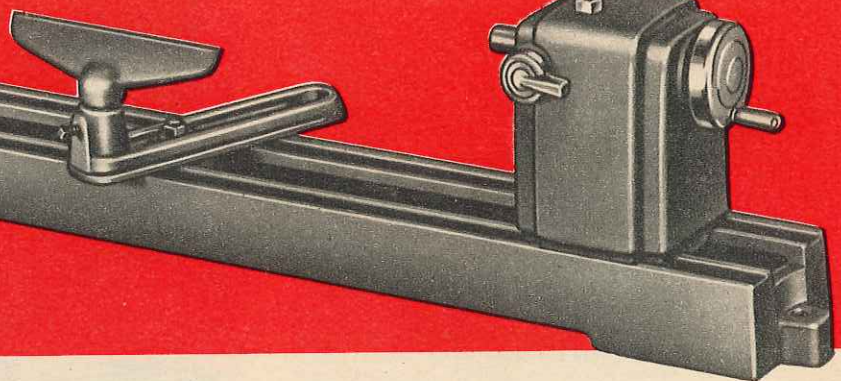

DUNLAP Economy Wood Lathe

8-inch swing; 24 inches between centers; 36 $\frac{3}{4}$ -inch bed. A rugged, well-made tool ideal for home or shop. $\frac{5}{8}$ -inch straight unthreaded spindle in headstock and tailstock. 2 self-lubricating porous bronze bearings and 1 ball thrust bearing in headstock. 3-point mounting assures accuracy, reduces twist and strain. Bronze finish. 40 inches long overall. Comes complete with wrench, tool rest, spur and cup centers.

99 M 2160L—Without motor, motor pulley or V-belt. Shipping weight 45 pounds. \$3.50 down, \$5.00 monthly.....Cash \$34.50
 99 M 21605L2—With CRAFTSMAN $\frac{1}{2}$ HP 1725 RPM split-phase motor (110-120-volt, 60-cycle AC); $\frac{1}{2}$ x36-inch V-belt; 3-inch 3-step motor pulley. Shpg. wt. 71 lbs. \$5.00 down, \$5.00 monthly.....Cash \$49.95

Wood Lathe Manual. Contains 32 pages with 230 illustrations. Describes over 150 lathe operations.
 9 M 2920—Shipping weight 2 ounces.....29c

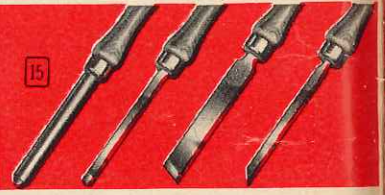
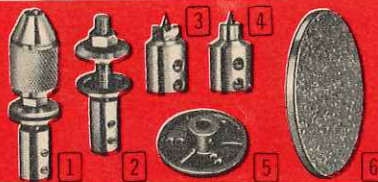

Drill, sand, turn wood with these Lathe Accessories

- 1 Work Arbor with 3-jaw, $\frac{1}{2}$ -inch Drill Chuck, Chuck and $\frac{1}{2}$ -inch x 20-thread arbor. Fits lathes or motor shafts with $\frac{1}{2}$ -inch or $\frac{5}{8}$ -inch unthreaded straight spindle. 2 setscrews. State $\frac{1}{2}$ or $\frac{5}{8}$ -in. bore. 9 M 2151—Wt. 1 lb. 10 oz.....\$2.29
- 2 CRAFTSMAN General-Purpose Work Arbor. Carbon steel. 4 $\frac{1}{2}$ inches long. 3 $\frac{1}{8}$ -inch spindle with $\frac{1}{2}$ -in.x20 thread. Steel flanges. 2 setscrews. State whether for $\frac{1}{2}$ or $\frac{5}{8}$ -in. spindle. 9 M 2164—Shpg. wt. 12 oz.....\$1.39
- 3 (3)-(4) Lathe Centers. For any lathe with $\frac{5}{8}$ -in. straight spindle. 9 M 2105—Headstock Spur Center. Shipping wt. 6 oz.....\$1.19
- 4 9 M 2102—Tailstock Cup Center. Shipping wt. 6 oz..... 1.19
- 5 Face Plate. Cast iron. For lathes with $\frac{5}{8}$ -in. straight unthreaded spindle. 4-in. diameter. With setscrew. 9 M 2320—Wt. 1 lb. 7 oz..... \$2.79
- 6 Sanding Plate. Cast iron. Fitted with sandpaper disc. 9 M 2341—8-in. diameter. For lathes with $\frac{5}{8}$ -in. unthreaded spindle. Shpg. wt. 3 lbs. 15 oz..... \$5.49

CRAFTSMAN Wood-turning Tools make shaping fast and easy

Professional quality. Brightly polished high carbon steel blades; 4 $\frac{1}{2}$ inches long. Tempered to take a keen edge. Expertly ground. 10-in. handles of smoothly finished hardwood. Heavy ferrule. Average length 14 $\frac{1}{2}$ inches.

Catalog No.	Description	Catalog No.	Description
7	9 M 2863 1-in. Skew Chisel. Wt. 11 oz.....\$1.59	12	9 M 2852 Gouge, $\frac{3}{16}$ in. wide. Wt. 13 oz.....\$1.59
8	9 M 2862 $\frac{1}{2}$ -in. Skew Chisel. Wt. 11 oz.....\$1.59	13	9 M 2851 Gouge, $\frac{1}{2}$ in. wide. Wt. 11 oz.....\$1.59
9	9 M 2856 $\frac{1}{2}$ -in. Rd.-nose Chisel. Wt. 11 oz.....\$1.59	14	9 M 2850 Gouge, $\frac{1}{4}$ in. wide. Wt. 10 oz.....\$1.59
10	9 M 2858 Parting Tool, $\frac{1}{8}$ in. wide. Wt. 11 oz.....\$1.59	9 M 2855	5-pc. Woodturning Set. 1 each of 8, 9, 10, 11, and 13. Wt. 2 lbs. 4 oz.....\$6.69
11	9 M 2854 Spear Point Chisel. $\frac{1}{2}$ in. Wt. 11 oz.....\$1.59		

- 15 CRAFTSMAN 4-piece. Wood-turning Set. Tough, keen-edged carbide-tipped steel blades. Cut wood, thermoplastics, aluminum, brass and other soft metals. Use at any desired lathe speed with wood, plastics and aluminum (slower speeds for harder metals). Set includes $\frac{3}{16}$ -inch parting tool, $\frac{1}{2}$ -inch round-nose chisel, $\frac{3}{4}$ -inch skew chisel, and $\frac{1}{2}$ -inch gouge. Hardwood handles. 4-inch blades. Average overall length 13 inches. Shpg. wt. 2 lbs. 6 oz. 9 M 3629—Complete set...\$14.49



CRAFTSMAN Instruction Manuals give you dozens of new ideas for using your power tools

- 16 "Power Tools and how to use them." 192 pages. 1100 illustrations cover 900 operations. 9 M 2912—Shpg. wt. 11 oz.....\$1.59
- 17 "The Drill Press." 32 pages, 200 illustrations cover over 100 operations. 9 M 2921—Shpg. wt. 2 oz..... 29c
- 18 "The Circular Saw." 32 pages, over 215 illustrations. Describes use of bench, electric hand, swing, builders' and radial saws; instructions for making 30 wood joints. 9 M 2926—Shpg. wt. 2 oz..... 29c
- 19 "The Jig Saw and Band Saw." Contains 32 pages with more than 160 illustrations. Describes many shortcuts in operation. Shipping weight 2 ounces. 9 M 2919..... 29c
- 20 "The Wood Lathe." 32 fully illustrated pages. Describes and illustrates in detail more than 150 wood-turning operations. Tells how to mount attachments not for wood-turning. 9 M 2920—Shpg. wt. 2 oz..... 29c
- 21 "The Jointer, Shaper and Thickness Planer" Instruction Book. A complete manual of operation. 32 pages, over 200 illustrations. Describes over 100 operations. 9 M 2916—Shpg. wt. 2 oz..... 29c
- 22 "How to Sharpen" Manual. Shows how to give almost any cutting tool a keen edge. Excellent for mechanics, farmers, home owners. 32 informative pages with more than 200 illustrations. 9 M 2924—Shpg. wt. 2 oz..... 29c
- 23 "Arc-Weld-it-Yourself" Manual. Step-by-step instructions on how to arc weld. Tells how to make repairs, build new equipment. Fine for farm welders. 36 pages, 165 illustrations. 9 M 2025—Shpg. wt. 3 oz..... 69c
- 24 Metal Lathe Manual. 258 pages of practical metal lathe operations (includes machinists' tables). Illustrations. Shipping weight 1 lb. 4 oz. 9 M 2925..... \$2.50
- 25 "The Oxy-Acetylene Welder's Handbook." Complete, practical manual for both beginners and experienced welders. Shows how to weld, cut and braze. 271 pages, many containing illustrations. 9 M 5411—Shpg. wt. 10 oz.....\$3.49

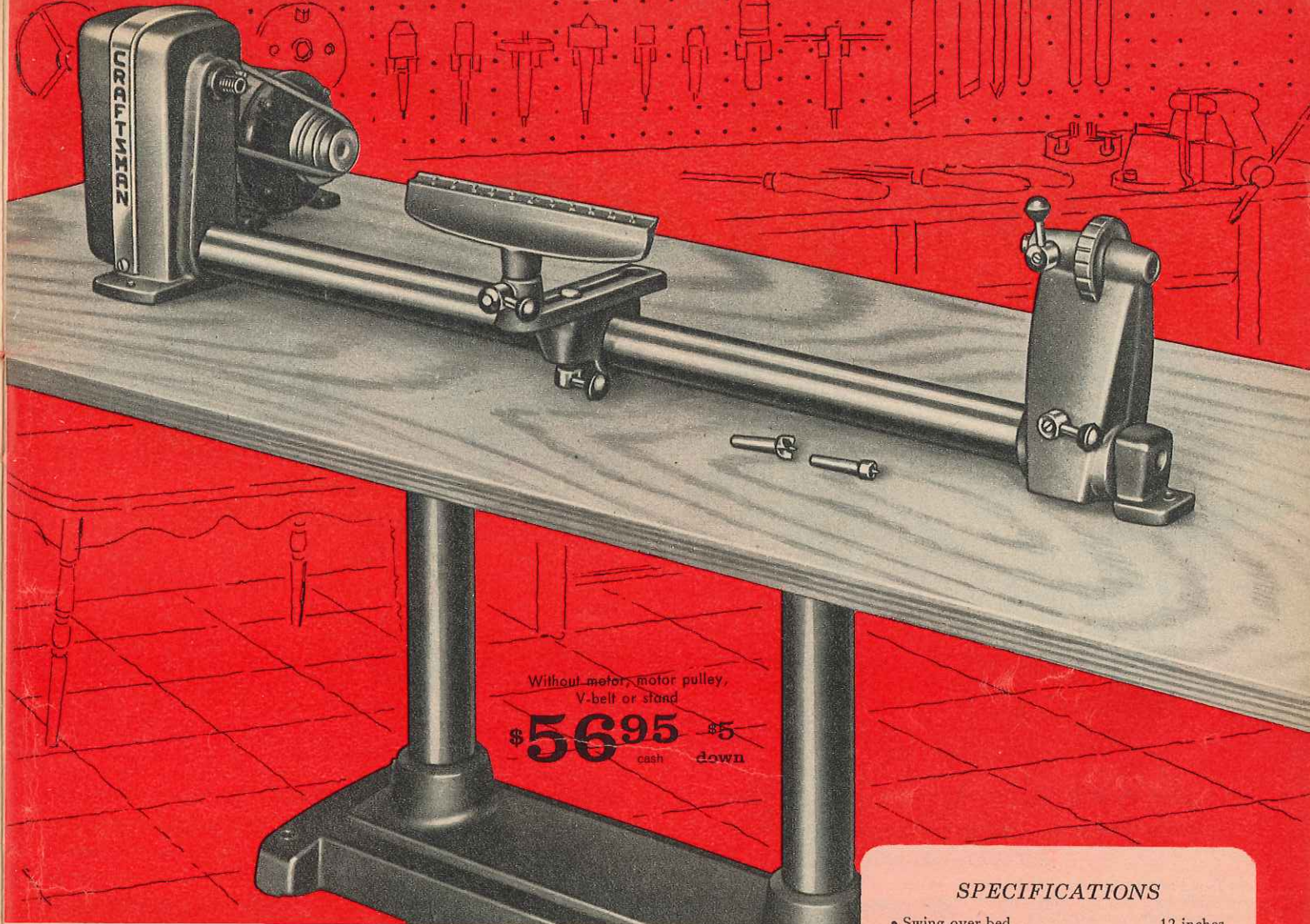

Without motor, motor pulley,
V-belt or stand
\$56.95 \$5
cash down

CRAFTSMAN Wood Lathe .. Ball-bearing spindle

REG. U.S. PAT. OFF.

Our finest .. 12-inch swing, 37 inches between centers, 45½-inch bed

A professional-quality shop tool at an economy price. Accurately and smoothly shapes your ideas in wood even at high speeds. A necessary tool for the well-equipped shop. Openings in headstock for driving spindle from the rear or below. Extra-heavy cast semi-steel headstock and tailstock. Precision-ground bed made of heavy, rigid steel tubing. 3-point mounting helps reduce twist and strain. Ball-bearing (lubricated for life) ¾x16-thread headstock spindle. No. 1 Morse taper in both headstock and tailstock. Tool rest and tool rest slide lock and unlock by hand, no wrenches needed. Indexing pin for use in fluting table legs and other furniture legs. Power-bronze finish. Length 54½ inches. Complete

with 12-inch graduated tool rest, spur and cup centers, 4-inches. 4-step machine pulley giving 4 speeds from 875 to 3450 RPM.

99 M 2388L—Without motor, motor pulley, V-belt or stand. Shpg. wt. 58 pounds. \$5.00 down, \$5.00 monthly. . . . Cash \$56.95
99 M 23885L2—With CRAFTSMAN ⅓ H.P. 1725 RPM split-phase motor, (110-120-volt, 60-cycle AC), 4-inch 4-step motor pulley and 41-inch V-belt. Shipping weight 84 pounds. \$5.00 down, \$5.00 monthly. Cash \$72.95

Pedestal Stand. For lathes 99 M 2388L (above) and 99 M 2160L on facing page.

99 M 2249N—Shipping weight 72 pounds. \$3.50 down, \$4.00 monthly. Cash \$31.50

SPECIFICATIONS

- Swing over bed 12 inches
- Distance between centers 37 inches
- Length of bed 45½ inches
- Spindle; inboard end. ¾-in. x 16 R.H. thread with No. 1 Morse, female taper
- Spindle speeds. 4:875, 1350, 2250, 3450 RPM
- Spindle bearings. . . . 2 sealed radial thrust ball
- Tailstock taper. No. 1 Morse, female
- Tailstock ram travel. 1½ inches
- Machine pulley (included). 4 inches 4-step V-type Cone
- Motor pulley (not included). 4 inches 4-step V-type Cone
- Motor recommended (min.):. ⅓ H.P., 1725 RPM.
- Mounting dimensions. . . . 49 ⅝x5 ⅜ inches (hole centers)
- Overall dimensions: height 11 11/16 inches; width 7 1/16 inches; length 54 1/2 inches.

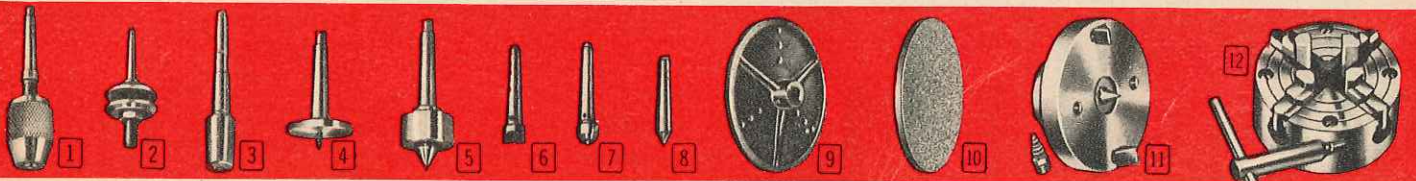

- 1 Work Arbor with Chuck. 3-jaw screw-on type chuck. ½-inch capacity; tapped ½-inch x 20-thread. No. 1 Morse taper on shank. 9 M 2234—Shipping weight 1 pound 8 ounces. \$2.85
- 2 Work Arbor. ½ in. x 20-thread. 2 steel flanges for clamping wheels. No. 1 Morse taper. 9 M 2153—Shipping weight 9 ounces. \$1.49
- 3 Chuck Arbors. Precision ground. 9 M 2123—Fits 9 M 2142 and 9 M 2143 chucks (listed on page 42). No. 1 Morse taper and No. 33 Jacobs taper. Shipping weight 1 pound 6 ounces. \$1.29
9 M 2154—Fits 9 M 2129, 9 M 2144, 9 M 2991. (Pg. 42) No. 1 Morse taper, No. 3 Jacobs taper. Wt. 8 oz. 1.29
- 4 Screw Center. Replaceable center. No. 1 Morse taper on shank end. 9 M 2116—Shipping weight 12 ounces. \$1.79

- 5 Precision Ball-bearing 60° Center. Point rotates on ball bearing. No. 1 Morse taper shank. 9 M 2112—Shipping weight 8 ounces. \$3.49
- 6 Spur Center. No. 1 Morse taper on shank end. 9 M 2106—Shipping weight 4 ounces. 1.29
- 7 Tailstock Cup Center. No. 1 Morse taper. Replaceable center point. 9 M 2100—Shipping weight 4 ounces. \$1.29
- 8 60° Center. No. 1 Morse taper on shank end. 9 M 2110—Shipping weight 4 ounces. 98c
- 9 Face Plates. Fit any ¾-in. x 16-thread spindle. 9 M 2489—4-in. For inboard turning. Wt. 1 lb. 7 oz. \$2.79
9 M 2490—8-in. For inboard turning. Wt. 3 lbs. 13 oz. \$5.49
9 M 2492—8-in. For outboard turning. Shipped from Chicago, Ill. Shpg. wt. 2 lbs. \$5.49

- 10 Sanding Plates. Made of high-quality cast iron. Accurately machined for precision balance. Fitted with 8-inch sandpaper disc. 9 M 2491—8-inch diameter. For wood lathe 99 M 2388L above and other lathes with ¾-inch x 16 right-hand thread spindle. Shipping weight 3 pounds 13 ounces. \$5.49
- 11 Face Plate. 3-inch diameter. With spurs, removable center, screw center. For wood lathe 99 M 2388L above, other lathes with ¾-inch x 16-thread spindle. 9 M 2091—Shipping weight 1 pound 12 ounces. \$2.29
- 12 Craftsman Independent 4-jaw Lathe Chuck. Four reversible drop-forged jaws; work independently. Body of special alloy steel. Deep, wide slots allow use of heavy, rugged jaws. T-handle wrench included. Fits wood lathe 99 M 2388L above and other lathes with ¾-inch x 16-thread spindle. 9 M 2156—Shipping weight 3 pounds 14 ounces. \$11.59

USE SEARS SPECIAL EASY TERMS for Power Tools . . see inside back cover

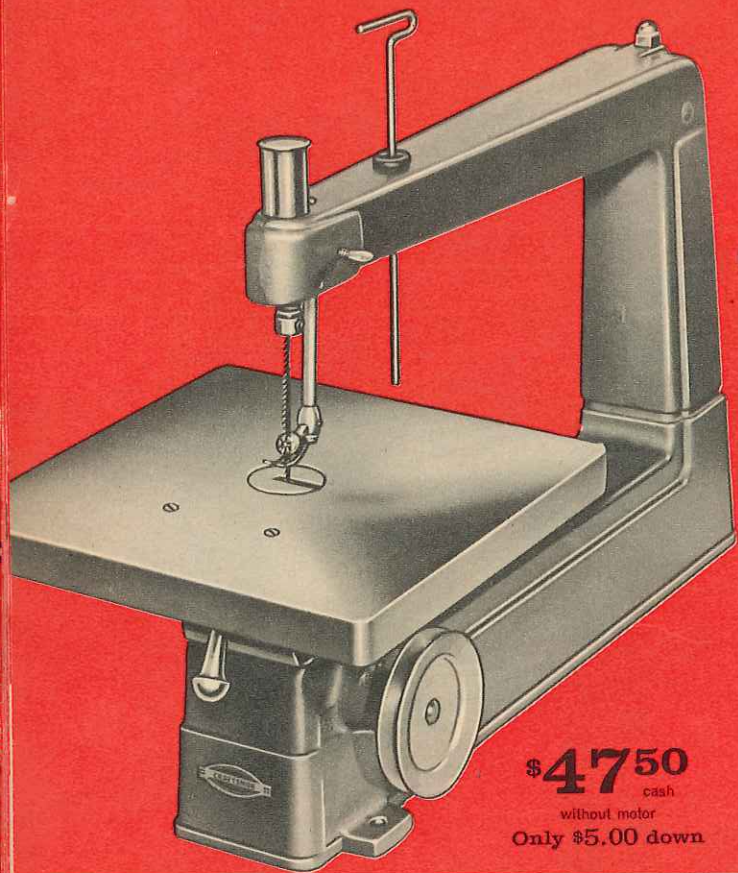

\$4750 cash
without motor
Only \$5.00 down

CRAFTSMAN 18-inch Belt-driven Jig Saw
Removable arm . . use saw for filing or sabre sawing

SPECIFICATIONS

- Depth of throat 18 inches
- Table size 12x12 inches
- Sawdust blower . . . built into head
- Stroke 1 inch
- Machine pulley (incl.) . . . 4 inches
- Motor recommended (minimum) 1/3-HP, 1725 RPM
- Mounting dimensions (three-point) 5 1/4 x 22 7/16 inches
- Over-all dimensions height 18 in.; width 12 in.; length 29 in.
- Depth of cut (maximum) . 2 inches
- Bearings porous bronze
- Length of blade 6-inch plain end
- Spindle speed (approx.) . 875 RPM
- Motor pulley (not incl.) . . 2 inches

Table tilts from 0 to 45° for mitering or beveling. Zips through all woods up to 2 in. thick. . also cuts plastics and non-ferrous metals. Ideal for making cornices, cabinets or doing other intricate jobs. (Uses 5 or 6-in. plain-end blade—one supplied.) Bearings run in bath of oil . . smooth, quiet operation.

Four outstanding features and benefits: (1) resilient chuck shoe between blade and clamp cushions the blade . . prevents twisting and breaking; (2) blade rests against movable steel balls in back-up guide . . reduces blade wear caused by friction; (3) guide can be adjusted in all directions . . always precise alignment for maximum support when blade is rotated for back-cutting or ripping pieces over 18 inches long; (4) cap floats radially to insure perfect vertical alignment. *Shipped freight (rail or truck) or express.*

99 M 2072N—Without motor, motor pulley, V-belt. Shpg. wt. 70 lbs. \$47.50
99 M 20725N2—With CRAFTSMAN 1/3-HP 1725 RPM split-phase motor (110-120-volt, 60-cycle AC), 2-in. motor pulley, 1/2 x 54-in. V-belt. Shpg. wt. 95 lbs. \$63.50

CRAFTSMAN Jig, Fret, Coping Saw Blades of tough alloy steel . . heat treated and hardened

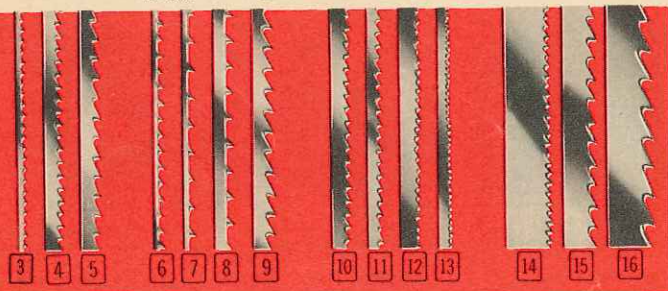

Professional quality blades . . made of special alloy steel, scientifically heat treated and hardened for long life and fast, easy cutting action. All blades listed are for use on jig saws. 6-inch plain-end blades can be snapped off to fit machines taking shorter plain-end blades. When cutting metal with blades indicated for metal cutting, lubricate blade with beeswax.

Sabre-tooth blades can be used for heavy work, as well as for sabre sawing on jig saws. *Please be sure to order by correct catalog number from table at right.* Shipping weight per package 2 ounces.

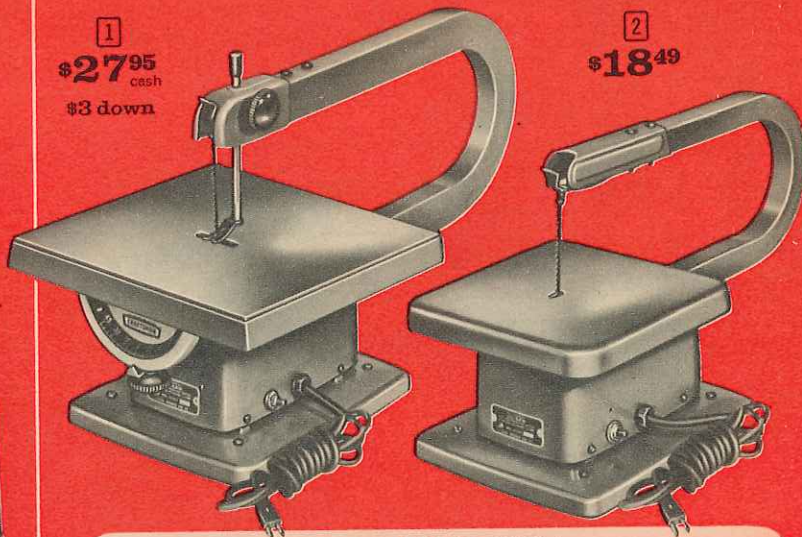

1
\$2795 cash
\$3 down

2
\$1849

SPECIFICATIONS

	1 99 M 2571C	2 99 M 2570C
• Depth of throat	15 inches	12 inches
• Depth of cut	1 1/2 inches	1 1/2 in. (1 in. recommended)
• Blade chuck	rotates 90° left, right	rotates 90° left, right
• Table size	10x10 inches	8x8 1/2 inches
• Motor (built in)	reciprocating type, 110-120-volt, 60-cycle AC	reciprocating type, 110-120-volt, 60-cycle AC
• High speed stroke	7200 per minute	7200 per minute
• Bearings	steel torsion	steel torsion
• Blades	5-in. pin end (4 incl.)	4-in. pin end (2 incl.)
• Dimensions	height 11 1/4 in.; width 10 1/4 in.; length 21 1/4 in.	height 10 1/4 in.; width 8 in.; length 17 in.

Enclosed motors for safe, quiet operation

CRAFTSMAN 15-in. Jig Saw . . table tilts
Guaranteed ONE year against defects

12-in. hobbyists' Jig Saw
Plug in and use anywhere

1 Table tilts 0 to 45° in either direction . . with adjustable, calibrated scale tilt control. A powerful, rugged tool, yet light enough for easy portability. Cuts to center of 30-inch circle. Lets you start inside cuts within the center section of work . . cut fancy veneer inlays . . saw almost invisible coped joints. Blade leaves no saw marks . . no need for sanding. Cuts hard and soft woods, plywood, wall and floor tile (except ceramic), plastics and non-ferrous metals. Equal in power to many heavier saws, yet runs quietly. *UL approved.*

2 Safe enough for even children to operate. Rapid, short strokes of this rugged, well-made power tool leave practically NO saw marks . . means you have little if any sanding to do. Short stroke and absence of pulleys and belts give you maximum safety.

All-metal construction; non-slip, sound-deadening rubber feet. Short stroke and twin-armature motor (no belts or pulleys . . never needs oiling) make saw safe even for children. Blade rotates 90° left or right for making cuts over 15 inches; locks in any position. Blade hooks adjust blade for true cut. Has locking hold-down device; bronze blade guide under table; pressure foot. With blades, 5-foot 3-wire cord, adapter, screwdriver.

Cuts 1-inch soft woods, plywood, Masonite, asphalt, plastic and aluminum tile; also thin metals such as brass, aluminum, etc. Blade can be turned 90° for making long cuts. Blade hooks permit adjusting blade to obtain true cut. Perfect for making models, jig saw puzzles, etc.

99 M 2571C—With instructions. Wt. 16 lbs. \$27.95

UL approved. Built-in motor never needs oiling. Portable . . has non-scratch rubber feet. With blades, 5-ft. 2-wire SJ cord, screwdriver and instructions.

99 M 2570C—Wt. 11 lbs. \$18.49

Catalog Number	Lgh., in.	Width, in.	Thick., in.	Teeth per in.	Recommended uses	Number in pkg.	Per pkg.
(Pin type blades)							
(3) 9M2688	4	.040	.010	18	For wood and plywood. Fit magnetic or reciprocating-motor jig saw.	8	35c
9M2687	4	.080	.010	18	For wood and plywood. Fit magnetic or reciprocating-motor jig saw.	8	35c
9M26903	5	.095	.015	20	For wood, plastic, soft metal. Fit magnetic or reciprocating-motor jig saw.	4	45c
(4) 9M26923	5	.187	.015	15	For wood, plastic, soft metal. Fit magnetic or reciprocating-motor jig saw.	4	45c
(5) 9M27053	5	.110	.020	15	Medium; for wood.	4	45c
9M27043	5	.110	.020	10	Coarse; for wood.	4	45c
(Plain-end blades; for most jig saws)							
(6) 9M26953	6	.070	.010	14	For thin woods, celluloid fiber composition board and hard rubber.	5	45c
(7) 9M27113	6	.070	.020	7	For plastics and metal.	5	45c
(8) 9M27103	6	.110	.020	7	Heavy duty; for plastic and metal.	5	45c
(9) 9M27003	6	.110	.020	10	Coarse; for wood and soft metal.	4	45c
(10) 9M27013	6	.110	.020	15	Fine; for wood and soft metal.	4	45c
(11) 9M27023	6	.085	.020	15	Extra fine; for wood and soft metal.	4	45c
(12) 9M27093	6	.110	.020	20	For sheet metals, including steel.	4	45c
(13) 9M27035	6	.070	.020	32	For sheet metals, including steel.	4	45c
(Sabre blades)							
(14) 9M28673	6	.250	.028	20	For wood and metal.	3	39c
(15) 9M28693	6	.187	.028	10	For wood and soft metal.	3	39c
(16) 9M28663	6	.250	.028	7	For coarse cuts in wood.	3	39c

CRAFTSMAN Wood Shaper

REG. U.S. PAT. OFF.

with 3 big EXCLUSIVE features

1. Extra-big 27x19-inch polished, ground semi-steel table
2. Fence adjusts either side in or out without loosening
3. Control for spindle height adjustment is easily accessible in all positions. No interference from legs, etc.

SPECIFICATIONS

- Cutter height capacity...2½ in.
- Cutter bore.....½ inch
- Bearings.....2 sets sealed ball
- Table height (stationary) 8¾ inches above base
- Miter gauge slot ¾ in. x ¾ in.
- Length of fence...18¾ to 21 in.
- Spindle diameter...½-inch ends 1¼-inch center
- Spindle thread...½ in.x16 Acme
- Spindle adjustment....¾ inch
- Spindle speed recommended 9,000 RPM.
- Machine pulley (included)...2 in.
- Motor pulley (incl.)...4¾ in. flat
- V-belt (included)...½x33 inches
- Motor recommended (minimum)...½ HP, 3450 RPM
- Mounting dimensions...3 holes: 2 rear are 11½ in., front is 9¼ in.
- Height 11½ in.; width 27 in.; Depth less motor guard 19 in.

High-speed, precision-machined to give you ACCURACY!

Here are 5 more outstanding features: (1) Floating upper bearings for greater accuracy...two sets of sealed radial bearings; lubricated for life. (2) All critical parts are precision-machined for best results at high speed. (3) Built-in guard completely encloses belt, motor pulley for safety. (4) Collars, nuts and washers are hardened to prevent burring. (5) Increased spindle diameter between bearings prevents whip and vibration.

Spring hold-downs. Solid-type spindle rotates in either direction. 3 spindle collars. "Power bronze" finish. Sent freight (rail or truck) or express.

99 M 2392N—Without motor or stand. Shpg. wt. 87 lbs. \$5 monthly. Cash \$74.95

99 M 23927N2—As above, but with ½-HP 3450 RPM, ball-bearing capacitor motor. For 110-120-volt, 60-cycle AC. Shpg. wt. 116 lbs. \$5 down, \$5 monthly. Cash \$104.95

CRAFTSMAN Pedestal Tool Stand for above. About 33 inches high. 2¾-inch diameter steel column. Cast iron base. 4 tapped holes in base for casters.

99 M 2226L—Shipping weight 41 pounds. \$2.50 down, \$4 monthly. Cash \$23.95

CUTTERS FOR SHAPER ABOVE ON PAGE 29

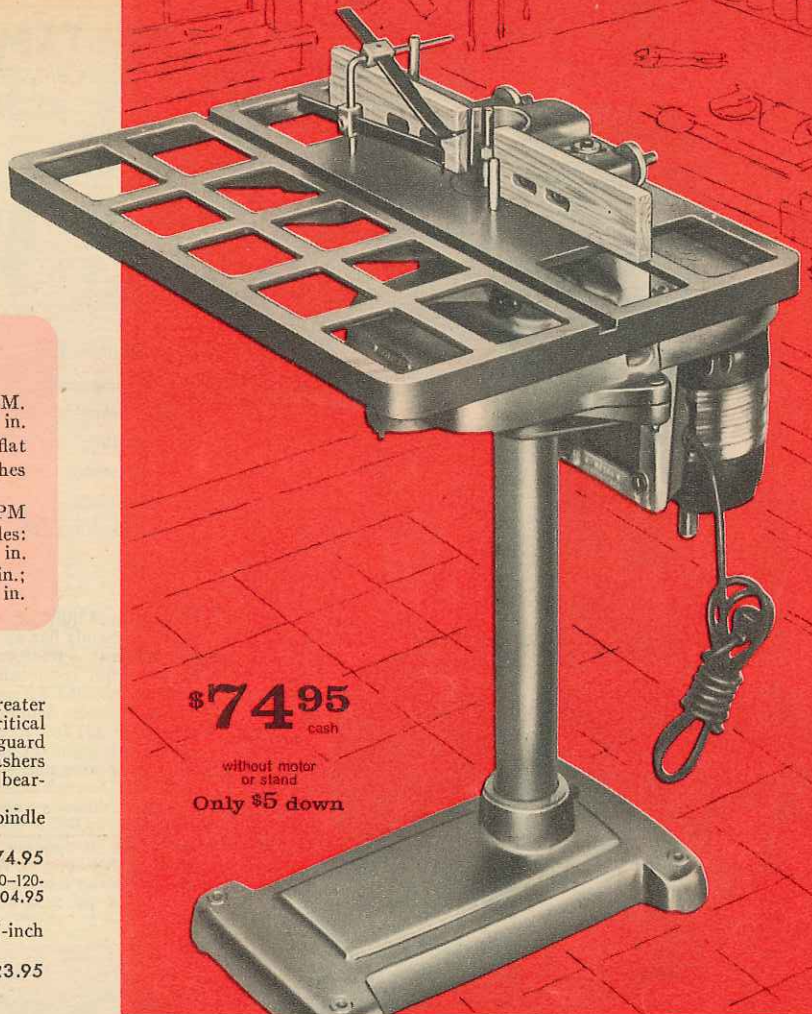

\$74.95
cash

without motor
or stand
Only \$5 down

BUILD IT YOURSELF with these EASI-BILD PATTERNS

Easi-Bild Patterns make building with wood, metal, panel-board or plastics as easy as 1-2-3-4. Just follow the directions: (1) Cut out Pattern; (2) Trace; (3) Saw; (4) Assemble. Eliminates the wasteful use of materials and labor. Each pattern contains a list of materials needed.

No special skill required to obtain professional results. Step-by-step assembly illustrations show every important phase of construction. Full-size patterns are provided wherever necessary...where no full-size pattern is required, the exact cutting dimensions are given. Shpg. wt. each 2 oz.

9 M 2990—State Pattern Nos. wanted any 4 for \$1.00

- Number 1—Wide Window Valance (fancy edge) side shelves
- Number 9—Bird Feeder
- Number 25—Magazine Rack
- Number 27—Window Valance . . . scalloped edge
- Number 30—Colonial Window Valance
- Number 34—Giraffe Clothes Tree
- Number 71—Tool Chest
- Number 81—Lawn Ornaments
- Number 83—Barnyard Animals
- Number 111—Wren House
- Number 313—Telephone Shelf
- Number 353—Tot's Step-Stool
- Number 581—Rooster Wall Plaque
- Number 587—Wise Owl Driveway Marker
- Number 539—Primitives

9 M 2990—State Pattern Nos. wanted any 3 for \$1.00

- Number 21—Hanging Bookshelf
- Number 29—Bathroom Valet
- Number 35—Knickknack Shelf
- Number 193—Modern Cabinet
- Number 301—Shadow Boxes
- Number 311—Modern Chair

9 M 2990—State Pattern Numbers wanted any 2 for \$1.00

- Number 15—Handy Work Bench
- Number 18—Bookcase Hide-A-Desk
- Number 28—Dog House
- Number 32—Lawn Chair
- Number 33—Dream Doll House
- Number 42—Modern Bookcase
- Number 51—Tool or Garden House
- Number 53—Pony Ride Rocker
- Number 56—Foldaway Chair
- Number 73—Outdoor Fireplace
- Number 78—Garden Chaise
- Number 90—Stand-up Bar
- Number 101—One-Car Garage
- Number 436—Record Cabinet
- Number 531—Noel Greeting
- Number 540—Madonna Christmas Card (4 feet high)
- Number 562—Choir Boys Greeting
- Number 568—Stor-All Work Bench
- Number 524—Rooster Weathervane
- Number 962—Storage Chest
- Number 126—Headboard Storage Unit
- Number 130—Rod and Gun Cabinet
- Number 247—Cartop Swimming Float
- 9 M 2990—State Pattern Numbers wanted any 2 for \$1.50
- Number 89—Lean-to tool Shed
- Number 139—Wardrobe
- Number 155—Lawn Glider

9 M 2990—State Pattern Numbers wanted any 1 for 1.00

- Number 85—Utility Boat
- Number 201—Kitchen Cabinets
- Number 266—Sportsman's Cabinet
- Number 575—6-foot Santa Claus
- Number 736—Built-in Storage Wall
- Number 942A—Paint-It-Yourself Christmas Mural, Window Size, 4x6 feet.
- Number 263—Storage Wall on Casters
- Number 264—Wall-to-Wall Bookcase
- Number 312—Beverly Hills Chaise
- Number 323—Folding Picnic Table
- Number 331—Outdoor Xmas Greeting
- Number 430—Sliding Door Wall
- Number 431—Santa Claus Decoration
- Number 433—Christmas Reindeer
- Number 434—The Santa Claus Sleigh
- Number 315—Williamsburg Fence, Gate
- Number 544—Radiator Enclosure
- Number 548—Modern Web Chair
- Number 554—Outdoor Dining Table
- Number 576—Foldaway Workshop
- Number 586—Colonial Cobbler's Bench
- Number 592—Outdoor Christmas Card
- Number 936—Outdoor Easter Greeting
- Number 937—Garden Privacy Partition
- Number 941—Rail Fence and Gate
- Number 773—Colonial Baby Cradle
- Number 774—Console Table
- Number 718—Buffet Bar
- Number 577—Picnic Table
- Number 770—Shelf Unit . . . fits on door
- Number 270—Hutch Cabinet
- Number 589—Colonial Cupola

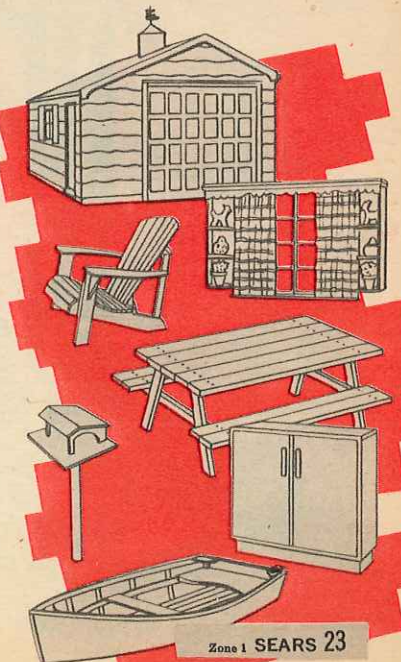
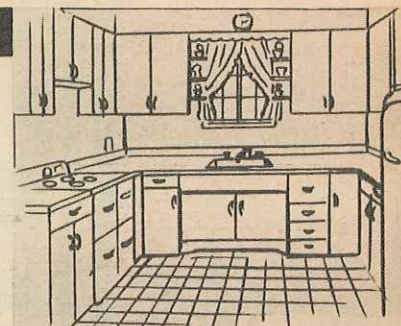

Build your order to \$20 or more . . .
See EASY TERMS inside back cover

CRAFTSMAN Belt and Disc Sander

REG. U. S. PAT. OFF.

6-inch belt plus a 9-inch disc in one tool!

Without motor, pulley, V-belt, guard or stand **\$57.50** \$5 down
cash

SPECIFICATIONS

- Width of belt 6 in.
- Circumference of belt 48 in.
- Sanding belt table 6½x17 9/16 in.
- Sanding disc table 6¼x12 in.
- Diameter of sanding disc 9 in.
- Bearings 3 sets; sealed ball
- Drum diameter 3 in.
- Machine pulley (included with unit) 2½ in.
- Motor pulley (not included with unit) 2 inches
- Motor recommended . ½-HP, 3450 RPM
- Overall dimensions . . 10 1/16x18x28 3/8 in.
- Mounting dimensions (center to center of bolt holes) 10 3/4 inches

Designed and built for industrial production or for work of the serious amateur. Sands flat and curved surfaces. Use belt sander for large flat surfaces . . end drums for curved or irregular work . . disc sander for end grain and small work. Has more than 100 square inches of work surface PLUS 3 exclusive features: (1) Two sealed ball bearings on drive shaft; double row of sealed ball bearings integral with idler shaft. (2) Drive roller and V-pulley are keyed to drive shaft to prevent slippage. (3) Easily accessible knobs for adjusting belt tension—no locking needed.

Adjustable work table tilts to any angle from 0° to 45°. No gouging of long work—drive and idler roller slightly lower than belt table. Fence adjusts 90° to 45°. Heavy cast iron frame.

99 M 2250L—Without motor, pulley, belt, guard, stand. Wt. 62 lbs. . . . \$57.50
99 M 22507L2—With ½-HP, 3450 RPM motor for 110-120-volt, 60-cycle AC, ½x40-inch V-belt and 2-inch motor pulley. Stand and belt guard not included; see listings at right. Shpg. wt. 92 lbs. \$5.00 down. Cash \$89.50

Pedestal Stand (shown with Sander at left). Has caster holes, brackets, motor mount and bolts. Casters not included. See page 37 for 9 M 2819 caster set; page 36 for 9 M 21205 Power-Pak. Shpg. wt. 49 lbs.
99 M 2204L \$25.95

Belt Guard (shown with Sander at left). Use with Pedestal Stand listed above. Steel construction. Shpg. wt. 2 lbs. 13 oz.
9 M 2251 \$5.79

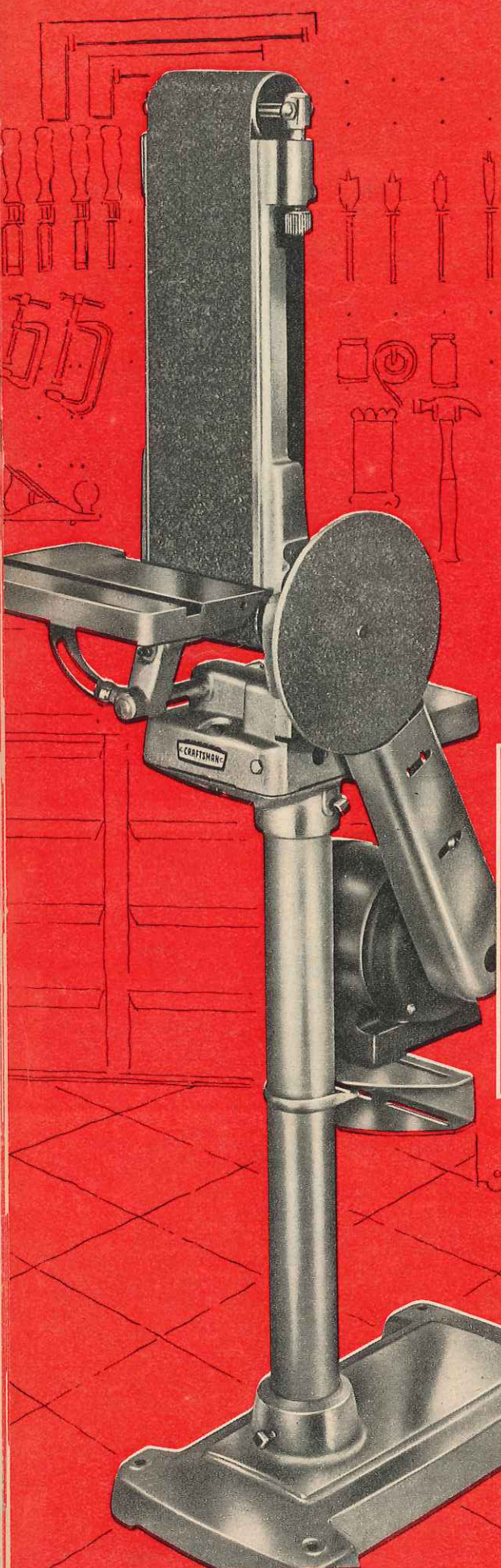

1
Without motor, motor pulley or V-Belt
\$18.98

2
Without motor
\$26.95
cash
\$3 down

OUNLAP 4-inch Belt Sander

1 Sands flat work with belt . . curved and irregular work with end drums. Can be used on either wood or metal. Cast semi-steel body and table. 3-point mounting. Medium-grit aluminum oxide belt is easy to align because it can be adjusted from both sides. Includes easily adjustable fence to help guide work.

Specifications: Width of belt, 4 inches; circumference of belt, 36 inches; sanding belt table surface, 4½x12 inches; bearings, self-lubricating porous bronze; diameter of drum, 2½ inches; machine pulley (included), 2 inches; motor pulley (not included), 2 inches; motor recommended, ¼ HP 1725 RPM; mounting dimensions, 5 1/4 x 7 9/16 inches; overall dimensions, 6 3/16 x 9 x 16 5/8 inches.

99 M 2236C—Without motor, motor pulley or V-belt. Shipping weight 20 lbs. \$18.98

99 M 22365K2—With ½-HP 1725 RPM motor (110-120-volt, 60-cycle AC), ½x40-inch belt, 2-inch motor pulley. Shpg. wt. 45 lbs. \$35.98

CRAFTSMAN 12-inch Disc Sander

2 Ideal for heavy-duty industrial-type use. Large abrasive disc sands wood or metal. Trues, miters and squares. Powerful direct drive—no belt to slip—gives greater efficiency and compactness. Large tilting table with handy knob to locate and hold angle. Accurate scale and pointer. Small clearance between disc and table keeps work from catching. Adjustable support takes ¼-HP or larger motor.

Specifications. Disc diameter, 12 inches; table work surface, 16x6 1/2 inches; maximum forward table tilt, 45°; maximum backward table tilt, 20°; miter gauge slot, 3/4 inch wide, 3/8 inch deep; minimum motor recommended, ¼ HP 1725 RPM; overall dimensions, 13x16x17 inches; clearance between disc and table, 1/8 inch.

99 M 2237L—Sander without motor.

Shipping weight 42 pounds. \$3 down. Cash \$26.95
99 M 22378L2—Sander with ½-HP 1725 RPM split-phase motor (110-120 volt, 60-cycle, AC) and 2 aluminum oxide discs. Shipping weight 66 pounds. \$4.50 down. Cash \$42.95

12-inch Aluminum Sanding Plates. With set screws.
9 M 22376—½-inch bore. Shpg. wt. 3 lbs. 2 oz. \$4.98
9 M 22377—¾-inch bore. Shpg. wt. 3 lbs. 2 oz. 4.98

For Sanding Discs, Sanding Belts and Disc Cement for Sanders on this page, see page 27

USE SEARS SPECIAL EASY TERMS for Power Tools . . see inside back cover



CRAFTSMAN Adhesives for every purpose . . . choice of nine types

REG. U. S. PAT. OFF.

- 1 Hide Glue.** Ideal glue for cabinetmakers. Makes a durable wood bonding that becomes stronger than the wood itself. Also excellent for leather, fabrics, cardboard, other porous materials. *State size, quantity.*
 9 M 8062—1-ounce size. Shipping weight 4 oz. 25c
 4-oz. size. Shpg. wt. 10 oz. 55c 8-oz. size. Shpg. wt. 14 oz. 89c
- 2 Casein Glue.** Easy to mix. Makes a very strong water-resistant glue. Perfect for working outdoors because it sets at low temperatures.
 9 M 8063—12-ounce can. Shipping weight 1 lb. 2 oz. 79c
- 3 Contact Cement.** Bonds instantly on contact, no clamping needed. Bonds plastic laminates on tables, sinks, cabinets. Also bonds porous and non-porous materials to wood, leather, linoleum, rubber. *State size.*
 9 M 8065—4-ounce size. Shipping weight 7 oz. 49c
 16-oz. size. Shipping weight 1 lb. 5 oz. \$1.29
- 4 Plastic Resin Glue.** A slow-setting, non-staining, highly water-resistant glue. For furniture, veneering, cabinet-making, other wood gluing. *State size.*
 9 M 8066—4-oz. size. Shipping weight 10 oz. 35c
 8-oz. size. Wt. 11 oz. 65c 16-oz. size. Wt. 1 lb. 2 oz. 95c

- 5 Waterproof Wood Glue.** Completely waterproof and weatherproof bonds ALL porous materials. Use it on boats, outdoor furniture, sports equipment, other demanding jobs. *State size.*
 9 M 8064— $\frac{1}{4}$ pint. Shipping weight 14 ounces. \$1.09
 1 pint. Shipping weight 2 pounds 4 ounces. 2.98
- 6 Plastic Rubber.** Chemically vulcanizes and waterproofs without heat. Rubber in putty form. Easy to use . . . molds into any shape. Use it to waterproof, insulate, repair, caulk. Stays elastic.
 9 M 8067—4-ounce tube. Shipping weight 10 ounces. 89c
- 7 Plastic Aluminum.** Solders, seals, patches around home, auto, boat, farm and shop. Adheres to metal, wood, leather, plastics, concrete. No tools, heat or flame required. Can be burnished to a lustre.
 9 M 8069— $\frac{5}{8}$ -ounce tube. Shipping weight 10 ounces. 89c
- 8 All-purpose Cement.** For most home and shop jobs. Vinyl base . . . mends all vinyl plastics, china, glass, ceramics, cloth, paper and leather. Waterproof—use indoors or out. Gets harder with age.
 9 M 8068—2-ounce size. Shipping weight 6 ounces. 49c

CRAFTSMAN All-purpose White Glue . . . strong, clear

Plastic squeeze bottle can't spill if tipped . . . allows you to squeeze out exact amount needed. Applicator tip puts glue right where you want it.
 Good for repairing furniture, loose veneers, toys, books, games, pottery, building models—even coating photos—because it sets quickly, dries clear.
 9 M 8061—State size and quantity.
 2-ounce size. Shpg. wt. 6 ounces. 35c
 4-ounce size. Shpg. wt. 9 ounces. 55c
 8-ounce size. Shpg. wt. 14 ounces. 89c
 16-ounce size. Shpg. wt. 1 lb. 9 oz. \$1.59

Type of adhesive	White Glue	Hide Glue	Casein Glue	Plastic Resin	Waterproof Wood Glue	Contact Cement	All-purpose Cement	Plastic Aluminum	Plastic Rubber
Advantages:	Sets fast, dries clear. Bonds porous materials.	Extremely strong wood glue. Comes ready to use.	Bonds at low temperatures. Easy to use.	Resists moisture. Non-staining. Easy to use.	Completely waterproofs. Best for exterior use.	Bonds on contact. No clamps necessary.	Clear, dries fast, stays flexible. Waterproof.	Metal in putty form. Bonds, fills at same time.	Elastic rubber in easy-to-use putty form.
Use for:	Wood, porous materials. Household repairs.	Furniture, cabinets, wood-to-wood bonds.	Woodwork, if moisture is problem. Oily woods.	Woodwork, if moisture is problem.	Anything exposed to prolonged soaking.	Plastic laminates, wall panels, metal foils.	Most light gluing jobs. Bonds all vinyl plastic.	Solder, seal, repair gutters, most metal items.	Vulcanize, waterproof, caulk, repair rubber.

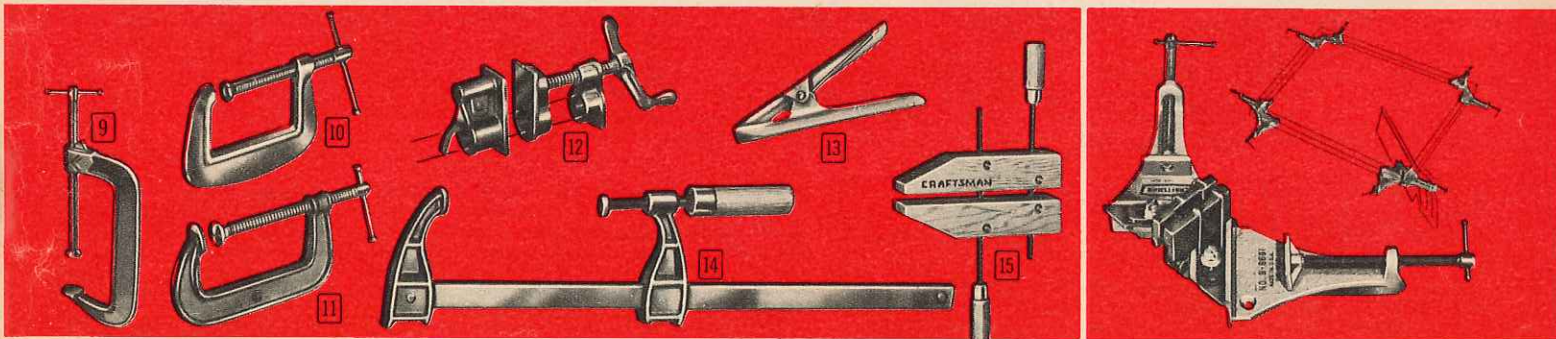

Complete clamp assortment . . . the "extra hands" for your shop!

- 9 Rapid-action C Clamp.** At least 50% faster than ordinary clamps because you don't have to twist screw to new position. Just press spring-held screw nut . . . screw slides to next setting. Release nut . . . tighten screw for a steady clamp. Malleable iron.
 9 M 6680—State size and quantity.
- | Size | Throat | Shpg. wt. | Each |
|--------|---------------------|---------------|--------|
| 6 in. | 2 $\frac{3}{4}$ in. | 3 lbs. 12 oz. | \$3.39 |
| 8 in. | 3 $\frac{1}{4}$ in. | 4 lbs. 14 oz. | 3.98 |
| 10 in. | 3 $\frac{1}{2}$ in. | 6 lbs. 5 oz. | 5.49 |

- 10 Aluminum Alloy C Clamps.** Won't rust or warp. Steel screw.
 9 M 6670—State size and quantity.
- | Opens to . . . | 1 in. | 2 in. | 3 in. | 4 in. |
|----------------|-------|-------|-------|--------|
| Wt. each . . . | 3 oz. | 5 oz. | 8 oz. | 13 oz. |
| Each | 39c | 59c | 98c | \$1.39 |

- 11 Malleable Iron C Clamps.** Steel screw with sliding handle.
 9 M 6667—State size and quantity.
- | Opens to | Throat depth | Shipping weight | Price |
|---------------|-----------------------------|-----------------------|--------|
| 1 in. | 1 in. | 4 oz. | 29c |
| 2 in. | 1 $\frac{1}{8}$ in. | 7 oz. | 39c |
| 3 in. | 1 $\frac{3}{4}$ in. | 15 oz. | 79c |
| 4 in. | 2 in. | 2 lbs. 2 oz. | \$1.49 |
| 5 in. | 2 $\frac{1}{2}$ in. | 2 lbs. 8 oz. | 1.79 |
| 6 in. | 2 $\frac{3}{4}$ in. | 2 lbs. 14 oz. | 1.89 |

- Deep Throat C Clamps.** Pearlitic iron, 20% stronger than malleable.
 9 M 6668—State size and quantity.
- | Opens to . . . | 1 in. | 2 $\frac{1}{2}$ in. | 4 in. |
|-------------------|-------|---------------------|---------------|
| Throat | 3 in. | 4 $\frac{1}{2}$ in. | 5 in. |
| Shpg. wt. | 9 oz. | 1 lb. 8 oz. | 2 lbs. 11 oz. |
| Price | 49c | 98c | \$2.49 |

- 12 Gluing Clamp.** Use with $\frac{3}{8}$ -in. threaded pipe (not incl.). Jaw has $1\frac{1}{2}$ x $1\frac{1}{8}$ -in. face. With pipe cap. Shpg. wt. 3 lbs. 3 oz.
 9 M 6674 Each \$2.89

- 13 Spring Clamp.** Heavy gauge steel.
 9 M 6669—State size and quantity.
- | Opens | Length | Shpg. wt. | Each |
|--------------------|--------------------|---------------------|------|
| 1 inch | 4 inches | 3 ounces | 35c |
| 2 inches | 6 inches | 10 ounces | 49c |
| 3 inches | 9 inches | 1 pound | 79c |

- 14 Light service Bar Clamps.** Grips bar at any point. Jaw depth 2 $\frac{1}{2}$ in. *State size.*
 9 M 6665—18 in. Shpg. wt. 2 lbs. 5 oz. \$2.69
 9 M 6665C—24 in. Shpg. wt. 3 lbs. 2.98

- 15 CRAFTSMAN Adjustable Gluing Clamps.** Select hard maple jaws. *State size.*
 9 M 6663—4 in. Shpg. wt. 2 lbs. 2 oz. \$3.49
 7 in. Shpg. wt. 3 lbs. 6 oz. 4.49
 10 in. Shpg. wt. 5 lbs. 2 oz. 5.59

CRAFTSMAN Cut 'n' Clamp Set for perfect miter joints

Just clamp, cut and reclamp! For gluing, nailing, or stapling perfect 90° angles. Custom-built picture frames, screens, even storm sashes. Use any back saw or hand saw (not included). CRAFTSMAN Miter Box Corner Clamp takes stock up to 3 inches wide. Guides adjust for width of saw. Clamp can be bolted to work bench. Set consists of aluminum alloy 45° miter box corner clamp and 3 corner clamps.
 9 M 66614—Shpg. wt. 3 lbs. 6 oz. \$5.89
 9 M 6661—45° Miter Box Corner Clamp only. Shipping weight 1 pound 2 ounces. \$1.98
 CRAFTSMAN Corner Clamp and Miter Vise. For clamping frames, screens, trim, miter or butt joints, etc.; hold at 90° angle. For stock up to 3 in. wide. *State quantity.*
 9 M 6666—Shpg. wt. 12 oz. Each \$1.39

Fast-cutting Karbo-Grit Tools last for years

Outdate ordinary tools because they cut and smooth:

All Woods	Laminates	Masonite
Plastics	Wall Board	Fiber Glass
Formica	Plywood	Aluminum
Composition	Plaster	Brass

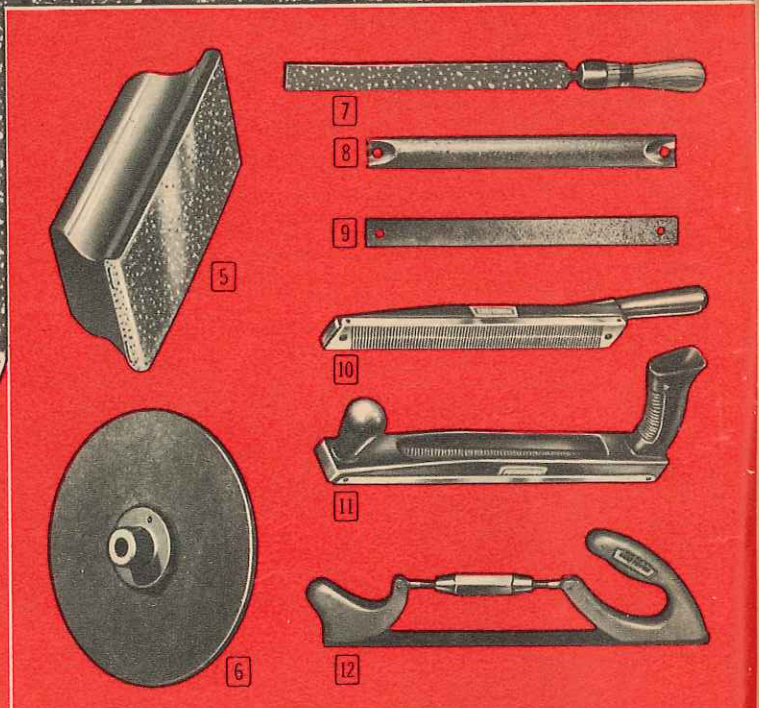
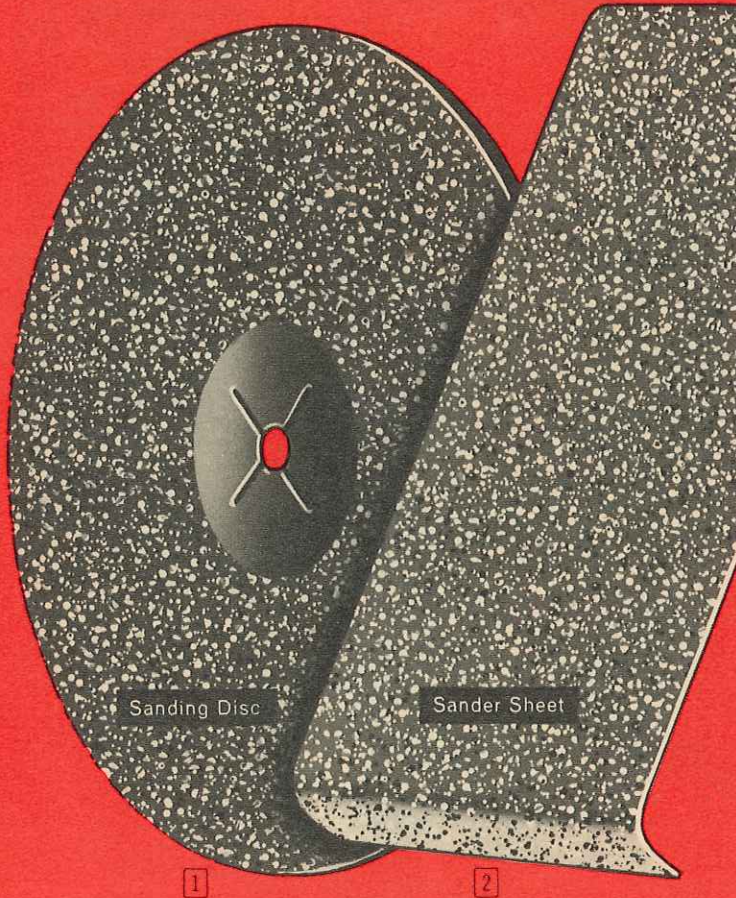
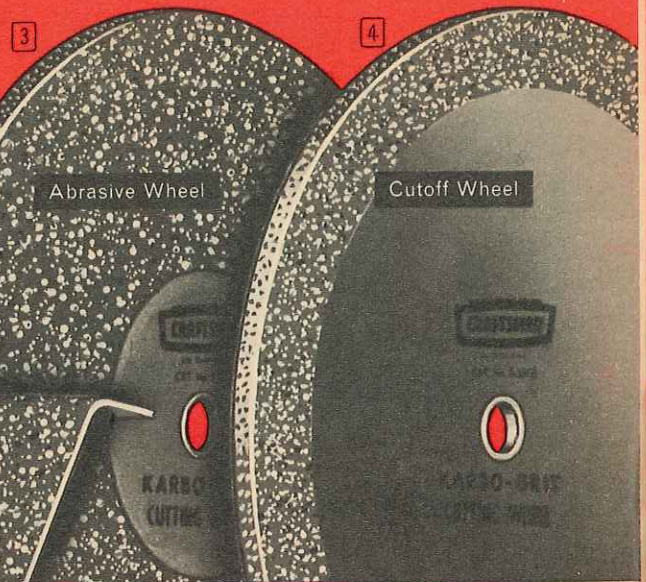

The hardest man-made abrasive; made possible by a new low-cost manufacturing process. Diamond-hard tungsten carbide grits brazed on steel. Very hard to wear out . . . stay sharp for years with normal use.

As long as the permanently-bonded grits last, these tools will both cut and smooth. If tools become clogged, they are easily cleaned with a wire brush or CRAFTSMAN Gum and Pitch Remover.

Electric Sander Sheets and Discs. Sand twice as fast as sandpaper, last up to 40 times longer. If sheets clog, lift sander off work; sanding motion shakes waste free. Wire brush or solvent remove paint or varnish.

State size, grit: fine, medium, coarse.

1 Sanding Discs. For rotary-motion sanders.
9 M 3007—5-in. diameter. Shipping weight 7 ounces. \$1.49
6-inch diameter. Shipping weight 10 oz. . . . 1.69

2 Sheets. For orbital or double arc sanders.
9 M 3004—2 3/4 x 8 inches. Shipping weight 5 ounces. . . . 98c
9 M 3005—3 3/4 x 9 inches. Shipping weight 7 oz. . . . \$1.49
9 M 3012—4 1/2 x 11 inches. Shipping weight 7 ounces. 1.98

- Make cuts ordinary saws can't do . . . saw, sand, dado, groove and plough
- Cut grooves for panels quickly . . . channel formed with one pass

3 Abrasive Wheel. Cuts and sands. For bench, radial saws. Coarse grits on one side and edge, medium grits on other side.
9 M 3000—*State blade diameter wanted.*
8-inch diameter. 3/8-1/2-in. round center hole. Shipping weight 2 pounds 10 ounces. . . . \$4.98
10-inch diameter. 3/4-5/8-in. round center hole. Shipping weight 4 pounds 2 ounces. . . . 6.49

4 Cutoff Wheel. Coarse grits on both sides and edge cut smoothly, quickly. Recommended for use on electric hand saws.
9 M 3008—*State blade diameter wanted.*
6 1/2-in. diam. 3/8-1/2-in. bushed round center hole. Shipping weight 1 pound 4 ounces. . . . \$3.69
7 1/2-in. diam. 3/8-1/2-in. bushed round center hole. Shipping weight 1 pound 9 ounces. . . . 3.98
8-in. diam. For bench saws. 3/8-1/2-in. bushed round center hole. Shpg. wt. 2 lbs. 10 oz. . . . 4.49
10-in. diam. 3/4-5/8-in. bushed round center hole. Shipping weight 4 pounds 2 ounces. . . . 5.98

5 Hand Sander. Karbo-Grits on thin steel backing. Far outlast sandpaper sheets. Excellent for sanding dry wall joints; won't clog with plaster. 2 3/4 x 5 1/2-inch sanding surface with felt back-up pad. *State grits wanted:* medium or fine.
9 M 3002—Shipping weight 11 ounces. . . . \$1.49

6 9-inch Sanding Disc. Fits belt and disc sander 9M2250, page 24. Coarse grits on one side for fast material removal, fine grits on other side for light sanding. Removable hub with hex head cap screws. Fits 3/8-inch shaft.
9 M 3013—Shpg. wt. 4 lbs. 2 oz. . . . \$6.98

7 Woodworking Files. Remove wood twice as fast as ordinary files. Cut on both forward and back strokes. Wide-spaced grits give blades a self-cleaning action, 10 in. long. Wood handle.
9 M 3001—Flat Blade, Medium and coarse sides. Shipping weight 13 ounces. . . . \$1.98
9 M 3003—Half-round Blade. 3/4-inch radius. *State grit:* medium or coarse. Shipping weight 12 ounces. . . . \$1.98

8 Rasplane Blades. Far outlast ordinary woodworking files. Fit Rasplane holders 9M6771 and 9M6770 below. *State grit wanted:* medium or coarse.
9 M 3016—Flat Blade. Shpg. wt. 4 oz. . . . \$1.29
9 M 3006—Half-round Blade. Wt. 4 oz. . . . 1.29

9 Flexible File Blade. Does outstanding job on car bodies. Fits file holder 9M3113 below. *State grit:* fine, med., coarse.
9 M 3009—Shipping weight 12 ounces. . . . \$1.98

10 11 Craftsman Rasplane Tools. Smooth soft metals, plastics, leather and wood. Kromedge blade, 2 rows of keenedged cutting louvers. Holders also fit blades 9 M 3016, 9 M 3006 above.
9 M 6771—File Type. (10) Wt. 12 oz. . . . \$2.39
9 M 6770—Plane Type. (11) Wt. 1 lb. . . . 2.69
9 M 6773—Flat Replacement Blade. Wt. 4 oz. . . . 79c
9 M 6774—Half-round Blade. Wt. 4 oz. . . . 79c

12 Craftsman Adjustable File Holder. Fits flexible file blade 9M3009 above. Adjusts for concave, convex or straight filing. Die-cast aluminum. With screws.
9 M 3113—Without blade. Wt. 1 lb. 13 oz. . . . \$5.29

FOR SEARS EASY TERMS see inside back cover

Aluminum Oxide Discs . . cut faster, outlast ordinary sandpaper



1 2



3

Remove excessive wood or finish—sand wood for staining or varnishing. Grind down most plastic and metal surfaces, remove rust and polish metal for painting. Open coat removes paint and varnish.

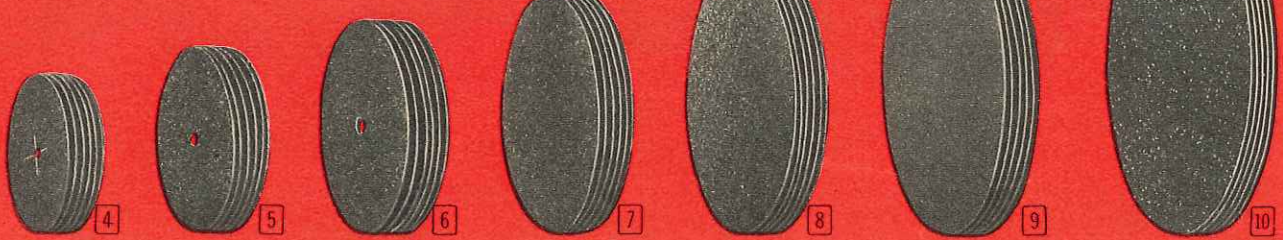

Aluminum Oxide Paper-back Discs.

- Costs less to complete a job with aluminum oxide . . . tough grits outlast most other abrasives
- Make short work of stock removal, finish sanding . . . grit edges are sharp, durable, fast-cutting

Penetrates high-carbon steels, steel alloys, bronze and other metals. Also perfect abrasive for repairing or smoothing fiberglass surfaces.

Fine grits prepare surfaces for finish sanding, medium and coarse grits remove stock rapidly. Aluminum oxide widely accepted for its outstanding performance in wood-working, leatherworking and metalworking industries. Ideal for home repairmen and hobbyists. Use 6-in. diam. discs or smaller for electric hand drills. Discs should be slightly larger than the back-up pad. *If discs to be used on face plate, be sure to order cement* (listed below at left).

1 Stick Disc Cement. Holds sanding discs firmly to wood or metal sanding plates. Does not dry out . . . makes removal of worn-out discs easy. Weight of each cement stick 4 3/4 ounces.

9 M 2219—Shipping weight 6 ounces. 49c

2 Liquid Disc Cement. Fastens abrasive discs to metal plates. Sets quickly and holds disc firmly until replaced. Shipping weight 1 pound 2 ounces.

9 M 2535—1/2-pint bottle. 59c

3 Abrasive Disc Holder. Converts lathe to sander and polisher. 1 1/2-inch diameter, 1/4-inch shank.

9 M 2446—Shipping weight 5 ounces. 89c

Aluminum Oxide grits on paper-back discs (not wanted and type of grits (fine, medium, coarse, open gummed). State catalog number, number of discs coat or assorted grits).

Key number	Size Diameter	Fits plate Diameter	With center hole	Catalog number	Number of discs per package					Shpg. wt. per pkg.	Price per package
					Fine	Med.	Crse.	Op.Coat	Total		
4	4-inches. . .	4-inches. . .	Yes	9 M 2544. . .	2	2	2		6	4 oz.	39c
	5-inches. . .	4 1/2 to 5-in.		9 M 2543. . .	3	3			6	4 oz.	39c
	5-inches. . .	5-inches. . .		9 M 2542. . .			3		3	2 oz.	39c
5	6-inches. . .	6-inches. . .	Yes	9 M 2532. . .	6	6			6	5 oz.	49c
					6	6	4		6	7 oz.	49c
					2	2	2	3	3	6 oz.	49c
6	7-inches. . .	7-inches. . .	Yes	9 M 2531. . .	2	2	2		6	9 oz.	69c
					6	6			6	4 oz.	79c
7	8-inches. . .	8-inches. . .	No	9 M 2525. . .	6	6			6	7 oz.	79c
					5	5			5	8 oz.	79c
8	9-inches. . .	9-inches. . .	No	9 M 2526. . .	6	6			6	6 oz.	98c
					6	6	5		5	8 oz.	98c
9	10-inches. . .	10-inches. . .	No	9 M 2534. . .	6	6			6	9 oz.	\$1.29
					6	6	5		5	10 oz.	1.29
10	12-inches. . .	12-inches. . .	No	9 M 2549. . .	2	2			2	7 oz.	89c
					2	2	2		2	7 oz.	89c

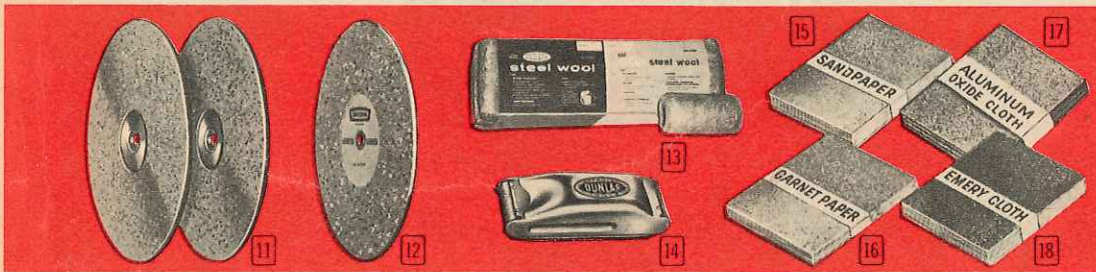

11 9 M 2272—10-inch diameter. Shipping weight 3 lbs. 12 oz. . . . \$2.98

12 9 M 2274—8-in. diam. Aluminum wheel; 1 side tapered for fine jointing. Shpg. wt. 1 lb. 3 oz. . . . \$2.98

13 Steel Wool. Grade 0 (fine): Cleans pots, pans. Takes paint spots off glass, tile. Puts gloss on waxed floors. Grade 1 (medium): Cleans white-wall tires. Takes tarnish off chrome, aluminum, copper, brass. Smooths wood for varnishing. Grades 2 and 3 (coarse): Remove rust, clean wood, asphalt, vinyl floors. State grade. Shipping weight 1 lb. 5 oz.

14 Dunlap Sanding Block. 6-in. steel block frame. With 30x1 5/8-inch roll of medium grit garnet paper. Pull out new section as paper wears out. 9 M 3681—Shipping weight 12 ounces. 89c

15 Flint Sandpaper. Regular low-priced sandpaper for general woodworking. 9x10-inch sheets. 9 M 6793—Please state grit wanted.

16 Garnet Paper. Thick back. Outlasts flint paper. Finishes wood before painting. 9x11-in. sheets. 9 M 6795—Please state grit wanted.

17 Aluminum Oxide Cloth. 9x11-in. sheets. Extremely tough, penetrates nearly all metals. 9 M 6789—State grit wanted.

18 Emery Cloth. 9x11-in. sheets. State grit: fine, med., coarse. 9 M 6798—Fine, Wt. 3 oz. . . 3 for 45c Medium, Shpg. wt. 3 oz. . . . 3 for 45c Coarse, Shpg. wt. 3 oz. . . . 3 for 45c

Grit	Shpg. wt.	12 for	Grit	Shpg. wt.	12 for
Extra fine	8 oz.	35c	Medium	12 oz.	35c
Fine	10 oz.	35c	Coarse	1 lb. 2 oz.	35c

Assorted Grits. Flint Sandpaper. 4 1/2 x 5-in. sheets. 9 M 6794—Shpg. wt. 5 oz. 20 sheets per package. . . 19c

Grit	Shpg. wt.	6 for	Grit	Shpg. wt.	6 for
Extra fine	6 oz.	65c	Medium	9 oz.	65c
Fine	7 oz.	65c	Coarse	15 oz.	65c

Garnet Finishing Paper. Thin back. 9x11-in. sheets. Finishes wood and metal before painting. Smooths before applying coats of paint or varnish. 9 M 3015—Package of 6. State grit wanted. 6/0 (Super fine.) Shipping weight 3 ounces. . . . 6 for 29c 4/0 (Extra fine.) Shipping weight 3 ounces. . . . 6 for 29c 2/0 (Medium fine.) Shipping weight 3 ounces. . . . 6 for 29c

Silicon Carbide Watersand Finishing Paper. 9x11-inch sheets. Use dry, with water or with rubbing oil. For fine, extra-smooth polishing of wood or metal. Package of 6 sheets. 9 M 3011—State grit wanted.

Assorted Grits of Silicon Carbide Watersand Finishing Paper. 4 1/2 x 5 1/2-inch sheets. Package of 10. 9 M 3010—Shpg. wt. 2 oz. 29c

Grit	Shpg. wt.	3 for
Fine	6 ounces	75c
Medium	6 ounces	75c
Coarse	6 ounces	75c

Emery Cloth. 9x11-in. sheets. State grit: fine, med., coarse. 9 M 6799—Shpg. wt. 4 oz. . . . Pkg. 19c

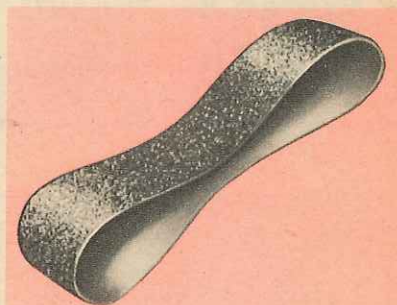

Sanding Belt

Sands wood, polishes metal. Tough, aluminum oxide grits on cloth belt. 1-piece construction.

4x36 in. Fits sander 99M2236C page 24 and other sanders of same size. State: fine, medium, coarse. 9 M 2215—Shipping weight 6 oz. . . . 89c

4x52 1/2 inches. State grit: fine, medium or coarse. 9 M 2211—Shpg. wt. 7 oz. 79c

6x48 in. State fine, med. or coarse. 9 M 2167—Shpg. wt. 11 oz. . . . \$1.49

3x27 in. For portable sander 99M2556C page 57, other sanders of same size. State grit. Wt. 4 oz. 9 M 2231—Extra fine; fine; medium; coarse. Each 49c 9 M 2231—Open coat. Each 75c

3x25 inches. For portable sander 99M25172C page 54, others of same size. State grit. Shpg. wt. 5 oz. 9 M 2232—Extra fine; fine; medium; coarse. 39c 9 M 2232—Open coat. 59c

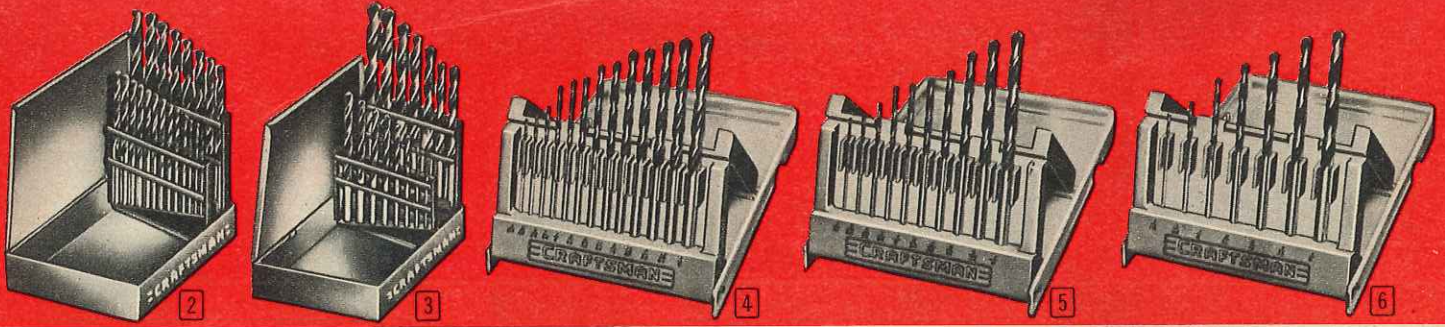

Super-strong CRAFTSMAN Drill Sets

REG. U.S. PAT. OFF.

For high-speed drilling of metal or wood

These fine, professional quality drills are precision ground to assure clean, accurate, easy cutting action in wood or metal.

Plastic cases marked for quick drill selection. Use only high speed bits for electric drills, drill presses and other power tools.

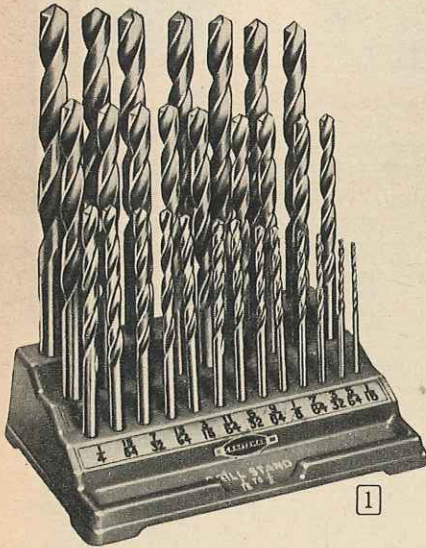

High-speed Steel Drill Sets in Drill Stands. Highest quality steels, expertly tempered and hardened. Precision-ground to exact size; cut cleanly and easily in wood or metal. Hole sizes are plainly marked on stand for convenience and easy selection. Use these drills for electric drills, drill presses and other power-driven tools.

1 CRAFTSMAN Set of 29 Drills. Professional quality, high-speed drills. $\frac{1}{16}$ to $\frac{1}{2}$ inch by 64ths. Shipping weight 3 pounds 2 ounces. 9 M 6704—\$3.00 down. Cash \$27.95

CRAFTSMAN Set of 60 Wire Gauge Drills. High speed drills for use in metal or wood. Cut with exceptional ease and accuracy. Includes all sizes from 1 to 60. Shipping weight 1 pound 6 ounces. 9 M 6707—\$2.00 down. Cash \$19.98

CRAFTSMAN High-Speed Twist Drill Sets. In handy metal folding cases. Professional-quality drills with high-speed steel construction, hardened and tempered. Precision ground for fast, clean, accurate cutting action in wood or metal. For use in electric drills, drill presses, and other power-driven tools. In compact, easy-to-carry metal cases. Each case contains two drill panels which fold into box like pages of a book. Each compartment marked with proper drill size and decimal inch equivalent, for convenience and ease of selection.

2 9 M 6719—21-piece Drill Set. Sizes $\frac{1}{16}$ to $\frac{3}{8}$ inch by 64ths. Shipping weight 2 pounds. \$15.79

3 9 M 6720—15-piece Drill Set. Sizes $\frac{1}{16}$ to $\frac{1}{2}$ inch by 32nds of an inch. Shipping weight 2 lbs. 6 oz. \$16.98

4 CRAFTSMAN 13-piece High-Speed Drill Set. For high-speed drilling in metal or wood. Use with any electric drill, drill press or other power tool. Comes in sizes: $\frac{1}{16}$, $\frac{5}{64}$, $\frac{3}{32}$, $\frac{7}{64}$, $\frac{1}{8}$, $\frac{9}{64}$, $\frac{5}{32}$, $\frac{11}{64}$, $\frac{3}{16}$, $\frac{13}{64}$, $\frac{1}{4}$. 9 M 6639—Shpg. wt. 12 oz. \$5.49

5 CRAFTSMAN 10-piece Drill Set. In sizes: $\frac{1}{16}$, $\frac{5}{64}$, $\frac{3}{32}$, $\frac{7}{64}$, $\frac{1}{8}$, $\frac{9}{64}$, $\frac{5}{32}$, $\frac{3}{16}$, $\frac{7}{32}$, $\frac{1}{4}$ in. Made of high speed steel; for use in wood or metal. Comes in plastic case. 9 M 6638—Shpg. wt. 10 oz. \$3.89

6 CRAFTSMAN 7-piece High Speed Drill Set. Can be used in cast iron, steel, and steel forgings. $\frac{1}{16}$, $\frac{3}{32}$, $\frac{1}{8}$, $\frac{5}{32}$, $\frac{3}{16}$, $\frac{1}{4}$ inch. For electric drills, drill presses, etc. 9 M 6637—In plastic case. Wt. 7 oz. \$2.98

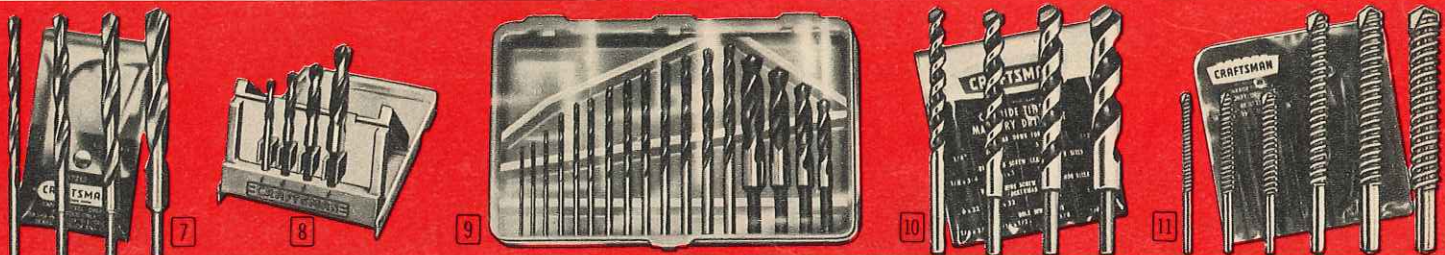

CRAFTSMAN Drill Sets specially designed to be used in your portable drills

7 4-piece Drill Set. For wood. Made of carbon steel; $\frac{1}{4}$ -inch shanks. Use with $\frac{1}{4}$ -inch drill. Sizes: $\frac{1}{8}$, $\frac{5}{16}$, $\frac{3}{8}$, $\frac{1}{2}$ inch. $5\frac{3}{16}$ inches long. In plastic case for convenient carrying. Shipping weight 7 oz. 9 M 67212. \$2.39

9 M 6717—Individual CRAFTSMAN Wood Drills: As in set above. Shipping weight 4 ounces. State size. $\frac{1}{4}$ inch 49c; $\frac{3}{8}$ inch 69c $\frac{1}{2}$ inch 89c; $\frac{5}{16}$ inch 55c; $\frac{1}{2}$ inch \$1.09

8 4-piece High Speed Drill Set. For drilling in metal or wood. Come in sizes: $\frac{1}{4}$, $\frac{5}{16}$, $\frac{3}{8}$, $\frac{1}{2}$ in. $\frac{1}{4}$ -in. round shanks. $2\frac{1}{2}$ to $3\frac{3}{4}$ in. long. Plastic case. 9 M 6636—Shpg. wt. 11 oz. \$4.79

Single CRAFTSMAN High Speed Drills. As above. $\frac{1}{4}$ -inch shanks. 9 M 66363—State size. Wt. ea. 3 oz. $\frac{1}{4}$ -in. $\frac{5}{16}$ -in. $\frac{3}{8}$ -in. $\frac{1}{2}$ -in. 65c \$1.09 \$1.39 \$1.89 \$2.29

CRAFTSMAN Large-Diameter High Speed Bits. Fit $\frac{1}{2}$ -in. electric drills, drill presses. 9 M 6715—State size wanted. Size. $\frac{3}{8}$ in. $\frac{1}{2}$ in. 1 in. Shpg. wt. 6 oz. 9 oz. 12 oz. Each. \$5.49 \$7.29 \$10.59

9 17-piece High Speed Drill Set. For drilling in wood or metal. Use with $\frac{1}{4}$ -inch electric drills. Sizes included are: $\frac{1}{16}$, $\frac{5}{64}$, $\frac{3}{32}$, $\frac{7}{64}$, $\frac{1}{8}$, $\frac{9}{64}$, $\frac{5}{32}$, $\frac{3}{16}$, $\frac{7}{32}$, $\frac{1}{4}$, $\frac{5}{16}$, $\frac{3}{8}$, $\frac{1}{2}$ and $\frac{5}{8}$ inch. Sizes larger than $\frac{1}{4}$ inch have shanks narrowed to $\frac{1}{4}$ inch to fit drill. In handy plastic storage case whose transparent top lets you choose drills quickly. Shipping weight 1 pound. 9 M 6711. \$10.98

10 Carbide-tipped Masonry Drills . . . with spiral flutes. Drill to 3-in. depth. 9 M 6747—4-piece set. One each of 4-in. sizes below. In plastic case. Shipping weight 6 ounces. \$4.49

9 M 6746—Individual Drills. Case not included. State size.

Size	Shank	Length	Shpg. wt.	Each
$\frac{1}{4}$ in.	$\frac{1}{4}$ in.	4 in.	1 oz.	98c
$\frac{5}{16}$ in.	$\frac{1}{4}$ in.	4 in.	1 oz.	\$1.09
$\frac{3}{8}$ in.	$\frac{1}{4}$ in.	4 in.	2 oz.	1.29
$\frac{1}{2}$ in.	$\frac{1}{4}$ in.	4 in.	3 oz.	1.59
$\frac{1}{2}$ in.	$\frac{3}{8}$ in.	6 in.	5 oz.	1.98
$\frac{3}{4}$ in.	$\frac{1}{2}$ in.	6 in.	8 oz.	2.49
$\frac{1}{2}$ in.	$\frac{1}{2}$ in.	6 in.	10 oz.	2.98
$\frac{1}{2}$ in.	$\frac{1}{2}$ in.	6 in.	12 oz.	3.98
$\frac{1}{2}$ in.	$\frac{1}{2}$ in.	6 in.	15 oz.	4.89

11 Our Best Carbide-tipped Masonry Drills. Screw-type flutes clean out drilled holes. Tungsten carbide tips . . . hardest metal made by man! Set of 6. One each, sizes $\frac{1}{4}$ to $\frac{3}{4}$ in. under 9M6730 below. In case. Wt. 1 lb. 11 oz. 9 M 6731. Set of 6 for \$11.49

9 M 6730—Individual Sizes. Please state size wanted from table below.

Size	Shank	Length	Shpg. wt.	Each
$\frac{3}{16}$ in.	$\frac{3}{16}$ in.	3 in.2 oz.	\$1.19
$\frac{1}{4}$ in.	$\frac{3}{16}$ in.	4 in.2 oz.	1.29
$\frac{5}{16}$ in.	$\frac{1}{4}$ in.	4 in.4 oz.	1.39
$\frac{3}{8}$ in.	$\frac{1}{4}$ in.	4 in.4 oz.	1.49
$\frac{1}{2}$ in.	$\frac{3}{8}$ in.	6 in.6 oz.	1.98
$\frac{5}{8}$ in.	$\frac{1}{2}$ in.	6 in.	1.0 oz.	2.49
$\frac{3}{4}$ in.	$\frac{1}{2}$ in.	6 in.	1.2 oz.	3.29



6-pc. Rotary Cutter Set

12 CRAFTSMAN. High-speed steel cutters: $\frac{1}{4}$ -inch diameter shanks. Use with flexible shafts, drills, etc. For wood, plastics and metal (except hardened steel). Set includes one each of cutters listed below. Buy the set of six and save \$1.76. Separate prices total \$9.74. 9 M 2965—Wt. 6 oz. Set \$7.98

Rotary Cutters. Shipping weight each 3 ounces.

9 M 2970— $\frac{3}{8}$ -inch Tree-shaped (pointed end) \$1.89

9 M 2967— $\frac{1}{4}$ -inch Spherical 1.49

9 M 2966— $\frac{1}{4}$ -inch Cylindrical 1.49

9 M 2968— $\frac{3}{8}$ -inch Elliptical 1.89

9 M 2971— $\frac{1}{4}$ -inch Conical 1.49

9 M 2969— $\frac{1}{4}$ -inch Tree-shaped (radius end) 1.49



Mounted Grinding Points. Vitrified aluminum oxide, dressed and true. For finishing, die cutting, etc. Use with hand grinder (9M2597, page 38), etc. $\frac{1}{4}$ -in. steel shafts. Use in collet-type chucks. Sizes are stone sizes. Shpg. wt. ea. 3 oz.

Catalog Number	Diameter	Length	Each
(13) 9 M 6461	$\frac{3}{8}$ inch	2 $\frac{1}{2}$ inches65c
(14) 9 M 6462	$\frac{1}{2}$ inch	2 inches65c
(15) 9 M 6462	$\frac{3}{8}$ inch	2 inches65c
(16) 9 M 6459	1-in. ball65c
(17) 9 M 6457	$\frac{3}{8}$ inch	1 $\frac{1}{2}$ inches65c
(18) 9 M 6443	1 inch	$\frac{3}{8}$ inches65c
(19) 9 M 6458	$\frac{1}{16}$ inch	$\frac{3}{8}$ inches65c
(20) 9 M 6460	1 inch	1 inch65c
(21) 9 M 6444	$\frac{1}{2}$ inches	$\frac{1}{2}$ inch65c

22 CRAFTSMAN Power Countersink. For wood and non-ferrous metals. Adapted for high speed application in drill presses and electric drills; rugged, dependable and long-lasting.

Will accommodate full range of screw sizes. $\frac{1}{4}$ -inch shank for use in $\frac{1}{4}$ -inch drills. Size of head $\frac{3}{8}$ inch. Shipping weight 4 ounces. 9 M 4205. 45c

Add versatility to your shaper table or drill press! Shaper-cutters make cuts shown below and at right.

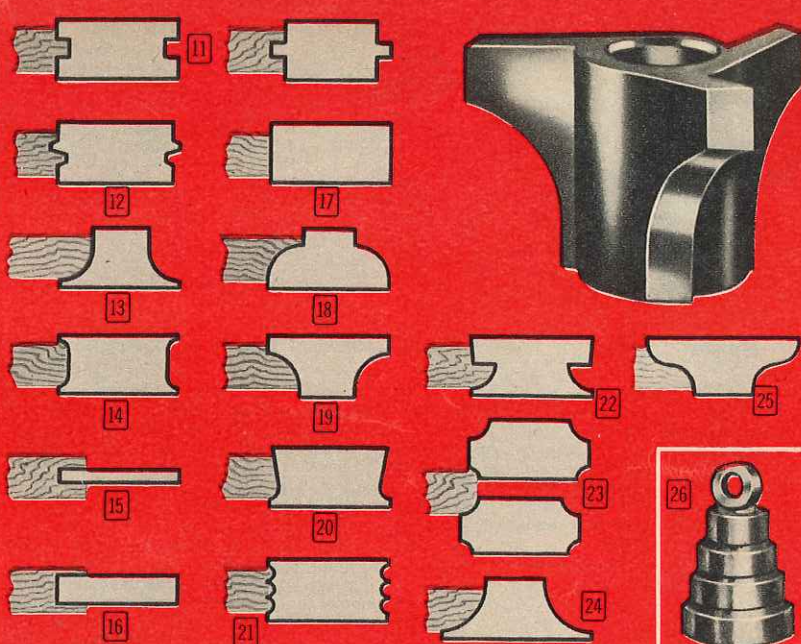
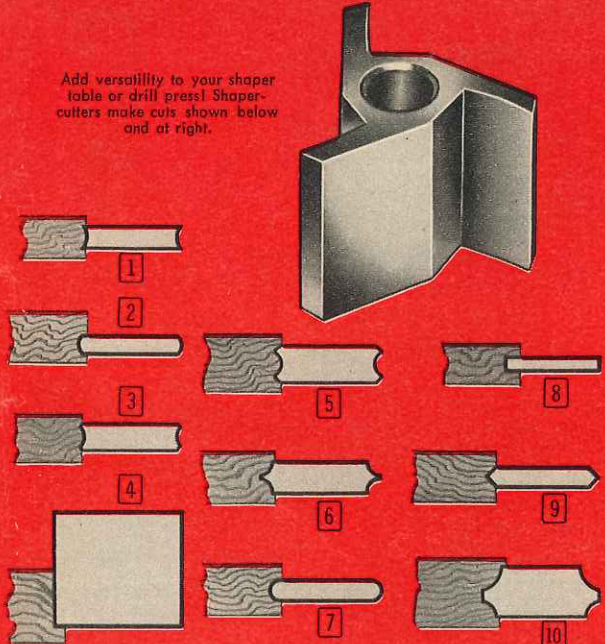

5/16-inch Bore Shaper-Cutters

Kromedge Cutters. Use with CRAFTSMAN Shaper table 99M25157 (page 55), or can be used on drill press with collet or safe lock chuck with 9M2550 adapter (below). Specially hardened alloy steel. Shipping weight, each cutter, 2 ounces. Price each.....\$1.98

	Catalog Number	Width of cut, in.	Radius of cut, in.	Type of cutter
1	9 M 2516	1/16	1/8	concave
	9 M 25161	1/8	3/16	concave
	9 M 25162	3/16	1/4	concave
	9 M 25163	1/4	3/8	concave
2	9 M 2519	1/16	1/8	convex
	9 M 25191	1/8	3/16	convex
	9 M 25192	3/16	1/4	convex
	9 M 25193	1/4	3/8	convex
3	9 M 2523	3/16	1/8	corner bead
	9 M 25231	1/4	3/16	corner bead

	Catalog Number	Width of cut, in.	Radius of cut, in.	Type of cutter
5	9 M 2540	1/16	3/32	surface bead
	9 M 25401	3/32	1/8	surface bead
6	9 M 2538	3/32	1/8	spindle bead
	9 M 25381	1/32	3/32	spindle bead
7	9 M 2561	3/16	3/32	flute
	9 M 25612	1/8	1/8	flute
8	9 M 2575	1/8		straight face
	9 M 25751	3/32		straight face
	9 M 25752	1/4		straight face
	9 M 25753	3/8		straight face
9	9 M 2577	1/16		"V" flute
	9 M 25771	3/32		"V" flute

4 Wide Straight Face Cutter. Makes flat cut one inch wide.
9 M 25754—Shipping weight 2 ounces. .\$.29
Set of 6 Depth Collars . . . For Shaper Table Attachment 99 M 25157 (page 55).
9 M 2550—Shipping weight 5 ounces. .\$.149

10 Combination 1/8 and 3/16-inch Quarter Round Shaper Cutter. Makes cut 1/16 inch wide; cuts quarter round grooves parallel to each other in material. Shipping weight 2 ounces.
9 M 2579.....\$1.98

1/2-inch Bore Shaper-Cutters

Made of special alloy steel. All cutters 1 inch high, with 1/2-inch bore, except 9 M 3287 (3/4 inch high); 9 M 3288 (1/2 inch high). For use with drill press, use adapter 9 M 2483 below. Cutters precision-machined.

- 2-inch Diameter Shaper-Cutters
- 11 9 M 3283—Matched set of 1/4-in. Tongue and Groove. Shipping weight 5 ounces. .\$.549
 - 12 9 M 3284—Reversible Glue Joint. Wt. 3 oz. . 2.98
 - 13 9 M 3285—1/2-in. Radius Base Shoe Molding or 1/2-in. Quarter Round. Shipping wt. 3 oz. . \$2.98
 - 14 9 M 3286—1/8-in. Radius Ease Edge or Screen Mold. Shipping weight 3 ounces. . .\$.2.98
 - 15 9 M 3287—1/4-inch Groove. Shpg. wt. 3 oz. . . 2.69
 - 16 9 M 3288—1/2-inch Groove. Shpg. wt. 3 oz. . . 2.69
 - 17 9 M 3289—1-inch Jointer. Shpg. wt. 3 oz. . . . 2.98
 - 18 9 M 3290—Drop Leaf Cove. Shpg. wt. 3 oz. . . . 2.98
 - 19 9 M 3291—Drop Leaf Bead. Shpg. wt. 3 oz. . . . 2.98
 - 20 9 M 3292—Taper Edge. Shipping wt. 3 oz. . . . 2.98
 - 21 9 M 3293—3-bead 3/4 inch Molding. Wt. 3 oz. . . . 2.98
 - 22 9 M 3294—Lip Cupboard Door or 3/8-inch Quarter Round. Shipping weight 3 ounces. . .\$.2.98
 - 23 9 M 3295—1/8 and 1/4-inch radius Ease Edge or 1/4-inch Glass Bead. Shipping weight 3 ounces. . .\$.2.98

- 2 1/2-inch Diameter Shaper-Cutters
- 24 9 M 3281—3/4-inch Quarter-Round Shaper-Cutter. Made of special alloy steel. Shipping wt. 5 oz. \$3.98
 - 25 9 M 3282—3/4-inch Ogee Molding Shaper-Cutter. Special alloy steel. Wt. 5 oz. \$3.98
 - 26 Set of 5 Shaper Collars. Mount beneath cutters to control depth of cut. Made of alloy steel for long wear. Fits 1/2-inch spindle. Shipping weight 6 oz. \$2.49
- Guaranteed against defects in materials, workmanship

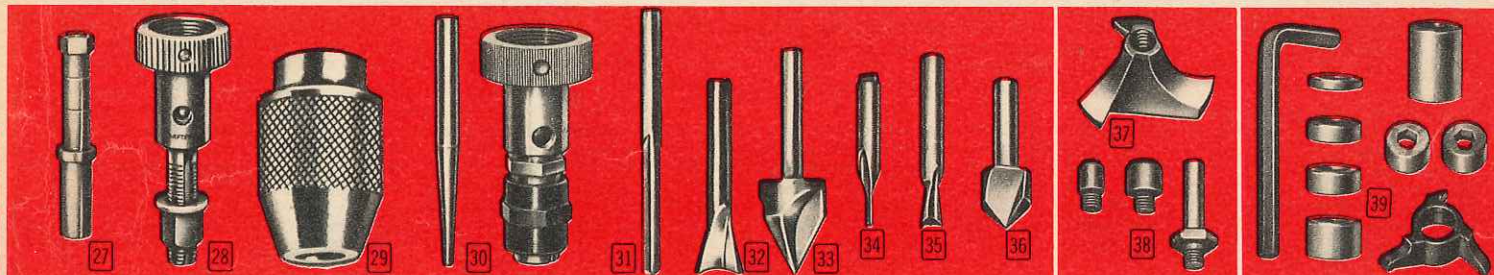

Adapters, Chucks, Cutters and Bits for shaping wood with routers, drill presses

- 27 Spindle Adapter. For use with 5/16-inch cutters above. Permits use of shaper-cutters with any drill press. Shipping weight 4 ounces.
9 M 2550.....\$1.49
- 28 Adapter with Holding Collar. For all 1/2-inch bore shaper-cutters above. Fits 99 M 2452N, 99 M 2453N, and 99 M 2362N (page 31); or any drill press with Number 33 Jacobs tapered spindle. Adapter has 1/2-inch x 20 thread and holding collar to screw on drill press. Shipping weight 10 ounces.
9 M 2483.....\$2.39
- 29 Screw-on type Collet Chuck. Use with routing, dovetailing, carving bits. Fits any 1/2-inch x 20-thread spindle. Can be used with 9 M 2483 adapter at left. Shipping weight 3 ounces.
9 M 2271—1/4-in. cap. .\$.1.29
9 M 2269—1/2-in. cap. . . 1.59
- 30 Collet Chuck with Holding Collar. For high-speed woodworking bits listed at right, or any 1/4-in. or 3/8-in. diameter shank. 1/2-inch capacity with 1/4-inch bushing. Fits any drill press with No. 33 Jacobs taper spindle. With holding collar that screws right on drill press. Replaces three-jaw chucks for any work developing side thrust, such as routing or carving. Shipping weight 11 ounces.
9 M 2467.....\$2.39

High Speed Woodworking Cutters. With 1/4-inch shanks. Precision-ground, high carbon steel. For use in drill presses, etc. For carving, dovetailing, edging, and routing. Fit "Safe-Lock" chucks, and 9 M 2467 or 9 M 2271 collet chucks described at left.
CAUTION: Use these cutters only with threaded collar chucks or collet chuck 9M2467. Use fence and hold-down when working with drill presses. Shpg. wt. each 2 oz.

- 31 9 M 2400—1/8-in. router. .\$.1.39
- 9 M 2401—1/4-in. router. 1.49
- 9 M 2402—3/8-in. router. 1.59
- 9 M 2403—1/2-in. router. 1.79
- 9 M 2404—3/4-in. router. 1.98
- 9 M 2410—3/8-in. dovetail 1.59
- 9 M 2411—1/2-in. dovetail 1.79
- 9 M 2415—1/2-in. carving. 1.79
- 9 M 2416—3/4-in. carving. 1.98

All shapers, bits and accessories guaranteed against defects in materials or workmanship

- Bits for power router. 1/4-inch diameter shanks. Fits 9M25589 (page 54), or 9 M 2508 (see page 53). Fits drill presses. Fit Stanley, Porter Cable, Skil routers.
- | Cat. No. | Size | Shpg. wt. | Each |
|--------------------------------|------------|-----------|--------|
| 34 Straight Face Router Bits. | | | |
| 9M2552 | 1/8 in. | 3 oz. | \$1.49 |
| 9M25521 | 1/4 in. | 3 oz. | 1.49 |
| 9M25522 | 3/8 in. | 3 oz. | 1.98 |
| 9M25523 | 1/2 in. | 2 oz. | 2.49 |
| 34 Stair Routing Bit. | 1 1/16 in. | 2 oz. | 3.49 |
| 34 Veining Bits. | | | |
| 9M2559 | 1/8 in. | 2 oz. | 1.59 |
| 9M25592 | 3/16 in. | 2 oz. | 1.69 |
| 9M25593 | 1/2 in. | 2 oz. | 1.79 |
| 35 Dovetail Cutter Bits. | | | |
| 9M2553 | 1/4 in. | 2 oz. | 2.98 |
| 9M25531 | 1/2 in. | 2 oz. | 3.98 |
| 35 V-Groove or Chamfering Bit. | | | |
| 9M2557 | 1/2 in. | 2 oz. | \$3.98 |

Bits and Pilots; Sash Cutter Kit

- 37 1/2-inch Bead Bit. For use with (38) Pilots and Arbor listed below.
9 M 25541—Shipping weight 3 ounces. . .\$.3.49
- 37 3/8-inch Bead Bit. For use with (38) Pilots and Arbor listed below.
9 M 25542—Shipping weight 3 ounces. . .\$.3.49
- 37 1/2-inch Cove Bit. For use with (38) Pilots and Arbor listed below.
9 M 25543—Shipping weight 4 ounces. . .\$.3.49
- 37 3/8-inch Cove Bit. For use with (38) Pilots and Arbor listed below.
9 M 25544—Shipping weight 3 ounces. . .\$.3.49
- 38 Two Pilots with 1/4-in. x 28-thread Arbor. For use with bead and cove bits (37) above.
9 M 2589—Shipping weight 2 ounces. . .\$.1.98
- 39 Sash and Door Cutting Kit. Fits 99 M 2392N Shaper (see page 23) and former Shaper 2381. Kit includes 5 spring collars (1/8, 1/4, 5/16, 3/8 and 1 inch wide) with 1/2-inch bore; sash cutter blade. Also, includes Allen wrench; 3 recessed nuts (1/2x24, 1/2x20 and 1/2-inch x 16-inch thread). For best results, use kit with Adapter 9 M 2483 (at left).
9 M 2407—Shipping weight 8 ounces. . .\$.3.98

EASY TERMS . . Buy all your tools on Easy Terms . . see inside back cover

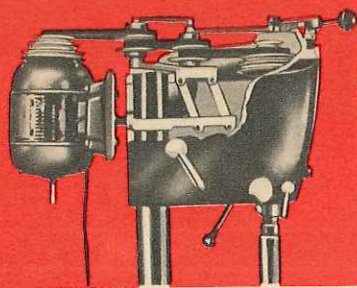

Speed Changer

Select any speed from 300 to 3750 RPM without stopping the spindle! The only drill press attachment we know of that gives a 12 to 1 ratio with just one hand lever, without changing belts. Saves drills . . . time. For use with CRAFTSMAN "150" Drill Presses listed on facing page.

Vari-Slo Speed Control mounts right on drill press column. No holes to drill or tap. Made of tough aluminum alloy and cast Tenzaloy. Pulleys mounted on 4 grease-sealed precision ball bearings; lubricated for life. All steel parts plated to resist rust. With three V-belts, set screw wrench and instructions.

9 M 2340—Wt. 5 lbs. 4 oz. . . \$38.50

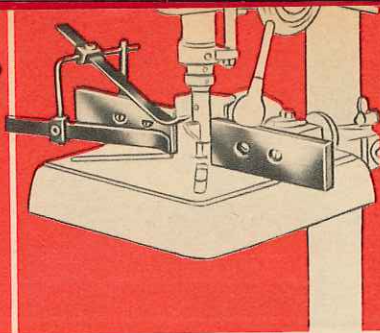

Drill Press Shaper Fence and Dovetail Attachments

Converts your drill press into a shaper! Ideal for the home craftsman who has limited use for a separate shaper. Fence gives support necessary in making picture frames, sashes, moldings and trimmings. For use with Drill Presses listed on facing page.

Unit fastens to drill press table with bolts. Once installed, it can be left undisturbed during operation adjustments. Fence faces of hardwood, each $6\frac{3}{4} \times 2\frac{1}{2}$ in., have separate finger-tip micrometer type adjustments with $1\frac{1}{8}$ -in. maximum forward and back travel; and open from 1 in. for smallest diameter shaper cutter to 3-in. maximum for large cutters and sanding drums. Fence faces planed to within .005-in. accuracy after assembly of unit. One-piece cast aluminum has opening in back for chip outlet. Adjustable steel hold-downs maintain constant pressure on work; one-screw locks . . . no chatter or jumping. Hold-down assembly shifts quickly to either end of unit for regular or reverse feeding. Cutters and attachments not incl. . . see page 13.

9 M 2487—Shipping weight 6 pounds 2 ounces. \$14.98

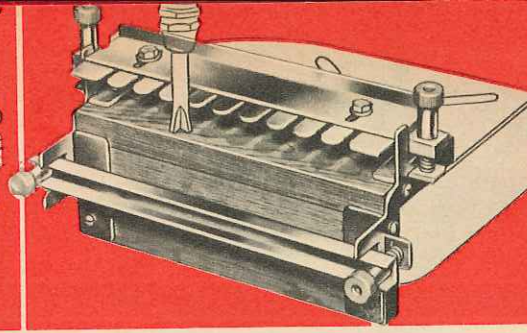

Cut square holes

Do away with tedious chisel mortising forever . . . your drill press can do a fast, clean job with a CRAFTSMAN Mortising Chisel. Housing mounts on quill. Bit drills round hole; hollow chisel trims corners perfectly square. Speeds up cabinet work . . . perfect fits.

1 Mortising Chisel Housing. For use with CRAFTSMAN "150" Drill Presses listed on facing page. 9 M 2460—Shpg. wt. 3 lbs. 6 oz. \$4.98

2 Hollow Chisel. State size: $\frac{1}{4}$, $\frac{3}{8}$ and $\frac{1}{2}$ inch. 9 M 2420—Shpg. wt. 4 oz. Each \$2.98

3 Mortising Bit. State size: $\frac{1}{4}$, $\frac{3}{8}$ or $\frac{1}{2}$ inch. 9 M 2422—Shpg. wt. 4 oz. Each \$1.98

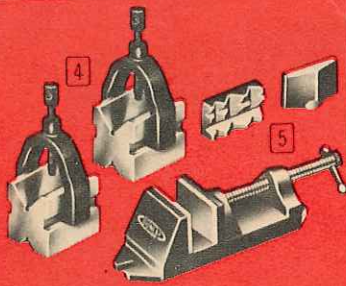

4 CRAFTSMAN V-blocks and clamps. Two cast-iron $2 \times 1\frac{1}{2} \times 1\frac{1}{2}$ -inch V-blocks; two malleable iron clamps. Hold rods up to 1 $\frac{1}{2}$ inches diameter. Hold round, irregular work on table.

9 M 40824—Wt. 2 lbs. 7 oz. . . . \$6.29

5 DUNLAP Drill Press Vise. Cast non-ferrous metal base. $2\frac{3}{8}$ -inch jaws with steel faces open 3 inches. $10\frac{1}{2}$ inches long over-all. With extra cast-iron jaws; one for round or irregular work; one for tapered pieces.

9 M 2436—Shpg. wt. 4 lbs. . . . \$4.89

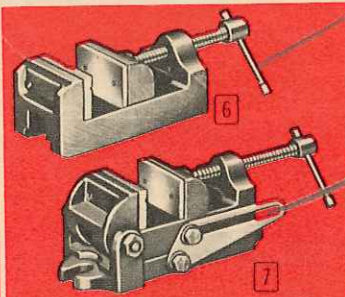

6 CRAFTSMAN Drill Press Vise. Precision-squared sides for use on end, on either side, or in normal horizontal position. Can be used with magnetic chuck. Machined cast iron; rust-resistant finish. Steel adjusting screws; fine pitch thread and long bearing in vise. $2\frac{1}{16}$ -inch steel jaws. Holds round, oval or tapered pieces; opens to $2\frac{1}{2}$ inches, $7\frac{1}{4}$ inches long.

9 M 2755—Shipping weight 4 pounds 12 ounces. \$7.49

7 CRAFTSMAN Drill Press Angle Vise. Quick accurate set-ups without use of clamps or wedges. Adjusts 0° to 90°, or used horizontally. Can be used with magnetic chuck. Steel adjusting screws. Fine pitch thread; long bearing in vise body. $2\frac{1}{16}$ -in. jaws open to $2\frac{1}{2}$ in. 9 in. long over-all. Jaws hold round or tapered pieces.

9 M 2756—Shipping weight 9 pounds 12 ounces. \$9.79

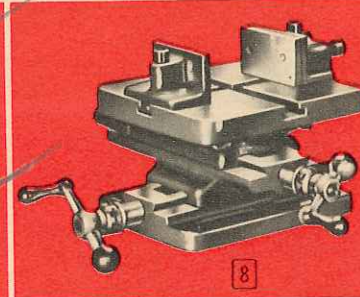

8 Drill Press Milling Vise. Bolts to drill press table . . . also adapts to shapers, lathes, milling machines and grinders. Work is locked on 7x7-inch table between adjustable jaws. ($4\frac{1}{2}$ -inch maximum opening). One jaw swivels, other has movable face. $6\frac{1}{2}$ -inch cross feed travel (lower) $5\frac{1}{2}$ -inch traverse feed travel (upper). Upper slide graduated 90° right or left. Comes with wrench, bolts.

99 M 2432K—Shpg. wt. 35 lbs. \$5 down, \$5.00 monthly. Cash \$49.95

9 CRAFTSMAN Milling Vise. Dual cross slides; 360° rotary feed. Use as indexing, rotary, milling tables. For drill presses, milling machines, surface grinders or shapers. 8-in. table rotates 360°; 40:1 worm gear ratio. Rotary dial calibrated in 15-minute intervals. Dual cross feed $2\frac{1}{2}$ in. each side or $2\frac{1}{4}$ in. over-all. Dials in 1000ths. With removable jaw set $2\frac{1}{2}$ in. wide. Table 5 in. high.

99 M 2496K—Shpg. wt. 37 lbs. \$5.00 down, \$5.00 monthly. Cash \$69.50

99 M 2493K—As above, but without rotary feed. Has dual cross feed arrangement. Shpg. wt. 35 lbs. \$5.00 down, \$5.00 monthly. Cash \$49.95

Drill Press Clamps and Vises are like extra hands in your shop

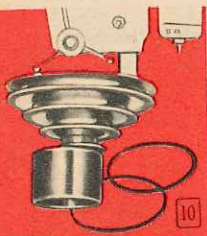

10 CRAFTSMAN Slow-Speed Attachment. Speeds from 210 to 9800 RPM. Low speeds for heavy metal work . . . higher speeds for shaping, routing, etc. For metal drilling even with $\frac{1}{2}$ -in. drill. Base fits inside column. Pulley runs on large double-row ball bearings. 4-step, cone-type pulley. 2 V-belts incl. Use with $\frac{1}{2}$ -HP 1725 RPM motor (minimum). See Vari-Slo speed control above. Use with CRAFTSMAN "150" Drill Presses on facing page, and all drill presses with 2 or $2\frac{3}{8}$ -in. (plus .005-in.) inside diam.

9 M 2338—Shipping weight 4 pounds 5 ounces. . . \$15.49

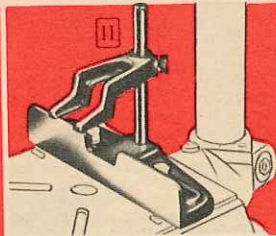

11 CRAFTSMAN Hold-down and Guide. Fits almost any drill press table. For mortising, routing, planing or repetitive drilling. Fingers on hold-down prevent work from being lifted when chisel or drill is raised. Adjustable for thick or thin materials. Fence keeps work lined up. Bolts to table.

9 M 2457—Shipping weight 5 lbs. 8 oz. \$6.29

12 CRAFTSMAN Rotary Planer. Fits drill presses having No. 33 Jacobs taper and $1\frac{1}{16}$ -in. x 20-threaded side thrust nut or locking collar. Diam. $3\frac{3}{8}$ in. Allen wrench.

9 M 2745—Shipping weight 12 ounces. \$4.98

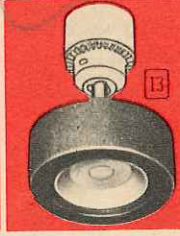

13 CRAFTSMAN Sanding Drums. For drill presses, flexible shafts, electric drills, etc. 1-in. faces; $\frac{1}{4}$ -in. plain spindle, $1\frac{1}{2}$ in. long. Use with collet or lock type chuck.

9 M 2497— $1\frac{1}{2}$ -inch diameter. Shipping weight 5 ounces. Each \$1.09

9 M 2498— $2\frac{1}{16}$ -inch diameter. Shipping weight 6 ounces. Each 1.19

9 M 2499—3-inch diameter. Shipping weight 9 ounces. Each 1.39

9 M 2442—Sanding Drum Sleeves. For drums above. State diam. and fine, med. or coarse grit. Wt. 3 oz. Pkg. of 6 for 49c

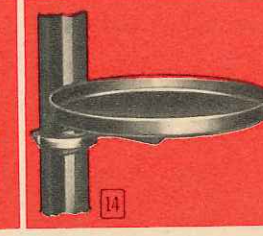

14 12-in. Drill Press Tool Tray. Wt. 4 lbs. 8 oz.

9 M 2459. \$4.19

16 CRAFTSMAN Heavy-Duty Circle Cutter. $\frac{1}{2}$ -in. shank. 2 to 8-in. diam. holes. Wt. 1 lb. 2 oz.

9 M 3641. \$4.98

CRAFTSMAN Circle Cutter. Combination sq. and $\frac{1}{4}$ -in. round shank. Holes from $\frac{7}{8}$ to 4-in. diam.

9 M 3644—Wt. 8 oz. . . \$1.89

Our finest! CRAFTSMAN

REG. U. S. PAT. OFF.

"150" Drill Presses

100-sq. in. table gives lots of work space

Look at what a drill press can do for you . . .

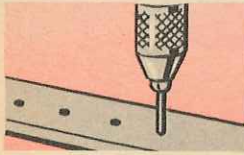

Repetitive drilling

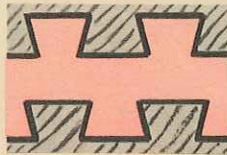

Dovetailing



Mortising



Shaping



Routing

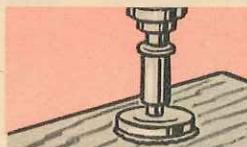

Planing

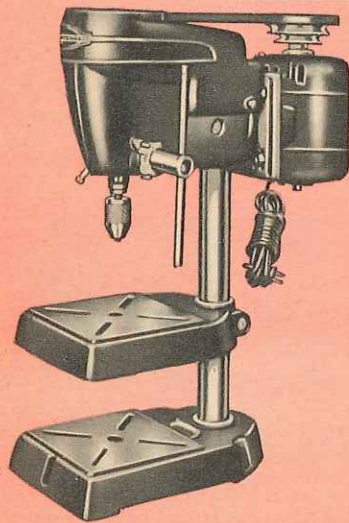

DUNLAP Model Maker Drill Press

Over 60 square inches of table area

Without motor **\$64.50** \$5 cash down

Heaviest drill press we know of in this price range! 6½-in. depth of throat . . . drills to center of 12¼-in. circle. 3 porous bronze bearings; ball thrust bearing absorbs spindle thrust. "Floating drive" spindle eliminates side pull of belt and pulley "whip." Adjustable stop collars for repetitive drilling. "Perma-Coil" quill return spring. Rubber shock cushion.

Maximum spindle travel is 3 in. Depth gauge graduated in 16ths of an inch. No. 33 Jacobs taper spindle with "Safe-Lock" key chuck (¾ to ½-in. capacity). 7¼x7¼-in. table; does not tilt. Table travel 7¼ in.

4-in. four-step pulleys give 9 speeds (765 to 4000 RPM). Pulleys and V-belt incl. Minimum of ½-HP, 1725 RPM motor recommended. Height 26⅞ in.; width 10⅞ in.; depth 15½ in.

99 M 2362N—Drill press without motor. Shpg. wt. 80 lbs. \$64.50

99 M 23625N2—With CRAFTSMAN ½-HP 1725 RPM motor for 110-120-volt, 60-cycle AC. Shpg. wt. 106 lbs. \$77.50

SPECIFICATIONS

Detail	Bench Model	Floor Model
Depth of throat	7¾ inches	7¾ inches
Spindle	No. 33 Jacobs taper	5-in. 4 step
Bearings	4 sets precision ball	4 sets precision ball
Chuck capacity	0 to ½-inch	0 to ½-inch
Spindle travel	4 inches	4 inches
Quill diameter	1⅝ inches	1⅝ inches
Depth graduations	¼ inch	⅜ inch
Work surface	10x10 in.	10x10 in.
Table travel	13⅞ in.	38¼ in.
Distance, base to chuck, maximum	18 inches	44½ inches
Machine pulley (incl.)	5-in. 4 step	5-in. 4 step
Motor pulley (incl.)	5-in. 4 step; ⅞-in. bore (keyed)	5-in. 4 step; ⅞-in. bore (keyed)
V-belt (included)	½x45 inches	½x45 inches
Motor recommended, minimum	½ HP 1725 RPM	½ HP 1725 RPM
9 speeds from	610 to 5000 RPM	610 to 5000 RPM
Mounting dimensions	9½x14⅞ in.	16⅞x14⅞ in.
Height	36 inches	65¼ inches
Width	12⅞ inches	18⅞ inches
Depth	19 inches	24 inches

Extra heavy-duty to meet the most rigid demands of professional craftsmen.

Check these outstanding features: (1) Pre-loaded bearings to take up wear . . . reduce spindle end play and drill breakage. (2) One-piece pulley and sleeve bearings for greater accuracy and economy. (3) Rubber bumper between quill and head absorbs shock of quill return. (4) "Floating Drive" spindle assembly . . . spindle floats freely within pulley.

Drills to center of 15½-inch circle. Four sets of heavy-duty, shielded, precision ball bearings; three-lever feed handle; "Safe-Lock" key chuck. Safer . . . swiveling threaded lock collar screws on spindle. Positive-acting quill lock permits you to do routing, shaping and mortising using proper attachments. Table rigidly held in perfect alignment at horizontal position . . . slotted to hold fixtures.

Perfect accuracy all the time . . . you'll be able to do work that's accurate to a thousandths of an inch.

Drill press has nine speeds, 610 to 5000 RPM with two matched 5-inch, four-step cone pulleys, ½-inch V-belt.

Floor Model Drill Press without motor. 65¼ inches high. Base to chuck 44½ inches. Maximum table travel 38¼ inches.

99 M 2453N—Shipping weight 172 pounds. Only \$5.00 down, \$6.00 monthly Cash \$119.50

99 M 24535N2—As above, but with CRAFTSMAN ½-HP 1725-RPM ball-bearing capacitor motor for 115-230-volt, 60-cycle AC. Shipping weight 203 pounds. Only \$5.00 down, \$7.50 monthly Cash \$149.50

Bench Model Drill Press without motor. 36 inches high. Base to chuck 18 inches. Maximum table travel 13⅞ inches.

99 M 2452N—Shipping weight 135 pounds. Only \$5.00 down, \$5.00 monthly Cash \$104.50

99 M 24525N2—As above, but with CRAFTSMAN ½-HP 1725-RPM ball-bearing capacitor motor for 115-230-volt, 60-cycle AC. Shipping weight 166 pounds. Only \$5.00 down, \$7.00 monthly Cash \$134.50

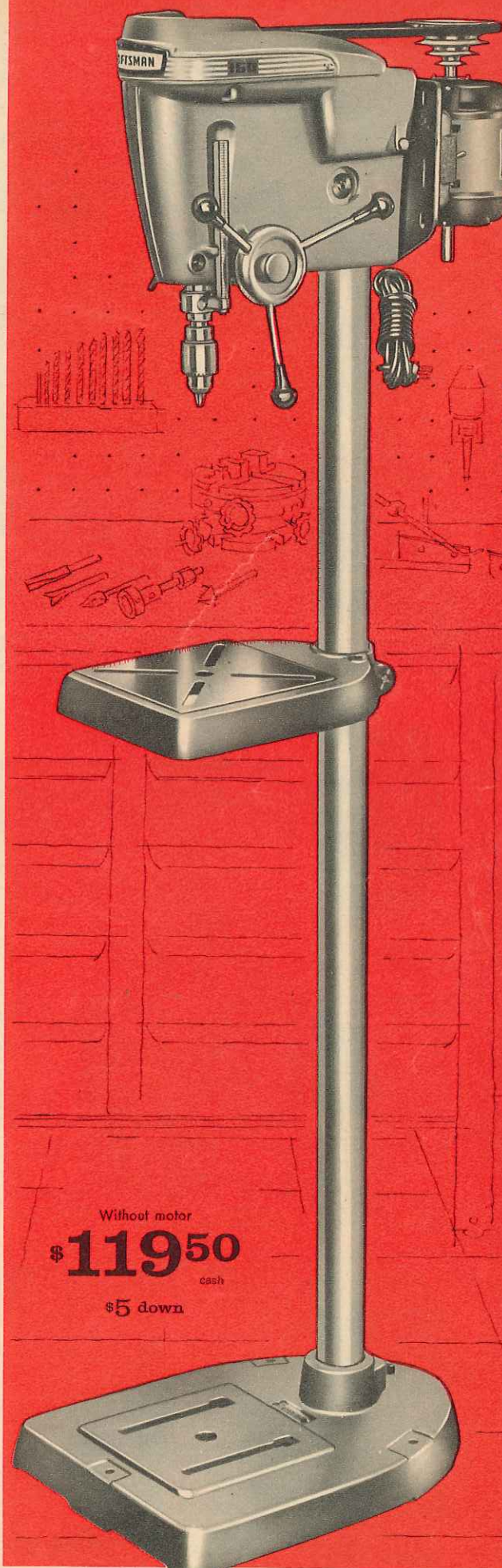

Without motor
\$119.50 cash
\$5 down

SPECIAL EASY TERMS . . ONLY \$5 DOWN . . see inside back cover

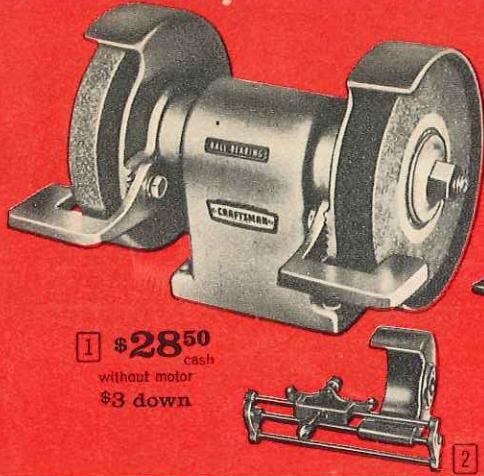

1 \$28⁵⁰ cash
without motor
\$3 down

CRAFTSMAN
REG. U.S. PAT. OFF.
**Belt-driven
Grinders**



3 \$16⁹⁸ without motor

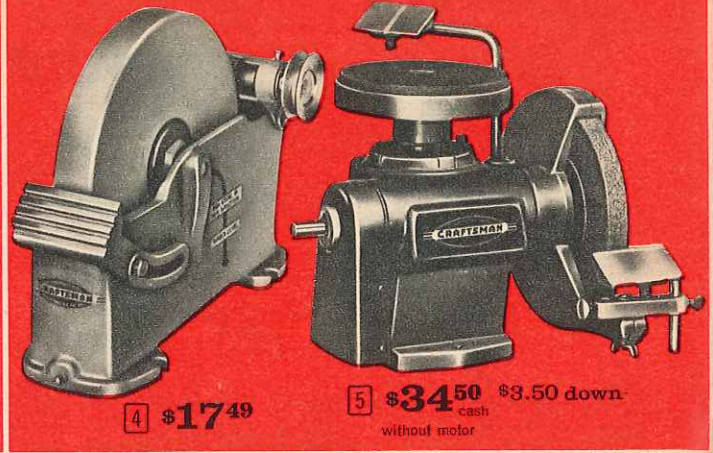

4 \$17⁴⁹

5 \$34⁵⁰ cash \$3.50 down
without motor

Wheels project about 1 1/2 in. for grinding large pieces

1 Heavy-duty 8-inch Grinder. Heavier cast iron body, shaft and wheels than grinder at right. For general farm, small shop or industrial use. Spindle runs on ball bearings. Each wheel enclosed 65% by protective guards. Adjustable tool rest. 1 1/4 x 1-inch spindle reduced to 3/4-inch x 10 thread at ends.

With 3-inch diameter single V-groove pulley; 1/2 x 40-inch V-belt; and two 8-inch grinding wheels with 1 1/4-inch faces (1 medium coarse and 1 medium fine). Power-bronze finish. Use minimum of 1/2-HP 1725 RPM motor with 5-inch motor pulley (not included).
99 M 6611K—Shipping weight 35 lbs. \$28.50

2 Sickle Attachment for grinder above. Holds mower knives rigid while sharpening. See *Sears Big Catalog* for sickle wheels.
99 M 6617C—Shipping weight 20 lbs. \$8.59

3 Low-priced 6-inch Grinder. All cast iron construction. Precision ball bearings are lubricated for life. Wheels extend in front of housing . . . you can easily grind large pieces across face. 1 3/4 x 3/8-inch spindle reduced to 1/2-inch x 20 thread at ends. Removable wheel guards; adjustable tool rests. Ideal for small shops.

With 2-inch machine pulley; two vitrified grinding wheels, 6 x 3/4-inch (1 coarse grit and 1 medium grit). Power-bronze finish.
99 M 6604K—Shpg. wt. 22 lbs. \$16.98

CRAFTSMAN 1/3-HP 1725-RPM Motor for grinder 99M6604K above. Use 110-120 volt, 60-cycle AC.
99 M 19669C—Shpg. wt. 16 lbs. \$16.98

Wet Grindstone

4 CRAFTSMAN. Neoprene-rubber drive roller squeezes off excess water . . . leaves right amount; ends splash.

Highest quality natural Ohio grindstone; 10-in. diameter; 1 1/2-in. face. Cast iron body and bearings. Adjustable 3-inch tool rest. Power-bronze finish. Drain plug. With 2 1/2-inch drive pulley. Use 2-inch pulley on 1725 RPM motor (not included).
99M6622K—Wt. 31 lbs. \$17.49

9 M 6621—Replacement Stone for above. Wt. 13 lbs. . . . \$3.98

CRAFTSMAN Grinder-Hone

5 GRIND, whet or hone with one machine. 3/4 x 6-inch grinding wheel turns at 3450 RPM . . . has 60-80 grit for quick removal of stock. 3/4 x 5-inch sandwich-type oilstone turns at 110 RPM for sharpening . . . has 120 grit for whetting and 320 grit for honing. DO NOT run spindle over 3450 RPM.

Adjustable tool rests; ball bearings. Gears and spindle run in bath of oil. All-steel construction . . . can take rugged use. Dimensions: 8 x 10 1/2 x 9 inches deep.
99 M 2267K—Shipping weight 21 pounds. . . \$34.50

Grinder-Hone above with CRAFTSMAN Motor. 1/2-HP 1725 RPM. For use with 110-120-volt, 60-cycle AC. With 38-inch V-belt and 4-inch motor pulley. Buy it now on *Sears Easy Terms* . . . only \$5 down.
99 M 22675K2—Shpg. wt. 46 lbs. . . . cash \$53.00

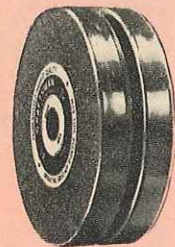

CRAFTSMAN Grinding Wheels

Perfectly balanced. High-quality, long-wearing aluminum oxide abrasive . . . cuts cool, fast and free. Meets highest industrial standards . . . your assurance of top performance.

Precision-ground on BOTH sides and face. Fully vitrified (crystallized) in an electrically controlled kiln for over 200 hours. Bushed to 1-inch center hole. Bushing furnished if you specify shaft diameter smaller than 1 inch. Grinding wheels with diameter up to 8 inches and 1/2, 3/4 and 1 inch thick have plastic bands to protect edges in shipment. Please order from table at bottom.

55c 3x1/2 inch

IMPORTANT SAFETY RULES: (1) Do not grind on side of wheels. (2) Grinding wheels should be used only on tools with concave flanges as large as, or larger than, shown in table below. (3) Use guard and shatterproof glass shield covering 3/4 of wheel. (4) For all wheels never exceed RPM shown. (5) Wear safety goggles. (6) Stand aside for one minute after starting wheel. (7) Follow safety instructions shown on all grinding and cut-off wheels. DO NOT USE ON WOOD.

Diameter, wheel, inches.	3.	4.	5.	6.	7.	8
Diameter, flange, inches.	1 3/4	1 3/4	1 3/4	2.	2 1/2	3
RPM.	8276	6207	4966	4138	3547	3103

HOW TO ORDER: Please state (1) catalog number; (2) diameter of wheel; (3) thickness of wheel; (4) center hole; (5) diameter of shaft.

SELECT THE CORRECT GRIT FOR THE JOB:

FINE for knives, keen-edged tools, finish grinding and polishing.
MEDIUM FINE for axes, woodcutting tools, preparation for finish.
MEDIUM COARSE for machine shop use, or fast removal of stock.

Diameter and thickness	Center hole	Minimum Size Shaft to use	Shipping weight	9 M 6415 Medium coarse 36 grit	9 M 6411 Medium fine 60 grit	9 M 6412 Fine 100 grit
3x 1/2 in.1 inch3/8 in.1 lb.	55c	55c	55c
3x 3/4 in.1 inch3/8 in.1 lb.	59c	59c	59c
4x 1/2 in.1 inch3/8 in.1 lb.	89c	89c	89c
4x 3/4 in.1 inch3/8 in.2 lbs.	\$1.09	\$1.09	\$1.09
4x 1 in.1 inch3/8 in.2 lbs.	1.19	1.19	1.19
5x 1/2 in.1 inch3/8 in.2 lbs.	1.39	1.39	1.39
5x 3/4 in.1 inch3/8 in.3 lbs.	1.49	1.49	1.49
5x 1 in.1 inch3/8 in.3 lbs.	1.69	1.69	1.69
6x 1/2 in.1 inch3/8 in.3 lbs.	\$1.49	1.49	1.49
6x 3/4 in.1 inch3/8 in.3 lbs.	1.69	1.69	1.69
6x 1 in.1 inch3/8 in.4 lbs.	1.89	1.89	1.89
7x 1/2 in.1 inch3/8 in.3 lbs.	1.79	1.79	1.79
7x 3/4 in.1 inch3/8 in.4 lbs.	2.19	2.19	2.19
7x 1 in.1 inch3/8 in.5 lbs.	2.49	2.49	2.49
7x 1 1/4 in.1 inch3/8 in.6 lbs.	2.79	2.79	2.79
8x 3/4 in.1 inch3/8 in.5 lbs.	2.49	2.49	2.59
8x 1 in.1 inch3/8 in.6 lbs.	2.89	2.89	2.89
8x 1 1/4 in.1 inch3/8 in.7 lbs.	3.39	3.39	3.39
8x 1 1/2 in.1 inch3/8 in.9 lbs.	3.89	3.89	3.98



DUNLAP Grinding Wheel Dresser

High carbon steel cutters. 12 inches long.
9 M 6492—Shipping weight 2 lbs. 2 oz. \$1.39
9 M 6495—Set of 4 extra cutters. Wt. 2 oz. 19c

32 SEARS Zone 1

Abrasive Wheels

Use goggles below for safety

Cut-off wheels below and at right are NOT for bench saws. NOT for cutting wood.

6 RESINOID-BONDED REINFORCED CUT-OFF WHEELS. Resist wobble . . . less danger of breaking. 3/32 inch thick. Maximum RPM, 6000. Be sure tool is guarded. Choice of three types.

Shop Wheel for cutting steel . . . 8-inch diameter. Aluminum oxide. Cuts steel bars, sheets, tubing, etc. Center hole bushed to fit both 3/8-inch and 1/2-inch round arbors.

9 M 6465—Shipping weight 10 oz. . . . \$2.98

Porcelain and Tile Cutter . . . 8-inch diameter. Silicon carbide. Also cuts marble, soapstone, plastics, copper, glass, cork, etc. Center hole bushed to fit 3/8-inch and 1/2-inch round arbors.

9 M 6466—Shipping weight 10 oz. . . . \$2.98

Brick and Concrete Cutters. Silicon carbide. Also cuts cast iron, brass, bronze, plaster, limestone, Transite, Masonite Presdwood, plastics, etc. Excellent for tuck pointing. See features above.

9 M 6467—Diameter, 8 inches. Center hole bushed to fit 3/8-in. and 1/2-in. round arbors. Shipping weight 10 ounces. . . . \$2.98

9 M 6468—Diameter, 6 in. Two center hole sizes: one fits 1/2-in. square or round; other fits 3/8-in. round. State 1/2 or 3/8-in. center hole size. Shipping wt. 9 oz. . . . \$1.98

9 M 6469—Diameter, 7 in. Fits Mall, Skil. Center hole bushed to fit 1/2 and 3/8-in. round arbors. Multi-purpose . . . fits arbors 1 1/16 in. square or diamond and 1 in. round. State 3/8-inch or multi-purpose center hole size. Shipping weight 10 oz. \$2.79



7 Rubber-bonded Cut-off Wheel. Aluminum oxide. Cuts metal bars, tubing, glass, plastics, etc. Max. RPM, 6000. Use coolant. 3/32 in. thick. Center hole bushed to fit 3/8 and 1/2-in. round arbors.
9 M 6470—Diameter, 8 in. Shpg. wt. 1 lb. \$1.49

8 CRAFTSMAN Rubber and Abrasive Polishing Wheel. Polishes and finishes all metals, plastics. For rust removal, die working, deburring, sharpening, etc. Easy to shape. 1/2-inch center hole. Max. speed recommended, 3800 RPM. State grit fine or medium.
9 M 2928—Diameter, 4 in., 1/2 in. thick. Wt. 9 oz. . . . \$1.49

9 "Craft-Rex" Cutting and Polishing Wheel. 1-in. center hole bushed for 1/2, 3/8, 3/4 in. (furnished). Use 24 grit to grind or cut steel, iron, copper, aluminum, etc. 80 grit is best for thin-walled metals . . . gives better finish on metals above. 120 grit does all the 80 grit will do, but gives a better finish.
9 M 6428—State diameter, grit and center hole size.

Diam.	Thickness	RPM	Grit	Shpg. wt.	Each
6 inch	1/16 inch	7500	120 (fine)	6 oz.	\$1.69
6 inch	3/32 inch	7500	80 (medium)	8 oz.	1.98
6 inch	1/8 inch	7500	24 (coarse)	10 oz.	2.29
7 inch	1/16 inch	6500	120 (fine)	8 oz.	2.19
7 inch	3/32 inch	6500	80 (medium)	10 oz.	2.49
7 inch	1/8 inch	6500	24 (coarse)	13 oz.	2.98
8 inch	1/16 inch	5700	120 (fine)	10 oz.	2.49
8 inch	3/32 inch	5700	80 (medium)	11 oz.	3.29
8 inch	1/8 inch	5700	24 (coarse)	15 oz.	3.98



10 For industrial chipping, grinding. 50-mm. lenses. Fully adjustable for comfortable fit.

9 M 1860—Shipping weight 9 ounces. \$2.59

9 M 1861—Fit over regular glasses. Wt. 12 oz. . . . 2.79

11 For machinists. Wire mesh shields. Meet U.S. Bureau of Standards requirements for impact. 6-base, 50-mm. precision-ground lenses.
9 M 1858—Lenses are hardened. Wt. 8 oz. \$2.59

12 Flexible Mask Goggles. Pliable plastic fits closely . . . gives maximum protection.
9 M 1859—Shipping weight 3 ounces. \$1.98

13 Goggles for wide-vision area. Clear safety lenses wrap around sides . . . protect while allowing greater viewing area. Aluminum frame with cushion.
9 M 1896—Shipping weight 4 ounces. . . . \$1.89

14 Face Shield. Rugged, clear plastic window gives protection to entire face. With sweatband for comfort.
9 M 1897—Shipping wt. 1 lb. \$2.98

Extra Window for above shield.
9 M 1898—Shipping weight 8 ounces. . . . \$2.98

CRAFTSMAN Enclosed-Motor Electric Grinders



1
\$36⁹⁵
 cash
 without pedestal
\$4 down

GUARANTEE

Grinders on this page will be repaired **FREE** if defects in materials or workmanship are found within **ONE YEAR** of purchase.



2
\$73⁹⁵
 cash
 without pedestal
\$5 down

Industrial-type, flat-face design . . . you can easily grind large pieces across the front

- All have enclosed motors with ball-bearings and heat-resisting Nylon insulation
- *UL listed.* For 110-120-volt, 60 cycle AC
- 1 fine, 1 coarse aluminum oxide wheels

1 1/4 HP . . . our best seller. 3450 RPM split-phase motor runs 6x3/4-in. grinding wheels. 2x1 1/8-in. adjustable tool rests; adjustable safety eye-shields. Oversized 3/4-in. motor shaft reduced to 1/2-in. x 20 threads at wheel ends . . . takes all standard accessories. Add wire wheel, 1/2-in. drill chuck, etc. Wheel guards are removable.

Base, 8 1/2 inches wide x 7 7/8 inches deep, mounts on pedestal at far right or on work bench. Toggle switch in base. Overall height 9 inches; width 14 3/4 inches. With 8-foot 2-wire cord and plug. Strongly constructed. Shipping weight 44 pounds.

99 M 1950L \$36.95

1/2 HP . . . for heavier work. (Not shown.) Similar to 1/4-HP model at left but larger. 3450 RPM capacitor motor drives 7x3/4-inch grinding wheels. 3/4-inch motor shaft has 1/2-inch x 20 threads at wheel ends . . . add standard accessories for versatility.

3x2 1/4-inch adjustable tool rests; large adjustable safety eye-shields. Removable wheel guards cover outside of wheel for maximum protection . . . have dust chute at rear. *UL listed (Industrial Standards).*

Overall height 10 inches; width 17 1/2 inches. Base 9 inches wide x 7 5/8 inches deep. Mounts on pedestal at right or on work bench. Toggle switch in base. 8-foot, 3-wire cord, adapter. Shpg. wt. 58 lbs.

99 M 1951L \$52.95

2 1/2 HP . . . heavy-duty industrial model. 3450 RPM capacitor motor drives big 7x1-inch grinding wheels. Features built-in goose-neck lamp and built-in water reservoir for cooling work. Adjustable tool rests on steel bar; large adjustable safety eye-shields. 3/4-inch motor shaft reduced to 5/8 in. x 18 threads at wheel ends . . . add accessories for versatility.

Solid, heavy construction. Height is 12 in.; width 19 3/4 in. Base 9 1/2 x 11 inches. Fits pedestal below or mount on work bench. Toggle switch in base; 8-ft., 3-wire cord and adapter. *UL listed (Industrial Standards).*

99 M 1952N—Shpg. wt. 85 lbs. \$73.95

3 CRAFTSMAN Grinder Pedestal. For any grinder on this page. 34 in. high; 2 1/4-in. steel column. 12x12 1/4 x 4 5/8-in. base bolts to floor. Bracket has grinder mounting holes.

99 M 2964K—Shpg. wt. 32 lbs. \$16.95

Safest Grinding Wheel ever developed

Three slip-on aluminum oxide abrasive bands (fine, medium, coarse) make one wheel do the work of three **\$5⁹⁸** 6x1 in. size

- Safe** . . . hard rubber is firmly anchored to dynamically balanced steel core.
- Versatile** . . . grinds almost anything: wood, plastic, aluminum, steel, rubber.
- Sure** . . . centrifugal force expands rubber wheel . . . holds bands tightly in place.
- Fast** . . . cushioning effect of rubber gives uniform pressure at contact point . . . greater grinding surface removes stock better, faster than ordinary wheels.
- Cool** . . . holes dissipate heat . . . expel hot air . . . give long life to rubber.
- Adaptable** . . . 3/4-inch center bushed for 5/8 and 1/2-inch diameter shafts.

9 M 64041—6x1-in. size. For 3450 RPM motors or grinders. Shpg. wt. 2 lbs. 4 oz. \$5.98
 9 M 64042—6x1 1/2-in. size. For 3450 RPM motors only. Shpg. wt. 2 lbs. 14 oz. 7.98

Replacement Abrasive Bands for above . . . aluminum oxide with cloth back.
 9 M 22851—Three 6x1-in. Bands. State fine, medium or coarse. Shpg. wt. 5 oz. \$1.19
 9 M 22852—Three 6x1-in. Bands. 1 each of fine, medium, coarse. Shpg. wt. 5 oz. 1.19
 9 M 22853—Three 6x1 1/2-in. Bands. State fine, medium, coarse. Shpg. wt. 6 oz. 1.39
 9 M 22854—Three 6x1 1/2-in. Bands. 1 each of fine, medium, coarse. Shpg. wt. 6 oz. 1.39

Karbo-Grit Bands for wheels above. Diamond-hard tungsten carbide grits brazed on steel bands. State choice of fine, medium or coarse.
 9 M 3020—6x1-in. size. Wt. 7 oz. \$1.79 9 M 3021—6x1 1/2-in. size. Wt. 7 oz. \$1.98

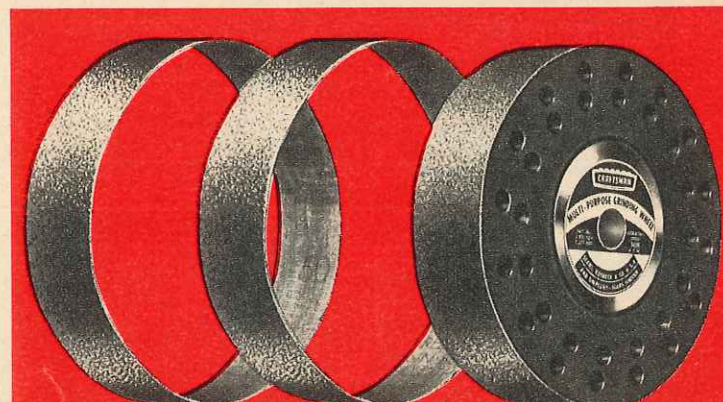

FINE

MEDIUM

COARSE

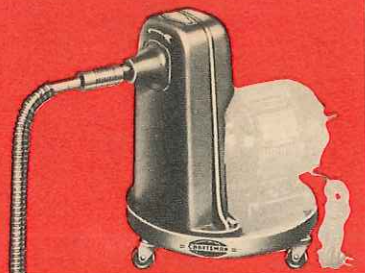

CRAFTSMAN Portable Shaft Outfit

Portable Base only. Three ball-bearing swivel casters. Base tilts about 30° on its rim. Has holes for mounting 9M2621 Multispeed Device (below). With bolts. Power bronze finish.

9 M 2620—Shipping wt. 6 lbs. \$5.79

Multispeed Device only. For base 9M2620 above when using 50 or 72-inch Flexible Shaft, and ¼, ½ or ¾-HP 1725 RPM motor. Gives 3 speeds; about 875, 1725 and 3450 RPM. ¾-inch ball-bearing shaft; smooth, quiet running. Two cone-type pulleys; floating motor mount; V-belt; bolts. Power bronze finish. Height 12½ inches.

9 M 2621—Shipping weight 9 lbs. . . \$22.50

CRAFTSMAN 50-inch Flexible Shaft. Fits ½ or ¾-inch motor shaft. Aluminum alloy handpiece and motor coupling. Precision ball bearings. Black rust-resistant steel end fittings. ¾-inch core. Spindle is ½-inch by 20 thread.

9 M 2633—Flexible Shaft only.

Shipping weight 6 pounds. \$13.98

9 M 2634—Shaft Extension, 38 inches long.

Makes shaft above 88 inches long.

Shipping weight 3 lbs. 2 oz. \$5.39

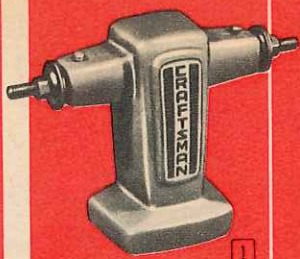

1



3

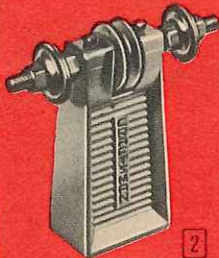

2

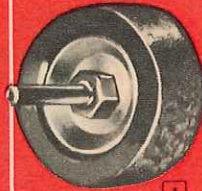

4

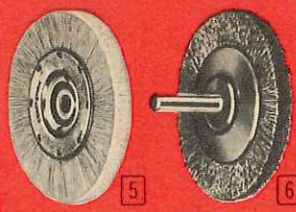

5



6



7



8



10

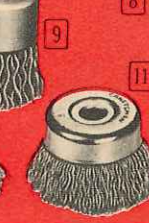

11



12

13



15

16

Polishing Heads

Designed for effective polishing, paint and rust removal, drilling, etc. Both models have heavy cast iron frames, attractive power bronze finish. Use with standard accessories. Complete with V-type pulley for ¾ or ½-inch V-belt.

Not recommended for use with grinding wheels.

1 CRAFTSMAN general-purpose Polishing Head. Real professional quality. Solid frame for minimum of vibration . . . allows you to do a better, more precise job.

Overall height 7¾ inches. Spindle is ¾ by 11¾ inches . . . ½ inch by 20-thread at ends.

Drive from rear or below. Porous bronze bearings with oil well around each. Spring cap oil cups seal out dust for longer life. 1¾-inch stamped steel flanges. With pulley for ¾ or ½-inch V-belt.

9 M 6603—Head only. Without motor, motor pulley or V-belt. Shipping weight 8 lbs. 8 oz. \$6.49

9 M 6603K2—Head with CRAFTSMAN ½-HP 1725 RPM sleeve-bearing split-phase motor (110-120-volt, 60-cycle AC). 4-inch motor pulley and 34-inch V-belt included. Shipping weight 34 pounds. \$23.49

2 Low-priced Polishing Head. Dependable quality. Ideal for small shops.

Overall height 7½ inches. Spindle is ½ by 7 inches . . . ½ inch by 20-thread at ends.

Can be driven from three directions . . . mount motor to rear, below or above polishing head.

Cast iron bearings. Neoprene oil-hole plugs. 1¾-inch stamped steel flanges. With pulley for ¾ or ½-inch V-belt. Motor, motor pulley and V-belt not included. Proper motor (1/3 HP, 1725 RPM, split-phase) may be ordered separately on page 64.

9 M 6602—Shpg. wt. 4 lbs. 4 oz. . . \$3.29

Scour, clean, buff, sand and polish with these aids

3 Sanding Drum. Three-inch face; 2¾-inch diameter. Screws on ½-inch by 20-thread shaft. Medium grit sleeve over expanding rubber drum.

9 M 25245—Shipping weight 14 oz. . . . \$1.98

Sanding Sleeve. For use with sanding drum above. Choice of fine, medium or coarse grit. *State grit wanted.*

9 M 2522—Shipping weight 2 oz. 19c

4 Sanding Drums. 1-inch face; ¾-inch plain spindle; 1½ inches long. Use with collet chuck. With one abrasive sleeve held by expanding rubber drum.

9 M 2497—½-in. diam. Shpg. wt. 5 oz. \$1.09

9 M 2498—2¾-in. diam. Shpg. wt. 6 oz. . 1.19

9 M 2499—3-in. diam. Shpg. wt. 9 oz. . . 1.39

Sanding Sleeves. For drums above. Choice of fine, medium or coarse grit. *State drum diameter and grit wanted.*

9 M 2442—Shpg. wt. 3 oz. Pkg. of six 49c

5 Tampico Fiber Wheel Brush. Tampico fiber; metal center. Six-inch diam., ¾-inch face, ½-inch center hole.

9 M 6486—Shipping weight 11 oz. . . . \$1.29

6 Wire Wheel Brushes. ¼-inch spindle; 2½ or 3-inch diameters. *State fine or coarse.*

9 M 6489—2½-in. diameter.

Fine. Shpg. wt. 4 oz. \$1.49

Coarse. Shpg. wt. 4 oz. 1.29

9 M 6490—3-in. diameter.

Fine. Shpg. wt. 4 oz. 1.49

Coarse. Shpg. wt. 4 oz. 1.29

7 Wire Scratch Wheels. Use to remove rust, paint, etc. Contractors use them to finish concrete walls. *State catalog no., diam. and center hole size.*

9 M 6480—Coarse

Diam.	Width	Hole	Shpg. wt.	Price
4 in.	7/16 in.	½ in.	5 oz.	.79c
6 in.	9/16 in.	½ or ¾ in.	11 oz.	\$1.29
8 in.	1½ in.	½ or ¾ in.	1 lb.	1.59

9 M 6482—Fine

Diam.	Width	Hole	Shpg. wt.	Price
4 in.	¾ in.	½ in.	5 oz.	\$1.19
6 in.	1½ in.	½ or ¾ in.	11 oz.	1.69
8 in.	2 in.	½ in.	1 lb.	2.19

9 M 6483—Heavy Duty

Diam.	Width	Hole	Shpg. wt.	Price
4 in.	1 in.	½ in.	14 oz.	\$2.69
6 in.	1½ in.	½ or ¾ in.	1 lb. 12 oz.	3.29
8 in.	2 in.	½ in.	2 lbs. 6 oz.	3.98

8 Floor Brush. For scrubbing, waxing floors, etc. 6-inch diameter; ½-inch center hole. With Tampico fibers 1 inch long.

9 M 6487—Shipping wt. 1 lb. 2 oz. . . . \$1.89

9 Carbon Removing Brush. 1-inch diameter. ¼-inch plain shank.

9 M 6484—Shipping weight 6 oz. 98c

10 Wire Cup Brush. For cleaning or polishing. 1¾-in. diameter; ¼-in. shank. *Please state choice of fine or coarse wire.* Shipping weight 4 oz.

9 M 6488—Fine \$1.49 Coarse. . . . \$1.29

11 Wire Cup Brushes. Coarse wire. Remove rust, etc. 2¾-inch diam.

9 M 6485—½-in. center hole. Wt. 6 oz. \$1.39

9 M 6496—¼-in. shank. Wt. 8 oz. . . . 1.59

12 Lamb's Wool Polishing Drum. Fits over sanding drum 3 in. long by 2½-inch diameter. 1-inch wool pile.

9 M 2533—Shipping weight 3 oz. 98c

13 CRAFTSMAN Lamb's Wool Polishing Bonnets. Fit over sanding discs.

Cat. No.	Fit discs	Pile	Wt.	Price
9 M 2520.	3½ to 4 in.	1 in.	2 oz.	.59c
9 M 2521.	4 to 5½ in.	1 in.	6 oz.	.79c
9 M 2527.	.6 inches.	1 in.	8 oz.	\$1.19
9 M 2528.	.7 inches.	1¼ in.	8 oz.	1.39
9 M 2539.	.8 inches.	1¼ in.	8 oz.	1.79

9 M 6493—Spiral-sewed Double Thickness

Bufs. Bleached muslin with minimum 64x64-

thread count. *State catalog number and diam.*

Diam.	Hole	Layers	Shpg. wt.	Price
4 in.	½ in.	...30...	3 oz.	.49c
6 in.	½ in.	...30...	6 oz.	.75c
8 in.	½ in.	...30...	11 oz.	\$1.19

9 M 6494—Loose Concentric-Sewed Bufs.

Some quality as above buf. *Please state diam-*

eter wanted.

Diam.	Hole	Layers	Shpg. wt.	Price
4 in.	½ in.	...30...	2 oz.	.49c
6 in.	½ in.	...30...	4 oz.	.75c
8 in.	½ in.	...30...	7 oz.	\$1.19

14 CRAFTSMAN Buffing Wheels.

Highest quality high thread-count

discs. They last longer, stand up bet-

ter under high speeds. Raked edges.

Choice of two types.

9 M 6493—Spiral-sewed Double Thickness

Bufs. Bleached muslin with minimum 64x64-

thread count. *State catalog number and diam.*

Diam.	Hole	Layers	Shpg. wt.	Price
4 in.	½ in.	...30...	3 oz.	.49c
6 in.	½ in.	...30...	6 oz.	.75c
8 in.	½ in.	...30...	11 oz.	\$1.19

9 M 6494—Loose Concentric-Sewed Bufs.

Some quality as above buf. *Please state diam-*

eter wanted.

Diam.	Hole	Layers	Shpg. wt.	Price
4 in.	½ in.	...30...	2 oz.	.49c
6 in.	½ in.	...30...	4 oz.	.75c
8 in.	½ in.	...30...	7 oz.	\$1.19

15 CRAFTSMAN Buffing Compound

. . . Set of 4 Bars. One 5-ounce bar

each of Emery (black), Tripoli

(brown), Red and White Rouge.

9 M 2896—Shipping weight 2 lbs. 89c

CRAFTSMAN Buffing Compound Bar.

5-ounce bar all-purpose buffing com-

pound for plastics or metals.

9 M 2865—Shipping weight 8 oz. 29c

White Rouge Buffing Compound. 5-

ounce bar for stainless steel, alumi-

num, nickel, etc.

9 M 2860—Shipping weight 8 oz. 29c

16 CRAFTSMAN Buffing Set. For ½-

inch shafts. Set includes one 6-inch

double-thick muslin buffing wheel,

one 5-ounce bar Red Rouge buffing

compound, one 5-ounce bar Tripoli

(brown) buffing compound.

9 M 2864—Shpg. wt. 1 lb. 1 oz. \$1.29

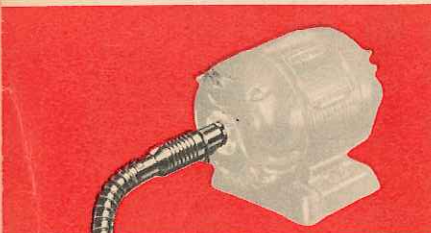

CRAFTSMAN 72-inch Flexible Shaft.

Extra heavy duty construction delivers power anywhere you want it. Extra long . . . get in more difficult places for high speed drilling and grinding. Strong casing has spiral steel liner, an oil-resistant fabric jacket, and a steel wire and braid reinforced heavy synthetic rubber cover. Will not scratch surfaces.

Chrome-plated steel handpiece and motor coupling both have extra large precision ball bearings for smoother operation and longer wear. Handpiece is knurled for firm grip. Spiral steel outer reinforcement at motor end protects casing at point of wear. Black steel end fittings. Fits ½-in. or ¾-in. motor shaft; has ½-inch steel wire core. Spindle ½ inch by 20 thread.

Consists of casing, core, motor coupling and handpiece.

99 M 2655L—Flexible Shaft without

motor. Shipping weight 12 lbs. \$38.95

9 M 2682—Replacement Core for

above. Shpg. weight 3 lbs. 4 oz. 8.98

9 M 2622—Replacement Core for 50-inch

flexible shaft above.

Shipping weight 1 lb. 2 oz. \$2.98



Angle Head

Lightweight, cast aluminum head. Ball and needle bearings. One-to-one gear ratio. Easy-to-hold rubber hand grip. Fits 99 M 2655L (listed above) flexible shaft only.

9 M 2628—Shpg. wt. 2 lbs. 8 oz. . . . \$33.95



Wheel Guards

With hand grip. Use with 4-in. grinding or wire-scratch wheels. Wt. each 1 lb. 3 oz.

9 M 2637—For flexible

shaft with 1½-in.

diam. handpiece. (9M2633 above). . . \$3.79

9 M 2638—For flexible shaft with 1¾-

in. diam. handpiece. (9M2655L above). . \$3.79



\$3850
cash
Without motor,
motor pulley
or V-belt
\$4 down



\$7450
cash
Without motor,
motor pulley
or V-belt
\$5 down

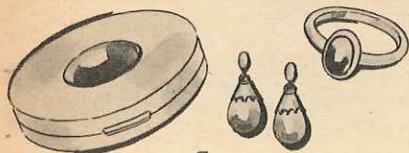

6-inch CRAFTSMAN Gem Maker

With "supercharged" diamond wheel; cast iron lap wheel; silicon carbide grinding wheel; silicon carbide scratch wheel; polishing wheel; 4 oz. each of No. 100 and No. 220 grinding compound; 3 oz. polishing compound; 3 brushes; 6 dop sticks; 1 stick dop cement; assorted stones for cutting; 1/2 pt. soluble oil; instructions. Overall height 11 1/4 in. All wheels 6-in.

99 M 1400C—6-inch Gem Maker. Shipping wt. 18 lbs. \$38.50
99 M 19669K—1/2-HP 1725 RPM motor for above. 110-120 v., 60-c. AC. Use 2-in. motor pulley, 32 to 48 in. V-belt. Shpg. wt. 16 lbs. \$16.98

Cut and polish gems . . . for fun and profit

Make perfect cuts faster . . . "supercharged" diamond wheels have more diamond chips which mean extra cutting surfaces for speed, accuracy. Strong aluminum alloy castings . . . legs bolt solidly to bench. Lubrication cup moves around rim. Deep lipped rim. Rifled-drilled shaft for forced lubrication to bearing. Designed to give you a profitable, relaxing hobby. Precision crafted to make even delicate work seem easy.

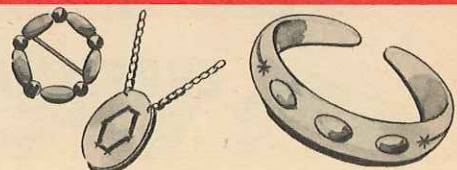

10-inch CRAFTSMAN Gem Maker

With 10-in. "supercharged" diamond wheel; 10-in. cast iron lap wheel; 3 special 8-in. wheels: silicon carbide grinding, silicon carbide scratch and felt polishing; 4 oz. No. 100 grit compound; 4 oz. No. 220 grit compound; 3 oz. polishing compound; 3 brushes; 6 dop sticks; dop cement; assorted stones; 16-oz. can soluble oil; weights for sawing.

99 M 1401L—10-inch Gem Maker. Instruct. Shpg. wt. 40 lbs. \$74.50
99 M 19669K—1/2-HP 1725 RPM motor for above. 110-120 v., 60-c. AC. Use 2-in. motor pulley, 23 to 48-in. V-belt. Shpg. wt. 16 lbs. \$16.98

Workshop proven CRAFTSMAN accessories and supplies for gem making

Grinding Compound. Silicon carbide. One pkg. each of No. 100 and No. 220 grit. 12-oz. packages.

9 M 1441—Wt. 2 lbs. 4 oz. Two pkgs. \$1.39

Dop Cement and Dop Sticks. 5-oz. pkg. of Dop Cement; 6 Dop Sticks.

9 M 1442—Shipping wt. 10 oz. \$1.19

Replacement Discs. For 9 M 1406 scratch wheels. Silicon carbide.

9 M 1405—State diameter wanted.

6-inch. Shpg. wt. 2 oz. Four for \$1.29

8-inch. Shpg. wt. 4 oz. Three for 1.29

Scratch Wheels. Silicon carbide. 220 grit for taking scratches out of gems.

9 M 1406—State diameter wanted.

6-inch. Shipping wt. 8 oz. Each 98c

8-inch. Shpg. wt. 1 lb. 4 oz. Each \$1.29

Silicon Carbide Grinding Wheels. 100 grit, 1/2-in. bore. 6x1/2 in. or 8x3/4 in.

9 M 1407—State diameter wanted.

6-inch. Shpg. wt. 1 lb. 4 oz. Each \$3.29

8-inch. Shpg. wt. 4 lbs. 10 oz. Each \$5.79

Soluble Oil for Sawing. Pint can.

9 M 1429—Shpg. wt. 1 lb. 12 oz. 69c

Felt-on-wood Polishing Wheels. 6 or 8-inch diameter. 1/2-inch bore.

9 M 1410—State diameter wanted.

6-inch. Shipping wt. 8 oz. Each \$1.69

8-inch. Shpg. wt. 1 lb. 4 oz. Each 2.19

Polishing Compound. 12-oz. package.

9 M 1403—Shpg. wt. 1 lb. 2 oz. \$1.59

One-pound Package of Assorted Semi-Precious Stones. Contains Agate and Obsidian stones up to 1 inch in diameter. Stones are ready to be cut and polished.

9 M 1443—Shipping wt. 1 lb. 7 oz. \$1.98

Diamond "Supercharged" Cutting Wheels. For Gem Makers above and many others. 1/2-inch bore. Use with 9M1429 soluble oil at left. 8 and 12-inch sizes shipped from factory near Chicago, Illinois. Please state diameter wanted.

Cat. No.	9 M 1418	F9 M 1418
Diam.	6 in.	10 in. 8 in. 12 in.
For.	99M1400C	99M1401L 99M1401L
Wt.	9 oz.	1 lb. 2 oz. 1 lb. 2 lbs.
Each.	\$13.98	\$22.50 \$16.98 \$29.50

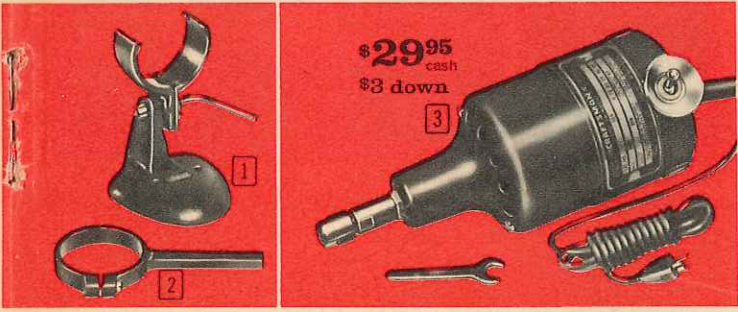

\$2995
cash
\$3 down

1 Bench Stand for grinder. Doubles its use! Positions grinder vertically upward, horizontally or 45° above or below horizontal. Tilts to either side. Leaves hands free to hold work piece. Two holes for mounting to bench.

9 M 25976—Shpg. wt. 3 lbs. 2 oz. \$4.98

2 Tool Post Holder for grinder. Converts grinder into a Tool Post Grinder for metal-working lathes. Slips into tool post, clamps grinder in place for accurate operation. Makes outer and inner diameter grinding easy.

9 M 25978—Shpg. wt. 1 lb. 6 oz. \$4.98

3 Rotary Grinder. You'll find dozens of ways to use this handy helper. Grinds and polishes wood, metal, plastics or glass. A perfect tool for dental laboratories. Sharpens chain saws 70% faster than hand filing! Lightweight . . . easy to hold. Use as a tool post grinder for metal lathes.

See tempered steel rotary cutters and grinding points listed on page 28 for use with this grinder.

Ball bearings for smooth, trouble-free operation. For 3/8, 1/2 and 3/4-inch shank tools. 1/14 horsepower, 17,000 revolutions per minute motor. 110-120-volt, 25-60-cycle AC-DC. Guaranteed one full year.

9 M 2597—Shipping wt. 4 lbs. 2 oz. \$29.95

CRAFTSMAN Mandrels . . . to build your saw, grinder, jack shaft, etc.

4 CRAFTSMAN Bronze-Bearing Saw Mandrels. Steel shaft extends 1 1/4 in. at threaded end; pulley end flattened for set screw. Washer diam. 1 3/4 in. 2 porous, permanently lubricated bronze bearings; 1/2-in. size (shaft 3/8 in.) has 2-in. diam. V-pulley. 1/2-in. size (shaft 1/2 in.) has 2 1/2-in. diam. V-pulley. For 1/2-in. V-belt. Right-hand thread.

Catalog Number	Size In.	Shaft length	Arbor End Threaded	Wt. lbs. oz.	Each
9 M 4940 . . .	1/2	9 13/32 in.	1/2 x 20 in.	2 8	\$.44.49
9 M 4941 . . .	3/8	11 1/16 in.	3/8 x 18 in.	3 5	\$.48.89



Low as **\$4.49**

5 CRAFTSMAN Ball-bearing Saw Mandrels. Compact, one-piece cast-iron housing eliminates twist and misalignment. Mounting brings shaft closer up under top of table giving greater depth of cut. 3/4-in. steel shaft with machined flanges (one fixed, one removable). Washer diam. 1 3/4 in. Pulley end of shaft extends 1 1/2 in., has flat area for pulley set screw. Right hand thread only.

Catalog Number	Shaft length	Arbor End Threaded	Extends	Wt. lbs. oz.	Each
9 M 4953 . . .	9 13/32 in.	1/2 x 20	1 1/2 in.	3 8	\$.63.39
9 M 4954 . . .	11 1/2 in.	3/8 x 18	1 1/2 in.	4 5	\$.73.99



Low as **\$6.39**

6 CRAFTSMAN Double-end Mandrel. Designed for more versatile operations. Use two attachments at the same time on right and left-hand threaded (1/2x20) spindle ends. With two porous, permanently lubricated bronze bearings. 3/8-in. diam. steel spindle (1/2-in. diam. at threaded ends) extends 1 1/4 in. beyond inside flange at each end. 2-in. diam. pulley (supplied) for 1/2-in. V-belt. Washers (2 at each end) are 1 3/4 in. in diam. Overall dimensions: height, 2 1/16 in.; width, 3 1/2 in., length 9 1/2 in.



Low as **\$4.89**

9 M 4942—Shipping weight 3 pounds. \$4.89

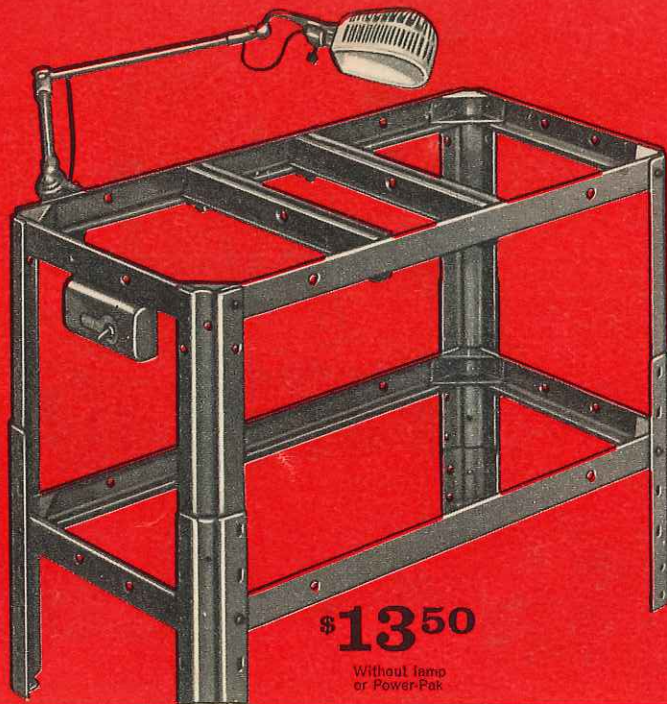

\$1350

Without lamp
or Power-Pak

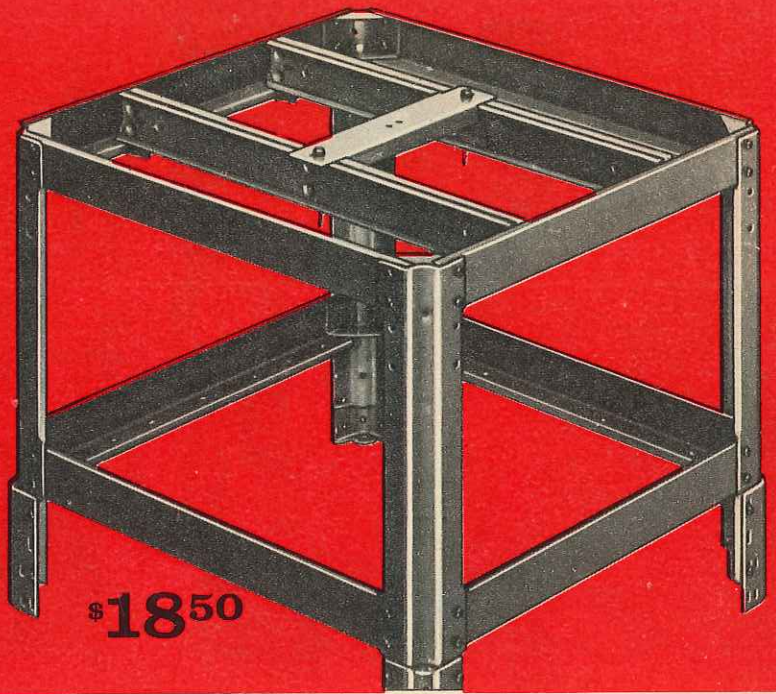

\$1850

CRAFTSMAN Adjustable Power Benches

REG. U. S. PAT. OFF.

Rock-solid bases set your tools at the correct height

NOTE: See chart below to determine which CRAFTSMAN Power Tools fit bench.

CRAFTSMAN Adjustable 16¼x30-inch Power Tool Bench. Designed to mount individual tools such as bench saws, jig saws, band saws, sanders, etc. Legs adjust to floor level. Height adjusts from 23¼ to 29¾ inches. Cross slide clamps are designed to hold the tools in a rigid position. Strong steel construction. Legs are

punched to take wheel set 9M2244 described below at the left. Bench includes two cross slides, hardware and instructions. Shipped unassembled.

99 M 10525K—Shipping wt. 28 lbs. \$13.50

9 M 2729—Extra Cross Slides. Welded steel. For power tool bench above. Shipping weight 1 pound 14 ounces. Each \$1.29

NOTE: See chart below to find which CRAFTSMAN Power Tools fit bench.

CRAFTSMAN 26x26-inch Power Tool Bench. Designed especially for bench saws. Heavy-duty construction provides excellent rigidity . . . that means less vibration which makes precision cuts easy. Adjust height to 22 or 25¼ inches. Legs pre-punched for installation of wheel set listed below at left. Bench includes 2 cross slides, hardware and instructions. Shipped unassembled.

99 M 10425L—Shipping weight 46 pounds. \$18.50

Bench-type Power Tool	Catalog No. of Power Tool	Extra V-belt (size)	Cross Slides Needed	Motor Mount 9M2730	Bench-type Power Tool	Catalog No. of Power Tool	Extra V-belt (size)	Cross Slides Needed	Motor Mount 9M2730
99 M 10525K works with the following power tools:									
Band Saws	99 M 2455N	45 in.	1	1	Drill Presses	99 M 2452N	incl.	none	none
	99 M 2425N	50 in.	1	1		99 M 2362N	incl.	1	none
Belt Sanders	99 M 2236C	37 in.	1	1	Hack Saw	99 M 2292L	44 in.	1	1
	99 M 2250L	42 in.	1	1	Jig Saw	99 M 2072N	54 in.	1	1
Bench Saws	99 M 2999N	incl.	none	none	Jointer-Planers	99 M 2067N	43 in.	1	1
	99 M 2000N	incl.	none	none		99 M 2186L	43 in.	1	1
	99 M 2104L	incl.	none	none	Thickness Planer	99 M 2061N	45 in.	1	1
						99 M 2370N	54 in.	1	1

Bench-type Power Tool	Catalog No. of Power Tool	Extra V-belt	Cross Slides needed	Motor Mount 9 M 2730
99 M 10425L works with the following power tools:				
Bench Saw	99 M 2999N	included	none	none
	99 M 2000N	included	none	none
	99 M 2104L	included	none	none
Swing Saw Shaper	99 M 2545N	included	none	none
	99 M 2392N	included	none	none

2 reasons why your shop should be equipped with Craftsman Power Tool Benches

1 You do better work because tools are provided with a solid base . . . tools are placed at the right working height
2 Greater safety . . . no danger of tools tipping

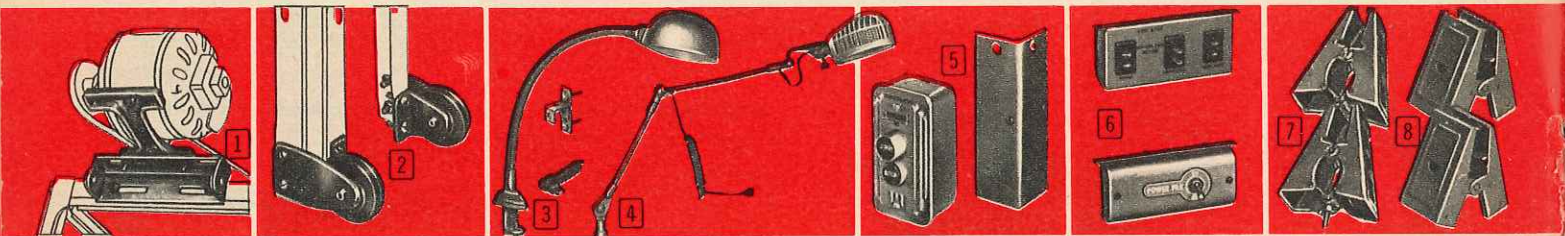

Motor Mount . . . Wheel Set

1 Swivel Motor Mount. Rocking motor motor bracket for use on 99 M 10525K CRAFTSMAN adjustable power tool bench listed above. To determine which power tools require mount see charts above. Fastens to motor base; helps maintain proper V-belt tension. Mounts on top rail of bench or on cross slide, beneath top rail. Steel, punched for bolts. Bolts not included.
9 M 2730—Shpg. wt. 1 lb. 9 oz. . . . \$1.19

2 CRAFTSMAN Wheel Set. Fits benches above. Feet punched, ready to attach. Makes moving bench and power tools easy. Heavy steel plate with hard rubber wheels. Works like a wheelbarrow. Shipping weight 2 lbs. 4 oz.
9 M 2244. Set of two \$1.69

36 SEARS Zone 1

CRAFTSMAN Workbench Lamps

3 Gooseneck type. Metal bracket fastens to all power tool benches, pedestal stands or mounts on flat work surface. For bench saws, jointer-planers, shapers, etc. 18-inch flexible gooseneck. Interlocking socket metal shade swivels 360°. With 6-foot cord. Power bronze finish. *UL listed.* Use 60-watt bulb (not included).
9 M 2536—Shpg. wt. 3 lbs. 8 oz. . . . \$4.49

4 Tubular type. For shop, inspection bench, machine tools, or laboratory. Tubular steel arms adjust on 2 ball-and-socket and 1 swivel joint. Base fits leg perforations for mounting on benches listed above, pedestal stands and flat surfaces.

Use 100-w. bulb (not incl.). Nylon shield prevents burning hands. Power bronze finish. 4½-ft. cord. 36 in. long overall. *UL approved.*
9 M 2504—Shpg. wt. 3 lbs. 12 oz. . . . \$5.98

Switch, Power-Pak for workshops, industrial use

5 Heavy-duty Switch. Designed to meet rugged requirements set for industrial use. Put it in your own workshop where heavy-duty switching is needed . . . takes day-in, day-out switching with practically no wear. Double pole switch breaks both sides of power line. Mounting bolts and bracket included for adapting to wood or metal benches.

May be used with Floor Model Saw 99 M 2245N listed and described on page 14; also use it with our former numbers 2727, 2444 and 2468.

Extra heavy duty 1½-HP rated switch . . . 125-230-volts, AC or DC. Easy to install and use.
9 M 2961—Shipping weight 2 pounds. Each \$7.50

6 CRAFTSMAN Power-Pak is the safer way to hook up power tools, motor and tool light. It's convenient—centers all power at one point . . . eliminates hazard of reaching over moving parts to turn motor on or off. On-off toggle switch located on front of receptacle box. Fits benches listed above and pedestal-type stands. Can also be used on other wood or metal tool benches. Heavy-duty 1-HP rated switch, 125-250 volts, AC or DC. Complete with one double prong receptacle that receives power . . . two plug-in taps to plug in motor and light.
9 M 21205—Shipping weight 1 pound 3 ounces. \$4.29

Brackets

7 Heavy-duty Saw Horse Brackets. No nails or bolts needed. Easy to set up and take down. Steel enamel finish. (Use with 2x4s—not included.) Shpg. wt. per pair 6 lbs.
9 M 2849—Pr. \$3.59

8 Saw Horse Brackets. Use with nails. Hinge action provides easy folding of saw horse. Enamelled steel. (Use with 2x4s—not incl.) Wt. per pair 2 lbs. 8 oz.
9 M 2887—Pr. \$1.79

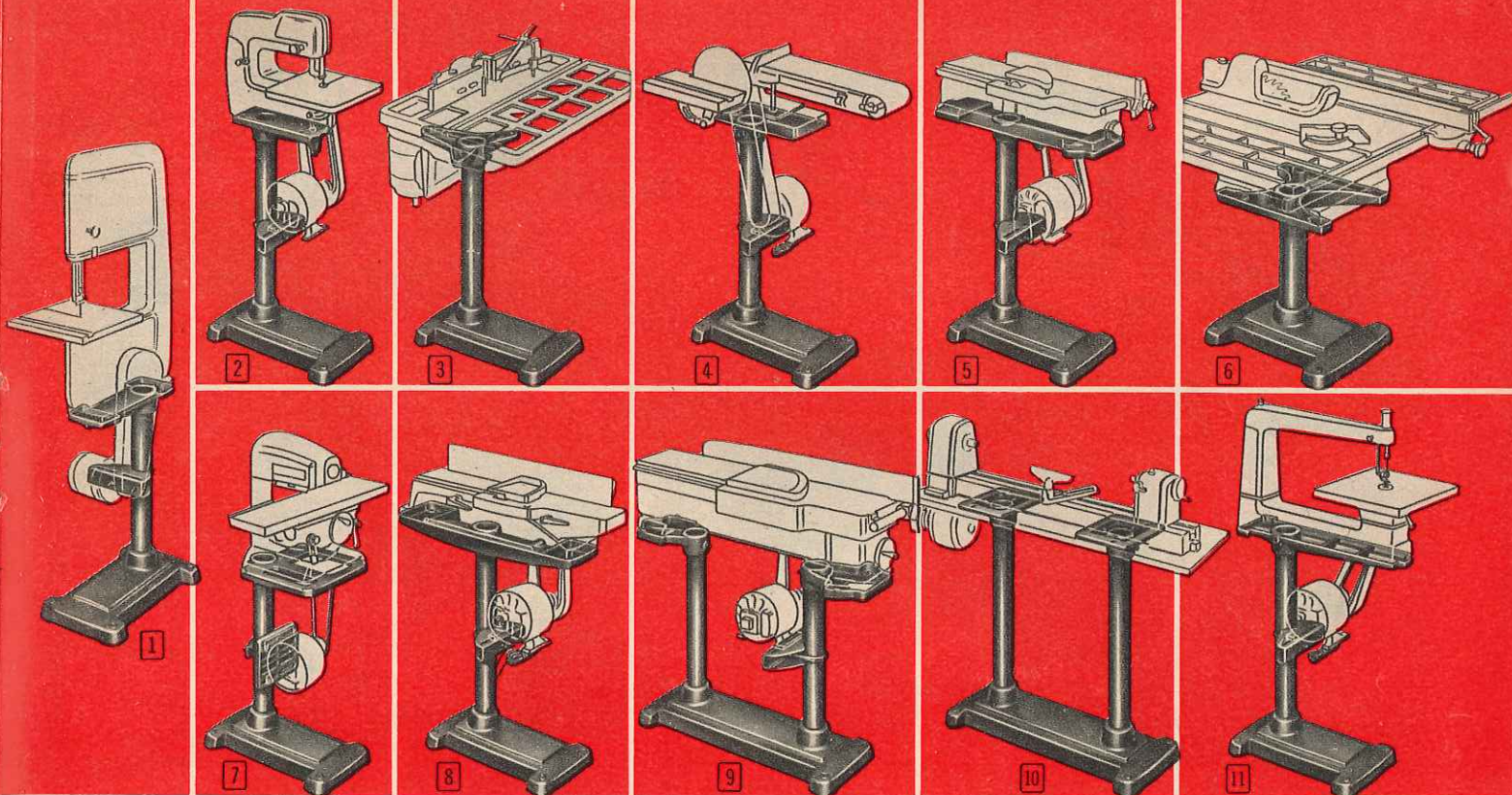

CRAFTSMAN Pedestal-type Tool Stands

REG. U. S. PAT. OFF.

Give power tools rigid base . . . ball casters make them easy to move

CRAFTSMAN Pedestal-type Tool Stands have features found in no other tool stand. You get mobility, rigidity and compactness . . . all at a low price.

Stands have easy-rolling ball-type casters which may be purchased as accessories (see below table at right). You can move any power tool in your shop from one place to another.

For extra rigidity . . . heavy cast iron base provides maximum support; high quality steel column and cast iron bracket support the tool absolutely level. Engineers designed these stands to provide you with more room in your workshop. The motor mount fits snugly under the power tool or to the rear . . . all in one unit. When not in use, pedestal-mounted power tools may be rolled together into one corner for compact storage.

There is a CRAFTSMAN Pedestal-type Power Tool Stand for every power tool in your workshop. (See chart at right). We believe this is the largest assortment offered today by anyone. Use them in machine shops, garages, factories, farms and in home workshops. Metal guard accessory available. Sturdy guard fits compactly and rigidly over V-belt leading from motor to power tool providing maximum safety for operator. *When ordering be sure to state catalog number, both for Tool Stand and for Tool Stand Guard.*

Buy Tool Stands on Easy Terms. See inside back cover for full details.
Stands F99 M 2958L and F99 M 2224L shipped from Ypsilanti, Mich. factory.

CRAFTSMAN Pedestal-type Tool Stands				Tool Stand Guards		
Catalog Number	Fits Tool	Wt. lbs.	Price	Catalog Number	Shpg. wt. lbs. Oz.	Price
(1) 99 M 2957L	2-wheel Band Saw—99M2425L . . .	51	\$26.95	9 M 2907	4 4	..\$5.69
(2) 99 M 2223L	3-wheel Band Saw—99M2455L . . .	49	23.95	9 M 2907	4 4	.. 5.69
(3) 99 M 2226L	Wood Shaper—99M2392N	41	23.95	..None..
(4) 99 M 2204L	6-in. Sander—99M2250L	49	25.95	9 M 2251	2 13	..5.79
(5) 99 M 2959L	4½-in. Jointer-Planer—99M2186L54	54	24.50	9 M 2907	4 4	.. 5.69
(6) 99 M 2228L	10-in. Bench Saw—99M2999N . . .	61	27.95	..None..
	9-in. Bench Saw—99M2000NNone..
	8-in. Bench Saw—99M2104LNone..
(7) F99 M 2224L	Thickness Planer—99M2370N . . .	54	23.95	..None..
(8) 99 M 20687L	4¾-in. Jointer-Planer—99M2067N .	55	26.95	9 M 29115	4 5	.. 5.29
(9) 99 M 29602N	6½-in. Jointer-Planer—99M2061N .	77	34.95	9 M 29082	4 8	.. 6.98
(10) 99 M 2249N	Wood Turning Lathe 99M2160L, 99M2388L or 103.23870	72	31.50	..None..
(11) F99 M 2958L	18-in. Jig Saw—99M2072N	52	22.50	9 M 29115	4 5	.. 5.29

Casters for Tool Stands above. Set of four heavy-duty, easy-rolling steel casters. Easy to install in base. Order a set for each stand in your shop. Makes power tool moving a snap. 9 M 2819—Shipping weight 1 pound per set Set of 4 for \$4.69



CRAFTSMAN Steel Bench

REG. U. S. PAT. OFF.

Keep your shop organized with a CRAFTSMAN Steel Work Bench. Makes it easier for you to work . . . provides a center for most of your shop work.

Bench, drawers and power-strip were especially developed and designed for use in every type workshop . . . large or small. They're ideal for factories, machine shops, farm shops, home workshops, etc. You'll do better work, faster and easier, in a shop that is well organized. Check the advantages of the CRAFTSMAN Bench and Accessories . . . you get more for your "shop dollar."

CRAFTSMAN Steel Work Bench. Solid side panel ends . . . heavy duty all-steel construction, cross-braced in back for greater rigidity. Steel legs adjust for uneven floors. Bench accommodates 10 drawers to provide for easy tool storage. Pressed, bonded wood top; SOLID—harder than maple! Laminated on both sides. Resists oil and grease; smooth surface resists warping. Top size: 60x24x1½ in. overall; 34 in. high. Will accommodate woodworking vise at either end. Bronze finish. Bolts, nuts needed for assembly included. Drawers, Power-Strip not included.
99 M 1023N2M—Shipping weight 104 pounds \$29.95

Steel Drawers. (10 shown on bench.) Handy storage for your small tools, etc. Designed to fit CRAFTSMAN Work Bench above; matching bronze finish. Inside dimensions; 16¾ in. left to right; 4 in. top to bottom; 16½ in. front to back.
99 M 1062CM—Shipping weight 9 pounds Each \$4.79

Without drawers or Power-Strip
\$29.95
cash
\$3 down

CRAFTSMAN Power-Strip. (Shown on Steel Tool Bench above.) Features convenience of electrical outlets plus safety of built-in circuit breaker. Power-Strip has a multitude of applications. Mounts easily on work benches for portable tools, soldering irons, etc. Also for power tools, trouble lights, etc. Prevents overloading of stalled motors and eliminates going to fuse box for restoring current. Once trouble is corrected, the flip of the switch returns current to Power-Strip. Mounts practically anywhere . . . vertically, horizontally, along baseboards. Three power receptacles . . . built-in 15 ampere circuit breaker. On-off switch. 36 in. long. For AC only.
99 M 2130C—Shipping weight 4 lbs. . . \$6.98

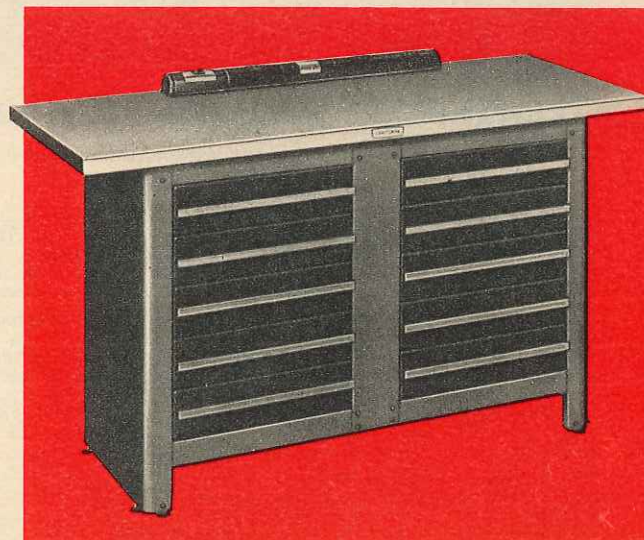

Order any stand or bench on this page for 10% down on Sears Easy Terms

Without motor
\$65.95
 cash
\$5 down

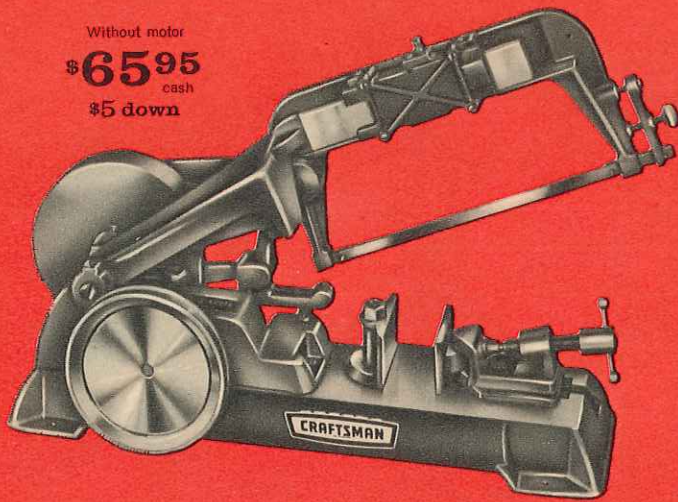

CRAFTSMAN Reciprocal-type Hack Saw

REG. U. S. PAT. OFF.

Semi-automatic for "hands-off" working

SPECIFICATIONS:

- Capacity, maximum 4x4 inches
- Angle cuts 90 to 45 degrees
- Bearings porous bronze
- Machine pulley (included) 6½ in.
- Motor pulley (not included) 2 in.
- Motor recommended, min. ½ HP
- Base size 6x24 inches
- Mounting dimensions 5½x19⅞ in.
- Stroke 5 in.; 60 strokes per minute at 400 RPM

Cuts accurately while you work on other jobs. Draw-out type . . . automatic relieving mechanism lifts blade from work on back stroke. Cuts any shape iron, brass, aluminum, etc. up to 4x4 inches at 90°. Makes angle cuts 90° to 45°.

Heavy cast iron vise is quick locking. Cast semi-steel slide and arm. Cone-type arm pivot is adjustable. Takes any standard 12-inch power hack saw blade (one included). For extra blades see 9 M 6582 listed below.

99 M 2294L—Without motor, motor pulley, or V-belt. Shipping weight 57 lbs. \$65.95
 99 M 22945L2—With CRAFTSMAN ½-HP 1725 RPM split-phase motor for 110-120 volt, 60-cycle AC and 2-inch motor pulley with ½-in. x 42 in. V-belt. Shipping weight 82 lbs. 84.00

CRAFTSMAN 12-inch Power Hack Saw Blades for above. Special alloy steel. ⅜ inches wide. Choice of 14 or 18 teeth per inch. Please state teeth per inch on order.
 9 M 6582—Shipping weight 5 ounces. 2 for \$1.69

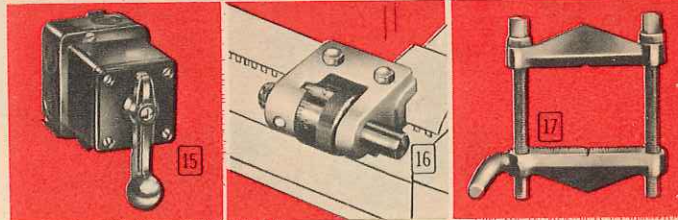
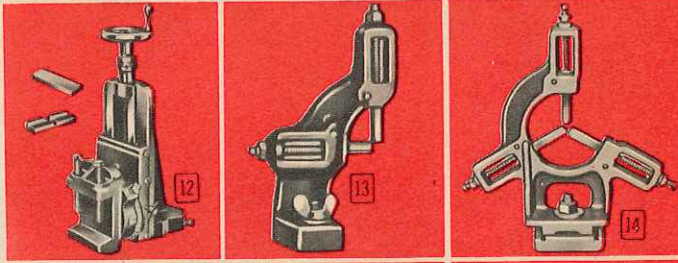
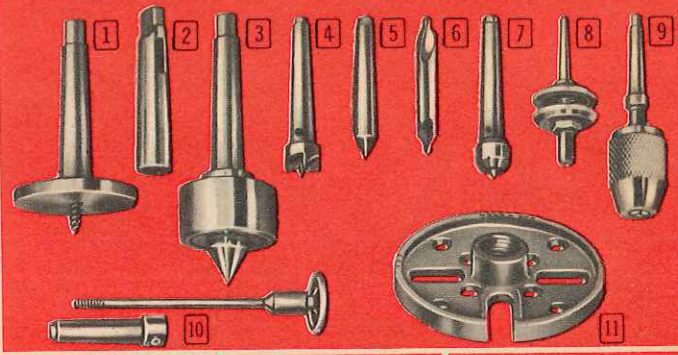

Accessories for CRAFTSMAN 6-inch Metal Turning Lathe on opposite page

- 1 Screw Centers.** For facing and hollowing. Removable center.
 9 M 2116—No. 1 Morse taper shank. Shipping weight 12 ounces. \$1.79
 9 M 2115—No. 2 Morse taper shank. Shipping weight 14 ounces. 1.89
- 2 Adapter Sleeve.** Reduces No. 2 Morse taper to No. 1 Morse taper.
 9 M 2161—Shipping weight 5 oz. \$2.29
- 3 Precision ball-bearing 60-degree Center.** (Center point rotates on ball bearings.) For high-speed operations.
 9 M 2112—No. 1 Morse taper shank. Shipping weight 8 ounces. \$3.49
 9 M 2113—No. 2 Morse taper shank. Shipping weight 10 ounces. 3.49
- 4 Spur Centers.** For wood turning.
 9M2106—No. 1 Morse taper shank. Shipping weight 4 ounces. \$1.29
 9 M 2107—No. 2 Morse taper shank. Shipping weight 7 ounces. 1.49
- 5 60-degree Centers.** For turning metal and hardwoods.
 9 M 2110—No. 1 Morse taper shank. Shipping weight 4 ounces. 98c
 9 M 2111—No. 2 Morse taper shank. Shipping weight 6 ounces. \$1.09
- 6 High Speed Center Drill.** Choice of ⅜-inch size (⅝-inch body) or ⅞-inch size (¾-inch body). State size wanted.
 9 M 2060—Shipping weight 2 oz. 98c
- 7 Tailstock Cup Centers.** Supports work in tailstock. Removable center point.
 9 M 2100—No. 1 Morse taper shank. Shipping weight 4 ounces. \$1.29
 9 M 2101—No. 2 Morse taper shank. Shipping weight 7 ounces. 1.49
- 8 Work Arbor.** For mounting chucks and holding grinding, buffing and wire scratch wheels, etc. ½-in. x20-thread, 2 steel flanges with nut on head end for clamping wheels. Morse taper shank.
 9 M 2152—No. 2 Morse taper shank. Shipping weight 11 ounces. \$1.49
 9 M 2153—No. 1 Morse taper shank. Shipping weight 9 ounces. 1.49
- 9 Work Arbor with Chuck.** Three-jaw, screw-on type chuck, tapped ⅜-inch x 20 thread; ⅜-inch capacity. Work arbor has Morse taper on shank end. Shipping weight 1 lb. 8 oz.
 9 M 2247—No. 2 Morse taper shank. \$2.85
 9 M 2234—No. 1 Morse taper shank. 2.85
- 10 Holding Collet.** Fits headstock; holds threaded-hole, angular milling cutter, keyway cutters and ⅜-in. end mills. Use with arbors F9 M 1566, F9 M 1567 (page 40).
 9 M 21408—Shpg. wt. 1 lb. 10 oz. \$9.70
- 11 Face Plate.** Use for driving lathe dog and wood turning work. 5¼-inch diameter. For use on 99 M 2140N lathe (on opposite page) and other lathes with 1-inch, 10-thread spindle.
 9 M 21405—Shipping wt. 3 lbs. \$5.50
- 12 Milling Attachment.** Graduated swivel vise, flat block and V-block for holding cylindrical objects. Vise capacity 2 in.; vertical feed ⅜ in.; cross feed 3⅜ in. Graduated angular swivel.
 9 M 2057—Shpg. wt. 8 lbs. 6 oz. \$34.65
- 13 Follower Rest.** Mounts on back of carriage dovetail slide . . . moves with cutting tool to provide support needed to prevent deflection when turning long, slender work.
 9 M 2042—Shpg. wt. 2 lbs. 2 oz. \$7.80
- 14 Steady Rest.** Base clamps securely to bed ways. Gives added support needed when turning long pieces. Handles diam. up to 2⅝ in. Bronze jaws.
 9 M 2041—Shpg. wt. 2 lbs. 8 oz. \$10.25
- 15 Reversing Switch.** Reverses motor and spindle direction in grinding, polishing, tapping, wood or metal finishing. Complete instructions.
 9 M 2982—Shpg. wt. 1 lb. 9 oz. \$7.49
- 16 Carriage Stop.** Clamps to bed-way of 6-inch or 12-inch lathes. Shp'd. from Kalamazoo, Mich. Fcty.
 F9 M 2185—Shpg. wt. 2 lbs. \$8.40
- 17 Clamp Dog.** Handles any shape work. Jaws open 2¼ inches. Shipped from Kalamazoo, Mich. Factory.
 F9 M 1512—Shpg. wt. 1 lb. \$7.35

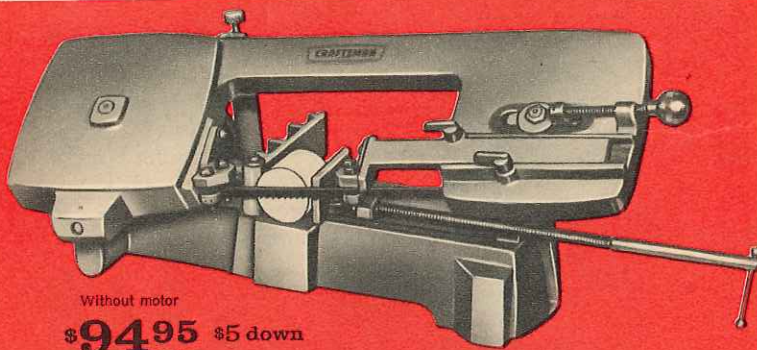

Without motor
\$94.95 \$5 down
 cash

CRAFTSMAN Continuous Blade Hack Saw

REG. U. S. PAT. OFF.

Cuts 10 times faster than reciprocal-type

SPECIFICATIONS:

- Capacity, maximum 3x6 inches
- Angle cuts 90 to 45 degrees
- Bearings bronze and steel
- Machine pulley (included) 6 in.
- Motor pulley (included) 2 in.
- Motor recommended ½ HP
- Base size 22⅞x6⅜ inches
- Mounting dimensions 5½x19⅞ in.
- Blade ⅜ in. wide, .020 inch thick, 60 in. long, 14 teeth per inch

Cuts through 2-in. round, cold rolled steel in 2¾ minutes. Zips through any shape steel, cast iron, brass, aluminum, etc. Continuous cutting . . . no lost motion as on return stroke of reciprocal saws. Speed of feed adjusts through hydraulic control. Quick-action vise accommodates different work sizes. Stationary vise adjusts angle cuts. Saw blade adjusts through adjustable guide rollers. Nylon pinion for quiet operation. Blade speed 135 ft. per minute. ⅜-in. bore pulley. Use with CRAFTSMAN ½-HP, 1725 RPM Split-phase Motor. See index for page number.

99 M 2292L—With motor pulley, without motor or V-belt. Shpg. wt. 70 lbs. \$94.95

Extra Blades. For hack saw above.

9 M 22926—10 teeth per inch. Shipping weight 6 ounces. Each \$2.98
 9 M 22927—14 teeth per inch. Shipping weight 6 ounces. Each 2.98
 9 M 22928—Skip-tooth (4 teeth per inch). Shipping weight 6 ounces. Each 2.98

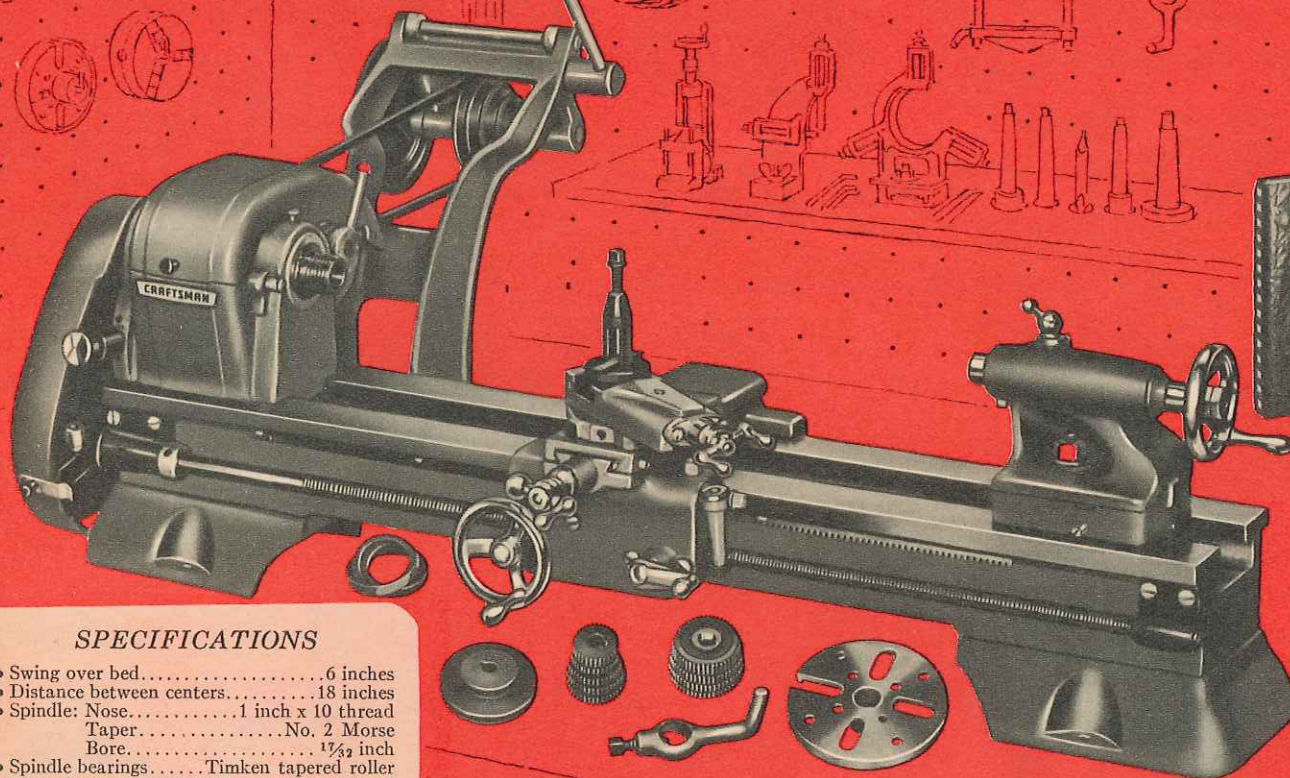

SPECIFICATIONS

- Swing over bed.....18 inches
- Distance between centers.....16 inches
- Spindle: Nose.....1 inch x 10 thread
Taper.....No. 2 Morse
Bore..... $1\frac{1}{2}$ inch
- Spindle bearings.....Timken tapered roller
- Thread range.....8 to 96, right or left hand
- Bed.....1-piece cast semi-steel
- Carriage...hand wheel for manual operation;
feed lever for reversible automatic
longitudinal power feed
- Feeds....Four: .0024, .0039, .0048 and .0078
- Back gear ratio.....approximately $6\frac{1}{2}$ to 1
- Countershaft, back gear
bearings.....4 porous bronze
- Swing over carriage..... $3\frac{1}{2}$ inches
- Compound rest travel..... $1\frac{1}{4}$ inches
- Cross slide travel..... $4\frac{3}{4}$ inches
- Tailstock taper.....No. 1 Morse
- Tailstock ram travel..... $1\frac{1}{4}$ inches
- Tailstock setover..... $\frac{3}{16}$ inch
- Motor recommended,
(minimum)..... $\frac{1}{4}$ HP, 1725 RPM
- Machine pulley (included).....4-step
- Motor pulley (included).....2-step
- Mounting dimensions..... $4\frac{3}{4}$ x $27\frac{1}{16}$ inches
- Overall dimensions: Height 12 inches; width
27 inches; length $33\frac{1}{2}$ inches

CRAFTSMAN 6-in. Metal Turning Lathe

\$175.00
cash

REG. U.S. PAT. OFF.

Timken tapered roller bearings assure long-life operation

without motor
\$5 down

For precision work—here's a metal lathe that's *guaranteed accurate within 1/1000 inch*. It actually matches our larger lathes in precision and accuracy. Compare features and specifications at left with other metal lathes in the same price range . . . you'll find CRAFTSMAN is the lathe for you!

Designed, built and priced for toolmakers, model makers and hobbyists, the CRAFTSMAN 6-inch metal turning lathe is of true professional quality.

Complete operating instructions show you how to get the job done right and as quickly as possible. Entire outfit includes 258-page Lathe Manual described at right and all accessories shown above. Accessory group includes the following items: 2-step motor pulley, 4-step machine pulley, 4-step quick-change

countershaft, two 60-degree centers, $\frac{3}{16}$ -inch tool bit, 9 threading gears, 1-inch lathe dog, $\frac{3}{8}$ -inch V-belt, two Allen wrenches, $5\frac{1}{4}$ -inch face plate and two standard-dimension wrenches.

Motor not included. We suggest that you use at least a $\frac{1}{4}$ -HP 1725 RPM motor.

99 M 2140N—Shipping weight 100 pounds.....\$175.00

Metal Lathe Manual. Complete, up-to-date manual of metal lathe operations and machinists' tables. Easy-to-follow directions on the operation of a metal lathe. Filled with actual photographs and drawings. Index tabs for quick reference. Paper bound. 258 pages chock-full of useful information.

9 M 2925—Shipping weight 1 pound 4 ounces.....\$2.50

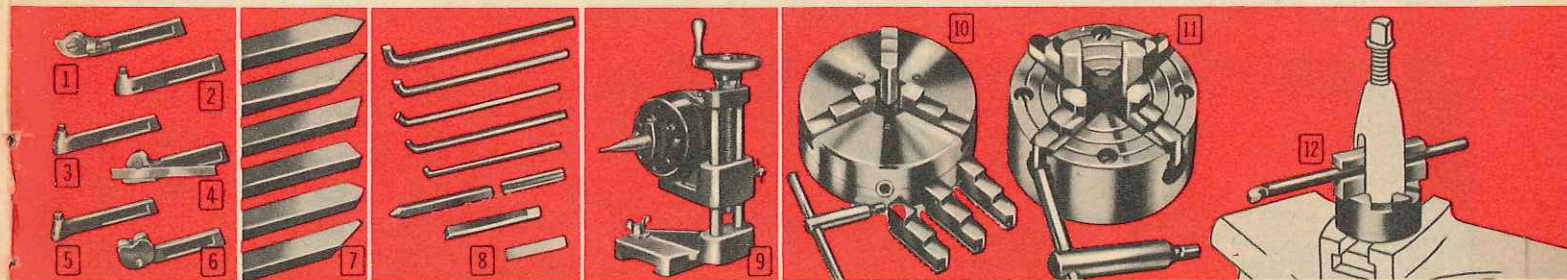

Tool Holders

Fit 99M2140N Lathe above. Special drop forged steel, expertly heat treated, hardened.

- 1 9M2031—Threading Tool. Shpg. wt. 10 oz.....\$6.29
- 2 9M2035—Left-hand Tool Holder. No bit. Shipping weight 8 oz.....\$2.69
- 3 9M2033—Straight Tool Holder. No bit. Shipping weight 8 oz.....\$2.69
- 4 9M2037—Cutoff Tool. Shipping wt. 10 oz.....\$3.79
- 9 M 2009—Extra Cutoff Blade. Shpg. wt. 2 oz.... 1.29
- 5 9M2034—Right-hand Tool Holder. No bit. Shipping weight 8 oz.....\$2.69
- 9 M 2036—Knurling Tool. Shpg. wt. 10 oz.... 7.49

Formed Tool Bit Set

- 7 Six-piece set of $\frac{3}{16}$ -inch tool bits. High speed tool steel; ground, ready to use. Set includes threading bit, left-hand facing bit, left-hand turning bit, right-hand turning bit, right-hand facing bit, and round nose turning bit. Shipping weight 3 ounces.
- 9 M 2043—6-piece set....\$2.69

Tool Post Set

- 8 High speed tool steel. Tools mount directly in tool post. Set includes the following: 4 boring bars, internal threading tool, external threading tool, external turning tool, and a set of tool post spacers for height spacing. Shipping weight 2 pounds 2 ounces.
- 9 M 2038—Set.....\$13.60

Mica Undercutter

- 9 For reconditioning armatures on 6-inch Lathe above. Screw feed regulates height of cutter; carriage feed moves cutter into commutator slot. For 110-120-volt, 25-60-cycle AC-DC. Complete with motor, switch, cord and 5 undercutting saws. \$5.00 down, \$5.00 monthly. Shipping weight 9 lbs.
- 9 M 1518.....\$56.75

Set of 10 Replacement Saws for above. Shipping weight per set, 1 pound. Shipped from factory in Kalamazoo, Michigan.

F9M1519....Set \$.95

CRAFTSMAN Lathe Chucks

- 10 3-jaw universal type. Jaws controlled by single screw and pinion gear... speedy gripping... self-centering... ideal for production work. Extra-strong semi-steel body casting. Special alloy metal scroll; alloy steel pinion. Alloy steel jaws. Fits the 99 M 2140N lathe above, or any 1-inch x 10-thread spindle, 4-inch diameter. Has two sets of jaws (outside and inside).
- 11 4-jaw independent type. For average shop needs. Special alloy steel body has wide, deep jaw slots. Four reversible jaws work independently; increase usefulness when working on irregular shaped pieces. Large-diameter jaw screw. Acme threaded. Fits 99 M 2140N metal turning lathe above, or any 1-inch x 10-thread spindle. Diameter 4 inches.

With T-handle wrench, Shipping weight 5 pounds 3 ounces.

Only \$4.50 down, \$5.00 monthly, on Sears Easy Terms.

9 M 21407.....\$41.50

9 M 21406....\$11.59

Tool Holder

- 12 Boring Tool Holder. Complete with clamp ring, V-block, plain block and $\frac{1}{4}$ -inch high speed boring tool. Slots hold boring tools of $\frac{3}{16}$, $\frac{1}{4}$, $\frac{5}{16}$ and $\frac{3}{8}$ -inch diameter.

Order now at Sears low price!

Shipped from factory in Kalamazoo, Michigan. Shipping weight 1 pound.

F9 M 1515.....\$6.25

Why not buy your lathe with all needed accessories on Sears Easy Terms? See inside back cover for details.

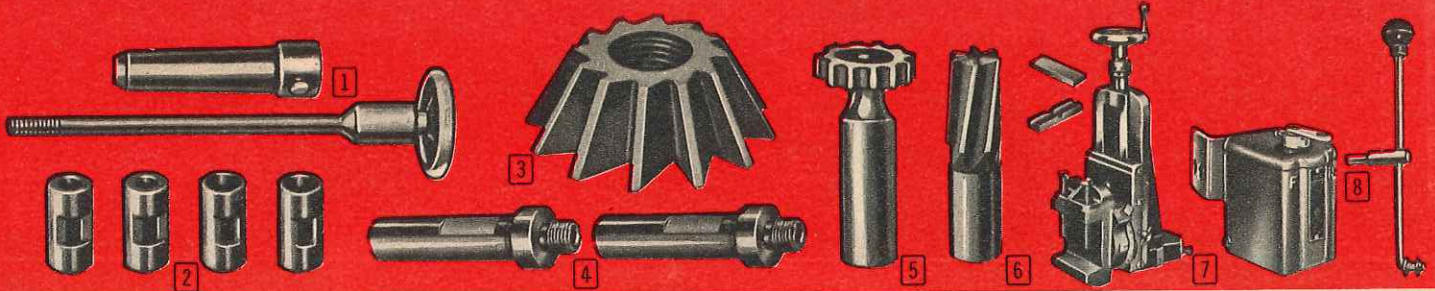

Milling and Lathe Accessories for CRAFTSMAN Lathes

REG. U.S. PAT. OFF.

1 **Milling Holder Set.** For use with straight shank milling cutters and adapters. A strong, rugged and long lasting collet. Includes hand wheel for easy adjustment. Add milling accessories to your easy terms order.
9M29945—Wt. 2 lbs. 8 oz. \$11.30

2 **End-mill Bushings.** Are required to adapt all end mills F9M2997 (see (6) at right), except for 1/2-inch diameter size, to Milling Holder Set 9M29945 shown above. Strongly built for long life and dependability. Guaranteed against defects in materials and workmanship.
9 M 2985—Wt. 8 oz., Set of 4 \$3.15

3 **Angular Cutters.** For face milling and dovetailing. Threaded hole adapted to milling holder set 9 M 29945 (see (1) at left) with arbors listed below. Shipping weight each 1 lb. *State thickness.*
F9 M 2995—1/16 in. (1 1/4-in. diam., 3/8-in. hole).....\$10.25
1/16 in. (1 1/8-in. diam., 1/2-in. hole)..... 11.45

4 **Arbors for Angular Cutters.** Arbors are required to hold angular cutters F9 M 2995 (see (3) above) in milling holder set 9 M 29945 (see (1) at left). Shipping weight each 1 pound.
F9 M 1566—For 1/16-inch Angular Cutter, 24-thread.....\$2.90
F9 M 1567—For 3/16-inch Angular Cutter, 20-thread..... 2.90

5 **Woodruff Keyway Cutters.** 1/4-inch shank. F9 M 2996—Shipping weight 1 lb. *State diameter.*

Diameter	Thickness	Price
1/2 inch.....	1/8 inch.....	\$4.75
3/4 inch.....	3/16 inch.....	5.20
1 inch.....	1/4 inch.....	6.45
1 1/8 inches.....	5/16 inch.....	7.60
1 1/2 inches.....	3/8 inch.....	8.55

6 **R.H. Spiral End Mills.** For slots, straight keyways, facing, routing, squaring, splining shafts. Held in milling holder set 9 M 29945 ((1) at left) with bushings 9 M 2985 ((2) at left). *State diameter.*

Diameter	Length Flute	Shpg. wt.	F9 M 2997
1/4 inch.....	3/8 inch.....	1 lb.....	\$3.80
3/8 inch.....	1/2 inch.....	1 lb.....	4.00
1/2 inch.....	3/4 inch.....	1 lb.....	4.30
3/4 inch.....	1 inch.....	1 lb.....	4.50
1 inch.....	1 1/8 inch.....	1 lb.....	5.00

7 **Milling Attachment.** This strong, rugged and dependable device consists of a graduated swivel vise, a flat block for cylindrical work, and a V-block for cylindrical work. Capacity of vise: holds objects with thickness of up to 2 3/4 inches. Vertical feed 3 3/4 inches. Buy milling accessories on Sears Easy Terms. Shipping weight 18 pounds.
99 M 2987C—\$4.50 down..... Cash \$41.75

8 **Reversing Switch.** Made for lathe on opposite page. With capacity of up to one HP. Takes voltages up to 550 volts, both single and three-phase circuits. Comes with power cord and installation and operating instructions. Use to operate lathe in reverse.
9M2018—Shipping wt. 4 lbs. 2 oz.....\$17.60

Note: See Special Shipping Notice below

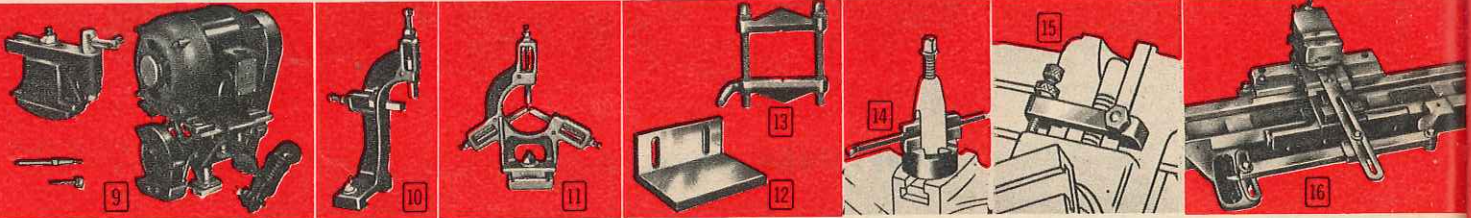

9 **Lathe Grinder.** A universal tool post grinder. Mounts on side of compound rest. Grinds at two different speeds: 4900 and 9100 RPM. With 1/4-HP 3450 RPM motor. Operates on 110-120 volt, 25-60 cycle AC current. Uses both external and internal grinding wheels (see grinding wheel listings below); quill, diamond wheel dresser. Shipping weight 65 pounds.
F99 M 2998L—\$5.00 down, \$6.00 month.....Cash \$120.75

Grinding Wheels. For use on Lathe Grinder F99 M 2998L (shown above). Include wheels for grinding steel and iron, and wheels for interior as well as exterior use. Medium grit. Shipping weight each wheel 1 pound.

Catalog No.	Type and size of wheel	Price
F9 M 1501.....	External, for steel, 4-in. diam., 3/8 in. thick.....	\$3.40
F9 M 1502.....	External, for cast iron, 4-in. diam., 3/8 in. thick.....	3.65
F9 M 1503.....	Internal, grinding depth 2 3/8 in., 1/4-in. diameter.....	1.35
F9 M 1504.....	Internal, grinding depth 2 3/8 in., 1/2-in. diameter.....	1.35
F9 M 1505.....	Internal, grinding depth 2 3/8 in., 3/4-in. diameter.....	1.40
F9 M 1506.....	Internal, grinding depth 2 3/8 in., 1-in. diameter.....	1.55

10 **Follower Rest.** Mounts on back of carriage slide; designed to provide support to work being done on lathe.
9 M 2988—Shpg. wt. 3 lbs. 4 oz.....\$8.55

11 **Steady Rest.** Clamps to bed ways; with hinge-type bronze jaws. Sturdy and solid. Handles diameter to 2 1/2 inches.
9 M 20506—Shpg. wt. 8 lbs.....\$15.49

12 **Angle Plate.** Simplifies off-center work and machining of oddly shaped pieces. Bolts to face plate. Horizontal face 6x4 3/4x3 3/8 inches; vertical face 6x2 3/8x3 3/8 inches.
F9 M 1509—Shpg. wt. 10 lbs.....\$9.50

13 **Clamp-type Dog.** Holds square, rectangular, hexagonal or round work. Opens to 2 1/4 inches.
F9 M 1512—Shpg. wt. 1 lb.....\$7.35

14 **Boring Tool Holder.** With clamp ring (has 1 3/4-inch outside diameter, 1 1/16-inch inside diameter), V-block and plain block; one 1/4-inch boring tool. Clamp ring has three slots to hold 3/16, 1/4, 5/16, 3/8-inch diameter tools. Guaranteed against defects in materials, workmanship.
F9 M 1511—Shpg. wt. 1 lb.....\$6.50

15 **Cross Slide Stop.** Designed to show depth to stop cross feed. Not intended to automatically stop cross feed. To install, clamp to dovetail.
F9 M 1510—Shipping weight 1 lb.....\$7.75

Accessories on these two pages for use on Lathe shown on opposite page and on previous models.

See Special Shipping Notice below

16 **Taper Attachment.** Eliminates moving tailstock out of alignment. Cuts duplicate tapers on pieces of different lengths. Does internal boring and external work. Index plate is graduated 7° and 3 inches on both sides of center line; equals 2 1/16-inch taper per foot right or left. Extremely accurate and dependable. Shpg. wt. 11 lbs. Guaranteed against defects in materials, workmanship. \$4.50 down.
9 M 29845.....\$40.45



\$6800 \$5 down
cash
F99 M 1596N

CRAFTSMAN Lathe Table

For CRAFTSMAN 12-inch lathes. Work height especially measured to give less fatigue. Legs of gray, heavy cast iron, thickly ribbed and crossbraced for extra strength. Thick hardwood table top, thoroughly seasoned, shellacked and varnished. Legs can be securely anchored to floor. Large bottom board is convenient for holding tools and accessories. Overall height 33 3/4 inches. Shipped freight (rail or truck) or express. (See factory shipping notice at right.)

F99 M 1596N—Fits lathe 45 inches long. Shpg. wt. 170 lbs. \$5.00 down.....Cash \$68.00
F99 M 1597N—Fits lathe 57 inches long. Shpg. wt. 180 lbs. \$5.00 down.....Cash \$73.00

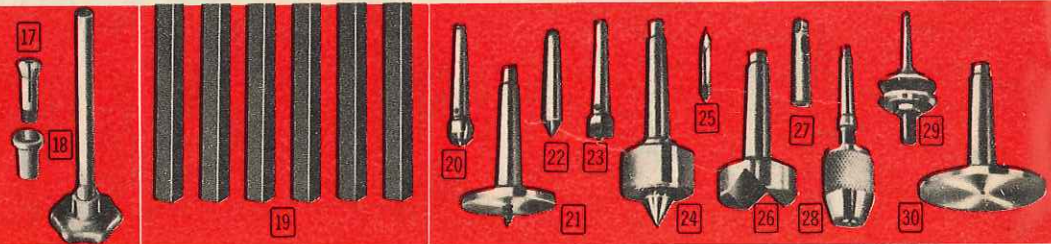

17 **Split Holding Collet.** For use in round chuck work. *Please state size.*
F9 M 1508—Shpg. wt. 1 lb.
1/2 inch.....\$11.75
1/16, 3/32 inch..... 8.75
1/8, 1/16, 3/16, 1/32, 1/4, 5/32, 3/16, 1/32, 3/8, 1/2, 5/8, 3/4, 7/8, 1 inch sizes. Each for.....\$5.75

18 **Draw-in Collet Chuck Attachment.** For chuck work from 1/2 to 1 1/2-inch diameter. Consists of hollow draw-in spindle with hand wheel control, tapered closing sleeve. Rods pass through lathe spindle; hand wheel tightens or releases collet. Shipping weight 3 lbs. \$3.00 down.
F9 M 1507.....Cash \$29.00

19 **CRAFTSMAN Unground Cutter Bits Sets.**
F9 M 1611—Set of 6 CRAFTSMAN Cutter Bits. 3/16-inch unground bits. Shpg. wt. 1 lb.....\$1.35
F9 M 1606—Set of 6 bits; 1/4-inch size. Wt. 2 lbs.....\$2.65
F9 M 1608—Set of 6 bits; 3/8-inch size (for tool post). Shipping weight 2 lbs.....\$6.00

All the accessories shown on these pages are guaranteed free from defects in materials and workmanship. If for any reason whatever you are not satisfied with the accessories you have purchased, we will exchange them for exactly what you want, or will refund your money.

20 **Tailstock Cup Center.** Supports work. Hard steel. Replaceable center point. No. 2 Morse taper. 9M2101—Shpg. wt. 7 oz. \$1.49

21 **Screw Center.** No. 2 Morse taper. 9M2115—Shpg. wt. 14 oz. \$1.89

22 **60° Center.** Has number 2 Morse taper. 9M2111—Shpg. wt. 6 oz. \$1.09

23 **Spur Center.** For wood. No. 2 Morse taper. 9M2107—Shpg. wt. 7 oz. \$1.49

24 **Precision Ball-bearing 60° Center.** For high speeds. Number 2 Morse taper. 9M2113—Shpg. wt. 10 oz. \$3.49

25 **High Speed Center Drill.** State 1/8 or 1/4-inch. 9 M 2060—Shpg. wt. 2 oz. 98c

26 **Crotch Center.** Centers around work in tailstock for cross drilling. 2-Morse taper. 9 M 2114—Shpg. wt. 1 lb.....\$1.89

27 **Adapter Sleeve.** To reduce No. 2 to 1 Morse taper. 9 M 2161—Shpg. wt. 5 oz.....\$2.29

28 **Work Arbor with Chuck.** 3 jaw; tapered 1/2-in. x 20-thread. No. 2 Morse taper. 9 M 2247—Wt. 1 lb. 8 oz.....\$2.85

29 **Work Arbor.** 1/2-in. x 20-thread. No. 2 Morse taper. For grinding wheels. 9 M 2152—Shpg. wt. 11 oz. \$1.49

30 **Drill Pad.** Used in tailstock for support. Diam. of face 3 1/2 in. No. 2 Morse taper. 9 M 2187—Wt. 1 lb. 2 oz.....\$2.29

Special Shipping Notice: All items with catalog number beginning with "F" shipped from factory in Kalamazoo, Mich.

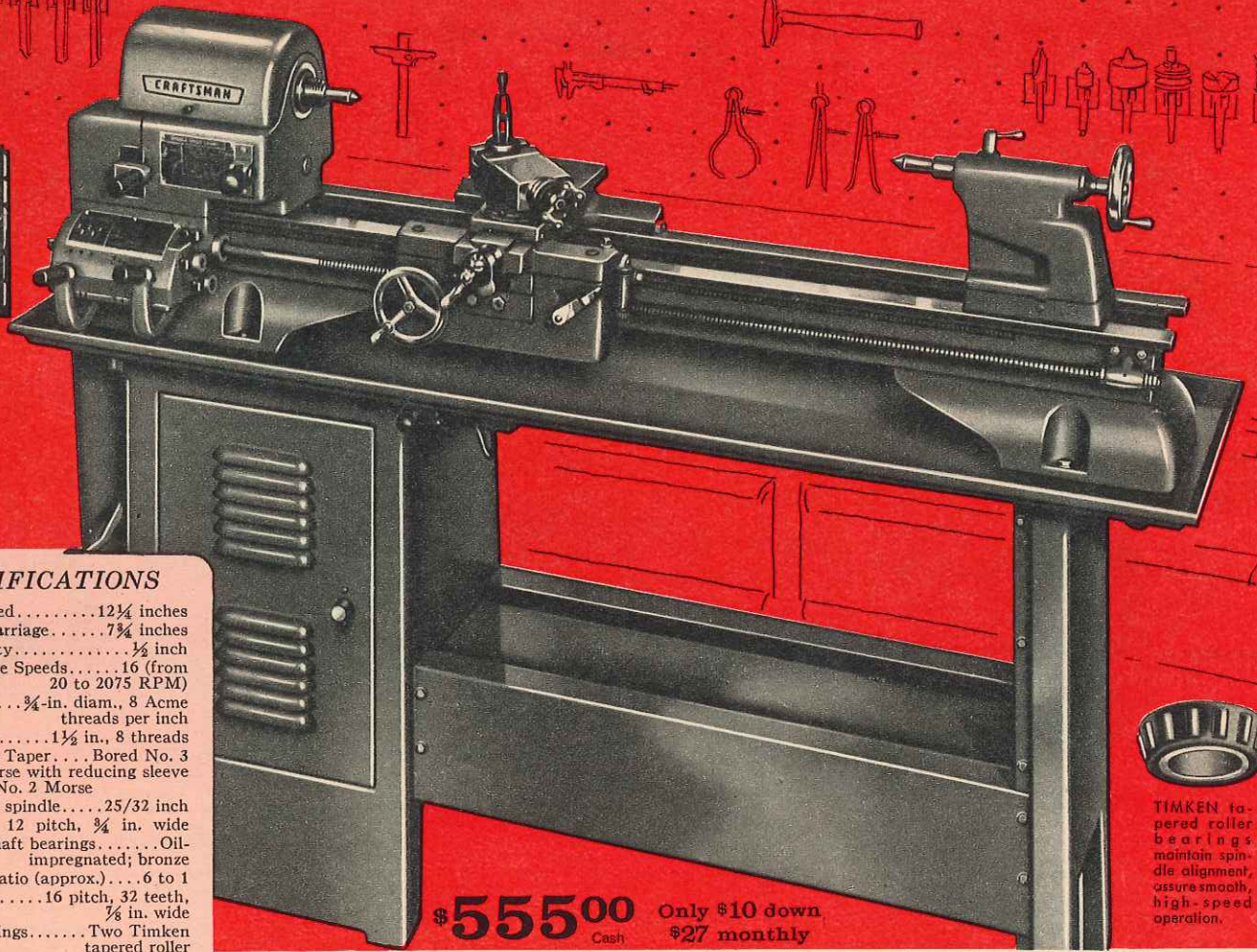

SPECIFICATIONS

- Swing over bed 12 1/4 inches
- Swing over carriage 7 3/4 inches
- Collet capacity 1/2 inch
- No. of Spindle Speeds 16 (from 20 to 2075 RPM)
- Lead Screw 3/4-in. diam., 8 Acme threads per inch
- Spindle Nose 1 1/2 in., 8 threads
- Spindle Nose Taper Bored No. 3 Morse with reducing sleeve to No. 2 Morse
- Hole through spindle 25/32 inch
- Back Gears . 12 pitch, 3/4 in. wide
- Back Gear shaft bearings Oil-impregnated; bronze
- Back Gear Ratio (approx.) 6 to 1
- Spindle Gear 16 pitch, 32 teeth, 7/8 in. wide
- Spindle Bearings Two Timken tapered roller
- Tailstock Ram 1 1/2-in. diam.
- Tailstock Ram travel 2 3/4 in.
- Tailstock Ram graduations 0 to 3 in. by 1/16 in.
- Tailstock Setover, forward or back 3/4 inch
- Cross Feed travel 6 1/2 inches
- Cross Feed Screw 1/2-in. diameter Acme threaded
- Compound Rest travel 2 3/8 inches
- Tool Post 3/4 x 7/8-in. slot to take 3/8-in. tool bits or tool holder for 1/4-in. tool bits
- Compound Rest Swivel. Graduated 0 to 90° right and left
- Motor recommended 3/4 or 1/2 HP 1725 RPM
- Motor Pulley (included). 4 1/2 inch; 2 step 3/8-in. bore
- Countershaft bearings 2 ball; 2 oil-impregnated; bronze
- V-Belts A-section 1/2 inch wide
- Drive Pulley (included) 3-inch diameter, dual pulley

\$555.00 Only \$10 down
Cash \$27 monthly



TIMKEN tapered roller bearings maintain spindle alignment, assure smooth, high-speed operation.

Our Finest CRAFTSMAN Metal Turning Lathe

REG. U.S. PAT. OFF.

12-inch Floor Model Cabinet Lathe with underneath drive

Built for heavy duty . . heavy for great accuracy . . heavy for smooth, quiet, chatter-free operation.

Features a floor-type cabinet of welded 3/16-inch steel plate . . . a rigid mount for accurate work. Drive is completely enclosed in the cabinet and is within easy reach through a door in the front. Slots in cabinet provide for adjusting countershaft and motor for proper belt tension.

Lathe has a cast semi-steel bed; precision-ground ways. Timken roller bearings in the headstock maintain spindle alignment and carry radial and thrust loads with a minimum of friction. Spindle nose has a No. 3 female Morse taper reduced to No. 2. Reversible power cross feed makes facing work easier. Lever for automatic power feed.

Lathe includes micrometer-type dials, dial locks with large knurled collars, speed chart conveniently located on the front of the headstock. 60-hole indexing mechanism on headstock. All gears in apron made of cut steel.

For further details see specification table at left.

Lathes with Quick Change Gear Attachment (99 M 2893N, 99 M 2894N, 99 M 2895N, 99 M 2897N) provide selection of 54 threads or feeds. Pulley, V-belt, two 60° centers, tool post wrench, hex wrench. 258-page Lathe Manual gives helpful instructions on the operation and care of these CRAFTSMAN metal turning lathes (see above).

99 M 2895N—24-in. centers. Cabinet, underneath drive, and quick-change. 50 3/4 in. Wt. 505 lbs. \$10.00 down, \$27.00 mo. Cash \$555.00
99 M 2897N—36-in. centers. Cabinet, underneath drive, and quick-change. 62 3/4 in. Wt. 545 lbs. \$10.00 down, \$29.00 mo. Cash \$595.00
99 M 2893N—24-in. centers. As above, but without cabinet. 45 in. long. Wt. 350 lbs. \$10.00 down, \$20.00 monthly. Cash \$425.00
99 M 2894N—36-in. centers. Like 99M2893N (without cabinet). 57 in. long. Shpg. wt. 372 lbs. \$10.00 down, \$22.00 monthly. Cash \$465.00

Two lathes below without Quick-change Gear Attachment or cabinet, but have 10 threading gears; cut 4 to 96 threads per inch, right or left (standard); metric .5 to 7.0 mm. Five feeds: .0024; .0035; .005; .0071; .0087 inches.

99 M 2758N—24-in. centers; 45 in. long. Shipping weight 335 pounds. \$10.00 down, \$16.00 monthly. Cash \$340.00
99 M 2759N—36-in. centers. 57 in. long. Shipping weight 357 pounds. \$10.00 down, \$18.00 monthly. Cash \$380.00

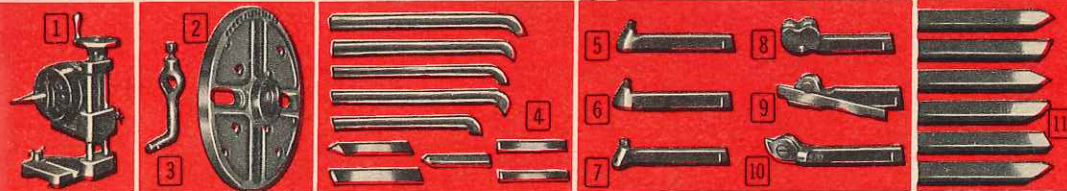

- 1** Mica Undercutter. Fastens to back of carriage. Screw feed regulates height of cutter. Carriage feed moves cutter into commutator slot. For 110-120 volt, 25-60-cycle AC-DC. With motor, switch, cord and set of five undercutting saws. Shpg. wt. 11 lbs. 9 M 2989—\$5.00 down. Cash \$56.70
- 10** High-Speed Saws. Use with 9 M 2989. From factory in so. Michigan. 2 each .015, .020, .025, .030, .035 in. thick. F9 M 1519—Shpg. wt. 1 lb. Set \$3.95
- 3** Lathe Dog. Forged steel. Heat-treated set screw. Shipping weight each 14 ounces. 9 M 2183—State size wanted.
Size 1/2 in. | 3/4 in. | 1 in. | 1 1/2 in.
Each \$1.30 | \$1.60 | \$1.85 | \$2.05

- 2** Face Plate. For work which cannot be machined on center or in chuck. 8 3/8-inch diameter. For 99 M 2758N, 99 M 2759N, 99 M 2893N, 99 M 2894N, 99 M 2895N, and 99 M 2897N (above) and other lathes with 1 1/2-inch 8-thread spindle. Mounts solidly on headstock spindle. Made of cast iron; with slots to engage lathe dogs. 9 M 24755—Shipping weight 7 lbs. . \$9.80
- 4** Tool Post Set. Fits lathes above. Includes four boring tools (3/16, 3/8, 5/16 and 3/8 in.); 1/4-inch inside threading tool; 3/8-in. turning tool; 3/8-in. threading tool; set of tool post spacers. 9 M 2189—Shpg. wt. 2 lbs., 2 oz. . \$14.65

- Tool Holders. Fit metal turning lathes above. Special drop-forged steel. For use with 3/4-in. tool bits 9M2205 below. Shanks 3/4 in. high; 3/8 in. wide.
- (5) 9 M 2196—Straight. Wt. 10 oz. . \$3.19
 - (6) 9 M 2194—Offset, left. Wt. 10 oz. 3.19
 - (7) 9 M 2192—Offset, right. Wt. 10 oz. 3.19
 - (8) 9 M 2202—Knurling tool. Wt. 13 oz. 7.98
 - (9) 9 M 2200—Cut-off. Wt. 12 oz. . . 4.19
 - (9) 9 M 2238—Extra blade. Wt. 4 oz. 1.39
 - (10) 9 M 2198—Threading. Wt. 12 oz. . 6.79

- 11** 6-piece Formed Tool Bit Set. 1/4-in. high-speed cutter bits; ground, for metal turning lathes. Fit tool holders above. Includes threading bit, left and right-hand facing bits, left, right-hand turning bits, round-nose turning bit. 9 M 2205—Shipping weight 5 oz. . . \$2.69

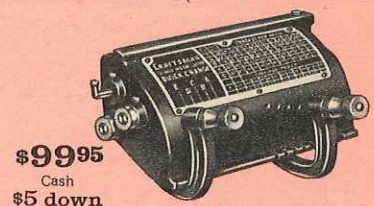

\$99.95
Cash
\$5 down

Quick-change Gear Attachment fits lathes, model numbers 101-.07361, .07362, .07363, .07381, .07382, .07383, .07401, .07402, .07403. State lathe model number when ordering.
Instant selection of 54 threads or feeds: between .0042 and .250 inch per revolution of spindle and all right or left-hand threads from 4 to 240 in the following standards: National Coarse (USS), National Fine (SAE), Acme, Square and Whitworth. No drilling or tapping to mount. Replaces gear change assembly.
99 M 2014K—Shpg. wt. 40 lbs. \$99.95
99 M 20145K—As above, but fits CRAFTSMAN lathes 99M2758N and 99M2759N above. Shipping weight 35 lbs. \$99.95

Buy your lathe and accessories on Sears Easy Terms

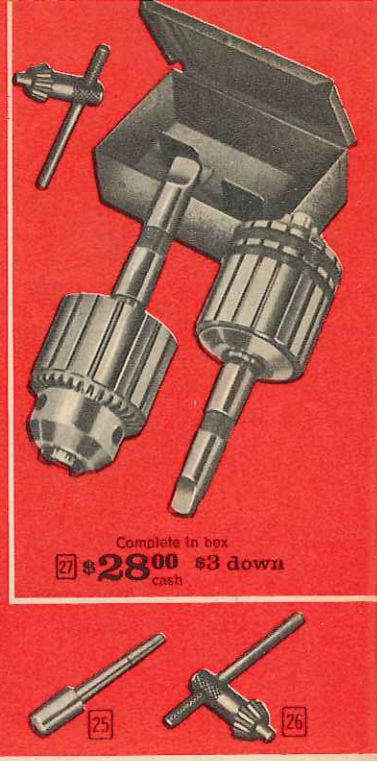
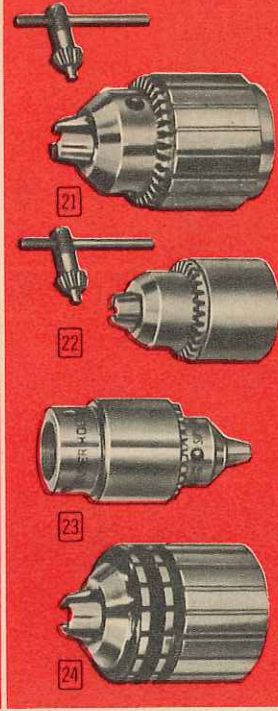
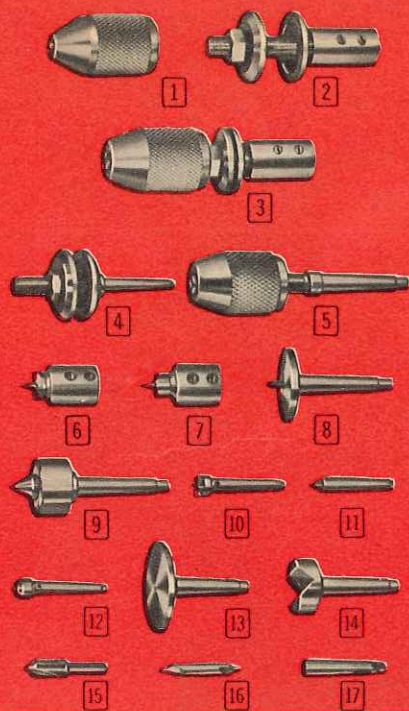

Chucks and Accessories for Drill Presses, Lathes, etc.

- 1** CRAFTSMAN screw-on 3-way Chucks. Tapped to fit 1/2-in. by 20-thread spindles. *Please state size wanted.*
 9 M 2248—1/4-in. capacity. Shipping weight 5 oz. 98c
 9 M 2256—1/2-in. capacity. Shipping weight 14 oz. \$1.39
 9 M 2132—1/2-in. capacity. As above, but for 1/2-inch x 24-thread spindle. Shipping weight 12 oz. \$1.19
- 2** CRAFTSMAN General-purpose Work Arbor. Converts motor into a grinder, polisher, buffer, etc. Carbon steel. 4 3/8 in. long overall. 3 3/8-in. spindle has 1/2-in. x 20-thread. Has steel flanges. Fits straight unthreaded spindle. *State 1/2 or 5/8-in. bore.*
 9 M 2164—Shipping weight 12 ounces. \$1.39
- 3** Arbor with 3-jaw, 1/2-inch Drill Chuck. Chuck and 1/2-in. x 20-thread arbor with steel flanges. Fits unthreaded straight spindle. *State 1/2 or 5/8-in. bore.*
 9 M 2151—Shipping weight 1 lb. 10 oz. \$2.29
- 4** Work Arbors. For mounting drill chucks or holding grinding, buffing wheels, etc. 1/2-in. x 20-thread. Morse taper shank, 2 steel flanges for clamping wheels.
 9 M 2117—No. 0 Morse taper. Shipping weight 8 oz. \$1.39
 9 M 2153—No. 1 Morse taper. Shipping weight 9 oz. 1.49
 9 M 2152—No. 2 Morse taper. Shipping weight 11 oz. 1.49
- 5** Work Arbors with Chucks. 3-jaw, screw-on type chucks. 1/2-in. capacity; tapped 1/2-in. x 20-thread.
 9 M 2276—No. 0 Morse taper, chuck, arbor. Wt. 1 lb. 4 oz. \$2.75
 9 M 2234—No. 1 Morse taper, chuck, arbor. Wt. 1 lb. 8 oz. 2.85
 9 M 2247—No. 2 Morse taper, chuck, arbor. Wt. 1 lb. 8 oz. 2.85
- Lathe Centers.** For any lathe with 5/8-in. straight unthreaded spindle. Replaceable center points.
6 9 M 2105—Headstock Spur Center. Shipping weight 6 ounces. \$1.19
7 9 M 2102—Tailstock Cup Center. Shipping weight 6 ounces. 1.19
- 8** Screw Centers. For facing and hollowing operations. Replaceable center. Morse taper shank.
 9 M 2116—No. 1 Morse taper. Shpg. wt. 12 oz. \$1.79
 9 M 2115—No. 2 Morse taper. Shpg. wt. 14 oz. 1.89
- 9** Ball-bearing 60° Center. For hardwood or metal.
 9 M 2112—No. 1 Morse taper. Shpg. wt. 8 oz. \$3.49
 9 M 2113—No. 2 Morse taper. Shpg. wt. 10 oz. 3.49
- 10** Spur Centers. Use for wood turning.
 9 M 2108—No. 0 Morse taper. Shpg. wt. 3 oz. \$1.19
 9 M 2106—No. 1 Morse taper. Shpg. wt. 4 oz. 1.29
 9 M 2107—No. 2 Morse taper. Shpg. wt. 7 oz. 1.49
- 11** 60° Centers. For turning hardwoods and metals.
 9 M 2103—No. 0 Morse taper. Shpg. wt. 3 oz. 98c
 9 M 2110—No. 1 Morse taper. Shipping wt. 4 oz. 98c
 9 M 2111—No. 2 Morse taper. Shipping wt. 6 oz. \$1.09
- 12** Tailstock Cup Centers. Support work in tailstock.
 9 M 2109—No. 0 Morse taper. Shpg. wt. 3 oz. \$1.19
 9 M 2100—No. 1 Morse taper. Shipping wt. 4 oz. 1.29
 9 M 2101—No. 2 Morse taper. Shipping wt. 7 oz. 1.49
- 13** 9 M 2187—Drill Pad. Use in tailstock as rigid support for drilling flat or square work. Diam. of face, 3 3/8 in. No. 2 Morse taper. Shpg. wt. 1 lb. 2 oz. \$2.29
- 14** 9 M 2114—Crotch Center. Centers round work in tailstock for cross drilling. No. 2 Morse taper. Shpg. wt. 1 lb. \$1.89
- 15** 9 M 6697—82° Center Reamer and Countersink. 3/8-in. size; 1/4-in. shank diameter. Shpg. wt. 2 oz. \$1.49
- 16** 9 M 2060—High Speed Combined Drill and Countersink 1/8-in. 5/16-in. body; or 7/64-in. 1/4-in. body. *State size.* Shipping weight 2 ounces. 98c
- 17** 9 M 2161—Adapter Sleeve. To reduce from No. 2 to No. 1 Morse taper. Shipping wt. 5 oz. \$2.29

- 18** CRAFTSMAN Independent 4-jaw Chucks. Precision made. Body of special alloy steel has deep, wide jaw slots for added strength and greater bearing surface. Four reversible jaws, drop forged from a solid bar of special steel, work independently; especially useful for holding irregularly shaped pieces. Large jaw screw. Acme threaded. T-handle wrench included. These chucks will fit any lathe with spindle diameters and threads per inch listed below.
- | Catalog number | Will fit spindle | Diam. | Shipping weight | Each |
|----------------|------------------------|-------|-----------------|--------|
| 9 M 2137 | 1/2 inch by 24 thread | 3 in. | 2 lbs. 8 oz. | \$9.59 |
| 9 M 2157 | 1/2 inch by 20 thread | 3 in. | 2 lbs. 8 oz. | 9.59 |
| 9 M 2156 | 3/4 inch by 16 thread | 4 in. | 3 lbs. 14 oz. | 11.59 |
| 9 M 21406 | 1 inch by 10 thread | 4 in. | 3 lbs. 12 oz. | 11.59 |
| 9 M 2138 | 1 inch by 8 thread | 4 in. | 3 lbs. 12 oz. | 11.59 |
| 9 M 2139 | 1 1/2 inch by 8 thread | 6 in. | 9 lbs. 10 oz. | 22.50 |
| 9 M 2141K | 1 1/2 inch by 8 thread | 8 in. | 25 lbs. | 35.95 |
- When ordering please be sure to check and see if you have listed the catalog number correctly.*
- 19** CRAFTSMAN Universal 3-jaw Chucks . . . for medium duty. Self-centering, lever operated. Case hardened, cold rolled steel jaws; polished steel body and scroll. Body casting precision threaded; fits directly on spindle. Has outside and inside sets of jaws. Chuck wrench is included with each chuck.
- | Catalog number | Will fit spindle | Diam. | Shipping weight | Each |
|----------------|------------------------|-------|-----------------|---------|
| 9 M 2296 | 1/2 inch by 20 thread | 3 in. | 3 lbs. 5 oz. | \$27.50 |
| 9 M 2297 | 1 inch by 8 thread | 4 in. | 4 lbs. 5 oz. | 32.50 |
| 9 M 2298 | 1 1/2 inch by 8 thread | 5 in. | 10 lbs. | 39.50 |
| 9 M 2299C | 1 1/2 inch by 8 thread | 6 in. | 15 lbs. | 49.50 |
- 20** CRAFTSMAN Universal 3-jaw Fine Quality Lathe Chucks. Heavy duty self-centering type. Jaws are controlled by single screw and pinion gear. Great accuracy, leverage, holding power. Perfect for centering work. Chuck body casting of semi-steel. Alloy metal scroll and alloy steel pinion. Alloy steel jaws are heat treated and hardened, have raised steps. Complete with inside and outside gripping jaws. T-handle chuck wrench is included with each chuck.
- | Catalog number | Will fit spindle | Diam. | Shipping weight | Each |
|----------------|------------------------|-------|-----------------|---------|
| 9 M 21407 | 1 inch by 10 thread | 4 in. | 5 lbs. 3 oz. | \$41.50 |
| 9 M 2163 | 1 inch by 8 thread | 4 in. | 5 lbs. 3 oz. | 41.50 |
| 9 M 2165 | 1 1/2 inch by 8 thread | 5 in. | 8 lbs. 6 oz. | 48.50 |
- 21** Geared, Key-type Headstock Chucks.
 9 M 2044—Capacity 0 to 1 1/2 inch. Fits only 1-in., 8-thread spindle. *Do not use with arbor. Shipped postpaid.* (Shipping weight 3 pounds 10 ounces) \$16.00
 9 M 2763—Capacity 0 to 1 1/2 inch. Fits only 1-in., 10-thread spindle. *Shipped postpaid.* (Shipping weight 2 pounds 2 ounces) \$16.00
 9 M 2144—Capacity 1/4 to 3/4 inch. Fits 1 1/2-in., 8-thread spindle. Can be used with No. 3 Jacobs taper arbor. *Postpaid.* (Shipping weight 3 pounds 12 ounces) \$20.00
 9 M 2121—Capacity 1/16 to 3/4 inch. Will fit 1 1/2-in., 8-thread spindle. *Will not fit any type arbor. Postpaid.* (Shipping weight 5 pounds 8 ounces) \$23.75
- 22** Drill Press Chucks With Keys.
 9 M 2142—Key-type chuck. Fits arbors with No. 33 Jacobs taper. Capacity 3/64 to 1/2 in. Shipping weight 1 pound. \$8.79
 9 M 2143—Key-type chuck. Fits arbors with No. 33 Jacobs taper. Capacity 0 to 1/2 in. Shipping weight 1 pound 11 ounces. \$9.59

- Lock-type Key Chucks**
23 Safer . . . swiveling threaded lock collar screws on spindle . . . keeps chuck firmly seated regardless of thrust. For drill presses with 1 1/16-in. x 20-thread collar and Jacobs No. 33 taper. Steel jaws heat treated. Hardened ground body. With key.
 9 M 2962—Capacity 0 to 1/2 inch. Shpg. wt. 1 lb. 11 oz. \$10.59
 9 M 2963—Capacity 3/64 to 1/2 in. Shpg. wt. 1 lb. 4 oz. 9.79
- Key Chucks for Electric Drills**
 9 M 29783—Capacity 1/4 to 3/4 inch. Fits 3/8-in., 24-thread spindle. Shipping weight 8 oz. \$5.60
 9 M 2979—Capacity 0 to 1/4 inch. Industrial type. Fits 3/8-in., 24-thread spindles. Shipping weight 9 oz. 5.89
 9 M 2147—Capacity 1/16 to 3/8 inch. Fits 3/8-in., 24-thread spindles. Shipping weight 11 oz. 6.29
 9 M 29803—Capacity 3/64 to 1/2 inch. Fits 1/2-in., 20-thread spindles. Shpg. wt. 1 lb. 4 oz. 7.60
 9 M 2136—Capacity 3/64 to 1/2 inch. Fits 3/8-in., 16-thread spindles. Shpg. wt. 1 lb. 5 oz. 7.60
- Center Rest Chuck. Postpaid.**
24 9 M 2991—Capacity 1/4 to 3/4 in. Fits No. 3 Jacobs taper arbor. (Shpg. wt. 3 lbs. 2 oz.) \$14.25
- Chuck Arbors for 9 M 2142, 9 M 2143 (left below)**
25 9 M 2131—No. 0 Morse and No. 33 Jacobs taper. Shipping weight 1 lb. 5 oz. \$1.29
 9 M 2123—No. 1 Morse and No. 33 Jacobs taper. Shipping weight 1 lb. 6 oz. 1.29
 9 M 2124—No. 2 Morse and No. 33 Jacobs taper. Shipping weight 1 lb. 9 oz. 1.29
- For 9 M 2129, 9 M 2144 (below), 9 M 2991 Chucks (above)
 9 M 2133—No. 0 Morse and No. 3 Jacobs taper. Shipping weight 1 lb. 7 oz. \$1.29
 9 M 2154—No. 1 Morse, No. 3 Jacobs taper. Wt. 8 oz. 1.29
 9 M 2126—No. 2 Morse and No. 3 Jacobs taper. Shipping weight 1 lb. 10 oz. 1.29
- 26** Chuck Keys. Fit Jacobs, Supreme or Sears key chucks as listed below. *Order by catalog number.*
- | Catalog number | Jacobs Chuck | Supreme Chuck | Sears Chuck | Shpg. wt. | Price Each |
|----------------|---|--|-------------------------------|-----------|------------|
| 9 M 2051—fits | 1, 1A, 1B, 1BS | 1A, 1T1 | 9 M 29783 | 4 oz. | 39c |
| 9 M 2052—fits | 3, 3A, 3B, 3AE, 6, 6A2A, 6A33, 6B, 6AE, 34, 34B, 34VR, 14N, 54B, 55B, 56B, 58B, 75A, 633C | 6B, 6D, 6T2, 6T33, 6M 2143, 9 M 2962 | | 10 oz. | 59c |
| 9 M 2053—fits | 16N, 18N, 36B, 59B | 9F, 9T3 | | 12 oz. | 89c |
| 9 M 2054—fits | 32, 32B, 33, 33B, 11N, 3333C | 3B, 3D, 3T2, 5B, 5D, 5T33, 5T33C, 5T33C, 15T33, 15T33C | 9 M 2142, 9 M 2963, 9 M 29803 | | 7 oz. 59c |
| 9 M 2073—fits | 7, 7B, 7-1A | 4A, 4B, 4C, 4T1, 4T2 | 9 M 2979, 2976 | | 7 oz. 49c |
| 9 M 2149—fits | 30, 30B | 7A, 7B, 7T1, 7T2, 7T3A | 9 M 2147 | 4 oz. | 59c |
- 27** Commutator Kit. For holding armature shafts. Contains No. 75A armature driving chuck; No. 100 center rest chuck (1/4 to 3/4-in. capacity); two arbors (No. 2 Morse taper, metal end; No. 3 Jacobs taper head end); chuck key, shank box. *Postpaid.*
 9 M 2129—Shipping weight 7 lbs. 4 oz. \$28.00

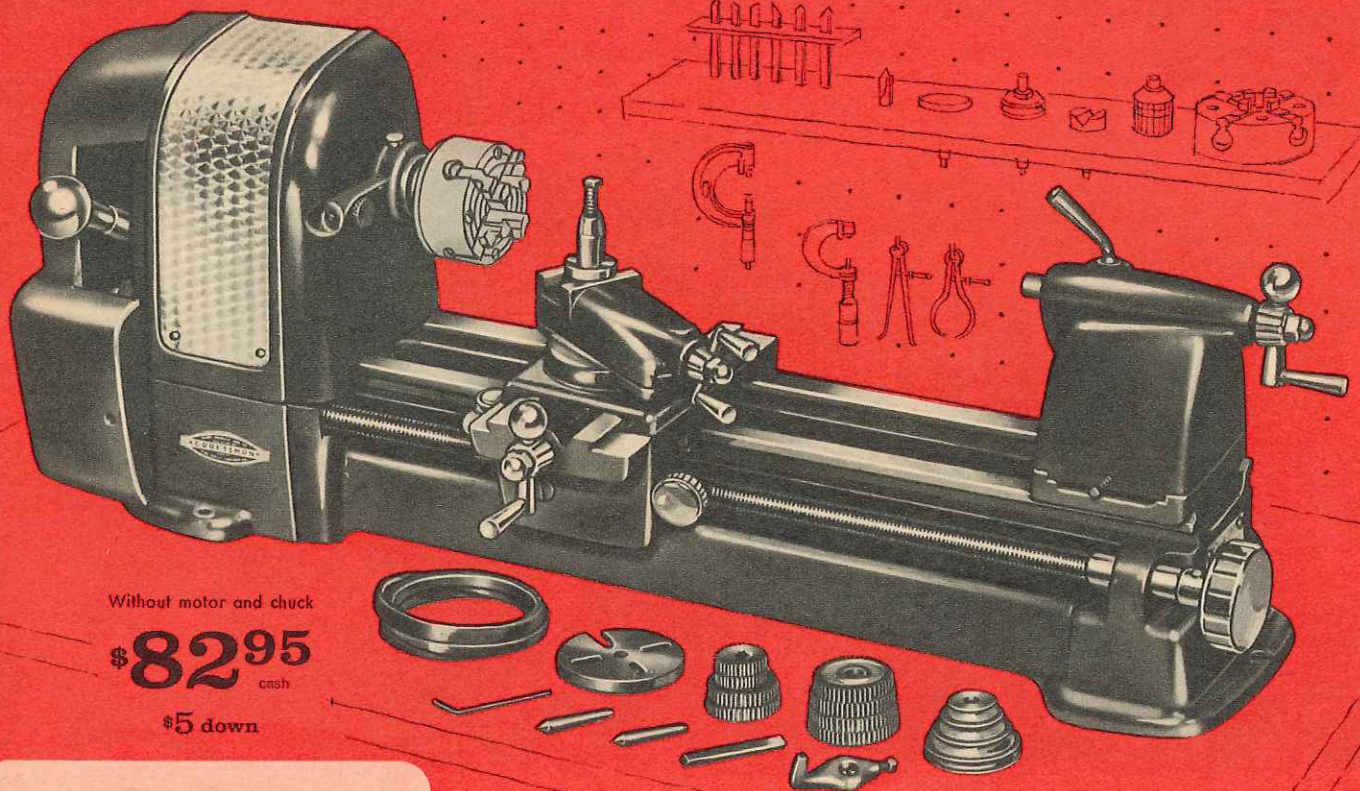

Without motor and chuck
\$82⁹⁵
 cash
 \$5 down

SPECIFICATIONS

- Swing over bed 6 inches
- Distance between centers 12 $\frac{1}{8}$ inches
- Spindle: Nose size $\frac{1}{2}$ -in. x 20-thread
Taper No. 0 Morse
Bore $\frac{1}{4}$ inch
- Bearings 2 porous bronze
- Thread range 8 to 96—right or left hand
- Feeds0024, .0039, .0048, .0078
- Back gear ratio5 to 1
- Compound rest travel 1 $\frac{3}{4}$ inches
- Cross slide travel 2 $\frac{1}{4}$ inches
- Tailstock ram travel 1 $\frac{1}{4}$ inches
- Tailstock set over $\frac{1}{4}$ inch
- Motor recommended
(minimum) $\frac{1}{2}$ -HP 1725 RPM
- Machine pulley (included) 3-step "V" type
- Motor pulley (included) 3-step "V" type
- Speeds Six: 120 to 1325 RPM
- Mounting dimensions 21 $\frac{7}{16}$ x5 $\frac{5}{16}$ inches
- Overall dimensions 10 $\frac{1}{4}$ x9 $\frac{1}{2}$ x26 $\frac{3}{4}$ inches

CRAFTSMAN 6-in. Metal-turning Lathe

REG. U. S. PAT. OFF.

The only back-geared screw-cutting lathe in this price range
 Offset-center design for extra smoothness and accuracy

We believe there's no other metal-turning lathe like it! Much smoother and more accurate than is ordinarily possible with a lathe of this size. Designed for precision work such as turning armatures, model making, experimental work, tool room work, and scores of other small jobs.

Back gears give slow speeds and greater power needed to machine a variety of metals. Speed range permits wood and plastic turning also.

Offset center construction overcomes the disadvantage of most small lathes . . . keeps pressure of work on tool bit between the ways . . . gives better support to compound . . . makes it possible to handle larger work. Centers are offset $\frac{9}{16}$ inch back of bed center line.

Smooth-adjusting compound swivel operates on precision-machined V-way bed. Spring tension on threaded dial assembly gives positive contact.

End play is eliminated! Compound rest and cross-feed are accurately gibbed for wear take-up. Headstock has double bearings of porous bronze; adjustable front bearing. Hardened, ground steel spindle threaded $\frac{1}{2}$ -inch x 20-thread. Forward and reverse lever-locking plunger; spring operated. Removable No. 0 Morse taper centers. Tailstock may be set over for turning tapers.

Complete with accessories shown above, including two 60-degree centers, $\frac{1}{4}$ -inch tool bit, Allen wrench, $\frac{1}{2}$ -inch lathe dog, 4-inch face plate, 8 threading gears, motor pulley, machine pulley, and $\frac{3}{4}$ x36-inch V-belt. (See other accessories listed below).

Motor not included. We recommend using at least a $\frac{1}{2}$ -HP 1725 RPM motor (see page 64 for motors). Shipping weight 61 pounds.

99 M 2127L—Without motor and chuck \$82.95

High-quality Accessories designed to increase the usefulness of the above lathe

The following accessories fit above lathe

See opposite page for listings and prices

- 9 M 2296—3-jaw Lathe Chuck; $\frac{1}{2}$ x20-thread; for holding work.
- 9 M 2157—4-jaw Lathe Chuck; $\frac{1}{2}$ x20-thread; for holding work.
- 9 M 2117—Work Arbor with collars; 0 Morse taper; for mounting grinding and wire wheels.
- 9 M 2276—Work Arbor with chuck; 0 Morse taper; for use with drills, reamers, etc.
- 9 M 2109—Cup Center; 0 Morse taper; supports work in tailstock.
- 9 M 2108—Spur Center; 0 Morse taper; use for wood turning.
- 9 M 2103—60-degree center; 0 Morse taper. Use in tailstock for centering.
- 9 M 2131—Chuck Arbor; 0 Morse and 33 Jacobs taper; for holding 9 M 2142 and 9 M 2143 Drill Chucks.
- 9 M 2142—Drill Chuck; 33 Jacobs taper; holds $\frac{5}{64}$ to $\frac{1}{2}$ -inch drills.
- 9 M 2143—Drill Chuck; 33 Jacobs taper; holds 0 to $\frac{1}{2}$ -inch drills.
- 9 M 2133—Arbor for center rest chuck; 0 Morse and 3 Jacobs taper; for use with chuck below.
- 9 M 2991—Center-Rest Chuck; 3 Jacobs taper; for centerless armature machining. Use with Arbor 9 M 2133 above.
- 9 M 2144—Headstock Chuck; use with 9 M 2133 Arbor above.
- 9 M 2129—Commutator Kit; requires two Arbors (9 M 2133) to fit above lathe.



6-piece Formed Tool Bit Set. Professional quality in every detail. $\frac{1}{4}$ -inch size. Set includes the following—threading bit; left-hand and right-hand facing bits; left-hand and right-hand and round-nose turning bits. For high or low-speed operation. Shipping weight 5 ounces.
 9 M 2205 \$2.69

4-piece Tool Post Set. Includes the following— $\frac{1}{4}$ and $\frac{3}{16}$ -inch boring tools; $\frac{1}{4}$ -inch threading tool; and stiffening block. Tools set on rocker in tool post with stiffening block over top. Professional quality, 1-piece construction. Shipping weight 4 ounces.
 9 M 2008 \$5.97

Metal Lathe Manual. Complete, up-to-date manual with practical explanation of metal lathe operations. 258 pages, including pages of easy-to-follow machinists' tables. Fully illustrated. Has convenient index tabs. Shipping weight 1 pound 4 ounces.
 9 M 2925 \$2.50

With orders of \$20 or more, buy on Sears Easy Terms.

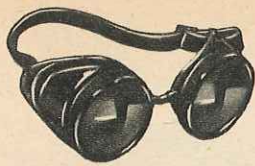

Weldor's Goggles

Protection you can't afford to be without. Meet U.S. Bureau of Standards requirements for shade and absorption of ultra-violet, infra-red rays. The higher the "shade" number (4, 5, 6, 10) the darker the lens.

9M1862—For arc welding. Shade 10 lenses. Shpg. wt. 5 oz. \$2.98
 9M1863—For light oxy-acetylene welding, burning. With elastic band, shade 5 lenses. Wt. 4 oz. . . \$2.98

Over-eyeglasses style Goggles. Like above, but fit comfortably over regular prescription eyeglasses.

9M1864—Wt. 12 oz. . . \$2.98

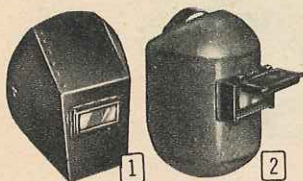

Industrial Welding Helmets

Made of vulcanized shock-proof fiber. Adjust to size. Throw back without removing.

1 Fabricated. Stop joints for welding or "up" position. Glass holder. With cover glass. No. 10 filter plate. Shpg. wt. 2 lbs. 8 oz. 9M1326. \$4.39

2 Fiber glass. Our Best. 1-piece, smooth, molded surface. Easy "on-off" tension and head size adjustment. Slide-in lens holder. Adjustable chin rest. With cover glass. State No. 10 or 12 filter plate. Shipping wt. 2 lbs. 14 oz. 9M13225. \$11.49

Extra Filter Plates, Cover Glass. For arc welding; fit most helmets. 2x4 1/2 in.

9M1327—No. 10 shade. For 75 to 250 amp. welding. Shpg. wt. 5 oz. \$1.00

9M1328—No. 12 shade. For 250 amp. or greater welding. Shpg. wt. 5 oz. \$1.00

9M1329—Clear Cover Glass. Shpg. wt. 5 oz. 9c

If you can follow a straight line you can weld

GUARANTEE

If any CRAFTSMAN Arc Welder shows defects in materials or workmanship, we will repair or replace it free if returned within one year of the date of purchase. SEARS, ROEBUCK AND CO.



90-amp. for Hobbyists Operates on any 30-amp. fused line

\$9750 cash **\$5** down

3 One of the easiest welders we know of to use. Ideal for repairing farm equipment, auto and truck bodies, etc. . . just right for making wrought iron furniture and "do-it-yourself" projects.

Can be used any place there's a 30-amp. fused line . . . on either 115 or 230-volt lines. See welder specifications in table below.

Includes: 2 flexible work cables (7-ft. ground and 9-ft. electrode), electrode holder, wire brush, contact rods, standard rods, 3-prong receptacle, helmet and manual. UL approved. 12 1/2 x 10 1/4 x 14 1/4 inch 18-gauge steel cabinet. On-off switch. Check voltage, phase, cycle and capacity of your line before ordering.

99M2030N—Shipping weight 72 pounds. \$97.50

"Arc-Weld-it-Yourself" Manual. 165 illustrations. 9M2025—36 pages. Shpg. wt. 3 oz. 69c

Large Capacity Industrial Models Designed for jobs requiring high welding heats

200-amp. model **\$23250** cash **\$10** down
 295-amp. model **\$24995** cash **\$10** down

4 Here are the CRAFTSMAN welders you'll need and want for those really tough jobs—jobs that smaller capacity machines can't handle. They're perfect for repair, factories and maintenance shops . . . operate at 30 arc volts.

Fan cools and cleans double-insulated coils for increased efficiency, longer life. Large rear wheels, detachable handle provide portability. Built-in reactance increases open circuit voltage on all heats. 19 1/2 x 18 1/4 x 28 1/4 inch cabinet; on-off switch. Each model includes assorted electrodes, electrode holder, wire brush, 18-ft. electrode and 12-ft. ground cables, helmet and manual. Check voltage, cycle, phase and capacity of your line with power company.

200-amp. continuous duty model. Can be used with rods up to 3/16 in. in diameter. Meets Underwriters' Laboratories, Inc. specifications for industrial welding. See welder specifications in table below. 99M2012N—Shpg. wt. 210 lbs. \$232.50

295-amp. intermittent duty model. Our highest capacity arc welder. Has 75% power factor for lower operating cost. Can be used with rods up to 1/4-inch in diameter. See specifications in table below. 99M2015N—Shpg. wt. 230 lbs. . . \$249.95

Catalog Number	Primary volts	AC single phase (cycles)	Ampers max. input	Primary max. amps. short circuit	Number of heats	Rod sizes	Max. KVA	Max. KW	Fuses (fusetrone or fustal)	Maximum open circuit secondary	Duty cycle	Power factor
99M2012N	230	50-60	53	78	16 (20-200)	1/16 to 3/16 in.	12.2	8.7	60 amps.	.80 volts.	(*)	75%
99M2015N	230	50-60	75	75	24 (50-295)	3/32 to 1/4 in.	17.3	12.8	70 amps.	.80 volts.	20%	75%
99M2024N	230	50-60	37	62	16 (20-180)	1/16 to 3/16 in. (3/32-in. contact)	8.50	6.9	40 amps.	.80 volts.	20%	75%
99M2023N	230	50-60	37	60	6 (60-180)	3/32 to 3/16 in. (3/32-in. contact)	8.50	7.3	40 amps.	.78 volts.	20%	78%
99M2030N	115-230	50-60	30-15	45	6 (40-90)	1/16 to 3/32 in. (3/32-in. contact)	3.5	2.5	30-15 amps.	.65 volts.	20%	78%

*30% at 200 amps.; 50% at 160 amps. †50% at 180 amps.



5 CRAFTSMAN Twin Carbon Torch. Industrial type. Increases utility of your welder. Braze, solder, heat, etc. on AC arc welders. Large insulated fiber grip; quick-sliding control. Switch. Lightweight. 15 1/2 in. long. 5-ft. cables. 9M2007—Shpg. wt. 4 lbs. 6 oz. . . . \$14.49

Cored Carbons for above. Order by correct catalog number.
 9M2020—1/4 x 6 inches long. Shipping weight 6 oz. . . . Pkg. of 10 for \$1.49
 9M2021—5/16 x 6 inches long. Shipping weight 6 oz. . . . Pkg. of 8 for 1.49
 9M2022—3/8 x 6 inches long. Shipping weight 7 oz. . . . Pkg. of 6 for 1.49

6 Combination Wire Brush and Chipping Hammer. Forged chipping head. 12 inches long overall. 9M2074—Shipping weight 1 pound 2 ounces. . . . \$3.69
 9M2081—Replacement Brush for 9M2074. Wt. 6 oz. . . . 65c

Extension Cables. For all our welders except 99M2030N, 99M2099N. 25-ft. rubber-covered No. 2 cable. 9M2069—For Ground. Shpg. wt. 9 lbs. . . . \$13.98
 9M2070—For Electrode. Shpg. wt. 9 lbs. . . . 13.98

7 Rod Holder. 200-amp. capacity. Copper-alloy conductors. Molded asbestos jaw covers. Adjustable spring tension for positive grip on all sizes of electrodes up to 1/4 in. 9M2071—7 3/4 in. overall length. Shpg. wt. 12 oz. . . . \$4.29

8 Ground Clamp. Copper alloy. For current up to 200 amperes. High electrical conductivity. 9M2076—Shipping weight 12 ounces. . . . \$2.29

9 Professional Electrode Assortment. 11 sizes and types, including contact, mild steel, cast iron, and hard-surfacing rods. 99M2047K—25-lb. pkg., welding book. Shpg. wt. 26 lbs. . . . \$10.98

Hobbyist Electrode Assortment. 5 lbs. of coated rods . . (general-purpose, hard-surfacing, nicol, and self-starting contact rods). 9M2049—With welding book. Shipping weight 5 lbs. 8 oz. . . . \$3.98

10 CRAFTSMAN Aluminum Brazing and Soldering Kit. Use with arc welder or propane torch. Includes No. 716 aluminum brazing wire; No. 803 aluminum soldering wire; aluminum soldering and brazing fluxes. 9M2039—Brushes, welding book. Shpg. wt. 8 oz. . . . \$2.39

11 CRAFTSMAN No. 1 All-purpose Brazing Flux. Use with brazing rods when brazing steel, iron. Also when welding copper, brass, bronze. With welding book. 9M2056—4-ounce can. Shipping weight 8 ounces. . . . 49c

with CRAFTSMAN Arc Welders and Contact-Rods

REG. U. S. PAT. OFF.

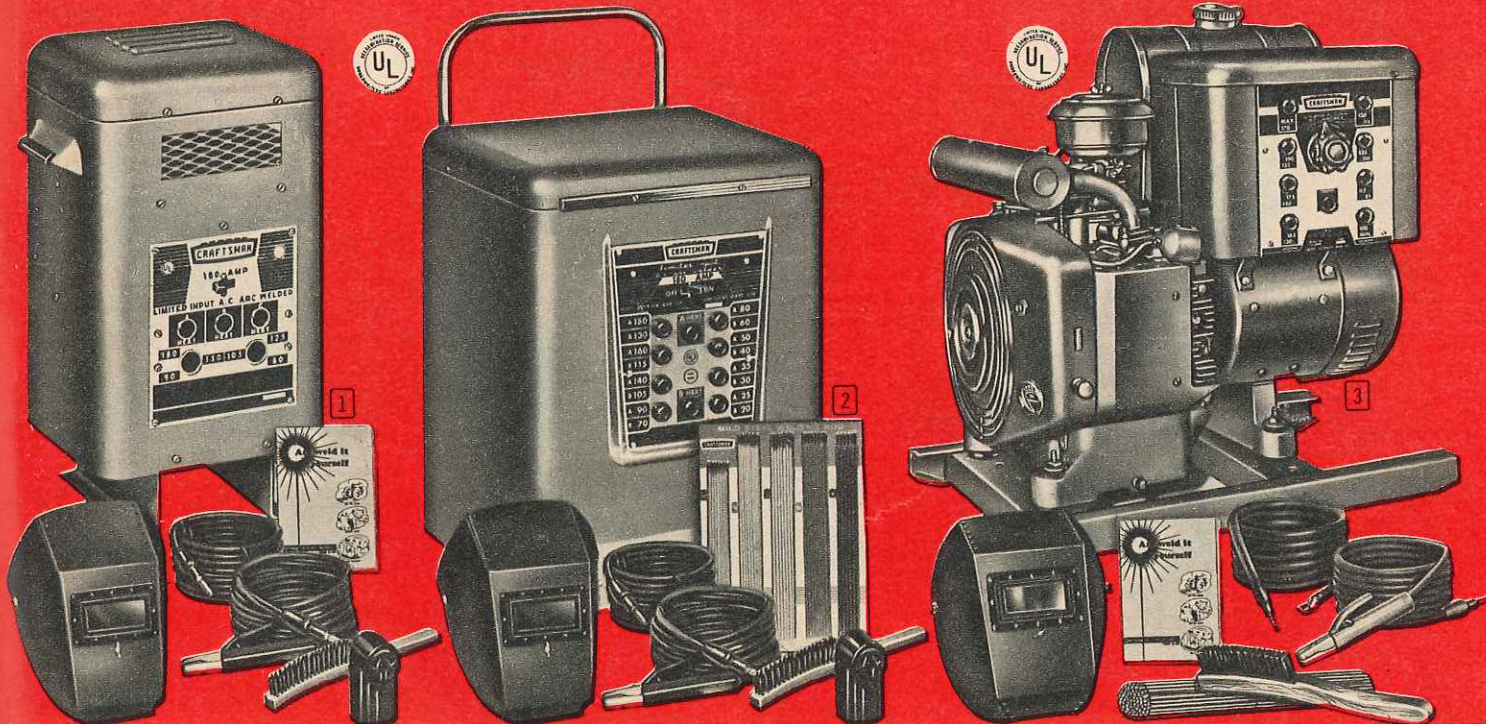

180-amp. Models . . ideal for farm work
Can be operated on REA and other rural power lines

\$139⁹⁵ \$5 down
cash

1 Here's an intermittent duty welder that's ideal for making on-the-spot repairs. Its light weight (only 68 pounds), small compact size (21 $\frac{1}{2}$ x11 $\frac{3}{4}$ x10 inches) and 2 grip handles make it easy to move around from job to job. 6 popular heats let you cut, weld, braze and solder.

Coils and transformers are insulated to reduce electrical breakdowns. Fan cooled coils, helps keep dirt off them to improve efficiency. *UL approved and N.E.M.A. rated.* On-off switch. Includes 18-ft. electrode cable and holder, 12-ft. ground cable, helmet, wire brush, receptacle and instruction manual.

See welder specifications in the table on the opposite page.

99 M 2023N—Shipping weight 86 lbs..\$139.95

\$169⁹⁵ \$5 down
cash

2 Cuts, brazes, solders and welds metals of all thicknesses. For intermittent duty where local distribution transformer is 3 KVA or greater. Requires 40-amp. line. Fan-cooled coils and transformers dipped and baked in insulating varnish. Built-in reactance automatically increases open-circuit voltage on all heats. On-off switch. *UL approved; N.E.M.A. rated.*

Copper wire, double insulated with glass. Steel cabinet, 18 $\frac{1}{2}$ x19 $\frac{1}{2}$ x28 $\frac{1}{2}$ in. Two cables (18-ft. electrode, 12-ft. ground), 10-ft. primary cable, plug, receptacle. *Specifications in table on opposite page.* With electrodes, electrode holder, wire brush, helmet, manual. Check voltage, phase, cycle and capacity for your area before ordering.

99 M 2024N—Shpg. wt. 195 lbs.....\$169.95

200-amp. DC Gasoline-engine Arc Welder
Operates anywhere . . doubles as a power source

Without accessories **\$699⁹⁵** \$10 down
cash

3 Versatile power, dependable performance, rugged service—you get all three with this heavy duty welder. Powerful 13-HP (2-cylinder, 4-cycle, air-cooled) Onan engine drives direct-coupled generator to furnish current for welding, cutting, brazing or soldering. Generator also provides 1500-watt, 115-volt, 60-cycle AC for electric drills, grinders and other power tools . . "stand by" household power in event Hi-line power fails.

Sturdy welded steel skid makes transporting easier . . permits you to operate unit from bed of pickup truck. Compact, too . . only 32 inches high, 19 $\frac{1}{2}$ inches wide, 30 inches long. Industrial capacity 5-gallon tank gives you a longer running period without having to waste time refilling.

Variable shunt field rheostat for voltage control. 8 heat taps with overlapping ranges. 70 to 200-amperes actual welding current. 30 arc volts; 50% duty cycle. Use rods up to $\frac{3}{16}$ inch in diameter. Two convenient outlet receptacles, instruction manual included. Accessories not included; see DC Welder Kit listed below. Shipped by freight (rail or truck) or express from factory in St. Louis, Missouri. Just \$10 down, \$33.50 monthly on Sears Special Easy Terms . . see inside back cover for details.

F99 M 2099N—Shipping weight 420 pounds.....Cash \$699.95

CRAFTSMAN Cutting Rods. For cutting steel and iron. Use with 150-ampere or larger welders. AC-DC (straight polarity). Shpg. wt. 1 lb. 3 oz. per package.

9 M 2028— $\frac{5}{32}$ x12 inches, 1-pound package 85c
9 M 20282— $\frac{1}{8}$ x14 inches, 1-pound package 75c

CRAFTSMAN Mild Steel Rods. For AC-DC (reversible polarity). With welding book.

Diam. x length	Size pkg.	Catalog No.	Shpg. wt.	Package
$\frac{5}{64}$ x12 inches.	. . 5 lbs.	. . 9 M 20010.	. . 6 lbs.	. . \$2.98
$\frac{3}{32}$ x12 inches.	. . 5 lbs.	. . 9 M 20017.	. . 6 lbs.	. . 2.49
$\frac{1}{8}$ x14 inches.	. . 10 lbs.	. . 9 M 20031.	. . 11 lbs.	. . 3.79
$\frac{5}{32}$ x14 inches.	. . 10 lbs.	. . 9 M 20036.	. . 11 lbs.	. . 3.69
$\frac{3}{16}$ x14 inches.	. . 10 lbs.	. . 9 M 20038.	. . 11 lbs.	. . 3.59

Cast-iron Rods, AC-DC (reverse polarity).

Diam. x length	Size pkg.	Catalog No.	Shpg. wt.	Package
Machineable type				
$\frac{3}{32}$ x13 $\frac{1}{2}$ inches.	. . 1 lb.	. . 9 M 2027.	. . 1 lb. 3 oz.	. . \$3.29
$\frac{1}{8}$ x13 $\frac{1}{2}$ inches.	. . 1 lb.	. . 9 M 20272.	. . 1 lb. 3 oz.	. . 3.19

Non-machineable type

$\frac{3}{32}$ x12 inches.	. . 5 lbs.	. . 9 M 20550.	. . 6 pounds.	. . 3.09
$\frac{1}{8}$ x14 inches.	. . 5 lbs.	. . 9 M 20555.	. . 6 pounds.	. . 2.39

Hard Surfacing Rods, AC-DC (either polarity).

Diam. x length	Size pkg.	Catalog No.	Shpg. wt.	Package
$\frac{3}{32}$ x12 inches.	. . 5 lbs.	. . 9 M 20040.	. . 6 lbs.	. . \$4.29
$\frac{1}{8}$ x14 inches.	. . 5 lbs.	. . 9 M 20043.	. . 6 lbs.	. . 4.19
$\frac{3}{32}$ x14 inches.	. . 5 lbs.	. . 9 M 20046.	. . 6 lbs.	. . 4.09

Special Farm-pack Assortment. Specially picked electrodes for use on tractors, cultivators and other farm equipment. Includes book of welding instructions. 25 pounds of electrodes in assortment.
99 M 20472K—Shipping weight 26 pounds.....\$9.95

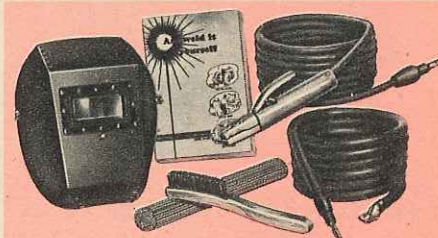

DC Welder Kit

\$25⁹⁵
cash
\$3 down

Complete Welding Kit for DC Gasoline Engine Arc Welder (F99 M 2099N) above.

Includes one each of the following: heavy duty 18-foot electrode cable and 12-foot ground cable; completely insulated electrode holder; industrial welding helmet; wire brush; "Arc-Weld-it-Yourself" instruction manual and a supply of assorted welding electrodes. Shipped from factory in St. Louis, Missouri. Allow postage from your Mail Order house.
F99 M 20995—Shpg. wt. 15 lbs. \$25.95



CRAFTSMAN Mild Steel Contact-type Welding Rods. Simply touch tip to work, draw it along joint. Special powdered-iron coating forms shell around wire core, automatically maintains proper burning speed and arc distance even though outside shell is in contact with work. Comes with welding book.

With self-starting tips. Conductive match heads ignite by current; restart at any point. Meet American Welding Society Specification 6024.

9 M 20640— $\frac{5}{64}$ x9 in. 5-lb. pkg. Shpg. wt. 5 lbs. 10 oz. \$3.59
9 M 20646— $\frac{3}{32}$ x9 in. 5-lb. pkg. Shpg. wt. 5 lbs. 10 oz. 3.59

Without self-starting tips. Strike rod to work to create arc. For AC-DC (reverse polarity). Meet American Welding Society Specification 6024. Order from table below.

Diam. x length	Size pkg.	Catalog No.	Shpg. wt.	Package
$\frac{5}{64}$ x12 in. 10 lbs.	. . 9 M 20290.	. . 11 lbs.	. . \$6.98
$\frac{3}{32}$ x14 in. 10 lbs.	. . 9 M 20293.	. . 11 lbs.	. . 6.29
$\frac{1}{8}$ x14 in. 10 lbs.	. . 9 M 20296.	. . 11 lbs.	. . 3.89
$\frac{5}{32}$ x14 in. 10 lbs.	. . 9 M 20298.	. . 11 lbs.	. . 3.79

Low Hydrogen Rods. Designed for best results when welding high carbon steel or rusty steel. Requires 80 open circuit volts. Shipping weight 11 pounds for each 10-pound package.

9 M 20023— $\frac{1}{8}$ x14 inches, 10-lb. package \$3.98
9 M 20024— $\frac{3}{32}$ x12 inches, 10-lb. package 3.89

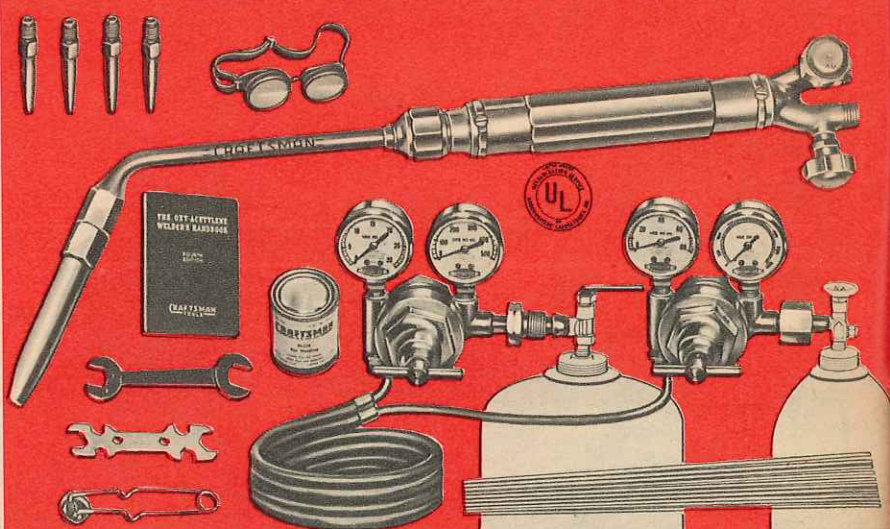
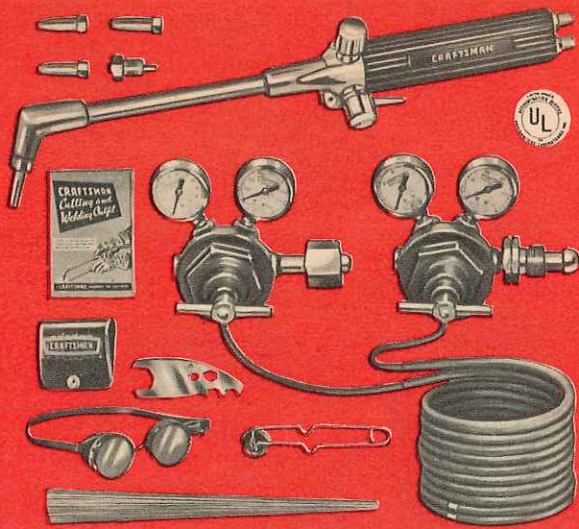

CRAFTSMAN Cutting and Welding Outfit

REG. U.S. PAT. OFF.

Cut and weld with the same torch . . . just change tips! **\$69.50** cash **\$7 down**

Cost-saving versatility . . . here's a single-stage outfit that's designed to do *most any* type of cutting and welding within its capacity. Cuts up to 2 in.; weld up to 1/4 in. with extra tips. No soldered or brazed joints between handle and torch head. Interchangeable cutting and welding tips swaged from copper. Valve knobs control flame adjustment. Trigger-type lever for cutting. Parts in contact with gases are brass, bronze or Monel metal. Safety release oxygen and acetylene valves. *UL approved.* Includes: torch; oxygen and acetylene regulators; 3 welding tips †(W1 to W3); 1 cutting tip ††(K2); tip box; 12 1/2 ft. of 3/16-in. "Siameez" hose; 50-mm professional goggles; assorted welding rods; spark lighter; wrench and instructions. *Not for LP-gas.**

99 M 5515C—Complete outfit. Shipping weight 15 pounds. \$69.50

9 M 5511—Extra Welding Tips for Outfit above. For oxy-acetylene only. Each \$1.19

Sizes: W-1, W-2, W-3, W-4. Shipping weight 10 ounces.

† Welds metal. Up to 3/64 inch. to 3/32 inch. to 1/8 inch. 1/8 to 1/4 inch

9 M 5512—Cutting Tips for Outfit above. For oxy-acetylene only. Sizes K-1, K-2, K-3. Each \$3.79

With 4 pre-heat flames. Shipping weight 7 ounces.

†† Cuts metal. Up to 3/8 inch. 3/8 to 1 inch. 1 to 2 inch

9 M 5517—CRAFTSMAN 3/16-in. Siameez Welding Hose. 12 1/2 feet long. For Cutting and Welding Outfit 99 M 5515C only. Shpg. wt. 2 lbs. 12 oz. \$5.98

CRAFTSMAN Single-stage Welding Outfit

REG. U.S. PAT. OFF.

Balanced pressure non-flash mixer adds extra safety **\$84.95** cash **\$8.50 down**

Built with quality features of the welder on facing page, but is a single-stage outfit. For LP-gas* or acetylene and oxygen. Double "O" ring seat construction for leak-free connection of gooseneck to torch . . . no wrench needed; tighten with hand. Forged bronze-bodied regulators, each has two pressure gauges with brass cases—oxygen and acetylene regulators have patented safety relief mechanism.

Includes: 5 wide-range welding tips (AA-1, AA-2, AA-3, AA-4, AA-5) of one-piece swaged solid drawn copper; won't flash back. 25-ft. length of 3/4-in. heavy-duty twin "Siameez" hose; assorted welding rods, 1-lb. universal flux; 50-mm professional goggles; 2 wrenches; spark lighter; 271-page illustrated Welder's Handbook.

Outfit may be used for cutting with Cutting Attachment 9M5477 and 9M5447 or 9M5467 Cutting Tips (for acetylene) or 9M5478 cutting tips (for LP-gas*) below. Cutting attachment and cutting tips not included with outfit. *UL approved.*

99 M 5476K—Complete outfit. Shipping weight 27 pounds. \$84.95

9 M 5410—One-lb. can Flux. For gas welding of all metals. Shpg. wt. 1 lb. 8 oz. 89c

Tank Adapter for Acetylene Regulators.

9 M 5413—For use with standard size acetylene cylinders having right hand male outlet threads. Shipping weight 12 ounces. \$1.98

9 M 5414—For use with small Prest-O-Lite "B" cylinders having right hand male outlet threads. Shipping weight 12 ounces. 1.98

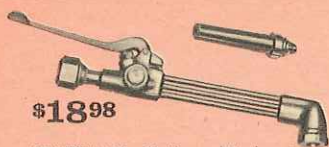

\$18.98

CRAFTSMAN Cutting Attachment. Cuts steel to 6 in. thick with acetylene or LP-gas* and proper tips. Use with 99M5422K (facing page); 99M5476K (above right) or 9M5474 (right). 3-tube construction. *UL approved.* Leak-free attachment. With B-3 (acetylene) tip, instructions. For LP-gas* cutting tips see 9M5478 (right).

9 M 5477—Wt. 3 lbs. 8 oz. \$18.98

Similar to above but fits only our model 624.54290 Torch. B-3 (acetylene) tip and instructions. From Chicago, Ill. factory.

F9 M 5444—Shpg. wt. 3 lbs. \$18.98



\$10.59

CRAFTSMAN Heating-Brazing Set. For Prest-O-Lite type acetylene gas. Use "B" type acetylene cylinder (not included). Requires pressure up to 4 lbs. for largest tip. Needs no oxygen or compressed air. With handle, 3 heating tips, soldering copper, paint burning tip, tank connection, tip cleaner, 5-ft. hose, instructions.

9 M 5446—Wt. 1 lb. 14 oz. \$10.59

*The term LP-gas refers to bottled propane, butane or mixtures thereof.

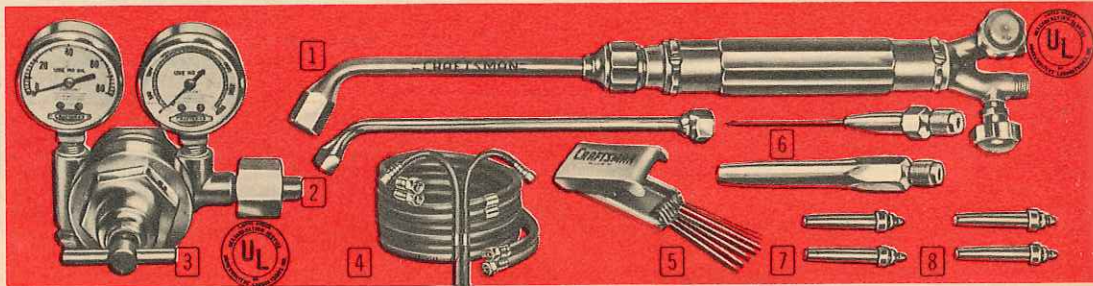

CRAFTSMAN precision-made Accessories

1 CRAFTSMAN Welding Torch. Same as in Welding Outfit 99M5476K above. Use either right or left hand; turns off without disturbing setting of regulators. Easy-gripping fluted handle withstands hard knocks. Forged naval bronze 6-in. gooseneck; will not bend. For welding, use oxy-acetylene only. Can be used with acetylene or LP-gas* for brazing, soldering, heating, bending, etc. Cuts steel with cutting attachment 9M5477 at left, 17 in. long. *UL approved.*

9 M 5474—Shipping weight 3 pounds 2 ounces. \$16.49

2 CRAFTSMAN 12-in. Mixing Chamber. Solid forged bronze. Gooseneck type. Replaces gooseneck of 99M5422K (facing page); 99M5476K or 9M5474 (above) when using AA-7, AA-8 tip.

9 M 5488—Shipping weight 1 pound 10 ounces. \$8.49

3 Oxygen Regulator. 0 to 80 and 0 to 4000-lb. gauges; brass cases. 9M5430—Patented safety release. *UL approved.* Shpg. wt. 5 lbs. 10 oz. \$22.50

High pressure Oxygen Regulator, 0 to 300 and 0 to 4000-pound gauges. Delivery pressure adjustable, 0 to 150 pounds. Must be used when cutting steel over 3 inches thick. *UL approved.*

9 M 5448—Shipping weight 6 pounds 2 ounces. \$22.50

Acetylene Regulator, 0 to 30 and 0 to 500-lb. gauges; brass cases. 9 M 5431—*UL approved.* Shipping weight 5 pounds 10 ounces. \$22.50

4 CRAFTSMAN "Siameez" Welding Hose. 1/4-inch inside diameter. Heavy-duty oxygen hose and acetylene hose vulcanized together to form one unit . . . easier to handle than separate lines. Light, strong, flexible. Smooth lining insures maximum gas delivery. Tightly braided rayon cord reinforcement gives high safety factor. Tough, smooth outside cover resists flame, heat, oil, grease, abrasion. Brass couplings. Also for use with LP-gas*.

9 M 5427—25-foot length. Shipping weight 7 pounds. \$10.49

5 CRAFTSMAN Tip Cleaners. Metal case. Shipping weight 3 ounces. 9 M 5425—For all CRAFTSMAN welding tips. \$1.79

9 M 5445—For all CRAFTSMAN cutting tips. 1.79

CRAFTSMAN Welding and Cutting Tips

6 Welding Tips. Heavy one-piece, swaged, solid-drawn copper. Polished bore. For welding use oxy-acetylene only. For brazing, soldering, heating, bending, etc. use oxy-acetylene or LP-gas*.

Size	Capacity, in.	Size	Capacity, in.	Size	Capacity, in.
AA-0	.. Soldering ..	AA-3	.. 1/8 to 3/16 ..	AA-6	.. 1/2 to 3/4 ..
AA-1	.. 1/64 to 1/16 ..	AA-4	.. 3/16 to 1/8 ..	AA-7	.. 5/8 to 1 ..
AA-2	.. 1/64 to 1/8 ..	AA-5	.. 3/8 to 1/2 ..	AA-8	.. 1 in. and up ..

9 M 5441—State size wanted. Shpg. wt. each 6 oz. \$1.98

7 Cutting Tips. For oxy-acetylene only. Use with any CRAFTSMAN cutting attachment. One-piece, swaged, solid-drawn copper. Has 4 pre-heat flames.

Size	Cuts steel	Size	Cuts steel	Size	Cuts steel
B-1	.. up to 1/8 in.	B-3	.. 1/2 to 1 1/2 in.	B-5	.. 4 to 6 in.
B-2	.. 1/8 to 1/2 in.	B-4	.. 1 1/2 to 4 in.		

9 M 5447—State size wanted. Shpg. wt. each 6 oz. \$4.19

Oxy-Acetylene Cutting Tips. As above, but with 6 pre-heat flames for better pre-heat distribution.

Size of Tip	Cuts Steel	Size of Tip	Cuts Steel
BB2	.. 1/8 to 1/2 inches.	BB4	.. 1 1/2 to 4 inches
BB3	.. 1/2 to 1 1/2 inches.	BB5	.. 3/2 to 6 inches

9 M 5467—State size wanted. Shipping weight 6 oz. \$4.39

8 Cutting Tips For Oxy-LP-gas* only. Two-piece for easy cleaning. Use with any CRAFTSMAN cutting attachment. Instructions included.

Size	Cuts Steel	Size	Cuts Steel	Size	Cuts Steel
BL-1	up to 1/8 in.	BL-3	1/2 to 1 1/2 in.	BL-5	4 to 6 in.
BL-2	1/8 to 1/2 in.	BL-4	1 1/2 to 4 in.		

9 M 5478—State size wanted. Shipping wt. each 7 oz. \$4.19

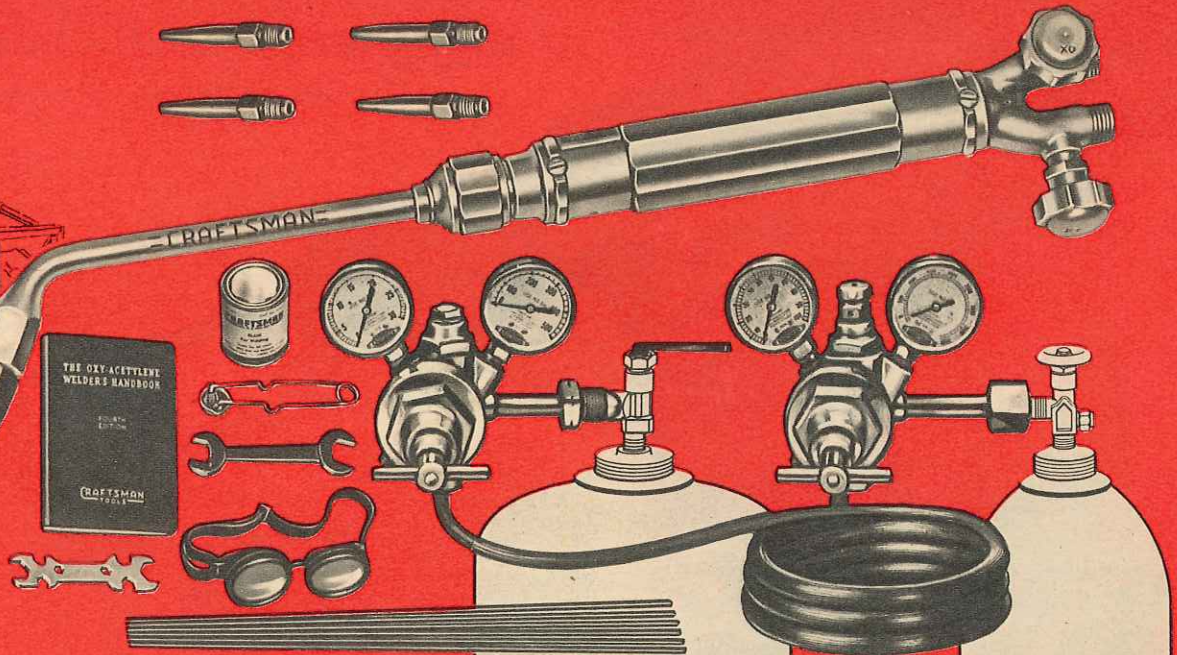

CRAFTSMAN Heavy-duty 2-stage Welding Outfit

REG. U. S. PAT. OFF.

Balanced pressure non-flash mixer for extra safety
 Gas pressure control for uninterrupted welding
 Welds ferrous and non-ferrous metals

\$96⁹⁵ **\$10**
 cash down

Weld ferrous and non-ferrous metals with oxygen and acetylene; non-ferrous metals with oxygen and LP-gas (bottled propane, butane or mixtures of both). Braze, solder, heat, bend, etc. with oxygen and acetylene or LP-gas. All parts solid brass, bronze or monel metal. . . ground and hand fitted to eliminate leaks. Double "O" ring seat for leak-free connection of gooseneck to torch. . . tighten with hand. Oxygen regulator with safety relief valve. Forged bronze-bodied regulators have 2 pressure gauges with brass cases. . . 0 to 100 and 0 to 4,000 lbs. on oxygen regulator; 0 to 30 and 0 to 500 lbs. on acetylene regulator.

17 1/2-inch torch (use either hand) can be turned off without disturbing setting of regulator. . . fluted grip. 6-inch forged Naval bronze gooseneck will not bend. *Four times tested and approved for your safety:* (1) Underwriters' Laboratories, Inc. (2) Associated Factory Mutual Insurance Companies. (3) Sears merchandise testing laboratories. (4) N.Y.F.D. Certificate of Approval No. 906. *Includes:* 5 wide-

range welding tips (AA-1, AA-2, AA-3, AA-4, AA-5) of one-piece swaged solid drawn copper; won't flash back. CRAFTSMAN 2-stage Oxygen Regulator and 2-stage Acetylene Regulator. 25 ft. of "Siameez" hose (see 9M5427 on opposite page); assorted welding rods, 1 lb. universal flux; 50-mm professional welder's goggles, spark lighter; wrenches; 271-page illustrated *Welders' Handbook*.

Outfit may be used for cutting with Cutting Attachment 9M5477, and 9M5447, 9M5467 Cutting Tips (for acetylene) or 9M5478 Cutting Tips (for LP-gas*) on opposite page. *Cutting Attachment and cutting tips not included with outfit.*

99 M 5422K—CRAFTSMAN 2-stage Oxy-Acetylene Welding Outfit. Shipping wt. 27 lbs. \$10 down. cash \$96.95
 Convert your single-stage welding outfit to 2-stage with regulators below. \$3.50 down on Easy Terms.

99 M 5438—CRAFTSMAN 2-stage Acetylene Regulator. Shipping weight 5 pounds 8 ounces. \$32.50

99 M 5437—CRAFTSMAN 2-stage Oxygen Regulator. Shipping weight 5 pounds 8 ounces. 32.50

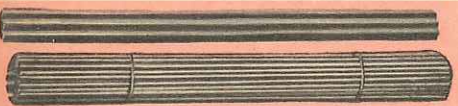

Gas Rod Assortment. 106 rods (18-in.) (some flux coated) with two 4-oz. cans of flux. For welding, brazing most metals. Rods incl.: four 3/32-in. aluminum; six 1/16-in. die-cast zinc; 72 copper-coated steel (1/16, 3/32, 1/8, 3/16-in.); four 1/8-in. cast iron; sixteen 3/32 and 1/8-in. bronze; four 3/32-in. flux-coated bronze rods.
 99 M 20496—Shipping weight 5 lbs. 11 oz. \$4.89

"Hot Rodder" Welding Rod Assortment. For auto repair hobbyists, repair shops. All rods 24 in. except 18-in. Aladdin rods. 1 lb. ea. of 1/16 and 3/32-in. copper-coated rods; 1 lb. ea. of 3/32 and 1/8-in. Hi-Test frame rods. Includes assortment of 3/32-in. flux-coated and nickel-silver brazing rods, 1/8-in. die-cast Aladdin rods.
 99 M 20492—Shipping weight 5 lbs. 14 oz. \$3.98

Copper-coated Gas Welding Rods. For mild steel.
 99 M 20401C—1/16 x 36 in. (about 160 rods) Wt. 6 lbs. . . . \$2.19
 99 M 20403C—3/32 x 36 in. (about 70 rods) Wt. 6 lbs. . . . 1.98
 99 M 20405C—1/8 x 36 in. (about 40 rods) Wt. 6 lbs. . . . 1.89

Gas Brazing Rods. For steel, cast iron, copper alloys.
 99 M 20451C—3/32 x 36 in. (pkg. of 13) Wt. 2 lbs. . . . \$1.98
 99 M 20453C—1/8 x 36 in. (pkg. of 6) Wt. 2 lbs. 1.59
 99 M 20455C—3/16 x 36 in. (pkg. of 3) Wt. 2 lbs. 1.49

Flux-coated Gas Brazing Rods. Wt. 1 lb. 4 oz.
 99 M 20464—3/32 x 18 in. About 25 rods. One-lb. pkg. . . . \$1.98
 99 M 20466—1/8 x 18 in. About 14 rods. One-lb. pkg. . . . 1.98

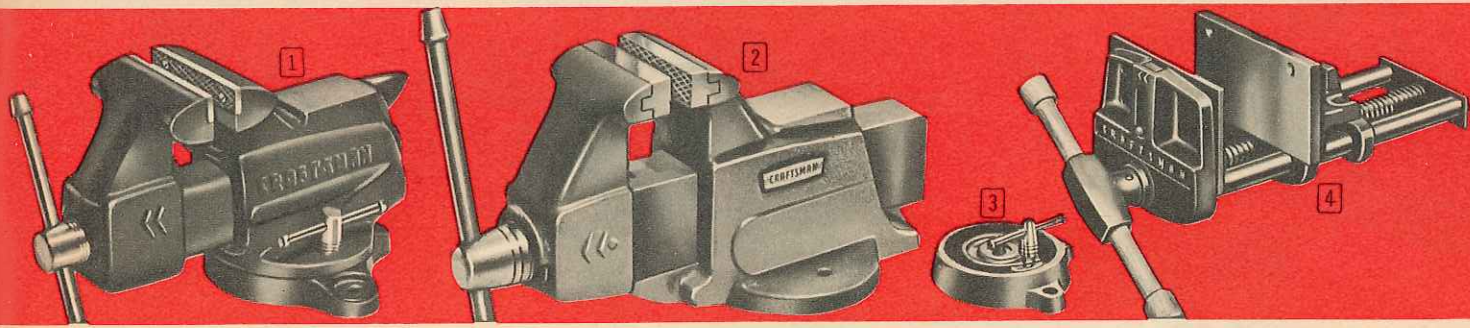

CRAFTSMAN Vises . . precision-built for non-slip gripping action

1 Bench Vise. Heavy-duty steel channel. Completely enclosed, protected screw. Built-in pipe jaws. Slanted swivel locking lever. Vise swivels 180° on base, locks at any angle.
 Screw handle ball ends forged from handle stock, Nickel-plated handle, screw, lock nut. Acme-threaded steel screw. . . seated in replaceable malleable iron nut. Reinforced body. Replaceable jaw faces.

Catalog Number	Jaw size	Open to	Holds pipe	Wt. lbs.	Price
99M5180C	3 1/2 in.	4 in.	3/8-1 1/4 in.	19	\$10.29
99M5181L	5 in.	5 in.	1/2-1 1/2 in.	42	19.98

2 Machinists' Vise. Strong, malleable iron castings are guaranteed unbreakable. Replaceable hardened tool steel jaw faces with "T" section design for precision tongue and groove fit. . . pinned to casting; no screw holes or heads in work face. Self-lubricating graphite-bronze bearing in front of sliding jaw bears thrust of steel screw head. . . supports screw rigidly. Steel beam covers and protects screw. Meets U.S. Government Specifications No. GGG-V-436-C.

(2) Stationary-base Machinists' Vises					(3) Swivel Base Conversion Kits			
Catalog Number	Jaw size	Opens to	Shipping weight	Price	Catalog Number	Fits Vise	Shipping weight	Price
99 M 5182K	3 1/2 in.	.5 in.	.33 lbs.	\$26.95	9 M 5185	99 M 5182K	7 lbs.	\$5.98
99 M 5183L	4 in.	.6 in.	.43 lbs.	32.95	9 M 5186	99 M 5183L or 99 M 5184L	8 lbs. 5 oz.	6.98
99 M 5184L	4 1/2 in.	.7 in.	.50 lbs.	38.95				

3 Swivel-Base Kit. Converts stationary-base vise to a more versatile swivel-base vise. Swivels full 360°. . . geared lock bolt locks tight. With swivel-base, lock bolt, nut and handle, center bolt, washer, spacer, plug for 1 hole.

4 Rapid-acting Woodworker's Vise. Just turn handle in counter-clockwise direction and front jaw pulls open as easily as opening a drawer. Push jaw closed. . . clockwise turn clamps work tightly. Retractable dog in front jaw acts as bench stop. Drilled for mounting wood faces. Guide rods keep jaws parallel and aligned. Template for easy installing. *Hardwood handle.*

Catalog Number	Jaw size	Opens to	Wt. lbs.	Price
99 M 5188K	4 x 7 in.	9 in.	30	\$16.79
99 M 5189K	4 x 10 in.	12 in.	37	19.49

You can equip an entire workshop for only a few dollars down . . . see inside back cover

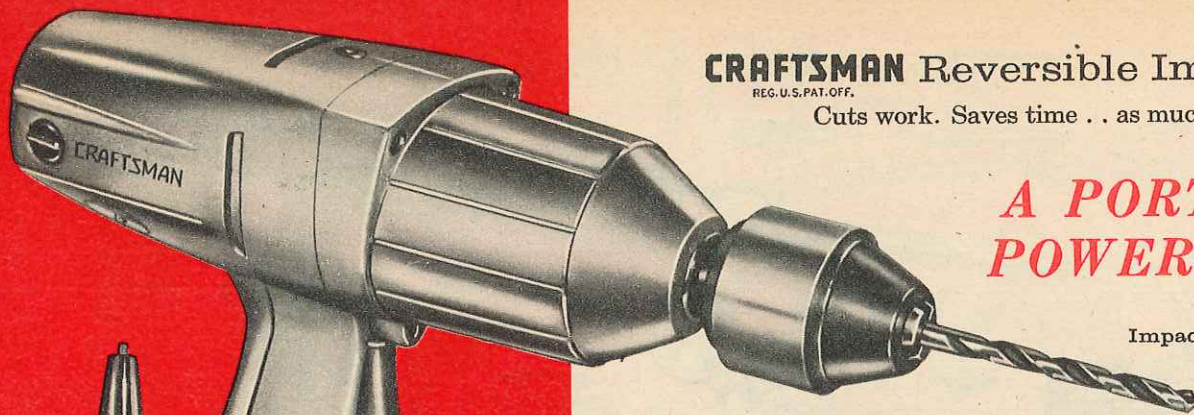

CRAFTSMAN Reversible Impact Tool

REG. U.S. PAT. OFF.

Cuts work. Saves time . . . as much as 90%

A PORTABLE POWERHOUSE

Impact Tool only **\$69⁹⁵** cash
\$5 down

- Tighten or remove nuts, bolts, studs
- Drive or remove screws
- Free broken studs, bolts, frozen nuts

- Tap and thread in metals
- Bore holes in wood
- Drill holes in metal or masonry

Time—that's what this versatile tool saves you. It furnishes the brute power to do so many jobs easier, faster, better. Cuts as much as 90% of the time needed to run in, set or remove nuts, bolts, screws. Scores of uses in automotive repair shops, gas stations, shop maintenance, or on farms and construction jobs. Will operate off AC-DC portable motor generator sets.

We sincerely believe it is the best value you can find anywhere in an impact tool. And, *it is guaranteed one full year against defects.*

A 4-ampere motor gives impact power to spare—as much as 150 foot-pounds of driving torque at 1900 rotary impacts per minute. Takes 1/2-in.

square-drive impact sockets. Aluminum alloy housing. Grease sealed ball bearings. Reverse switch and on-off trigger switch on handle. Auxiliary handle permits two-hand operation for better control. *UL listed (Industrial Standards).* 110-120-volt, 25-60 cycle AC-DC. With 10-ft. 3-prong safety cord and adapter.

9 M 1885—Impact Tool only, without chuck, bit or case. Shipping wt. 11 lbs. \$5 down. . . . Cash \$69.95

99 M 1885C—Impact Tool with Chuck (below) and Carrying Case. Wt. 19 lbs. \$5 down. . . . Cash \$79.95

9 M 2253—Impact Chuck only. 1/4 to 1/2-inch capacity. 1/2-in. square drive. Holds twist or masonry drills, bits, taps. Shpg. wt. 1 lb. 6 oz. \$8.98

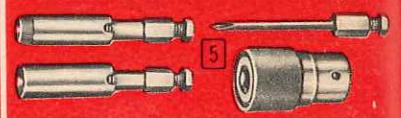
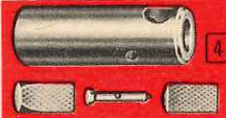
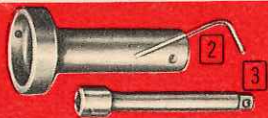
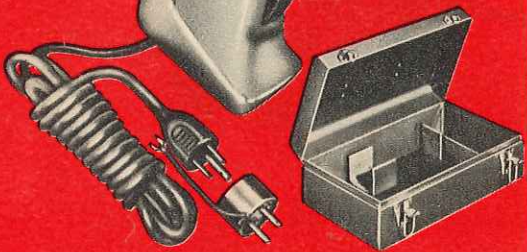

Buy these Accessories to make your impact tool a "Jack-of-all-trades"

1 Impact Sockets. 1/2-inch square drive. 6-point openings. Available in the following sizes: 7/16, 1/2, 9/16, 5/8, 11/16, 3/4, 13/16 and 7/8-inch. *Be sure to state size wanted when ordering impact sockets.* Shipping wt. each 6 oz. 9 M 4400—Each. 69c

2 Die Holder. For threading or re-threading rods, studs, bolts. Takes up to 1 1/2-in. diameter round dies; setscrew holds dies securely. Made of tough forged steel. Shipping weight 13 ounces. 9 M 2289. \$6.49

3 6-inch Extension. Makes it easier to reach tight places. 1/2-inch square drive. For use with CRAFTSMAN Impact Tool above and Impact Sockets described at left. Shipping weight 13 ounces. 9 M 4477. \$1.19

4 Stud Driver and Remover. Speeds the setting or removing of studs 3/8 to 1/2 inch in diameter. Design permits solid grip on short or broken studs or bolts. Shipping weight 1 pound 2 ounces. 9 M 1886. \$3.98

5 Screwdriver Chuck and Bits. Drives or removes machine or wood screws rapidly. Includes collet chuck, Phillips No. 2 bit, 2 flat bits with finders (No. 12 and 14). Shipping weight 1 lb. 2 oz. 9 M 18862. \$12.98



CRAFTSMAN 2-speed Sander-Polisher-Drill

REG. U.S. PAT. OFF.

let's you select the right speed for the job . . .

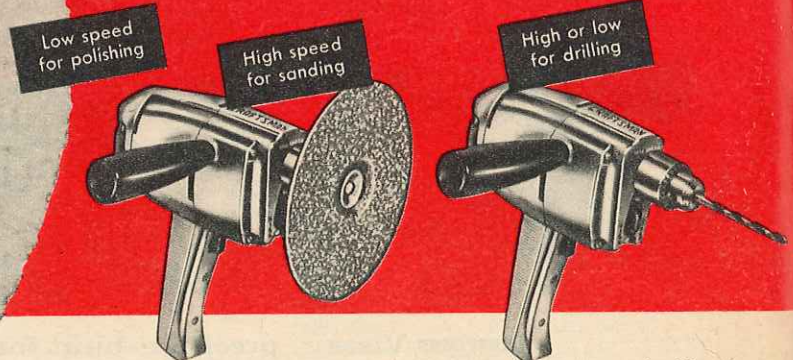

• Guaranteed for 1 year against defects
A combination tool with the right speed, weight and flexibility for dozens of uses in workshop or home. *Plus Power* motor develops 1/5 HP. High speed of 2000 RPM gives smooth-finish sanding; low speed of 950 RPM polishes or buffs without danger of burning wax. It's an ideal tool for polishing automobiles, kitchen cabinets, woodwork or furniture . . . *the easy way!*
With 3/8-in. keyed chuck (sold separately) you can drill holes at high speed up to 1/2-in. diam. in wood; up to 1/4-in. diam. in metal. For 1-in. diameter holes in wood or 3/8-in. diameter in metal, simply switch to low

• Underwriters' Laboratories Listed
speed. In close quarters, you can remove the auxiliary handle, or mount it on the other side . . . for left or right-hand use.
Aluminum alloy housing. Trigger switch has safety lock . . . stays on for continuous running. With 6-foot, 2-wire cord for 110-120-volt, 60-cycle AC.
Comes with 5-inch rubber back-up disc, polishing bonnet and 6 sanding discs (2 fine, 2 medium, 2 coarse grit). Drill bit not included. Shpg. wt. 5 lbs. 14 oz.
9 M 2776—Without Key-chuck. \$24.95
9 M 21472—3/8-in. Key-chuck with 3/8 in. x 24 male adapter. Shpg. wt. 15 oz. \$5.80

Only **\$24⁹⁵** cash
Without Key-chuck
\$2.50 down

BUY NOW ON SEARS EASY TERMS . . . see inside back cover

CRAFTSMAN 1/2-inch Electric Drill

REG. U.S. PAT. OFF.

Convenient . . Rugged . . Powerful

REVERSIBLE

. . . for easier, deep hole drilling. If chips clog bit, just thumb the reversing switch to back out of trouble. Far easier to drill deep holes in wood and metals.

\$39⁹⁵
cash

\$4 down

Forward—backward—you can change drill bit rotation as fast as you can say it. Just flick the reversing switch. The easy, convenient way to back out a stuck drill bit or auger. Ideal for use in woods with a high resin content, or in creosote-treated logs and poles and other "wet" woods. Excellent for extending electrical wiring and piping on home remodeling jobs.

Plus Power motor develops over 1/2 HP . . plenty of power to handle the toughest jobs. Electricians, plumbers, linemen, maintenance workers

and home craftsmen will like its ruggedness and handling ease. Compact aluminum alloy housing lets you reach into small areas.

Triple-reduction gears of hardened alloy steel and ball-thrust bearing equip this drill for rough duty. Oil impregnated bearings. *UL approved (Industrial Standards). Fully guaranteed for ONE year (see guarantee below). For 110-120-volt, 25-60 cycle AC-DC. 7-ft. 3-wire cord; adapter. With key-chuck but without drill bit shown.*

9 M 2596—Shipping weight 10 pounds . . . \$39.95

GUARANTEE—CRAFTSMAN Electric Drills showing defects in materials or workmanship will be repaired or replaced at no charge if returned within one year of the date of purchase.

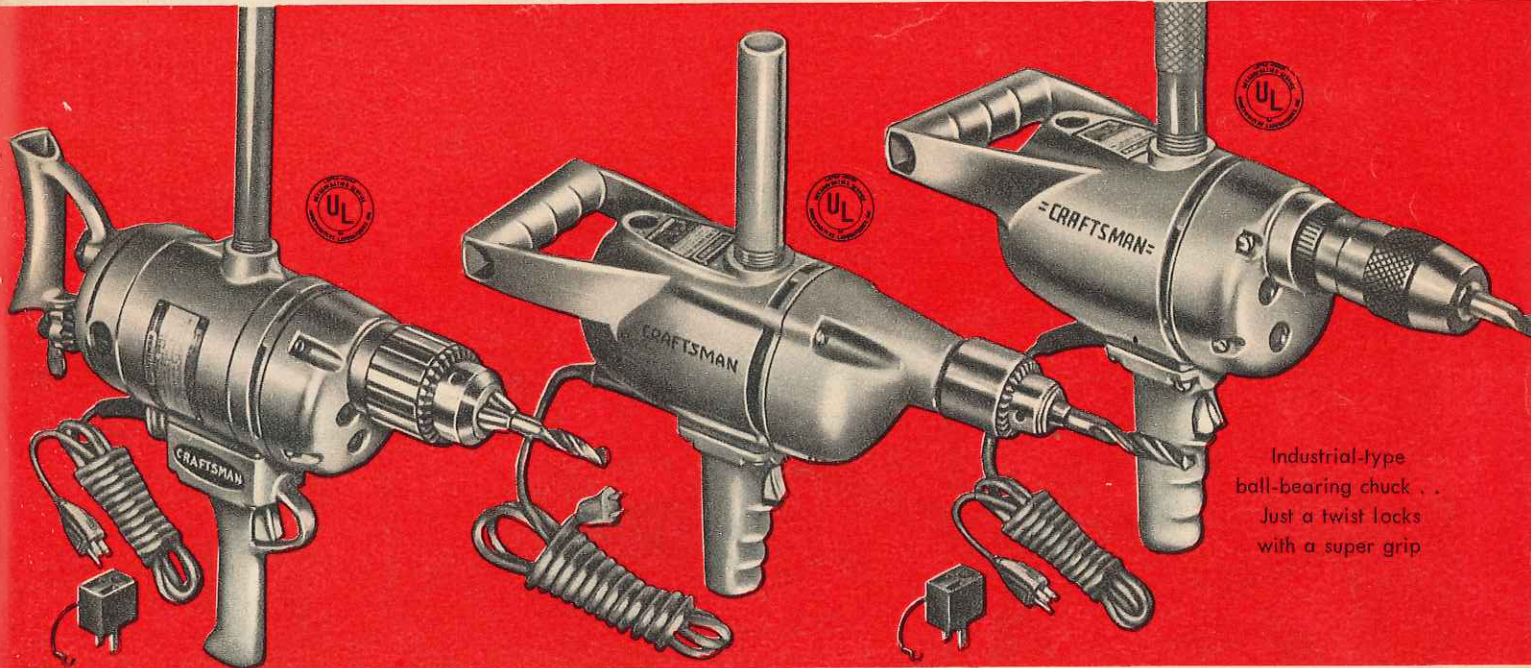
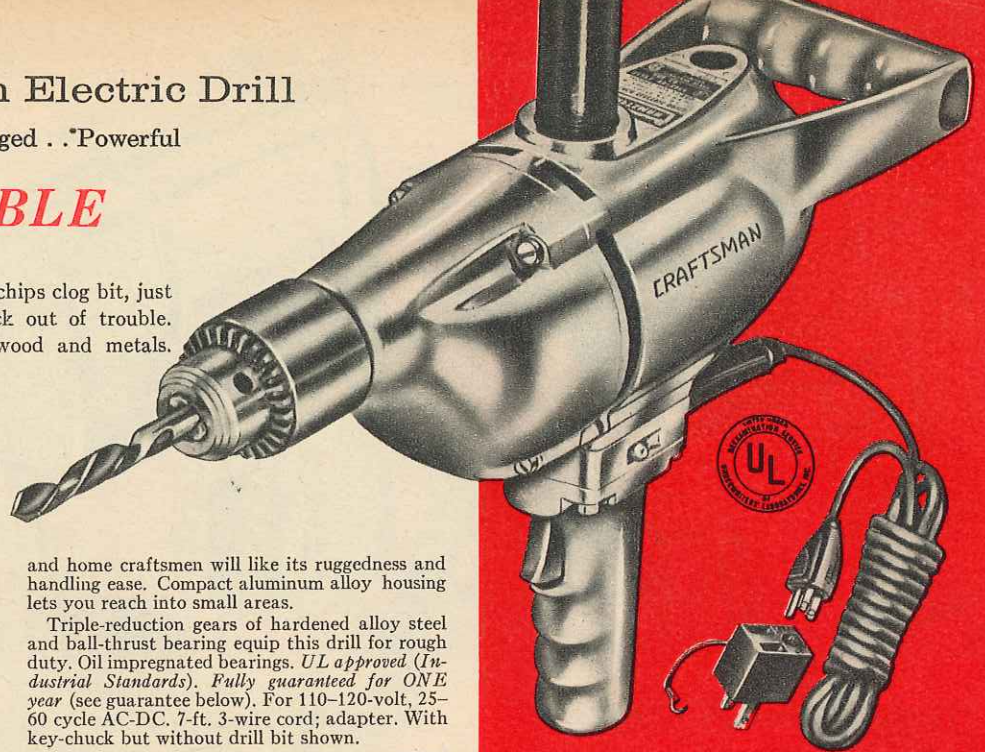

Industrial-type ball-bearing chuck . . . Just a twist locks with a super grip

CRAFTSMAN 3/4-inch Production-type Drill

\$79⁹⁵ \$5 down
cash

For continuous heavy-duty use in shop or factory. Our finest professional drill. Meets the most exacting standards of industrial production (including industries engaged in heavy construction). *Guaranteed ONE year against defects in materials and workmanship.*

More than 1 HP delivered by powerful motor. Hardened triple-reduction gears develop great torque—more than enough to cut the hardest metals fast and clean. Ball and needle bearings throughout equip this model for the roughest usage.

Double-pole switch locks for continuous running. For tight spaces, top and rear handles are removable. No-load speed 300 RPM; full load 175 RPM. *UL approved (Industrial Standards).* With 10-ft. 3-wire cord, 25-60 cycle AC-DC. Bit not included.

99 M 2587K—Shipping weight 22 pounds . . . \$79.95

CRAFTSMAN 1/2-inch Close-quarters Drill

\$29⁹⁵ \$3 down
cash

For hard-to-reach places. Compact in size, yet motor develops over 3/4 HP. Inexpensive but has features of more costly drills. Lightweight (only 7 lbs. 12 oz.) yet has the power and chuck capacity for heavy work. Ideal for electrician, installation or repair man; easy handling for light garage or farm use. Removable top handle. *Guaranteed ONE year.*

Drives 1/2-inch bit into steel and 1-inch bit into hardwood without stalling. No-load speed 425 RPM. Permanently lubricated oil-impregnated bearings. Ball-thrust bearing on spindle. Triple-reduction hardened steel alloy gears. *UL approved.*

Aluminum alloy housing. Trigger switch. 14 in. long from key chuck to handle. For 110-120-volt, 25-60-cycle AC-DC. 7-ft. 2-wire cord. Bit not included.

9 M 25833—Shipping weight 10 pounds . . . \$29.95

CRAFTSMAN 1/2-inch Continuous-duty Drill

\$49⁹⁵ \$5 down
cash

Our newest and finest 1/2-inch drill—with the best chuck we've seen. Just twist to lock on drill bits with a vise-like grip; unlock as easily. The same type chuck used in industrial machines for precision work. Plus Power motor develops over 3/4 HP.

A time-saver for contractors, electricians, light industry. Ball-bearing armature. Triple reduction gears. Handles and balances well; 13 inches long. Top handle is removable for work in small spaces. *UL approved (Industrial Standards). Guaranteed ONE year.*

No-load speed 550 RPM; full load about 350 RPM. 7-foot, 3-wire cord, unbreakable plug and adapter. Double pole switch. Drill bit shown not included.

9 M 25802—Shipping weight 12 pounds . . . \$49.95

9 M 2305—Chuck only. 0 to 1/2-inch capacity. 3/4 x 16 thread. Shipping weight 2 pounds 3 ounces . . . \$16.98

For a wide selection of drill bits, turn to page 52

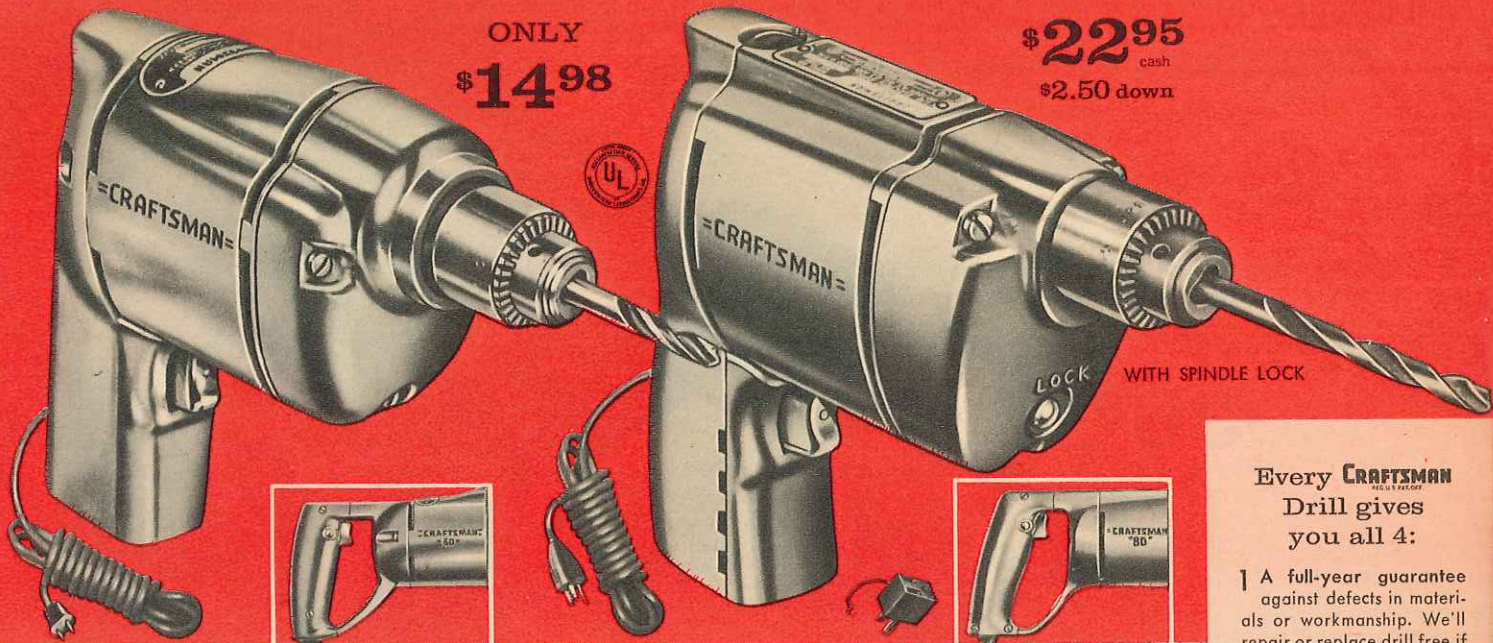

ONLY
\$14.98

\$22.95
cash
\$2.50 down

Every **CRAFTSMAN**
Drill gives
you all 4:

- 1 A full-year guarantee against defects in materials or workmanship. We'll repair or replace drill free if returned within 1 year from date of purchase.
- 2 Rugged construction. Die-cast aluminum-alloy housing . . . lightweight . . . well-balanced.
- 3 Universal motor, 110-120-volt, 25-60-cycle AC-DC . . . easily drives all Sears drill accessories without overheating.
- 4 Complete Underwriters' Laboratories approval. Craftsman drills with 3-wire cord meet UL Industrial Standards.

CRAFTSMAN Medium-duty Drill

1/4-inch capacity . . . ideal tool for the handyman

- Smooth-running motor develops 1/8 HP
- Bronze sleeve bearings (oil impregnated)

Especially for hobbyists or home handymen who demand rugged dependability with power to handle most accessories. No-load speed of motor, 2250 RPM; full-load speed about 1700 RPM . . . a powerful tool at this low price.

Precision-gearred key chuck. Single reduction steel gears. Locking trigger switch. With 6-foot 2-wire cord. Without bit. *See more big features at right.*

- 9 M 790—Pistol-grip Drill without case, 7 3/4 inches long. Shipping weight 3 pounds 8 ounces. . . . \$14.98
- 9 M 18315—Above Drill with metal case. Shipping weight 9 pounds 3 ounces. . . . 18.98
- 9 M 791—Saw-grip Drill without case, 10 1/2 inches long. Shipping weight 3 pounds 12 ounces. . . . 14.98
- 9 M 18325—Above Drill with metal case. Wt. 9 lbs. 7 oz. . . . 18.98

CRAFTSMAN Heavy-duty 1/4-in. Drill

Built for professional tradesmen who *must* have more power

- Rugged motor develops 1/5 HP . . . handles tougher jobs
- Ball, needle and sleeve (oil impregnated) bearings

For sustained heavy duty . . . operates for extended periods without power loss caused by overheating. Greatly improved with spindle lock that enables you to change accessories faster and easier, and there is plenty of power to handle *all* Sears drill accessories. No-load speed of motor, 1900 RPM; full-load speed about 1200 RPM.

Double reduction gears. Minimum chuck offset for close-quarter work. Polished housing. Fan ventilation keeps drill comfortable to handle. *UL approved (Industrial Standards).* With 10-foot 3-wire cord, plug and adapter. Without bit. *See more big advantages at right.*

- 9 M 772—Pistol-grip Drill, 7 3/4 inches long. Shpg. wt. 4 lbs. . . . \$22.95
- 9 M 18385—Above Drill with metal case. Wt. 9 lbs. 11 oz. \$3 down. . . . Cash 26.95
- 9 M 773—Saw-grip Drill, 10 1/2 inches long. Shpg. wt. 4 lbs. 4 oz. . . . 22.95
- 9 M 18395—Above Drill with metal case. Shipping weight 9 lbs. 15 oz. . . . 26.95

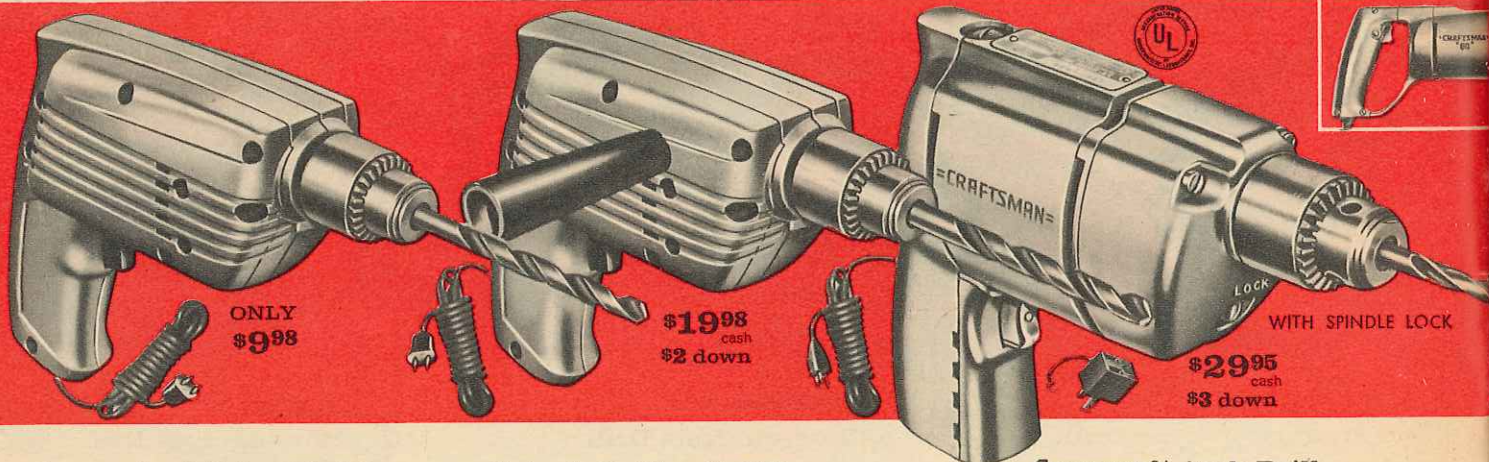

Low-priced 1/4-in. Model
1/8 HP for light-duty work

A very low price for an electric drill equipped with a geared key chuck. Small and compact . . . exceptionally easy to handle . . . will fit into tight places for close-quarter work. Not recommended for use with heavy-duty drill accessories.

Oil-impregnated, self-lubricating precision sleeve bearings. Double reduction gears. Painted die-cast aluminum alloy housing. Locking trigger switch. Safety release on switch. *Guaranteed 90 days against defects.*

- With 6-foot 2-wire cord, plug. For 110-120-volt, 25-60-cycle AC. Without bit.
- 9 M 799—Shipping weight 3 lbs. 12 oz. . . . \$9.98

3/8-inch Drill . . . 1/4 HP
Big capacity . . . yet low priced

Big chuck capacity and slower speeds . . . delivers more power than 1/4-inch drill . . . handles heavier jobs. A fine drill for general use. *Guaranteed 90 days against defects in materials or workmanship.*

Precision sleeve (oil-impregnated) bearings. Double reduction gears. Precision-gearred key chuck; 1/16-inch to 3/8-inch capacity. Die-cast aluminum alloy frame . . . lightweight but rugged.

Universal motor for 110-120-volt, 25-60-cycle AC. No-load speed, 1150 RPM; full-load about 880 RPM. Locking trigger switch for continuous running . . . switch has safety release. 8 1/2 inches long with auxiliary handle. With 6-foot 2-wire cord, plug. Without bit.

- 9 M 788—Shipping weight 4 pounds 13 ounces. . . . \$19.98

CRAFTSMAN 3/8-inch Drill
. . . 1/4 HP for tough jobs

Heavy duty . . . greater chuck capacity than 1/4-inch drill, and slower speeds for extra power. An exceptionally low price for an industrial-rated 3/8-inch drill of this fine quality.

Has advanced spindle lock for fast, easy changing of chuck or attachments. No-load speed, 1150 RPM; full-load speed about 880 RPM . . . drill will handle *all* Sears drill accessories.

Precision ball, needle and sleeve (oil impregnated) bearings. Double reduction steel gears. Precision-gearred key chuck. *UL approved (Industrial Standards).* With 10-foot 3-wire cord, plug and adapter. *See other features at top of page.* Without bit.

- 9 M 775—Pistol-grip Drill, 8 1/2 in. Shpg. wt. 4 lbs. 12 oz. . . . \$29.95
- 9 M 18355—Above Drill with metal case. Wt. 11 lbs. \$3.50 dn. . . . Cash 33.95
- 9 M 774—Saw-grip Drill, 11 3/4 in. Shpg. wt. 4 lbs. 12 oz. . . . 29.95
- 9 M 18345—Above Drill with metal case. Shpg. wt. 11 lbs. . . . 33.95

CRAFTSMAN 5/16-inch Industrial Drill

Continuous duty for really tough drilling jobs



\$36⁹⁵
cash

Only \$4 down

With CRAFTSMAN Industrial Chuck
Ball-bearing mounted for smooth, even operation. Finger-tip twist locks bit with a super grip! No key needed.

Also has advanced Spindle Lock for fast changing of chuck or accessories



Really powerful motor develops 2/5 HP Ball and needle bearings throughout this drill

Built with the balance and feel of a 1/4-inch drill, yet develops *twice* the horsepower! Definitely for the craftsman who demands the very best in tools, for it meets the exacting requirements of professional and industrial use. Extra-rugged 3-jaw tool steel chuck . . . the same type used on industrial machines where tremendous grip and accuracy count most. Just flip the chuck collar, and the bit locks rigidly in place . . . grips with the power of a vise . . . won't slip under heaviest drilling loads. Chuck unlocks quickly with the same easy twist. You can change drill bit sizes fast and easy . . . without fumbling with a key.

No-load speed, 1800 RPM; full-load about 1200 RPM. Double reduction chrome-moly-steel gears. Convenient locking trigger switch. Handles *all* Sears drill accessories . . . tackles tough, sustained drilling jobs without stalling or over-heating. *Completely UL approved (Industrial Standards).*

With 10-foot 3-wire cord, unbreakable plug and adapter. Drill bit is not included. See 4 more big features on opposite page.

- 9 M 781—Pistol-grip Drill, 7 1/2 inches long. Shpg. wt. 6 lbs. 2 oz. \$36.95
- 9 M 18374—Above Drill with metal case. Shpg. wt. 12 lbs. \$4.50 down Cash 40.95
- 9 M 780—Saw-grip Drill, 10 3/4 inches long. Shpg. wt. 6 lbs. 2 oz. 36.95
- 9 M 18364—Above Drill with metal case. Shipping weight 12 lbs. 40.95
- 9 M 2304—Chuck only, 0 to 5/16-in. capacity. 3/8-in. x 24 thread. Wt. 14 oz. 14.98

Stands for electric hand drills .. Drill Case

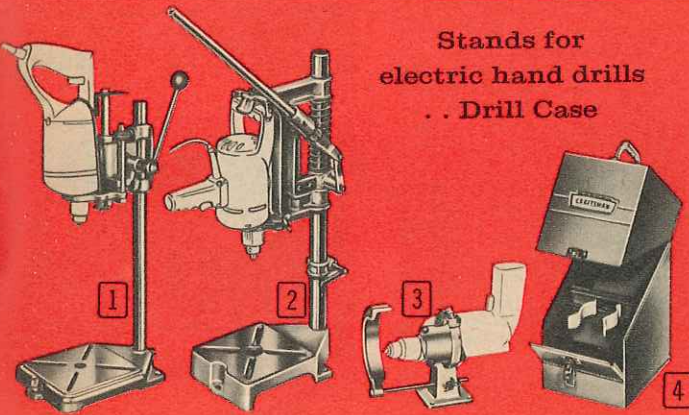

1 Feature-packed Electric Drill Stand. Universal mounting bracket fits all Sears 1/4-inch and 5/16-inch electric drills (fits most competitive models too).

Locking depth gauge has 0 to 3-inch depth range. 4 1/2-inch throat depth. 18 inches high overall; 1-inch tubular column. 6x6-inch slotted working surface. Cast aluminum frame.
9 M 2592—Shpg. wt. 7 lbs. 14 oz. . . \$10.98

2 CRAFTSMAN Electric Drill Stand. Converts drills (9M25833 and 9M25802 on page 49) to drill presses. 27 inches high overall. Throat depth, 6 inches. Head rotates 360°. 7 1/2 x 7 1/2-inch working surface.
99 M 2563K—Shpg. wt. 26 lbs. . . . \$24.95

3 CRAFTSMAN Electric Drill Bench Stand. Fits 1/4-inch and 5/16-inch drills. Easily converts drill to bench tool for wire brushing, sharpening, sanding, etc.

Has protective wheel guard. Dimensions: Width, 3 inches; length, 3 inches; height, 8 inches.
9 M 2591—Shpg. wt. 1 lb. 4 oz. . . . \$2.19

4 Metal Carrying Case for Drills. For 1/4-inch, 5/16-inch and 3/8-inch drills. Protect your drill with this sturdy steel case. Has a bit holder and two compartments for accessories. Takes everything you need right to the job. Flip-down front for easy access. Dimensions: 6 1/2 x 7 1/2 x 13 inches.
9 M 1486—Shpg. wt. 5 lbs. 11 oz. . . \$4.98

Recoil Extension-Cord Reel

For portable power tools. A very handy accessory in any shop or garage. Provides compact cord storage. Brings a neat, straight line of power anywhere it's needed. Eliminates tangled wire . . . keeps the wire out of your way.

15-foot, 3-wire rubber-covered service cord rolls in and out easily at a smooth, even speed. Cord "latches" in position . . . a slight pull "unlatches" it for extension or retraction. Eye-bolt mounting permits installation on wall or ceiling. *Approved by Underwriters' Laboratories.* 18-gauge, 3-prong plug. Adapter included for changing to 2-prong plug.
9 M 25024—Shpg. wt. 4 lbs. 4 oz. . . . \$10.98

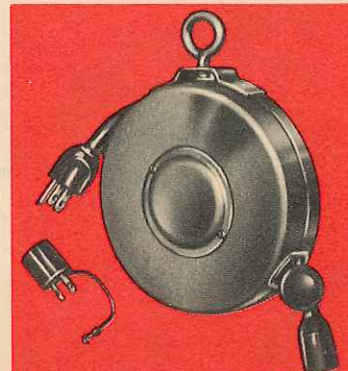

BUY ON EASY TERMS . . . see inside back cover for details



\$44.95
cash
\$4.50 down

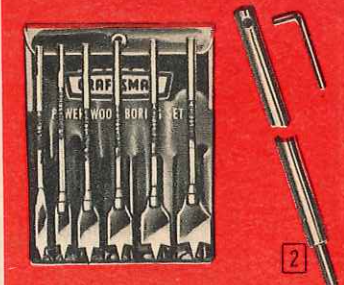

CRAFTSMAN Power Wood Boring Bits. New design permits quick, easy boring with 1/4 or 1/2-inch power drills or drill press. Bores smooth, accurate holes (3/8 to 1 1/4-inch diameter; up to 5 inches deep) in hard or soft wood in ANY direction . . . even through knots. Chips clear automatically. Made of alloy steel. 6 1/2 inches long.

9 M 2092—Set of 6. One each of sizes up to 1 in. below. Wt. 12 oz. Set **\$3.69**

Individual Power Boring Bits.

Catalog No.	Size	Shpg. wt.	Each
9 M 2093	3/8 in.2 oz.59c
9 M 2094	1/2 in.2 oz.59c
9 M 2095	3/4 in.3 oz.69c
9 M 2096	1 in.3 oz.69c
9 M 2097	1 1/4 in.3 oz.79c
9 M 2098	1 in.3 oz.79c
9 M 20982	1 1/8 in.4 oz.79c
9 M 20983	1 1/4 in.5 oz.79c

CRAFTSMAN 55-piece Electric Drill Kit

REG. U. S. PAT. OFF.

The most powerful and versatile drill set we sell

This remarkably complete drill set has, all you need for practically every type of drilling in wood, masonry or metal. Contractors use every accessory in construction of buildings from foundations to roof—from drilling holes to bolt joists and frames to drilling lifting holes in stone masonry.

Choice of pistol-grip (9 M 772) or saw grip (9 M 773) CRAFTSMAN Drill (see page 50). 1/2-HP motor; 110-120 volt, 25-60 cycle AC-DC. Handles heaviest loads without overheating. *UL approved (Industrial Standards).*

Complete set also includes: 6 solid shank power wood boring bits (diameters 3/8 to 1 inch); 4 carbide-tipped masonry drill bits (sizes 1/4 to 1/2 inch) for drilling in concrete, brick, stone, etc. 13 high-speed jobber-length drill bits (sizes 1/16

to 1/2 inch) for use in wood or metal; 13-piece wood screw pilot bit set (includes depth adapter) for screw sizes 4 to 12; twelve 6-inch sanding discs; 5 1/2-inch rubber back-up disc; adapter and 6 1/4-inch lamb's wool polishing bonnet give you exceptional polishing results when used on cars, shoes, metal, etc.

Set comes packed in 7 1/2x10x13-inch steel carrying case with clip-type drill mounting; two compartments for other accessories; plus portable drill bit holder for ALL 36 bits in set. *Only \$4.50 down on Sears Easy Terms.* Shipping weight of set 15 pounds.

- 99 M 18013C—With Saw-grip Drill. Cash \$44.95
- 99 M 18023C—With Pistol-grip Drill. Cash 44.95

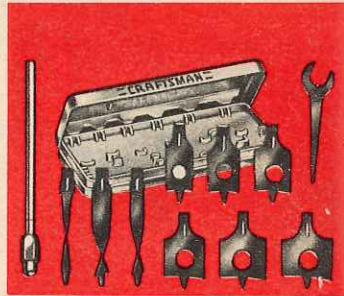

CRAFTSMAN 10-pc. Interchangeable Wood Bit Set. Interchangeable cutters with a single shank. Bore easily in all woods, pressboard, plastic, plywood, etc. Fit 1/4-in. electric drills and drill presses. Sizes 1/4, 3/8, 1/2, 5/8, 3/4, 7/8, 1, 1 1/8, 1 1/4 inch. Plastic case.

9 M 2082—Shipping weight 9 ounces. **\$3.29**

2 12-inch Power Bit Extension.
9 M 2090—With setscrew wrench. 3/8-in. diam. Fits bits above. Shipping weight 10 ounces. **\$1.59**



CRAFTSMAN Wood Screw Pilot Bits. For countersinking, counterboring.

9 M 4204—13-pc. Set. One each of sizes listed under 9 M 4201 below plus "stop". Plastic pouch. Shpg. wt. 1 lb. **\$3.98**

9 M 4203—5-pc. Set. Sizes 4-5x3/8 in.; 6-7x3/4 in.; 8-9x1 in.; 8-9x1 1/4 in.; 10-12x1 1/2 in. Adjustable "stop". Shpg. wt. 8 oz. **\$1.69**

9 M 4201—Individual Wood Screw Pilot Bits. State length, size.

Length	Screw Size	Shpg. wt.	Each
1/2 in.	4 and 52 oz.29c
3/8 in.	4 and 52 oz.29c
3/4 in.	4 and 52 oz.29c
3/8 in.	6 and 72 oz.29c
3/4 in.	6 and 72 oz.29c
1 in.	6 and 72 oz.29c
3/4 in.	8 and 92 oz.29c
1 in.	8 and 92 oz.29c
1 1/2 in.	8 and 92 oz.29c
1 in.	10 and 122 oz.29c
1 1/4 in.	10 and 122 oz.29c
1 1/2 in.	10 and 122 oz.29c

CRAFTSMAN Heavy-duty 1/4-inch 42-piece Drill Kit

A good basic kit to start a home workshop . . . helps to do repair jobs in a professional way.

Designed primarily for woodworking by the home craftsman or small shop owner, but with enough power for car buffing and drilling 1/4-inch holes in steel. Your choice of pistol-grip (9 M 790) or saw-grip (9 M 791) drills described on page 50. Built for intermittent duty.

Set also includes 10 high-speed jobber-length drill bits (sizes 1/16 to 1/2 inch) for wood or metal; 9-piece power wood bit set (sizes 1/4 to 1 inch); 5 wood-screw pilots for drilling, countersinking or counterboring holes for wood screws (for screw sizes 4 to 12), twelve 5-inch sanding discs; 4 1/4-inch rubber back-up disc; adapter; and 5 1/2-inch lamb's wool polishing bonnet. Packed in a 6 1/2x7 1/2x13-inch steel case. Shipping weight 11 pounds. *Only \$3.00 down on Sears Easy Terms.*

- 9 M 1825—With Pistol-grip Drill. Cash \$27.95
- 9 M 1826—With Saw-grip Drill. Cash 27.95

Light-duty 32-piece 1/4-inch Electric Drill Kit

Ideal for those occasional jobs and repairs around the house. Covers wide range of jobs from drilling in metal to polishing silverware or sharpening knives. It's a real handyman's tool.

Accessories are powered by 1/2-HP drill with geared key chuck. Use on 110-120 volt, 60-cycle AC only. Handy and compact for easy carrying.

Set also includes: Five high-speed drill bits; twelve 5-inch sanding discs; a rubber back-up disc; grinding wheel; grinding wheel arbor; two-piece buffing wheel; buffing bonnet; one bar of buffing compound; wire wheel; five-piece screw pilot set; arbor. Also includes a 7x4x1 1/4-inch metal box for carrying and safe storage. Guaranteed against defects in materials, workmanship.

9 M 18402—Shipping weight 8 lbs. 10 oz. **\$19.98**

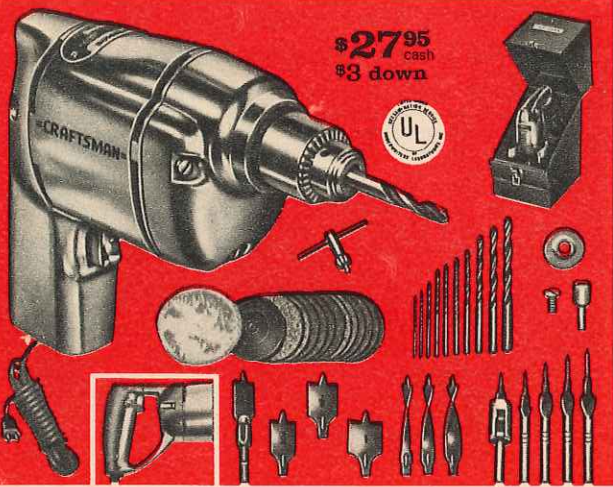

\$27.95
cash
\$3 down

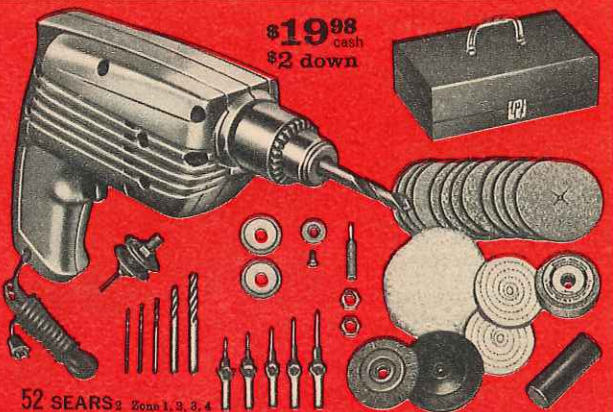

\$19.98
cash
\$2 down

Buy on Easy Terms . . . see inside back cover

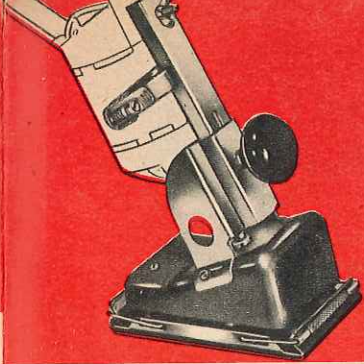

1

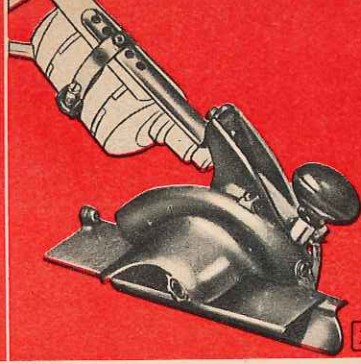

2

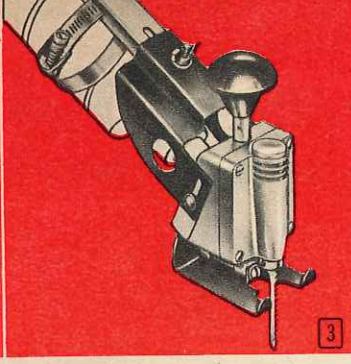

3

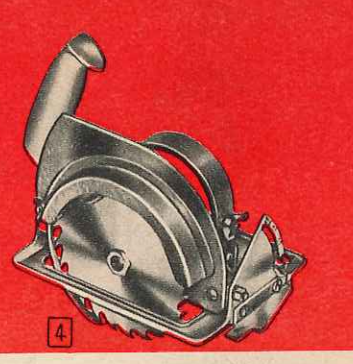

4

Change Accessories . . your drill becomes a new power tool

1 CRAFTSMAN Sanding Attachment. Designed to fit almost any $\frac{1}{4}$ -inch electric drill. Perfect for the home owner or craftsman who wants to get the most out of his $\frac{1}{4}$ -in. electric drill—for the man who wants a power sander without the extra expense of another tool. Suitable for most light sanding jobs—for furniture, woodwork, polishing, etc. 2 to 1 ratio for smoothness of operation; rubber mounted base for even sanding. Sturdy die-cast housing.
9 M 2719—Shpg. wt. 4 lbs. 13 oz. \$9.98

2 CRAFTSMAN Planer Attachment. Ideal for light planing—makes smooth, straight cut $1\frac{1}{16}$ inches wide; adjusts to $\frac{1}{8}$ -inch maximum depth of cut. Fence adjusts to full 15 degrees; takes care of tight doors, windows, screens, etc. Smooths rough surfaces. Rugged and dependable. 1-inch (outside diameter) steel 6-flute cutter.
9 M 2632—Shpg. wt. 4 lbs. 8 oz. \$11.98
9 M 2632S—Replacement Cutter. For 9M2632 Planer Attachment above. Shipping weight 3 ounces. 2.19

3 CRAFTSMAN Sabre Saw Attachment. Cut intricate patterns in plywood—make blind cuts in wood without pilot holes—saw through planks effortlessly and surely—simply by utilizing the power of your $\frac{1}{4}$ -inch drill. Sabre saw attachment has tilting base for angle cuts to 45°. Built-in saw dust blower cleans line of cut. Attachment fits any $\frac{1}{4}$ -inch drill. Sturdy die-cast housing gives rugged protection. Top handle for easy holding and guiding.
9 M 1852—Shpg. wt. 3 lbs. 10 oz. \$10.98

4 CRAFTSMAN Saw Attachment. With ball-bearing spindle. For most $\frac{1}{4}$ -inch electric drills, especially drills like 9M790 and 9M791 shown on page 50. Base tilts 45°. $5\frac{1}{2}$ -inch diameter blade; cuts 2x4's at 90°.
9 M 2626—Shpg. wt. 4 lbs. 5 oz. \$10.98
Kromedge Chisel-Tooth Combination Blade. Please state blade size wanted.
9 M 3240—For above, $5\frac{1}{2}$ x $\frac{1}{2}$ -in. round center hole. Shpg. wt. 10 oz. \$2.29
9 M 3240—For former No. 2606. $4\frac{1}{2}$ x $\frac{3}{8}$ -in. center hole. Wt. 5 oz. 1.49



5



6

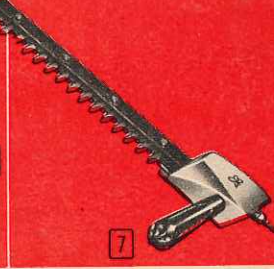

7



8

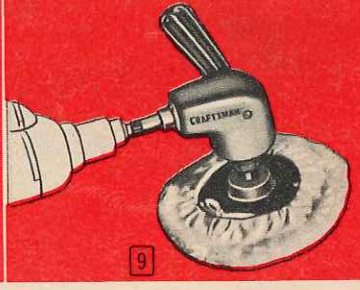

9

5 Power Sewer Auger. Fits directly onto your $\frac{1}{4}$ or $\frac{3}{8}$ -inch electric drill. Avoids costly clogged sewers. 25-foot auger cleans sinks, bathtubs, toilet bowls, outside sewers of sand, paper, grease, etc. Made of spring steel; revolving spear point digs through stoppages. Flexible; for short, sharp bends. 25 feet long; $\frac{1}{4}$ in. round. Wt. 15 lbs. 9 M 6716— $\frac{1}{4}$ -in. round shank. Shipping weight 3 ounces. \$19.98

6 CRAFTSMAN 5-in. Rotary Sander Kit. For $\frac{1}{4}$, $\frac{1}{2}$ -in. electric drills.
9 M 2847—Shpg. wt. 12 oz. \$2.98
9 M 28473—Activator Cement. Holds discs on 9M2847. Shpg. wt. 5 oz. 59c
CRAFTSMAN Sander-Polisher Kit. Adapter, lamb's wool bonnet.
Catalog Number Size of discs No. of discs Shpg. wt. Each
9M2827 4 in. 1 12 oz. 98c
9M2841 5 in. 3 1 lb. \$1.49
9M28416 6 in. 3 1 lb. 1.98

7 CRAFTSMAN Electric Drill Hedge Trimmer Attachment. Fits any $\frac{1}{4}$ -inch drill. Sickle-type chrome-alloy steel blade cuts in both directions. $12\frac{3}{4}$ -inch blade with $10\frac{1}{2}$ -inch cutting edge. With accessory handle . . fits on either side of housing for left or right hand use, depending on your needs. Shipping weight 3 pounds. 9 M 2627 \$10.98

8 CRAFTSMAN Roto-Saw Attachment. Converts $\frac{1}{4}$ -in. electric drill, drill press to power saw, filer. Wrench, adapter, 3 blades.
9 M 2508—Shpg. wt. 2 lbs. \$9.98
Extra Blades. State fine, medium, coarse.
9 M 2507—Fine tooth edge, 24 teeth. Shpg. wt. 3 oz. Set of 3 49c
Medium tooth edge, 14 teeth. Shipping weight 3 ounces. Set of 3 49c
Coarse tooth edge, 7 teeth. Shipping weight 4 ounces. Set of 2 49c

9 CRAFTSMAN 10-piece Angle-drive Buffer-Sander-Polisher. Adds 2 drill speeds. Angle head, speed adapter, polishing bonnet, rubber plate, six 5-in. sanding discs. Please state blade size wanted.
9 M 2629—Wt. 2 lbs. 2 oz. \$7.49
5-inch Abrasive Discs. Fit $4\frac{1}{4}$, 5 inch plates. 3 medium, 3 fine grit.
9 M 2543—Wt. 4 oz. Pkg. of 6. 39c
Open Coat Grit. For heavy stock.
9 M 2542—Wt. 2 oz. Pkg. of 3. 39c

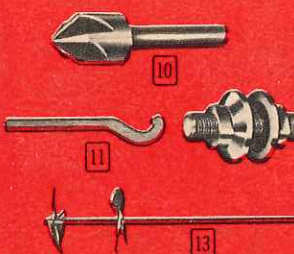

10



11

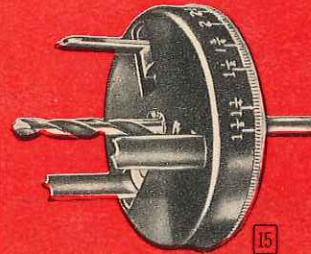

12

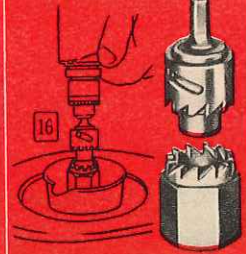

13



14

10 CRAFTSMAN Countersink Bit. Made of high speed steel. For countersinking in metal or wood. Can be used in electric drill, drill press or hand drill. 5 flutes; 82° head. $\frac{1}{2}$ -inch size.
9 M 6716— $\frac{1}{4}$ -in. round shank. Shipping weight 3 ounces. \$1.49

11 CRAFTSMAN Chuck Wrench. To remove $\frac{1}{4}$ -inch chucks.
9 M 20515—Shpg. wt. 3 oz. 19c

12 CRAFTSMAN Arbor for Electric Drills. Steel; $\frac{1}{4}$ -in. shank; spindle $\frac{1}{2}$ -in.x20 thread.
9 M 2594—Shpg. wt. 6 oz. 89c

13 CRAFTSMAN "Twin-action" Paint Mixer. For $\frac{1}{2}$, $\frac{3}{8}$ -inch electric drill.
9 M 25683—Shpg. wt. 7 oz. 59c

14 CRAFTSMAN Angle Head Attachment. Will fit any $\frac{1}{4}$ -inch electric hand drill with $\frac{3}{8}$ -in.x24 spindle. For close-quarter work.
9 M 1850—Wt. 1 lb. 10 oz. \$4.98

15 Hole Saw Attachment. Rotating blades cut circular hole in wood around drill hole. You find center with drill point, start drilling hole. Saw blades follow guide of drill, bore out hole. Dial lets you set diameter of hole from $1\frac{1}{2}$ to 2 $\frac{1}{2}$ inches. Depth of cut up to $1\frac{1}{16}$ inches. Shipping weight 1 lb. 8 oz.
9 M 2566 \$4.98

Extra Hole Saw Blades. Three in set; all blades in set same size. Used as a unit. Please be sure to state size. Shipping weight 3 ounces.
Size Long Medium Short
Depth cut
(inches) } $1\frac{1}{16}$ 1 $\frac{1}{8}$ $\frac{9}{16}$
9 M 25665 Set of 3 49c

16 Engine-Starter Drill Attachment. This handy attachment for your electric drill eliminates back-breaking rope pulling to start your balky small gasoline engines. Nut fits on end of crankshaft, drill attachment fits nut. To turn engine over, simply engage electric drill. Attachment on drill disengages from nut when engine starts. For best results use with electric drills of 1/5 HP or more, with $\frac{1}{4}$ or $\frac{3}{8}$ -inch capacity. Shipping weight 10 ounces. \$2.19

Cat. No.	Nut Size	Fits these engines
9 M 26032	$\frac{1}{16}$ -inch by 20 thread RH	CRAFTSMAN, Clinton, Iason, Power Products, Pioneer Champion Outboard
9 M 2603	$\frac{1}{2}$ -inch by 20RH	Bowles, Propulsion, Mercury
9 M 26034	$\frac{1}{2}$ -inch by 20LH	Briggs and Stratton

17 Reversible Screwdriver and Speed Reducer Kit. Reversible screwdriver, nut-runner, drill, tapper, etc. Includes 1 speed reducer with key (9M25656 below), one $\frac{1}{2}$ -inch chuck with key (9M2142, page 42), 1 square drive adapter, 2 arbors, nine $\frac{1}{4}$ -inch drive sockets (two 8-point; $\frac{1}{4}$, $\frac{5}{16}$ inch, seven 6-point: $\frac{1}{32}$, $\frac{1}{16}$, $\frac{3}{32}$, $\frac{1}{8}$, $\frac{1}{4}$, $\frac{3}{8}$, $\frac{1}{2}$); 3 Phillips bits, sizes 1, 2, 3; two standard screwdriver bits, 1 screw finding bit. Comes in 8x4 $\frac{1}{2}$ x3 $\frac{1}{2}$ -inch steel carrying case. Guaranteed 1 year.
9 M 25654—Shipping weight 6 lbs. 2 oz. \$22.95

CRAFTSMAN Reversible Screwdriver and Speed Reducer Attachment. Fits any $\frac{1}{4}$, $\frac{3}{8}$ or $\frac{1}{2}$ in. electric drill, drill press . . . increases torque 6 or 7 times! With medium-size screwdriver bit; No. 2 Phillips-type bit; $\frac{1}{4}$ -inch square drive adapter; wrench pin.
9 M 25656—With instructions. Shpg. wt. 1 lb. 15 oz. \$14.98
9 M 4189—3 Phillips-type Replacement Bits for above. Sizes 1, 2, 3. Shipping weight 6 oz. 1.89
9 M 4199—3 Regular Replacement Screwdriver Bits (small, medium, large) for 9M25656 (above) and 9M25952 (below). Shipping weight 6 ounces. 1.89

CRAFTSMAN Screwdriver Attachment. For $\frac{1}{4}$, $\frac{3}{8}$ in. electric drills. 1 standard, 1 No. 2 Phillips-type bit.
9 M 25952—Shipping weight 1 pound 3 ounces. \$4.98

Build your order to \$20 or more and buy on Easy Terms. See inside back cover

Make home repairs easier, hobbies more fun . . .
put these hardworking tools in your shop

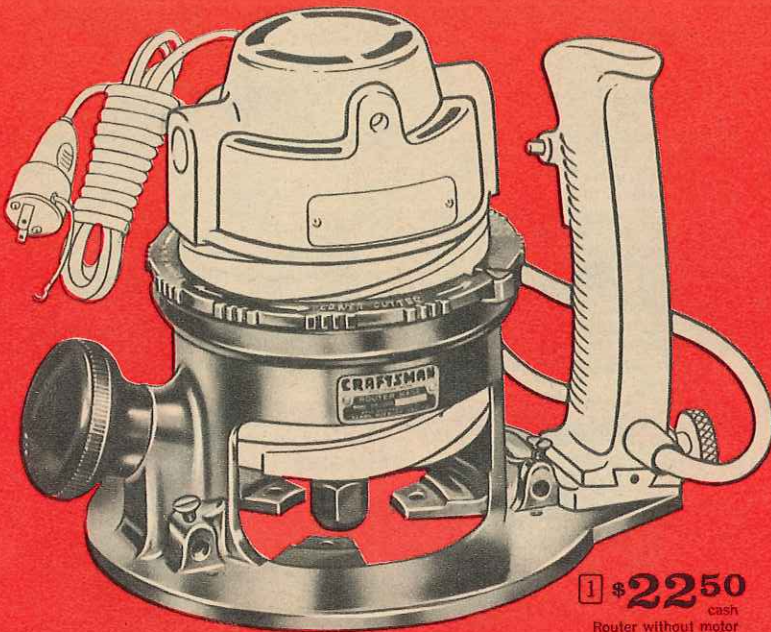

1 \$22.50
cash
Router without motor
\$2.50 down

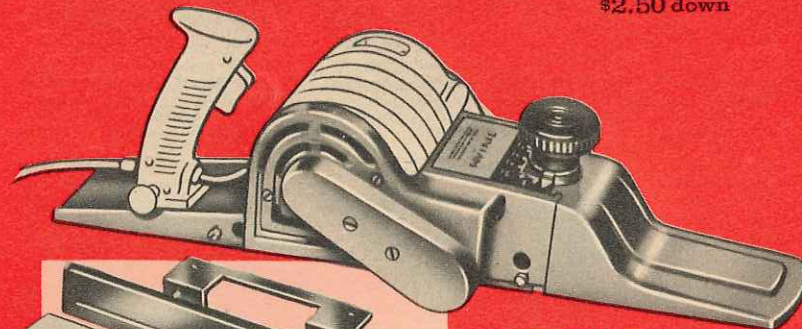

2 \$59.95
cash
Jointer-Planer
without motor
\$5 down

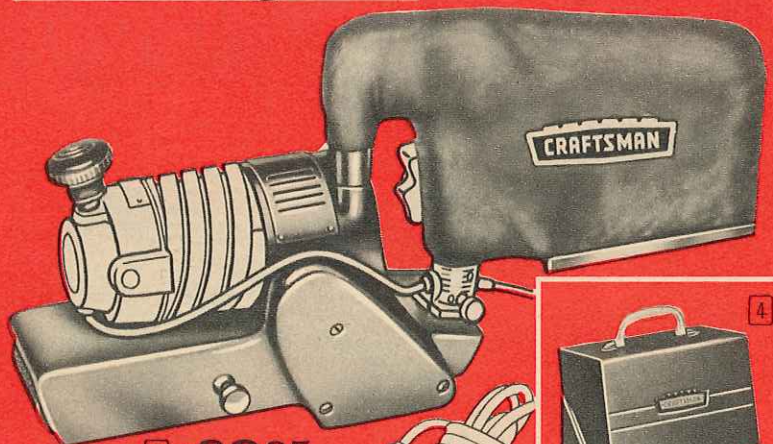
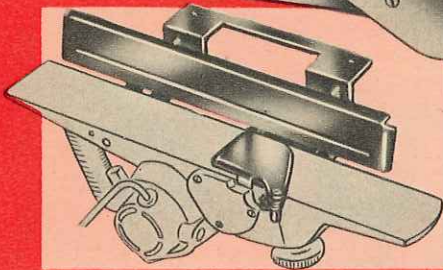

3 \$69.95
cash
Belt Sander
without motor
\$5 down



4

SEARS GUARANTEE

We will repair without charge or replace with a current model of equal quality any CRAFTSMAN electric motor, router, planer, sander or shaper on these two pages found defective in materials or workmanship if returned to us within one year of purchase.

CRAFTSMAN Power Router

1 A valuable tool for home repairmen, hobbyists, carpenters, builders, and woodworkers. Makes groovings for shelves, dadoses, mortises, rabbets, dovetails, and tenons. Also cuts a wide variety of decorative designs. Motor develops 1½ HP, gives bits top speed for fast, smooth and accurate cutting.

Hardened steel collet-type chuck takes ¼-inch shank bits (not included. See bits on page 29). Light, sturdy aluminum body on nickel-plated steel sub-base. Depth of cut adjusts 1¾ inches. Depth of cut indicator calibrated in 1/64ths. With wrenches and instructions.

9 M 25056—Router Base without motor. Shipping wt. 3 lbs. 3 oz. \$22.50

9 M 2501—Router with Interchangeable Motor and Edge Guide (9M25153 on page 55). Shipping weight 13 pounds. \$49.95

CRAFTSMAN Jointer-Planer

2 Trim doors, windows or other objects requiring close fit. Light enough to carry for planing heavier work pieces. Also turns upside down as stationary jointer-planer for easy use with lighter objects. Width of cut 3 inches, depth of cut ½ inch by 1/64th inch micrometer adjustments. Ball-bearing arbor, 2 removable blades. Slip clutch protects motor from overloads. Fence adjusts 0° to 45° either side. Painted aluminum body. Length 20 inches.

9 M 25015—Jointer-Planer without motor. Consists of planer, jointer attachment (stand and blade guard). Shipping weight 11 pounds. \$59.95

99 M 25017C—Jointer-Planer as above and with Interchangeable Motor. Shipping weight 19 pounds. \$89.50

CRAFTSMAN Belt Sander

3 Perfect tool for your bigger sanding jobs. Big 3x25-in. belt. No sweep-up after using this sander. Fan pulls in all sawdust and stores it in detachable bag. Drum bearings protected with dust seals. Smooth-running ball-bearing worm gear drive. Aluminum body. With three 3x25-inch sanding belts; fine, medium and coarse.

9 M 25055—Sander Attachment without motor. Shpg. wt. 14 lbs. \$69.95

99 M 25172K—Sander complete with motor 9M25055 below. Wt. 22 lbs. 99.50

Extra Belts. State grit wanted. Shipping weight 5 ounces each.

9 M 2232—Extra fine, fine, medium, coarse. Each 39c

9 M 2232—Open coat. 59c

4 Steel Carrying Case. For router (1) described above. Also equipped to hold the router edge guide. Has space for extra bits wrenches and cord storage. Dimensions: 10¼x7¾x12¾ inches.

9 M 1487—Shipping weight 7 pounds 5 ounces. \$5.49

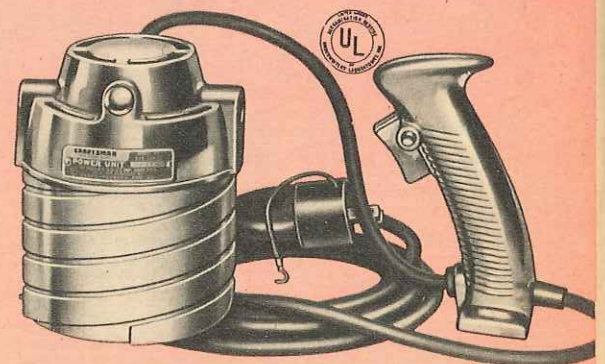

Interchangeable Motor \$29.95 \$3
cash down

This motor powers all the tools shown and described on this page. Buy any tool above with its own motor or buy more than one tool and save by powering them with only one motor. Develops 1½ HP. 110-120-volts, 60-cycle AC-DC. Splined shaft assures no-slip power. Grease-sealed ball bearings. Aluminum handle. 10-ft. 3-wire cord, plug, adapter, ground lead. Underwriters' Laboratories approved.

9 M 2505—Motor and Handle Unit only. Shpg. wt. 7 lbs. 13 oz. . \$29.95

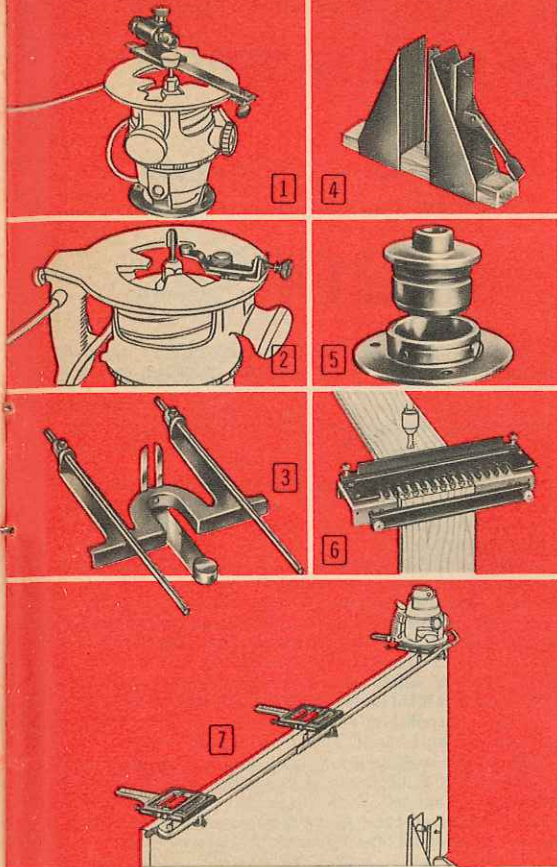

Accessories for Portable Power Routers

- 1 **Sharpening Attachment.** For shaper and router bits. Fits routers 9M2501 (page 54) and 9M25589 at right. To use, insert $\frac{1}{4}$ -inch shank bits into holder and mount attachment on router base. Shaper cutters (with $\frac{5}{16}$ -in. bore) use arbor supplied with shaper table below. Vertical, horizontal and angular adjustments. 9 M 25159—Shipping weight 2 pounds 7 ounces. \$12.98
- 2 **Formica-trimming Attachment.** Bevels, cuts contours, trims hard Formica and plastics. Makes cutting out sink top openings and similar jobs simple and easy. $\frac{1}{4}$ -inch shank tungsten carbide cutter bit included. Adjustable width and depth of cut. Fits only routers 9 M 2501 (page 54) and 9 M 25589 at right. 9 M 25473—Shipping weight 9 ounces. \$4.98
9 M 2541—Replacement Cutter Bit. For straight and bevel cutting of Formica. Carbide-tipped; fast-cutting, long-lasting. Shipping weight 2 ounces. \$4.49
- 3 **Router Edge Guide.** Fits router 9M2501 (page 54). Contour finger for routing various shapes. Attaches to either side. With 2 set screws. 9 M 25153—Shipping weight 1 pound 11 ounces. \$4.98
- 4 **Sash and Door Holder.** Holds screens, windows and doors securely. Use when planing, setting hinges or installing locks. Handy foot lever operates lock. 9 M 2567—Shipping weight 12 pounds. \$5.98
- 5 **Template Guide Bushings.** With holder, 3 template guides for: $\frac{3}{8}$ -in. O.D. for hinge mortising, stair treads; $\frac{1}{2}$ -in. O.D. for inlay work, dovetailing. 9 M 25059—Fits only Router on page 54. Shpg. wt. 1 lb. 2 oz. \$5.98
- 6 **Dovetail Template.** Fits power routers 9M25589 above and 9M2501 page 54. Both pieces of wood cut at same time . . . makes perfect fit. Clamps work pieces at right angle, router rides in slotted plastic comb. Perfect spacing and depth of cut for either flush or rabbeted $\frac{1}{2}$ -inch dovetail joints. Takes stock up to 12 inches wide . . . $\frac{5}{16}$ to $1\frac{1}{2}$ inches thick. For template guide bushings (not included) see (5) above. 9 M 2572—Shipping weight 9 pounds 10 ounces. \$19.98
- 7 **3-section Butt Hinge Template.** Makes hinge and lock face mortising easy and accurate. Eliminates guesswork. Guides router without change of setting when mortising both door and jamb. For either square or round-cornered $1\frac{1}{2}$ to 5-inch hinges. Use on doors up to 8 feet high, $\frac{3}{4}$ to $2\frac{1}{2}$ inches thick. Fits routers 9M2501 (page 54), 9M25589 (above) and other routers with $\frac{5}{8}$ -inch guide bushings.
99 M 2574C—For 2 or 3-hinge doors. Shipping weight 15 pounds. \$26.95
9 M 25742—Single-section Butt Hinge Template. One section of 99M2574C above. Shpg. wt. 3 lbs. 8 oz. \$9.98



\$19.98
cash
\$2.00 down

Portable Power Router for home workshop

- Dovetails close-fitting joints for bookcases and furniture drawers
- Finishes table and counter-top edges, makes many decorative cuts

Compare our price with all other router prices. Lightweight, easy to operate. Makes decorative cuts and freehand carving simple. Exceptionally fine for home workshop because it gives you speed, accuracy and handling ease at so low a cost.

Motor develops $\frac{3}{8}$ horsepower for smooth, chatter-free routing. Grooves, mortises, rabbets, dovetails the fast, easy way; gives you professional-looking results. Turns out more work in minutes than hand tools accomplish in hours.

Depend on this router to do your cabinet work, beading and inlay work. Motor ventilating fan blows chips away from line of work. Build your own custom furniture, bookcases and lawn markers; with your imagination there's no limit to the number of uses you'll find for this router.

Attach guide bushings (1 set included) to make dovetail joints or set door or cabinet hinges (see router accessories at left). Ball-bearing-mounted chuck (hardened steel collet-type) takes bits with $\frac{1}{4}$ -inch diameter shanks. Rugged, lightweight aluminum housing. Height adjusts $1\frac{1}{4}$ inches. For 110-120-volts, 60-cycle AC. Listed by Underwriters' Laboratories. *Guaranteed 90 days against defects in materials and workmanship.*

Comes completely equipped with edge guide. 2 chuck wrenches for easy bit changes. *For router bits, see page 29. See inside back cover for easy terms.*

9 M 25589—Router with Guide Bushings. Shipping weight 5 pounds 10 ounces. \$19.98
9 M 2576—Replacement Guide Bushings for above router. Shipping weight 10 ounces. \$2.19

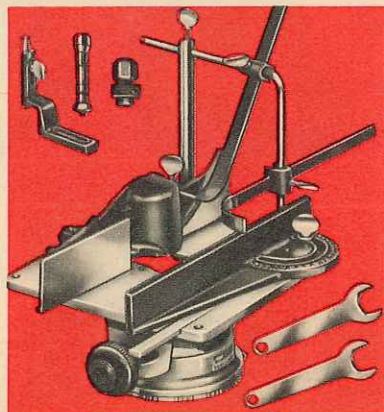

CRAFTSMAN
REGISTERED

Shaper Table Attachment

Without motor, handle unit **\$44.95** \$4.50 cash down

Make your own moldings, trim and picture frames. Cut your favorite designs with one or a combination of cutter bits listed page 29 (bits not included with shaper attachment). Powered by interchangeable motor (9M2505 page 54). Made of cast aluminum with tilting base. Micrometer setting adjusts height of cut up to maximum of $1\frac{1}{4}$ inches. Includes movable fence, detachable guard, spindle and collet chuck, miter gauge, contour guide and hold-down fingers. *Guaranteed one year against defects in materials and workmanship.*

99 M 25158C—Shaper Attachment with motor and handle unit. Shipping weight 19 pounds. \$5.00 down. Cash \$74.50
99 M 25157C—Shaper Attachment without motor, handle unit. Shipping weight 11 pounds. \$44.95

FOR SEARS EASY TERMS see inside back cover

CRAFTSMAN Heavy-duty Reciprocating Sander-Polisher

REG. U. S. PAT. OFF.



37 square-inch sanding pad makes quick work of big jobs

Without case **\$29.95** **\$3.00**
cash down

High-speed sanding action (14,400 strokes per minute) gives your cabinet work a satin smooth finish quickly . . . makes it ready for stain or varnish without extra preparation! We believe you can't match its ability to produce a fine finish. You'll achieve a smooth, scratch-free finish on wood even against the grain. Industrially rated to help professional or home craftsmen turn out top-notch work.

Sands twice as fast as medium-duty sander below! 37 square-inch sanding pad measures $4\frac{1}{2} \times 8\frac{1}{4}$ inches . . . uses $\frac{1}{2}$ sheet of standard 9x11-inch sandpaper or extra-durable Karbo-Grit sheets listed below.

Double-arc action speeds sanding jobs. No motor maintenance . . . no bearings or gears to oil . . . no belts or brushes to wear out. Designed for years of rugged use.

Balanced, rubber-cushioned handle is nearly vibration-free . . . you can sand all day long without fatigue. Handle does not conduct heat . . . remains cool to the touch.

Reciprocating action of sander does not blow or scatter dust . . . makes it ideal for home workshops, cabinet shops, etc. Lightweight polished aluminum housing makes vertical and overhead work easier. Finger-tip "on-off" switch.

With lamb's wool polishing pad, 8-foot three-wire cord, plug adapter and 12 sheets of aluminum oxide sandpaper. *Guaranteed for one full year.*

110-120-volt, 60-cycle AC. *UL approved* to meet requirements for Industrial Standards.

- 9 M 768—Sander-Polisher. Shpg. wt. 7 lbs. 13 oz. \$29.95
- 99 M 14996C—Sander-Polisher with steel case. Shpg. wt. 15 lbs. 33.95
- 9 M 14821—Steel Carrying Case. Use also for orbital sander. (9 M 2599) shown on facing page. Shpg. wt. 6 lbs. 12 oz. 5.49
- 9 M 2740—Aluminum Oxide Sanding Sheets. $4\frac{1}{2} \times 11$ inches. 12 sheets in each package. *State grit:* fine, medium, coarse, extra coarse. Shipping weight 11 ounces. Package 49c
- 9 M 2537—Lamb's Wool Polishing Pad. $4\frac{1}{2} \times 11$ inches. Shipping weight 3 ounces. 89c
- 9 M 3012—Karbo-Grit Sheets. $4\frac{1}{2} \times 11$ inches. Sand twice as fast as sandpaper, last 40 times longer. *State grit:* fine, medium, coarse. Shipping weight 7 ounces. Each \$1.98

GUARANTEE If any CRAFTSMAN sander or sander-polisher shows defects in materials or workmanship, we will repair or replace it at no charge if returned to us within one year of the purchase date.

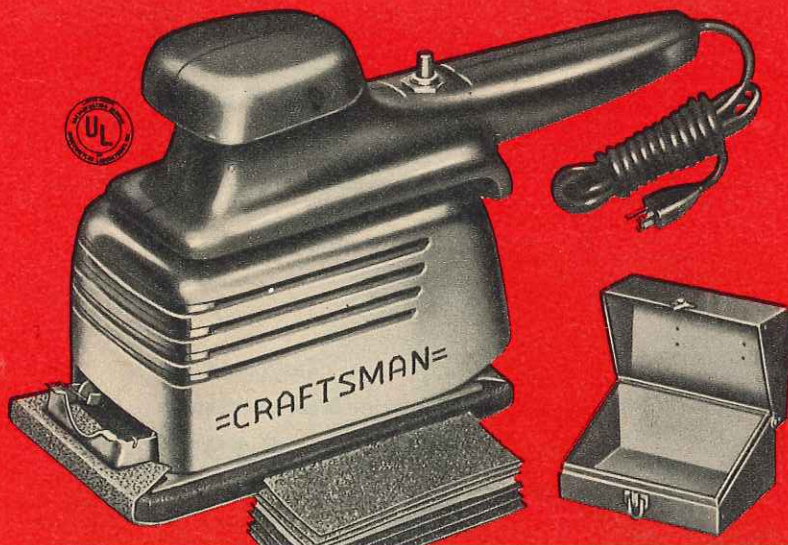

CRAFTSMAN Medium-duty Sander

18 sq.-in. sanding pad measures 3x6 inches. Fatigue-proof, vibration-free handle for effortless sanding. Fast double-arc sanding action does not blow or scatter dust. No bearings, gears to oil; no belts, brushes to wear out. Polished aluminum housing. On-off switch. NOT for removing paint, varnish, deep scratches. With 6-foot three-wire cord, plug adapter and six assorted grit aluminum oxide sanding sheets. 110-120-volt, 60-cycle AC.

Approved by Underwriters' Laboratories, Inc. (Industrial standards). Guaranteed one year.

- 9 M 765—Without case. Shpg. wt. 5 lbs. \$15.98
- 9 M 1498—With case. Shpg. wt. 7 lbs. 12 oz. 16.98
- 9 M 1494—Steel case only. Use also for light-duty sander at right. Shpg. wt. 2 lbs. 12 oz. \$2.19
- 9 M 2782—Lamb's Wool Polishing Pad. Wt. 2 oz. 55c
- 9 M 2746—Sanding Sheets. Pkg. of 18 sheets. *State grit:* fine, med., coarse. Shpg. wt. 5 oz. 39c
- 9 M 3004—Karbo-Grit Sheets. $2\frac{3}{4} \times 8$ in. *State grit:* fine, med., coarse. Shpg. wt. 5 oz. Each 98c

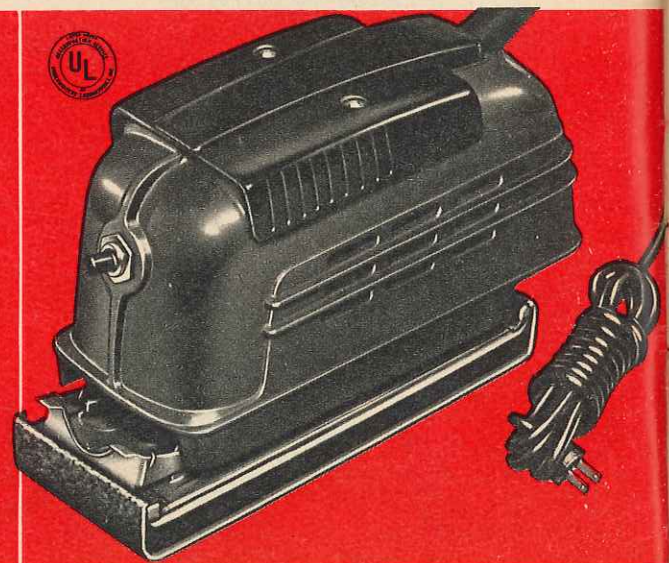

Light-duty Sander

For finish-sanding furniture . . . polishing waxed surfaces. Especially adapted to give light, soothing body massage . . . use with lamb's wool polishing pad listed at left. 18-square inch sanding pad measures 3x6 inches. No bearings, gears to oil; no belts, brushes to wear out. Enamel finish aluminum housing. On-off switch. NOT for removing paint, varnish, deep scratches. Includes 6-ft. two-wire cord, one sanding sheet. Uses sandpaper no coarser than No. 60. Order steel case, sanding sheets and Karbo-Grit sheets listed at left. 110-120-volt, 60-cycle AC. *UL approved. Guaranteed 90 days.*

- 9 M 2713—Shipping weight 4 pounds 11 ounces. \$9.98

CRAFTSMAN Motor-driven Orbital Sander

REG. U.S. PAT. OFF.

Powerful long-stroke sanding action
zips through the toughest jobs!

\$24.95 **\$2.50**
cash down

1 A perfect general-purpose sander for home workshops. Orbital motion of sanding pad gives greater stroke for rapid wood removal rate and more effective use of Karbo-Grit sheets (listed below) for dry wall sanding, removing paint, varnish, deep scratches and dents. Excellent for sanding old or unfinished furniture. Use with polishing pad (listed below) for waxing furniture, cabinets, rubbing down between finish coats of varnish, etc. Fast, deep-biting action speeds all sanding work. 25 $\frac{1}{2}$ sq. in. sanding pad measures 3 $\frac{3}{4}$ x 7 in.

Perfectly balanced, lightweight . . . you can sand either vertically or horizontally. 3-position auxiliary knob attaches to either side or front of housing for left or right hand sanding. This tool design lets you get into tight corners, close to walls, etc.

Powerful universal motor drives sanding pad at 3500 orbital strokes per minute. Convenient locking switch is built into the handle for better control. Die-cast aluminum alloy housing. For 110-120-volt, 25-60-cycle AC. With 4 fine, 4 medium, 4 coarse sanding sheets (3 $\frac{3}{4}$ x 7 in.); 6-foot 2-wire cord, plug. *UL approved.* Order steel carrying case (9 M 14821) from facing page. 9 M 2599—Guaranteed 1 year. Shpg. wt. 5 lbs. 6 oz. \$24.95

2 Karbo-Grit Sanding Sheets. Karbo-Grit sands twice as fast as sandpaper. Outlasts sandpaper more than 40 times . . . eliminates changing of worn-out sandpaper . . . won't tear or stretch. If it clogs, just lift sander off work—sanding motion sheds waste from face of sanding sheet. Made of crushed tungsten-carbide grits embedded in copper for diamond-like hardness, yet won't burn or score work. Wire brush or solvent removes gummy paint or varnish. Ideal for painted or unfinished wood, all types of wallboard, plaster, plastics or dry wall joints. 3 $\frac{3}{4}$ x 9-inch overall size. *State grit:* fine, medium or coarse. 9 M 3005—Shipping weight each 7 ounces. Each \$1.49

Aluminum Oxide Sandpaper. For above Sander. 12 sheets per package. *State grit:* fine, medium, coarse or extra coarse. 9 M 2513—Shipping weight 9 ounces. Per package 39c

Lamb's Wool Polishing Pad. For above Sander. 9 M 2530—Shipping weight 2 ounces. 69c

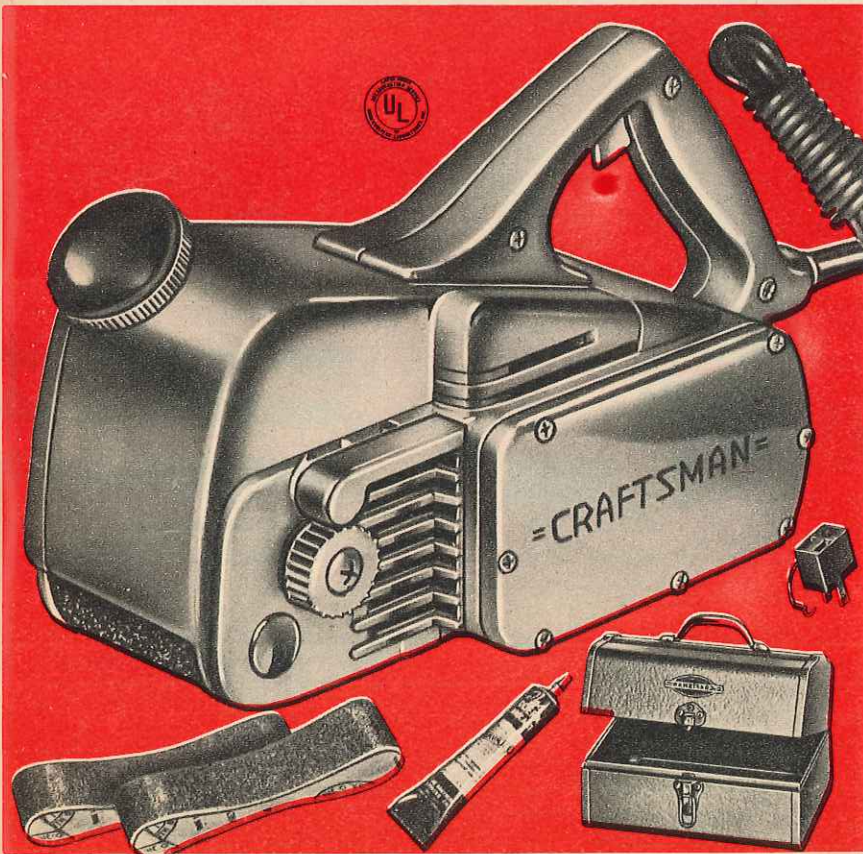
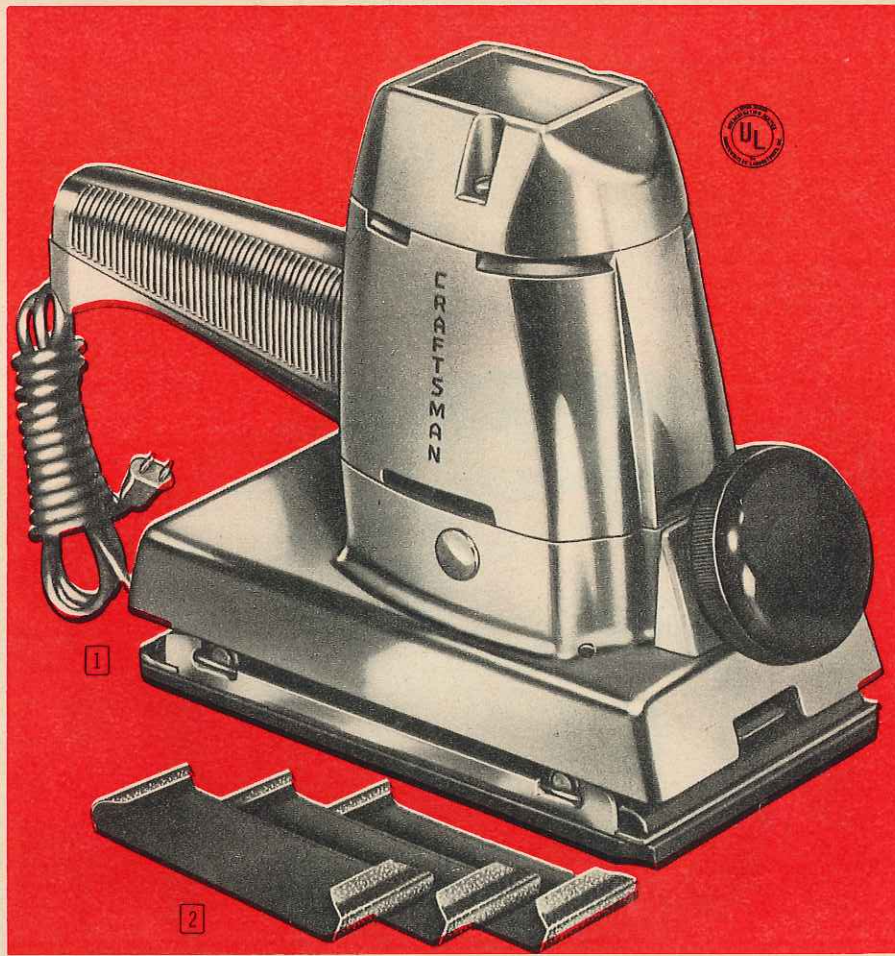

CRAFTSMAN Continuous-duty 3-drum Belt Sander

Sands large areas to a smooth, even finish . . .
1200-ft. per minute free belt speed

Without case **\$59.95** **\$5.00**
cash down

Designed for extensive flat surfaces. Comfortable to use, even over a long period of time . . . easy to control, handle is close to work. King-size 27x3-in. sanding belt is longer than belts used on conventional two-drum sanders. This means longer life and faster wood removal with fewer belt changes; operating expenses are cut and time is saved.

Three-drum design permits mounting motor in center, inside housing, for compactness, better balance, greater protection.

Lightweight aluminum housing. Quick-change belt release, tensioning control on outside of housing. Convenient belt-centering adjustment. All three drums have dust protected, self-lubricating bronze bearings. Built-in fan cools motor. Safety trigger switch. Direct spiral gear drive delivers smooth, even power—eliminates belt breakage problem. Husky, universal, ball-bearing motor (110-120-volt, 25 to 60 cycle AC-DC) develops $\frac{3}{4}$ HP; heat and abrasion resistant Formex insulation for long service life. *UL approved* (Industrial Standards).

Included are three aluminum oxide sanding belts (fine, medium and coarse), 10-ft. three-wire cord, plug adapter and lubricant. Overall height 8 in., length 27 in.

- 99 M 2556C—Without case. Shipping weight 16 pounds. \$59.95
- 99 M 2230K—With steel carrying case. Shpg. wt. 22 lbs. 64.95
- 9 M 2231—Replacement Belts, 27 x 3 inches. Aluminum oxide. *State grit choice:* 00 (extra fine), 0 (fine), 1 (medium), 2 (coarse). Shipping weight each 4 ounces. 49c
- Grit No. 4 (extra coarse, open coat). Shpg. wt. 4 oz. 75c
- 34 M 5882—25-foot Extension Cord, 14-gauge, three-wire Type "S". Shipping weight 5 pounds. \$5.98
- 9 M 2593—CRAFTSMAN Lubricant, 4-oz. tube. Shpg. wt. 9 oz. 69c

Order Belt Sander for only \$5 down See inside back cover for Special Easy Terms

When you buy a CRAFTSMAN Sabre Saw

REG. U.S. PAT. OFF.

Does the work of a rip, crosscut, coping, jig, scroll, band, keyhole and



Make fast, neat-looking cuts for electrical outlets, switch boxes, etc.



Build lawn markers, children's toys and other difficult patterns easily.

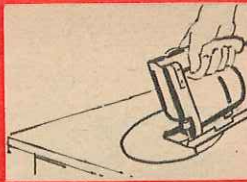

No need to drill holes for blind cuts—just tip saw and begin anywhere.

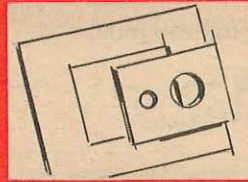

Do enclosed cutting in plywood sheets easily, quickly, in any pattern.

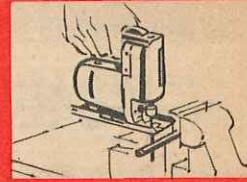

Cut metals—aluminum, brass, copper, steel—pipe conduit, etc.

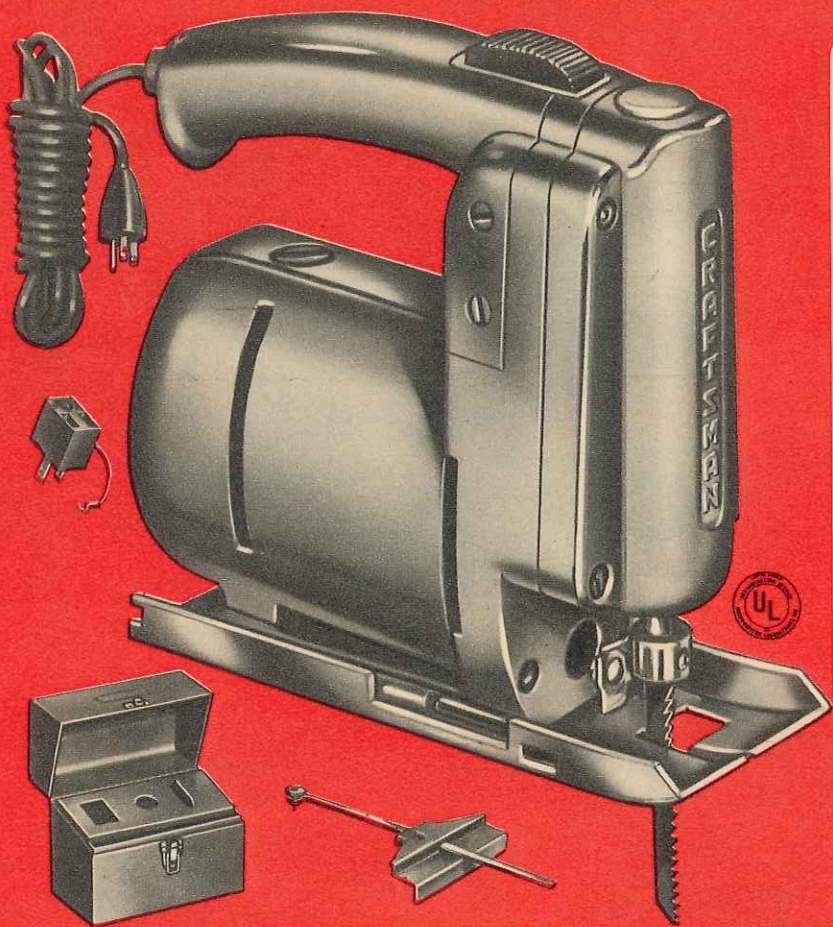

CRAFTSMAN Sabre Saw

REG. U.S. PAT. OFF.

Develops over 1/5 HP

Without case \$26⁹⁵ \$3
cash down

Here's an ideal all-purpose saw designed for heavy-duty service. Lightweight (only 4 1/2 pounds) for the home craftsman, yet powerful enough for industrial use. Plus-power universal motor with 1/2-in. stroke . . . enables you to cut a 2x4 with ease. Counter-balanced drive keeps vibration to a minimum for maximum cutting accuracy, less fatigue. Top handle permits positive, easy control . . . with fingertip slide switch for instant starting and stopping. Circle cutting and edge guide attachment included for additional versatility.

Polished aluminum alloy housing. Steel base plate tilts 45° to 90° for angle cuts. Fan blows sawdust from guide line. Ball and oil impregnated bearings. With 3 blades (7, 10, 32-tooth), 10-ft. 3-wire cord, plug adapter, wrench and wrench holder. For 110-120-volt, 25-60 cycle AC-DC. UL approved (Industrial Standards).

9 M 27946—Without case. Shpg. wt. 5 lbs. 15 oz. \$3.00 down. . . . Cash \$26.95

9 M 27947—With steel carrying case. (Same as 9 M 1488 below.)

Shipping weight 9 pounds 13 ounces. \$3.00 down. . . . Cash 29.95

One-piece Steel Carrying Case. For above Sabre Saw. 5 1/4 x 9 1/4 x 10 1/2 inches. With space for accessories, extra cord, etc.

9 M 1488—Shipping weight 4 pounds 10 ounces. . . . \$4.98

GUARANTEE

If any CRAFTSMAN Sabre Saw shows defects in materials or workmanship, we will repair or replace it at no charge if returned within one year of date of purchase



\$15⁹⁸

Low-priced Sabre Saw Over 1/8 HP

A medium-duty saw for the home workshop. Guaranteed 90 days. Cuts plywood, 2x4's, etc. Plus-power universal motor delivers 3000 half-inch strokes per minute. Built-in blower clears sawdust from line of cut. No drilling needed . . . makes its own starting hole. On-off switch. Precision-sleeve bearings; steel base plate. UL approved. For 110-120 volt, 25-60 cycle AC. With 3 blades, 6-ft. 2-wire cord.

9 M 2775—Shipping weight 4 pounds 11 ounces. . . \$15.98

58 SEARS Zone 1, 2, 3 & 4

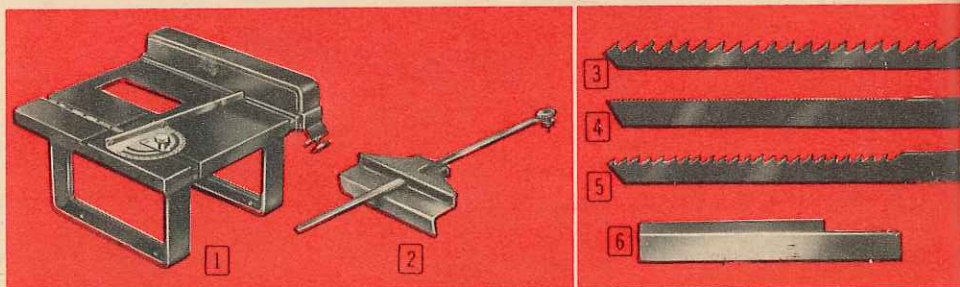

Attachments and Extra Blades for your Sabre Saw

1 Steel Table Top. Converts any saw on these 2 pages to a jig saw. Rip fence, miter gauge 2 miter grooves, 2 points for circles and clamps. 99 M 17412C—Wt. 13 lbs. . . \$9.98

2 Circle Cutting and Edge Guide Attachment. Fits all sabre saws on these 2 pages; gives you professional results when cutting intricate designs. 9 M 27945—Wt. 13 oz. . . \$1.98

Extra Blades. Choice of 3 sizes. Size 1 (7 teeth per inch) for soft woods, ripping; Size 2 (10 teeth per inch) for plywood, wallboard, hard woods, crosscutting; Size 3 (32 teeth per inch) for brass, aluminum, steel rods and sheets. Shipping weight, package of two, 2 ounces.

3 9 M 2871—For 9 M 27986 on facing page. 3 1/2 in. long. State size 1 or 2. . . Pkg. 49c

4 9 M 2870—For 9 M 27946, 9 M 27986 and 9 M 2775. 3 in. long. Size 3 only. . Pkg. 69c

5 9 M 2861—For 9 M 2775 and 9 M 27946. 3 in. long. State size 1 or 2. . . . Pkg. 49c

Extra-long Blade. For 9 M 27986 on opposite page. 6 in. long. 7 teeth per inch. Cuts larger size lumber (4-inch depth), small logs, tree limbs, etc. 9 M 2875—Shipping weight 2 ounces. . . . Each 69c

6 Knife-edge Blade. Cuts rubber, leather, cardboard displays, etc. 9 M 2873—For all 3 Sabre Saws. Shpg. wt. package of two, 2 oz. . . . Package 49c

..you get EIGHT different saws in ONE

hack saw..Cuts wood, plastics, plywood, wallboard, leather, metals, etc.

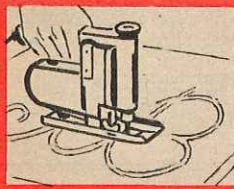

Cut most any material—Masonite, files, Formica, wallboard, plastics, wood, etc.

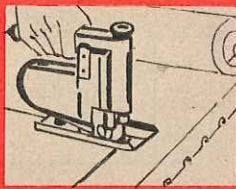

Cut cardboard displays, rubber, leather, etc., with knife blade (sold separately).

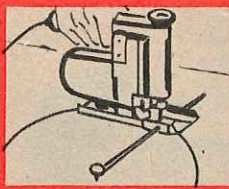

Cut intricate curves, perfect circles easily and quickly with circle gauge.

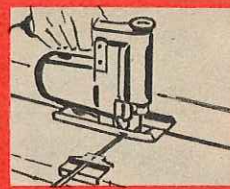

Cut edges and straight lines quickly and accurately with the edge guide.

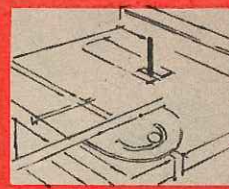

Use it as a jig saw with Steel Table Top (sold on the opposite page).



Without Case **\$41.95** cash \$4.50 down

CRAFTSMAN Professional Sabre Saw

REG. U. S. PAT. OFF.

Develops Over 1/2 HP . . Heavy-duty industrial quality
Full 1-inch stroke for faster cutting and greater capacity

This superb saw is specially designed for heavy-duty continuous service under the most exacting conditions. Ideal for skilled tradesmen or for home CRAFTSMEN who demand the very best in tools. A great time saver in electrical, plumbing and heating installations. Weighs only 6 1/2 pounds for easy handling.

Cuts up to 2 1/2-inch depth with blades supplied (4-in. depth when used with extra-long blade 9M2875 listed on opposite page—this makes it ideal for cutting small logs, limbs of trees, etc.). Counter-balanced drive assures minimum vibration. Top handle plus an auxiliary handle-knob for exceptionally good control. Instant-action safety trigger switch; lock button for continuous operation. Ball, needle and oil-impregnated bearings. Polished aluminum alloy housing. Steel base plate tilts 45 to 90 degrees. Fan clears guide line of sawdust. For 110-120 volt 25-60-cycle AC-DC. *Guaranteed one full year.*

Includes circle cutting and edge guide attachment for extra versatility—insures perfect circular cuts, allows easy and accurate pattern tracing, helps you saw edges and straight lines with precision and accuracy.

With 3 blades (7-tooth, 10-tooth and 32-tooth). 7-tooth blade for soft woods, ripping; 10-tooth blade for plywood, wallboard, hard woods, crosscutting; 32-tooth blade for brass, aluminum, conduit, BX cable, steel, etc.

Includes 10-foot 3-wire cord, plug, adapter, wrench with holder. Approved by Underwriters' Laboratories (Industrial Standards). *See page 58 for extra blades.*

9 M 27986—Without carrying case. Shipping weight 8 pounds 5 ounces. \$41.95

99 M 27987C—With 9 M 14821 below. Shipping weight 15 pounds. \$5.00 down. Cash 45.95

9 M 14821—1-piece Steel Case for saw above. Size 11 1/2 x 6 1/2 x 12 1/2 inches. Shipping weight 6 pounds 12 ounces. 5.49

BUY ON SEARS EASY TERMS . . see inside back cover for details

Contractor-type CRAFTSMAN Electric Hand Saws

REG. U. S. PAT. OFF.

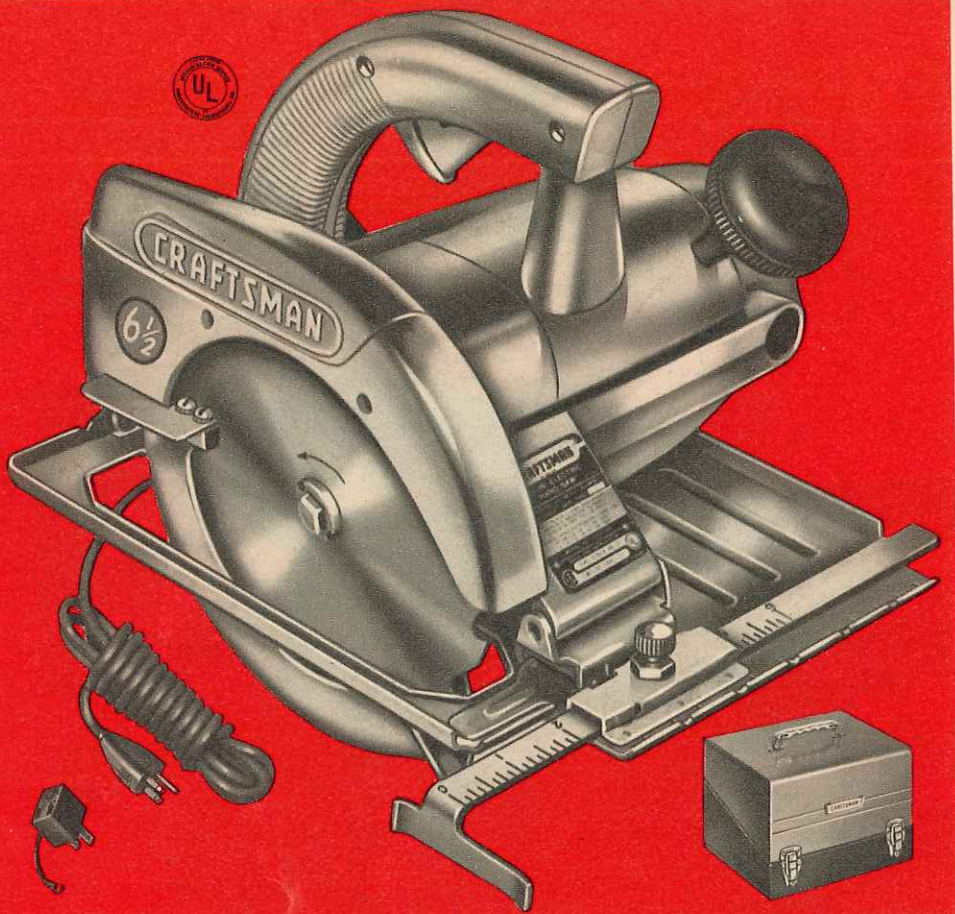

With Craftsman Electric

Powerful motor designed for tough cutting; direct gear drive. Saw has safety switch, protects motor against burnout from overload

Fast-cutting, rugged Kromedge blades that run true, stay sharp longer and outlast ordinary steel blades 3 to 5 times

6 1/2-inch Heavy-duty Model

as low as **\$44.95** cash

\$4.50 down

Use this husky hard worker for those tough sawing jobs. Fast, rugged motor turns blade at 3400 RPM under full load. Zips through a 2x4 to a depth of 1 3/4 inches with blade tilted at 45°. Maximum depth of cut 2 inches with blade at 90°. Graduated rip guide and base plate assure accurate cutting board widths when ripping. Precision ball and needle bearings are lubricated and sealed for normal motor life.

For 110-120-volts 25-60-cycle AC-DC. Underwriters' Laboratories approved (Industrial Standards). Guaranteed for one year. Kromedge chisel-tooth combination blade with 5/8-inch round center hole. 10-foot 3-wire cord, adapter, wrenches.

99M2796C—Saw without carrying case. Shpg. wt. 16 lbs. \$44.95

99 M 27967K—Saw with steel carrying case described below. Shipping weight 27 pounds. \$51.50

Steel Carrying Case. Holds any electric hand saw on this page or opposite page. Base measures 13 1/2 x 11 1/8 inches. 9 3/4 inches high. Shpg. wt. 11 lbs.

9 M 1470—Two-tone brown and bronze finish. \$8.49

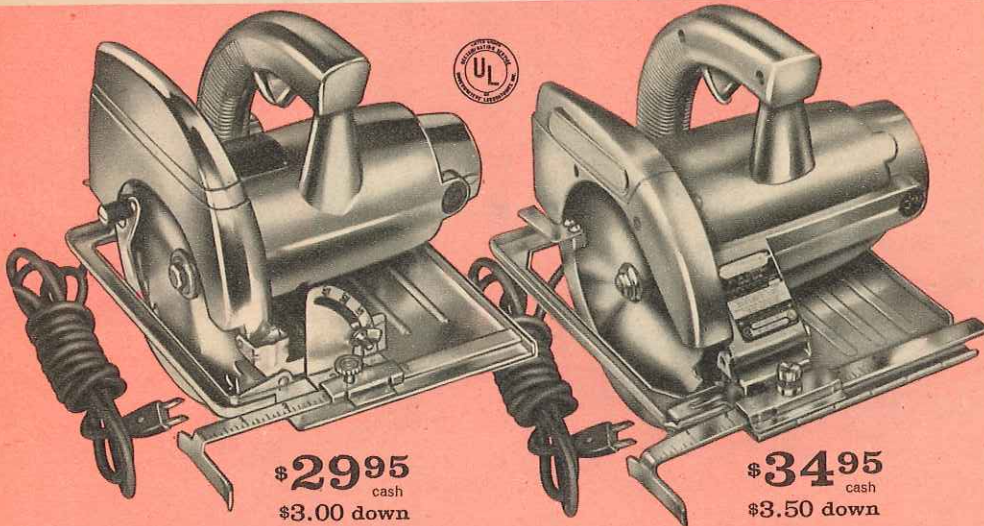

\$29.95 cash
\$3.00 down

\$34.95 cash
\$3.50 down

Budget-priced Electric Hand Saws

6 1/4-inch Model

Zips through 2x4 . . . cuts to depth of 1 3/4 in. with blade tilted at 45°; to depth of 2 1/4 in. with blade in normal position. Safety clutch resists burnout caused by overload. Universal motor develops 1 HP. Bronze bearings, lubricated for normal motor life. Aluminum-alloy housing, mottled tan finish. UL approved. Guaranteed 90 days. Chisel-tooth combination blade with 5/8-in. round center hole. Fine for intermittent duty. For 110-120-volts, 25-60-cycle AC-DC. With 8-foot cord and blade wrench.

99 M 2784C—Saw without steel carrying case. Shipping weight 10 pounds. \$29.95

99 M 27847K—Saw with steel carrying case. Shipping weight 21 pounds. \$36.50

6 1/2-inch Medium-duty Model

Perfect saw for your home workshop. 6 1/2-inch chisel-tooth combination blade with 5/8-inch round center hole. Converts to bench saw, chain saw or planer with accessories at right and on opposite page. Safety clutch resists burnout caused by overload. Cuts through 2x4 with blade tilted at 45°. Develops 1 1/2 HP. 110-120-volts, 25-60-cycle AC-DC. Precision bronze bearings. Aluminum-alloy housing, mottled bronze finish. UL approved. Guaranteed 90 days. 10-foot 3-wire cord, plug, adapter, wrenches.

99 M 2790C—Saw without steel carrying case. Shipping weight 16 pounds. \$34.95

99 M 27907K—Saw with steel carrying case. Shipping weight 27 pounds. \$41.50

GUARANTEE

If any CRAFTSMAN electric hand saw shows defects in materials or workmanship, we will repair or replace it at no charge if returned to us within one year of the date of purchase.

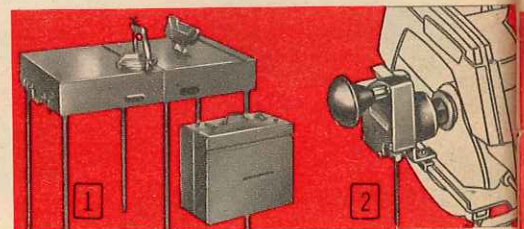

1 Steel Work Bench and Carrying Case. Opens to sturdy 20x33-inch work surface. 6 tubular steel legs (30 in. long). Bench folds suitcase-style with saw inside . . . carry your shop anywhere. Fits all saws on this and opposite page. Measures 10 1/2 x 16 1/2 x 20 inches folded. Saw, saw guard assembly, miter gauge and hold-down not included (see 9 M 21046 on page 61 for guard assembly).

99 M 1471K—Shipping weight 32 pounds. \$29.95

Rip Fence for portable bench above. Working face 20 1/4 inches long, 2 inches high.

9 M 2767—Shipping weight 5 pounds. \$9.50

2 Sabre Saw Attachment. Get the advantages of a sabre saw at only a fraction of its cost. Connect attachment to saw shaft end, easily converting your saw for making irregular cuts, scroll work and blind cuts such as holes for electric wiring. Fits saws in all our current catalogs. Blades cut leather, hard rubber, most plastics, woods and metals (see page 58 for sabre saw blades). With extra knob for easy, accurate control.

9 M 2848—Shipping weight 1 pound 12 ounces. . . . \$14.95

zip through your toughest sawing jobs

Hand Saws you get:

Reinforced aluminum-alloy housing (die-cast, lightweight). Has built-in sawdust blower and retractable blade guard

All-position handle directly over saw center of gravity . . . perfect balance and easy, accurate control at all times

7½-inch Industrial-type Model

\$64.95
cash

\$5 down
without case

A professional saw, a real workhorse. Powerful motor develops 2 HP . . . turns blade at 4200 RPM, under full load. Electro safety switch resists motor burnout, cuts out automatically if motor overloads. Push-button arbor lock makes blade changes quick, easy.

Maximum depth of cut 2¾ inches at 45°, cuts to 2¼-inch depth at 90°. Two-position knob for sure, easy handling. Self-storing, telescoping rip guide calibrated for easy reading. Precision ball and needle bearings (lubricated for normal motor life, sealed against dirt). 110-120-volts, 25-60-cycle AC. *U.L. approved.* With 7½-inch Kromedge chisel-tooth combination blade, ⅝-inch round center hole. 10-foot 3-wire cord, plug adapter and self storing wrench. *Guaranteed for one year* against defects in materials and workmanship.

99 M 2789C—Saw without carrying case. Shipping weight 17 pounds. \$64.95
99 M 27897K—Saw with Steel carrying case. Shipping weight 28 pounds. \$71.50

7½-inch Standard Model. Similar to above saw, but with precision bronze bearings—mechanical clutch, standard combination blade and rip guide. Without arbor lock. Mottled bronze finish. Develops 1¾ HP. For 110-120-volts, 25-60-cycle AC-DC. With 2-wire cord and plug. *Guaranteed for 90 days.*

99 M 2787C—Saw without carrying case. Shipping weight 17 pounds. \$5.00 down. Cash \$54.95
99 M 27877K—Saw with case. Wt. 28 lbs. 61.50

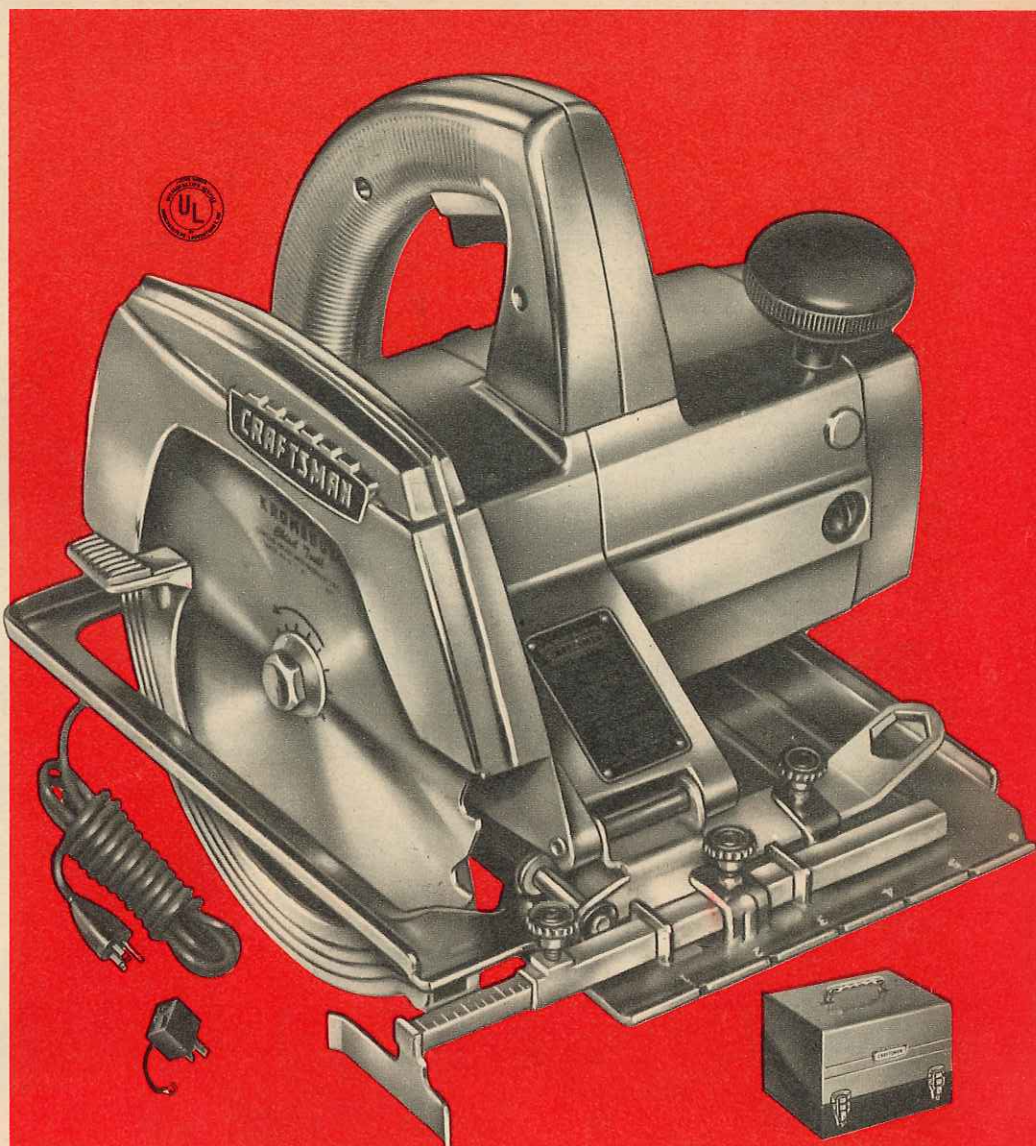

Make your saw perform more jobs with these accessories

1 Chain-saw Attachment. Converts only saws 99M2789C and 99M2787C listed above and 99M2796C, 99M2790C on opposite page to chain saws.

Slices through logs or lumber up to 10-inch diameter. Rips or crosscuts. Trims and prunes trees. Starts its own hole . . . cuts through walls, floors, or ceilings. Does a fine job in construction work, building and industrial maintenance.

Light weight, easily attached without removing saw blade guard. Saw not included with attachment. Wt. 3 lbs. 10 oz.
9 M 27905—\$3 down Cash \$29.95
9 M 27904—Extra Chain-saw Blade for above Shipping weight 10 ounces. \$12.50

2-3 CRAFTSMAN Planing Accessories. Add attachments below and saw becomes a portable or bench planer. Connect portable planer attachment 9M28454 to trim doors, windows, screens, other large objects. Turn over saw with planer, clamp on legs, blade guard of kit 9M28453 . . . makes bench-type jointer-planer. Instructions included.

2 Portable Planer Attachment. Use with saws above and on opposite page, or Black & Decker U-60, U-61, U-62, U-70; Skil 686, 687, 698; Porter Cable 125, A-6, 115, 507; Millers Falls 600, 610, 700; Stanley W-6; Mall 60; Port. Elec. 614. Die-cast aluminum body. 2-knife blade travels 3 times saw RPM. Fence adjusts to 45°. Cuts 2½ in. wide to ⅝-in. deep. 7½-in. shoe. Length 20¾ in. 2 pulleys; V-belt.
9 M 28454—Saw not included. Wt. 9 lbs. 13 oz. \$3 down. Cash \$29.95

3 Bench Planer Conversion Kit. For use with 9M28454 above to convert electric hand saw to bench-type jointer-planer. Removable planer blade guard, clamps. Steel legs with holes for mounting on work bench.
9 M 28453—Saw not included. Shipping weight 5 pounds. \$4.95

4 Portable Saw Guide. Use with any electric hand saw or portable sabre saw. For making fast, accurate angle cuts, compound miters (using bevel adjustment on saw), for laying out carpentry jobs, or use as regular protractor.

Easily adjusts and sets at any angle from 0 to 75 degrees to right or the left. Sturdy heavy-duty 16-gauge steel.

Make cuts with a minimum of work: place the saw shoe (saw rides on shoe) against the saw guide straight-edge. Keep shoe against guide and move it along edge. Shipping weight 3 pounds.
9 M 1719. \$3.69

5 Bench Saw Table Top. Converts electric hand saws above and opposite page to bench saws. 26x30-inch heavy-gauge steel top; hinged for fast conversion. 2 miter-gauge grooves. Rip guide. Holes for bolting to bench. Miter gauge, saw guard not included.
99 M1718L—Shpg. wt. 33 lbs. . \$18.95

Saw Guard Assembly for above. Automatically adjusts to work. With blade, guard splitter and non-kickback pawls.
9 M 21046—Wt. 2 lbs. 10 oz. . \$6.59

Miter Gauge. For table top.
9 M 2760—Wt. 5 lbs. 2 oz. 9.95

Craftsman Power-Pak. For table top. Centers power at 1 point.
9 M 21205—Shpg. wt. 1 lb. 3 oz. \$4.29

ORDER ON SEARS EASY TERMS . . see inside back cover

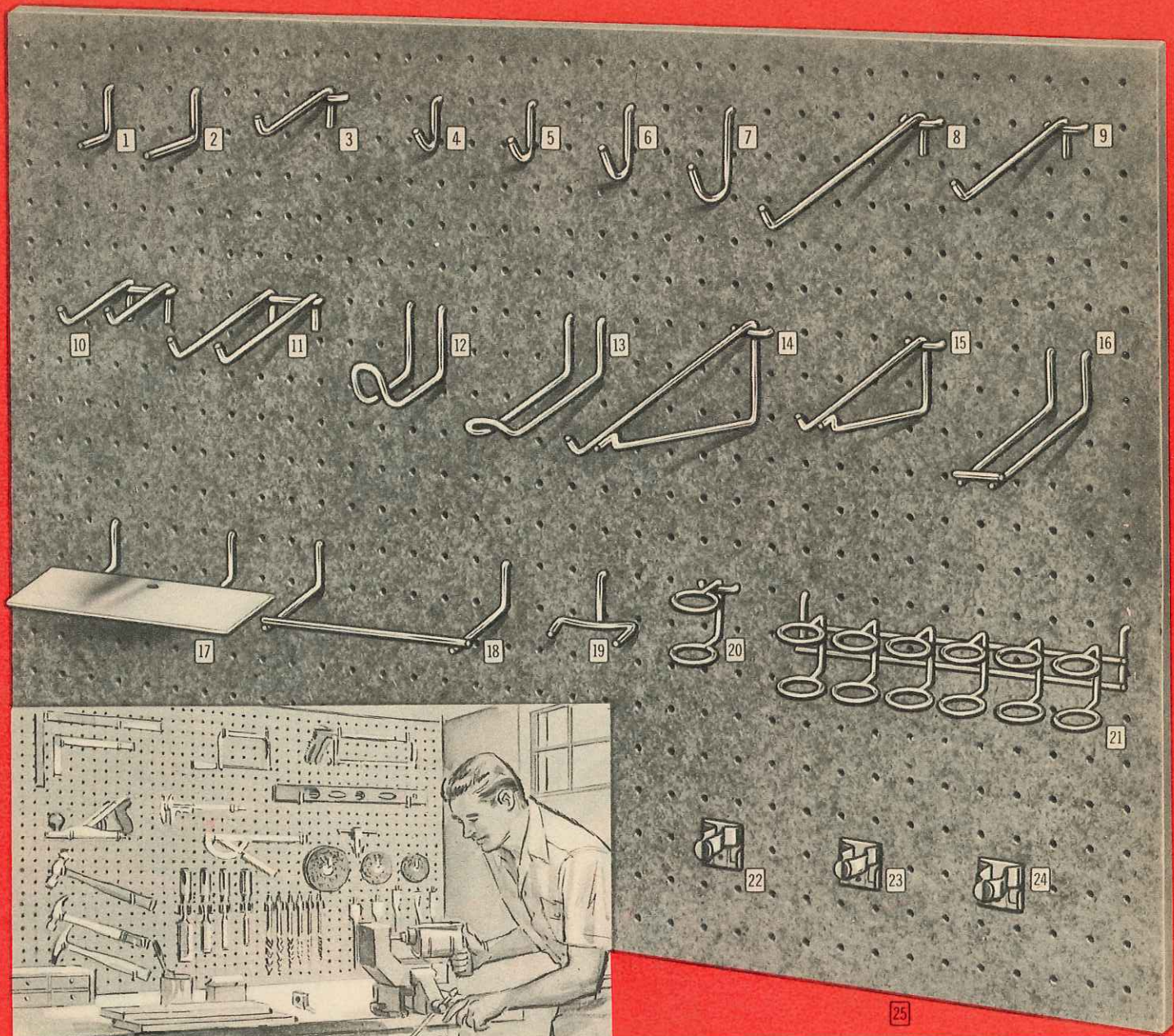

Keep Tools, Power Tool Accessories neatly arranged and handy . . put wasted space to use!

Perforated Board and Metal Fixtures convert walls or doors to storage area

Use these handy metal fixtures to mount *all* your tools on perforated board and you'll never waste time hunting for misplaced tools. Your saws and other cutting tools will stay sharp longer, too. You'll find dozens of uses for these tempered hardboard panels that are perforated to hold all hanging fixtures. Hang them anywhere . . in closet, garage, kitchen or in the workshop.



EASY TERMS

Sears Easy Terms help you to live better; see inside back cover for details

Catalog Number	Description	Size	Quantity	Shpg. wt.	Price
(1)	9 M 7531 Hooks . . . Straight . . .	Small—1-inch Pkg. of 12 5 oz 29c
(2)	9 M 7532 Hooks . . . Straight . . .	Medium—1½-inch Pkg. of 10 6 oz 29c
(3)	9 M 7533 Hooks . . . Straight . . .	Large—2-inch Pkg. of 4 4 oz 29c
(4)	9 M 7534 Loops	Small Pkg. of 12 6 oz 29c
(5)	9 M 7535 Loops	Medium Pkg. of 12 6 oz 29c
(6)	9 M 7536 Loops	Large Pkg. of 10 6 oz 29c
(7)	9 M 7537 Loops	Extra large Pkg. of 7 6 oz 29c
(8)	9 M 7544 Straight Single Hook	6 inch 1 only 3 oz 10c
(9)	9 M 7545 Straight Single Hook	4 inch 1 only 3 oz 9c
(10)	9 M 7550 Straight Double Hook	2 inch 1 only 3 oz 10c
(11)	9 M 7551 Straight Double Hook	4 inch 1 only 4 oz 10c
(12)	9 M 7542 Curved Double Hook	3 inch 1 only 3 oz 10c
(13)	9 M 7543 Straight Double Hook	4½ inch 1 only 3 oz 10c
(14)	9 M 7540 Shelf Bracket	8 inch 1 only 3 oz 15c
(15)	9 M 7541 Shelf Bracket	6 inch 1 only 3 oz 15c
(16)	9 M 7547 Shelf Support	4½ inch 1 only 7 oz 49c
(17)	9 M 7548 Metal Shelf	6 inch 1 only 7 oz 35c
(18)	9 M 7546 Hang Bar	2½x6 inch 1 only 3 oz 15c
(19)	9 M 7553 Plier Holder 1 only 2 oz 5c
(20)	9 M 7557 Single Tool Holders	1 lg.; 2 sml Pkg. of 3 5 oz 29c
(21)	9 M 7547 6-hole Tool Holder 1 only 7 oz 49c
(22)	9 M 7558 Spring Clips	Small Pkg. of 2 5 oz 29c
(23)	9 M 7560 Spring Clips	Medium Pkg. of 2 5 oz 29c
(24)	9 M 7559 Spring Clips	Large Pkg. of 2 5 oz 29c

Perforated Board Hook Assortment. Contains wide assortment of tool holders, spring clips, loop hooks, etc. Stabilizer for each hook. 9 M 7554—Shipping weight 1 lb. 4 oz. \$1.98

Perforated Board Hook Assortment. Starter set contains basic selection of hooks, loops, tool holders, etc. Stabilizer for each hook. 9 M 7556—Shipping weight 10 oz.79c

25 Tempered hardboard perforated Panels. Smooth, hard finish covered with prime coat of off-white. ¼ inch thick; holes 1 inch apart. For mounting hardware see below. 99 M 7552L—Please state size.

Panel Size	Shipping weight	Price per Panel
2x2 feet 4 pounds 79c
2x3 feet 5 pounds \$1.19
2x4 feet 7 pounds 1.59

Standard perforated Panel. 2x4 ft. x ¼ in. 99 M 7561L—Shipping weight 6 lbs.89c
9 M 7538—Mounting Hardware Set. Contains 6 each of screws, spacers, anchors. Shpg. wt. 3 oz. 29c

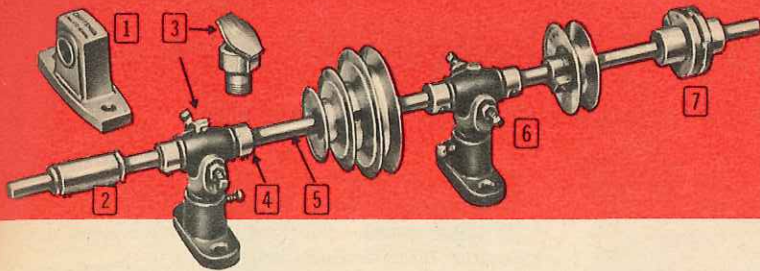

Line Shaft and Accessories

To drive several tools from permanently mounted electric motor. Can be mounted on bench, under bench, or for overhead drive. For best results use 1/2-horsepower motor or larger.

Line shaft: use 1/2-inch for light tools; 3/8-inch or 1/2-inch for heavier machines or larger motors. **Rigid couplings** connect sections of line shafting. **Line shaft collars** prevent endwise drift of shaft.

Flexible couplings connect motor to line shaft; are self-aligning. **Hangers** have bronze bearings, adjustable for shaft height. Space 1/2-inch hangers every 18 inches; 3/4-inch every 24 inches. **Hinged cap oiler** used in place of plugs.

Be sure to order by correct catalog number or numbers from table below.

Catalog No.	Accessory	Shpg. wt.	Each
1 .9 M 2750..	Pillow Blocks (Specify 1/2, 3/8 or 3/4-inch bore size).....	12 oz.	\$1.29
2 .9 M 2839..	Rigid Coupling (Specify 1/2, 3/8 or 3/4-inch bore size).....	6 oz.	.65c
3 .9 M 2820..	Hinged Cap Oiler 1/4-in. barrel.....	1 oz.	.9c
4 .9 M 2824..	1/2-inch line Shaft Collar.....	2 oz.	.29c
4 .9 M 2826..	3/8-inch line Shaft Collar.....	3 oz.	.29c
4 .9 M 2825..	3/4-inch line Shaft Collar.....	3 oz.	.29c
5 .9 M 2833..	1/2x24-inch Steel Shaft.....	1 lb. 15 oz.	.89c
99 M 2834C	3/8x48-inch Steel Shaft.....	3 lbs.	\$1.39
99 M 2830C	3/4x48-inch Steel Shaft.....	5 lbs.	1.98
99 M 2835C	1/2x48-inch Steel Shaft.....	5 lbs.	2.49
6 .9 M 2828..	Shaft Hanger (for 1/2-inch diameter Steel Shaft).....	1 lb. 8 oz.	2.39
.9 M 2846..	Shaft Hanger (for 3/8-inch diameter Steel Shaft).....	1 lb. 10 oz.	2.39
.9 M 2829..	Shaft Hanger (for 3/4-inch diameter Steel Shaft).....	1 lb. 12 oz.	2.39
7 .9 M 2840..	Flexible Coupling (Specify 1/2, 3/8 or 3/4-inch bore size).....	9 oz.	.89c

CRAFTSMAN Non-slip V-belts

REG. U.S. PAT. OFF.

Slip-resistant CRAFTSMAN V-Belts are built for maximum power transmission. Each belt has extra-heavy, closely woven cotton jacket around pliable, heat-resistant rubber. Each belt gives positive, non-slip grip. Reinforcing cords are pre-treated in liquid rubber.

HOW TO MEASURE: Measure with steel tape around outside edge of pulley (not in groove) to get correct length (circumference).

CRAFTSMAN 3/8-inch V-Belts. (B Section.) For V-pulleys 3 inches in diameter or larger. Lengths listed below are outside lengths. Be sure to order by correct catalog number.

Catalog Number	Length	Mfr's No.	Shipping weight	Each	Catalog Number	Length	Mfr's No.	Shipping weight	Each
9 M 1733	33 inches	5L330	6 ounces	89c	9 M 1738	38 inches	5L380	7 ounces	\$1.09
9 M 1734	34 inches	5L340	6 ounces	98c	9 M 17405	40 inches	5L400	7 ounces	1.19
9 M 1736	36 inches	5L360	6 ounces	98c	9 M 1752	52 inches	5L520	8 ounces	1.49

CRAFTSMAN 1/2-inch V-Belts. (A Section.) For V-pulleys 2 inches in diameter or larger. Lengths listed below are outside lengths. Be sure to order by correct catalog number.

Catalog Number	Length	Mfr's No.	Shpg. wt.	Each	Catalog Number	Length	Mfr's No.	Shpg. wt.	Each	Catalog Number	Length	Mfr's No.	Shpg. wt.	Each
9 M 1619	19 in.	4L190	4 oz.	69c	9 M 1634	34 in.	4L340	6 oz.	79c	9 M 1649	49 in.	4L490	7 oz.	98c
9 M 1620	20 in.	4L200	4 oz.	69c	9 M 1635	35 in.	4L350	6 oz.	79c	9 M 1650	50 in.	4L500	7 oz.	98c
9 M 1621	21 in.	4L210	4 oz.	69c	9 M 1636	36 in.	4L360	6 oz.	89c	9 M 1651	51 in.	4L510	7 oz.	98c
9 M 1622	22 in.	4L220	4 oz.	69c	9 M 1637	37 in.	4L370	6 oz.	89c	9 M 1652	52 in.	4L520	7 oz.	98c
9 M 1623	23 in.	4L230	4 oz.	69c	9 M 1638	38 in.	4L380	7 oz.	89c	9 M 1654	54 in.	4L540	7 oz.	98c
9 M 1624	24 in.	4L240	4 oz.	69c	9 M 1639	39 in.	4L390	7 oz.	89c	9 M 1656	56 in.	4L560	8 oz.	\$1.09
9 M 1625	25 in.	4L250	4 oz.	69c	9 M 1640	40 in.	4L400	7 oz.	89c	9 M 1658	58 in.	4L580	8 oz.	1.09
9 M 1626	26 in.	4L260	4 oz.	69c	9 M 1641	41 in.	4L410	7 oz.	89c	9 M 1660	60 in.	4L600	8 oz.	1.09
9 M 1627	27 in.	4L270	4 oz.	69c	9 M 1642	42 in.	4L420	7 oz.	89c	9 M 1662	62 in.	4L620	8 oz.	1.09
9 M 1628	28 in.	4L280	4 oz.	79c	9 M 1643	43 in.	4L430	7 oz.	89c	9 M 1664	64 in.	4L640	8 oz.	1.19
9 M 1629	29 in.	4L290	4 oz.	79c	9 M 1644	44 in.	4L440	7 oz.	98c	9 M 1666	66 in.	4L660	9 oz.	1.19
9 M 1630	30 in.	4L300	5 oz.	79c	9 M 1645	45 in.	4L450	7 oz.	98c	9 M 1670	70 in.	4L700	9 oz.	1.29
9 M 1631	31 in.	4L310	5 oz.	79c	9 M 1646	46 in.	4L460	7 oz.	98c	9 M 1672	72 in.	4L720	9 oz.	1.29
9 M 1632	32 in.	4L320	5 oz.	79c	9 M 1647	47 in.	4L470	7 oz.	98c	9 M 1684	84 in.	4L840	10 oz.	1.49
9 M 1633	33 in.	4L330	5 oz.	79c	9 M 1648	48 in.	4L480	7 oz.	98c					

CRAFTSMAN 3/4-inch V-Belts. (O Section.) Correct size for drives over 3 1/2 diameter pulleys. Lengths listed below are outside lengths. Be sure to order by correct catalog number.

Catalog Number	Length	Mfr's Number	Shipping weight	Each	Catalog Number	Length	Mfr's Number	Shipping weight	Each
9 M 1520	20 inches	3L200	4 ounces	69c	9 M 1530	30 inches	3L300	4 ounces	69c
9 M 1524	24 inches	3L240	4 ounces	69c	9 M 1534	34 inches	3L340	4 ounces	69c
9 M 1528	28 inches	3L280	4 ounces	69c	9 M 1537	37 inches	3L370	4 ounces	79c

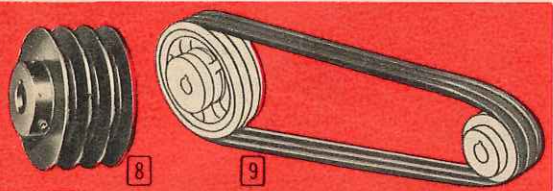

3 and 4-groove V-Pulleys

8 Heavy cast iron; balanced; true running. Bore sizes increase by 1/16-in. increments. Bore sizes in 3-groove, from 1/2 to 1 1/2 in. (up to 7.0-in. diam.); from 1/2 to 2 1/2 in. (from 7.8-in. to 18.8-in. diam.). Bore sizes in 4-groove, from 1/2 to 1 1/2 in. (up to 7.0-in. diam.); from 1/2 to 2 1/2 in. (from 7.8-in. to 18.8-in. diam.). Standard keyways in bores from 3/8 in. and larger. For 3/8-in. (B section) V belts. To determine pitch diam., subtract from outside diameter .4 in. when using 3/8-in. (B section). From factory in Chicago, Ill. State catalog number, diameter and bore size.

Outside diameter	3-groove		4-groove	
	Shipping weight	Each	Shipping weight	Each
F9 M 2905				
3.8 inches.....	4 pounds.....	\$7.98...	5 pounds.....	\$8.98
4.0 inches.....	4 pounds.....	7.98...	6 pounds.....	8.98
4.6 inches.....	5 pounds.....	7.98...	7 pounds.....	9.98
5.0 inches.....	6 pounds.....	8.98...	8 pounds.....	9.98
5.6 inches.....	7 pounds.....	9.98...	9 pounds.....	10.98
6.0 inches.....	7 pounds.....	10.98...	10 pounds.....	11.98
7.0 inches.....	9 pounds.....	11.98...	13 pounds.....	13.98
7.8 inches.....	14 pounds.....	12.98...	16 pounds.....	14.98
9.0 inches.....	16 pounds.....	13.98...	19 pounds.....	16.98
9.8 inches.....	17 pounds.....	14.98...	20 pounds.....	17.98
F9 M 2906K				
11.4 inches.....	20 pounds.....	16.98...	23 pounds.....	19.98
F9 M 2905K				
12.8 inches.....	23 pounds.....	19.98...	26 pounds.....	22.95
15.8 inches.....	30 pounds.....	22.95...	34 pounds.....	25.95
F9 M 2905L				
18.8 inches.....	43 pounds.....	25.95...	45 pounds.....	32.95

9 3/8-in. (B Section) Matched V-Belts for multiple drives. Extra heavy. Shpg. wts.: 38 to 63 in., 1 lb.; 68 to 183 in., 2 lbs.; 198 in., 3 lbs. From factory in Chicago, Ill.

Length	Mfr's No.	Each	Length	Mfr's No.	Each	Length	Mfr's No.	Each
38 in.	..B35..	\$1.59	68 in.	..B65..	\$2.49	108 in.	..B105..	\$3.89
41 in.	..B38..	1.79	71 in.	..B68..	2.59	115 in.	..B112..	4.19
45 in.	..B42..	1.89	78 in.	..B75..	2.79	123 in.	..B120..	4.49
49 in.	..B46..	1.98	84 in.	..B81..	2.98	131 in.	..B128..	4.79
53 in.	..B50..	2.19	88 in.	..B85..	3.19	147 in.	..B144..	5.39
54 in.	..B51..	2.19	93 in.	..B90..	3.39	161 in.	..B158..	5.89
56 in.	..B53..	2.19	96 in.	..B93..	3.49	176 in.	..B173..	6.59
58 in.	..B55..	2.29	100 in.	..B97..	3.69	183 in.	..B180..	6.79
63 in.	..B60..	2.39	103 in.	..B100..	3.79	198 in.	..B195..	7.29

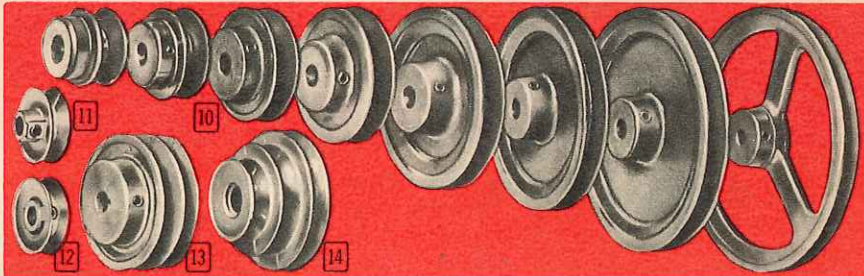

CRAFTSMAN V-Pulleys have precision-machined grooves . . run true

CRAFTSMAN pulleys are scientifically designed for greatest working efficiency and are carefully and accurately made to gain top working performance from machinery and power tools. Grooves are accurately machined so that belts will run true! All bores are reamed to exact size. Diameters given in the tables below refer to the outer edge of the pulleys, not to the pitch diameter or bottom of groove. State catalog number diameter and bore size.

HOW TO DETERMINE V-PULLEY DIAMETERS

Motor Pulley Diameter: Multiply diameter of machine pulley by machine RPM wanted. Divide by motor RPM for motor pulley diameter.
Machine Pulley Diameter: Multiply diameter of motor pulley by motor RPM. Divide by machine RPM wanted for machine pulley diameter.

10 CRAFTSMAN Cast Iron Single-groove V-Pulleys. Heavy duty. Professional quality. Use to replace single V-belt pulleys. Has socket head set screw. 1/2-in. bores have no keyway. 3/8-inch or larger bores have standard keyway. For 3/8 (O section) or 1/2-inch (A section) V-belts. Gray finish. State catalog number and bore size.

Catalog No.	Out. diam.	Bore, inches	Shpg. wt.	Each
9 M 2880	1 1/2 in.	1/2	3 oz.	79c
9 M 2881	2 in.	1/2	11 oz.	89c
9 M 2882	2 1/2 in.	3/8, 1/2, 5/8, 3/4, 7/8	15 oz.	\$1.19
9 M 2883	3 in.	1/2, 5/8, 3/4, 7/8	1 lb. 1 oz.	1.49
9 M 2884	4 in.	1/2, 5/8, 3/4, 7/8	2 lbs. 3 oz.	1.49
9 M 2885	5 in.	1/2, 5/8, 3/4, 7/8	2 lbs. 7 oz.	1.79
9 M 2886	6 in.	1/2, 5/8, 3/4, 7/8	3 lbs.	1.98
9 M 2808	8 in.	1/2, 5/8, 3/4, 7/8	4 lbs. 4 oz.	2.69
9 M 2810	10 in.	1/2, 5/8, 3/4, 7/8	4 lbs. 7 oz.	2.98
9 M 2812	12 in.	1/2, 5/8, 3/4, 7/8	5 lbs. 11 oz.	3.98
9 M 2814	15 in.	1/2, 5/8, 3/4, 7/8	9 lbs. 11 oz.	7.98

12 CRAFTSMAN Hubless V-Pulleys. Zinc alloy. Aluminum finish. Use side by side for multiple drives. Socket head set screw. For 3/8-in. (O section) or 1/2-in. (A section) V-belts, except 9 M 2901 for 1/2-inch only. 9 M 2902 and 9 M 2903 in 3/8 and 3/4-in. bores have standard keyway. State catalog number and bore size.

Catalog No.	Out. diam.	Bore, inches	Shpg. wt.	Each
9 M 2901	..2 in.	1/2, 5/8	..5 ounces	..69c
9 M 2902	..2 1/2 in.	3/8, 1/2, 5/8, 3/4	..6 ounces	..79c
9 M 2903	..3 in.	1/2, 5/8, 3/4	..7 ounces	..89c

13 CRAFTSMAN Cast Iron 2-groove V-Pulleys. Heavy cast iron; gray finish. For heavy production work. Machined grooves; precision-reamed bores. Standard keyways. 2 head set screws with wrench. For 3/8-in. (O section) or 1/2-in. (A section) V-belts. 9 M 2910—State pulley diameter and bore size wanted.

Out. diam.	Bore, inches	Shipping weight	Each
2 1/2 in.	3/8, 1/2	1 lb. 10 oz.	\$2.98
3 in.	3/8, 1/2, 5/8	2 lbs. 2 oz.	3.49
4 in.	3/8, 1/2, 5/8	3 lbs. 4 oz.	4.49
5 in.	3/8, 1/2, 5/8	5 lbs. 2 oz.	4.98
6 in.	3/8, 1/2, 5/8	5 lbs. 9 oz.	5.98
8 in.	1/2, 5/8, 3/4	8 lbs.	6.98
10 in.	1/2, 5/8, 3/4	11 lbs.	8.98

11 CRAFTSMAN Die-cast Single-Groove V-Pulleys. Zinc alloy . aluminum finish. Socket head set screw. 3/8 or 1/2-inch bores have standard keyway. For 3/8 (O section) or 1/2-in. (A section) V-belts, except 9 M 2800 which is for 3/8-in. belt only. State catalog no. and bore size.

Catalog No.	Out. diam.	Bore, inches	Shpg. wt.	Each
9 M 2800	1 1/2 in.	1/2	3 oz.	49c
9 M 2801	2 in.	1/2	5 oz.	69c
9 M 2802	2 1/2 in.	3/8, 1/2, 5/8, 3/4, 7/8	6 oz.	69c
9 M 2803	3 in.	1/2, 5/8, 3/4, 7/8	7 oz.	79c
9 M 2804	4 in.	1/2, 5/8, 3/4, 7/8	9 oz.	98c
9 M 2805	5 in.	1/2, 5/8, 3/4, 7/8	13 oz.	\$1.19
9 M 2806	6 in.	1/2, 5/8, 3/4, 7/8	1 lb. 1 oz.	1.59

14 CRAFTSMAN Die-cast Cone V-Pulleys. Aluminum finish. For variable speed applications. 3 or 4 step. Socket head set screw. For 3/8 or 1/2-in. V-belts. 3/8 and 3/4-in. bore have standard keyway. State bore size.

Catalog No.	Bore, in.	Step diam., in.	Shpg. wt.	Each
9 M 2788	1/2, 5/8, 3/4	3 3/8, 2 3/4, 2	1 lb.	\$1.39
9 M 2792	1/2, 5/8, 3/4	4, 3 3/8, 2 3/4, 2	1 lb. 4 oz.	1.69
9 M 2793	1/2, 5/8, 3/4	5, 4, 3, 2	1 lb. 10 oz.	1.98

Newly-designed CRAFTSMAN Capacitor Motors

REG. U. S. PAT. OFF.

More power per pound—up to 30% lighter than most other motors of same horsepower

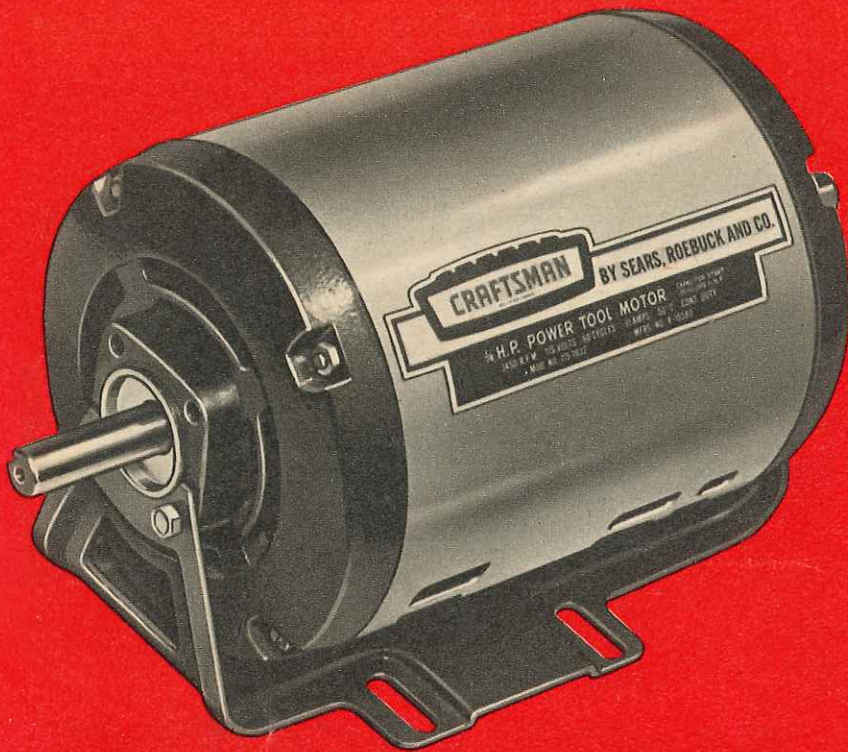

- Rated for continuous duty operation
- Mount in any position . . . has thrust bearings
- No oiling needed . . . lubricated for normal motor life
- Rotation direction easily reversed
- No starting switch problems . . . dustproof switch
- Safer . . . internal capacitor cuts voltage leaks
- Quick-connect terminals reduce wiring time

Low as **\$24⁹⁵** cash Sleeve bearing 1/2 HP, 3450 RPM **\$2.50 down**

These rugged motors power large drill presses, bench saws, feed grinders, other equipment. Direct replacement for G.E., Westinghouse, Emerson, Delco and other makes. Mounting dimensions: 3x4 3/4 in., built to N.E.M.A. standards. Tough, moisture-resistant Mylar insulation. Takes rigid or flexible conduit. Built-in grounding lug meets electrical codes. 5/8-in. diam. shaft. For 60 cycle AC. Guaranteed one year. Overload protector, manually reset.

With ball bearings, on-off switch, 8-ft. cord.

- 99 M 1968K—1/2-HP, 1725 RPM, Single-end shaft, 115-230-volts. Shipping weight 27 pounds. \$3.50 down..... Cash **\$34.95**
- 99 M 1982K—1/2-HP, 3450 RPM, Double-end shaft, 110-120-volts, Shipping weight 23 pounds. \$3.50 down..... Cash **32.95**
- 99 M 1977K—3/4-HP, 1725 RPM, Single-end shaft, 115-230-volts, Shipping weight 33 pounds. \$4.00 down..... Cash **38.95**
- 99 M 1992K—3/4-HP, 3450 RPM, Double-end shaft, 115-230-volts, Shipping weight 26 pounds. \$4.00 down..... Cash **36.95**
- 99 M 19099K—1-HP, 3450 RPM, Double-end shaft, 115-230-volts, Shipping weight 34 pounds. \$4.50 down..... Cash **44.50**
- 99 M 1988L—1 1/2-HP, 3450 RPM, 2-end shaft, 115-230-volts. No switch or cord. Overload protected. Shpg. wt. 58 lbs. \$5 down..... Cash **\$62.95**

With sleeve bearings, 4-ft. cord. No switch or overload.

- 99 M 1923K—1/2-HP, 3450 RPM, Double-end shaft, 110-120-volts, Shipping weight 22 pounds. \$2.50 down..... Cash **\$24.95**
- 99 M 1924K—3/4-HP, 3450 RPM, Double-end shaft, 115-230-volts, Shipping weight 25 pounds. \$3 down..... Cash **28.95**
- 99 M 1925K—1-HP, 3450 RPM, Double-end shaft, 115-230-volts, Shipping weight 27 pounds. \$4 down..... Cash **35.95**
- 99 M 1928K—1/2-HP, 1725 RPM, Single-end shaft, 115-230-volts, Shipping weight 27 pounds. \$3 down..... Cash **27.95**
- 99 M 1949K—3/4-HP, 1725 RPM, Single-end shaft, 115-230-volts, Shipping weight 31 pounds. \$3.50 down..... Cash **32.95**

GUARANTEE We will repair without charge, or replace with a current model of equal capacity, any Sears electric motor found defective in materials or workmanship, if returned within 1 year of purchase date.

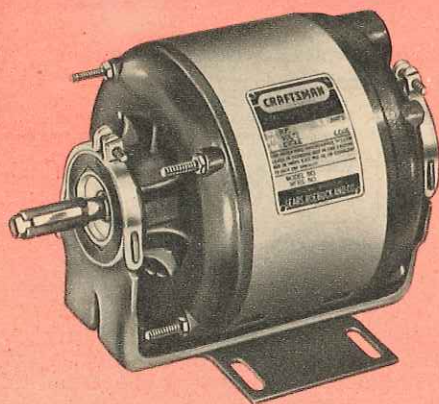

CRAFTSMAN Split Phase Motors

Power drill presses, wood and metal lathes, jig saws, grinders, belt sanders and farm equipment with easy-starting loads. Replacements for General Electric, Westinghouse, Emerson and Delco motors. Easily reversed, 110-120-volts, 60-cycle AC, 1725 RPM. 1/2-in. diam. single-end shaft with 5/8-inch sleeve adapter. Sleeve bearings with lifetime lubrication. Mounts in any position. Mounting dimensions: 3x4 3/4 in.; rubber mount. Without on-off switch or cord. Guaranteed one year against defects in materials and workmanship.

- 99 M 1934C—1/4-HP, Shipping weight 15 pounds..... **\$14.98**
- 99 M 19669C—1/2-HP, Shipping weight 16 pounds..... **16.98**
- 99 M 1935C—1/2-HP, Shipping weight 17 pounds..... **21.95**

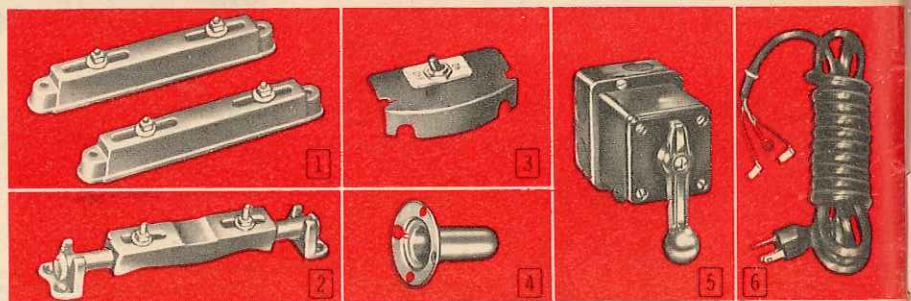

Electric Motor Rails, Switches, Safety Covers, Cords

- Adjustable Motor Rails.** For jobs where motor is not moved from one tool to another. To adjust belt tension, loosen bolts holding motor to rails and slide motor until correct adjustment is achieved. For motors of 1 HP and under. Maximum belt take-up 2 1/2 in. 9M2266—Wt. 1 lb. 4 oz., Pair **\$1.69**
- Floating Motor Rails.** For motors of 1 HP and under that power more than one tool. 2 3/4 to 5 in. between base-mounting holes center to center. 9 M 2265—1 rail and 1 pair of clips. Shipping wt. 15 oz. **\$1.29**
9 M 2268—1 pair of rail clips only. Shipping wt. 6 oz. **59c**
- On-off Motor Switch.** For motors of 3/4 HP capacity or less and for grinders listed on pages 32 and 33. With toggle handle. *Approved by Underwriters' Laboratories, Inc.* 9 M 1926—Shpg. wt. 5 oz. **98c**
- Motor Shaft Safety Cover.** Prevents damage to unused shaft on double-end shaft motors. Protects operator from becoming entangled in revolving shaft. Fits all double-end shaft capacitors listed above. Will not fit motors 9M1904 and 9M1909 on page 65. Ready for mounting. Mounting screws included with safety cover. 9 M 19672—Shpg. wt. 6 oz. **49c**
- Reversing Switch.** For above motors and most power tools. Stops and reverses split phase and capacitor motors. Not to be used with repulsion-induction motors or with motors using more than 550 volts. For AC voltage only. With instructions for installing. 9 M 2982—Wt. 1 lb. 9 oz. **\$.749**
- 3-wire Cord.** For CRAFTSMAN capacitor motors described and listed above. Covered with heavy, wear-resistant rubber insulation. 8 feet long. With 3-prong plug, without plug adapter. 9 M 1906—Shpg. wt. 1 lb. **98c**



\$44.50
cash \$4.50 down

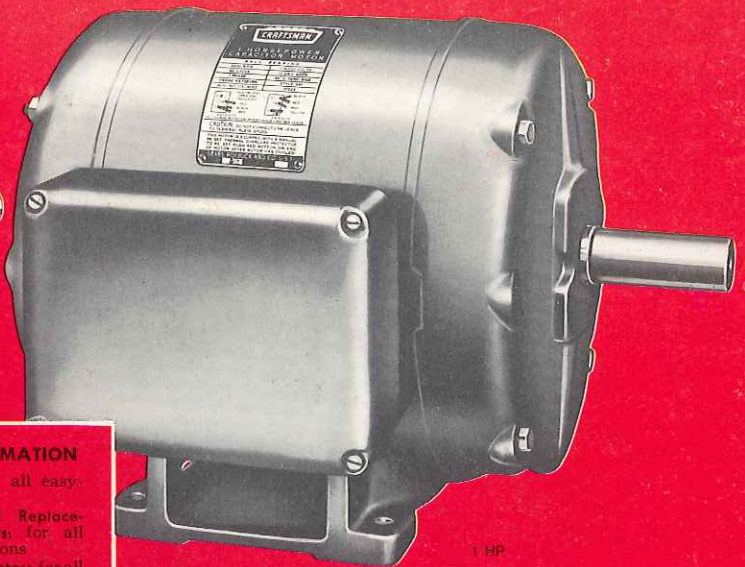

\$84.95
cash \$5.00 down

IMPORTANT INFORMATION

Split Phase Motors for all easy-starting applications
 General Purpose and Replacement Capacitor Motors for all hard-starting applications
 Heavy-duty Capacitor Motors for all extra-hard-starting applications

CRAFTSMAN Capacitor Motors
REG. U.S. PAT. OFF.
 Power hard-starting loads

Excellent for farm or shop. Pull large woodworking power tools (shapers, bench saws, jointer-planers, sanders). Also power chicken feeders, feed grinders and mixers, milking machines. "Break-down torque" (maximum turning strength) exceeds N.E.M.A. standards. Mount in any position.

Extra-tough Formvar insulation gives wiring added protection against heat, abrasion and moisture. Ball bearings shielded against dirt, lubricated for life. Built-in condenser reduces starting current. Easily reversed. "KLIXON" overload protector prevents burnout. Enclosed starting switch eliminates starting problems

caused by dust, dirt or wood shavings. Guaranteed one year against defects in materials and workmanship.

On-off switch in base. 3/8-inch double-end shaft extends 1 1/8 inches on both ends. 3/16-inch keyways. (For shaft end safety covers, see page 64). For continuous duty. 1 HP, 3450 RPM. 115-230-volts, 60-cycle AC. Overload protector manually reset. Mounting dimensions 5x5 1/2 inches. With 8-foot cord, unbreakable plug. Shpg. wt. 46 lbs.

99 M 1909L—1 HP.....Cash \$44.50

Same motor as above, but without cord, manually reset overload protector or on-off switch. Shipping wt. 45 lbs.

99 M 1904L—\$4 down.....Cash \$38.95

CRAFTSMAN Heavy-duty Capacitor Motors
REG. U.S. PAT. OFF.
 Power extra-hard-starting loads

For pumps, compressors, blowers, coolers, machine tools, conveyors, farm equipment and other extra hard-starting loads. Also replaces repulsion-induction motors, but requires less maintenance.

Starting torque averages 250% to 350% of full-load torque. For 115-230-

volts, 60-cycles AC. Easily reversed. Single-end shaft with keyway. Ball bearings lubricated for normal motor life, double-shielded against dirt. Thermal overload protector prevents burn-out. Manually reset. With sturdy cast iron base. Mount in any position. Guaranteed one year.

Catalog Number	Horse-power	RPM	Shaft Diameter	Key Width	Base Mounting	Shpg. wt.	Price
99 M 19389N	.1	1725	7/8 inches	3/16 inch	4 1/2 x 7 1/2 inches	75 lbs.	\$84.95
99 M 19409N	1 1/2	1725	7/8 inches	3/16 inch	5 1/2 x 7 1/2 inches	82 lbs.	109.95
99 M 19419N	.2	1725	1 1/8 inches	1/4 inch	5 1/2 x 8 1/2 inches	106 lbs.	149.95
99 M 19429N	.2	3450	7/8 inches	3/16 inch	5 1/2 x 7 1/2 inches	79 lbs.	119.95
99 M 19439N	.3	1725	1 1/8 inches	1/4 inch	7 x 8 1/2 inches	133 lbs.	189.95

SEARS SPECIAL EASY TERMS

ONLY \$5 DOWN
on Power Tools from \$50 to \$200

If Unpaid Balance Amounts to	We Shall Add for Credit Price	Monthly Payment
\$50.01 to \$55.00	\$6.50	\$5.00
55.01 to 60.00	7.00	
60.01 to 65.00	7.50	
65.01 to 70.00	8.00	
70.01 to 80.00	10.00	
80.01 to 90.00	12.00	
90.01 to 100.00	14.00	
100.01 to 110.00	15.00	6.00
110.01 to 120.00	17.00	
120.01 to 130.00	19.00	7.00
130.01 to 140.00	21.00	
140.01 to 160.00	25.00	7.50
160.01 to 180.00	29.00	
180.01 to 200.00	32.00	9.50

ONLY \$10 DOWN
on Power Tools over \$200.00

If Unpaid Balance Amounts to	We Shall Add for Credit Price	Monthly Payments
\$200.01 to \$220.00	\$35.00	\$10.50
220.01 to 240.00	38.50	11.50
240.01 to 260.00	41.50	12.50
260.01 to 280.00	45.00	13.50
280.01 to 300.00	48.00	14.00
300.01 to 320.00	51.00	15.00
320.01 to 340.00	54.50	16.00
340.01 to 360.00	57.50	17.00
360.01 to 380.00	61.00	18.00
380.01 to 400.00	64.00	19.00
400.01 to 420.00	67.00	20.00
420.01 to 440.00	70.50	21.00
440.01 to 460.00	73.50	22.00
460.01 to 480.00	77.00	23.00
480.01 to 500.00	80.00	24.00
500.01 to 520.00	83.00	25.00
520.01 to 540.00	86.50	26.00
540.01 to 560.00	89.50	27.00
560.01 to 580.00	93.00	28.00
580.01 to 600.00	96.00	29.00

Write for Special Terms on orders over \$600

Plan and equip your shop the easy way . . . on Sears Easy Terms. If your purchase totals \$20 or more, you need only a down payment of 10%. Handle the balance in easy monthly payments. For more information, visit your Sears Retail Store.

IMPORTANT NOTICE ABOUT PRICES

We reserve the right to change the price of any item in this catalog should the Federal, State or Local governments increase by taxes or otherwise the cost or selling price of any item shown in this book . . . we reserve the right to add such taxes or other increases of cost or selling to the prices shown. The prices shown in this catalog are good for the continental United States only.

Because of transportation costs, prices in your Sears, Roebuck and Co. retail store may vary slightly from the prices shown in this Tool Catalog

INDEX

Abrasives.....	26, 27	Patterns.....	23
Band Saws.....	18, 19	Planers.....	16, 17
Benches, Work.....	37	Planer Attachment.....	61
Benches, Power Tool.....	36	Polisher.....	48, 56
Bench Saws, Accessories.....	7-11, 14	Polishing Equipment.....	34
Bits, for Wood, Metal.....	28	Power-Pak.....	36
Clamps.....	25	Pulleys.....	63
Dado Sets.....	13	Radial Arm Saws, Accessories.....	1-6
Drill Presses, Accessories.....	29, 30, 31	Router, Portable and Accessories.....	54, 55
Elec. Drills, Accessories.....	48-53	Sabre Saws, Blades.....	58, 59
Elec. Drill Attachments.....	53	Safety Goggles.....	32
Elec. Hand Saws.....	60, 61	Sander for interchangeable motor.....	54
Electrical Accessories.....	36	Sanding Equipment.....	21, 24-27, 48, 52-57
Flexible Shafts, Accessories.....	34	Sanders, Sander-Polishers.....	56, 57
Floor Model Saw.....	14	Sander, Belt and Disc.....	24
Gem Makers, Accessories.....	35	Saw Blades, Circular.....	6, 12
Glue.....	25	Saw Horse Brackets.....	36
Grinders, Grinding Wheels.....	32, 33	Shaper.....	23
Hack Saws, Power.....	38	Shaper Cutters.....	29
Impact Tool.....	48	Shaper Table for interchangeable motor.....	55
Instruction Manuals.....	6, 20	Sharpener, Saw.....	14
Jig Saws, Blades.....	22	Swing Saw.....	14
Jointer-Planers.....	16, 17	Switches, Electrical.....	36, 64
Jointer-Planer for interchangeable motor.....	54	Thickness Planers.....	16
Lathes, Metal and Accessories.....	39-43	Tool Board, Perforated.....	62
Lathes, Wood and Accessories.....	20, 21	Tool Post Grinder.....	35
Lineshafts, Accessories.....	63	Tool Stands.....	37
Lights, Tool Bench.....	36	Vacuum Cleaner for shop.....	15
Mandrels.....	35	V-Belts.....	63
Molding Cutter Head, Bits.....	13	Vises.....	47
Milling Machine Accessories.....	40	Welders, Arc and Accessories.....	44, 45
Motors, Accessories.....	64, 65	Welding Equipment, Oxy-acetylene.....	46, 47
Motors, Replacement.....	66	Wheels, Cut-off.....	26

SEARS GUARANTEE

We guarantee that every article in this catalog is honestly described and illustrated . . . We guarantee that any article purchased from us will give you the service you have a right to expect . . . If for any reason whatever you are not satisfied with any article purchased from us, we want you to return it to us . . . We will then exchange it for exactly what you want, or will refund your money.

SEARS, ROEBUCK AND CO.

Zone 1 SEARS 65

Save up to 1/2 the cost of replacing worn-out motors..install them yourself



These CRAFTSMAN Motors replace Westinghouse, General Electric, Delco, Emerson and other makes. They are so easy to install . . . just remove

the worn-out motor from mounting and put your CRAFTSMAN motor in place. Make the change in minutes with only a few basic tools.

Wringer Washer Motor

- [1] 1/2 HP, 1725 RPM split phase, 115-volt, 60-cycle AC. Fits most washers. 1/2-inch flatted shaft; 3/16 and 1/4-inch drilled holes in shaft to fit Easy, Philco and Kenmore wringer models. Universal mounting for other makes. Extended through bolts for end bell mounting. Reversible rotation (at terminal board). Without switch, cord, plug or overload protector. Guaranteed 1 year. See guarantee . . . inside back cover.

99 M 1989—Shipping weight 13 pounds. \$15.95

Blower and Fan Motors

- [2] Single-speed Blower Motors. Replace 1/4, 1/2 HP, 1725 RPM split phase, 115-volt, 60-cycle AC. Automatic reset overload protector. Rated 5.8 amps. Reversible rotation. Single-end 1/2-inch flatted shaft, 5/8-inch shaft adapter. Sleeve bearings. Mounting dimensions: 3x4 1/2 inches. (56 frame) or 2 1/16 x 4 1/4 inches. (48 frame).

99 M 1983C—56 frame. Shpg. wt. 20 lbs. \$19.95

99 M 19835C—48 frame. Shpg. wt. 19 lbs. 19.95

Two-speed Cooling Fan Motor. As above but without overload protector. 1140, 1725 RPM.

99 M 1971K—Shipping weight 30 pounds. . . . \$24.50

99 M 1972—Automatic overload protector for 99 M 1971K above. Externally applied. Wt. 5 oz. . . \$1.98

Sump Pump Motor

- [3] Double-pole switch with weights and chain are included. Fits most cellar drainers and sump pumps including Homart. Also replaces motors with built-in switch, rod and float. 1/2 HP, 1725 RPM split phase. 110-120-volts, 60-cycle AC. 1/2-inch diam. shaft. With automatic reset overload switch. Rotation easily reversed.

Accommodates 1 1/2-inch OD or 1 1/8-inch ID pipe. Guaranteed for 1 year.

99 M 1995C—Shipping weight 18 pounds. \$19.95

Jet Pump Motor

- [4] Capacitor starting with 65% overload capacity. 3450 RPM. Clockwise rotation only. Automatic overload reset switch. 5/8-inch diameter shaft. Bearings protected by grease seals. 4 mounting lugs; 5 1/2 inches between opposite lugs. With standard N.E.M.A. face mounting.

Will not fit Homart pumps. Without switch, cord or plug. Guaranteed 1 year against defects in materials and workmanship.

Catalog No.	HP	Voltage	Amps.	Shpg. wt.	Price
With flatted 5/8-inch diameter shaft					
99 M 1990K	1/2	115	5.8	25 lbs.	\$26.50
99 M 1991K	1/2	115-230	8-4	27 lbs.	29.50
With 7/16x20-inch threaded stainless steel shaft					
99 M 19905K	1/2	115	5.8	25 lbs.	\$28.50
99 M 19915K	1/2	115-230	8-4	27 lbs.	31.50

Oil Burner Motor

- [5] Replaces both 1/4 and 1/2 HP oil burner motors. 1/2 HP, 1725 RPM split phase. 110-120-volts, 60-cycle AC. Rotation easily reversed at terminal board. Manual reset overload switch. Standard N.E.M.A. mounting. 1/2-inch diameter flatted shaft. Sleeve bearings. 2-lug flange mounting. 7 1/2 inches between lug centers. 20-inch lead. Without switch, cord or plug. Guaranteed 1 year against defects in materials and workmanship.

99 M 1984K—Shipping weight 24 pounds. \$19.95

Compressor and Pump Motors

- [6] Capacitor motors with extra torque to power air compressors, pumps and other hard-starting equipment. Manual reset. Overload protector. Easily reversed. Sleeve bearings. Mount any position. Single-end shaft, 3/16-in. keyway. Cradle-type base. Without switch, cord, plug. Guaranteed 1 year.

99 M 1970K—1/2 HP, 1725 RPM, 110-120-volt, 60-cycle AC. Mounting dimensions: 3x4 1/4 in. With rubber mount. Shipping weight 26 pounds. \$22.95

99 M 1965K—1/2 HP, 1725 RPM, 115-230-volts, 60-cycle AC. 1/2-in. shaft with 5/8-in. adapter. Mount. dimensions: 3x4 1/4 in. Rubber mount. Wt. 26 lbs. \$28.95

99 M 19659K—3/4 HP, 1725 RPM, 115-230-volts, 60-cycle AC. 3/8-in. shaft. Mount. dim.: 3x4 3/4 in. Rigid mount. Wt. 28 lbs. . . \$36.95

99 M 1987L—1 HP, 1725 RPM, 115-230-volts, 60-cycle AC. 3/4-in. shaft. Mount. dimensions: 5x5 1/4 in. Rigid mount. Wt. 61 lbs. \$56.95

SEARS, ROEBUCK AND CO. . . Stores in most major cities