



**POWER TOOLS**  
**CRAFTSMAN** AND **COMPANION**  
REG. U. S. PAT. OFF. REG. U. S. PAT. OFF.  
**POWER TOOLS**

**NEW 1939 MODELS**

**SEARS, ROEBUCK AND CO.**

**THE WORLD'S LARGEST DISTRIBUTOR OF POWER TOOLS**

# FACTORIES EVERYWHERE ACCEPT

## Sears Power Tool Leadership

### GUARANTEE

WE GUARANTEE EVERY CRAFTSMAN OR COMPANION POWER TOOL AS WELL AS EVERY MACHINE, MOTOR OR ACCESSORY SHOWN IN THIS CATALOG TO BE EXACTLY AS DESCRIBED AND ILLUSTRATED, TO GIVE YOU PERFECT SATISFACTION AND TO REPRESENT FULL VALUE FOR THE PRICE PAID. IF YOU ARE NOT FULLY AND COMPLETELY SATISFIED WITH YOUR PURCHASE, RETURN IT TO US AND WE WILL REFUND YOUR MONEY TOGETHER WITH ANY TRANSPORTATION CHARGES YOU MAY HAVE PAID.

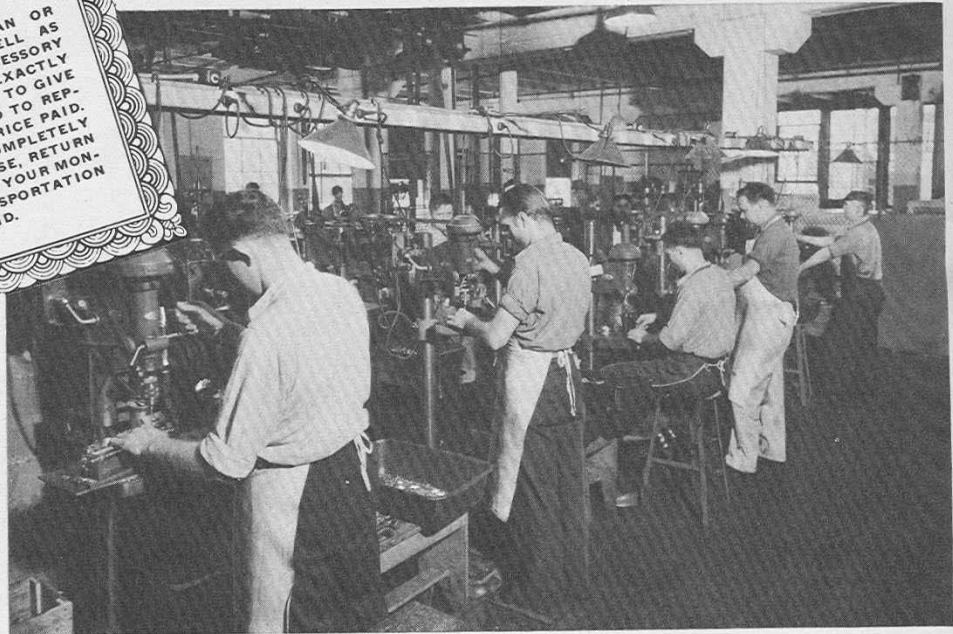

### INDEX

Aprons.....	24
Band Saws and accessories.....	11-13
Belts, Pulleys and accessories.....	41
Bench Saws and accessories.....	1-5
Bench, Work.....	40
Blue Prints.....	40
Carving Machine.....	30
Carving Tools.....	30
Drill Presses and accessories.....	24-29
Electric Drills and accessories.....	36
Flexible Shaft and accessories.....	22, 23
Glue Pots.....	24
Grinders and accessories.....	38, 39
Hack Saw, power driven.....	6
Instruction Books.....	40
Jig Saws and accessories.....	24, 33-35
Jointer-Planers and accessories.....	8, 9
Lathes and accessories.....	14-21
Line Shafting and accessories.....	41
Machine Stands and cabinets.....	40
Metal Working Lathes and accessories.....	14, 15, 20, 21
Motors and accessories.....	42, 43
Motor Rails.....	42
Paint Sprayers.....	44, 45
Planer, Thickness.....	9
Polishing Heads.....	38
Precision Tools.....	37
Pulleys, Belts, and accessories.....	41
Rotary Tool.....	31
Sanders and accessories.....	32
Shapers and accessories.....	10
Saw Blades for bench saws.....	3
Sprayers, Paint.....	44, 45
Tool Clips.....	19
Trestle Joints.....	40
Vises.....	37
Welders, Arc and Acetylene.....	6, 7
Wood Working Lathes and accessories.....	14-19
Work Benches.....	40



### Repair Parts

You will find a plate like this on all Sears major power tools. It is the key to America's finest system for repair parts of power tools. With every tool you receive a listing of the parts and their numbers. If you ever need repair parts give us the model number and part number—and you'll have your part in a hurry. Developing this elaborate system has cost a good deal of money. We believe it is money well spent—because it insures satisfaction for our customers.

Copyright 1938 by Sears, Roebuck and Co. Printed in U. S. A.

HERE'S dramatic and convincing proof of the quality of Sears Power Tools! In the picture above you see a bank of our CRAFTSMAN drill presses in one of the large industrial plants of Chicago. Day after day, under a steady, grueling grind, they have been meeting the most exacting demands of production jobs which require the utmost in accuracy, versatility, and rugged, long-life construction.

You will find Sears Power Tools of all types giving this same satisfactory service in factories and industrial plants all over the country—just another proof that you can rely on Sears Power Tools for finer and better

engineered products. Before any Sears tools are accepted and installed by these large organizations they have been checked by skilled machinists and experienced purchasing agents. They must stand up under the most critical inspections of materials and workmanship to prove that they will *continue* to perform perfectly through years of service.

This means that when you buy Sears power tools you rely not only on *our* guarantee and *our* careful factory tests—but in addition you know they have passed the tests of critical technicians who were not selling the tools, but were buying them.

### Sears Lead the World in Power Tool Sales

It is little wonder, then, that Sears have become the nation's headquarters for quality power tools. Years of development . . . the combined thinking of our own expert engineers and those of America's foremost power tool manufacturers . . . the selection of finest materials, parts and accessories . . . all these factors combined with Sears vast buying power have made it possible for us to become the largest distributors of power tools in all the world.

The CRAFTSMAN and COMPANION Power Tools in this book had their beginning in sound engineering. Through close contact with the needs of countless power tool users our designers have

been able to incorporate in CRAFTSMAN and COMPANION Power Tools the ideas of America's craftsmen and factory production men all over the country.

Sears tremendous volume permits heavy investment in new machinery, tools and dies. Mass production benefits the user by giving him—by giving you—finer, better engineered products at prices that always save him money. And don't forget—all Sears Power Tools are backed by a Guarantee that has been nationally famous for over fifty years.

### You Can Buy Sears Power Tools on Easy Terms

Does a lack of ready cash prevent you from adding a needed new power tool to your workshop? If so—use Sears Easy Payment Plan. By paying a small amount down and the balance monthly you can pay for your tools while you are using them. And, remember, whether you buy for cash or on easy payments—Sears give you rock-bottom prices.

If you want to buy Power Tools on Easy Payments at one of our retail stores, ask for information about our Easy Payment Plan. If you order

by mail, refer to your Sears General Catalog for the Easy Payment information.

**Important Price Information.** Should the Federal Government or any State find it necessary to increase by taxes or otherwise the cost or selling price of any of the merchandise described in this Catalog, we reserve the right to add any such taxes or other increases of cost or selling to the prices shown in this catalog.

R.F.54057-Z-1-8.16.38

# COMPANION

REG. U. S. PAT. OFF.

## BENCH SAWS for Accuracy and Durability

**\$6<sup>95</sup>**

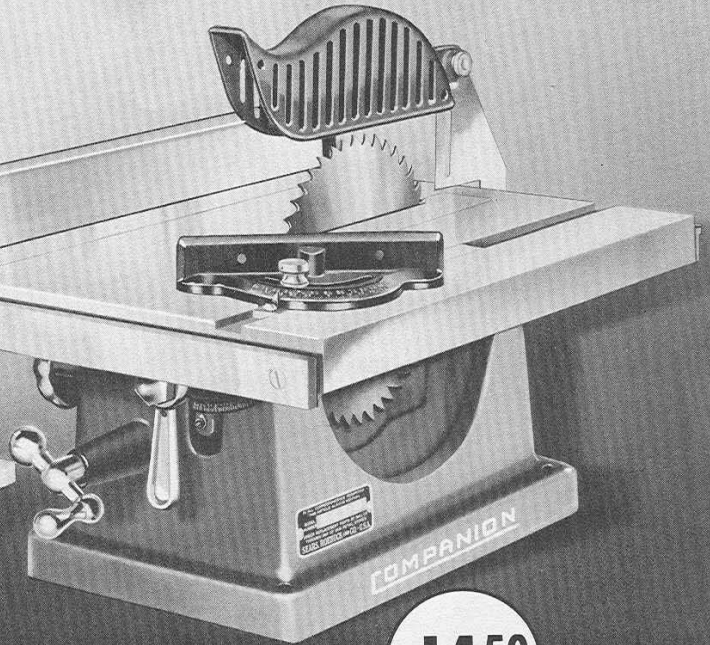

**\$14<sup>50</sup>**

### COMPANION 6-IN. BENCH SAW

- Auto-lubricating bronze bearings.
- 6-in. combination blade cuts miter joints. Depth of cut, 1½ inches.
- Sturdy cast iron base. Over-all height, 10½ inches; width, 11 inches. Length, 14¾ inches.
- Table, 10x12¾ inches, tilts to any angle up to 45 degrees.

This 6-inch bench saw is a fine example of the values you will find throughout the COMPANION line. COMPANION tools are built to a quality standard—made of fine materials, carefully machined, accurately assembled. At their price they have the largest capacity which it is possible to get and still use good workmanship and materials. Check the specifications of this 6-inch bench saw—you'll be surprised at the quality features we include. The saw arbor revolves in auto-lubricating bronze bearings, sealed against dust and dirt. Miter gauge is included for cutting-off operations. Rip fence is rigid construction with positive lock. Saw guard and splitter built for utmost safety. Table is gray iron ground to a high finish. Table tilts to any angle up to 45 degrees and has adjustable stops at 90 and 45 degrees allowing you to make angle cuts. Shipping weight, 24 pounds.

99 P 2226.....\$6.95

### NEW AND IMPROVED COMPANION 7-INCH BENCH SAW

- New large table 12¼ in. wide; 16¾ in. long. Ground finish.
- New massive base completely encloses operating mechanism.
- Dual control ripping fence, made of heavy reinforced steel.
- New rip fence has two separate locks for front and rear locking; both operate from front.
- 7-inch combination blade gives depth of cut from 0 to 2¾ inches.
- Depth of cut easily adjusted by ball crank and gear mechanism, which raises and lowers table.
- Table tilts to any angle from 90 to 45 degrees. Removable dado insert.
- Auto-lubricating bronze bearings. Miter gauge and safety guard.

New! Improved! See for yourself if it hasn't all the features found in saws selling for \$20.00 or more! Notice the many improvements in this new model—the larger table... the heavier, more accurate construction... the larger size semi-steel base... the improved dual control rip fence of heavy, reinforced steel. Cuts through the toughest, hardest wood with ease. Has latest type auto-lubricating bronze bearings which filter all oil supplied to saw arbor. Journals are protected against particles of foreign material. This insures long life and smooth operation. Saw arbor is accurately machined—runs true under heaviest loads.

New large size, one-piece, semi-steel base (7¾x12¾ in.) is rigidly braced. Newly designed, extra-large, tilting type, semi-steel table (12¼x16¾ in.) is heavily ribbed for greatest strength; carefully ground. Adjustable miter gauge, has easily read scale.

Improved rip fence locks at both front and rear. One knob locks fence at front and the other locks it at the rear. Rugged, easily-adjusted guard is mounted on splitter. Complete with 2-in. pulley on machine, miter gauge, guard, splitter and rip fence.

99 P M 2171—Without motor. Shipping weight, 49 pounds.....\$14.50  
99 P M 2172—As above with ¼-H.P. 110-volt 60-cycle A.C. COMPANION ball bearing motor 99 P 5607 shown on Page 43, 4-inch motor pulley and 42-inch V belt. Shipping weight, 78 pounds.....\$24.45

**Easy Terms**  
ON ORDERS OF \$20 OR MORE  
SEE INSIDE FRONT COVER

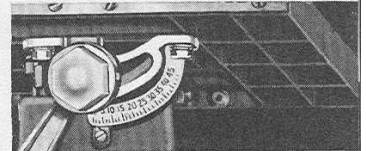

The table gauge shown above enables you to quickly adjust table to any desired angle. Accurately calibrated pointer shows exact angle of tilt. Large wrench clamps table securely in desired position.

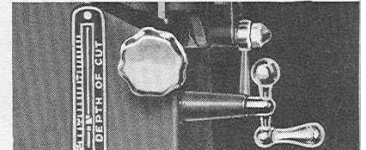

Ball crank handle raises and lowers entire table, thus changing depth of cut of blade. Exact depth of cut shown on scale. Large hand knob clamps table securely in position desired.

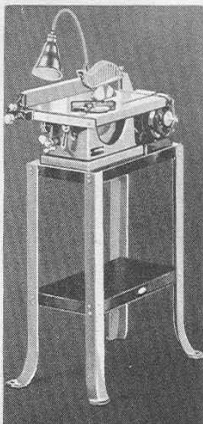

### COMPANION Machine Stand

Rugged 12-gauge steel. Top and shelf strongly secured to legs. Legs provided with holes for adjusting height of top or motor shelf. Packed flat for shipping. Top, 10x21 in. Ht., 31 in. Shpg. wt., 33 lbs.  
99 P 2744.....\$4.85

### COMPANION Tool Light

The 15-in. flexible neck lets you bring the light down to your work. Adjustable clamp fastens almost anywhere. Large reflector keeps the light out of your eyes—a real safety feature. Over-all length, 23 inches. Complete with push switch in socket, clamp, cord and plug. Shipping weight, 1 lb. 12 oz.  
9 P 2264.....\$1.60

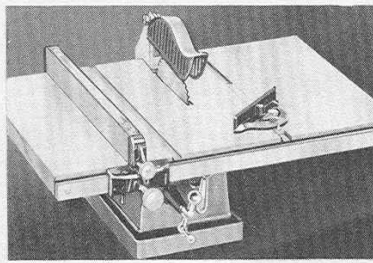

### Extension Table for Large Work

**\$4<sup>95</sup>**

These table extensions are accurately made and carefully finished. They fit perfectly and provide a solid surface for work. Give more working space. Set includes 2 steel side extensions each

5½ inches by 16¾ inches, with all necessary bars and fittings. Will accommodate rip fence. Easily fitted to your saw to give a total working area 23½ inches wide by 16¾ inches long. Complete with necessary support bars, bolts and necessary fittings for attaching to machine. Add these extensions to the bench saw above and you'll have a machine that can handle jobs which would ordinarily overtax the capacity of a larger saw.

9 P 2174—Shipping weight, 5 pounds.....\$4.95

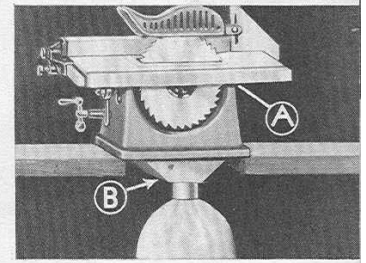

### Dust Collecting Outfit

Keep your workshop free of flying dust. Consists of dust guard (A) and sawdust chute (B) for attaching to base of your 7-inch bench saw. Dust bag collects sawdust.

9 P 2246—Shpg. wt., 5 lbs.....\$1.35

SEAR  
WIT

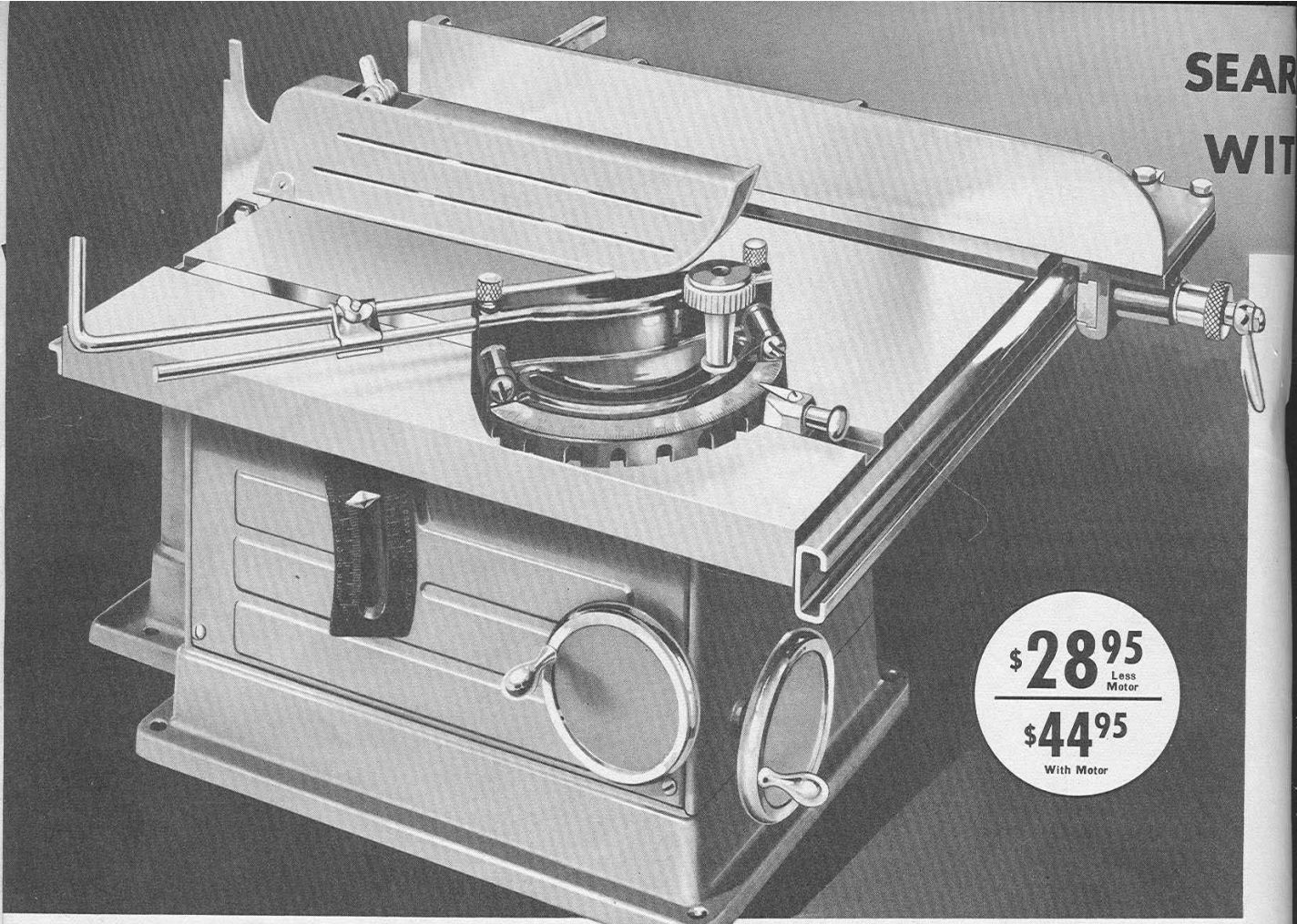

\$28<sup>95</sup>  
Less  
Motor

---

\$44<sup>95</sup>  
With Motor

## CRAFTSMAN

# 8-Inch BALL BEARING BENCH SAW

- 8-inch combination saw blade gives 2½-inch depth of cut.
- Equipped with precision SKF ball bearings for long life.
- Exclusive new "Roll-Over" rip fence. Width of rip shown on gauge.
- Large table, grooved for miter gauge. Miter gauge is indexed.
- Table tilts to any angle up to 45 degrees on heavy trunnions.
- Double pivot guard with splitter and spring-loaded kick-backs.
- All controls are equipped with gauges for accurate work.

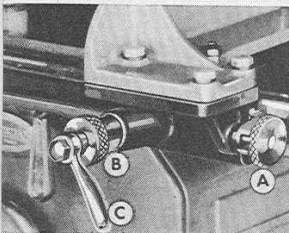

End view of Sears revolutionary new "Roll-over" fence, showing: (A) vernier adjustment; (B) lock on vernier adjustment; (C) main lock for entire fence.

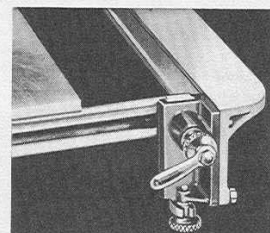

View of fence in rolled over position, showing how this exclusive Sears feature provides extra table space and allows you to get the fence out of the way for cross cutting without removing it from the machine.

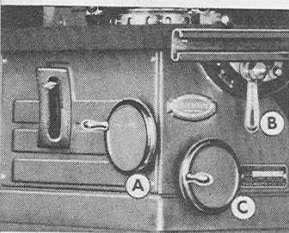

View of controls under table, showing (A) tilting control for adjusting table to any desired angle; (B) positive acting lock on tilting mechanism; (C) control for depth of cut. Controls are at your finger tips.

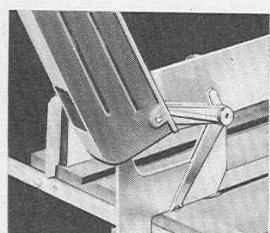

Guard raised to show the spring-loaded kick-backs. Double pivot arrangement allows guard to move both back and up as the work approaches the blade. Very smooth in operation. Guard can be tilted back completely out of way, without removing it from the machine.

Here's one of the most outstanding improvements made in power tool design in recent years! We've taken our most popular bench saw and equipped it with an altogether new type of rip fence (patent applied for)—much more efficient and convenient than ANY fence ever used before. You'll find nothing like it on any other bench saw in the world—no matter what you pay!

When this new fence is moved to the end of the front bar, it strikes a stop and pivots down flat, level with the table surface. It's never necessary to remove it for cut-off work. And even more, in this rolled-over position it acts as a table extension to give a larger working surface. There's a built-in vernier adjustment for making the fence level with the table or setting the fence to the cut you want.

Notice the many other outstanding features of this CRAFTSMAN 8-inch bench saw. Rugged strength—fine quality in every detail of construction. The saw blade and arbor are mounted on precision SKF ball bearings packed in grease and sealed against dirt and sawdust. The guard is entirely different in design and construction—far more convenient and efficient than most

types. It's equipped with a splitter and a set of fully enclosed, spring-loaded kick-back dogs. It is mounted with a double pivot arrangement that allows guard to move back and up as the work is pushed in. At the same time, it keeps the blade entirely covered. This type of construction costs much more than the usual type, but it means far more efficient operation of the guard.

Controls are equipped with accurate gauges—indicating depth of cut, depth of dado cut, angle of tilt of table, angle of miter gauge and width of rip.

Check the features above, and the specifications on the opposite page! See for yourself why this CRAFTSMAN had become our most popular bench saw even before we added the new "roll-over" fence! Shpg. wt., 95 lbs.

99 PM 2176—CRAFTSMAN 8-in. Bench Saw complete with indexing miter gauge, "roll-over" fence and guard. Without motor.....\$28.95

99 PM 2177—Same as above with 99 P 5587 ½-H.P. 110-volt 60-cycle capacitor type motor described on Page 43, ½x42-inch V. belt and 2½-inch motor pulley. Shipping weight, 126 pounds.....\$44.95

Easy Terms! ON ORDERS OF \$20 OR MORE SEE INSIDE FRONT COVER

# OFFER AMERICA'S MOST POPULAR BENCH SAW I THE EXCLUSIVE NEW ROLL-OVER FENCE

## SPECIFICATIONS

**BLADE:** High quality 8-inch combination type; 1/2-inch hole.

**DISTANCE IN FRONT OF BLADE:** 8 inches. With extensions, 13 1/2 inches.

**DEPTH OF CUT:** 2 1/2 inches. Blade may be raised and lowered by hand wheel with self-locking screw mechanism.

**DEPTH OF CUT SCALE:** Graduated in 16ths of an inch. Separate scale indicates depth of cut for 5/2-inch dado cutters.

**ARBOR:** Mounted in heavy housing. Equipped with two sealed precision SKF ball bearings packed in grease. Arbor housing is mounted on pivots in an adjustable housing on base for perfectly aligning the saw with the protractor slots in the saw table.

**RIP FENCE:** New, exclusive "Roll-over" type. Gets the fence out of the way in a hurry and provides an extension at the same time. See opposite page for description.

**MITER GAUGE:** Equipped with indexing device. Stops provided for important angular positions.

**GUARD:** Automatic leveling type with improved double pivot mounting. Mounted on splitter. May be thrown back out of way without removal from the saw. See opposite page for details.

**KICK-BACK DOGS:** Mounted on splitter. Spring controlled; concealed within guard.

**TABLE:** Heavy and well ribbed with smoothly ground finish. Size, 15 1/4 x 18 3/8 inches. With extensions shown at right, 26 1/2 x 24 3/8 inches. Recess for dado is carefully machined for perfect fit.

**TABLE MOUNTING:** Extra large tongue and groove type trunnions.

**BASE:** 10x18 3/4 inches; rugged gray iron casting.

**OVER-ALL DIMENSIONS:** 10 7/8 inches high; 15 1/4 inches wide; 22 inches long.

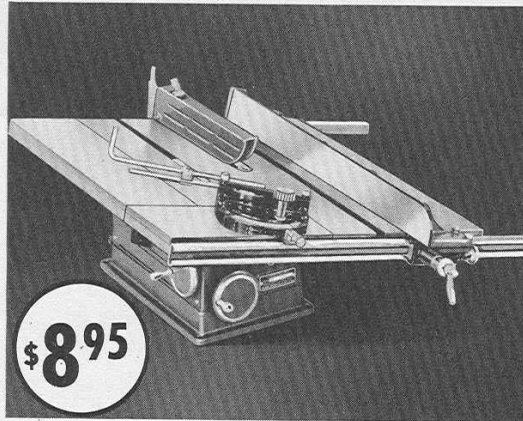

**\$8.95**

### Extension Tables for Large Work

For bench saw No. 99 PM 2176. These table extensions are accurately made and carefully finished. They fit perfectly and provide a solid surface for work. Set includes 2 front extensions, two side extensions, and extension to lengthen rip fence. Front extensions are gray iron, ground and polished. Side extensions are steel. Easily fitted to your saw to give a total working area 26 1/2 by 24 3/8 inches. Complete with necessary support bars, bolts, fittings and long extension for rip fence. Shipping weight, 31 pounds.

9 P 2179.....\$8.95

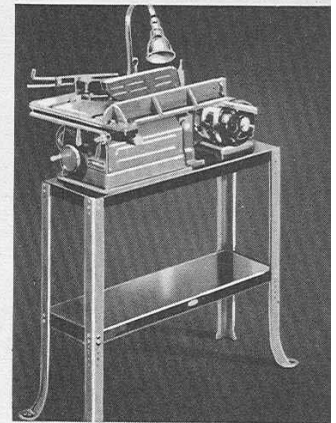

### Machine Stand

All steel, strong and rigid. Top, 10x34 in.; 31 in. high. 99 P 2745—Shpg. wt., 36 lbs. \$5.75

### Tool Light

Clamps almost anywhere. 15-in. flexible neck, reflector, cord, plug. Shpg. wt., 1 lb. 12 oz. 9 P 2264.....\$1.60

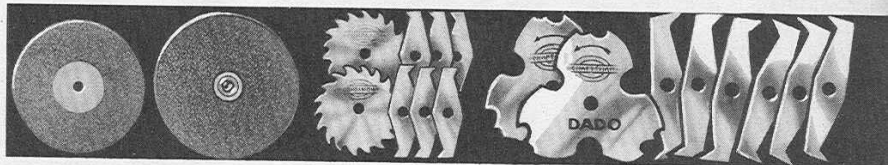

### Sanding and Cutting Discs

Specify 1/2-in. hole for saw shown on these 2 pages; and 3/4-in. hole for saws shown on Pages 4 and 5.

9 P 2272—High quality 8-inch steel sanding disc wheel. State bore.....\$1.60  
Shipping weight, 4 pounds.....

9 P 2273—Six 8-in. sanding discs, coarse and fine, for above wheel. Shipping weight, 10 ounces.....45c

9 P 6470—8-in. metal cutting wheel, 3/2 in. thick. State bore. Shipping weight, 1 pound 14 ounces.....\$1.10

### COMPANION 4-In. Dados

2 outside saws, 6 chippers. 1/2-inch hole. Shipping wt., 15 ounces.

9 P 4887..\$2.45

9 P 4883—Outside Dado Saw only. Shpg. wt., 6 oz. 60c

9 P 4880—Inside Chipper only. Shipping wt., 3 oz. 25c

### CRAFTSMAN

### 5 1/2-Inch Dado Saws

9 P 4888—Complete. 2 outside saws; 6 chippers. 1/2-in. hole. For saw shown on opposite page. Shpg. wt., 1 lb. 10 oz. \$3.50

9 P 4889—As above, but 3/4-in. hole for saws on Pages 4-5. Shpg. wt., 1 lb. 8 oz. \$3.50

On following items specify 1/2-inch hole for saw shown on opposite page, and 3/4-in. hole for saws shown on Pages 4 and 5.

9 P 4884—Outside Dado Saw only. Specify size. (See above.) Shpg. wt., 9 oz. 95c

9 P 4881—Inside Chipper only. Specify size. (See above.) Shpg. wt., 3 oz. 30c



## CRAFTSMAN and FULTON Circular Saws

**CRAFTSMAN SAWS**—Guaranteed America's finest quality. Made of special refined saw steel, properly tempered and hardened. Every saw carefully tested to make sure they are perfectly round and run absolutely true. Proper tension given by highly skilled saw makers makes the face smooth as glass and gives proper rigidity. Cut fast and easy in all woods. Expertly hand set and filed, ready for use. Highly polished—red etched.

**FULTON SAWS**—Made of high carbon saw steel, heat treated and hardened. Hand set and filed, ready for use. Well polished. Meets the demand for a better low priced saw. Really remarkable values at these low prices.

## Combination Saws

Handiest of all circular saws because they are specially designed for cross cutting, ripping or mitering. Really 3 saws in 1. CRAFTSMAN and FULTON flat ground saws are set and filed and cut fast and easy in all woods. CRAFTSMAN hollow ground saws run without set due to special grinding. They cut slightly slower than a flat ground saw but leave your work with an exceptionally smooth finish.

Diameter, Inches	Gauge	Center Hole, In.	Revolutions Per Minute	Shpg. Wt.	CRAFTSMAN		FULTON		FULTON Combination	CRAFTSMAN Combination	
					Cut-off 9 P 4927	Rip 9 P 4928	Cut-off 9 P 4923	Rip 9 P 4924	Flat Ground 9 P 4938	Flat Ground 9 P 4937	Hollow Ground 9 P 4939
6	18	1/2 or 3/8	4000	8 oz.	\$1.49	\$1.49	\$1.10	\$1.10	\$1.10	\$1.49	\$2.55
7	18	1/2 or 3/8	3500	12 oz.	.....	.....	.....	.....	1.29	1.85	2.95
8	17	1/2 or 3/8	3500	1 lb.	2.19	2.19	1.49	1.49	1.49	2.19	3.35
10	16	3/4 or 3/8	3500	1 lb. 10 oz.	2.75	2.75	.....	.....	1.85	2.75	4.35

We stock center hole sizes listed above but supply any size up to 2 inches without extra cost.

# CRAFTSMAN

REG. U.S. PAT. OFF.

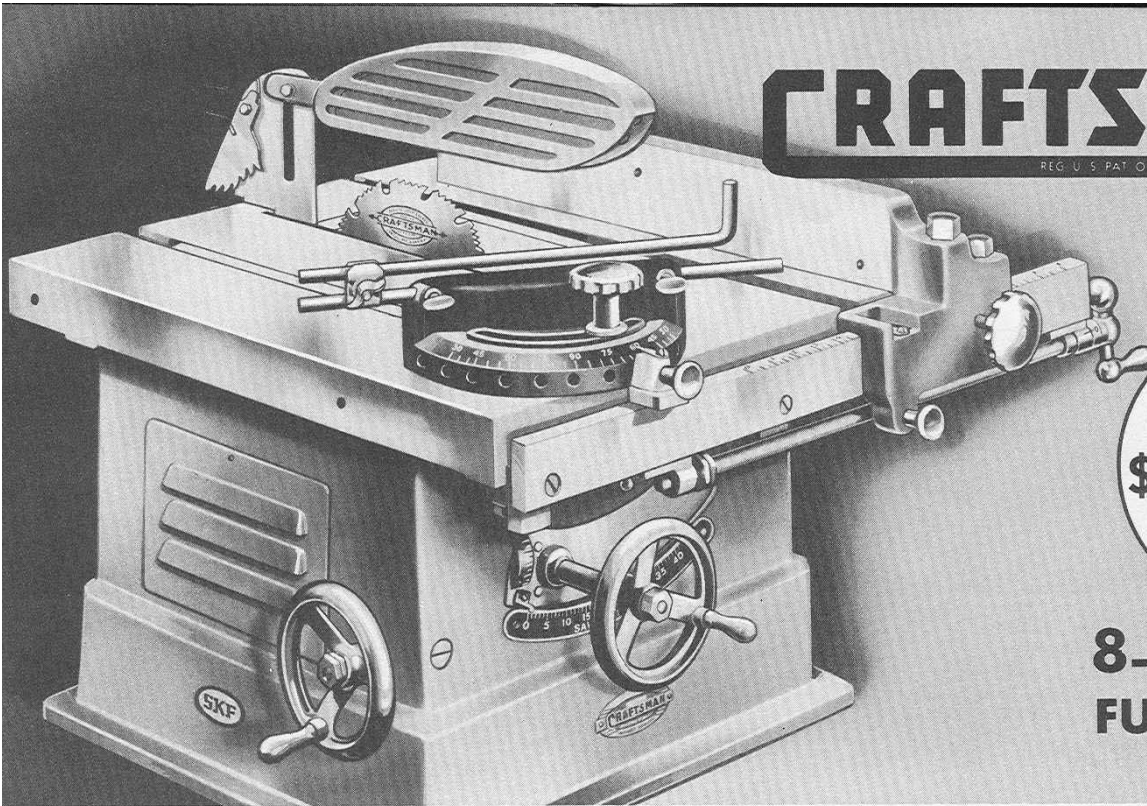

99 PM 2236

**\$34<sup>50</sup>**

**8-INCH BLADE  
FULL 2½-INCH  
CAPACITY**

**10-INCH BLADE . . FULL 3¼-INCH CAPACITY**

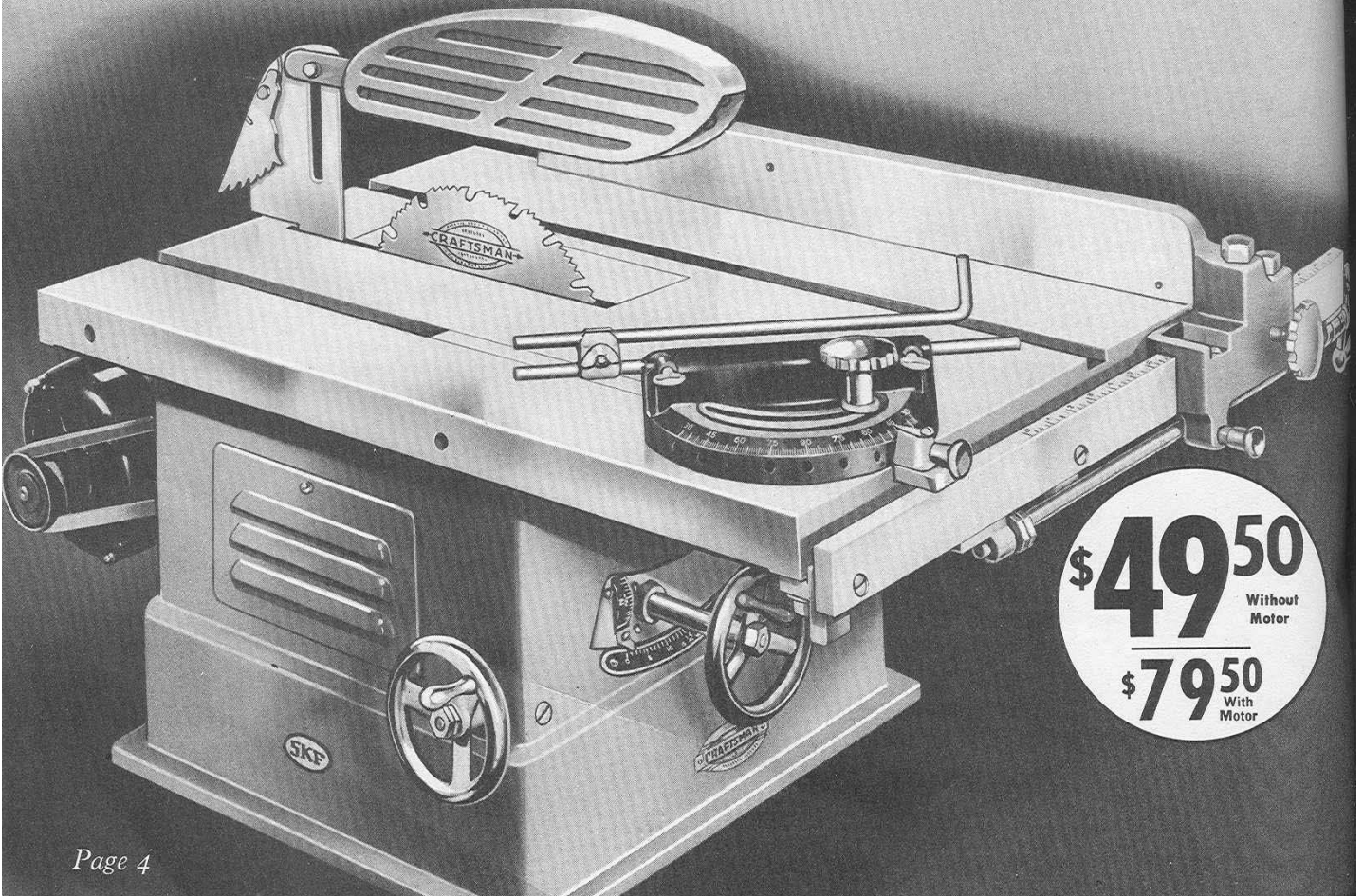

**\$49<sup>50</sup>** Without Motor  
**\$79<sup>50</sup>** With Motor

# HEAVY DUTY TILTING BLADE BENCH SAWS

## Lead the Field for Quality and Performance

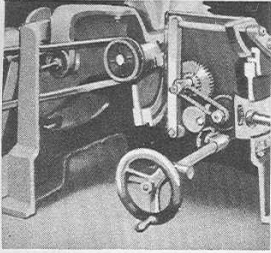

The elevating gears and rack are fully enclosed by two sheet steel sawdust guards. These have been removed in the illustration to show the arrangement of gears which accurately control the tilting mechanism.

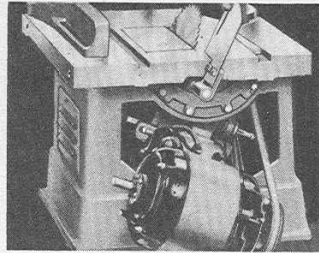

Massive runnions carry the entire tilting blade mechanism. This rugged construction assures real accuracy through many years of hard service. The motor is counterbalanced for ease in operation; it tilts, raises and lowers with saw blade and arbor.

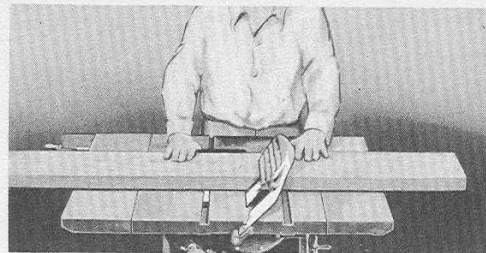

See how easy it is to cut a board at an angle on the CRAFTSMAN Tilting Blade Bench Saw. The table is never tilted, always level and easy to use. The work always lies flat regardless of the angle at which the board is being cut. That means no sliding—much easier operation! A long board which would hit the floor on a tilting table saw is easy to handle on the CRAFTSMAN.

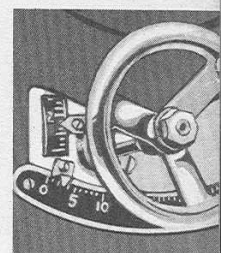

Drum type gauge gives exact depth of cut. Depth gauge moves with angular pointer.

- The saw blade tilts to any angle up to 45 degrees, and raises and lowers.
- Motor and blade tilt together as a unit. Belt always runs straight—is never twisted.
- Blade and arbor are carried in heavy cradle on large trunnions to insure stability.
- Angle and depth gauges mounted together—easily read regardless of position of blade.
- Rip fence feed screw control permits the adjustment of width of cut to 1/64 of an inch.
- Large precision-type SKF ball bearings.
- Elevating gears and rack are fully enclosed.

## THE CHOICE OF PROFESSIONAL CRAFTSMEN

These bench saws have made power tool history! With these saws Sears were the first to offer the advantages of tilting blade design to craftsmen everywhere at a reasonable price. And now with the experience gained from building these saws for several years, we have improved and perfected them to make them even more outstanding than ever before!

Our tilting blade design incorporates features that craftsmen have accepted as the best for years. With the conventional saw the table is tilted. It is difficult to hold the work in the correct position for sawing, as it tends to slide toward the lower side of the table. All this is eliminated in this better tool. Long boards which would touch the floor on a tilting table saw are handled as easily as short ones. Sawing on a tilting blade saw is ALWAYS faster—easier—better!

To build this type of saw—and build it right—required the resources of the largest distributor of power tools in the country. A tilting blade saw must be designed and built to the highest standards. Its construction requires the use of expensive special tools and machinery. The trunnions must be heavier—the base more rigid—the entire construction must be of the highest quality.

The improvements in the 1939 models include a sawdust guard for elevating gears and rack . . . a spring tension mounting of saw guard . . . a new motor base for easier and better adjustment . . . and a finer quality saw blade as standard equipment. The table is heavy and well ribbed—very smoothly ground to a fine finish. Very large diameter trunnions support a massive cradle, which tilts with the blade to provide angle cut. Angle of tilt is positively controlled by screw feed mechanism and large hand wheel. Saw blade and arbor are carried by an arm pivoted on cradle. This pivoted arm provides depth of cut adjustment and also carries the motor. Slide bolt under front of table locks both raising and tilting mechanisms easily and quickly. Rip fence is rigid self squaring type. Feed screw mechanism, for lead screw is readily engaged or disengaged; has vernier adjustment to 1/64-inch. The miter gauge is large, accurately made; indexed at 15 degree intervals, graduated at 1 degree intervals; fitted with adjustable stop rods. Blade is finest CRAFTSMAN quality combination crosscut and ripping type. Both 8 and 10-inch saws are covered by Patent No. 2,121,069.

### CRAFTSMAN 10-Inch Bench Saw

All the quality and features described above are included in this 10-inch CRAFTSMAN saw. Dimensions and specifications are given below.

#### SPECIFICATIONS

**TABLE:** 20x27 inches. With extensions added, as shown at right, 34x32 inches.  
**DEPTH OF CUT:** From 0 to 3 1/4 inches.  
**NET WEIGHT:** 150 pounds.  
**OVER-ALL DIMENSIONS:** Length, 30 inches; height, 20 inches; width, 28 inches.  
**RIP FENCE:** Fitted to bar graduated in 1/64ths from 0 to 15 inches.  
**BLADE:** 10-inch diameter, 5/8-inch bore.

99 PM 2237—CRAFTSMAN 10-inch Tilting Blade Bench Saw. With guard, rip fence, miter gauge, V belt and motor pulley. Without motor. Shipping weight, 200 pounds. . . . \$49.50  
 99 PM 2238—Same as above with 3/4-H.P. ball bearing double drive shaft repulsion-induction type motor, 99 PM 5611 described on Page 43. 110-volt, 60-cycle A.C. Shpg. wt., 245 lbs. \$79.50

### CRAFTSMAN 8-Inch Bench Saw

Compare it! We think you'll say it is the finest 8-inch bench saw you've ever seen. All the features discussed above are included. See specifications below.

#### SPECIFICATIONS

**TABLE:** 16x20 inches. With extensions added, as shown at right, 28x26 inches.  
**DEPTH OF CUT:** From 0 to 2 1/2 inches.  
**NET WEIGHT:** 130 pounds.  
**OVER-ALL DIMENSIONS:** Length, 26 inches; height, 17 inches; width, 26 inches.  
**RIP FENCE:** Fitted to bar graduated in 1/64ths from 0 to 11 inches.  
**BLADE:** 8-inch diameter, 5/8-inch bore.

99 PM 2236—CRAFTSMAN 8-inch Tilting Blade Bench Saw. With guard, rip fence, miter gauge, V belt and motor pulley. Without motor. Shipping weight, 150 lbs. . . . \$34.50  
 99 PM 2207—Same as above with 1/2-H.P. ball bearing double drive shaft capacitor type motor, 99 P 5587 described on Page 43. 110-volt, 60-cycle A.C. Shpg. wt., 185 lbs. \$49.50

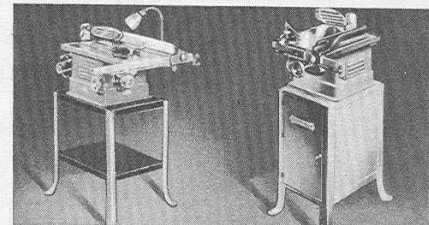

#### Machine Stand

Ideal for bench saws. Fully described on Page 40.  
 99 P 2746—Top, 16x21 in. Height, 31 in. For Bench Saw 99 PM 2236. Shpg. wt., 39 lbs. . . . \$5.65  
 99 P 2747—Top, 19x25 in. Height, 29 in. For Bench Saw 99 PM 2237. Shpg. wt., 46 lbs. . . . \$6.50

#### Machine Cabinet

Recommended for use with 99 PM 2236 Bench Saw. All steel. Roomy cabinet has sturdy shelf for tools. Top measures 16x21 inches. Stands 31 inches high. Complete description on Page 40. Shipping weight, 62 pounds.  
 99 PM 2718. . . . \$9.95



#### Heavy Duty Indexing Miter Gauge

Same as supplied on bench saws on this page. Fits 3/4 by 3/8-inch slot. Stops for different angles.  
 9 P 2252—Shpg. wt., 5 lbs. . . . \$2.60

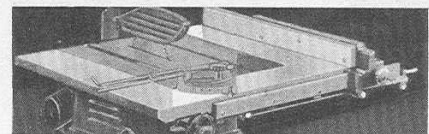

#### Extension Tables for Large Work

**Front Extension.** With all fittings and fine wood facing.  
 9 P 2208—For 99 PM 2236 Bench Saw. 6x16 in. Gives 15 in. in front of blade. Shpg. wt., 14 lbs. . . . \$4.50  
 9 P 2203—For 99 PM 2237 Bench Saw. 20x5 in. Gives 17 1/4 in. in front of blade. Shpg. wt., 14 lbs. . . . \$4.75  
**Side Extensions.** Usable only with front extensions above. Complete with long feed screw and graduated bar.  
 99 P 2209—For 99 PM 2236 Bench Saw. Each, 6x26 in. Shpg. wt., 37 lbs. 2 side extensions. . . . \$9.50  
 99 P 2204—For 99 PM 2237 Bench Saw. Each, 7x32 in. Shipping weight, 58 pounds. 2 side extensions. . . . \$11.50

#### Table Inserts for Dado Sawing

Insert is cut out to allow space for dado head.  
 9 P 2219—For 8-inch CRAFTSMAN Tilting Blade Bench Saw 99 PM 2236. Shpg. wt., 8 oz. . . . 75c  
 9 P 2201—For 10-inch CRAFTSMAN Tilting Blade Bench Saw 99 PM 2237. Shipping weight, 8 ounces. . . . 95c

# COMPANION

REG. U. S. PAT. OFF.

## DRAW CUT POWER HACK SAW

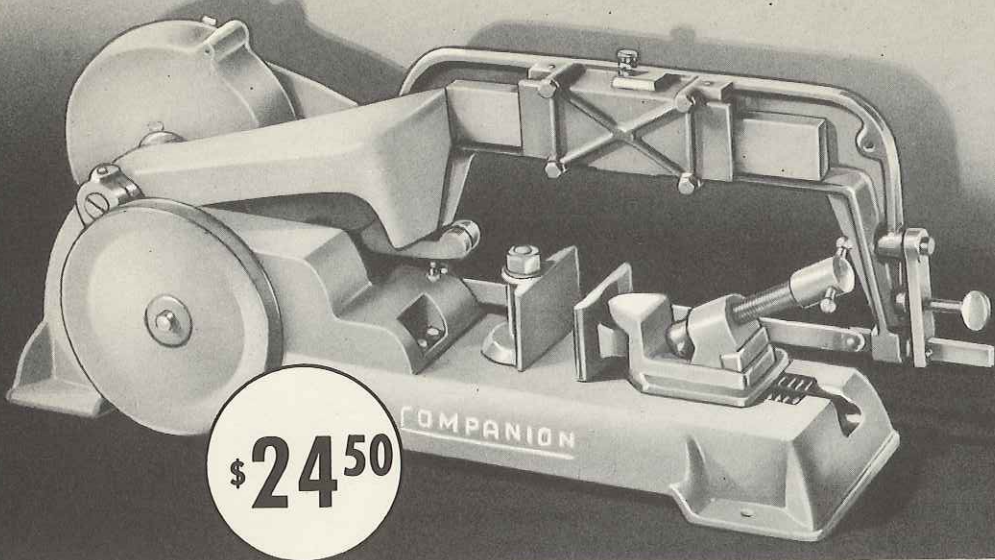

**\$24<sup>50</sup>**

- Heavy construction. Built to give years of reliable service.
- Finest quality, extra-large bronze bearings for longest life.
- Fully automatic in action. Completes job accurately without attention.
- Saw frame ruggedly constructed. Takes any standard power hack saw 12-in. blade.
- Draw cut. Lifting mechanism is provided to raise blade on back stroke.
- Easy to install work. Whole saw frame raises, leaving vise fully accessible.

### SPECIFICATIONS

- CAPACITY:** Takes materials such as iron, steel, brass or bakelite, etc., up to 4x4 inches.
- ANGLE OF CUT:** Vise adjustable to cut any angle from 90 degrees to 45 degrees.
- SAW FRAME:** Takes any standard 12-inch power hack saw blade. Raises out of the way when putting in new work.
- SAW FRAME GUIDE:** Heavy construction; frame is fitted with long life, ribbed, adjustable back plate.
- SAW FRAME BEARINGS:** Fitted with tapered adjusting screw to guarantee accurate saw alignment and true cutting of blade. Easily adjusted.
- GEARS:** Fine quality gray iron; accurately made, smooth running, enclosed by guard.
- BASE:** Large and sturdy. Fine quality gray iron, accurately machined. Built heavily for rigidity.
- BEARINGS:** Fine quality bronze; extra large for greater smoothness and longer life.
- WISE:** Stationary jaw has lock and swivel; movable jaw swivels to fit work and has quick action rack with lock.
- PRESSURE BAR:** Adjustable to different pressures for material being cut.
- ACTION:** Fully automatic draw cut; blade raises from the work on return stroke.
- LIFTING DEVICE:** Broad faced cam and lever mechanism combined with adjustable twin dogs and rack mechanism control lift of blade to produce a perfect draw stroke action.
- BLADE TENSIONER:** Screw and lever type; quick acting and accurate. Easy to adjust.

### The Finest Tool of Its Kind Ever Built

One of the BIGGEST work savers you ever laid eyes on—a hack saw that supplies its own pull! There has long been a great demand among factories, electricians, plumbers, and craftsmen of all kinds for a quality power hack saw at a moderate price. As a general rule the price of such a tool has been beyond the reach of the general user. By close cooperation with the manufacturer, careful design and thorough testing we have produced a really practical shop tool, built for long life, selling at a surprisingly low price.

This power hack saw is fully automatic in action; permits you to do other work while it finishes its job unattended, and with a high degree of accuracy. It is a draw cut machine with an automatic relieving mechanism. The blade lifts from the work on the return stroke, increasing blade life and efficiency.

High quality materials and workmanship have been used in every detail of construction. Check the features and specifications carefully. See for yourself why we say this saw can be compared only with those selling for several times its price! Shpg. wt., 80 lbs.

- 99 PM 2294—Power Hack Saw**.....\$24.50
- 9 P 6580—CRAFTSMAN 12-inch Power Blades.** 14 teeth to the inch. 5/8 inch wide. .032 inch thick. Shipping weight, 1 pound 2 ounces. Dozen.....95c

Easy Terms  
ON ORDERS OF  
120 OR MORE  
SEE INSIDE  
FRONT COVER

## CRAFTSMAN Professional WELDING OUTFITS

REG. U. S. PAT. OFF.

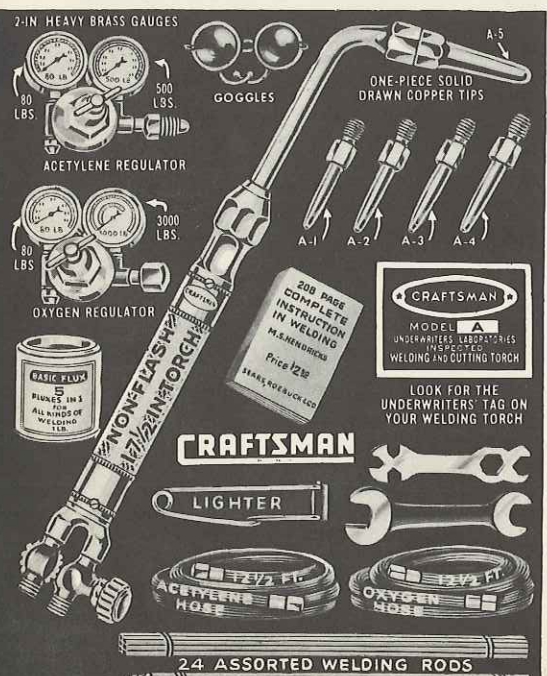

**\$44<sup>95</sup>**

**Complete**  
Positively no other equipment equal in quality at anywhere near Sears price. Thousands now in use. Safe, and absolutely dependable. For welding sheet metal, heavy automotive, tractor or farm machine repairs. Consists of heavy duty 17 1/2-inch perfectly balanced non-flash torch with 5 solid drawn copper welding tips; all-brass double gauge oxygen and acetylene regulators; two 12 1/2-foot lengths of heavy duty corrugated hose with connections; lighter; goggles; 24 assorted welding rods; flux for all kinds of welding and a 208-page Welder's Manual worth \$2.50! Unit may also be used as a cutting torch with attachment shown at right. Shipping weight, 28 pounds.  
**99 P 5442—CRAFTSMAN Welding Outfit complete as illustrated. \$44.95**

- ### Parts and Accessories for CRAFTSMAN Welding Outfit
- Model A Welding Torch.** 17 1/2-in. heavy duty solid brass. With 6-in. mixer. Will cut steel with attachment listed at right. \$14.25  
**9 P 5429—Shpg. wt., 3 lbs.**.....\$14.25
- Oxygen and Acetylene High Pressure Welding Hose.** 1/4-inch. Swivel connection. Shipping weight, 12 1/2-foot, 1 lb. 13 oz.; 25-foot, 4 lbs.  
**9 P 5437—Oxygen Hose.** 12 1/2-ft. .... \$2.50; 25-ft. .... \$3.75  
**9 P 5438—Acetylene Hose.** 12 1/2-ft. .... \$2.50; 25-ft. .... 3.75
- 90 Assorted Welding Rods.** Consists of bronze aluminum, iron and mild steel. Size, 3/8 to 1/4-inch; lengths 18 to 24 inch. Handy assortment for garage or welding shop. \$2.75  
**9 P 5440—Shipping weight, 11 pounds.**.....\$2.75
- Oxygen and Acetylene Regulators.** Gauges are all forged brass fitted with 2-inch beveled glass. Shipping weight, each, 4 pounds.  
**9 P 5430—Oxygen Regulators with 80 and 3,000-lb. gauges.**..... \$14.25  
**9 P 5431—Acetylene Regulator with 80 and 500-lb. gauges.**.....\$12.25
- Welding Tips.** One-piece solid drawn pure copper. Leakproof. Sizes: A-0 for radiator repairing; A-1 for fender welding; A-2, A-3, A-4, A-5, A-6, A-7, and A-8 for welding metals up to 1 1/2 in. thick. State size.  
**9 P 5441—Shipping weight, 4 ounces. Each** .....\$1.50
- 12-in. Mixing Chamber.** Necessary for use with tips, A-6, A-7, or A-8.  
**9 P 5443—Shipping weight, 12 ounces.**.....\$4.75



**CRAFTSMAN Cutting Attachment**  
Connect it to welding torch in place of mixer. With wrench and No. B-3 tip. Cuts steel up to 1 1/2 inches thick. Cuts up to 6-inch steel with larger tips. Shipping weight, 3 lbs. 6 oz.  
**9 P 5444.....\$14.75**



**CRAFTSMAN Jr. Soldering Outfit**  
Use with Prest-O-Lite cylinders to burn paint, braze, solder, etc. Handle, 3 heating tips, soldering copper, paint burning tip, tank connections, tip cleaner, 5 feet of rubber hose and instructions. Shipping weight, 2 pounds.  
**9 P 5446.....\$5.85**

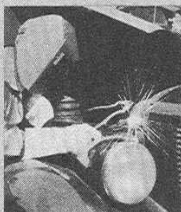

**Garages**  
To weld cracked motor blocks, fenders, body metal, steel wheels, etc.

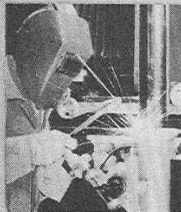

**Manufacturing Plants**  
Very useful for making dies, tools, jigs, fixtures, work benches, etc.

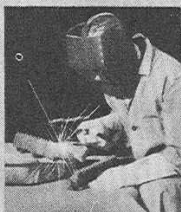

**Home Workshops**  
For building models, inventions, and dozens of things for the home.

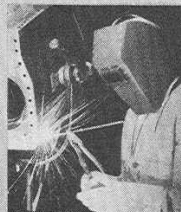

**Farm Machinery**  
For repairing farm machinery of all kinds—plows, tractors, etc.

**\$42<sup>50</sup>**  
Complete

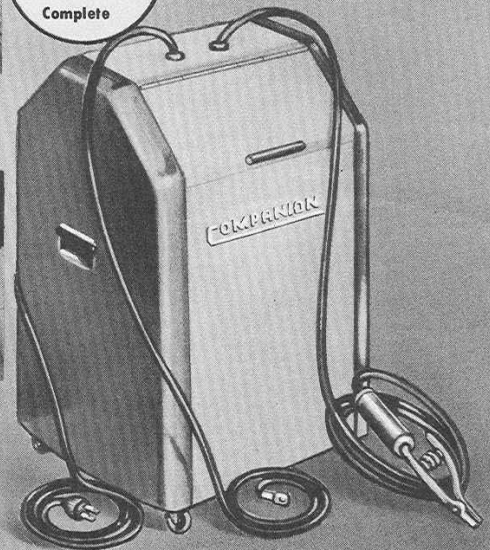

## CRAFTSMAN

### Glass Insulated ARC WELDER

- Coils are made of highest grade copper magnet wire insulated with PURE GLASS FABRIC.
- Glass fabric insulation resists temperature as high as 500° Fahrenheit . . . practically eliminates burning out of coils.
- 160-amp. maximum capacity with 6 taps for different work.
- Built for professional use and for continuous service.

If you want the best in A.C. electric welding equipment—if you weld all thicknesses of metals—if you weld for long periods at a time—the CRAFTSMAN is the welder for you! Bigger! Heavier! Actually compares with welders selling for up to \$150.00! So simple to operate that no experience is necessary. *The use of the new glass fabric insulated wire is one of the greatest advancements EVER made in welder design!* This new insulation actually looks like rayon, but is woven from pure glass. Think of having a welder that resists temperatures as high as 500° Fahrenheit! No danger of burning out coils when operating on high heat! As long as you use it on the correct current supply (220 volts A.C.) it is almost impossible to harm the machine. Wide range of heats—160, 120, 90, 60, 40 and 20 amperes of actual welding current. Handles all work from heavy castings and structural steel down to light metals like fenders, sheet metals, etc. Cuts iron, steel, or cast iron up to 3/16 in. thick. Will do brazing or soldering. Uses rods from 1/16 to 3/32 in. Melts 3/32-in. rods at a rate of 450 in. per hour.

New type Bakelite selector plug and control panel make it easy to change from one welding heat to another INSTANTLY. Enclosed Bakelite control panel. Cabinet is 18x18 in.; 32 1/2 in. high. Operates on 220-volt, 60-cycle, single-phase, alternating current only. Includes two 10-foot welding cables, electrode holder, extension cord, welder's helmet, supply of welding rods, carbon electrode for brazing, soldering and cutting, and instructions.

99 PM 2001—Shipping weight, 155 pounds . . . . . \$87.50

### Shielded Welding Rods \$129

These welding rods are intended particularly for A.C. arc welders. Also may be used on D.C. welders. They are covered with a heavy coating of flux. The flux cleans the surface of the metal and also protects the surface of work being welded. At the intensely high temperature of the arc oxides will form on the molten metal and may be included in the weld if an effective flux is not used. Flux also allows the weld to cool more slowly. Recommended for general purpose work on cast iron and steel. Shipping weight, 5 pounds 12 ounces.

9 P 2003—Specify size wanted.  
Size . . . . . 1/8 in. . . . . 3/16 in. . . . . 1/4 in. . . . . 5/16 in.  
5-lb. package . . . . . \$1.98 . . . . . \$1.69 . . . . . \$1.39 . . . . . \$1.29

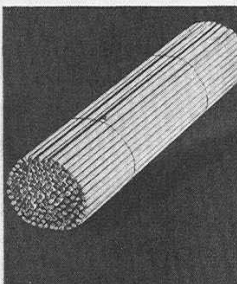

## COMPANION

### Utility ARC WELDER

- Will melt 300 inches of 1/8-in. welding rod per hour.
- Operates on 110-volt, or 220-volt, 60-cycle A.C.
- Plugs in to socket. . . . Uses standard 30-ampere fuse.
- Has 4-heat control taps; proper heat for every job.
- Easily movable on heavy steel casters; machine is entirely enclosed for greater safety and durability.

Do your own arc welding—and save money! The COMPANION Arc Welder is the ideal machine for repair and maintenance jobs. With it, you can weld automobile engine blocks, axles, frames, farm machinery, tanks, etc. Usually earns its cost on first few jobs. Very easy to operate. No experience necessary.

Operates on 110-volt or 220-volt, 60-cycle, single phase, alternating current. Also operates on one phase of a three-phase current supply. Uses welding rods from 1/16 inch to 1/8 inch diameter, and cuts metal up to 1/8 inch thick. Four heat control taps—heat range from 25 to 80 amperes on 110 volts A.C. and 55 to 120 amperes on 220 volts A.C. Transformer and variable reactance entirely enclosed for maximum safety. Welds iron, steel, cast iron, cast steel, etc. Brazes other metals like brass, copper, bronze, etc. Also may be used for soldering and light cutting. Not recommended for steady production use, but ideal for general purpose intermittent service where the machine may be allowed to cool off periodically. Period of continuous operation varies with heat tap used. Includes two ten-foot welding cables, high quality electrode holder, extension wiring, welders helmet, supply of welding rods, carbon electrode for brazing, soldering and cutting, and simple operating instructions.

**Easy Terms!**  
ON ORDERS OF \$20 OR MORE - SEE INSIDE FRONT COVER

99 PM 2007—Shipping weight, 125 pounds . . . . . \$42.50

### Welding Helmet \$319

An absolute necessity for the welding operator in order to protect him against sparks and shield his eyes from the brilliant light. You should never get close to a welder without the protection of a helmet. Strongly made. Adjustable to any angle or to different sizes of head. May be thrown back out of way without removing from head. The eye shield has two layers of glass. The outer layer is made of ordinary inexpensive glass which protects the more expensive colored glass on the inside.

9 P 2009—Shpg. wt., 14 oz. . . . . \$3.19

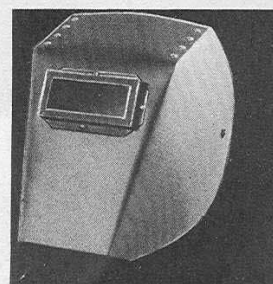

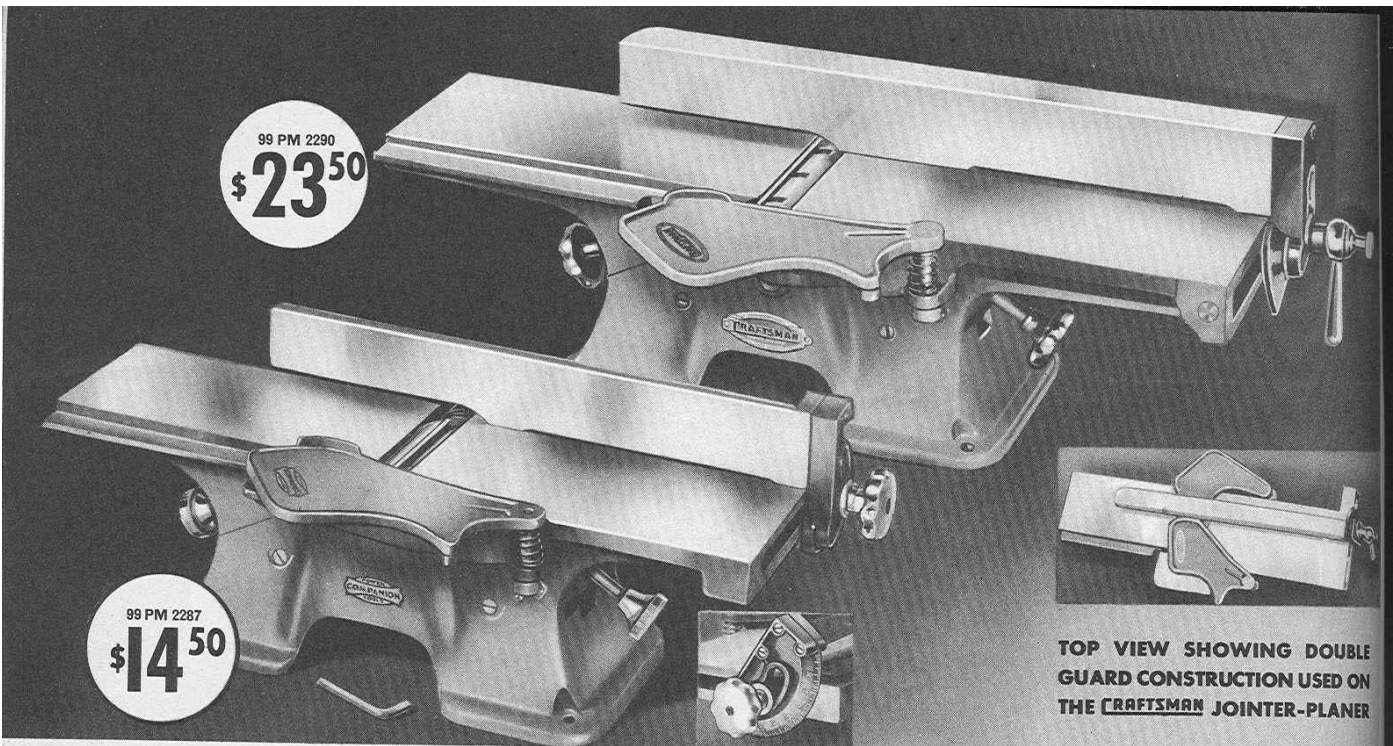

99 PM 2290  
\$23<sup>50</sup>

99 PM 2287  
\$14<sup>50</sup>

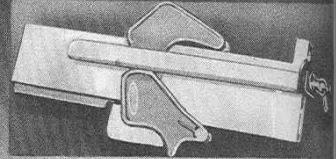

TOP VIEW SHOWING DOUBLE GUARD CONSTRUCTION USED ON THE CRAFTSMAN JOINTER-PLANER

**COMPANION** BRONZE BEARING

**4 1/4-In. JOINTER-PLANER**

- Large SOLID STEEL 4 1/4-in. cutter head. Carefully balanced for smoothness at high speeds. (We know of no other jointer for less than \$20.00 which has a solid steel head.)
- Three high-speed steel cutters retain their sharp, easy cutting qualities for long periods. Locked in place with gib plates and set screws tapped through the head itself.
- Fitted with auto-lubricating bronze bearings.
- Tables are finish ground after assembly on base to insure absolute accuracy.
- Micromatic control for depth of cut with accurate scale for easy, quick adjustment.
- Finely graduated scale on fence for angle cuts (see inset).

This jointer-planer gives woodworkers a greater degree of accuracy and safety than any similar tool offered anywhere near this price. Do not confuse this sturdy 4 1/4-in. machine with lighter 4-in. tools. The solid steel cutter head itself is enough to convince the experienced craftsman that this is a quality tool.

The tables are ground after assembly and operate on accurately machined ways that insure perfect relationship of both tables for all depths of cut. Total length of tables, 21 3/8 inches. Guard need never be removed even for rabbeting. Can easily be lowered and swung under the rabbeting ledge out of the way. Both front and rear tables are fully adjustable. The fine quality auto-lubricating bronze bearings are unusually large so as to provide long life. New fence regulating mechanism permits quick adjustments for angle cuts. Oversize 4 1/4-inch steel cutter head easily handles 4-inch lumber in the rough. Net weight, 38 pounds. 99 PM 2287—Shipping weight, 44 pounds. . . . \$14.50

**CRAFTSMAN** BALL BEARING

**4 1/4-In. JOINTER-PLANER**

- Solid steel 4 1/4-in. cutter head runs in accurately fitted SKF ball bearings that are fully enclosed.
- Extra long tables give better support to work. Full 26 in. long over all—for greater accuracy—finer work.
- Two guards—one on each side of fence—keep the cutter head covered regardless of position of fence. This means greater safety for the operator at all times.
- Improved fence design—position and angle adjustment are accurate and operate independently of each other.
- Rugged gray iron frame is carefully designed, machined, finely finished, and exceptionally strong and rigid.
- Three high-speed steel cutters keep their keen edges for surprisingly long periods under the hardest use.
- Depth of cut easily adjusted and shown on accurate scale. Both tables easily adjustable.
- Guard can be lowered and swung under rabbeting ledge.

This jointer-planer is made for the craftsman who wants top-notch quality—accuracy—and convenience of adjustments. Has all the features of the COMPANION jointer-planer shown at left plus ball bearing construction, much longer tables, improved fence and double guards. The fine precision ball bearing construction means smoother operation and longer life. The tables are longer than we have ever offered in a 4 1/4-in. jointer. Full 26 in. over all. The double guard provides a guard on each side of the fence. The cutter head is always covered, regardless of fence position. This means maximum safety at all times. The entire fence and tilting mechanism may be moved sideways across the table without affecting the angle. Carefully ground tables slide on ways that are machined to close limits for permanent accuracy.

CRAFTSMAN engineers and CRAFTSMAN manufacturers agree that the most important single characteristic of a jointer is accuracy. In the finely ground table, steel cutter head, precision ball bearing, and many other features you will find their answer to the demand for accuracy. We believe you will find this jointer a very accurate tool and a fine addition to your shop. Over-all length, 26 in. Width, 9 1/2 in. Height, 8 1/2 in. Shipping weight, 51 pounds. 99 PM 2290—Without motor . . . . \$23.50 99 PM 2293—Same as above but with COMPANION 1/2-H.P. 110-volt 60-cycle ball bearing motor No. 99 P 5607 shown on Page 43. Shipping weight, 81 pounds. . . . \$33.00

Easy Terms ON ORDERS OF 20 OR MORE SEE INSIDE FRONT COVER

**COMPANION Machine Stand**

Rugged 12-gauge steel. Top and shelf strongly secured to legs. Legs provided with holes for moving height of top or motor shelf. Top and shelf finished in lustrous black; legs in royal blue. Packed flat for shipping. Size of top, 10x21 in. Height, 31 inches. Shipping weight, 33 pounds. 99 P 2744 . . . . \$4.85

**COMPANION Tool Light**

The 15-inch flexible neck lets you bring the light down to your work just where you want it. New type adjustable clamp. Extra large reflector keeps the light out of your eyes—a real safety feature. Better light enables you to do better work. Over-all length, 23 inches. Complete with push switch in socket, clamp, cord and plug. Shipping weight, 1 pound 12 ounces. 9 P 2264 . . . . \$1.60

Page 8

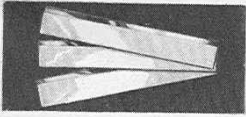
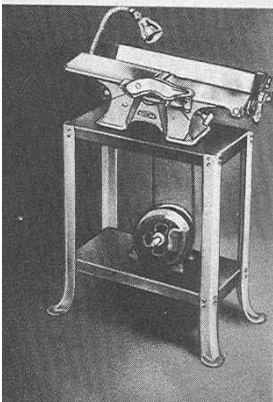

**4 1/4-Inch Jointer Knives**

High speed tool steel blades that are ground to a keen edge—and hold it! Finest quality! Set of three for either of the jointers on this page. Shipping weight, 7 ounces. 9 P 2291 . . . . \$2.10

\$43<sup>50</sup>

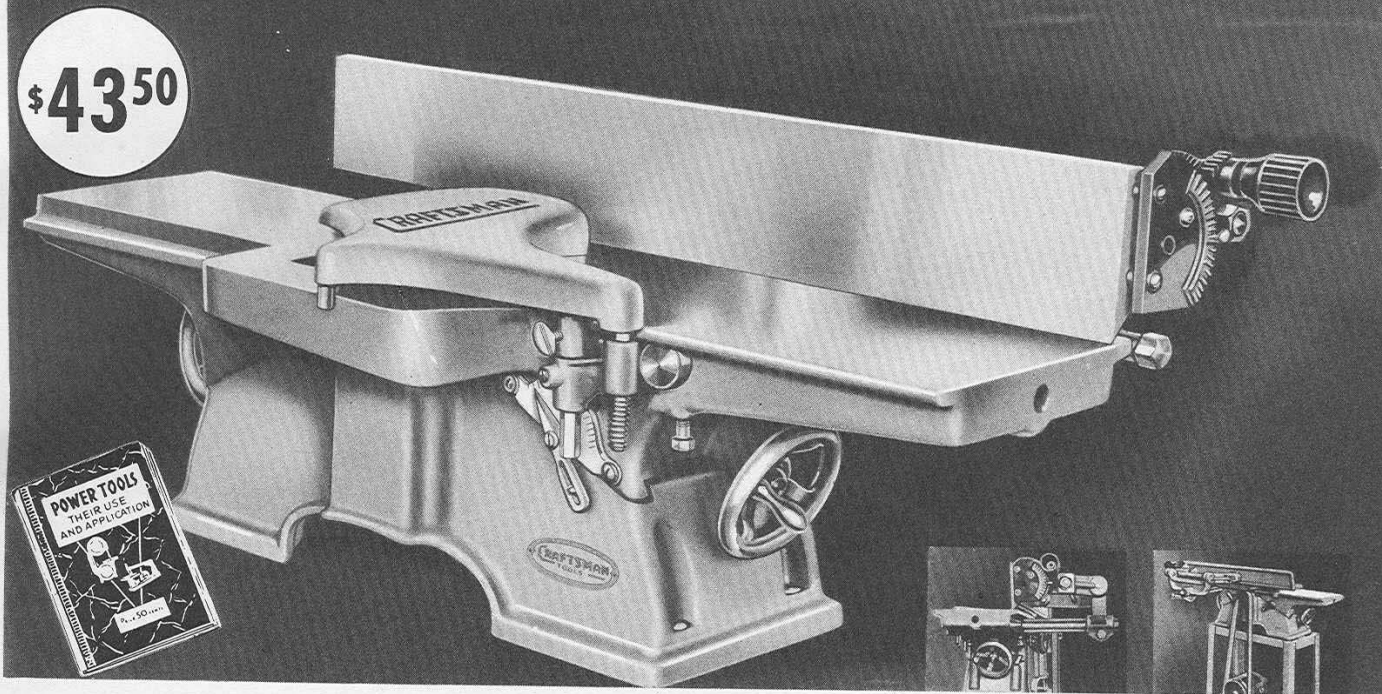

# CRAFTSMAN

REG. U. S. PAT. OFF.

## 6-INCH HEAVY DUTY JOINTER-PLANER

- Heavy SKF ball bearings enclosed in dustproof housings for long service.
- Solid steel cutter head, 2½ inches in diameter, full 6 inches wide. Equipped with 3 high speed steel knives.
- Full 5/8-inch diameter steel shaft.
- Maximum depth of cut, 5/8-inch.
- Extra long tables, 37 inches over all.
- Tables accurately ground for perfect alignment; move on dovetailed ways.
- Accurate heavy gray iron frame.
- Equipped with geared-type tilting fence. Large, quick-acting guard. Accurate depth of cut scale.

High speed! Heavy duty! One of the finest and most accurate power tools of its kind that money can buy! The rugged, carefully ground tables are controlled by conveniently located hand wheels and slide on dovetailed ways for permanent accuracy. The cutter head is made of solid steel, 6 inches long, 2½ inches in diameter, with knife slots ground in the shape of inverted wedges, to assure accurate and positive locking of knives. The fence is 28 inches long and 4 inches high. It can be moved as a unit across table without changing its angle. The efficient guard keeps cutter head covered and need never be removed, even for rabbeting. Protractor gauge indicates depth of cut at all times. The movement of table is magnified by pointer, thus insuring accuracy. Over-all dimensions: length, 37 in.; height, 13 in.; width, 13 in. Shipping weight, 160 pounds.

99 PM 2288—CRAFTSMAN 6-Inch Heavy Duty Jointer-Planer complete with geared fence, high speed steel knives, pulley, motor pulley, belt and 72-page instruction book. Without motor.....\$43.50

99 PM 2295—Same as above with 99 P 5587 ½-H. P. Condenser Motor shown on Page 43. Shipping weight, 195 pounds.....\$59.50

JOINTER KNIVES—Made of finest quality high speed tool steel. Hold keen edge longer than most knives. Set of 3 for jointer-planer 99 PM 2288. Shpg. wt., 4 oz. 99 P 2292.....\$3.35

Easy Terms! ON ORDERS OF \$20 OR MORE SEE INSIDE FRONT COVER

MACHINE STAND—For jointer-planer 99 PM 2288. Strong and rigid. Has 10x34-in. top height, 31 in. See Page 40 for detailed description. Shipping wt., 36 lbs. 99 P 2745.....\$5.75

# CRAFTSMAN THICKNESS PLANER

## 4-INCH BY 12-INCH CAPACITY

- Precision New Departure ball bearings.
- Feed rolls machined from solid steel.
- 3¼-inch diameter steel cutter head.
- Frame is heavy, well ribbed one-piece casting.
- Graduated scale shows depth of cut.
- Gibs provided to assure accurate alignment of table to head.
- Table is heavily ribbed, accurately planed one-piece casting.
- Chip breaker and pressure bar completely guard head and feed rolls.

Here's REAL quality—SUPER QUALITY! Not a jointer—but a regular thickness planer that easily handles big production jobs as well as small and delicate work. Heavy duty construction. A dependable woodworking machine designed for production work in shops and mills.

Will plane material up to 12 in. wide and 4 in. thick—and as small as 6 in. long and 1/16 in. thick. Table is fitted to main frame by machined ways. Adjustment for depth of cut made with convenient hand wheel. Front infeed roll is fluted to insure positive feed. Gear box is equipped with cut gears fully lubricated for a lifetime of service. Pressure rolls have compression springs, conveniently adjusted. Safety-type cutter head, 3¼ inches in diameter, is fitted with 3 high-speed knives. Motor requirements vary from 1/2 to 2 H.P. depending on depth and width of cut, kind of wood, etc. Shipped from factory in Southern Ohio and you pay freight from there.

99 PM 2349—Shipping weight, 290 pounds.....\$179.50

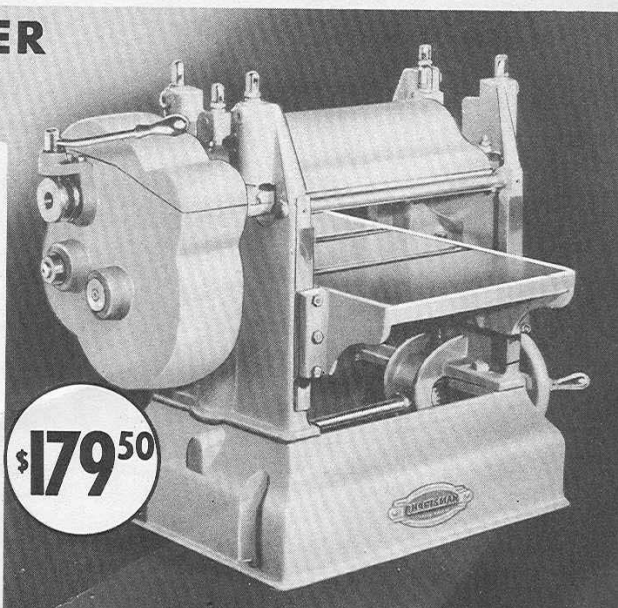

\$179<sup>50</sup>

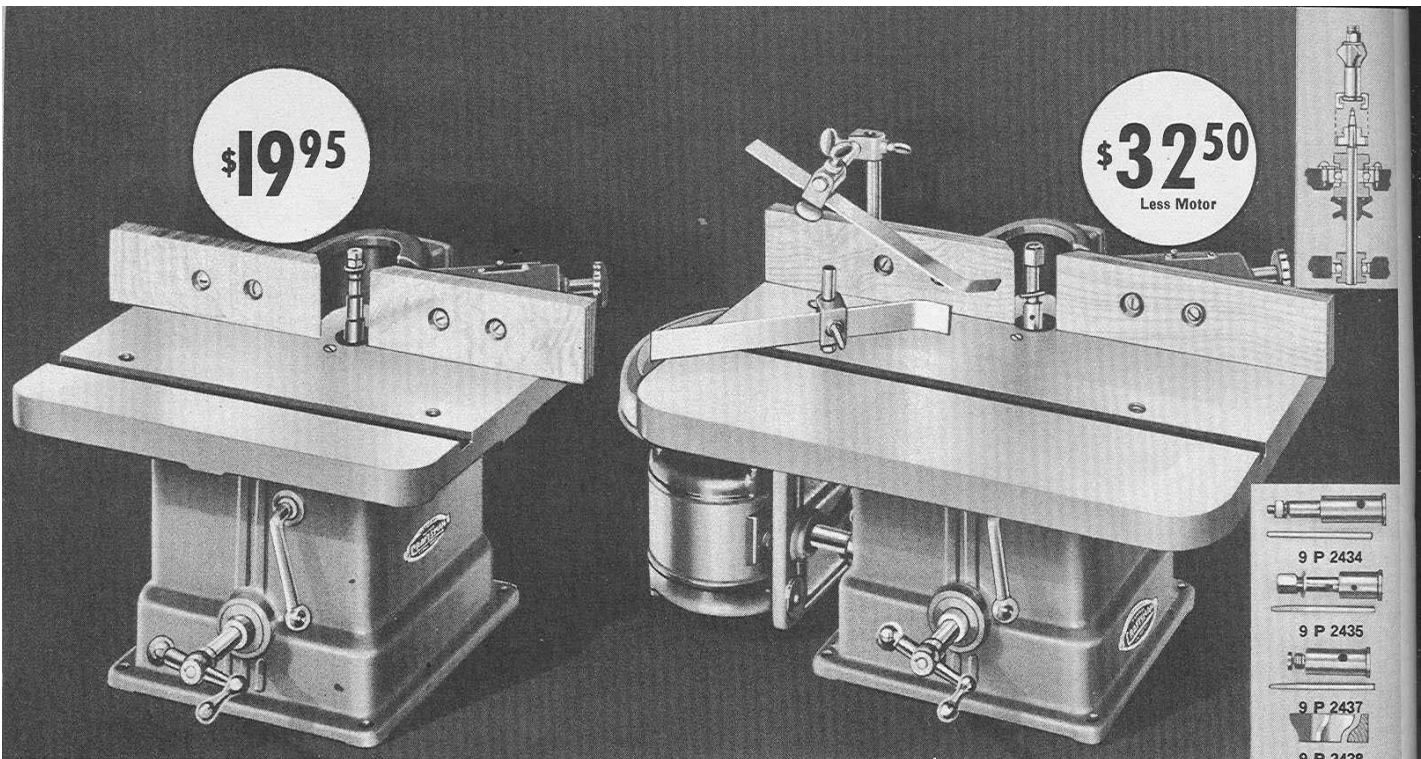

# CRAFTSMAN SHAPERS .. SKF BALL BEARINGS

- Fixed spindle design. No need to remove or invert spindle.
- Bevel gears accurately raise or lower table for adjusting cut.
- Extra-large deep groove SKF ball bearings for smooth operation.
- 3/4-inch diameter ground steel spindle.
- Design of shaper fence provides maximum safety for operator.
- Fence depth scale is graduated from 0 to 1/2 inch in 1/16 divisions.

- CRAFTSMAN De Luxe. All features of shaper shown at left, but bigger and heavier and with the additional features shown below.
- New tapered spindle makes tool much more versatile.
- Gray iron guard covers motor pulley and belt; keeps out sawdust.
- Much larger table for easier operation. Size, 15x21 inches.
- Rugged, built-in motor mount and spring hold-downs included.

Any shaper must be capable of operating at very high speeds if it is to cut smoothly and rapidly at all possible angles to the grain of the wood. In the CRAFTSMAN shapers instead of the spindle and bearings moving to adjust the cutter height the table moves up and down, thus allowing the spindle and bearing assembly to be mounted solidly in the frame. Mounting the bearings directly in the frame means that they are more solidly mounted. Moreover they are backed up by a large mass of gray iron which will rapidly carry away any heat which may develop from the normal operation of these bearings at high speeds. The CRAFTSMAN shapers will actually turn 12,000 R.P.M. smoothly and easily.

Table is raised and lowered by means of gears and raising screw. A 2 3/4-inch diameter column carries table in its vertical movement and a smaller rod prevents side movement. Large, coordinate type wedges lock table in any position. Table has slot for miter gauge, and tapped holes for starting pins and hold-down studs. Table insert is removable for drum sanding. One side of fence may be moved in or out for jointing operations. Screw feed is controlled by a convenient hand knob. May be locked in any desired position. Graduated scale shows depth of cut.

**Specifications:** Table size, 11x15 in. Spindle speed, using 3450 R.P.M. motor, 9200 R.P.M. Spindle diameter, 3/4 in. 2-step spindle for 1/2 or 3/16-in. bore cutters. 2 heavy duty 3/4-in. bore SKF ball bearings. Table travel, 2 in. Over all length of fence, 23 in. Over all dimensions: minimum height, 14 in.; maximum height, 16 in.; width, 16 in.; length, less motor, 23 in. With belt and motor pulley. Motor required, 1/2-H.P. 3450 R.P.M., ball bearing. See Page 43. Shpg. wt., 75 lbs.  
**99 PM 2308—CRAFTSMAN Shaper.....\$19.95**

## COMPANION Machine Stand

Mount your shaper on this sturdy, all-metal stand. Extremely strong and rigid. Top, 10x21 in.; 31 in. high. For complete description see Page 40.  
**99 P 2744—Shipping weight, 33 pounds.....\$4.85**

The finest tool of its kind! Big—sturdy—accurate—dependable! Has ALL the features of the shaper at left, but IN ADDITION it is bigger and heavier with many extra features and improvements. Has the same fixed spindle construction for smoother, faster, more accurate performance.

The new tapered spindle is an important development this year. It's similar to that used on our large drill presses. See small insert cut above large shaper. Spindle is tapered to take any one of three different adapters listed below. Adapter mounts on spindle and is locked in place by knurled collar. With this construction you can handle a wide variety of cutters, yet the cutter is always quite close to the upper bearing. This insures smooth, vibrationless operation. The gray iron guard covers motor pulley and belt and prevents sawdust from falling into motor. Supplied with 1/2-inch adapter 9 P 2435 listed below. Other adapters may be purchased as desired.

**Specifications:** Table size, 15x21 in. Spindle speed, using 3450 R.P.M. motor, 9200 R.P.M. Spindle diameter, 3/4-inch. Bearings, 2 heavy duty 3/4-in. bore SKF ball bearings. Table travel, 2 in. Over all length of fence, 23 in. Over all dimensions: minimum height, 16 in.; maximum height, 18 in.; width, 16 in.; length with motor, 28 in. Motor required, 1/2-H.P. 3450 R.P.M., ball bearing (see Page 43).  
**99 PM 2309—With 32-in. belt and 4-in. motor pulley, motor mounting and hold-downs, less motor. Shipping weight, 105 pounds.....\$32.50**

**Adapters for CRAFTSMAN De Luxe Shaper.** Also fit CRAFTSMAN drill presses. Not for CRAFTSMAN Shaper at left. To mount adapter on the tapered spindle, the knurled collar is removed and the adapter is placed on the spindle. Then the collar is replaced and locks the adapter in place.  
**9 P 2434—Adapter for 3/16-in. bore cutters. Shpg. wt., 6 oz.....\$1.25**  
**9 P 2435—Adapter for 1/2-in. bore cutters. Shpg. wt., 7 oz......95**  
**9 P 2437—Adapter for sash cutter below. Shpg. wt., 6 oz..... 1.25**  
**Sash Cutter.** To be used on the CRAFTSMAN DeLuxe Shaper with the adapter 9 P 2437 listed above. Shipping weight, 4 ounces.  
**9 P 2438—Sash Cutter.....\$1.45**

Easy Terms!  
 ON ORDERS OF \$20 OR MORE  
 SEE INSIDE FRONT COVER

## LOWEST PRICES ON FINE QUALITY SHAPERS, CUTTERS AND COLLARS

### Cutters in Top Two Rows Fit 1/2-Inch Spindles



**9 P 2319 85c**    **9 P 2321 85c**    **9 P 2323 95c**    **9 P 2325 95c**    **9 P 2327 95c**    **9 P 2329 95c**    **9 P 2331 95c**    **9 P 2333 95c**    **9 P 2335 95c**    **9 P 2365—Tongue and groove. Shpg. wt., 10 oz.....\$1.85**



**9 P 2345—Large size. Blades about 3/8 inch longer than above.....\$1.60**    **9 P 2346—Large size. Blades about 3/8 inch longer than above.....\$1.60**    **9 P 2347—Large size. Blades about 3/8 inch longer than above.....\$1.60**    **9 P 2348—Large size. Blades about 3/8 inch longer than above.....\$1.60**



**9 P 2340 Fits 3/16-in. spindle 59c**    **9 P 2342 Fits 3/16-in. spindle 59c**    **9 P 2344 Fits 3/16-in. spindle 59c**    **9 P 2350 Fits 3/16-in. spindle 59c**    **9 P 2354 Fits 3/16-in. spindle 59c**    **9 P 2356 Fits 3/16-in. spindle 59c**    **9 P 2359 Fits 3/16-in. spindle 59c**    **9 P 2362 Fits 3/16-in. spindle 59c**    **9 P 2367 Shaper collars. Fit 1/2-inch spindle \$1.29**    **9 P 2368 Shaper collars. Fit 3/16-inch spindle .39c**    **9 P 2465 Cutter lock nut. Fits 1/2-in. spindle. Shpg. wt., 1 oz 7c**

Shipping weight, collars and cutters, 4 ounces each unless otherwise specified.

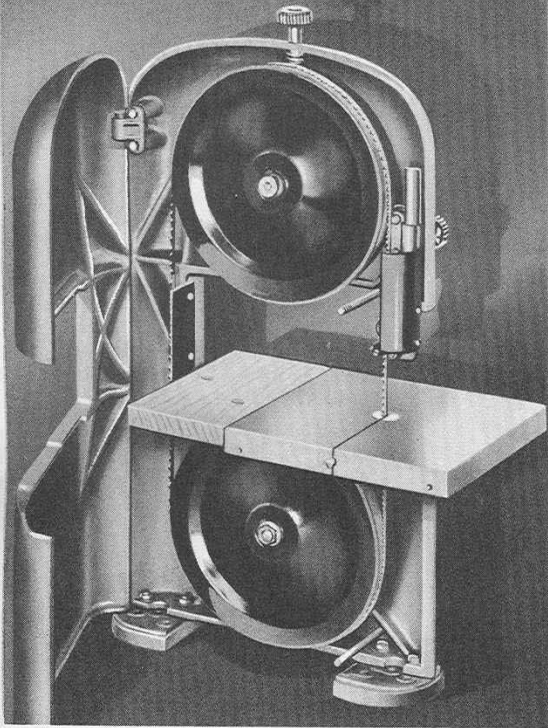

# CRAFTSMAN

## IO-INCH BAND SAW FULLY ENCLOSED

### EXCLUSIVE SEARS DEVELOPMENT

This sensational band saw has features and operating advantages you'll find in no other band saw in the world—REGARDLESS OF PRICE! Just notice Sears exclusive enclosed design! It gives the saw a beautiful sleek and streamlined appearance—but far more important, it makes it one of the safest band saws ever placed on the market. So fully enclosed that the only visible operating part is a pulley on the back side. Even the blade itself is enclosed by an auxiliary guard that moves up and down with the guide and thrust assembly so that only the actual cutting portion of the blade is exposed. The wheels are completely covered—and if the blade breaks, it's inside the casing where it can't get out.

This enclosed type of construction also means that you get a much bigger and heavier saw. It's built like large production machine tools. The 10-inch wheels are set in a frame almost big enough for a 12-inch machine. Notice the shipping weight below! This heavier construction means MUCH more smoothness and stability in operation.

The 1/4-inch, high quality steel blade is 63 inches long to permit cutting a full 4 1/4-inch depth instead of the usual 4 inches. Cuts to center of a 20-inch circle.

Carefully check and compare its features and specifications. We feel sure you'll agree it's America's finest 10-inch band saw. (Covered by Design Patent No. 108,245.)

### SPECIFICATIONS

**TABLE:** 10x10-inch, top smoothly ground. Soft metal insert protects blade. Supported on large tongue-type protractor trunnion fitted with graduated scale showing angle of cut up to 45 degrees. Can be fitted with rip fence as shown below. Auxiliary wood table, 5x10 inches.

**BLADE GUIDES:** Each is equipped with self-lubricating bronze guides and ball thrust bearing. One above and one below table. Fully adjustable.

**FRAME:** One-piece casting is ground on joint face. All other holes and surfaces are machined from this face in one operation to insure extreme accuracy. Scientifically ribbed for utmost rigidity.

**DIMENSIONS:** Over-all height, 28 3/4 inches; over-all width, 18 1/2 inches; depth, 10 inches.

#### CRAFTSMAN DeLuxe 10-Inch Band Saw

99 PM 2297—Without motor. Use 1/4-H.P. motor. See Page 43. Shipping weight, 95 pounds. **\$25.90**

#### CRAFTSMAN Standard 10-Inch Band Saw

99 PM 2296—Standard model is exactly the same as the DeLuxe model except in place of ball bearings the wheels are mounted on auto-lubricating bronze bearings, and panels on guard are not aluminum finished like the DeLuxe model. Without motor. Use 1/4-H.P. motor. See Page 43. Shipping weight, 95 pounds. **\$19.95**



### Features of the CRAFTSMAN DeLuxe Model

- Entire mechanism fully enclosed by heavy gray iron frame and front guard that opens like a door.
- Each wheel runs on two SKF ball bearings, sealed and packed with grease for lifetime service.
- Rubber faced 10 1/4-inch wheels.
- Depth of cut, 4 1/4 inches. Cuts to center of 20-inch circle.
- Table tilts to any angle up to 45° on heavy tongue-and-groove trunnions. Angle of cut shown on scale.
- Upper wheel may be raised for adjustment of blade tension, and may be tilted to make blade track correctly.
- Mechanism for adjustment is fully enclosed; adjustments are easily made from outside of machine.

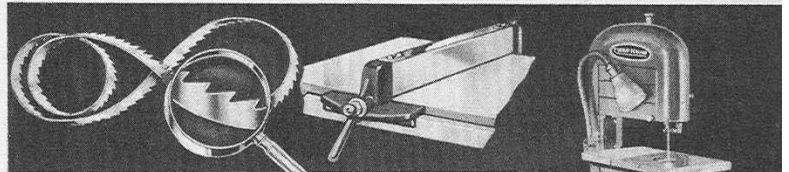

#### Band Saw Blades

For CRAFTSMAN 10-inch band saws. High quality saw steel. Widths, 1/8, 1/4 or 3/8 inch; length, 63 inches. State width. Shpg. wt., 6 oz.

9 P 2665..... **79c**

#### Machine Stand

For your CRAFTSMAN 10-in. band saw. Top, 10x21 in. 29 in. high. Strong and rigid; handy shelf. Shipping weight, 32 pounds

99 P 2743..... **\$4.85**

#### Tool Light

Clamps on band saw. Throws light on your work—keeps it out of eyes. 15-in. flexible neck, reflector, cord and plug. Shpg. wt., 1 lb. 12 oz.

9 P 2264..... **\$1.60**

#### Rip Fence

Specially designed for use with either of the CRAFTSMAN 10-inch band saws described on this page. Front and rear edges of tables are drilled to receive it. A rip fence is very useful in making straight cuts on thin pieces of wood. Use it with blades at least 3/8-inch wide. Shipping weight, 4 pounds.

9 P 2283..... **\$2.25**

Easy Terms! ON ORDERS OF \$20 OR MORE SEE INSIDE FRONT COVER

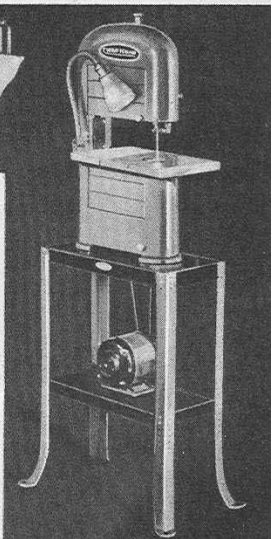

# CRAFTSMAN

REG. U. S. PAT. OFF.

## 12-inch Ball Bearing Band Saw Has Greater Capacity

\$ **29<sup>95</sup>**

Without Motor

- Equipped with precision type SKF ball bearings for long life and smooth, silent operation.
- Handles stock up to 6 inches thick.
- Extra heavy one-piece gray iron frame insures smooth operation and accuracy.
- Oil-impregnated bronze guides increase life of saw blade—prevent hardening.
- Head design maintains constant amount of clearance between wheels and guards.
- Safety type 12-inch rubber-faced wheels, each equipped with two sets finest precision type SKF ball bearings.
- 12½x12-in. well ribbed table—smoothly finished—18x12-in. with wood extension.
- Table tilts up to 45° angle, graduated scale shows exact angle.

### SPECIFICATIONS

**FRAME:** Heavy enough for a saw twice its size! Made in one piece of heavy close-grained gray iron.

**BALL BEARING WHEELS:** Both upper and lower wheel bearings are precision ball bearing type, two sets in each wheel. Practically noiseless. Dynamically balanced wheels of safety design run perfectly.

**BALL BEARING SAW GUIDES:** Another feature found only in higher priced saws. Both upper and lower guides have accurately made ball thrust bearings and are fully adjustable. Properly adjusted, the new type oil retaining bronze guides will keep the saw running true and smooth with minimum frictional loss.

**TABLE:** Ground and polished, of heavy gray iron. Provided with large, rugged cradle upon which table tilts to any desired angle up to 45°. Large easily read scale and pointer tell at a glance the angle to which table is set. Convenient locking handle gives quick control. Table is well ribbed; and two sides are positively lined up by a plate across the slot that is bolted down, eliminating the less efficient retaining screw ordinarily used. Wood extension table at rear increases working surface to 18x12 inches.

**DIMENSIONS:** Height, over all, 33½ inches. Width, over all, 22 inches. Maximum depth, 12 inches.

## Fast Cutting . . . Smooth Running . . . A Big Value!

Here's America's most popular 12-inch band saw—designed for the craftsman who wants a powerful, speedy, smooth-cutting saw at a world-beating price! Cuts through wood up to 6 inches thick with ease and speed. Operates smoothly and silently under the heaviest job. Has that vibrationless perfection that you'll find only in saws of precision manufacture, with high quality ball bearing wheels and an extra heavy frame.

Quieter, more effective guards, mounted so that the upper guard moves up and down with the upper wheel. This keeps proper clearance between the wheel and the guard at all times. Wheels are carefully and individually balanced so as to add to the quiet smoothness with which this saw operates. The upper wheel spindle is carried on a support of new and exclusive design; heavier for greater stability, simpler for easier adjusting to a more positive wheel alignment and blade tension. Oil-impregnated bronze guides lubricate the saw blade in passing, increasing its life and preventing hardening. Feature for feature, price for price, this 12-inch CRAFTSMAN band saw is a real value. Complete with 48-inch belt, ¼-inch wide saw blade, 2½-inch V motor pulley and 72-page book of instructions. Shipping weight, 104 pounds.

99 PM 2304—Without motor . . . . . \$29.95

99 PM 2314—Same as above but with COMPANION 1/3-H.P. ball bearing double shaft motor, 99 P 5607, for 110-120 volt, 60-cycle A.C. See Page 43. Shipping weight, 135 pounds . . . . . \$39.45

249 Terms ON ORDERS OF \$20 OR MORE - SEE INSIDE FRONT COVER



### COMPANION Band Saw Blades

For 99 PM 2304 12-Inch Band Saw. Made of finest quality saw steel, carefully tempered, set and brazed. Tough yet flexible. Built by master saw makers. Shpg. wt., 7 oz.

9 P 2657—Length, 78 inches. Furnished in widths of ¼, 3/16, ¼, 5/16, 3/8 or ½ inch. Specify width wanted . . . . . 89c  
9 P 2658—78-in. Metal Cutting Blade for use on non-ferrous metals such as aluminum, copper, etc. Shpg. wt., 4 oz. . . . . 89c

### Rip Fence

For use on above band saw. Useful in making straight cuts on thin pieces. Use it with blades ½-in. wide.  
9 P 2305—Shipping weight, 6 pounds. . . . . \$2.75

### COMPANION Machine Stand

An all-metal stand for your CRAFTSMAN 12-Inch Band Saw. Top measures 10 in. x 21 in.; height, 29 in. Exceptionally strong and rigid. See Page 40 for detailed description.  
99 P 2743—Shipping weight, 32 pounds. . . . . \$4.85

### COMPANION Tool Light

Clamp it on your band saw. Throws light on your work—extra large reflector keeps light out of your eyes. With 15-in. flexible neck, reflector, switch, cord and plug.  
9 P 2264—Shipping weight, 1 pound 12 ounces. . . . . \$1.60

# CRAFTSMAN

REG. U. S. PAT. OFF.

## 16-inch Ball Bearing Band Saw Built for Heavy Duty Production

- Precision SKF ball bearings in dustproof housings packed with enough lubricant for years of trouble-free service.
- Handles material up to 12 inches in thickness.
- Large 17x18-inch cast iron table has accurately ground surface, correctly ribbed and provided with groove for miter gauge.
- Table mounted on smooth working trunnions; may be tilted 45° to right and 10° to left.
- Self-lubricating bronze guide blocks in saw guides keep blade from hardening. Both right hand guides have micrometer adjustment for more exact work.
- Head design maintains constant clearance between wheel and guard.
- Rubber-faced machined wheels, carefully balanced. Gray iron spoked design.

**\$79<sup>50</sup>**  
Less Motor and Base

\$122.50 Complete

### SPECIFICATIONS

**FRAME:** One piece, extra heavy fine quality gray iron.

**WHEELS:** Highest quality gray iron. Rubber facings on wheels ground after assembly for smooth, vibrationless operation. Lower wheel keyed on tapered shaft, prevents loosening.

**BALL BEARING SAW GUIDES:** Right member of each guide has micrometer adjustment, gives hairline accuracy in cutting. Ball bearing takes the thrust of the saw blade, insuring easy operation and long blade life. Angle of lower right hand guide makes it possible to set guide very close to underside of table.

**TABLE:** 18x17 in. Smooth finish. Heavily reinforced. Easily read scale shows exact degree of tilt—carries stops at 45° and 90°. 2¼-in. aluminum insert protects blade. Equipped with handy rip fence.

**GUARDS:** Saw is almost completely enclosed. Practically unbreakable wheel guards are cast of Zamak. Telescoping arrangement makes it possible to lower the guard down to the work when cutting very thin material or to raise guard to get full clearance when working at 12-inch capacity.

**BEARINGS:** 2 sets dust-sealed SKF ball bearings in each wheel. Packed with lubricant.

**DIMENSIONS:** Height, over all, without base, 50½ in. Width, over all, 30½ in. Maximum depth, 22 in.

## Highest Quality!

Top-notch quality! Built big and husky for professional use—yet it is ideal for the amateur who wants the very best. Cuts with ease through tough wood up to 12 inches thick—so carefully made that it handles small jobs to perfection—has hairline accuracy!

SKF bearings on upper wheel and lower drive shaft give maximum smoothness of operation . . . New type oil-impregnated bronze saw guide blocks protect your blades; make them last longer. A new type mounting for the upper wheel spindle makes possible more perfect alignment. New system of mounting always maintains the same distance between guard and wheel! The wheel and guard are mounted as a unit and move together. The guards are made of Zamak metal and are the last word in safety design. Operates at 600 R.P.M. Complete with 48-in. belt, 2-in. V motor pulley, ¾-in. saw blade, rip fence, and 72-page book of instructions. Shipping weight, 310 pounds.

99 PM 2301—Less base and motor	.....	\$79.50
99 PM 2318—Heavy gray iron base for 99 PM 2301 band saw. Shipping weight, 125 pounds	.....	\$15.75
99 PM 2316—With base and ½-H.P. 1750 R.P.M. 110-volt, 60-cycle A.C. CRAFTSMAN Ball Bearing Motor, 99 PM 5619. See Page 42. Shipping weight, 503 pounds	.....	\$122.50

### COMPANION Band Saw Blades

For 16-inch band saw. Made of very finest quality saw steel, carefully tempered, set, and brazed. We recommend the ¾-inch blade for resawing. Length, 114¾ in. Specify width blade wanted. Shpg. wt., each, 8 oz.

9 P 2659—COMPANION Blade, ½ or ¼ in. wide	.....	\$1.25
9 P 2659—COMPANION Blade, ½ or ¾ in. wide	.....	\$1.35

### Special Length Band Saw Blades

Finest Swedish saw steel. NOT BRAZED. We braze blades for 40¢ each. Shipped from factory at Chicago, Ill. and you pay postage from there. Order from Sears nearest mail order house. State width and length.

Width, in.	¼	¾	½	¾	1	1¼	1½
Shpg. wt., foot	1 oz.	1 oz.	1 oz.	2 oz.	2 oz.	3 oz.	3 oz.
9 P 2669—Per ft.	9c	12c	14c	15c	17c	20c	24c 28c

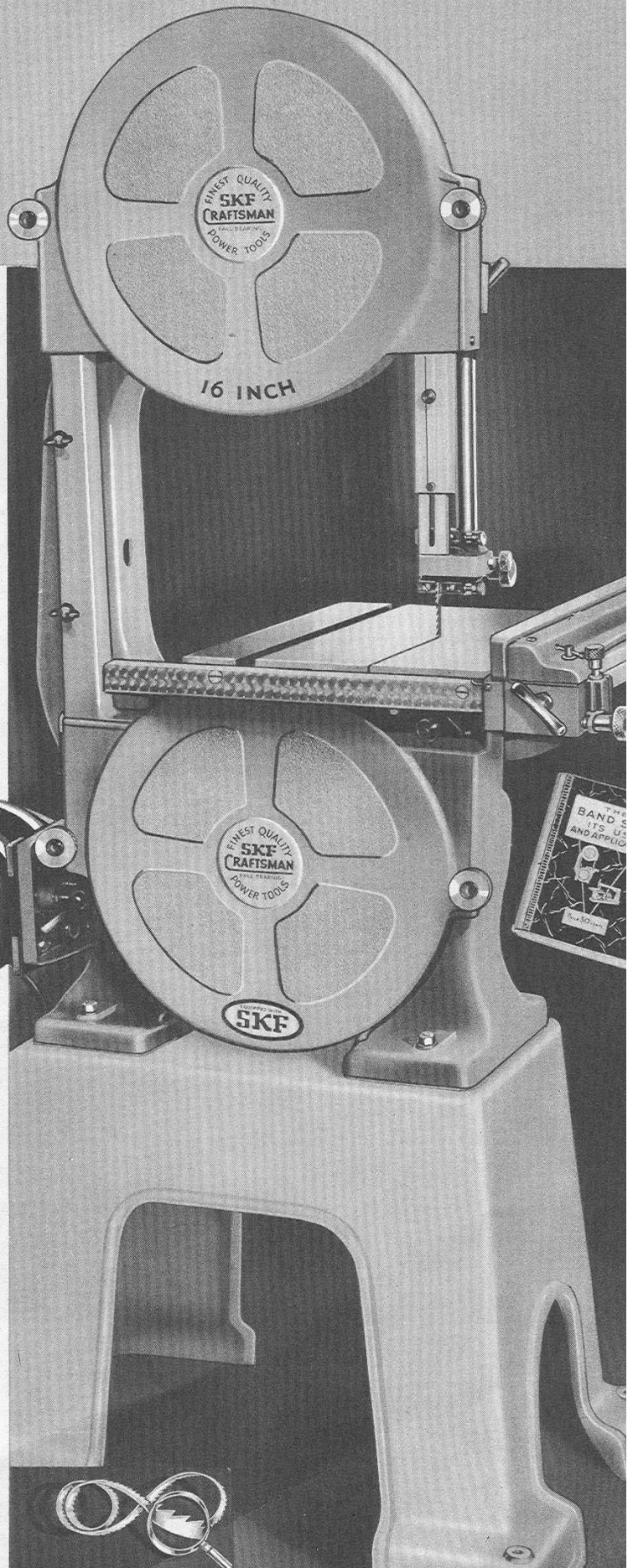

Easy Terms  
ON ORDERS OF  
\$20 OR MORE  
-SEE INSIDE  
FRONT COVER

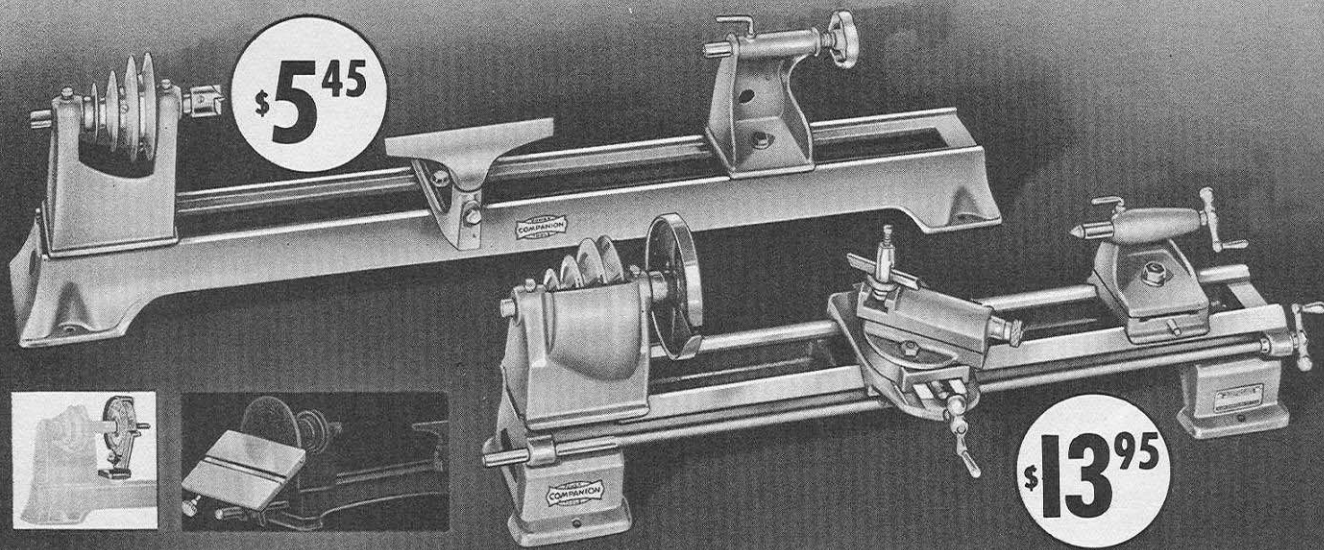

## COMPANION 8x34-INCH WOOD TURNING LATHE

- Double bearing headstock, heavily built.
- Two auto-lubricating bronze bearings for long life.
- Spindle equipped with ball thrust bearing.
- Has three speeds—handles a large variety of work.
- Heavy gray iron bed is accurately machined.
- Sturdy and rigid construction; smooth operation.

You'd never expect so fine a lathe at anywhere near this low price! A good combination of handy size coupled with high quality and advanced performance. We could have built it larger—but we preferred to build it BETTER—with a heavier  $\frac{5}{8}$ -inch finely machined spindle, auto-lubricating bronze bearings, and better cup and spur centers. All parts are carefully fitted to keep the lathe running with smooth efficiency for many years.

This compact lathe will handle work up to 25 inches between centers and up to 8 inches in diameter. The headstock is designed like those on the large factory type production lathes. It's stronger, sturdier, and smoother running. Tailstock is of equally advanced design. Has ball thrust bearing, 6-inch tool rest and all fittings as illustrated. Use  $\frac{1}{4}$  or  $\frac{1}{2}$ -H.P. motor (see Pages 42 and 43). Shipping weight, 22 pounds.



99 P 2013—COMPANION Wood Turning Lathe. \$5.45

### Lathe Grinding Attachment

Shown in left inset above. Fits spindle and bed on 99 P 2013 lathe. Use it for all kinds of grinding work. Includes guard, tool rest, arbor to fit on spindle, 4x $\frac{3}{4}$ -inch grinding wheel, clamps, etc.

9 P 2011—Shpg. wt., 1 lb. 10 oz. \$1.35

### Lathe Sanding Attachment

Shown in right inset above. Do accurate and thorough sanding on your lathe with this handy attachment. Consists of tilting table and clamps for use on lathe above. Use with sanding disc 9 P 2158 below.

9 P 2214—Shpg. wt., 6 lbs. 8 oz. \$2.75

## COMPANION 6x28-INCH METAL TURNING LATHE

- V-way lathe bed . . . 6-inch swing . . . 28-inch bed.
- Double bearing headstock has highest quality bronze bearings. Front bearing fully adjustable.
- Removable No. 0 Morse taper centers in head and tailstock.
- Compound rest fitted with adjustable gibs and lock.
- Full length feed screw insures smooth finish on long pieces.

Has many features of higher priced lathes! A fine tool for the model maker or the man who wants to do light metal work. While not as accurate as the large metal working lathes, its many adjustments make it possible for the operator to secure much more accurate work than has ever been possible with this type of lathe.

Spindle is threaded  $\frac{1}{2}$ x24 threads per inch. Knockout centers in headstock and tailstock. Lead screw provided for longitudinal feed of carriage. Tailstock may be set over for turning tapers. Cross feed and angular feed are gibbed for take up. Use  $\frac{1}{4}$  or  $\frac{1}{2}$ -H.P. motor (see Pages 42-43). Shipping weight, 28 pounds.

99 P 2021—COMPANION Model Makers' Lathe. . . . . \$13.95

### Accessories for Use With the Above Lathe

- 9 P 2788—3-step motor pulley. Specify  $\frac{1}{2}$ -inch bore. Shpg. wt., 1 lb. . . . . 50c
  - 9 P 2137—3-inch 4-jaw independent chuck. Shipping weight, 3 pounds. . . . . \$3.75
  - 9 P 2108—No. 0 Morse taper spur center. Shipping weight, 3 ounces. . . . . 49c
  - 9 P 2109—No. 0 Morse taper cup center. Shipping weight, 3 ounces. . . . . 49c
- For tool bits see 9 P 2205, Page 21; sanding disc, 9 P 2525, on Page 22.

### Jack Shaft for Model Makers' Lathe

Metal turning should be done at much slower speeds than wood turning. Use this handy jack shaft stand to secure proper slow speeds for metal work. Also useful on other tools for changing speeds. Bolt holes are spaced identically with those on motors, permitting it to be used on motor bases of machines, etc. Complete with bronze bushed self-aligning bearings. Shpg. wt., 7 lbs.

9 P 2494—Specify 3-inch 3-step pulley. . . . . \$2.65

## ACCESSORIES FOR WOOD TURNING LATHES

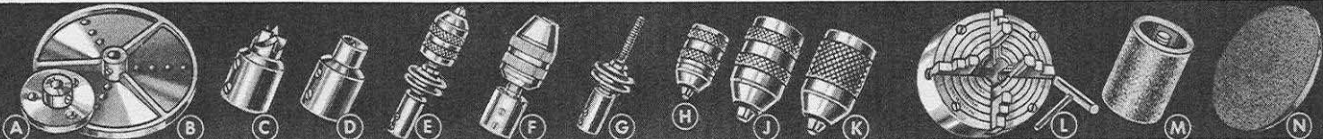

### Face Plates

For number 99 P 2013 or any other lathe with  $\frac{5}{8}$ -in. plain spindles. Carefully machined and balanced.

- A 9 P 2080—3-in. Shipping weight, 7 ounces. . . . . 85c
- B 9 P 2081—6-in. Shipping weight, 14 ounces. . . . . \$1.19

### Spur Center

C For number 99 P 2013 or any other lathe with  $\frac{5}{8}$ -in. spindles. Removable center. Shipping weight, 6 ounces. . . . . 65c

### Cup Center

D Carefully made, hardened steel cup center for tailstock of lathe. Replaceable center pin. Fits any  $\frac{5}{8}$ -in. spindle. Shipping weight, 6 ounces. . . . . 65c

### Work Arbor

E Fits  $\frac{1}{2}$  or  $\frac{3}{8}$ -in. straight spindle. Fastens on  $\frac{1}{2}$ -in. spindle with 2 set screws. Threaded  $\frac{1}{2}$ -inch x 24-thread for 3-jaw  $\frac{1}{2}$ -inch chuck. State  $\frac{1}{2}$  or  $\frac{3}{8}$  in. spindle. Shpg. wt., 1 lb. 10 oz. . . . . 95c

9 P 2118. . . . . 95c

### $\frac{1}{2}$ -in. CRAFTSMAN Drill Chuck and Arbor

F Carefully made 3-jaw steel chuck with adapter, for lathes or motors with  $\frac{1}{2}$ -in. or  $\frac{3}{8}$ -in. straight spindles. Arbor is  $\frac{1}{2}$ -in. x 24-thread. State  $\frac{1}{2}$  or  $\frac{3}{8}$ -in. spindle. Shpg. wt., 1 lb. 6 oz. . . . . 95c

9 P 2140. . . . . 95c

### Work Arbor

G Same as 9 P 2118, above, but without chuck. Has finely faced steel collars to clamp grinding or buffing wheel. State  $\frac{1}{2}$  or  $\frac{3}{8}$ -in. spindle. Shipping weight, 15 ounces. . . . . 45c

9 P 2120. . . . . 45c

### 3-Jaw Chucks

H These 3-jaw chucks are accurately machined to run true. Nicely finished. Superior to ordinary chucks. Fit  $\frac{1}{2}$ -inch 24-thread per inch spindles.

I 9 P 2130— $\frac{1}{4}$ -inch capacity. . . . . 29c

J 9 P 2132— $\frac{1}{2}$ -inch capacity. . . . . 55c

K 9 P 2134— $\frac{1}{2}$ -in. capacity. Ground finish. Shipping weight, 1 pound. . . . . 75c

1 pound. . . . . 75c

### 4-Jaw Independent Chuck

L 4-inch capacity; reversible jaws. Well made, nicely machined. Fits any lathe with  $\frac{1}{2}$ -inch straight spindle. Shipping weight, 3 pounds 12 ounces. . . . . \$4.75

9 P 2136. . . . . \$4.75

### Drum Sander

M Accurately made. Complete with sleeve and adapter. Fits  $\frac{1}{2}$ -in. x 24 threaded shaft. Shipping weight, 12 ounces. . . . . 98c

9 P 2520. . . . . 98c

N 9 P 2522—Sanding sleeve for above drum. Fine, medium or coarse. State grit wanted. Shipping weight, 2 ounces. Each. . . . . 10c

### Sanding Discs

O Carefully machined and balanced aluminum discs fitted with sandpaper. Fit only  $\frac{5}{8}$ -in. straight spindle. . . . . \$1.19

9 P 2158—6-inch. . . . . \$1.19

9 P 2159—8-inch. . . . . 1.65

Shipping wt., 1 lb. . . . . 1.65

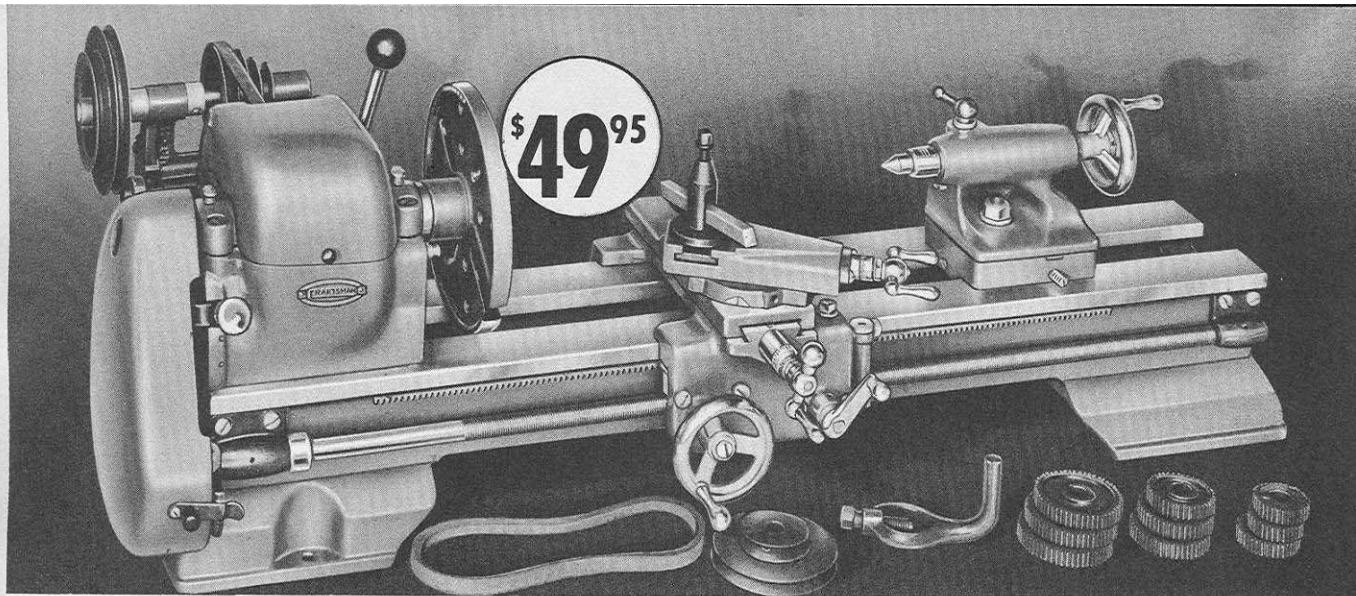

# CRAFTSMAN

REG. U. S. PAT. OFF.

## PRECISION MODEL MAKERS' LATHE BACK GEARED..6-INCH SWING..30-INCH BED

### FEATURES

- New, heavier headstock with larger front bearing.
- Back gears provide much wider speed range—16 speeds: 54 to 3225 R.P.M.
- Threading gears and threading dial included.
- New bench type countershaft with quick belt release lever.
- Ground steel spindle runs in adjustable auto-lubricating bronze bearings. Has 1-in. 8-thread nose.
- Ball thrust bearing takes spindle thrust.
- Hinged countershaft and motor bracket built as part of lathe.
- Lead screw reverse controlled by handy lever at left end of headstock.
- Hinged guards for spindle pulley and feed gears give maximum safety—can be opened quickly.
- Carriage has hand wheel for manual operation and feed lever for automatic feeds.
- Tailstock has set-over for taper turning.

One of the most popular metal lathes we've ever sold! And now this new 1939 model has been greatly improved to make it even a finer tool than ever before. It has a completely new headstock—better, heavier, and with a larger front bearing . . . Back gears are included to provide a much wider speed range . . . New bench-type countershaft has quick belt release lever . . . Threading gears and dial are now included at no extra cost. These are all outstanding improvements certain to make this lathe, even more than ever before, the leader in its price range!

While it is smaller in capacity than our larger CRAFTSMAN Screw Cutting Lathes, it actually matches them in accuracy, precision and performance. *Guaranteed accurate to within one-thousandth of an inch.*

The massive, precision-ground semi-steel bed is rigidly cross braced, and mounted on heavy gray iron legs. The lead screw reverse is mounted on the left end of headstock. Compound rest swivels through 360 degrees and is graduated from 0 to 180 degrees by one-degree divisions. Spindle pulley has 60 indexing holes. Compound rest, carriage, etc. are fully gibbed for take-up. Equipment includes graduated compound rest, tool rest, ring and rocker, 3/8-inch tool bit, bench-type countershaft, motor pulley, belts, face plate, dog, two 60-degree lathe centers, threading dial, change gears to cut 8 to 96 threads, 3 wrenches, and instruction folder. Use 1/2-H.P. motor. See Pages 42 and 43. Shpg. wt., 110 lbs.

**Easy Terms**  
ON ORDERS OF  
70 OR MORE  
SEE INSIDE  
FRONT COVER

99 PM 2048—CRAFTSMAN Model Makers' Lathe . . . \$49.95

### SPECIFICATIONS

Swing over bed: 6 inches.  
Maximum distance between centers: 18 inches.  
Swing over carriage: 4 1/4 inches.  
Length over all: 36 inches.  
Height over all: 11 1/2 inches.  
Depth over all: (including motor): 24 inches.  
Hole through spindle: 1 1/2 inch.  
Spindle nose: 1-inch diameter; 8 threads per inch.  
Taper in headstock: No. 2 Morse.  
Taper in Tailstock: No. 1 Morse.  
16 speeds: 54, 82, 122, 140, 187, 287, 317, 365, 481, 550, 820, 940, 1250, 1950, 2125, 3225.  
Back gear ratio: 6 1/2 to 1 (approx.)  
Lead screw: 1/2-inch; 16 threads.  
Feeds: .0026, .0042, .0052, and .0083 per inch.  
Thread ranges: 8 to 96 threads per inch right or left hand.  
Spindle bearings: Oilless bronze with take-up.  
Countershaft and back gear spindle bearings: Oilless bronze.  
Tailstock ram: Graduated 0 to 1 1/2 inch.  
Cross slide travel: 4 inches.  
Compound rest angular travel: 1 3/4 inches.

## ACCESSORIES FOR MODEL MAKERS' LATHE ABOVE

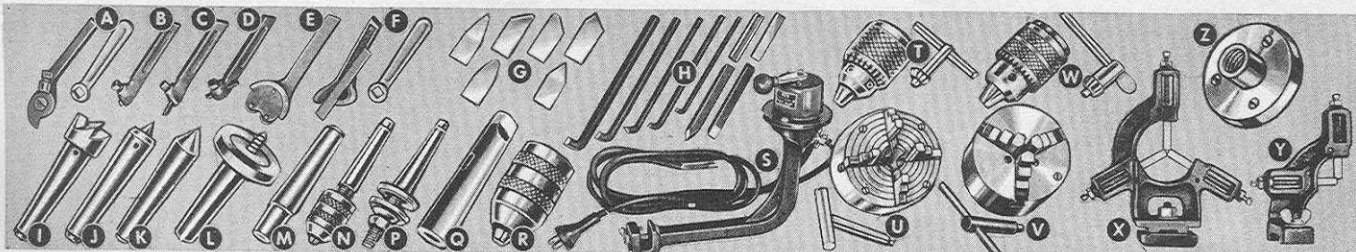

- Tool Holders**  
Fit 99 PM 2048 lathe above. Those holders using tool bits use 3/16-inch bits.
- A 9 P 2031—Threading Tool. Shipping weight, 14 ounces. **\$2.35**
  - B 9 P 2033—Straight Tool Holder. Shipping weight, 12 ounces. **1.00**
  - C 9 P 2034—Right Hand Tool Holder. Shipping weight, 12 oz. **1.00**
  - D 9 P 2035—Left Hand Tool Holder. Shipping weight, 12 oz. **1.00**
  - E 9 P 2036—Knurling Tool. Shipping weight, 14 ounces. **2.85**
  - F 9 P 2037—Cut-off Tool. Shipping weight, 14 ounces. **1.45**
- Formed Tool Bits**  
Set of six 3/16-inch bits to fit above tool holders. Ground to shape. Shipping weight, 5 ounces.  
9 P 2043—Set of 6. **\$1.10**
- Tool Post Set**  
Set includes four boring bars, turning and threading tools, set of spacers. Shipping weight, 14 ounces.  
9 P 2038. **\$4.35**

- Lathe Centers and Arbors**  
No. 2 Morse taper shanks. To fit headstock spindle of 99 PM 2048 above.
- ① 9 P 2107—Spur Center. Shipping weight, 7 ounces. **65c**
  - ② 9 P 2101—Cup Center. Shipping weight, 7 ounces. **65c**
  - ③ 9 P 2111—60 Degree Center. Shipping weight, 7 ounces. **65c**
  - ④ 9 P 2115—Screw Center. Shipping weight, 14 ounces. **95c**
  - ⑤ 9 P 2124—Arbor for Jacobs' Chuck. Shipping weight, 7 ounces. **75c**
  - ⑥ 9 P 2125—Arbor and 1/2-in. Chuck. Shipping weight, 1 lb. 8 oz. **\$1.19**
  - ⑦ 9 P 2163—Arbor for grinding, etc. Shipping weight, 13 ounces. **80c**
  - ⑧ 9 P 2161—Adapter Sleeve to change from No. 2 to No. 1 Morse taper arbor. Shipping weight, 5 ounces. **59c**
- No. 1 Morse taper shanks. (Not illustrated.) To fit tailstock spindle of above lathe. Shipping weight, each, 8 ounces.
- 9 P 2123—Tapered Chuck Arbor. **59c**
  - 9 P 2106—Spur Center. **59c**
  - 9 P 2110—60-Degree Center. **59c**
  - 9 P 2100—Cup Center. **59c**
  - 9 P 2165—Grinding Arbor. **70c**

- 3-Jaw Chuck**  
Superior to ordinary chucks. Fits 1-in. 1/2-inch 24-thread per inch spindles. 1/2-inch capacity. Shipping weight, 12 ounces.  
9 P 2132. **55c**
- Reversing Switch**  
To be used on the above lathe. Shipping weight, 5 lbs.  
9 P 2039. **\$3.95**
- Jacobs' 1/2-Inch Chuck**  
When fitted with arbor 9 P 2123 or 9 P 2124, it may be used either in lathe head or tailstock. Shipping weight, 2 pounds.  
9 P 2142—1/16 to 1/2-inch. **\$5.25**  
9 P 2143—0 to 1/2-inch. **\$6.45**
- Independent Chuck**  
Four reversible jaws move independently. 4 inches in diameter. Fits 1-in. 8-thread spindle on 99PM2048 lathe above. Shipping weight 4 pounds 2 ounces.  
9 P 2138. **\$4.95**

- 4-in. Universal Chuck**  
3-jaw; self centering. Fits 1-in. 8-thread spindle. Shipping weight, 4 pounds 8 ounces.  
9 P 2148. **\$14.75**
- Jacobs' Headstock Chuck**  
Capacity, 0 to 1/2 in. Fits 1-inch 8-thread spindle. Shipping weight, 4 pounds.  
9 P 2044. **\$8.95**
- Steady Rest**  
For accurate work on long pieces. Shpg. wt., 5 lbs. 8 oz.  
9 P 2041. **\$3.50**
- Follower Rest**  
For long slender work. Shipping weight, 3 lbs. 8 oz.  
9 P 2042. **\$2.45**
- Face Plate**  
Fit 1-in. 8-thread spindle as on 99 PM 2048 lathe above. Diameter, 3 1/2 in. Shpg. wt., 2 lbs.  
9 P 2085. **\$1.29**



**CRAFTSMAN**  
REG. U. S. PAT. OFF.

## Convertible Lathe for Wood or Metal Turning . . 9-inch Swing . . 44-inch Bed

- Double bearing headstock (a bearing on each side of the spindle pulley) insures best support for spindle. Permits large diameter work to be turned outboard.
- Special auto-lubricating bronze bearings for long life.
- Headstock ball thrust bearing takes the end thrust that comes on the spindle and insures smooth, easy operation.
- Spindle accurately ground to size for perfect alignment.
- Hollow spindle with 3/8-in. hole is ground to take No. 1 Morse taper centers and arbors. Spindle nose diameter, 3/4 in.; 16-thread.
- Use of No. 1 Morse taper centers in both head and tailstock makes it easy to use work arbors, drill chucks, etc.
- Four speeds ranging from 700 R.P.M. to 4000 R.P.M. — when jack shaft is used, 350 R.P.M. to 8600 R.P.M.
- Can be equipped with compound rest, etc., for metal turning.
- Pulley indexed for dividing, and indexing stop is provided.
- Streamlined tailstock equipped with self-ejecting center with No. 1 Morse taper, ram lock, and set-over for taper turning.
- 44-inch heavy gray iron bed, accurately milled and strongly webbed. 30 inches between centers.
- Rugged headstock guarantees accuracy, rigidity and easy belt shifting for the various speeds required.

You can't match it for quality—features—workmanship—at anywhere near this price! Big enough for 'most any job—and built heavy enough to do metal turning. You can equip it for metal work through the purchase of a few inexpensive attachments! Its swing is large enough so that it is possible to get away from a gap in the bed which would handicap the metal worker in bringing the compound rest up close to the headstock for various other operations.

Bearings are of the auto-lubricating bronze type, surrounded by oil reservoirs, and will give practically limitless service. Specially fitted and installed, they seal the spindle journals from grit and abrasive dust, and insure longer life and greater accuracy. Longitudinal thrust is absorbed by the ball thrust bearing in the headstock. The tailstock may be set over for turning tapers. It is equipped with self-ejecting center and ram lock. Pulley is mounted between headstock bearings so that the spindle is perfectly supported. This makes it possible to turn large diameter work on the outside end of the spindle. When doing such a job on the CRAFTSMAN lathe the work is very close to the outboard bearing and is supported by that bearing. The big, heavy bed is rigid and well braced. It is carefully machined from close grained gray iron.

The headstock is designed to enable the operator to readily shift the belt to the desired step of the headstock pulley for the proper speed. Pulley is accurately indexed so that work may be accurately divided and flutes may be correctly cut into spindles or columns. Headstock spindle has right hand threads inboard and left hand threads outboard, permitting the double threaded face plate 9 P 2090 to be used on either end of the spindle without the necessity of reversing the motor.

Use 1/3-H.P. motor, 1750 R.P.M. shown on Page 43 and 4-inch 4-step motor pulley 9 P 2792 shown on Page 41. Complete with "V" belt, 8-inch tool rest and No. 1 Morse taper spur and cup centers. Shipping weight, 60 pounds.

99 PM 2019.....\$14.50

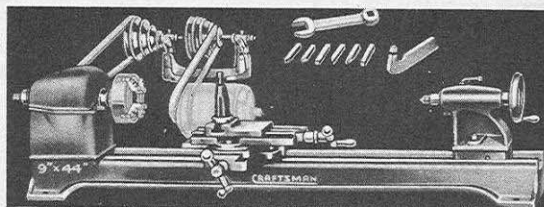

### Complete Metal Working Outfit

This fine metal working outfit incorporates an exceptionally fine quality compound rest graduated to one-thousandth of an inch, angular dial from zero to 180 degrees, longitudinal feed of 6 in. and a transverse feed of 5 3/8 in. The outfit includes our CRAFTSMAN 9-in. lathe, compound rest, production type tool post, tool holder, six tool bits, wrenches, multiple speed jack shaft, 4-in. 4-jaw chuck, belt, pulleys, and 60-degree center. Motor not included.

99 PM 2020—Shipping weight, 93 pounds.....\$37.50

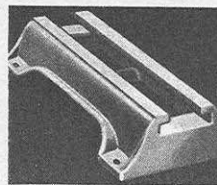

### Lathe Bed Extension

A handy accessory that allows you to turn out work of any desired length on your lathe. 15 inches long. Sturdy—well machined. Made of the same high quality heavy gray iron as bed of 99 PM 2019 lathe. Shipping weight, 11 lbs.

9 P 2017.....\$2.35

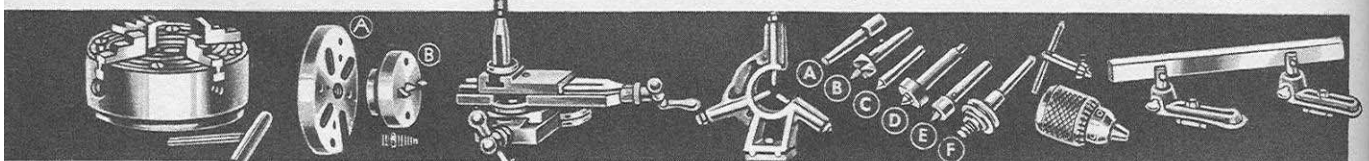

#### 4-Jaw Independent Chuck

4-inch, 4 reversible jaws. Each jaw moves by itself. Key and back plate for 99 PM 2019 Lathe. Shpg. wt. 4 lbs. 4oz. 9 P 2156...\$4.95  
 9 P 2152—3-inch Universal Scroll Chuck. 3 jaws move at once, grip round or hexagonal work. 2 sets of jaws. Back plate fits 99 P.M. 2019 lathe. Shpg. wt., 3 lbs. 8 oz. ....\$12.45

#### High Grade Face Plates

A 9 P 2090 — 5/4-in. wood or metal working face plate, nicely machined and balanced, double threaded for either end of spindle. Shpg. wt., 2 lbs. ....\$1.35  
 B 9 P 2091 — 3-inch face plate with spurs, removable center and screw center. Shpg. wt., 1 lb. 12 oz. ....\$1.10

#### Compound Tool Rest

Precision-built throughout! Feed collars graduated to one thousandth of an inch. Angular dial graduated to 180 degrees. Transverse feed, 5 3/8 inches; angular or longitudinal feed, 6 inches. (For tool bits and holders, see Page 21.) Shipping wt., 17 lbs. 9 P 2168...\$13.90

#### Quality Steady Rest

For supporting extra long work in lathe. Fitted with best quality brass jaws! Very essential when turning long, slender pieces in the lathe. Very well made, sturdy and convenient to use. Shipping weight, 4 pounds. 9 P 2178...\$3.85

#### Lathe Centers and Arbors

No. 1 Morse taper. Accurately ground. Shpg. wt., ea., 8 oz.  
 A 9 P 2123 Tapered chuck arbor...59c  
 B 9 P 2106 Spur center...59c  
 C 9 P 2110 60° grinding arbor...59c  
 D 9 P 2132 1/2-inch chuck for 9 P 2165 grinding arbor...55c  
 E 9 P 2112 60° Ball-bearing center...\$1.95  
 F 9 P 2100 Cup center...59c  
 G 9 P 2165 Grinding arbor...70c  
 H 9 P 2143 Capacity, 9 P 1/2 in. ....\$6.45

#### 1/2-Inch Jacobs' Chuck

Extremely high quality throughout. Cannot be used on threaded spindles. Fits modified No. 2 Morse taper. Use with 9 P 2123 arbor for lathe on this page or 9 P 2124 arbor for lathe on Page 17. Shpg. wt., 2 lbs.  
 9 P 2142—Capacity, 1/4 to 1/2 inch...\$5.25  
 9 P 2143—Capacity, 9 P 1/2 in. ....\$6.45

#### 18-Inch Tool Rest

Well made. Built for long service. Well machined and nicely finished. A great convenience when making long turnings such as table legs or lamp spindles. Readily adjusted for height. Complete with bed brackets. Shpg. wt., 7 lbs. 9 P 2173...\$2.19

Easy Terms  
 ON ORDERS OF  
 \$20 OR MORE  
 -SEE INSIDE  
 FRONT COVER



## CRAFTSMAN Ball Bearing Lathe.. Convertible for Metal Turning.. 10-In. Swing.. 54-In. Bed

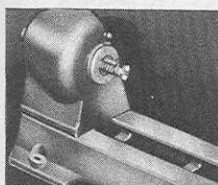

Notice the enclosed design of this heavy headstock.

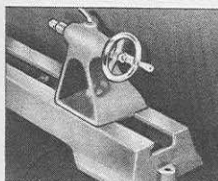

Sturdy tailstock has graduated steel ram.

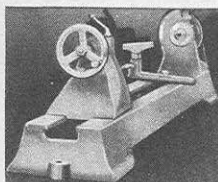

Extra-wide ways and broad, stable construction. Designed for maximum rigidity.

- Extra-heavy, gray iron, flat-way bed with ways 1½ in. wide. Alignment of head and tailstock assured.
- Two heavy duty SKF sealed ball bearings in headstock.
- Accurate. . . . Can be used with metal working attachments.
- Capacity over 36 inches between centers; 10-inch swing.
- Finest quality steel spindle and tailstock ram have No. 2 Morse tapers.
- Headstock pulley and belt covered for added protection.
- Great weight results in smooth, vibrationless operation.

Its great weight, sturdy construction and fine workmanship have already earned an important place for this CRAFTSMAN lathe in professional woodworking and pattern shops all over the country. And now we have added a massive, new, flat-way bed to make it even more outstanding. No other lathe near its price approaches it for value!

Check the features and specifications! See for yourself how far superior this lathe is to any you have ever seen in this price range. It's finer in design, construction and materials . . . larger in capacity . . . and MUCH greater in weight. Full 36 in. between centers. 10-in. swing. This extra weight assures smoother and more accurate operation.

This tool can be converted into a very efficient metal turning lathe with the proper attachments. The headstock spindle rotates on the finest SKF ball bearings for smoothest possible operation and longest life. It has a right hand thread inboard and a left hand thread outboard to allow you to do outboard turning of large pieces without reversing motor or lathe drive. Longitudinal thrust is absorbed by ball thrust bearing. Headstock pulley is indexed so work may be evenly divided or fluted. Complete with 4-step motor pulley, V-belt, cup and spur centers and tool rest.

99 PM 2027—Shipping weight, 115 pounds . . . . . \$26.50

### SPECIFICATIONS

**Bed:** Improved flat-way design produces exceptional sturdiness and rigidity. Extremely heavy ways are fully 1½ inches wide, providing a total bearing surface of 3 inches.

**Headstock:** Covers pulley and belt for safety. Large size and careful design insure easy belt shifting to obtain correct speeds.

**Tailstock:** Fitted with accurately ground steel ram and an automatic knock-out device for removing the No. 2 Morse taper centers and arbors easily and quickly. Ram is graduated in ¼-inch divisions. Tailstock hand wheel is chromium plated.

**Headstock and Tailstock:** Fitted with No. 2 Morse taper sockets for removable centers and arbors.

**Maximum Center to Center Distance:** Over 36 inches.

**Swing:** 10 inches.

**Over-all Length:** 56 inches.

**Spindle:** Outer end is 1 inch in diameter and has 8 left hand threads per inch, eliminating necessity for reversing motor or drive when turning large pieces on the outboard end of spindle.

**Hole Through Headstock Spindle:** ¾ inch.

**Spindle Nose:** 1-in. diameter; 8 threads per inch.

**Spindle Bearings:** Heavy duty SKF, sealed against dust and abrasive materials.

**4 Speeds:** 700, 1300, 2300, 4300 R.P.M.

**Headstock Pulley:** Indexed in 60 divisions.

**Power Recommended:** ¼-H.P. or ½-H.P., 1750 R.P.M. See Page 43 for complete description and prices of motors.

**Equipment:** Four-step ½-inch bore motor pulley, cup and spur centers, tool rest, wrench, and finest quality Vee belt. Metal working attachments available.

Easy Terms  
ON ORDERS OF  
\$20 OR MORE  
- SEE INSIDE  
FRONT COVER



### Independent Chuck

**A** Four reversible jaws move independently. Diam., 4 in. Fits 1-in. 8-thread spindle on 99 PM 2027 lathe. Shpg. wt., 4 lbs. 2 oz. **\$4.95**  
**9 P 2138** . . . . .  
**4-In. Universal Chuck:** 3-jaw, self centering. Fits 1-in. 8-thread spindle. (Not illustrated.)  
**9 P 2148**—Shpg. wt., 4 lbs. 8 oz. \$14.75

### Face Plates

Fit 1-in. 8-thread spindle such as on 99 PM 2027 lathe above.  
**9 P 2085**—Diam., 3½ in. **\$1.29**  
 Shpg. wt., 2 lbs.  
**9 P 2086**—Diam., 9 in. Fits on either end of spindle. **\$2.90**  
 Shpg. wt., 7 lbs.

### Lathe Centers and Arbors

No. 2 Morse taper shanks. Accurately ground for perfect fit. High quality.  
**9 P 2107**—Spur Center. Shipping weight, 7 ounces. **65c**  
**9 P 2101**—Cup Center. Shipping weight, 7 ounces. **65c**  
**9 P 2111**—60-Degree Center. Shipping weight, 7 ounces. **65c**  
**9 P 2113**—Precision Ball Bearing 60-Degree Center. Shipping wt., 8 oz. **\$1.95**  
**9 P 2115**—Screw Center. Shipping weight, 14 ounces. **95c**  
**9 P 2124**—Arbor for Jacob's Chuck. Shipping weight, 7 ounces. **75c**  
**9 P 2125**—Arbor and ½-in. Chuck. Shipping weight, 1 lb. 8 oz. **\$1.19**  
**9 P 2163**—Arbor for grinding, etc. Shipping weight, 13 ounces. **80c**  
**9 P 2161**—Adapter Sleeve to change from No. 2 to No. 1 Morse taper arbor. Shipping weight, 5 ounces. **59c**

### Sanding Drum and Sleeves

**N** By using this drum on your lathe you can do sanding in a jiffy. Handy for sanding around curves. Has rubber backing. Fits grinding arbor 9 P 2165 or 9 P 2163. Diam., 2½ in.; 3 in. long. With adapter and one sleeve. Shpg. wt., 12 oz. **98c**  
**9 P 2520**—Sanding Drum. Shipping weight, 2 ounces. Each. **10c**  
**9 P 2522**—Sanding Sleeve. Coarse, medium or fine. State grade. Shipping weight, 2 ounces. Each. **10c**

### Steady Rest

**9** Ideal for supporting extra long work in lathe. Handy when turning long slender pieces. Best quality brass jaws. Shipping weight, 3 pounds 10 ounces. **\$4.65**  
**9 P 2023** . . . . .

### Compound Tool Rest

**5** Precision built! New heavy design. Fits 99 PM 2027 or old model 99 PM 2022 with round bed. Angular dial graduated to 180 degrees; swivels through 360 degrees. Transverse feed, 6½ in.; longitudinal feed, 7½ in. Tool holder not included. Use tool holders on Page 21. Shpg. wt., 29 lbs. **\$15.65**  
**9 P 2094** . . . . .

### 24-Inch Tool Rest

**7** With adapter for flat or round bed lathe like 99 PM 2027. With bed brackets. Shpg. wt., 10 lbs. **\$3.19**  
**9 P 2095** . . . . .



# CRAFTSMAN UNIVERSAL HEAVY DUTY LATHE

## Built to Handle Big Jobs . . . Wood or Metal

### FEATURES

- Convertible for metal turning, screw cutting, milling, grinding, etc.
- Heavy, rugged, semi-steel bed; ways accurately ground and finely finished.
- Massive heavy duty headstock equipped with highest quality Timken dustproof precision type roller bearings.
- Hollow spindle, 1½-inch diameter, accurately machined for No. 3 Morse tapers. Has sleeve to take No. 2 Morse taper centers and arbors.
- 4-speed pulley with 60-hole spindle indexing mechanism for dividing.
- Accurate spindle thrust adjustment.
- Heavy duty tailstock has exceptionally broad base. May be set over for turning tapers, has accurate witness mark, fitted with automatic center ejector and coordinate lock. Quill machined and ground for No. 2 Morse taper centers. Graduated along top.
- Wide speed range—575 to 2875 R.P.M. Countershaft and back gears give 16 speeds from 32 R.P.M. to 2100 R.P.M.

Thousands of professional craftsmen, schools, pattern shops and woodworking establishments have long wanted an extra-fine wood turning lathe like this CRAFTSMAN Universal Heavy Duty Lathe. As a wood lathe it's an outstanding engineering development! Even more—you can convert this lathe into a precision-type metal turning and screw-cutting lathe simply by adding the necessary parts and accessories. You can get the same metal cutting accuracy and durability in our Universal Lathe fitted with the units listed at the bottom of this and the opposite page, as in the best screw-cutting lathe offered by any manufacturer near \$100! Every job that can be handled on a wood turning lathe or on a metal working, screw-cutting lathe can be done on the CRAFTSMAN Universal Heavy Duty Lathe and its attachments.

The heavy semi-steel bed with its broad, accurately machined ways, is heavy enough to resist all torsional stresses. The headstock is fitted with high quality selected Timken tapered roller bearings. These fine bearings are used in machine tools of the utmost accuracy, tools that sell for thousands of dollars. They are the finest heavy duty bearings made—typical of the quality, workmanship and material going into this fine tool. The spindle is 1½ inches in diameter and will pass a ¼-in. rod. The head-stock pulley is accurately indexed. The tailstock, a heavy duty type, may be set over for tapers, and is fitted with self-ejecting No. 2 Morse taper cup center and coordinate ram lock.

The fact that this lathe was designed for conversion into a precision metal lathe means much to the woodworker. To meet the requirements for metal working a lathe must have such rigidity, such accuracy, such bearings that it is ideal for production wood working.

The CRAFTSMAN Universal Heavy Duty Lathe opens up new fields! It gives you two lathes in one—because you can easily and economically add the necessary parts to convert it into a genuine precision-type metal working and screw-cutting lathe. All necessary holes for attaching these added parts are already drilled and tapped.

The sturdier construction and exceptionally fine heavy duty Timken bearings enable this lathe to handle metal spinning operations with great ease.

99 P 2025—CRAFTSMAN Universal Timken Bearing Heavy Duty Lathe complete with centers, belt, rest, wrench and motor pulley. Shipping weight, 165 pounds . . . . . \$45.00

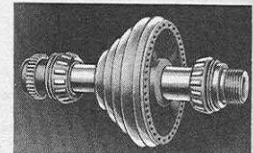

Massive, specially designed headstock spindle fitted with heavy duty Timken precision roller bearings. This accurately made spindle accommodates No. 3 Morse tapers and has sleeve to No. 2. The nose has an accurately cut thread. The well balanced 4-speed pulley has 60 accurately spaced holes for indexing, dividing, etc. Large spring loaded indexing lock.

### SPECIFICATIONS

Swing over bed: 12¼ inches.  
 Length, over-all: 54 inches.  
 Height, over-all: 16 inches.  
 Depth, over-all: 7 inches.  
 Maximum distance between centers: 36 inches.  
 Number of speeds: 4.  
 Speeds: 575, 1035, 1725, 2875.  
 Tailstock set over: ¾ inch.  
 Indexed headstock pulley: 60 positions.  
 Hole through spindle: 2½ in.  
 Spindle nose: 1½ in., 8-thread.  
 Headstock spindle: has No. 3 Morse taper (with sleeve to No. 2).  
 Tailstock: has No. 2 Morse taper in ram.  
 Tailstock ram travel: 2¾ inches.  
 Tee rest length: 12 inches.

Easy Terms ON ORDERS OF \$20 OR MORE - SEE INSIDE FRONT COVER

## These Units Will Convert Your Universal Lathe Into

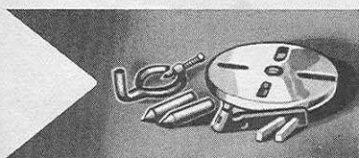

**Metal Turning Outfit.** This is an outfit that is essential for use in metal turning and we recommend that you include it in your order when buying parts necessary to convert your universal lathe to a metal turning screw cutting job. You'll find it worthwhile. Fine quality accessories at a money saving price. Consists of two No. 2 Morse taper 60-degree centers, tool holder, 2 tool bits, 1-inch dog and 6-inch face plate machined to fit 99 P 2025 CRAFTSMAN Universal Heavy Duty Lathe. Shipping weight, 5 pounds.  
 9 P 2068 . . . . . \$5.95

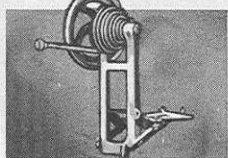

**Countershaft Assembly.** A valuable addition to your lathe for metal working. Selection of 8 speeds: 170, 270, 430, 504, 680, 832, 1298 and 2100 R.P.M. Low speeds are entirely practical for 2-inch cold rolled steel, 2½-inch cast iron or a 5-inch armature when used with the proper feed. For still lower speeds use back gears 9 P 2058, on opposite page. Complete with fittings, ready to attach. Shipping weight, 22 pounds.  
 9 P 2072 . . . . . \$13.90

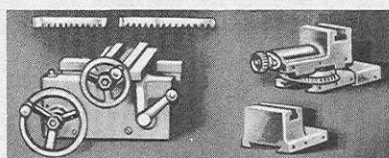

9 P 2074—Carriage and Rack Assembly. Carriage fitted with half nuts for later addition of lead screw. Has adjusting gib and locking gib. Shipping weight, 21 pounds. . . . . \$14.65

9 P 2070—Carriage Compound Rest. Fitted with adjusting gib, accurately calibrated 180-degree protractor, feed screw collar calibrated for .001-in. feed. Shipping weight, 10 lbs. . . . . \$10.60

9 P 2066—Carriage Plain Rest. An economical unit for jobs not requiring swivel feature. Shipping weight, 5 pounds. . . . . \$4.95

9 P 2064—Tool Post complete, for use with plain or compound rests. Shipping weight, 1 pound . . . . . \$1.95

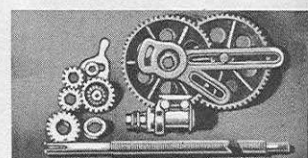

**Lead Screw and Feed Gears.** Used with 9 P 2074 carriage and rack assembly (and 9 P 2066 carriage plain rest or 9 P 2070 carriage compound rest) produces longitudinal power feed to carriage of .0087 or .0043 in. per revolution of spindle. Power feed produces much smoother cuts because the carriage advances a regular amount for each revolution of the spindle. Reverse feed mechanism included. Easy to attach. Does not include threading gears. Complete with necessary fittings for attaching to your CRAFTSMAN Universal Lathe. Shipping weight, 10 pounds 7 ounces.  
 9 P 2060 . . . . . \$13.95

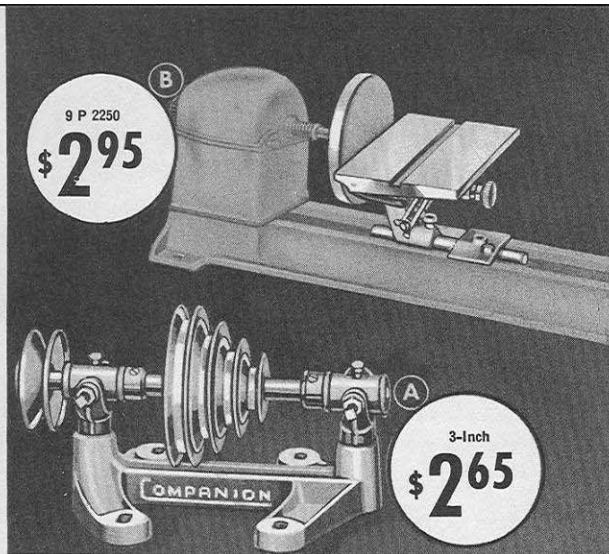

### Jack Shaft Stand

Ⓐ Use this handy accessory to get proper lathe speeds and extra cutting power for metal working. Also used for speed variation on other machines. You must have the proper speed to get the best results from your tools. Bolt holes are placed the same as those on motors, permitting use on motor bases of machines, etc. Complete with bronze bushed self-aligning bearings. Shpg. wt., each, 7 lbs. 8 oz.

9 P 2494—State size.  
With 3-inch 3-step pulley..... \$2.65  
With 4-inch 4-step pulley..... 2.75  
With 5-inch 4-step pulley..... 2.85

### Sanding Attachment

Ⓑ For perfect sanding jobs. Rugged table is firmly mounted on lathe bed. May easily be tilted to any angle. Sanding disc not included (see below). Shipping weight, 9 pounds.

Cat. No.	For Lathe	Price
9 P 2250	99 PM 2019 on P. 16	\$2.95
9 P 2096	99 PM 2027 on P. 17	2.95
9 P 2251	99 PM 2025 on P. 18	2.95

8-Inch Sanding Discs. Threaded to fit lathe spindles. Shpg. wt., 2 lbs.

Cat. No.	For Lathe	Price
9 P 2160	99 PM 2019 on P. 16	\$2.19
9 P 2162	99 PM 2027 on P. 17	2.19
9 P 2164	99 PM 2025 on P. 18	2.35

## CRAFTSMAN Turning Chisels

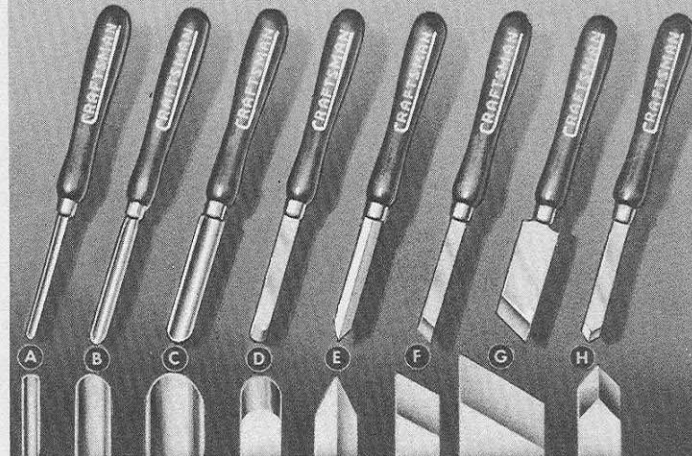

### 59¢ CRAFTSMAN Wood Turning Chisels and Gouges

Exceptionally high quality 4-inch blades of carefully tempered, brightly polished tool steel. Expertly ground. Keep a bitingly keen edge. Can't be beat for fast, easy, clean cutting. 8-inch handles, beautifully finished and given a special polishing which won't dull with wear. Shaped and balanced for easy handling. Heavy ferrule. You'll like the feel of these tools and get plenty of useful service from them. Shipping weight, each, 13 ounces.

Gouges		Round Nose		Skew Chisel	
Ⓐ 9 P 2850	¼-inch wide..... 59¢	Ⓓ 9 P 2856	½-inch wide..... 59¢	Ⓕ 9 P 2862	½-inch wide..... 59¢
Ⓑ 9 P 2851	½-inch wide..... 69¢			Ⓖ 9 P 2863	1-inch wide..... 85¢
Ⓒ 9 P 2852	¾-inch wide..... 89¢	Parting Tool		Spear Point	
		Ⓔ 9 P 2858	½-inch wide..... 59¢	Ⓗ 9 P 2854	½-inch wide..... 59¢

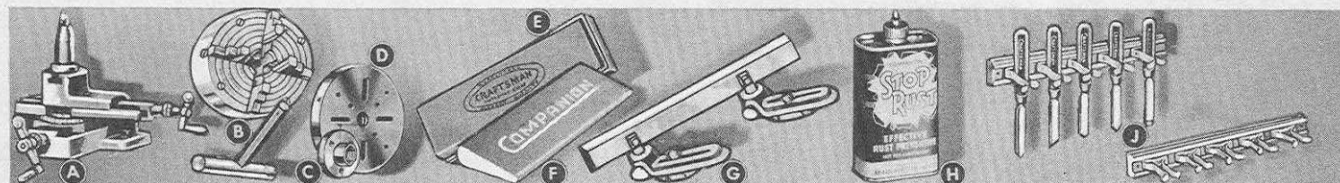

### Compound Rest

Ⓐ Precision built. Direct bed-attached. Feeds are calibrated to .001-inch. Swivel to 180 degrees. Two anchor studs. Production tool post.  
9 P 2076—Shipping weight, 21 pounds. \$14.65

### Independent Chuck

Ⓑ 6-inch chuck. Has 4 reversible jaws. Fits the Universal Heavy Duty Lathe. Jaws are hardened and tempered. Perfectly fitted.  
9 P 2139—Shpg. wt., 8 lbs. 12 oz..... \$9.25

### Face Plates

For woodworking. For 99 PM 2025 lathe or any lathe with 1½-inch, 8-thread spindle. Well balanced and machined.

Ⓒ 9 P 2097—¾-inch size. Shipping weight, 2 pounds..... \$1.25  
Ⓓ 9 P 2098—6-inch size. Shipping weight, 3 pounds..... \$1.65

### CRAFTSMAN Sharpening Stone

Ⓔ Vitrified silicon carbide. One side medium for fast cutting; other side fine for smooth edge. Size, 7x2x1 inches. Shipping weight, 1 pound 8 ounces.

9 P 6440..... \$1.25

### COMPANION Slip Stone

Ⓕ Gives extra keen edge to gouges and other round shaped tools. Medium-fine.  
9 P 6454—Shpg. wt., 12 oz..... 45¢

### Tool Rest

Ⓖ 24-inch rest. A great convenience when doing long turnings. Built for long service. Readily adjustable for height. Well machined and nicely finished. Complete with bed brackets. Shpg. wt., 12 lbs.

9 P 2063..... \$2.95

### Stop Rust

Ⓗ This rust-preventive has been laboratory tested and is used by our own power tool manufacturers. Spread on the surface of any metal it forms a smooth film which will protect your most valuable machinery and tools. Not intended for use as a lubricant. The finely polished and ground surfaces of your power tools are machined to very accurate limits. They deserve the protection of COMPANION Stop Rust. This is especially true in basement shops or in shops where the humidity is exceptionally high. ½-pint can. Shpg. wt., 8 oz.

9 P 2927..... 29¢

### Handy Tool Clips

Ⓙ Your tools will remain bright and sharp, when they're safely in place on these handy tool clips. They'll be handier, too—right at your finger's tips when you want them, not on the floor or lost underneath a table or cabinet.

The clips are made from the finest spring steel. And they're adjustable in grip tension to accommodate any type of tool you may have—from the smallest to the largest. Clips are mounted in groups of five on a nicely finished wood strip. Get several—have a place for every tool—save your time and tools. Shpg. wt., 10 oz.

9 P 2865—5 mounted tool clips without chisels..... 25¢

## A Precision Metal-Working, Screw-Cutting Lathe!

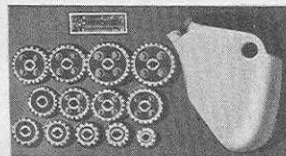

**Thread Gears and Chart.** With power feed assembly, opens up whole new field of thread cutting possibilities. For cutting all standard threads 4 to 80 threads per inch, (left or right) including pipe threads. Shipping weight, 5 pounds.  
9 P 2056..... \$6.35

**Gear Guard Assembly.** Offers maximum convenience and safety to operator. Complete with all fastenings and ready to attach. Shipping weight, 16 pounds.  
9 P 2054..... \$4.95



**Thread Dial.** Simplifies thread cutting by indicating when to engage carriage; prevents spoilage. Shipping weight, 8 ounces.  
9 P 2052..... \$1.60

**Steady Rest.** Brass jaws. Required for long turnings; assists in maintaining accuracy. Shipping weight, 7 lbs.  
9 P 2050..... \$4.60

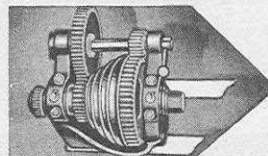

**Back Gears.** For attachment to special Timken bearing headstock lathe No. 99 PM 2025. With countershaft attachment, provides 16 speeds. Lowest speed, 32 R.P.M. Makes possible the greatest range and capacity of work for metal working lathe. Low speeds are essential for large work and heavy cuts.  
All necessary parts and fittings are supplied to fit the drilled and tapped holes of 99 PM 2025 lathe. Instructions furnished. Shipping weight, 14 pounds.  
9 P 2058..... \$11.95

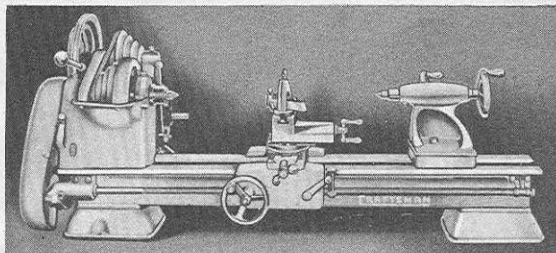

We believe the CRAFTSMAN Universal Heavy Duty lathe and its accessories to be the most flexible group of lathe equipment ever offered. This lathe is the finest bench type wood working lathe we have ever seen! Fitted with compound rest, centers, etc., it is an excellent armature lathe, or by the addition of other equipment it can be built into a most accurate screw cutting metal working lathe.

# MASTER CRAFTSMAN

REG. U. S. PAT. OFF.

99 PM 2028  
\$77<sup>50</sup>



## 12-INCH SCREW CUTTING LATHES

- Guaranteed accurate to .001 inch.
- Heavily reinforced semi-steel bed with precision-ground ways.
- Mogul type semi-steel headstock with high speed line reamed babbit bearings. Heavy duty ball thrust bearing.
- Countershaft is integral part of the lathe, a complete self-contained unit including motor mounting.
- Back gears are 12-pitch 7/8-inch face special type giving plenty of power.
- Threading gears cut all standard right and left hand threads from 4 to 80 per inch, including Vee pipe thread.

- Semi-steel tailstock has set-over for taper turning. Fitted with center ejector and coordinating ram lock. Ram graduated in 16ths of an inch.
- Non-slip V-belt drive with adjustable belt tension and release lever.
- Heavy semi-steel carriage has adjustable gibs for take-up. Positive lock on quill; threading dial, etc.
- Compound rest swivels and locks at any angle and is graduated in one degree divisions from 0° to 180°.
- Reverse gear controlled by convenient lever at left of headstock for quickly reversing lead screw.

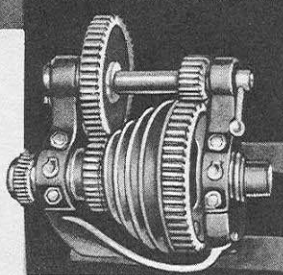

View of headstock showing large line reamed high speed babbit bearings. Finest quality ball thrust bearing and husky back gears.

### SPECIFICATIONS

**Swing over bed:** 12 1/4 in.  
**Swing over carriage:** 8 1/2 in.  
**Maximum distance between centers:** See table of bed lengths.  
**Length over all:** 45 in. (42-inch bed).  
**Height over all:** 19 in.  
**Depth over all:** 25 1/2 in.  
**Hole in spindle:** 2 1/2 in.  
**Spindle nose:** 1 1/2 in. diameter. 8 threads.  
**Taper in headstock spindle:** No. 3 Morse, sleeve to No. 2 Morse.  
**Taper in tailstock spindle:** No. 2 Morse.  
**Number of speeds:** 8 or 16 as specified at right.  
**Speed range:** 8-speed lathe; 170, 270, 430, 504, 680, 832, 1298 and 2100. 16-speed lathe; 32, 50, 74, 88, 120, 142, 170, 210, 270, 350, 430, 504, 680, 832, 1298 and 2100.  
**Lead Screw:** 8 Acme threads per inch.  
**Cross slide travel:** 6 1/2 in.  
**Compound rest angular travel:** 2 3/4 in.  
**Tailstock set over:** 3/4 in.  
**Has witness mark and graduated ram.**

The finest workmanship—design—materials—and features are combined in this lathe to make it far superior to anything in its field. Compare it—feature for feature, specification for specification—with any other lathe on the market! See for yourself why thousands are in daily use in factories, garages and homes—wherever a truly fine lathe is desired! We have used materials and machining methods which are the best available. Each step in the manufacturing process is rigidly inspected. Each individual finished lathe, before it is shipped, must undergo a series of tests to insure utmost accuracy and satisfaction. **Guaranteed accurate to .001 inch.**

**HEADSTOCK:** Semi-steel, precision milled and machined. Bearings filled with special high speed babbit. Bearings are bored and line reamed in a massive precision fixture after headstock is mounted on bed. This method of machining insures accurate alignment with bed. Be sure the lathe you buy has such fine babbit filled bearings with double screw caps such as are used on the world's finest tools.

**BED:** The heavy bed is given a rough milling cut, seasoned thoroughly, milled and ground to a fine accurate surface, checked for accuracy, finish ground and finally rechecked with Brown and Sharpe master surface plate.

**SPINDLE:** Special alloy steel. Fitted with ball thrust bearing. Special machining guarantees accurate threading and concentricity of bore.

**TAILSTOCK:** Semi-steel, accurately aligned with headstock by special arbor. Actual test cuts on lathe must show less than .001 inch error.

99 PM 2028—CRAFTSMAN 8-speed, 12-inch screw cutting lathe. 36-inch bed, 18 inches between centers with unit countershaft and line reamed babbit headstock bearings, compound rest, thread cutting gears and reversible feed, wrenches, belts, etc. Less motor and back gears. Shpg. wt., 218 lbs. . . . \$77.50  
 CRAFTSMAN 16-speed, 12-inch screw cutting lathes. As above but also equipped with back gears.

Easy Terms  
ON ORDERS OF \$20 OR MORE - SEE INSIDE FRONT COVER

Catalog No.	Bed Length	Cap. Between Centers	Shpg. Wt.	Less Motor
99 PM 2065	36 in.	18 inches	230 lbs.	\$89.50
	STANDARD			
99 PM 2067	42 in.	24 inches	238 lbs.	\$95.00
99 PM 2069	48 in.	30 inches	248 lbs.	\$102.50
99 PM 2071	54 in.	36 inches	256 lbs.	110.00

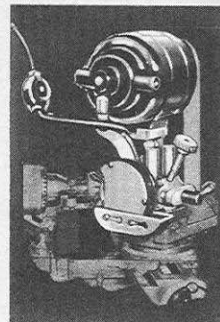

### Universal Tool Post Grinder

Grinds valves and cutters at any angle. Also pistons, bushings, reamers, valve stem bushings, valve stems, lathe centers. Undercuts mica. Complete with motor, external and internal grinding wheels, quill for internal grinding, 5 mica undercutting saws and diamond wheel dresser. Shipping weight, 23 pounds. 9 P 2998. . . . \$45.00



### Tool Light

(A) Throws the light exactly where you want it. Keeps it out of your eyes. Has flexible neck and extra large reflector. Complete with cord and plug. See Page 24 for detailed description. Shpg. wt., 1 lb., 12 oz. 9 P 2264. . . . \$1.60

### Center Gauge

(B) For checking lathe centers and setting threading tool. Tempered steel. Shpg. wt., 1 oz. 9 P 4064. . . . 40c

### Center Drill

(C) With countersink. High grade steel. 3/32 or 1/8-inch diameter. State size. 9 P 2061—Shpg. wt., 1 oz. 25c

### Follower Rest

(D) For jobs requiring a long cut on small diameters. Fastens to back of carriage—follows cutting tool. Shpg. wt., 4 lbs. 9 P 2988. . . . \$2.75

### Face Plate

(E) 8 1/2 inches in diameter. Shipping weight, 6 pounds. 9 P 2087. . . . \$3.50

### Crotch Center

(F) For centering round work, for tailstock drilling. Shpg. wt., 1 lb. 9 P 2114. . . . 95c

### Micrometer Carriage Stop

(G) Insures accurate facing and turning. 9 P 2185—Shpg. wt., 1 lb. . . . \$3.25

### Drill Pad

(H) 9 P 2187—Shpg. wt., 1 lb., 2 oz. . . . 95c

### Tool Post Tool Set

(J) High speed tool steel. Includes set of tool post spacers; 4 boring tools; 3/16, 1/4, 3/8 and 1/2-inch; one 1/4-inch inside threading tool; one 1/2-inch turning tool and one 3/4-inch threading tool. Shipping wt., 2 lbs. 9 P 2189. . . . \$4.35



36-Inch  
\$112<sup>00</sup>

# MASTER CRAFTSMAN DE LUXE

## SMOOTH, EVEN POWER—ACCURACY GUARANTEED

Sears finest! Outstanding in every way; workmanship—materials—accuracy—versatility—VALUE! Ideal for home, school, or professional shop—for any craftsman who wants the very best lathe his money can buy! Has ALL the features that make our 16-speed lathes on opposite page leaders in their field PLUS, ideas never before offered at this price. DeLux fittings throughout. Equipped with finest Timken tapered roller bearings for the greatest accuracy and longest life. These bearings are not just standard Timken bearings. We spend plenty of money to have these bearings specially selected to maintain the alignment of the main spindle to very close limits. They will carry very heavy loads at slow speeds and yet operate perfectly at high speeds. They are the finest bearings we could secure—the type used in large machine tools selling for thousands of dollars. Belt guards completely cover the headstock—assuring maximum safety for the operator. Guards are hinged and may be easily opened to change speeds. It's the finest lathe you can buy at anywhere near this price. All we ask is that you see it and compare it before you purchase ANY lathe!

The enviable reputation that CRAFTSMAN metal lathes have earned is based on sound design, the best of materials and a final inspection of each individual lathe. A rigorous series of tests prove positively that the lathe is built accurate to .001 of an inch as we guarantee it. Complete with specially selected Timken tapered roller bearings, guards and countershaft drive.

Catalog No.	Bed Length	Cap. Between Centers	Shpg. Wt.	Less Motor
99 PM 2073	36 in.	18 inches	250 lbs.	\$112.00
	<b>STANDARD</b>			
99 PM 2075	42 in.	24 inches	260 lbs.	\$119.00
99 PM 2077	48 in.	30 inches	270 lbs.	\$129.00
99 PM 2079	54 in.	36 inches	280 lbs.	\$139.00

**Easy Terms!**  
ON ORDERS OF \$20 OR MORE - SEE INSIDE FRONT COVER

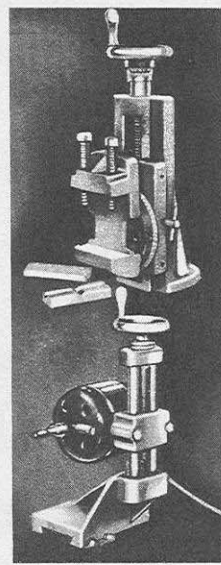

**Milling Attachment**  
Has graduated swivel vise, V-block for holding cylindrical objects. Vise capacity, 2 3/4 in. Vertical feed, 2 3/4 in. Micrometer graduated feed screw. Cross feed, 5 in. Angular swivel accurately graduated in degrees. Shipping weight, each, 16 lbs.  
9 P 2987—New type; fits lathes above and on opposite page. Fastens to carriage by 2 heavy set screws. \$14.45  
9 P 2993—Fits old model CRAFTSMAN lathes; fastened to carriage by two bolts from below. \$14.45

**Mica Undercutting Attachment**  
Fastens to back of carriage; goes into action in a jiffy. Not necessary to remove cutting tool. Universal motor for 110-120-volt D.C. or A.C. 25-60 cycles, switch, cord, set of 5 undercutting saws. Shipping weight, 10 pounds.  
9 P 2989...\$19.95

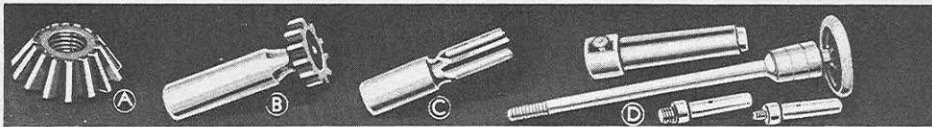

**High Speed Steel Milling Cutters**  
**(A) Angular Type.** Carefully ground and well made. For use with threaded adapters supplied with holding collet No. 9 P 2994 listed at right. For face milling or dovetailing. Shipping weight, each, 3 oz.  
9 P 2995—State size.

Diam.	Thick	Hole	Price
1 1/4 in.	7/16 in.	3/8 in.	\$3.35
1 1/2 in.	3/8 in.	1/2 in.	3.75

**(B) Wood-ruff Keyway Cutters.** 1/2-in. shank. Well made and carefully ground. Shipping weight each, 4 ounces. State size.

Diam.	Thick	9 P 2996
1/2 in.	1/8 in.	\$1.85
3/4 in.	3/16 in.	2.10
1 in.	1/4 in.	2.45
1 1/4 in.	3/8 in.	2.85
1 1/2 in.	1/2 in.	3.25

**(C) R. H. Cut, R. H. Spiral End Mills.** Used with 9P2994 and 9P2985 at right. Shipping wt., each, 3 oz. State size.

Diam.	Flute	9 P 2997
1/4 in.	3/16 in.	\$1.20
3/16 in.	1/16 in.	1.25
3/8 in.	3/8 in.	1.40
1/2 in.	1/2 in.	1.65
3/4 in.	1 1/16 in.	1.75

**(D) Holding Collet**  
For milling cutters. Furnished with 3 arbors, to take threaded hole angular cutters, keyway cutters and 1/2-inch end mill. Holds milling cutters firmly. Shipping wt., 3 lbs.  
9 P 2994...\$5.25  
9 P 2985—Set of 4 Collet bushings for use with 1/4, 3/16, 3/8, and 1/2 in. end mills. Shipping wt., 4 oz. \$5.85



**Tool Holders**  
Steel forgings, carefully finished. For 1/4-in. tool bits. Shipping weight, each, 2 pounds.  
(A) 9 P 2198—Threading...\$2.60  
(B) 9 P 2202—Knurling Tool...\$3.20  
(C) 9 P 2192—Offset, Right... 1.10  
(D) 9 P 2196—Straight... 1.10  
(E) 9 P 2194—Offset, Left... 1.10  
(F) 9 P 2200—Cut-Off... 1.60

**6 Formed Tool Bits**  
High speed steel, 3/4 in. Shpg. wt., 8 oz. Set consists of:  
(G) Threading Bit.  
(H) L. H. Facing Bit.  
(J) R. H. Turning Bit.  
(K) Round Nose Turning Bit.  
(L) R. H. Facing Bit.  
(M) L. H. Turning Bit.  
9 P 2205—Set of 6...\$1.10

**(N) 5-in. 3-Jaw Universal Scroll Chuck**  
Self centering. With 2 sets of jaws. 9 P 2150—Shpg. wt., 6 lbs. 11 oz...\$17.95  
**(O) 6-in. 4-Jaw Independent Chuck**  
9 P 2139—Shpg. wt., 8 lbs. 12 oz...\$9.25  
**Heavy Duty 8-in. 4 jaw Independent Chuck**  
9 P 2141—Shpg. wt., 22 lbs...\$13.95  
All above chucks have back plate to fit spindle nose on above lathes—1 1/2 in. by 8-thread.

**Steady Rest**  
(R) For long, slender work. Brass jaws. Capacity, up to 2 7/8-in. Shpg. wt., 7 lbs.  
9 P 2050...\$4.60  
**(S) Spindle Nose Chuck**  
Hollow; takes 1/4 to 3/8 in. Also may be used on tailstock with adapter. Shpg. wt., 4 lbs.  
9 P 2144...\$9.95

**Lathe Dogs**  
(T) 9 P 2183—Drop forged. Be sure to state size.

Size	Shpg. Wt.	Price
1/2 in.	1 lb.	50c
3/4 in.	1 lb.	55c
1 in.	1 lb.	60c
1 1/2 in.	1 lb.	70c

# THE TOOL OF A THOUSAND USES



## COMPANION FLEXIBLE SHAFT EQUIPMENT

- Soft steel grease-tight casing with solid brass ferrule at each end. Over-all length, 43 inches. Designed for flexibility and long life.
- Select high tensile steel wire core, wound in alternate layers to form strong, compact, yet flexible drive of many layers. Over-all length, 43 inches.

- Steel ends of core carefully machined and securely swaged on.
- Wide variety of accessories available for all kinds of work.
- Adapter provided to accommodate accessories having ½-inch 24-thread hole.
- Wide range of speeds for all kinds of work.

- Handpiece spindle runs on two sets of ball bearings for longest life.
- Every outfit rigidly inspected at the factory before shipment to insure perfect running of every moving part.
- Mounted on ball bearing caster base to provide utmost portability.

The finest flexible shaft outfits ever built for anywhere near these low prices! You'll be amazed at the quality of workmanship and materials used in every detail of their construction. Thousands of these outfits are in daily use for grinding, polishing, buffing, sanding, refinishing, paint removal, etc. Because of their great portability you can take them right to the job. They roll easily on the ball bearing caster base. For use in the shop, the garage, the home, they have no equal. With these outfits you can perform a large number of diversified operations with ease and facility. Once you own one you will wonder how you were able to get along without it!

Every part of this outfit is built for service. No detail is skimmed... no corners are cut... the quality is kept at Sears high standard even in

the smallest part or accessory. The reason you can buy a Flexible Shaft Outfit from Sears for about HALF what others ask for similar quality is that we sell more outfits than any other distributor in the country. Our huge volume enables us to cut buying, shipping and handling costs. As a result you are sure of BIGGEST SAVINGS plus the HIGHEST QUALITY when you buy your outfit from Sears.

**99 P 2475**—Flexible Shaft Outfit shown above, with 7½-ft. flexible shaft and accessories shown above, but without motor. Shipping weight, 40 pounds. . . . . \$19.95

**99 PM 2476**—Flexible Shaft Outfit as above, complete with COMPANION ⅓-H.P. ball bearing motor for 110-120 volt, 60-cycle A.C. 1750 R.P.M. Shipping weight, 66 pounds. . . . . \$29.45

### EXTRA ATTACHMENTS MAY BE PURCHASED SEPARATELY

	Shpg. Wt.	Price
9 P 2489—Base with Casters	4 lbs. 8 oz.	\$1.39
9 P 2491—Table for Portable Outfit	5 lbs. 14 oz.	1.10
9 P 2495—Support for Jack Shaft	4 lbs. 8 oz.	1.00
9 P 2497—Jack Shaft	1 lb. 7 oz.	1.35
9 P 2500—Ball Bearing Handpiece	1 lb. 8 oz.	1.19
9 P 2505—Casing, 43-inch	2 lbs. 12 oz.	1.19
9 P 2510—Core, 43-inch	1 lb.	1.19
9 P 2515—Grip for Shaft	1 lb. 10 oz.	.30
9 P 2510—Grinding Wheel Guard	1 lb. 6 oz.	.65
9 P 2130—Drill Chuck, ¼-inch	5 oz.	.29
9 P 6484—Carbon Removing Brush	4 oz.	.49

	Shpg. Wt.	Price
9 P 2520—Sanding Drum with Belt and Adapter	12 oz.	98c
9 P 2522—Sanding Belts for Drum. Fine, medium or coarse. State choice.	2 oz.	10c
9 P 2526—6-in. Sanding Disc	1 lb.	65c
9 P 2529—6-in. Rubber Pad	4 oz.	35c
9 P 2239—6-in. Disc with Rubber Pad	1 lb. 4 oz.	89c
9 P 2526—6 Sanding Discs, 6-inch	1 lb. 5 oz.	25c
9 P 2535—½-Pt. Can Cement	1 lb. 2 oz.	39c
9 P 2792—4-inch Four-Step V Pulley	1 lb. 10 oz.	55c
9 P 2751—Endless V Belt, 24-inch	3 oz.	27c

	Shpg. Wt.	Price
9 P 2531—Sheepskin Polishing Pad	4 oz.	79c
9 P 6490—6-inch Cloth Buffer	3 oz.	15c
9 P 2537—Lubricant, per tube	7 oz.	19c
9 P 6402—4x½-inch Grinding Wheel	1 lb. 2 oz.	35c
9 P 6480—4-inch Coarse Wire Wheel	5 oz.	35c
9 P 6482—4-inch Fine Wire Wheel	5 oz.	45c
9 P 6487—Floor Waxing Brush, 6-in.	11 oz.	49c
9 P 2543—Drill Chuck Adapter	6 oz.	30c
9 P 2533—Sheepskin Polishing Drum	3 oz.	49c
9 P 6485—2¾-inch Wire Cup Brush	4 oz.	49c
9 P 6486—6-inch Tampico Brush	8 oz.	49c

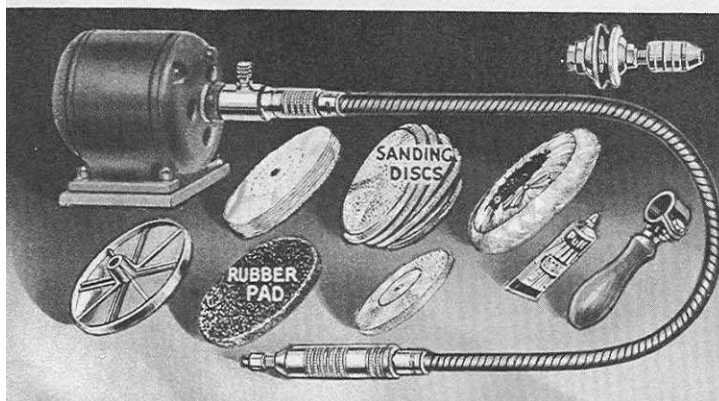

### COMPANION DIRECT DRIVE FLEXIBLE SHAFT

**9 P 2630**  
**\$7.45**  
**The Handiest Motor Attachment of All**  
 Here's an inexpensive flexible shaft for the craftsman who has his own motor with a ½-inch drive shaft. Motor coupling fits directly on motor shaft. Motor coupling is fitted with ball bearings. Included are ½-inch three-jaw chuck, chuck adapter and motor coupling, sanding disc wheel, package of assorted sanding discs, graphite lubricant, sheepskin polishing pad, 6-inch cloth buffer, 4x½-in. grinding wheel, flexible shaft casing and core, hand grip, ball bearing handpiece, and rubber pad. Length, over all, 50 in. To double the length an extra core No. 9 P 2510 and casing No. 9 P 2505 may be added. This handy outfit will more than pay for itself in the work it saves you. Outfit does not include motor. Shipping weight, 8 pounds 12 ounces.

- 9 P 2630—Complete Outfit as illustrated. . . . . \$7.45
- 9 P 2629—Outfit except accessories shown inside shaft. Shipping weight, 4 pounds 12 ounces. . . . . \$5.45
- 9 P 2546—Ball Bearing Motor Coupling used in above outfit. For ½-inch motor shaft only. Shipping weight, 11 ounces. . . . . \$1.29

Additional Accessories Listed in Tables Above

Easy /  
 Tools  
 ON ORDERS OF  
 250 OR MORE  
 -SEE INSIDE  
 FRONT COVER

# CRAFTSMAN HEAVY DUTY INDUSTRIAL FLEXIBLE SHAFT



**WHAT YOU GET IN THE COMPLETE OUTFIT**  
Individual Items May Be Ordered Separately

9 P 2480—Industrial Flexible Shaft, Casing, Core and Hand Piece. (No motor coupling.) Shpg. wt., 12 lbs.	\$38.50
9 P 2489—Base with Casters. Shpg. wt., 4 lbs. 8 oz.	1.39
9 P 2491—Table for motor. Shpg. wt., 5 lbs. 14 oz.	1.10
9 P 2495—Jack Shaft Support. Shpg. wt., 4 lbs. 8 oz.	1.00
9 P 2482—Ball Bearing Jack Shaft for use with 9 P 2480 above. Shpg. wt., 3 lbs. 4 oz.	16.95
99 P 5608—1/2-H.P. Motor. 3450 R.P.M. Ball Bearing Repulsion-Induction. (See Page 43). Shpg. wt., 33 lbs.	19.95
9 P 2751—V-Belt. 3/8x24 inches. Shpg. wt., 3 oz.	27c
9 P 2792—Cone Pulley. 4-inch; 4-step. Shipping weight, each, 1 lb. 10 oz. (2 supplied). Each.	55c
<b>99 PM 2492—COMPLETE OUTFIT (Including all of above items) Shpg. wt., 60 lbs.</b>	<b>\$78.50</b>

**CRAFTSMAN Heavy Duty Industrial Shaft Outfit.** By far the finest Sears has ever sold! Much bigger... Much heavier... Much stronger. Built for service on tough production jobs. We sincerely believe it's far superior to ANY outfit selling for half again as much!

The handpiece is much larger and heavier in construction. Special alloy steel throughout—all parts carefully ground and fitted. Scientifically designed to prevent entrance of grit or foreign matter to the bearings. Equipped with precision SKF ball bearings. The jack-shaft is built of special alloy steel and equipped with SKF precision ball bearings. The 6-ft. casing is built of an inner layer of tempered steel wire, overlaid with a layer of dead soft wire; this is covered with a braided bronze jacket which prevents stretching; then finally covered with a heavy layer of rubber which prevents any possible leakage of oil or grease. Core is 3/16-inch in diameter and 6 ft. long. Built of transversely wound layers of high carbon steel wire. Fittings are made of chrome nickel steel. Speed range, 1000 to 6000 R.P.M. Equipped with 1/2-H.P., 110-120 volt A.C., 3450 R.P.M. ball bearing, repulsion-induction motor.

99 PM 2492—Complete with all items listed above. Shpg. wt., 60 lbs. \$78.50  
 99 PM 2488—Complete as above, but less motor. Shpg. wt., 28 lbs. 59.50  
 9 P 2481—Industrial Flexible Shaft Core only. Shpg. wt., 4 lbs. 4 oz. 9.25  
 9 P 2487—Special Bargain Outfit. Industrial flexible shaft, casing, core, handpiece and direct motor coupling (9 P 2486 described below). Supplied to fit 1/2-inch motor shaft. Shipping weight, 14 lbs. 8 oz. \$39.50

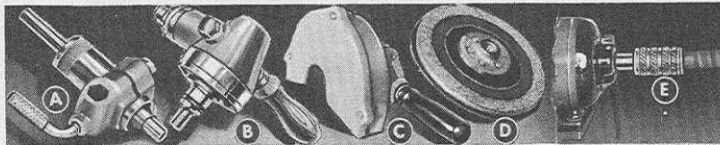

### Accessories for Heavy Duty Industrial Flexible Shaft

- (A) Ball Bearings Jack Shaft.** Heat treated. Fits directly on jack shaft support 9 P 2495. Finest construction. SKF ball bearings. Shipping wt., 3 lbs. 4 oz. 9P2482 \$16.95
- (B) Angle Head.** Heat treated, spirally cut steel gears run in grease-tight housing. SKF precision ball bearings. Shipping wt., 3 lbs. 8 oz. 9P2483 \$16.95
- (C) Grinding Wheel Guard.** Fits on hand piece. An absolute necessity when doing grinding or wire wheel work with your flexible shaft. Shipping weight, 2 lbs. 8 oz. 9P2484... \$4.75
- (D) Sanding and Grinding Disc.** Flexible rubber disc. Ideal for fenders, etc. Shpg. wt., 2 lbs. 4 oz. 9P2485... \$6.50  
 9P2490—Six replacement sanding discs. Shpg. wt., 6 oz. \$1.45
- (E) Direct Motor Coupling.** Precision SKF ball bearings. Regularly supplied for 1/2-inch shaft. Also available for 3/8 or 3/4-inch bore from factory in New Jersey. Shpg. wt., 1 lb. 10 oz. 9P2486... \$6.25

## FLOOR TYPE HEAVY DUTY Industrial Flexible Shaft

All the features—all the fine quality—all the oversize rugged construction of the Heavy Duty Industrial Flexible Shaft described at left, but in a floor type model. Built to stand up under the toughest production jobs in large industrial shops.

This splendid outfit is ideal where there are frequent changes in the location of the job and where there is a wide range in the types of work to be done. The heavy cast-iron base is mounted on easy-rolling ball bearing casters. The tool tray is amply spaced for grinder and polishing wheels, etc.

Motor and jack-shaft are supported by husky steel yoke which swivels and locks in any desired position instantly. Height is adjustable to suit work. Stand is made of telescoping steel tubes, making it possible to further extend the height of the shaft in such operations as polishing automobile tops, etc. Speed range, 1000 to 6000 R.P.M. Equipped with 3450 R.P.M., 1/2-H.P. 99 P 5608 ball bearing motor. (See Page 43.)

99 PM 2479—Complete with motor. Shpg. wt., 172 lbs. \$97.50  
 99 PM 2478—Without motor. Shpg. wt., 137 lbs. \$78.50



## HIGH SPEED SHAFT OUTFITS AND ACCESSORIES

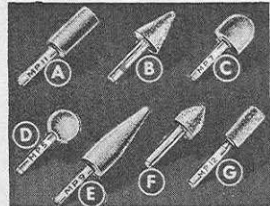

### Grind Stones

For high speed grinding, including finish grinding, die work, etc. May be used with the high speed flexible shaft outfit shown at right. Equipped with 3/16-inch shanks. Shipping weight, each, 3 oz.

- (A) 9 P 6462—MP11... 48c
- (B) 9 P 6457—MP3... 48c
- (C) 9 P 6459—MP7... 48c
- (D) 9 P 6459—MP5... 48c
- (E) 9 P 6461—MP9... 59c
- (F) 9 P 6458—MP4... 48c
- (G) 9 P 6463—MP12... 48c

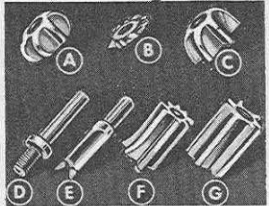

### Carving Cutters

High speed cutters, accurately made of finest quality tool steel. For use with the high speed flexible shaft at right for high speed routing. Shipping weight, each, 2 ounces.

- 9 P 2644—Specify item wanted.
- (A) Round Nose... \$1.59
- (B) Pointed Liner... 1.59
- (C) Half Round... 1.59
- (D) 3/16-inch Cutter Shank... 45c
- (E) Button Drill... 1.59
- (F) Hook Tool... 1.59
- (G) Straight Face... 1.59

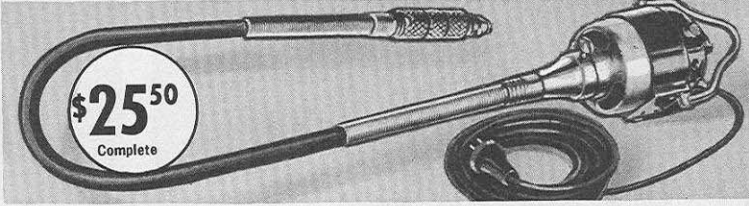

### Highest Quality High Speed Shaft Outfits

Handpiece fitted with two sets SKF ball bearings. Takes standard accessories. Powerful, 17,000 R.P.M., 110-volt Universal type A.C. or D.C. motor. 50-inch shaft fitted with steel supports at ends. For high speed carving, grinding, etc.

- 99 P 2635—Complete High Speed Shaft: core, casing, motor coupling, ball bearing handpiece and motor. Shpg. wt., 12 lbs. \$25.50
- 9 P 2634—High Speed Flexible Shaft Outfit as above but less motor. Shpg. wt., 3 lbs. \$11.50
- 99 P 2642—High Speed Motor only. Use with router or flexible shaft. Shpg. wt., 10 lbs. \$14.40
- 9 P 2643—High Speed Motor Coupling only. For flexible shaft. Shpg. wt., 1 lb. 8 oz. \$1.65
- 9 P 2638—Extra High Speed Casing. Shipping weight, 1 pound 4 ounces. \$4.25
- 9 P 2639—Extra High Speed Core. Shipping weight, 1 pound. \$1.95
- 9 P 2640—High Speed Collet Chuck. Choice of three sizes to fit 1/8, 1/4, or 3/16-inch tool shanks. Specify size. Shpg. wt., 6 oz. \$8c
- 9 P 2645—SKF Ball Bearing Headstock. For standard or high speed shafts. Shipping weight, 2 pounds 12 ounces. \$5.75
- 9 P 2637—SKF Bearing Handpiece. Like 9 P 2500 but better quality. For standard or high speed shafts. Shpg. wt., 1 lb. 8 oz. \$3.65

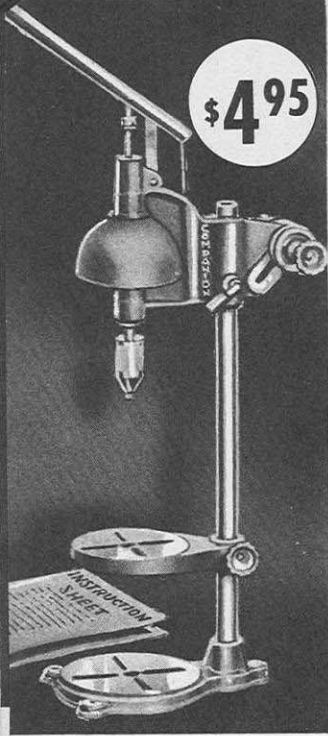

**\$4.95**

## COMPANION

### 3/8-INCH UTILITY DRILL PRESS

- For wood or metal drilling.
- High grade bronze bearings.
- Ball thrust bearing in head.
- Fine quality 3/8-inch drill chuck. 1 5/8-inch spindle travel.
- 3/4-inch spindle reduced to 1/2-inch at chuck.
- Height, over all, 31 1/4 inches.

A small drill press built right—large enough to handle most all your drilling. It is built with the same column construction as the larger drills. The over-size bearings are bronze with large ball thrust bearing mounted in head. Adjustable drill head and table. 5-inch diameter table. Base is 6-inch diameter with extension at rear. Base is 9 inches deep over all. Column is ground steel, 3/8 inch in diameter. Drills to center of an 8-inch circle. Distance from column to chuck, 4 inches. 3-step 3-inch cone drive pulley on spindle is covered by guard. Equipped with adjustable idler drive and spring loaded feed lever. Shipping weight, 18 pounds.

99 P 2374.....\$4.95

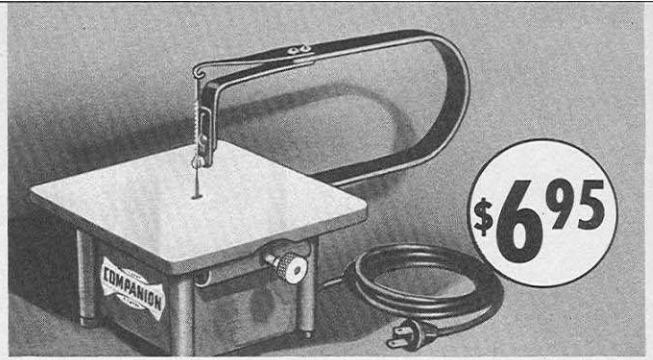

**\$6.95**

## COMPANION Magnetic JIG SAW

*Ideal for Fast Fine Work*

- Speed! 7200 strokes per minute. Length of stroke easily adjusted.
- Complete—no motor to buy. No rotating motor parts to get out of order.
- Plugs into any 110-volt, 60-cycle household A. C. socket.
- Very smooth cut—no sanding necessary. Safer than regular jig saws.

Exactly what you need for those intricate sawing jobs—jobs in thin wood that must be done accurately. The COMPANION Magnetic Jig Saw handles up to 3/4-inch stock, but is particularly recommended for light work. Within its field, you can't beat it. It cuts a perfect right angle or a circle as small as 1/4-inch in diameter (as large as desired) . . . leaving absolutely smooth edges that need no sanding. It does the job by using high speed—7200 strokes per minute, and a stroke of 3/4 to 1/2-inch. The stroke length can be regulated simply by turning the adjustment knobs.

The COMPANION Magnetic Jig Saw is complete in itself. No need to buy a motor. Just plug it in—that's all.

The high speed—short stroke, vibrating action of this COMPANION Jig Saw coupled with its freedom from belts makes this tool unusually safe, even for the younger craftsmen. The low price makes it a great power tool value!

9 P 2299—Shpg. wt., 17 lbs. . . . \$6.95  
 9 P 2690—Package of 6 special blades for COMPANION Magnetic Jig Saw. Shipping weight, 1 ounce. . . . .15c

# START A WORKSHOP! SAVE AT SEARS LOW PRICES

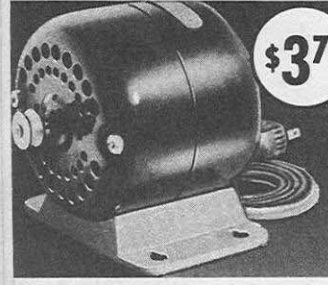

**\$3.75**

### "JUNIOR" Electric Motor

A smooth-running motor for the "Junior" tools above. 110-volt, 60-cycle A.C. Turns 3400 R.P.M.—has plenty of power to keep your "Junior" tools humming with activity. Has brass pulley for use with the rubber drive belt 9 P 2727 shown below (9 P 2727 must be used with this motor). With cord and plug. Shpg. wt., 7 lbs. 6 oz.

9 P 2725.....\$3.75

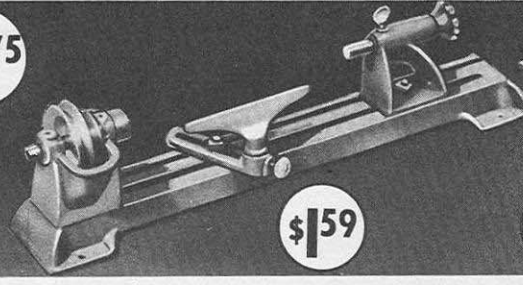

**\$1.59**

### "JUNIOR" Lathe

Here's your chance to get a real wood-working lathe at a great saving. Lathe has a two-speed pulley, 5-inch swing, regular spur and cup center, and a 5-inch adjustable tool rest. Capacity, 12 inches between centers. A sturdy, rigidly constructed lathe with a machined bed. Shipping weight, 8 pounds.

9 P 2728.....\$1.59



**\$2.19**

### "JUNIOR" Bench Saw

Good craftsmanship needs good sawing . . . and that's exactly what you get with this top-notch "Junior" Bench Saw. It does a good job, quickly and easily. It's a great help in turning out good work rapidly and easily. Includes a 5 1/2 x 8 1/2-inch table, adjustable in height . . . a rip fence and miter gauge . . . a shaft extension with collars and nuts for accessories . . . and a 4-inch blade that cuts fast, smooth and clean. Shipping weight, 8 pounds.

9 P 2729.....\$2.19



**\$1.69**

### "JUNIOR" Jig Saw

No workshop is complete without a jig saw. It's indispensable for pattern cutting—for intricate sawing of light wood stocks—for work that must be done carefully and with particular neatness. The "Junior" Jig Saw has a 10-inch throat . . . 8-inch diameter table . . . enclosed spring head . . . and a rigid cast iron frame. It will cut out some mighty difficult circular and angular patterns—quickly and with remarkable smoothness. Worth much more than we ask. Shipping weight, 9 pounds.

9 P 2730.....\$1.69

### Rubber Drive Belt for "JUNIOR" Tools

For use with "Junior" motor 9 P 2725 above. Rubber clings to the drive pulley and makes sure all the power is used.

9 P 2727—Shipping weight, 2 ounces.....10c



### Cast Iron Glue Pot

With aluminum cup. Built like a double boiler. Outer cup of heat-retaining cast iron for water. Inner glue cup of non-corroding aluminum. Capacity of glue cup, 1/2 pint. Has convenient handle. Shipping weight, 4 pounds 8 ounces.

9 P 2887.....\$1.10



### Electric Glue Pot

The convenient way to heat your glue. Thermostat automatically controls heat. Element is completely embedded in asbestos. Polished aluminum with gray iron frame. One-pint cup with cord and plug. Listed by Underwriters. Stir wire included. For 60-cycle 110-120 volt A.C. only. Shpg. wt., 6 lbs. 8 oz.

9 P 2892.....\$3.75

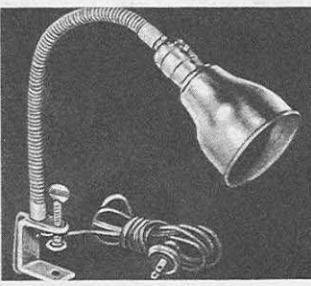

### COMPANION Tool Light

The 15-inch flexible neck lets you bring the light down to your work just where you want it. New type adjustable clamp. An extra large reflector keeps the light out of your eyes—a real safety feature. Over-all length, 23 inches. Complete with push switch in socket, clamp, cord and plug. Bulb not included. Shpg. wt., 1 lb. 12 oz.

9 P 2264.....\$1.60



### CRAFTSMAN Apron

Made from excellent quality heavy white canvas with high front to protect the shirt. Extra long, full 42 in., so as to come well below knees. Large, handy, strongly sewed pocket.

9 P 2950—Shipping weight, 9 ounces.....39c



### Wood Dowel Rod Assortment

Fourteen assorted sizes ranging from 1/4 to 3/4-inch in diameter. Length, 16 in. Very handy for model building and mending furniture. Exceptionally clean grain hard wood. Value, 40c.

9 P 2909—Shipping weight, 14 ounces.....17c

# COMPANION DRILL PRESS

... Built for Substantial Service ... Low in Cost!

- 1/2 inch capacity 3-jaw chuck.
- New design table with diagonal slots.
- Drills to center of 12-inch circle.
- Ball thrust-bearing absorbs spindle thrust.
- Auto-lubricating bronze spindle bearings.
- Quill is graduated full 3 inches in 1/16-inch divisions.
- Quill uses standard mortising attachments.
- Spindle provided with stop collar.
- "Feather-touch" clamp locks head to column.
- Extra sturdy base serves as auxiliary table.

Fine design! Quality! Construction! Smooth operation! An outstanding drill press in every way—and a super-value! Fully capable of handling mortising, shaping, carving, and routing as well as drilling. Wide range of 7 speeds allows efficient work to be done on either metal or wood. Precision-ground steel spindle is cushioned against thrust by high-grade-ball thrust bearing. Extra large auto-lubricating bronze bearings increase smoothness and long life. Quill of high quality steel, finely machined. Accurately cut teeth mesh with wide faced steel feed pinion. Spindle unit balanced for ultra-sensitive feeding. Table is slotted and accurately ground. Can be had with idler assembly for lineshaft drive (see small illustration at right) at \$2.50 extra on original order only. If ordered later, see 9 P 2371 listed below.

**99 PM 2378**—COMPANION Drill Press, complete with "V" belt, 4-step motor pulley, and 1/2-in. 3-jaw chuck, less motor. Equipped with motor bracket. For idler drive add \$2.50 to selling price and specify "Idler Drive." Shipping weight, 60 pounds.....\$14.50

**99 PM 2373**—Same as above but with COMPANION 1/2-H.P. 110-volt 60-cycle ball bearing motor. Shipping weight 102 pounds.....\$24.00

**99 PM 2369**—Same as 99 PM 2378 above but fitted with 1/8 to 1/2-in. capacity Jacobs' chuck. Without motor. Shipping weight, 60 pounds.....\$18.95

**9 P 2371**—Belt and idler assembly only for lineshaft drive. (No credit for return of old motor bracket.) See 99 PM 2378 above for cost as original equipment. Shipping weight, 7 pounds.....\$3.60

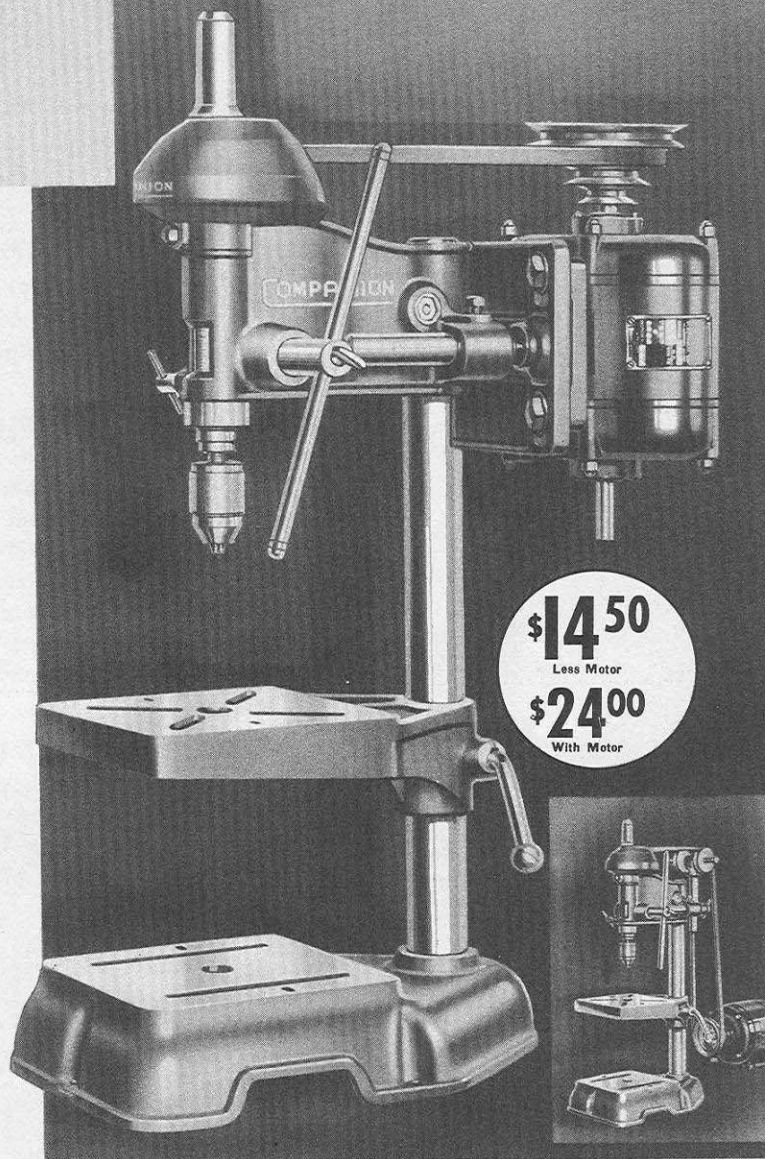

**\$14.50**  
Less Motor  
**\$24.00**  
With Motor

## SPECIFICATIONS

Height, over all: 31 in.  
Width, over all: 9 1/4 in.  
Depth with motor: 24 in.  
Table to chuck jaws: 7 3/4 in.  
Base to chuck jaws: 10 3/4 in.  
Spindle travel: 3 in.  
Column diameter: 1 1/2 in.  
Chuck capacity: 1/2 in.  
Table travel: 7 3/4 in.  
7 speeds: 700, 1075, 1300, 1725, 2300, 2760, 4000.  
Table size: 7 1/2 x 7 1/2 in.  
Drills to center of 12-in. circle.

Easy Terms ON ORDERS OF \$20 OR MORE SEE INSIDE FRONT COVER

## Hollow Chisel Mortising

Cut mortises quickly with perfectly square ends or drill square holes by using this equipment. Shipping weight, 3 pounds.

**9 P 2461**—Mortising Chisel Housing.....\$1.50

**9 P 2451**—Collet Chuck for use with mortising bits. Shipping weight, 3 ounces.....69c

Hollow chisels and bits for use with 9 P 2461 mortising attachment. Same size chisel and bit must be used together. State size.  
**9 P 2420**—Hollow Chisel. Sizes, 1/4 in., 3/8 in., and 1/2 in. Shipping weight, 4 oz.....\$1.45  
**9 P 2422**—Mortising Bit. Sizes, 1/4 in., 3/8 in., 1/2 in. Shipping weight, 4 oz.....\$1.25

COMPANION Drill Press equipped with idler assembly

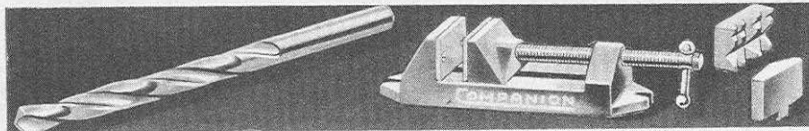

## CRAFTSMAN Twist Drills

Use carbon steel for slow speed drilling; high speed steel for electric drills and drill presses.

Diam. In.	Shpg. Wt.	9P6698 9P6699		Diam. In.	Shpg. Wt.	9P6698 9P6699	
		Carbon Steel	High Speed Steel			Carbon Steel	High Speed Steel
1/16	1 oz.	8c	18c	7/32	1 oz.	14c	35c
3/64	1 oz.	9c	19c	1/4	2 oz.	17c	41c
1/32	1 oz.	9c	20c	5/16	2 oz.	23c	59c
1/16	1 oz.	9c	21c	3/8	3 oz.	28c	.....
3/64	1 oz.	10c	22c	7/16	3 oz.	32c	79c
1/32	1 oz.	10c	23c	1/2	4 oz.	45c	.....
3/64	1 oz.	10c	25c	5/8	5 oz.	65c	.....
1/16	1 oz.	11c	29c	3/4	5 oz.	.....	.....

## COMPANION Drill Vise

Increase the range of work your drill will handle with this high quality vise. Priced at one-third what is usually asked for similar quality vises. Strongly built. Complete with two extra jaws, one for round or irregular work and swivel block jaw for tapered pieces. Oxidized, non-rusting finish. Accurately cut screw with knurled end for fast action and bar for locking. Over all length, 10 1/2 inches. 2 7/8-inch jaws open 3 inches. Extra jaws included. You can hardly get along without it for handling tapered pieces and round objects such as pipe, rod, etc.

**9 P 2436**—Shipping weight, 4 pounds.....\$1.85

## Hold-Down Guide and Bracket

This accessory is indispensable in mortising, as it prevents the work from being lifted when chisel is raised. Adjustable guide insures straight line mortises. Guide is also handy for straight line routing. Shipping weight, 6 pounds 6 ounces.

**9 P 2457**—Hold-Down Guide and Bracket for Mortising.....\$1.90

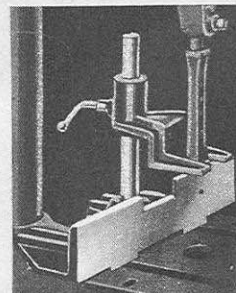
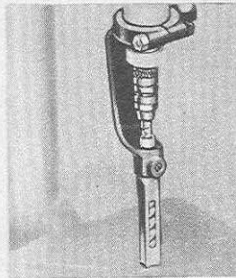

# CRAFTSMAN ALL-PURPOSE

REG. U. S. PAT. OFF.

## Users Agree It's the Biggest Value in

Use the CRAFTSMAN All-Purpose Drill Press and know the satisfaction of producing fine mouldings, square or rectangular holes, dovetail joints, etc.,—smoothly, easily, and with precision. Know, too, the year-after-year service assured by CRAFTSMAN'S modern design and sturdy, tested construction.

Sears floating drive removes drill press vibration, which sometimes occurs at high speeds, by getting at the cause. One of the principal causes of this vibration has been the side-pull of the belt on the spindle. In Sears drive the pulley is mounted on a long steel sleeve which is in turn mounted on a double-row SKF ball bearing accurately fitted into the drill head . . . mounted independent of the spindle the pulley *transmits no side-pull to it!* This basic CRAFTSMAN improvement produces drill presses that stand out because of their smooth, efficient performance.

Widen the usefulness of your CRAFTSMAN Drill Press with the accessories below. You can actually produce more than 50 different shapes of moulding edges with Sears shaper cutters. Be sure you get a drill that will perform *extra services*, a drill that will turn out the professional type of work that's a joy to the true craftsman. Notice the fine equipment for hollow chisel mortising (cutting square holes), for making dovetail joints, for doing routing, carving, inlay work, etc. You'll find the CRAFTSMAN handles these jobs so easily that it will be your favorite tool.

### ACCESSORIES FOR SHAPING OPERATIONS ON DRILL PRESS

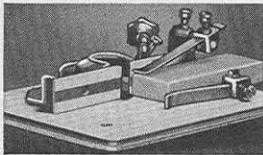

#### Shaping Attachment

Large, 14½x18-inch finely finished plywood table, fitted with adjustable guard and guide. With hold-down clips and fittings. Shipping weight, 17 pounds.

9 P 2430—Complete attachment for drill press. . . \$7.95  
 9 P 2428—Guard and guide only. Shipping weight, 4 pounds 12 ounces. . . \$2.85  
 9 P 2455—Spring clips only. Shpg. wt., 3 lbs. 14 oz. . . \$1.65



Adapter for 3/8-in. bore cutters shown on Page 10. Shpg. wt., 7 oz. 9P2434 \$1.25  
 Adapter for 1/2-in. bore shaper cutters at right. Shpg. wt., 7 oz. 9P2435 95c

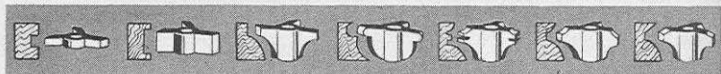

9 P 2319 1/4-inch Shaper Cutter 85c  
 9 P 2321 1/2-inch Shaper Cutter 85c  
 9 P 2323 1-inch Shaper Cutter 95c  
 9 P 2325 1-inch Shaper Cutter 95c  
 9 P 2327 1-inch Shaper Cutter 95c  
 9 P 2329 1-inch Shaper Cutter 95c  
 9 P 2331 Table and Rule Joint Bead Cutter 95c

Sizes given are height of cutter. Shipping weight of all items above is 4 ounces.



Adapter for sash cutter. Shipping weight, 6 oz. 9P2437 \$1.25  
 Sash cutter. Shipping weight, 4 oz. 9P2438 \$1.45  
 Adapters must be mounted as shown below and must be locked with knurled collar.



9 P 2333 Straight Face Cutter 95c  
 9 P 2335 Table and Rule Joint Cove Cutter 95c  
 9 P 2365 Matched Set Tongue and Groove Cutters \$1.85  
 9 P 2367 Guide Collars, 1/2-inch hole. \$1.29  
 9 P 2433 Adapter for small cutters 35c  
 9 P 2465 Cutter Lock Nut 7c

Shipping weight of all items above is 6 ounces.

### ACCESSORIES FOR DOVETAILING AND MORTISING

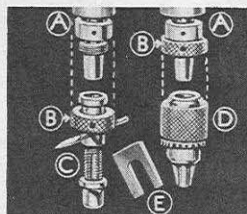
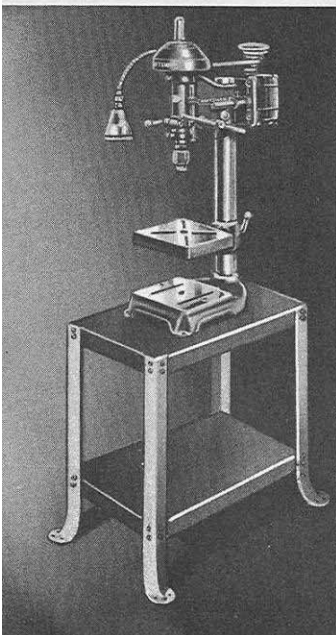

#### Finest Quality Tapered Spindles

Permanently installed in drill by master mechanics to run true, stay accurate. Lower end of spindle (A) is tapered below threaded part to handle all accessories. Wedge (E) may be used to remove chuck (D). Knurled ring (B) is threaded inside; fits on outside of collet chuck or shaper adapter (C), securely locks them in position.

← **Machine Stand**  
 Strong, rigid, all-metal stand for CRAFTSMAN Drill Press. Top 16x21 inches, 31 inches high. Tool shelf. Shipping weight, 39 pounds. 99 P 2746 . . . \$5.65

**Tool Light**  
 Especially for power tool use. Fits drill press. Throws light exactly where wanted—not in your eyes. Has 15-in. flexible neck, reflector, cord and plug. Shipping weight, 1 lb. 12 oz. 9 P 2264 . . . \$1.60

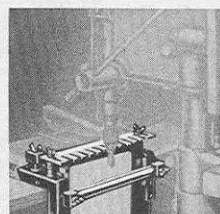

#### Dovetailing Attachment

With this attachment you can make perfect dovetail joints. Both members are cut at the same time. Attachment includes a steel comb, slotted to guide shank of router cutting to a pre-determined depth, end plates together with screw fittings for attaching the above guide or comb, clamps for holding work, and a 1/2-inch dovetailing router. Wood parts are not supplied. Ends of pieces to be dovetailed are held at right angles in clamp so that cutter may be guided through one piece and into the other. U. S. Patent Number 1651510 Shipping weight, 4 lbs. 1 oz.

9 P 2462—Dovetail attachment set and instructions. . . \$1.98

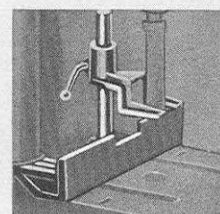

#### Hold-Down Guide

Indispensable in mortising as it prevents the work from being lifted when chisel is raised. Adjustable for thick or thin material. Keeps the work lined up and mortises straight. Bolts to regular drill press table. Easy to use. Fence part can be used without hold-down as a guide in routing, inlay work, etc. Heavy gray iron construction. Sturdy polished clamp on hold-down. Fingers on hold-down are long enough to securely hold work. Can be used on 99 PM 2380 (on opposite page) and 99 PM 2407 or 99 PM 2392 (on Pages 28-29). Shipping weight, 6 lbs. 6 oz.

9 P 2457—Hold-Down Guide and Bracket for Mortising. . . \$1.90

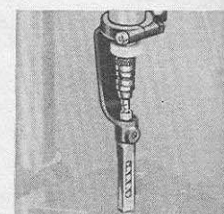

#### Hollow Chisel Mortising

Mortising housing carries the hollow chisel. Mortising bit is carried in collet chuck and revolves. Bit drills a round hole and chisel cuts off corners to make a square hole.

9 P 2461—Mortising Chisel Housing. Mounts on quill of drill press. Used with collet chuck, chisels and bits listed below. Shipping weight, 3 pounds. . . \$1.50  
 9 P 2450—Collet chuck for tapered spindle. Shipping weight, 6 ounces. . . 89c  
 9 P 2420—Hollow Chisel for 9P2461, 1/4, 3/8, and 1/2-in. State size. Shpg. wt., 4 oz. . . \$1.45  
 9 P 6458—Mounted Grinding Point for sharpening hollow chisels. Shpg. wt., 3 oz. . . 48c  
 9 P 2422—Mortising Bit for 9 P 2461. Sizes, 1/4-in., 3/8-in., 1/2-in. State size. Shipping weight, 4 ounces. . . \$1.25

# DRILL PRESS

## Drill Press History

- The only Drill Press near this low price with both ball bearings and Jacobs' chuck—These are two important features.
- Full-floating spindle—any side-pull from belt on spindle is carried on a large, deep-groove, two-row SKF ball bearing.
- 5/8-in. six-splined spindle mounted in quill entirely independent of pulley mounting on two more sets of SKF ball bearings.
- Smooth, vibrationless performance—even at high speeds.
- Drills to center of a 12 3/4-inch circle.
- Smooth, uniform feeding assured by heavy ground steel quill with integral accurately cut teeth. Feather touch quill lock is provided.
- New table with diagonal slots can be tilted to any angle.
- External depth gauge has knurled lock nuts and is graduated in 16ths of an inch. Depth gauge construction eliminates side-play in quill.
- Machine base serves as auxiliary table. Slotted for attachments.

### SPECIFICATIONS

Over-all height: 36 inches.  
 Over-all width: 10 3/4 inches.  
 Over-all depth with motor: 24 inches.  
 Chuck: Jacobs' geared type. 1/2 to 1/2-in. capacity.  
 Maximum distance, table to chuck jaws: 11 inches.  
 Spindle travel: 3 in. Spindle has six-splined drive.

Table travel: 11 inches.  
 Distance, chuck to base: 15 1/2 in.  
 Bearings: Deep groove SKF 3 sets, 4 rows of bearings.  
 Steel column diameter: 2 1/4 in.  
 Number of speeds: 9.  
 Speeds: 600, 760, 1000, 1300, 1800, 2400, 3300, 4000, and 5200 R.P.M.  
 Table size: 8 by 9 inches.

The CRAFTSMAN is an outstanding example of Sears amazing progress in drill press performance. Here's a machine that is really five machines in one. You can easily convert this press into an efficient spindle shaper—or use it for mortising, routing, sanding and dovetailing with equally fine results. As a shaper it will enable you to cut all kinds of mouldings—to add professional trim to your work. Hollow chisel mortising enables you to cut square holes. Craftsmen everywhere recognize mortised joints as a sign of fine workmanship. The same is true of dovetailed joints which can easily be cut with the proper attachments. Relief carving can be done on this drill. Inlay work can be handled with the proper cutters. We believe you will find it truly an "All Purpose" drill press.

From the tip of its spindle to the carefully machined base it represents top-notch value. It is built throughout of the finest materials, machined with painstaking skill. The genuine Jacobs' chuck supplied as standard equipment is the most accurate obtainable.

This drill press is equipped with full-floating ball bearing spindle for smooth, quiet operation. Three heavy duty deep groove SKF ball bearings are used. The two rows of bearings in the pulley bearing and two large single-row SKF ball bearings in the quill provide 4 rows of ball bearings and insure smooth operation. The quill is made of solid steel, accurately ground. The teeth for receiving feed pinion are milled into it. A quickly adjustable stop gauge indicates at all times the depth of holes being drilled.

99 P M 2380—CRAFTSMAN Drill Press, less motor. Complete with 1/2 to 1/2-in. Jacobs' chuck and key, endless "V" belt, and motor pulley. Shipping weight, 85 pounds. . . . . \$27.95  
 99 P M 2385—Same as above but with 1/2-H.P. ball bearing double shaft motor No. 99 P 5607. See Page 43. Shpg. wt., 112 lbs. . . . . \$37.45

Easy Terms!  
 ON ORDERS OF 20 OR MORE  
 -SEE INSIDE FRONT COVER

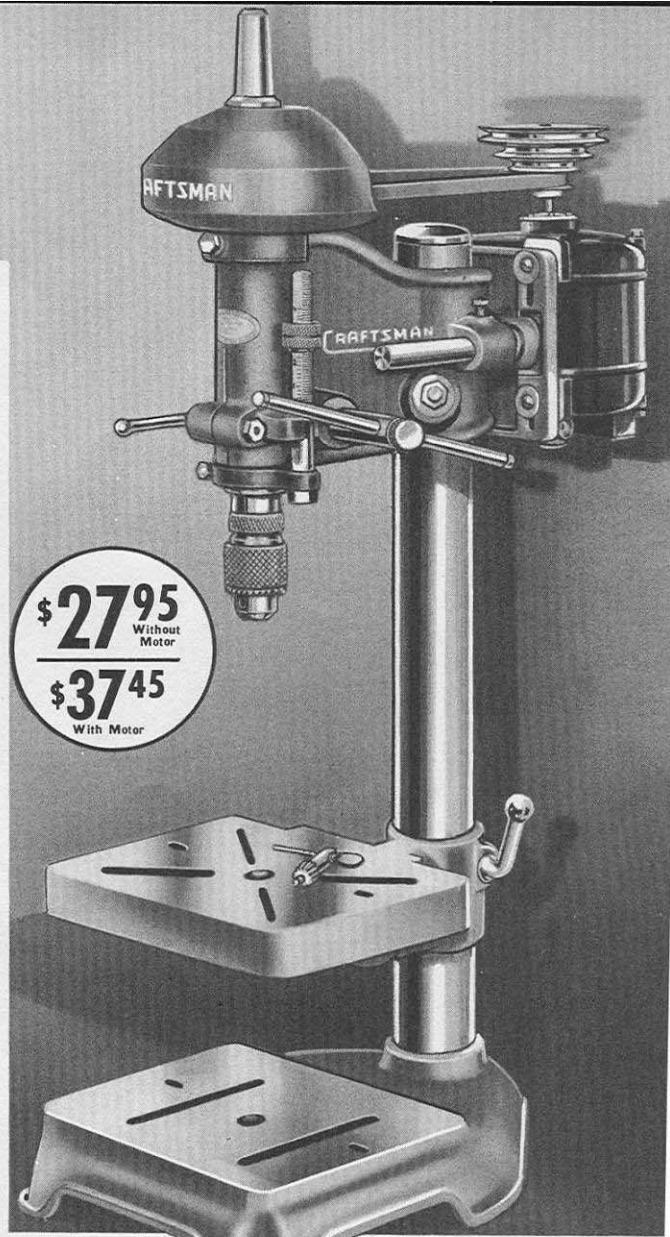

### CRAFTSMAN Twist Drill Sets

Highest quality twist drills in handy wooden box. Fast drilling—long lasting. Seven sizes in each set; 1/16, 1/8, 3/16, 1/4, 5/16, 3/8, 1/2 and 5/8 inch. Use carbon steel drills for slow speed drilling; high speed drills should be used in electric drills and drill presses. Shipping weight, 6 oz.  
 9 P 6685—Set of 7 Carbon Steel Twist Drills. . . . . 75c  
 9 P 6686—Set of 7 High Speed Steel Twist Drills. . . . . \$1.75



### COMPANION Drill Vise

Used to hold work on drill press table—gives greater convenience, accuracy. Particularly handy on small pieces. Oxidized, non-rusting finish. Accurately cut screw with knurled end for fast action and bar for locking. 2 3/8-in. wide jaws open 3 inches. Over-all length, 10 1/2 in. Complete with 2 extra jaws, one for round or irregular work, and swivel jaw for tapered pieces. Shipping wt., 4 lbs.  
 9 P 2436 . . . . . \$1.85

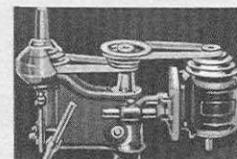

### Multi-Speed Attachment

For drilling metal which requires slow speeds or in routing which requires high speeds. (See chart at right.) Use 1/2 H.P. motor, 1750 R.P.M., for high speeds. 1/2 H.P. is adequate for regular and low speeds. U. S. Patent Number 2073704. Shipping weight, 5 pounds.  
 9 P 2397—Slow speed attachment and 2 Vee belts, ready to use. . . . . \$5.60

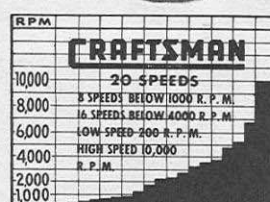

### Notice Speed Range!

The CRAFTSMAN Drill Press fitted with our patented multi-speed attachment at left will provide 20 different speeds ranging from 200 R.P.M. (half the speed of ordinary slow speed drills) to over 10,000 R.P.M. You'll have the RIGHT speed for any job. And that means better results!

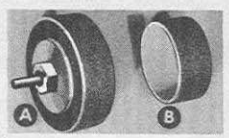

### Sanding Drum

(A) Use with collet chuck 9 P 2450 below. Also may be used with flexible shaft. All drums are 1 inch high. State diameter wanted.  
 9 P 2439—Shipping weight, each, 4 ounces.  
 1 1/2-inch diameter . . . . . 39c  
 2 3/8-inch diameter . . . . . 69c  
 3-inch diameter . . . . . 95c  
 (B) Replacement Sanding Sleeves. Fine or coarse grit. Package of 6. State grit and diameter.  
 9 P 2442—Shipping weight, each, 3 ounces.  
 1 1/2-inch diameter . . . . . 49c  
 2 3/8-inch diameter . . . . . 49c  
 3-inch diameter . . . . . 69c



- (A) 9 P 2450 Collet Chuck for tapered spindles 89c
- (B) 9 P 2400 1/4-inch Router 59c
- (C) 9 P 2401 3/8-inch Router 59c
- (D) 9 P 2402 1/2-inch Router 65c
- (E) 9 P 2403 3/4-inch Router 75c
- (F) 9 P 2404 1-inch Router 85c
- (G) 9 P 2405 1 1/2-inch Router 90c
- (H) 9 P 2409 1/4-in. Dove-tail Router 59c
- (J) 9 P 2410 3/8-in. Dove-tail Router 59c
- (K) 9 P 2411 1/2-in. Dove-tail Router 59c
- (L) 9 P 2415 1/2-in. Carving Router Bit 85c
- (M) 9 P 2416 3/4-in. Carving Router Bit 85c

Shipping weight of each cutter above is 6 ounces.

# CRAFTSMAN HEAVY DUTY DRILL PRESS

## WITH SEARS EXCLUSIVE

- Spindle drive pulley is mounted on steel sleeve which rotates on two SKF deep groove ball bearings mounted in head eliminating all transverse belt pull on spindle.
- 5/8-inch special steel spindle mounted in quill on two more precision type SKF deep row heavy duty ball bearings.
- Perfectly balanced automobile type splined drive spindle transmits a smooth even flow of power.

**\$35<sup>90</sup>**  
Less Motor  
**\$45<sup>40</sup>**  
With Motor

WHAT IS "FLOATING DRIVE"? In the CRAFTSMAN Heavy Duty Drill Presses presented on these pages, the drive pulley is mounted on a heavy tubular steel spindle which is supported on two sets of heavy duty deep-row ball bearings in the drill head—*entirely independent from the spindle*. This unit absorbs all side pull from the belt and transmits *only* a turning force to the spindle. The spindle itself is also mounted on two sets of heavy duty deep-row ball bearings within the quill as shown in the small illustration at left. This "Floating Drive" construction is a basic improvement that produces in CRAFTSMAN Heavy Duty Drill Presses the finest, smoothest, most accurate operation it is possible to obtain. Be sure the drill press you buy has it!

### SPECIFICATIONS: BENCH MODEL

See opposite page for other details of construction.

- |   |   |
|---|---|
| Drills to center of 15-inch circle.   | Over-all width: 11 3/4 inches.                        |
| Chuck: 0-1/2-in. Jacobs.  | Over-all depth: 24 inches.                            |
| Table size: 10x10 in.   | Maximum distance from table to chuck jaws: 13 in.     |
| Number of SKF heavy duty ball bearings: 4.  | Maximum distance base to chuck jaws: 19 inches.       |
| Number of speeds: 9; 600, 760, 1000, 1300, 1800, 2400, 3300, 4000 and 5200 R.P.M. | Spindle: travel, 4 inches; 6 automobile type splines. |
| Over-all height: 41 inches.   | Diameter of column: 2 3/4 in.                         |
|   | Table travel: 13 inches.                              |

Use 1/2-H.P. motor for ordinary work; 1/2-H.P. for production work.

**99 PM 2407**—CRAFTSMAN Heavy Duty Bench Model Drill Press with motor pulley, belt and 0 to 1/2-in. Jacob's chuck. New type quill return, etc. Shpg. wt., 115 lbs. .... **\$35.90**

**99 PM 2388**—CRAFTSMAN Heavy Duty Bench Model Drill Press, with motor pulley, belt and 1/2-H.P. 110-120-volt, 60-cycle A.C. motor. Shipping weight, 149 pounds. .... **\$45.40**

**Easy Terms!** ON ORDERS OF \$20 OR MORE SEE INSIDE FRONT COVER

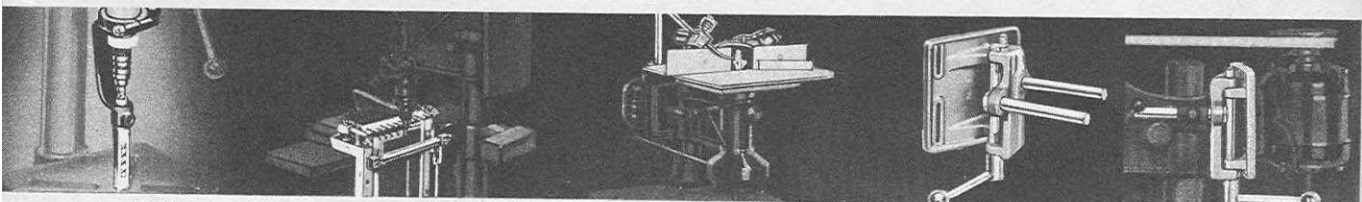
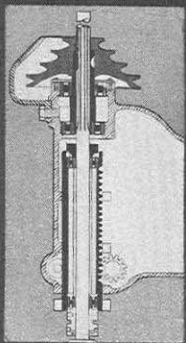

### Hollow Chisel Mortising

For fine cabinet work and joinery. Cut accurate mortises quickly with perfectly square ends, or drill square holes.

**9 P 2461**—Mortising chisel housing for drill press. Shipping weight, 3 pounds. .... **\$1.50**

**9 P 2420**—Hollow chisels for use with 9 P 2461 attachment. Highest quality. Sizes 1/4, 3/8, and 1/2-in. Specify size. Shipping wt., 4 oz. .... **\$1.45**

**9 P 6458**—Stone for sharpening above chisels (illustrated on Page 23). Shipping weight, 3 oz. .... **48c**

**9 P 2422**—Mortising bit for use with above attachments. Highest quality. Sizes 1/4, 3/8 and 1/2-in. Specify size. Shpg. wt., 4 oz. .... **\$1.25**

### Dovetailing Attachment

By using the attachment shown above you can cut dovetails that make perfect joints because you cut both members simultaneously. Attachment consists of a comb, slotted to guide shank of router cutting to a predetermined depth. End plates together with screw fittings for attaching the above guide or comb and clamps for holding work, and a 1/2-in. dovetail router are included. Wood parts not included. Patent number 1651510.

**9 P 2462**—Dovetail attachment. Set complete with router and instructions. Shipping weight, 4 lbs. 1 oz. .... **\$1.98**

### Shaping Attachment

You can convert your CRAFTSMAN Heavy Duty Drill Press into a spindle shaper by inverting the head bracket and motor assembly, placing the new and improved extension table over it. This new type shaping attachment can also be used with the drill head in its normal position. For detailed illustration of guard and guide and for cutters of various shapes see Page 26.

**9 P 2430**—Extension table for spindle shaping. With guard guide and spring clips. 14 1/2 x 18 in. Shpg. wt., 17 lbs. .... **\$7.95**

**9 P 2435**—Shaping adapter for 1/2-in. bore cutters. Shpg. wt., 7 oz. **95c**

### CRAFTSMAN Drill Press Belt Tension Release

This handy attachment fits on our CRAFTSMAN drill press and replaces the regular motor base. A pivot is provided so that it is possible to swing the entire motor in towards the head, thus releasing the tension on the belt. This is done by throwing a single lever. In this way it is possible to have perfect tension on your belt at all times and yet quickly release this tension in order to change speeds. A very practical idea which will more than pay for itself in convenience. No credit for return of old motor base. This belt release requires a special length of V belt which is listed below. Shpg. wt., 12 lbs.

**9 P 2366**—Belt release for 99 PM 2380, 99 PM 2407 and 99 PM 2392 CRAFTSMAN Drill Press, less belt. .... **\$3.45**

**9 P 2757**—1/2-inch by 45-inch V belt for use of belt release with any of above mentioned drill presses. Shipping weight, 7 ounces. .... **49c**

# DUTY DRILL PRESSES

## "FLOATING DRIVE" FEATURE

- New ratchet adjustment allows you to adjust quill for light or heavy work.
- Genuine 0 to 1/2-inch Jacobs' key chuck.
- Drills to center of 15-inch circle.
- 9 speeds from 600 to 5200 R.P.M. More with multi-speed attachment.
- Heavy steel tube column, 2 3/4-inch diameter
- Graduated depth gauge is milled flat and prevents rotational play in quill.
- Table may be tilted to any desired angle.
- Improved table with diagonal slots to simplify adjusting attachments. Base is also slotted for securing attachments, fixtures, jigs, etc.

On these two pages you will find Sears finest drill presses—marvels of precision construction and smooth, vibrationless operation. Many improvements and refinements of design have been added in these new 1939 models.

Newly designed ratchet adjustment makes it easy to regulate quill return in just a few seconds for light or heavy work. Spring tension can be varied instantly by turning the spring box, thus tightening the spring. Spring box is held by a ratchet device. A release button is provided to release the ratchet and reduce the spring tension. The new tempered steel spring is made almost twice as large as ordinary springs used for this type of drill press in order to assure long life.

The table is newly designed with diagonal slots to simplify adjusting attachments. Drive spindles are splined like the drive shaft of your automobile. Accurate, easily-read depth gauge is graduated for entire 4-inch feed range in 1/16-inch divisions. The depth gauge is also provided with knurled stop nuts. Efficient quill lock holds quill securely for routing and carving operations. Carefully machined table may be tilted to any angle.

For the shop having a production problem that only a really high grade drill press will solve . . . we recommend these CRAFTSMAN Heavy Duty Drill Presses. Use 1/3-H.P., 1750 R.P.M. motor for ordinary work and 1/2-H.P., 1750 R.P.M. motor for production work.

- 99 PM 2392—CRAFTSMAN Heavy Duty Floor Type Drill Press, with motor pulley, belt and 0 to 1/2-in. Jacob's chuck. With standard pulley guard such as shown on number 99 PM 2407 on opposite page. Without motor. Shipping weight, 150 pounds . . . . . \$39.95
- 99 PM 2393—Same as 99 PM 2392 above but with 99 P 5607 COMPANION 1/4-H.P. ball bearing 110-120-volt, 60-cycle A.C. motor. (See page 43). Shipping weight, 180 pounds . . . . . \$49.45
- 99 PM 2399—Same as 99 PM 2392 but equipped with new streamlined belt and pulley guard. Without motor. Shpg. wt., 159 lbs. . . . . \$48.70
- 99 PM 2390—Same as 99 PM 2392 but equipped with new streamlined belt and pulley guard and COMPANION 1/4-H.P. ball bearing 110-120 volt, 60-cycle A.C. motor. Shipping weight, 198 pounds . . . . . \$57.95
- 9 P 2398—Belt and Pulley Guard. This guard is made from aluminum and is hinged at the side to make belts and pulleys accessible for speed changing. Required by many industrial safety codes. Fits bench or floor model, offers a high degree of safety. Shipping weight, 9 pounds . . . . . \$9.00
- 9 P 2429—Collar for CRAFTSMAN drill presses on Pages 28 and 29, or any drill with a 2 3/4-inch column. This collar locks on column under head. Supports the head when clamp on head is released. Makes it easy to swing the head around for working at different points over the table. Shipping weight, 4 pounds 8 ounces . . . . . \$1.45

**Easy Terms!**  
ON ORDERS OF 20 OR MORE  
SEE INSIDE FRONT COVER

### SPECIFICATIONS Floor Type Model

- Over-all height: 71 inches.
- Over-all width: 18 inches.
- Over-all depth: 30 inches.
- Maximum distance from table to chuck jaws: 42 inches.
- Maximum distance from base to chuck jaws: 48 inches.
- Table travel: 41 inches.
- Base is slotted but not ground finish like table. All other specifications are identical with number 99 PM 2407 bench type model drill press on opposite page.

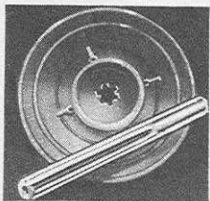

**6-Splined Drive Spindles**

Automobiles have long been driven by splined drive shafts because they transmit power smoothly, are free from excessive back lash and last longer. For these very same reasons all our drill presses have splined automotive type drive spindles. While more costly than the key and key-way type of drive the splined spindle produces results which more than repay this difference. Spindle and pulley illustrated above. The internal and external splines are both produced by the most accurate methods and of the best materials by experienced workmen.

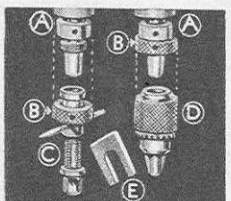

**Simplified Tapered Spindles**

These accurately made spindles are permanently installed in the drill by master machinists. With CRAFTSMAN construction there is no need to remove the spindle when changing chucks. This means greater accuracy, and accuracy over a longer period of time. The lower end of the spindle (A) is tapered. Such a taper will accommodate Jacobs' chucks, collet chucks, shaping adapters or other accessories. Wedge (E) may be used to remove chuck (D). The knurled ring (B) is threaded inside and must be used to lock shaper adapter (C) or collet chucks in place on the spindle.

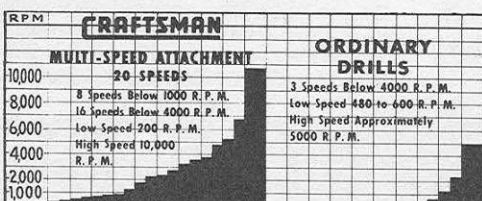

**Proper Drill Speed Available for Every Kind of Work**

Ordinary drill presses have from 4 to 7 speeds ranging from slightly over 500 R.P.M. to about 5000 R.P.M. The low speed is too high for 1/2-in. carbon steel drills when cutting metals. The top speed is not fast enough if much shaping or carving is to be performed. Drill presses called "slow speed" have a low speed of about 400 R.P.M.—not much slower than the regular drills.

The CRAFTSMAN drill press may be fitted with our patented multi-speed attachment which will provide 20 different speeds ranging from 200 R.P.M. (half the speed of ordinary slow speed drills) to over 10,000 R.P.M. See chart above.

Of these 20 speeds 8 are below 1000 R.P.M. and take care of slow speed requirements. There are 10 more speeds between 1000 R.P.M. and 10,000 R.P.M. This wide range of speeds will accommodate all specialty work, carving, shaping, etc.

This outstanding development is another evidence of Sears desire to more accurately serve their customers' requirements.

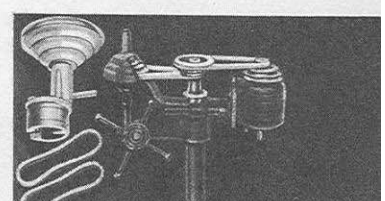

**Multi-Speed Drill Press Attachment**

The adaptability of CRAFTSMAN drills to a wide range of uses calls for a wide speed range. Slow speeds are essential for drilling in metal, and for hollow chisel mortising and certain other operations. On the other hand high speeds of 8,000 to 10,000 R.P.M. are desirable for routing, carving, shaping, etc.

The chart at left shows how the CRAFTSMAN multi-speed attachment (Patent number 2073704) enables you to get the most out of your drill.

Finest ball bearing construction, designed so belt tensions are easily adjusted. Complete with belts, etc., ready to use. We recommend a 1/2-H.P., 1750 R.P.M. motor if this attachment is to be used for high speed operation.

9 P 2394—Shpg. wt., 5 lbs. . . . . **\$5.75**

# AMERICA'S NEWEST POWER TOOL

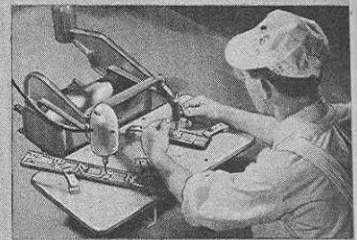

Professional craftsman reproducing a strip of moulding from an original design.

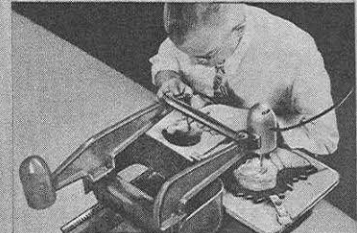

With the CRAFTSMAN Carver you can start with a photograph and produce a carved plaque.

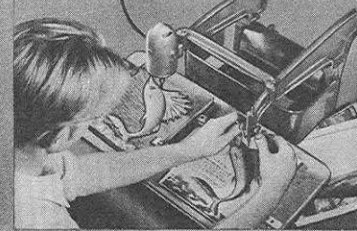

Easy to handle. Here's a carving being made from a picture torn out of a magazine.

## CRAFTSMAN CARVER OPENS AN ENTIRELY NEW FIELD FOR THE CRAFTSMAN

- Makes fine reproductions in wood of photographs, drawings or models.
- Powerful Universal Ball Bearing motor for 110-120 volt A.C. or D.C. (A.C. 25 to 60 cycles). Needs no oil; permanently lubricated at factory.
- Convenient toggle switch.
- Air blast keeps work clean.
- Mechanism perfectly balanced for easy, accurate operation.

Never before have craftsmen been able to buy a tool like this sensational new automatic carver at anywhere near this price! Now you can do wood carving easier, faster, BETTER! It's impossible to realize what a marvel this machine is until you use it yourself!

Plaques . . . panels . . . book ends . . . furniture-carvings . . . mouldings . . . drawings or photographs of ornamental designs . . . even photographs of your family or notable characters . . . all can be easily and accurately reproduced in wood with this efficient device.

HERE'S THE WAY YOU DO IT: Start with a model—a plaque for example—under the tracer pin on the right hand arm. As you trace the outlines and details of the plaque with the tracer pin, the cutter on the left hand arm follows the same pattern exactly. The arms move together sideways—back and forth—up and down—or in any intermediate motion at any angle. The design on the plaque is first roughed down and then finished up with very fine cutters to bring out all the fine details.

The machine is perfectly balanced to allow it to follow every detail of the model easily and accurately. Will handle wood up to 9x8½ inches at one setting of the model. Will handle any length if not more than 6 inches wide. 5-ply hardwood table is 23¾x11¼ in. Over-all height, 14½ inches. Complete with 6-ft. rubber covered cord and plug; all necessary clamps, screws, etc.; 2 chuck wrenches; chuck; 3 different size cutters; 2 tracer pins; a model and a piece of wood for carving. Patents applied for. Shpg. wt., 55 lbs.

99 P 2566—CRAFTSMAN Automatic Carver . . . . . \$38.50

Easy Terms! ON ORDERS OF \$20 OR MORE SEE INSIDE FRONT COVER

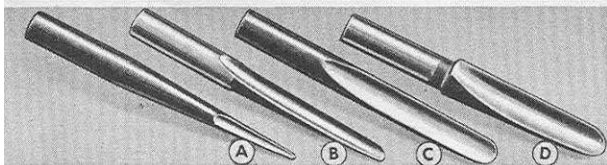

### Carving Cutters for Above Machine

High carbon steel, accurately ground and finished. The ⅝-<sup>16</sup>-inch shanks fit the collet chuck on the carver above. Available in four different sizes: ⅝-<sup>16</sup>, ⅜-<sup>16</sup>, ⅙-<sup>16</sup>, and ¼-<sup>16</sup> inch. The larger sizes are designed to be used for roughing down the work when starting. The medium sizes are designed to be used for bringing out the outline more accurately and carrying out the details. The small cutter is designed for very fine finishing and detail work.

- Ⓐ 9 P 2571—⅝-<sup>16</sup>-inch cutter. Shpg. wt., 2 oz. . . . . 35¢
- Ⓑ 9 P 2570—⅜-<sup>16</sup>-inch cutter. Shpg. wt., 2 oz. . . . . 35¢
- Ⓒ 9 P 2569—⅙-<sup>16</sup>-inch cutter. Shpg. wt., 2 oz. . . . . 39¢
- Ⓓ 9 P 2568—¼-<sup>16</sup>-inch cutter. Shpg. wt., 2 oz. . . . . 39¢

### CRAFTSMAN Wood Carving Tools

A set of five finely finished wood carving tools with 3¾-inch handles, 2½-inch blades. With these tools you can make an infinite variety of wood carvings. The blades are forged from a fine quality of steel, heat treated with the utmost care to take and hold a razor keen edge. Only Sears tremendous buying power and direct-to-you selling methods make this low price possible.

\$2.10 Set of 5

Complete set of 5 tools attractively boxed; includes one each of the following: ⅜-inch bent gouge, ⅜-inch bent chisel, ⅝-<sup>16</sup>-inch U tool, ⅝-<sup>16</sup>-inch straight chisel and a ⅝-<sup>16</sup>-inch veining tool. Shipping weight, 13 ounces.

- 9 P 2899 . . . . . \$2.10
- 9 P 2464—Set of 3 tools including a ⅝-<sup>16</sup>-inch U tool, ¼-inch skew bevel, and ⅜-inch bent chisel. Packed in a box. Shipping weight, 8 ounces. \$1.39

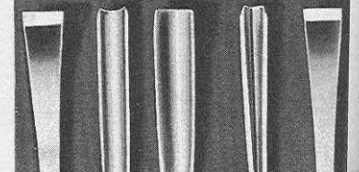
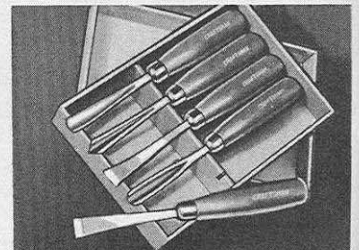

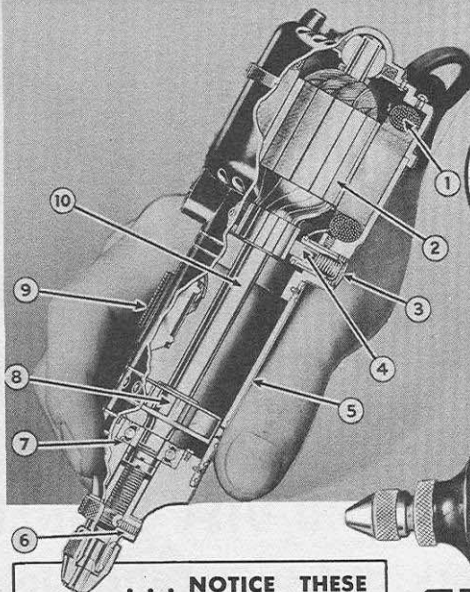

**\$14.50**  
Complete

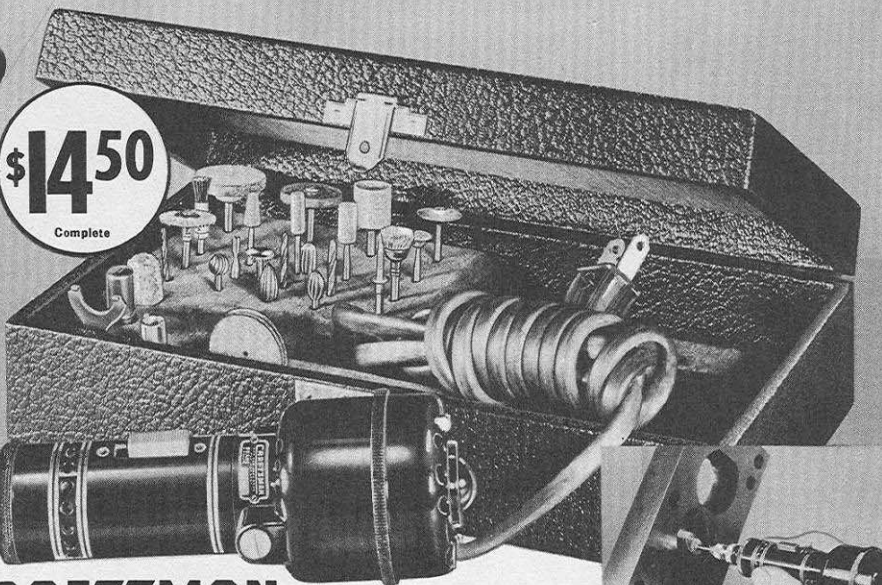

**... NOTICE THESE CONSTRUCTION FEATURES:**

- 1 Heavy field coils designed for extra power.
- 2 Perfectly balanced armature with built-up commutator.
- 3 Brush screw makes it easy to remove and replace brushes.
- 4 Motor brushes and springs.
- 5 Heavy shaft housing.
- 6 Holding collar on main spindle.
- 7 Grease-packed ball bearing.
- 8 Induction rotor 4-blade fan.
- 9 Bakelite switch control.
- 10 Brass spacer shell on spindle.

# CRAFTSMAN ROTARY ELECTRIC TOOL

Here's one of the most sensational values Sears have EVER offered in the power tool field! It took closest cooperation with the manufacturers to do it... It took our tremendous buying power as the largest distributor of power tools in the world... It took drastic slashing of profits... And now here it is—one of the most useful tools of this type ever designed, at a truly amazing price.

Notice that it has 50% more power than comparable units on the market! Notice how much easier it is to handle because of the smaller diameter in front of the motor. Notice the convenient toggle switch... the improved fan cooling system... the easily replaceable brushes... the long-life bearings... the EXTRA strength.

There are literally hundreds of different applications for this efficient tool... in every shop... in every tool room... in every line of industry. Use it for drilling, grinding, carving, polishing, engraving, sawing, sanding or routing. Use it on wood, metal, glass, or anything that can be machined. Use it for the hard-to-get-at places no other tool can reach. Tool and die makers and all metal working plants will find it indispensable for grinding and polishing every type of die. It sharpens knives, scissors, woodworking tools, lawnmowers, skates, and hundreds of other articles. It grinds all kinds of metal parts; is useful in external and internal grinding of gears. Carves all kinds of wood, plastics, etc.; is an ideal tool for pattern makers and wood carvers. May even be used to clean and polish jewelry and silverware, or to cut and engrave glass of all kinds.

Length, over all, including collet chuck, 7 inches. Extreme diameter, 2 inches. Complete with all the accessories shown at bottom of page, and in addition includes chuck wrench, collet chuck, socket wrench, emery wheel dresser, set of replacement brushes, one threaded mandrel, cord and plug, and heavy wood box. Shipping weight, 2 lbs. 10 oz.

- 9 P 2651—Complete set with accessories... \$14.50
- 9 P 2650—Rotary tool only. Shpg. wt., 1 lb. 8 oz.... 9.95

**Easy Terms**  
ON ORDERS OF \$20 OR MORE - SEE INSIDE FRONT COVER

- Does accurate drilling, grinding, carving, polishing, engraving, sawing, sanding, cutting, routing, etc.
- No-load speed, 15,000 R.P.M.
- More power than comparable units.
- Powerful Universal motor for 110-120 volt A.C. or D.C. (A.C. 25 to 60 cycles).
- Precision ball bearing in front.
- Self-aligning rear bronze bearing.
- Collet chuck takes 1/8 or 3/32-inch shanks.
- 26 accessories, including 6 grinding stones, 5 formed carving cutters, 3 drills, and various brushes, saws, polishing accessories, etc.



**STA-SHARP Whittler**  
Here's a well-made 4-blade knife at a very low price. Actually a 75c value! Has screwdriver—cap lifter blade; large spear blade; carving blade; and leather punch. Unbreakable stag type handle. Nickel silver bolsters. 3 1/2 inches long. Shipping wt., 4 oz.  
9 P 9491..... 39c

**STA-SHARP Carver**  
A \$1.49 knife if you ever saw one! Designed by an expert wood carver. High carbon blades are ground to razor-like fineness. Nickel silver linings and bolsters. Pen, Sloyd and bevel ground spear blade. Unbreakable stag type handle. 3 3/4 inches long. Shpg. wt., 3 oz.  
9 P 9511..... 85c

Tool and die makers will find this tool unequalled for grinding dies, etc.

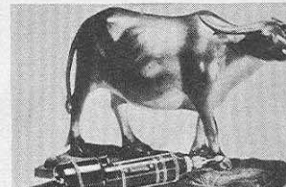

Wood carving is done easier, faster, and BETTER with this tool.



Use it on all kinds of materials, including metals, wood and glass.

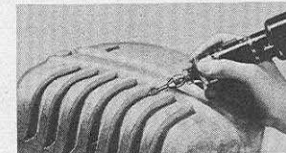

Ideal for pattern makers and wood carvers. Carves wood, plastics, etc.



- A 9 P 2653—Mounted red emery wheel, 1-in. x 1/4 in. .... 29c
  - B 9 P 2654—Mounted red emery wheel, 1/2-inch diameter; 1/2 inch long. For general grinding. .... 29c
  - C 9 P 2655—Rubber bonded wheel for polishing, 3/8 in. wide; 1/4 in. thick; 1/4 in. hole. .... 10c
  - D 9 P 2656—Saw, .050 thick; 3/8-in. diam.; 1 1/2-in. mandrel. .... 69c
  - E 9 P 2670—Oblong cutter, 3/16 in. diam.; 3/8 in. long. .... 55c
  - F 9 P 2671—Ball cutter. Diameter, 7/32 inch. .... 55c
  - G 9 P 2672—Cone cutter. Diameter, 7/32 inch. .... 55c
  - H 9 P 2673—Oval cutter. Diameter, 7/32 inch. .... 55c
  - J 9 P 2674—Flat Cutter. 3/32 in. diam.; 3/16 in. long. .... 55c
  - K 9 P 2675—Mounted emery wheel, 3/16 in. diam. .... 29c
  - L 9 P 2676—1/4-inch taper mounted red emery wheel. .... 29c
- Shipping weight of all accessories above and below, 2 oz. each.



- A 9 P 2677—Mounted red emery wheel, 3/16-in. diam., 1/2 in. long. 29c
- B 9 P 2678—Mounted red emery wheel, 1/4-in. diam., 1/2 in. long. 29c
- C 9 P 2679—Gray bristle brush, 3/4-inch diameter. .... 10c
- D 9 P 2680—Taper silver gray cup bristle brush, 1/2-in. diam. .... 10c
- E 9 P 2681—Mounted porte polishing brush, 3/16-in. diam. .... 10c
- F 9 P 2682—Knife edge rubber wheel, 3/8-inch x 3/2-inch taper wheel; 3/16-inch hole. .... 10c
- G 9 P 2683—4 carborundum discs, 1-inch diameter. 1/2 inch thick; 1/16-inch hole. .... 10c
- H 9 P 2684—High speed drill, 1/16-in. diam.; 1 3/4 in. long. .... 19c
- J 9 P 2685—High speed drill, 1/32-in. diam.; 1 3/4 in. long. .... 18c
- K 9 P 2686—High speed drill, 1/8-in. diam.; 1 3/4 in. long. .... 19c
- L 9 P 2687—Buffing wheel, 1-inch diameter. .... 10c

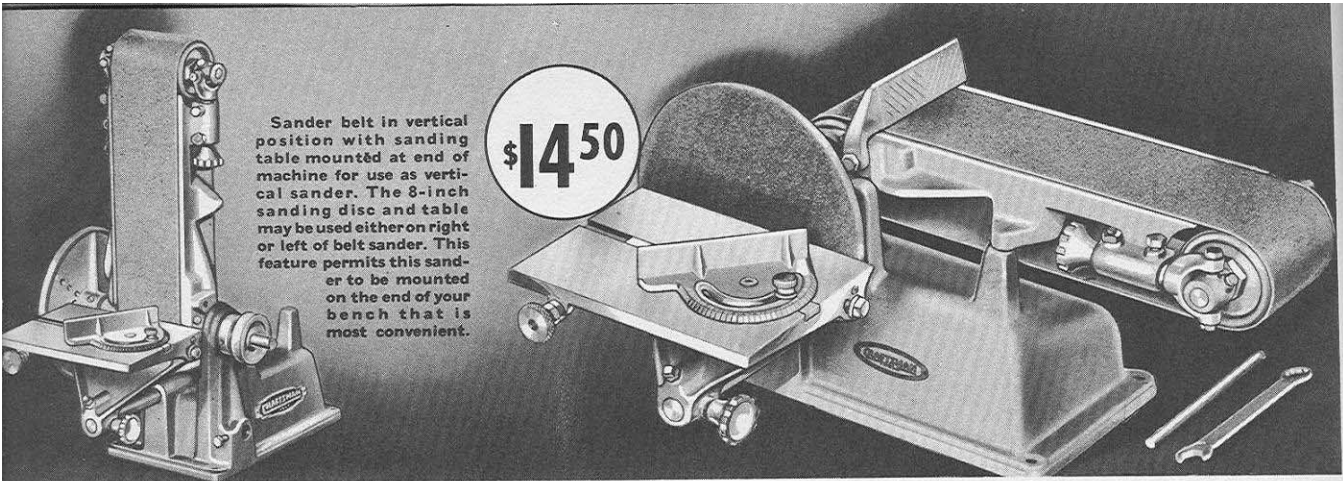

Sander belt in vertical position with sanding table mounted at end of machine for use as vertical sander. The 8-inch sanding disc and table may be used either on right or left of belt sander. This feature permits this sander to be mounted on the end of your bench that is most convenient.

**\$14.50**

## CRAFTSMAN BELT AND DISC SANDER

### Will Save You Work and Do a Better Job

- Belt sander mounts horizontally, vertically or at any angle. Ideal for finishing flat work, edges, etc.
- Disc sander table tilts to any angle up to 45° enabling you to sand mitred edges accurately.
- Disc sander and table easily removed to clear large work on belt.
- Extra long auto-lubricating bronze bearings for smooth operation.
- Quick acting adjustments to make belt run true between drums.
- Disc sander finishes curved work, end grains, etc. which cannot be reached by belt sander alone.
- Complete with 8-in. abrasive disc, 4-in. sanding belt and instructions.

Once you use a sander in your shop you'll never be without one. It not only takes the work out of one of the hardest jobs in woodworking—sanding—but it is very handy in fitting up and assembling jobs. It can cut so much faster than hand sanding that it actually does part of the work you would otherwise do on other machines. Practical operators say that they start the sander twice as frequently as any other tool in the shop.

We believe the CRAFTSMAN sander is superior to anything we have seen selling up to \$25.00. Its practical features and quality construction carry it ahead of the field. For ordinary work a 1/2-H.P. motor, 1750 R.P.M. is sufficient. For production operation we recommend 1/2-H.P. motor. Recommended operating speeds: 1200 to 1600 R.P.M. Shpg. wt., 42 lbs. 99 PM 2213.....\$14.50

Easy Terms ON ORDERS OF \$20 OR MORE SEE INSIDE FRONT COVER

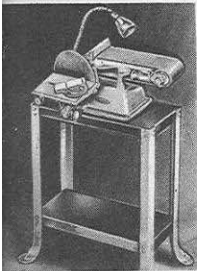

#### COMPANION Machine Stand

All metal machine stand. Has 10x21-inch top for mounting your combination disc and belt sander. 31 inches high. Shelf provided for motor. Shipping weight, 33 pounds. 99 P 2744.....\$4.85

#### COMPANION Tool Light

Extra large reflector throws light on your work, not in your eyes. Has 15-in. flexible neck, reflector, cord and plug. See Page 24. Shpg. wt., 1 lb. 12 oz. 9 P 2264.....\$1.60

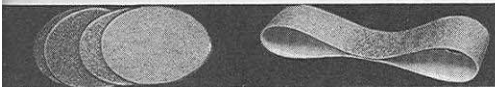

#### Abrasive Discs and Belts

Sanding Discs. Package of 6 assorted fine, medium and coarse. Shipping weight, 8 ounces. 9 P 2216—Garnet abrasive, for use on wood.....35c  
9 P 2217—Aluminum oxide abrasive, for use on metal. 39c  
Sanding Belts. For 99 PM 2213 Sander, 4 in. x 36 in. State grit desired, fine, medium or coarse. Shpg. wt., ca. 4 oz. 9 P 2218—Garnet abrasive, for use on wood. Each.....29c  
9 P 2219—Aluminum oxide abrasive, for use on metal. Each.....29c



## CRAFTSMAN

### HEAVY DUTY BELT AND DISC SANDER SKF Ball Bearings

- Four highest quality, dust-sealed SKF ball bearings.
- 10-in. balanced sanding disc. 12x6-in. adjustable disc sanding table. Tilts 90° to 45°. Quadrant indicates angle.
- Distance between drum centers is 18 inches. Sanding belt is 4 inches wide.
- 12x4 1/2-in. sanding table under belt. 8 1/2x6-in. table above belt; tilts 90° to 45°; has indicator and stop.
- Either upper or lower surface of sanding belt may be used—lower surface for stroke sanding operated with pressure block.
- Three speeds for cutting different materials. Belt speeds: 1050, 1760, and 3100 feet per minute.
- Single control regulates belt tension.

Here's a practical production tool—ideal for pattern shops and similar applications. Handles all kinds of surfacing jobs, before or after assembly. Will surface wood, metal, moulded plastics, fiber, cork, bone, etc. Will sand mitred edges with extreme accuracy. Both shafts run on dust-sealed ball bearings. Heavy cast iron base. 3 speeds available. Pulleys are accurately balanced aluminum die castings 5 inches in diameter. Sanding belt alignment easily controlled by pivoted bracket with knurled adjusting and lock nuts. Belt tension varied by cushion spring control. Over-all length, 26 inches; over-all height, 18 inches. For ordinary work use 1/2-H.P. motor, 1750 R.P.M. For heavy work, 1/2-H.P. motor, 1750 R.P.M. Recommended operating speeds: 765, 1350, 2275 R.P.M. With 10-inch abrasive disc, 4-in. sanding belt. For motors, see Pages 42 and 43. Shipping weight, 85 lbs. 99 PM 2210.....\$28.95

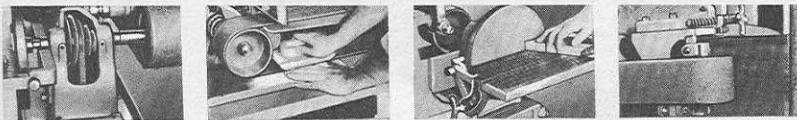

#### HERE'S EFFICIENCY FOR YOU!

Note sturdy ball bearing construction and 3-speed pulley which may be driven from below or behind. Drive pulley is covered by hood for maximum safety.

"Stroke surfacing." Lower surface of belt is pressed against work, allowing large pieces to be handled. Large diameter of sanding belt drums makes this possible.

Disc sander finishing a compound miter joint to mirror smoothness in a few seconds. This is a difficult operation without a sander, but easy on the CRAFTSMAN.

Belt tension unit—spring cushioned and adjustable. Belts are easily changed. Only necessary to use one control to change the tension or to remove the belt.

#### Abrasive Discs

Package of 6 assorted fine, medium and coarse sanding discs. For use on wood or metal. Shipping weight, 9 oz. 9 P 2206—Pkg. of 6.....59c

#### Abrasive Belts

Fine, medium or coarse. State grit wanted. For use on wood or metal. Shipping weight, 4 ounces. 9 P 2211—Each.....49c

# NEW COMPANION JIG SAW

Designed for Smooth, Faster Cutting

- 15-in. depth of throat. Cuts to center of 30-in. circle. Cuts up to 1½-in. thickness.
- Large table, 10x10 inches, tilts on double support. Locks rigidly at any desired angle with convenient handle.
- Perfectly balanced action reduces vibration; permits finer, faster cutting.
- Dustproof, oiltight crankcase for longer life—better service.
- Attractive streamlined frame, ruggedly built. Full length base support.
- Extra long bearings, carefully fitted. Auto-lubricating bronze main bearing.
- Built-in sawdust blower keeps work clean, and cutting lines visible.
- Cuts light or heavy wood. Will cut light metal.

## Vibrationless! Fast Cutting!

You'd never expect to find such materials—workmanship—smooth operation—and downright fine quality in a jig saw in this price range! But here it is—another example of Sears record-smashing values in the power tool field—another reason why Sears continue to lead the world in power tool sales! It's built strong enough for professional work—that's why it handles the usual run of homecraft jobs so easily. Scroll sawing, jig sawing, pattern making, toy building and similar types of work are easily handled by this machine.

The finely balanced mechanism runs in a bath of oil just like your automobile engine. Sturdy new type jaws accommodate practically all kinds of jig saw blades. If you want to saw copper or aluminum as well as wood—go ahead. With the proper blades you can handle light metals easily. The streamlined gray iron frame is very strong and rigid, with the base extending the entire length of the machine to give firmer and more solid support. This means a jig saw that will run smoother, more accurately. Notice the shipping



**\$11.95**

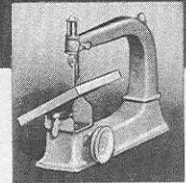

**View Showing Table Tilted**

Table is adjustable from 90 to 45 degrees. Note the double table support for greater firmness and rigidity. Scale shows angle of tilt. Quickly and easily locked at any angle.

weight of this saw—it's built heavily for long life and freedom from vibration. Easily handles stock up to 1½ inches thick. Has full 15-inch throat. Fitted with large 10x10-inch tilting table, adjustable from 90 to 45 degrees. Equipped with hold-down for work and guide for blade. There's nothing skimped—nothing omitted that would make this saw work better, do more, last longer! No doubt about it—it's the finest medium-size jig saw you've ever seen. Shipping weight, 45 lbs.

99 P 2255 .....\$11.95

**Easy Terms!** ON ORDERS OF \$20 OR MORE SEE INSIDE FRONT COVER

# COMPANION II-INCH JIG SAW...Runs in Bath of Oil

- 9-inch square gray iron table tilts to 45 degrees on double supports.
- Finely balanced mechanism operates in an oil-tight crankcase similar to that in your automobile.
- Sawdust blower. Bridge truss type frame.
- 11-inch throat. Cuts stock up to 1 inch thick.

It's built right—not built to meet a price but built to incorporate the important features of Sears larger jig saws. Check these quality features before you buy: Large table, 9x9 inches, is made of gray iron, ground to a perfect finish. Improved table tilting support carries table at two points, front and rear—makes table more rigid and sawing more accurate. The mechanism runs in a bath of oil as in the most expensive jig saws. This means smoother operation—longer life—greater all-around satisfaction. It cuts to the center of a 22-inch circle and easily handles stock up to 1-inch thick. Its balanced mechanism provides smooth operation.

Be sure the jig saw you buy has all these features. Then make the final test—operate it! That's the way to compare it! See for yourself how much finer this Sears saw is than any other jig saw sold at anywhere near its price! Shipping weight, 20 pounds.

99 P 2259 ..... \$5.75

**\$5.75**

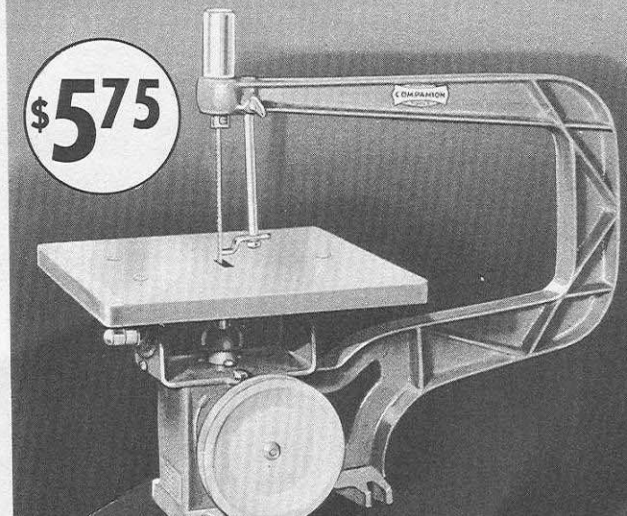

# CRAFTSMAN CONVERTIBLE HEAVY DUTY

REG. U. S. PAT. OFF.

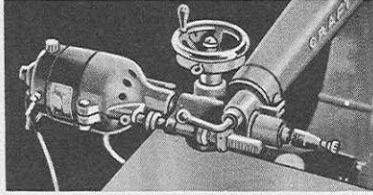

Router head assembly tilted for spindle carving. Scale on head shows angle. Uses cutters below. Does a wide variety of work.

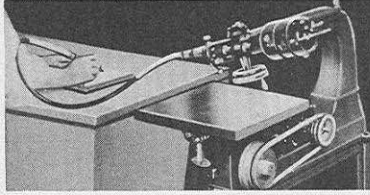

Doing carving with the head in vertical position. Beautiful relief carvings may be produced easily. Pattern guides the work.

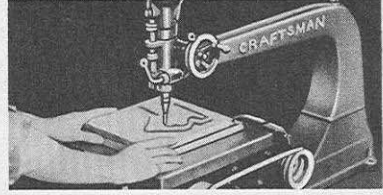

Showing high speed flexible shaft in use with router head for die work. Also used for carving. Shaft driven by the router motor.

## CRAFTSMAN

### High Speed Router Attachment

**\$28.40**

Complete

Price cut 15%. Usual price elsewhere \$34.50. The famous router attachment for the CRAFTSMAN 24-inch jig saw is now offered at a new low price. This attachment is a complete unit in itself—a vertically mounted ball bearing motor which operates at 17,000 R.P.M. and is carried in a rugged housing which encases the steel quill and ball bearing spindle. The motor and quill unit may be raised or lowered by a hand wheel. With this high speed router attachment the home craftsman can do the most intricate sort of routing, carving and grinding, as well as shaping, mortising and tenoning. The high speed flexible shaft can be driven from the router unit. You can add a dovetail jig and router at small cost and do perfect dovetailing. In short, there is scarcely any high speed routing operation which you cannot handle with this router head.

Complete assembly consists of 17,000 R.P.M. 110-120 volt A.C.-D.C. motor, motor bracket with steel quill having milled rack and ball bearing spindle, and set of three collet chucks for 1/8, 1/4 and 3/16-inch shank cutters. It takes the place of regular jig saw head. Fits any CRAFTSMAN 24-inch jig saw, old or new style. Jig saw shown on these pages has a pair of heavy screws, one on each side of arm, that hold the jig saw head in position. When they are loosened the head may be removed and adapter unscrewed. Adapter is then screwed into router and router is put in position in place of head. Shipping weight, 25 pounds.

9 P 2260—High Speed Router, complete.....\$28.40  
99 P 2642—Router Motor only. Shpg. wt., 10 lbs.....\$14.40

For routing and carving bits or other accessories, see Page 27. Use these router bits up through the 3/8-inch size.

## FEATURES

### CRAFTSMAN 24-Inch Jig Saw

- Cuts to center of a 48-inch circle and handles material up to 2 inches thick.
- Extra large table, 14 inches square, made of precision ground heavy gray iron.
- Table mounted on DOUBLE trunnions, front and rear, to secure more rigid support.
- Table tilts to 45 degrees with angle shown.
- Table trunnion equipped with stops at important angular positions.
- Driving mechanism runs in bath of oil, providing positive lubrication.
- Mechanism very perfectly balanced for freedom from vibration.
- Frame scientifically designed for rigidity.
- New design blade guide and thrust—much more convenient and efficient.
- Upper arm removable or may be pivoted.
- Router head attachment available.

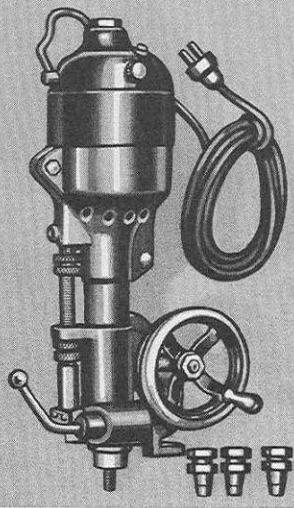

### Machine Files for Jig Saw Use

A special lower jaw (listed on Page 35) can be supplied for using these files on the CRAFTSMAN Jig Saw. Eliminate tedious hand filing. These files have 3/16-inch shanks. Shpg. wt., each, 1 oz.

9 P 2737—3 Square File .55c | 9 P 2738—Round File.....55c | 9 P 2740—Pillar File.....55c  
9 P 2742—Half Round File 55c | 9 P 2739—Crochet File.....55c | 9 P 2741—Square File.....55c

### EASY TERMS!

On Orders of \$20.00 or more see Inside Front Cover



### Carving Cutters for Use With High Speed Router Attachment

9 P 2644—High speed cutters of finest quality tool steel. Specify item wanted. Shipping weight, each, 2 ounces.

Round Nose	Half Round	Liner	3/16-in. Cutter Shank	Button Drill	Hook Tool	Straight Face
\$1.59	\$1.59	\$1.59	45c	\$1.59	\$1.59	\$1.59



### CRAFTSMAN FRET AND JIG SAW BLADES

Catalog Number	Thickness	Width	No. in Pkg.	Type End	Length	Teeth per inch	Use*	Shpg. Wt.	Per Pkg.
9 P 2692	.008 inches	.035 inches	8 blades	Plain	6 inches	22	W. V. Pd	1 oz.	19c
9 P 2693	.010 inches	.045 inches	8 blades	Plain	6 inches	18	W. V. Pd	1 oz.	19c
9 P 2694	.010 inches	.055 inches	8 blades	Plain	6 inches	16	W. V. Pd	1 oz.	19c
9 P 2695	.010 inches	.070 inches	8 blades	Plain	6 inches	14	W. M.	1 oz.	19c
9 P 2703	.020 inches	.070 inches	6 blades	Plain	6 inches	32	M.	1 oz.	19c
9 P 2702	.014 inches	.078 inches	6 blades	Plain	6 inches	16	W. M.	1 oz.	19c
9 P 2709	.020 inches	.110 inches	6 blades	Plain	6 inches	20	G. W. M.	1 oz.	19c
9 P 2710	.020 inches	.110 inches	6 blades	Plain	6 inches	7	W. P.	1 oz.	19c
9 P 2700	.020 inches	.110 inches	6 blades	Plain	6 inches	10	G. W. M.	1 oz.	15c
9 P 2701	.020 inches	.110 inches	6 blades	Plain	6 inches	10	G. W. M.	1 oz.	15c
9 P 2704	.020 inches	.110 inches	6 blades	Pin	5 inches	16	G. W. M.	1 oz.	15c
9 P 2705	.020 inches	.110 inches	6 blades	Pin	5 inches	15	G. W. M.	1 oz.	15c
9 P 2706	.020 inches	.110 inches	6 blades	Plain	3 1/2 inches	10	G. W. M.	1 oz.	19c
9 P 2707	.020 inches	.110 inches	6 blades	Plain	3 1/2 inches	15	G. W. M.	1 oz.	19c
9 P 2708	Assorted		3 blades	Sabre	6 inches	Asst'd	W	1 oz.	19c

\*W—Wood. M—Metal. P—Catalin or other Plastics. V—Veneer. Pd—Plywood. G—General Purpose.



### A Perfect Combination

**\$68.50**

Here's the way to set up your CRAFTSMAN 24-inch jig saw. Get the complete outfit at one time and be fully equipped for any job! The jig saw complete with router head is mounted on a rugged machine stand. A 1/2-H.P. motor is provided to drive the jig saw mechanism. Every part of the combination is described in detail in this catalog. Jig saw and router head are on these 2 pages; motor on Page 43; and the machine stand on Page 40. Outfit includes 99 P 2276 jig saw, 9 P 2260 router, 99 P 5607 motor and 99 P 2745 machine stand. Shipping weight, 191 pounds.

99 P M 2339—Complete Outfit.....\$68.50

# JIG SAW

FULL 24-INCH  
CAPACITY

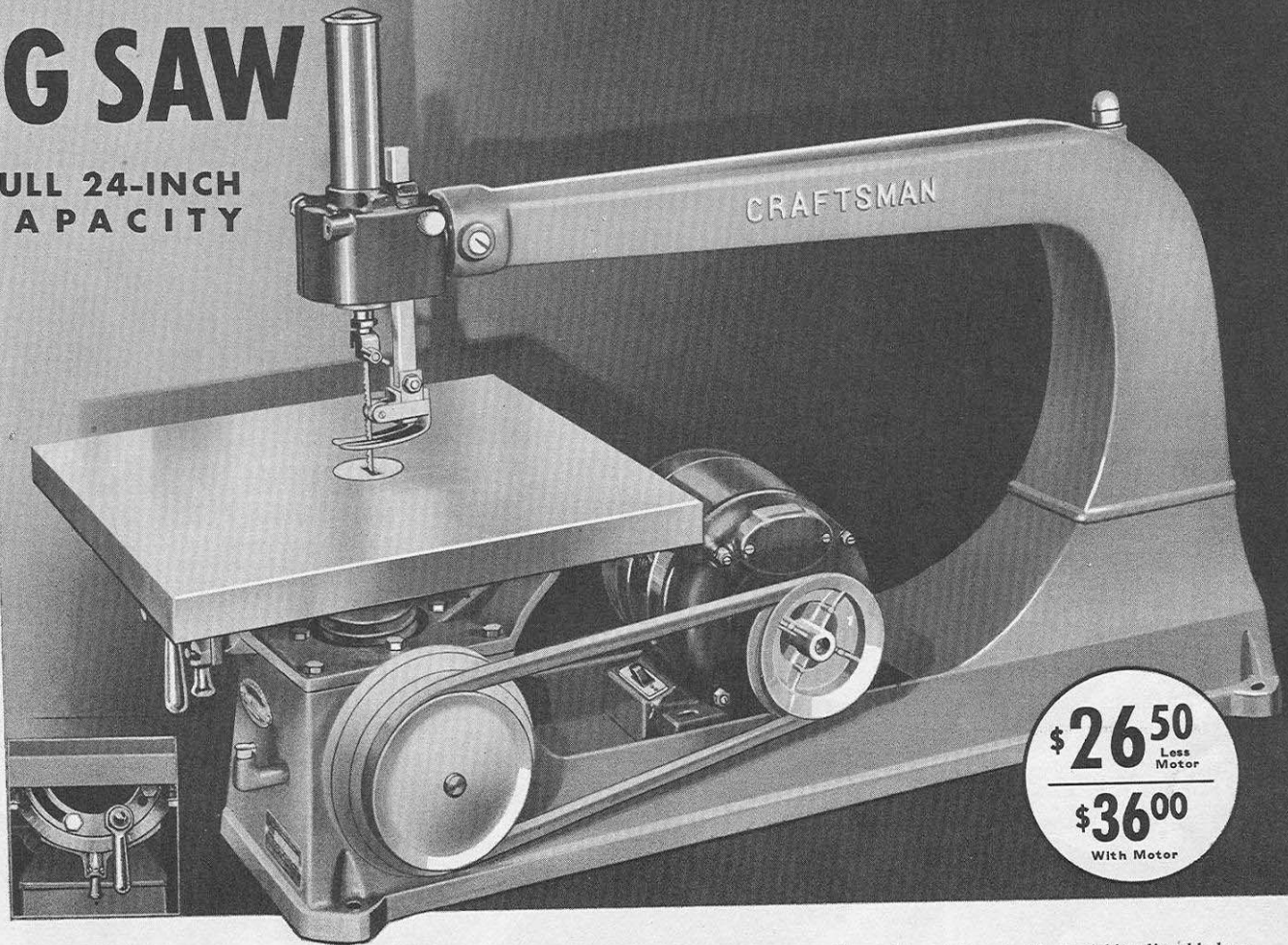

Our engineers and designers co-operated closely with the manufacturers in order to produce the finest jig saw Sears have ever sold. And here it is—a marvel of smoothness in operation; stronger and sturdier in construction; and far more versatile than any jig saw we've ever seen. It has features of other jig saws selling for much more. But even more, it has features you'll find in NO other jig saw on the market!

Note the large table and particularly the way the table is mounted—on two large trunnions for perfect rigidity at all times. Here's a major improvement—important because it is fundamentally right. Note, too, how the motor is mounted in a well in the base so as to keep it down low out of the way. Pivoted motor mount gives smooth, even drive and facilitates changing of speeds for different kinds of work. Works equally well with the smallest fret saw blade or with blades a full 1/4-inch wide.

Can also be used for filing, when equipped with special jaw listed below. Saws non-ferrous metals easily and accurately. Mechanically it is as close to perfection as possible. Give it your hardest jobs! You'll find we haven't told you half the story of its quality and performance! With 4-step drive pulley, 4-step motor pulley and belt.

99 PM 2276—CRAFTSMAN 24-inch Jig Saw without motor. Shipping weight, 105 pounds. . . . . \$26.50

99 PM 2338—CRAFTSMAN 24-inch Jig Saw with 1/3-H.P. ball bearing COMPANION 110-120 volt, 60-cycle A.C. motor. Shipping weight, 135 pounds. . . . . \$36.00

9 P 2332—Special lower jaw to take files shown on opposite page. Shipping weight, 6 ounces. . . . . 79c

**Easy Terms!**  
ON ORDERS OF 100 OR MORE  
—SEE INSIDE FRONT COVER

## SPECIFICATIONS

**SPEEDS:** Operates at 4 speeds—600, 900, 1200 and 1500 for various types of work.

**BASE:** Large rugged gray iron casting with smoothly ground faces. Attractively streamlined. Heavy and rigid in order to reduce vibration to a minimum. Recess in base allows motor to be partially concealed—out of the way where it will not interfere. The crank case is completely enclosed in the front end of the base.

**TABLE:** Made of heavy gray iron, well ribbed, with large 14-inch square working surface. Carefully machined to receive complete set of extensions. Mounted on TWO heavy trunnions. Front trunnion has protractor and plunger type stop for important angles. Tilts to 45 degrees on one side and to 10 degrees on the pulley side. Has 2-inch center soft metal insert.

**ARM:** Large and heavy. 24-inch depth of throat. New scientific design for greatest strength and least vibration. Can easily be swung out of the way or removed entirely. Accurately machined to fit base. Front end fitted for removable vertical guide and pump housing. Has adapter for attaching router.

**CRANK CASE:** A separate self-contained unit. Fitted to table support and, in turn, mounted in base. Large diameter shaft runs in self-oiling bronze bearings. Oversize balanced mechanism runs in oil. Oil pump forces oil to top of crank case and supplies continuous flow to main bearing and upper sections of moving parts. Shaft fitted with 4-step fly wheel pulley for greater smoothness of operation.

**PUMP AND SPRING HOUSING:** Large air pump with hollow vertical saw guide which has key way guide and self-oiling bronze bearings. Oil reservoirs are in direct contact with bronze bearings, supplying lubricant to reciprocating guide shaft. Powerful sawdust blower is built into head. Air is blown in front of saw teeth through hollow guide in chuck jaws, thus eliminating any necessity for tube. Pump tube is adjustable to give any desired tension on saw blades or to take longer blades.

**HOLD-DOWN GUIDE:** Located directly behind blade, or may be shifted 90 degrees for ripping long boards. Has roller guide and is fully adjustable in all directions. Can be mounted under table for saber sawing.

**CHUCKS:** Manganese bronze with removable jaws. Can be fitted with special jaw for filing.

**CANVAS BOOT:** Completely encloses the upper part of the lower guide at all times, preventing abrasive dust from getting into bearings or oil supply.

## Table Extension and Rip Fence

You'll want this handy set for your CRAFTSMAN 24-inch Jig Saw. Accurately made and carefully finished—fit perfectly. The table extensions increase the table size to 18x25 1/2 inches, and allow you to really utilize the large capacity of the tool. They provide a solid surface for work and permit you to handle large jobs with ease. The rip fence is very useful in handling straight work.

Set consists of front extension, 14x4 inches; two side extensions, each 18x5 3/4 inches; and long rip fence, bars and necessary fittings. Front extension is gray iron, ground and finished. Side extensions are steel. Order these accessories with your CRAFTSMAN Jig Saw. They'll give it greater capacity and will make it a far more useful and versatile tool. Shipping weight, 14 pounds.

9 P 2278. . . . . \$7.50



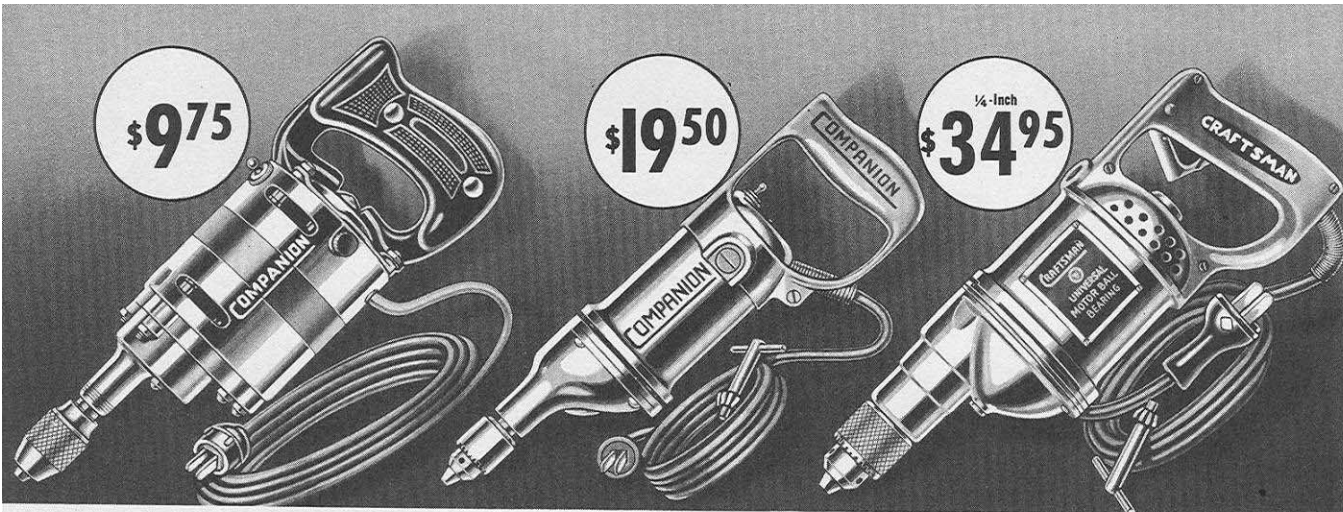

### COMPANION UTILITY DRILL a General Purpose Tool

- Takes drills up to 1/4-inch.
- Ball bearing takes up end thrust.
- Double reduction gears; give extra power.
- Universal motor for 110-120 volt A.C. or D.C.
- Has pistol grip and toggle switch.
- Spindle speed, approximately 1500 R.P.M.

A sturdy, dependable drill for general work around the shop, garage and home. Light—but it packs lots of power! Compact and well balanced, it runs smoothly and efficiently. Well made of quality materials this

**Easy Torque**  
ON ORDERS OF  
120 OR MORE  
SEE INSIDE  
FRONT COVER

COMPANION Drill will give excellent service. This drill represents the most service and satisfaction ever offered anywhere near this price. A fine tool for the home shop. Equipped with 3-jaw chuck, capacity up to 1/4-inch drills. Has well made double reduction gear train. Complete with rubber covered cord and plug. Shpg. wt., 6 lbs. 6 oz.  
9 P 2575.....\$9.75

### COMPANION "PENCIL" DRILL a Close Quarter Tool

- Genuine Jacob's chuck takes straight shank drills up to 1/4-inch.
- Dynamically balanced Westinghouse universal type motor.
- Reducing gears accurately made of finest alloy steel, carefully heat treated.
- High quality ball thrust bearing on chuck spindle sealed in oil.
- No-load speed, 1200 R.P.M.

A high quality lightweight drill with removable handle that permits you to get into the most cramped quarters. Ideal for any job requiring quality combined with light weight. Finely finished, accurately balanced; a handsome tool that you'll be proud to own, one that'll give you years of troublefree service. For use on 110-120 volt A.C. or D.C. Full load wattage of 125. Over-all length, 12 1/2 inches. Complete with handy toggle switch and 8-foot rubber covered cord and plug.  
9 P 2576—Shipping wt., 5 lbs. 1 oz.....\$19.50

### CRAFTSMAN HEAVY DUTY BALL BEARING DRILL

- Equipped with genuine Jacob's chuck.
- Dynamically balanced Westinghouse heavy duty universal motor.
- Both armature and chuck spindles run on oversize ball bearings, sealed in oil.
- Heavy double pole trigger switch.
- Spindles, gears and pinions are chrome nickel steel, precision cut.

Built with plenty of surplus POWER. We guarantee it will not stall when used with maximum size drill specified below. One of the very finest electric drills made anywhere regardless of price. Operates on 110-120 volts A.C. or D.C. Precision ball bearing equipped. Fitted with genuine Jacob's key chuck, and 3-conductor rubber covered cord with plug. Over-all length, 13 1/2 inches.

Catalog No.	Size Drill	No Load Speed	Shpg. Wt.	Price
99 P 2580	1/4-inch	2,000 R.P.M.	10 lbs.	\$34.95
99 P 2581	3/16-inch	1,500 R.P.M.	10 lbs.	37.95
99 P 2582	1/8-inch	1,000 R.P.M.	10 lbs.	39.50



### COMPANION 1/2-Inch DRILL An Outstanding Value

- Equipped with genuine 1/2-inch Jacob's key type chuck.
- General Electric Universal Motor, 110-120 volt A.C. or D.C. No-load spindle speed: 400 R.P.M.
- Heat treated alloy steel gears, pinions, motor shaft and chuck spindle give longer service.

Full 1/2-inch capacity Jacob's chuck—heat treated chrome nickel steel gears and pinions—ball thrust bearing on spindle—the features you want at a price that is remarkably low. Has strong, handsome aluminum alloy housing. Equipped with self-lubricating "oilite" bronze bearings. General Electric motor operates on A.C. or D.C., 110-120 volts. Complete with 1/2-inch Jacob's chuck and key, 10-ft. 3-conductor rubber covered cord and plug. Double pole automatic releasing switch. Length, 16 inches, over all. Shipping weight, 12 pounds.  
99 P 2584.....\$32.50

9 P 2593—1/2-inch Grinding Arbor for use with electric drills. (Do not use with wheels larger than 4 inches.) Shipping weight, 6 ounces.....\$4.50

### CIRCULAR HOLE SAW

Made of finest heat treated high speed steel. Cut clean round holes in wood or metal. Blades and pilot drills easily replaceable. Depth of cut 3/4 in. Use 1/2-in. capacity drill or larger. Complete with mandrel. State size.

Size, in.	3/4	1	1 1/4
Shpg. wt.	3 oz.	9 oz.	14 oz.
9 P 2698	\$2.25	\$2.25	\$2.25
9 P 2697	65c	65c	65c
Size, in.	1 1/2	2	2 1/2
Shpg. wt.	15 oz.	1 lb. 4 oz.	1 lb. 8 oz.
9 P 2698	\$2.25	\$2.45	\$2.90

Saw Blade Only for Circular Hole Saw			
Size, in.	3/4	1	1 1/4
Shpg. wt.	5 oz.	6 oz.	8 oz.
9 P 2697	65c	65c	65c
Size, in.	1 1/2	2	2 1/2
Shpg. wt.	9 oz.	12 oz.	15 oz.
9 P 2697	65c	95c	\$1.35



### CRAFTSMAN Ball Bearing HEAVY DUTY PRODUCTION DRILL

- Equipped with genuine Jacob's key chuck.
- Westinghouse universal ball bearing motor.
- Alloy steel spindle, runs on ball bearings sealed in oil.
- Armature shaft runs on oil sealed ball bearings.
- High torque supplied by heat treated triple reduction gears.
- Heavy double pole switch has continuous action catch.

Built for heaviest production work in auto repair shops, factories and mills. We guarantee it won't stall on any job, when used with largest drill size specified. Fitted with finest heat treated chrome nickel steel triple reduction gears. Fine workmanship and materials assure you years of perfect operation. Operates on 110-120 volt A.C. or D.C. Full load wattage, 510. With Jacob's chuck, key, 10-foot heavy rubber covered 3-conductor cord and plug.

Catalog No.	Size Drill	No Load Speed	Shpg. Wt.	Price
99 P 2585	1/2-inch	750 R.P.M.	25 lbs.	\$48.50
99 P 2586	3/8-inch	525 R.P.M.	26 lbs.	52.95
99 P 2587	3/4-inch	475 R.P.M.	27 lbs.	57.90

# CRAFTSMAN

## MACHINISTS' VISES

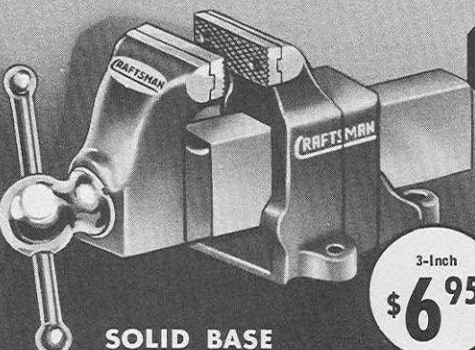

**SOLID BASE**

3-Inch  
**\$6<sup>95</sup>**

ON ORDERS OF  
20 OR MORE  
SEE INSIDE  
FRONT COVER

*Easy Terms!*

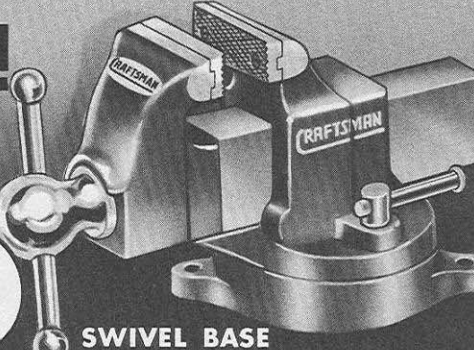

**SWIVEL BASE**

3-Inch  
**\$8<sup>95</sup>**

## GUARANTEED AMERICA'S FINEST QUALITY MACHINIST VISES

Only the finest materials and expert workmanship are used in the manufacture of CRAFTSMAN machinist vises. Built for heaviest machine shop work. Semi-steel construction—strong where strength is needed. Gray enamel finish. Complete with bolts. Shipped freight or express. Shipping weights same as actual weights. 5½-in. jaw size and larger shipped prepaid from factory in Southern Illinois. Smaller sizes carried in stock.

- Replaceable knurled tool steel jaws, heat treated and hardened.
- Extra heavy, extra strong—reinforced at all points of strain.
- Every part carefully machined and fitted.
- Cold rolled steel screw, head and handle.

CRAFTSMAN swivel base vises have all the merit of design found in the solid base type plus the utility of a vise which may be turned to any horizontal position and firmly locked. Gray enamel finish. Complete with bolts. Shipped freight or express. Shipping weight same as actual weights. 5½-inch jaw size and larger shipped prepaid from factory in Southern Illinois. Smaller sizes carried in stock.

Catalog No.	Jaws	Open to	Weight	Price
99 PM 5150	3 inches	4 inches	22 lbs.	\$ 6.95
99 PM 5151	3½ inches	5 inches	31 lbs.	7.90
99 PM 5152	4 inches	6 inches	41 lbs.	8.90
99 PM 5153	4½ inches	6½ inches	59 lbs.	10.85
99 PM 5154	5 inches	7½ inches	78 lbs.	14.00
99 PM 5155	5½ inches	8½ inches	101 lbs.	21.00
99 PM 5156	6 inches	10 inches	130 lbs.	27.30
99 PM 5157	7 inches	12 inches	226 lbs.	38.50
99 PM 5158	8 inches	13½ inches	299 lbs.	52.50

Catalog No.	Jaws	Open to	Weight	Price
99 PM 5160	3 inches	4 inches	27 lbs.	\$ 8.95
99 PM 5161	3½ inches	5 inches	36 lbs.	10.50
99 PM 5162	4 inches	6 inches	51 lbs.	11.90
99 PM 5163	4½ inches	6½ inches	69 lbs.	14.00
99 PM 5164	5 inches	7½ inches	95 lbs.	21.00
99 PM 5165	5½ inches	8½ inches	123 lbs.	26.60
99 PM 5166	6 inches	10 inches	147 lbs.	36.40
99 PM 5167	7 inches	12 inches	254 lbs.	49.00
99 PM 5168	8½ inches	14 inches	345 lbs.	68.60

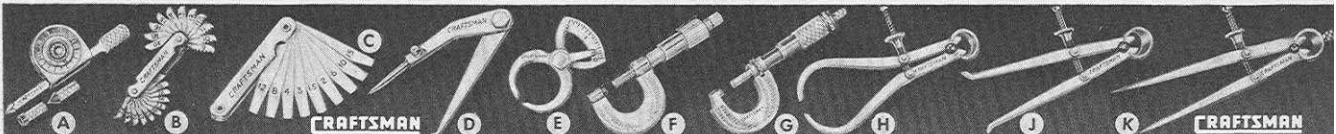

**CRAFTSMAN Speed Indicator**  
 (A) Shows every revolution. Metal handle; 2 rubber tips. Can be set to zero at will.  
 9 P 4060—Shpg. wt., 7 oz. . . . \$1.15

**CRAFTSMAN Screw Pitch Gauge**  
 (B) For determining the pitch of screw threads, either internal or external. Each leaf numbered with its correct pitch. 22 pitches for V-threads, 9 to 40, 1-inch leaves, accurately milled.  
 9 P 4048—Shpg. wt., 2 oz. . . . 98c

**CRAFTSMAN Feeler Gauges**  
 (C) 9 P 4055—9 tapered leaves, .0015 to .015. Makes possible almost any thickness from .0015 to .0615 by half thousandths. Lengths, 3¼ in. Shpg. wt., 1 oz. . . . 75c  
 9 P 4057—25 leaves, .0015 to .025 inch. Makes possible almost any thickness from .0015 to .2755 inch. Length, 2¼ in. Shpg. wt., 4 oz. . . . \$1.98

**Hermaphrodite Calipers**  
 (D) Used for laying out work and locating centers. Tempered, crucible steel legs. Size, 4 inches.  
 9 P 4010—Shpg. wt., 4 oz. 75c

**Indicating Calipers**  
 (E) For measuring thicknesses over shoulders, and otherwise. Lengths and diameters up to 2 inches. Arcs are accurately graduated in 16ths.  
 9 P 4028—Shpg. wt., 4 oz. 95c

**Bargain Micrometer**  
 (F) Very accurate. 0 to 1 inch. Graduated into 1/1000 of an inch. Made in U. S. A. Shipping weight, 6 ounces.  
 9 P 4074. . . . . 89c

**CRAFTSMAN Micrometer**  
 (G) Highest quality! Graduated to read by 1/1000 of an inch. Made in U. S. A. Lock nut and ratchet stop. Decimal equivalents etched on frame.  
 9 P 4069—0 to 1 inch. Shipping weight, 8 ounces . . . . . \$7.75  
 9 P 4071—1 to 2 in. Shpg. wt., 15 oz. \$8.50

**Calipers and Dividers**  
 CRAFTSMAN: Tempered crucible steel legs. Hardened points. Correct shapes. State size. Shpg. wt., 4 in., 4 oz.; 6 in., 6 oz.  
 (H) Outside Calipers. 75c  
 9 P 4019—4 in. . . . . 85c  
 (I) Inside Calipers. 75c  
 9 P 4018—4 in. . . . . 85c  
 (K) Spring Dividers. 85c  
 9 P 4017—4 in. . . . . 75c  
 6 in. . . . . 85c

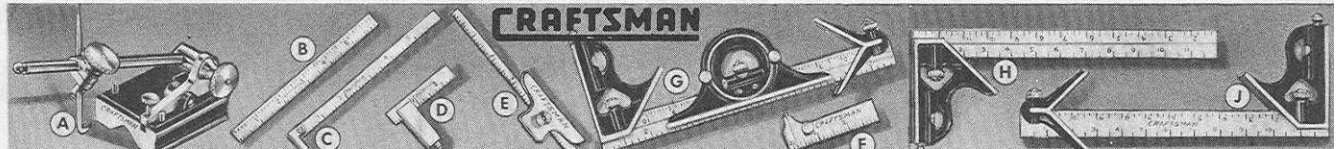

**Surface Gauge**  
 (A) Nine-inch spindle equipped with a 5-in. scriber and a hardened steel base, 2¼ x 1½ x ¾ in. Base front is slotted so spindle can be turned down to allow use of tool as depth gauge. Scriber head has a spring control which holds both scriber and head at any point.  
 Shpg. wt., 1 lb.  
 9 P 4050. . . . . \$2.85

**CRAFTSMAN Steel Rule**  
 (B) Heat-treated crucible steel. Ground, polished satin finish. 6 in. long. Shpg. wt., 2 oz.  
 9 P 4031—Flexible. . . . . 75c  
 9 P 4032—Solid. . . . . 75c

**Narrow Hook Rule**  
 (C) For taking measurements over rounded corners, etc., or for setting dividers or inside calipers. Narrow tempered rule and small hook. Graduated full length.  
 9 P 4035—Shpg. wt., 4 oz. . . . . 98c

**CRAFTSMAN Toolmakers' Square**  
 (D) 2½ x ½ in. sliding blade. Graduated in 32nds and 64ths. A bevel blade and a ½-in. narrow blade interchangeable with graduated blade are included. Shpg. wt., 5 oz.  
 9 P 4041. . . . . \$2.98

**Rule Depth Gauge**  
 (E) Has milled and ground base 3 in. long and narrow tempered 6-in. rule. Head is graduated with lines indicating 30°, 45° and 60°.  
 9 P 4044—Shpg. wt., 5 oz. . . . . \$1.65

**Inside-Outside Caliper**  
 (F) CRAFTSMAN. Graduations etched in 32nds and 64ths. State size. Size . . . . . 3-inch 5-inch Shpg. wt. . . . . 14 oz. 1 lb. 9 P 4021. . . . . \$2.75 \$3.50

**CRAFTSMAN Combination Set**  
 (G) 12-inch hardened steel blade; graduated in 8ths, 16ths, 32nds and 64ths. Center head bevel protractor and square head with level and scratchawl.  
 9 P 4039—Shpg. wt., 1 lb. 14 oz. \$5.25

**DUNLAP Combination Square**  
 (H) With scriber and level. Shpg. wt., ea., 1 lb. State size. . . . . 75c  
 9 P 3954 { 12-in. blade. . . . . 85c

(J) CRAFTSMAN. Same as 9 P 4039, less protractor.  
 9 P 4037—State size. Blade. . . . . 6 in. 12 in. Shpg. wt. . . . . 14 oz. 1 lb. 4 oz. Each. . . . . \$1.98 \$2.85  
 9 P 4036—12-inch. Same as 9 P 4037 less protractor and center head. Shpg. wt., 1 lb. . . . . \$2.35

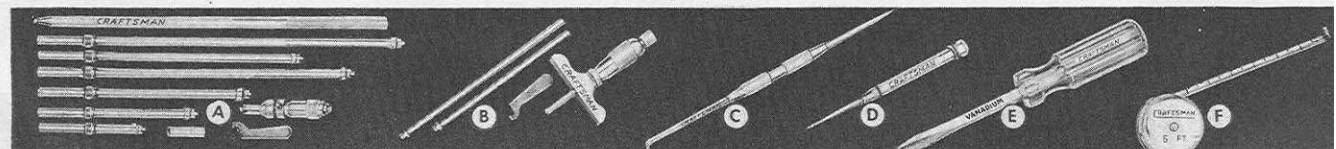

**CRAFTSMAN Inside Micrometer**  
 (A) Range, 2 to 12½ in. by 1/1000 in. Lead screw has ½-in. run. Seven interchangeable measuring rods and two hardened steel collars, ½ and 1 inch in length, which can be slipped over the shank of any rod. Two sets of graduations permit direct readings with or without the collars. Each micrometer is furnished with a long handle for use in places that cannot be reached with the hand. Shipping weight, 1 pound 8 ounces.  
 9 P 4073. . . . . \$7.75

**Micrometer Depth Gauges**  
 (B) CRAFTSMAN. Range 0 to 3 in. by 1/1000 in. Designed to make accurate measurements of the depths of holes, slots, shoulders, projections, etc. Spindle has full 1-in. movement, and is graduated in 1/1000-in. divisions. Three measuring rods with capacity of 0 to 3 in. Base is 2½ in. long and ½ in. wide; hardened, ground, and accurately handlapped at right angles to the rods. Shipping weight, 14 ounces.  
 9 P 4046. . . . . \$8.10

**Double Scribers**  
 (C) Made of fine grade round knurled steel tubing, fitted with a chuck fully tempered, ground, and polished. Points replaceable. Length, 9 in.  
 9 P 4014—Shpg. wt., 4 oz. . . . . 35c

**Pocket Scriber**  
 (D) Body is made of knurled hollow steel tubing, fitted with a chuck which holds the tempered point. Point can be removed and reversed so tool can be carried in pocket.  
 9 P 4012—Shpg. wt., 4 oz. . . . . 29c

**CRAFTSMAN Screwdriver**  
 (E) Transparent amber color handles. Shock-proof! Unbreakable! Strongest made! Tempered chrome-vanadium steel blades, chromium plated. State size.

Size, In.	Shpg. Wt.	9 P 4148
¾x4½	4 oz.	39c
¾x4	5 oz.	49c
¾x6	6 oz.	59c
¾x12	8 oz.	65c
¾x8	10 oz.	79c
¾x12	12 oz.	95c

**Steel Tape**  
 (F) CRAFTSMAN Flex-Rigid Type. No finer made! Bend to fit uneven objects, or may be held rigid like a rule. 6-ft. steel tape is ½-inch wide. Made from tough razor blade steel. Accurate graduations. Nickel plated blade and case. Shipping wt., 4 oz.  
 9 P 3915. . . . . 69c

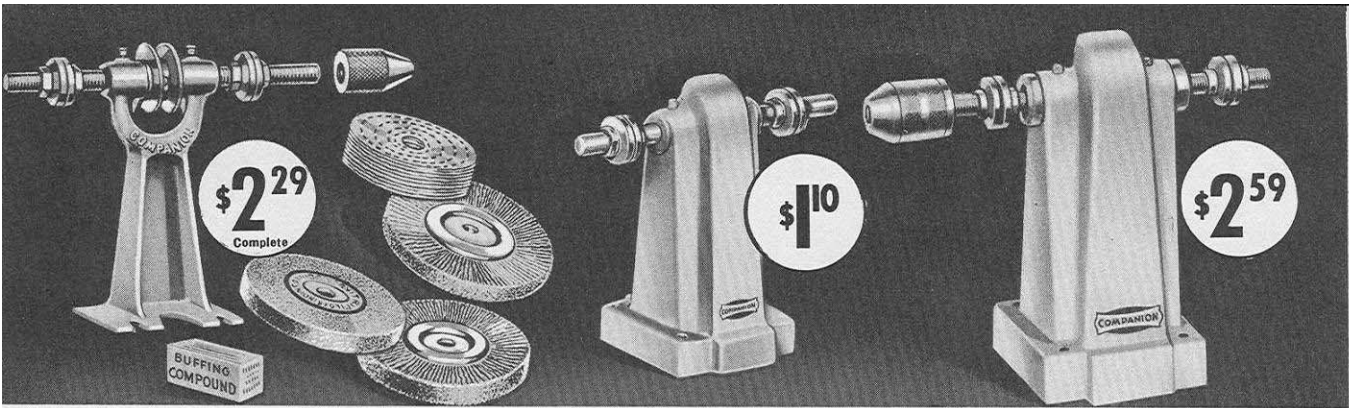

## COMPANION POLISHING SET

Handiest of all small tools for home and shop. With this general purpose 7-piece outfit you can quickly and efficiently sharpen tools, remove rust or paint, grind and polish metals—and may also be used for drilling. The head is 6½ inches high, has 8x½-inch spindle and is equipped with machined steel collars and oil cups. This set includes the polishing head, ¼-inch capacity 3-jaw chuck, 4x½-inch, medium fine vitrified grinding wheel, two 4-inch wire wheels, one coarse and one fine, a 6-inch cloth buffing wheel and cake of buffing compound.

- 9 P 2869—Complete Polishing, Grinding and General Utility Outfit as shown. Shipping weight, 4 lbs. 10 oz. .... \$2.29
- 9 P 2871—Polishing Head only, without chuck and accessories. Shipping weight, 3 lbs. 12 oz. .... 89¢
- 9 P 2130—¼-inch Chuck only. Shpg. wt., 5 oz. .... 29¢

## COMPANION POLISHING HEADS

An exceptionally fine polishing head in the No. 1 size. Equipped with long life **bronze bearings**. Streamlined design covers drive pulley. Rugged gray iron frame. Can be driven from below or behind. 8x½-inch steel spindle. Machined steel collars; 1¾-inch V-type pulley for either ¾ or ½-inch belt. Can be used for grinding, drilling small holes, scraping, buffing and polishing. Accessories needed for above operations, see Pages 25 and 39. Over-all height, 7¼ inches. Blue enameled finish. Shipping weight, 3 pounds 12 ounces.

- 9 P 2874 ..... \$1.10

**Heavy Duty.** Highest quality materials throughout and finest construction—outstanding in performance and design. Furnished with long life **bronze bearings**. Heavy cast iron frame. 9½ x ½-in. steel spindle takes all standard wheels and accessories. Precision built 3-jaw chuck will take drills up to ¾-inch in diameter. Can be driven from below or behind. Carefully machined steel collars. Streamlined hooded frame covers 2-inch V-type pulley. Can be run by either ¾ or ½-inch V belt. Oil cups. Over-all height, 8¾ inches. Blue enamel finish. Shipping weight, 8 lbs. 4 oz.

- 9 P 2875 ..... \$2.59

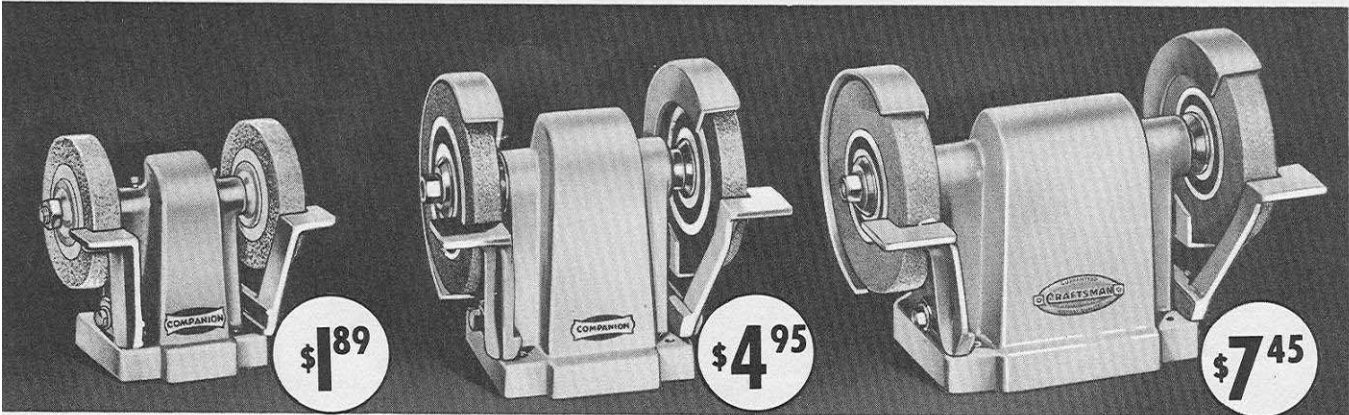

## COMPANION 4-INCH GRINDER

It takes sharp tools to do good work! Keep yours keen edged with this inexpensive two-wheeled 4-inch grinder! Can easily be driven from below or behind. Close grained gray iron frame. Latest streamlined design keeps the drive pulley enclosed for utmost safety. 7x¾-inch steel spindle turned down to ½-inch at ends to fit all standard wheels and accessories. 2-inch diameter V-type pulley for either ¾ or ½-inch V belt. Two 4x¾-inch grinding wheels, one fine grain and the other medium. Pressed steel collars. Oil cups. Tool rests are adjustable front and back. Blue enamel finish. Shipping weight, 6 pounds 2 ounces.

- 9 P 2603 ..... \$1.89

## COMPANION 6-INCH De Luxe GRINDER

This precision built heavy duty bench grinder has the capacity and gives the perfect performance of much higher priced machines. Plenty of clearance to handle large work. Full 6¼ inches between the wheels. Close grained gray iron frame, well-ribbed for added strength. 8½-inch spindle is ¾-inch in diameter, turned down to ½-inch at ends to fit standard wheels and accessories. Heavy, extra-long **bronze bearings**. Adjustable gray iron wheel guards. Equipped with sturdy adjustable tool rests. Streamlined hooded frame covers two-step V drive pulley. Two high quality 6x¾-inch **fully vitrified** grinding wheels, one medium coarse, the other one medium fine. Oil cups. Grinder may easily be driven from below or behind. Attractive blue enamel finish. Shipping weight, 15 pounds.

- 9 P 2618 ..... \$4.95

## CRAFTSMAN Heavy Duty Ball Bearing GRINDER

You can't beat a ball bearing grinder for perfect performance. Highest quality materials and workmanship throughout. Runs with exceptional ease and smoothness on highest quality fully enclosed **ball bearings**, shielded from dust and abrasive particles. Plenty of clearance around the wheels and 9 inches between centers. Perfectly machined 12¼x¾-in. spindle is designed to accommodate the thrust which heavy grinding imposes upon it and is turned down to ½-inch at ends. Streamlined hooded frame. Two-step drive pulley permits adjustment of speed to the material being worked. Sturdy adjustable tool rests. Strong gray iron wheel guards. CRAFTSMAN fully vitrified 6x1-inch grinding wheels, one medium coarse and one medium fine. Carefully machined steel collars insure grinding wheels running straight and true. May be driven from below or behind. Shipping weight, 18 pounds.

- 9 P 2601 ..... \$7.45

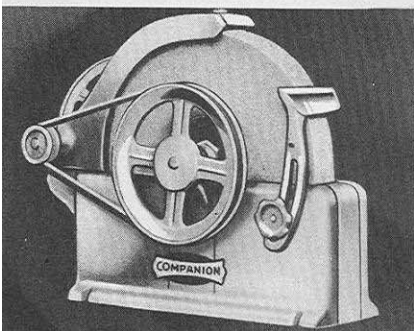

## COMPANION 10-INCH WET GRINDER

Regular Value

~~\$9.50~~

SEARS PRICE  
**\$7.95**

An ideal grinder for the home workshop, farm or factory. Heavy duty cast iron frame. The finest type of grinder to keep your tools in perfect condition. Sharpens all edge tools or knives without danger of drawing the temper. Equipped with highest grade natural grindstone, measuring 10 inches in diameter with 1½-inch face. Perfectly balanced, runs smooth and easy. 3-inch adjustable tool rest. Stone rotates in bath of water so that the surface of the stone is always wet. Handy plug in base to drain water. Equipped with splash guard for your protection. Built-in jack shaft for re-

ducing speed of your motor down to proper grinding speed. Long life **bronze bearings**. Attaches to any bench or table. Attractively finished in gray enamel. Compare competitive prices on a quality grinder of this kind and you will agree that this is a real buy. Make Sears your shopping headquarters and you'll be money ahead. Complete with 6-inch V drive pulley, jack shaft and V belt as illustrated. Shipping weight, 34 pounds.

- 99 P 2620 ..... \$7.95

**Easy Terms!**  
ON ORDERS OF \$10 OR MORE  
SEE INSIDE FRONT COVER

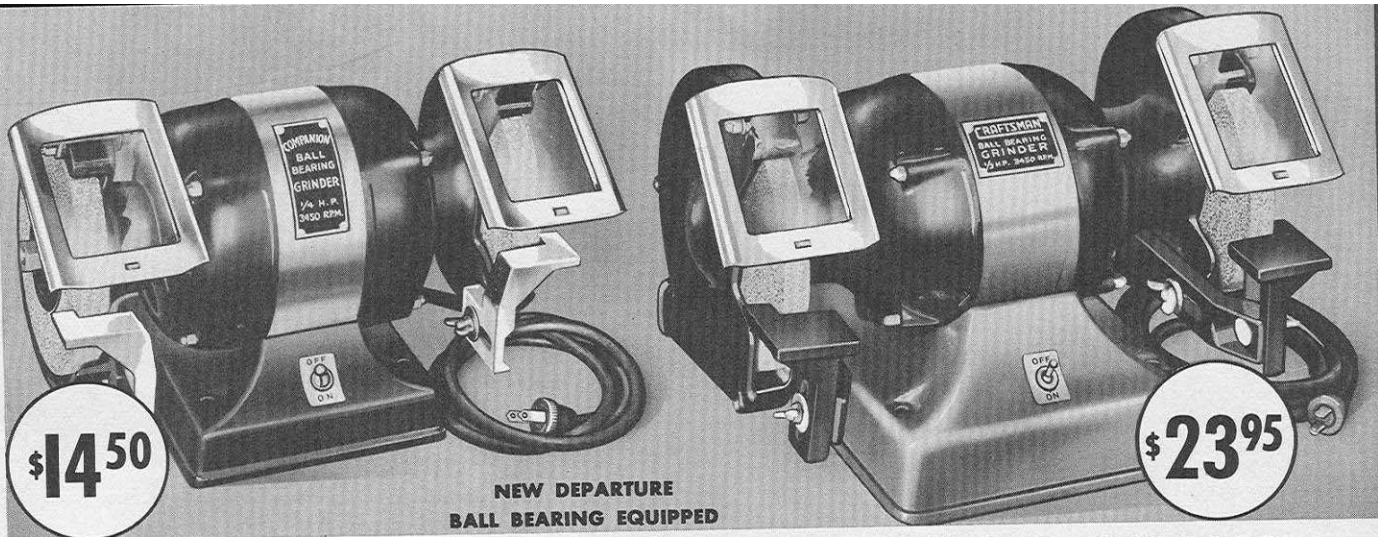

**\$14<sup>50</sup>**

**NEW DEPARTURE  
BALL BEARING EQUIPPED**

**\$23<sup>95</sup>**

**COMPANION 1/4-H. P. GRINDER**

**CRAFTSMAN 1/3-H. P. GRINDER**

A record value! Where but at Sears could you buy a 1/4-H.P. Grinder equipped with New Departure precision ball bearings at this price? Accurately designed, smooth running, high-quality grinder—with plenty of power! Two 6x3/4-inch fully vitrified grinding wheels cut fast and clean. Heavy glass shields with chrome plated frames protect the operator from particles of flying grit. The finely balanced rotor revolves on fully enclosed ball bearings protected from abrasive dust. Large, sturdy wheel collars maintain wheel alignment. Rigid tool rests provide steady surface for work. Tool rests are adjustable for clearance with wheel. The heavily built guards are removable for polishing and buffing operations. Handy built-in toggle switch allows you to start and stop grinder without pulling out the plug. Equipped with soft rubber mountings. Sturdy 1/4-H.P. motor turns 3450 R.P.M. at full load. 3600 R.P.M. no load. For 110-volt 60-cycle A.C. 6-foot rubber covered cord and plug. Shipping weight, 41 lbs.

Extra power! Extra size! Expertly designed, accurately made to give smooth vibration-less action and long life. No shop should be without one. New type soft rubber mountings and new design collars insure freedom from vibration. Ideal for grinding tool bits and most types of general purpose grinding. 13 inches between the wheels. Two 7x3/4-inch, high quality, vitrified grinding wheels—one coarse; one fine. Adjustable glass shields with chrome plated frames. New design keeps motor diameter small so that large work can be held across the front of the machine without striking the motor. Tool rests are adjustable for clearance with wheels. Removable and adjustable wheel guards. Rotor revolves on fully enclosed New Departure ball bearings protected from abrasive dust. Powerful 1/3-H.P. motor. Turns 3450 R.P.M. at full load (3600 R.P.M. at no load). For 110-volt, 60-cycle A.C. Built-in starting switch. 6-ft. rubber covered cord and plug. Shipping weight, 52 pounds.

99 P 2616.....\$14.50

99 P 2617.....\$23.95

**CRAFTSMAN HEAVY DUTY  
1/2-H. P. BENCH GRINDER**

- Heavy duty 1/2-H.P. New Departure ball bearing motor. 3450 R.P.M., full load (3600 R.P.M., no load). Operates on 110-volt 60-cycle A.C. Has built-in toggle switch.
- 7x1-in. vitrified grinding wheels—one coarse; one fine.
- Shatterproof glass shields. Adjustable tool rests.
- Detachable water pan for cooling work.
- Small diameter of motor permits work to be ground across face of machine—more room to operate.

Sears finest! A heavy duty bench grinder that's the biggest value we have ever seen for shops and garages where speed and extra safety are required. Will handle almost any grinding or sharpening job—and do it right! Extra power in the sturdy 1/2-H.P. motor to handle the hard jobs. Carefully balanced grinding wheels insure quiet, efficient operation. Heavy base for stability. Large collars give wheels perfect alignment. New type soft rubber mountings. (For sturdy heavy gauge cabinet for this grinder, see Page 40.) 6-ft. cord and plug. Finest quality and construction throughout! And priced amazingly low! Shipping weight, 60 pounds.

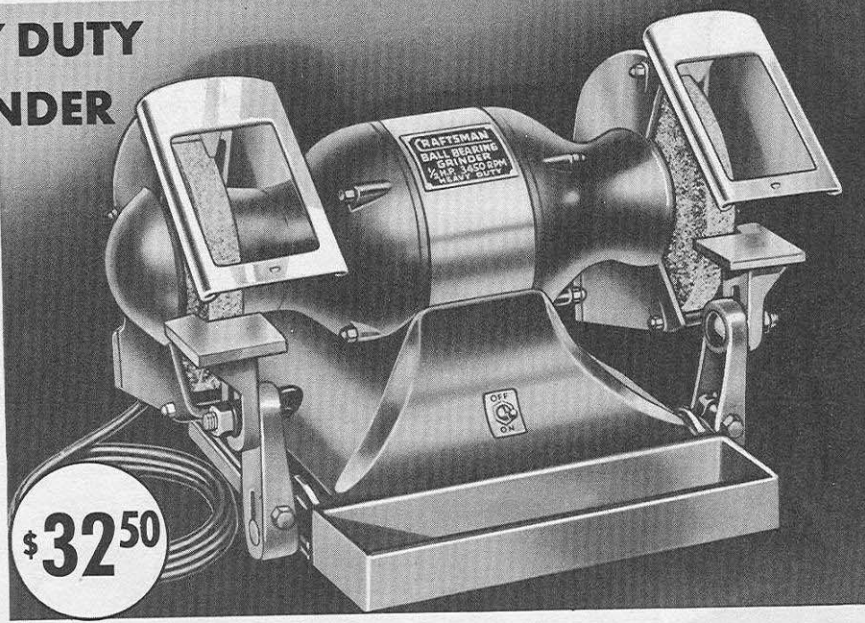

**\$32<sup>50</sup>**

**Easy Terms!**  
ON ORDERS OF 20 OR MORE - SEE INSIDE FRONT COVER

99 P 2609.....\$32.50

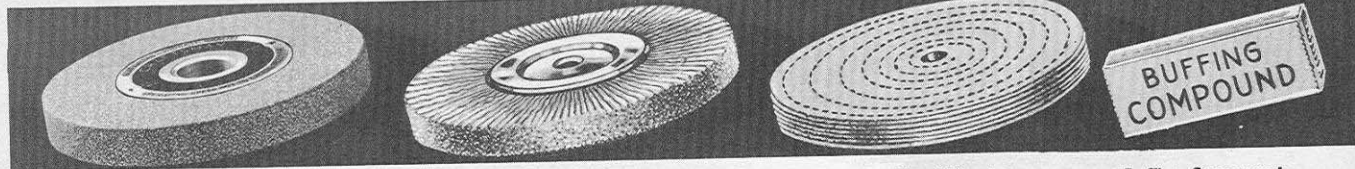

**CRAFTSMAN Grinding Wheels**

Guaranteed America's finest. Fully vitrified. Expertly dressed on both face and sides. Perfectly balanced. Fine grit for fine edged tools. Medium grit for general purpose grinding. Flat face. State diameter, thickness and hole size.

Size	Diameter..... 4-inch	6-inch	7-inch	7-inch
Thickness.....	1/2-inch	3/4-inch	3/4-inch	1-inch
Shipping weight.....	1 lb.	2 lbs. 12 oz.	3 lbs. 10 oz.	4 lbs. 8 oz.
9P6412—Fine Grit.....	49c	\$1.00	\$1.25	\$1.40
9P6411—Medium Grit.....	49c	1.00	1.25	1.40

**Steel Wire Scratch Wheels**

Excellent for cleaning castings, buffing tires, etc. Carefully made, long lasting. 4-inch size has 1/2-inch arbor hole; 6-inch size has 1/2 or 3/4-inch hole. State diameter of wheel and hole size. Shipping weight, 4-inch size, 5 oz.; 6-inch, 11 oz.

9 P 6480—4-inch Coarse.....	35c
9 P 6482—4-inch Fine.....	45c
9 P 6480—6-inch Coarse.....	45c
9 P 6482—6-inch Fine.....	55c

**Buffing Wheels**

First quality material throughout. 20 thicknesses of bleached muslin. 3/8-inch concentric sewing. Expertly trimmed and balanced. 1/2-inch center hole. Specify diameter.

9 P 6490—4-inch. Shipping weight, 2 ounces. Each.....	12c
9 P 6490—6-inch. Shipping weight, 3 ounces. Each.....	15c
9 P 6490—8-inch. Shipping weight, 5 ounces. Each.....	29c



**Buffing Compound**

Used on buffing wheels to produce lustrous satiny finish on metal work. May also be used for polishing catalin and other plastics. Shpg. wt., 5 oz.

9 P 2876..... 15c



**\$9<sup>95</sup>**

## COMPANION WORK BENCH

### Massive . . . Rugged . . . Solid

The most popular work bench we've ever sold. And no wonder—with such quality, such construction at such a remarkably low price! Every piece of lumber is kiln dried, accurately milled and fitted. The top is actually 1½ in. thick. Bench has a handy drawer 20¾x17½ in., 3½ in. deep. A large-capacity woodworking vise, complete with screw, supplied with every bench.

This COMPANION bench is made for *service*. The low price is largely due to our shipping it taken apart—which saves you on freight, too. Easily and quickly put together—following the complete instructions which we include. All you need is hammer and nails.

For power tools—for any woodworking purposes—this bench is ideal! It's big—heavy—sturdy! Top, 26 in. x 6 ft.; height, 32 in.; weight, 134 lbs. Power tools run more smoothly and quietly when mounted on the solid top of this extra strong bench with its sturdy, rigid legs. This bench will do its job through years of hard, steady use.

**Easy Terms**  
ON ORDERS OF \$20 OR MORE  
-SEE INSIDE FRONT COVER

99 PM 2721—Shipping weight, 135 lbs. . . . \$9.95



**\$3<sup>50</sup>**

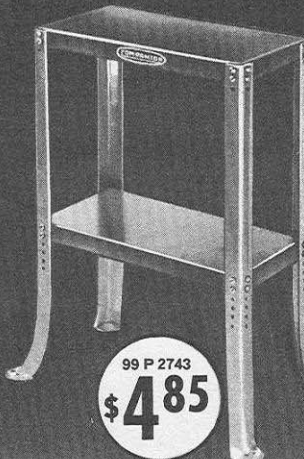

99 P 2743  
**\$4<sup>85</sup>**

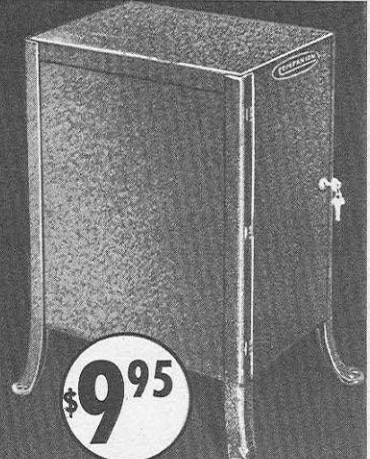

**\$9<sup>95</sup>**

### Wood Machine Stand

A bargain at Sears low price! Thousands of customers, schools, woodworking, cabinet, and pattern shops will take advantage of Sears big value! Extra heavy, rigid wood machine stand, constructed to resist vibration. Selected long grain Douglas Fir. Every piece of lumber is kiln dried, accurately milled, and fitted. Width, 19 inches; length, 25 inches; height, 29 inches. Top is 1½ inches thick. Legs are 2¼ inches square. Apron and shelf are cut from ¾-inch stock. Built-in lower shelf to hold motor or tools. Packed flat for shipping. Very easy to assemble. Holes drilled for bolts at important points. Bolts and nails are provided. Complete instructions furnished for assembling. An exceptional, worthwhile "buy" for the craftsman who wants a good low priced machine stand. Shipping weight, 47 pounds.

99 P 2749 . . . . . \$3.50

### COMPANION Machine Stand

Enjoy neatness in your workshop—smooth, quiet running of your power tools—with these extra heavy, rigid machine stands. Rugged 12-gauge steel. Top and shelf strongly secured to legs. Legs provided with holes for varying height of top or motor shelf. Top and shelf finished in lustrous black; legs in Royal Blue. Packed flat for shipping, very easily assembled.

99 P 2743—Size, top, 10x21 inches. Height, 29 inches. For use with 10-in. and 12-in. band saw. Shpg. wt., 32 lbs. . . . . \$4.85  
99 P 2744—Size, top, 10x21 inches. Height, 31 inches. For use with most other power tools except jig saw on Page 35, jointer on Page 9, and bench saws on Pages 2 and 5. Shpg. wt., 33 lbs. . . . . \$4.85  
99 P 2745—Size, top, 10x34 inches. Height, 31 inches. For 24-inch jig saw, 6-inch jointer, and 99 PM 2176 bench saw on Page 2. Shipping weight, 36 pounds. . . . . \$5.75  
99 P 2746—Size, top, 16x21 inches. Height, 31 inches. For 8-in. bench saw 99 PM 2236 on Page 5. Shpg. wt., 39 lbs. . . . . \$5.65  
99 P 2747—Size, top, 19x25 inches. Height, 29 inches. For bench saw 99 PM 2237 on Page 5. Shpg. wt., 46 lbs. . . . . \$6.50

### COMPANION Machine Cabinet

A roomy, strongly constructed cabinet that's ideal for power tool work. Originally designed as foundation for bench saw 99 PM 2236 on Page 5 and grinder 99 P 2609 on Page 39, but many power tools can be used on it with equal ease and efficiency. There's a large, sturdy shelf inside. Your best tools can be kept in this cabinet in perfect safety. Just the place for precision tools. Equipped with a secure lock and two keys. Top measures 16x21 inches; stands 31 inches high. Solidly braced and rigid throughout. Large rubber pads for feet of stand are provided. Made of extra heavy gauge steel for maximum rigidity and freedom from vibration or noise. Finished in Royal Blue. Note our low price. It's easily a \$15.00 value. Shipping weight, 62 pounds.

99 PM 2718 . . . . . \$9.95

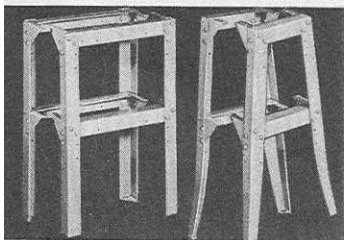

### Steel Work Bench Legs

Build your own work bench. Use these steel legs. Legs have bracket for making lower shelf. Work bench type is used in making a regular width work bench; the lathe type is used for making a lathe bench. Height of work bench type, 32½ in.; width, 20 in. Height of lathe type, 32 in.; width, 10½ in. Set includes two pair. Use 1½ or 2-inch boards for top. Shpg. wt., Set, 37 lbs.  
99 P 2722—Work Bench Legs. . . . . \$3.75  
99 P 2736—Lathe Bench Legs. . . . . \$3.75



### COMPANION Metal Joints

Make your own saw horses, set up tables, platforms, etc. All you need is a set of these rust-proof malleable iron joints, lumber and hammer. No nails required. Joints are provided with lock-tight grippers that prevent sideways, spreading or wobbling. Horses built with COMPANION joints are much stronger.

9 P 2896—Joints for 1x3 lumber, per set of 2. Shpg. wt., 4 lbs. 6 oz. . . . . 85c  
9 P 2897—Joints for 2x4 lumber, per set of 2. Shpg. wt., 10 lbs. . . . . \$1.59



### Workshop Manuals

A valuable set of books—packed with important workshop data . . . replete with photographs and pen and ink illustrations. Metal Lathe Manual has 234 pages. Woodworking books have 72 pages. Shipping weight, set, 2 lbs.; each woodworking book, 7 oz.; Metal Lathe Manual, 1 pound.  
9 P 2919—Set of 4 Woodworking books. . . . . \$1.39  
9 P 2920—The Lathe. . . . . .40  
9 P 2921—The Drill Press. . . . . .40  
9 P 2922—The Band Saw and Jig Saw. . . . .40  
9 P 2923—The Bench Saw, Jointer and Shaper. . . . . .40  
9 P 2925—Metal Lathe Manual. . . . . .95

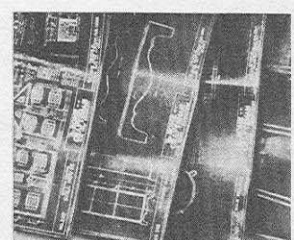

### Easy-to-Use Blueprints

Clear, easy to read. Give all data necessary (materials needed, sketch of finished job, details of joints, directions for finishing, etc.).  
(1) Priscilla Sewing Cabinet, (2) High Back Lawn Chair, (3) Colonial Spinnet Desk, (4) Drop Leaf Table, (5) Garden Trellis, (6) Old West Silhouettes, (7) Work Bench, (8) Hanging Book Rack, (9) Cobbler's Bench Table Lamp, (10) Cedar Lined Chest. State print number wanted. Shpg. wt., each, 3 oz.  
9 P 2900—Each. . . . . 19c



## COMPANION VULCANIZED CORD BELTS

1. Heavy cords at pitch line.
2. Tough cord wrapper.
3. Uniform section accurately molded.
4. Special cushioning insures flexibility.

COMPANION vulcanized cord belts are carefully made—excellent quality throughout—amazingly low in price! They are long wearing, true running, resist slipping and stretching, and transmit power with least friction loss. Heavy duty vulcanized cord wrapper for greater strength. The flexible inner cushion of tough cured

rubber is reinforced at the pitch line by strong cords to insure longer life and greater service. Properly molded, and of uniform cross section, they run true and efficiently. Length shown is distance around outside of belt. Check your outfit before ordering in order to get correct length belt. Use a tape measure.

Easy Terms!  
ON ORDERS OF \$20 OR MORE  
SEE INSIDE FRONT COVER

Catalog No.	Length	Width	Shpg. Wt.	Each	Catalog No.	Length	Width	Shpg. Wt.	Each
9 P 2750	20 inches	3/8 inch	3 ounces	23c	9 P 2762	38 inches	1/2 inch	6 ounces	43c
9 P 2751	24 inches	3/8 inch	3 ounces	27c	9 P 2763	42 inches	1/2 inch	7 ounces	45c
9 P 2752	30 inches	3/8 inch	4 ounces	32c	9 P 2757	45 inches	1/2 inch	7 ounces	49c
9 P 2753	36 inches	3/8 inch	4 ounces	35c	9 P 2764	48 inches	1/2 inch	7 ounces	52c
9 P 2754	42 inches	3/8 inch	4 ounces	42c	9 P 2765	54 inches	1/2 inch	7 ounces	58c
9 P 2755	28 inches	1/2 inch	5 ounces	29c	9 P 2766	58 inches	1/2 inch	8 ounces	63c
9 P 2759	32 inches	1/2 inch	4 ounces	32c	9 P 2767	66 inches	1/2 inch	9 ounces	69c
9 P 2760	34 inches	1/2 inch	6 ounces	38c	9 P 2771	84 inches	1/2 inch	10 ounces	83c
9 P 2761	36 inches	1/2 inch	6 ounces	40c	9 P 2772	100 inches	1/2 inch	12 ounces	95c

## Leather "V" Belting

Here's just the thing for those places where you need a belt of an odd length. Also handy for rapid replacement if you have to remove ball bearings to replace a belt. Cut to any length you want—and have a belt that fits RIGHT—gives you utmost power transmission! Made of tough oak leather—two plies cemented together and strongly sewed down the center. Coupling included with every length. Choice of two widths. State width and length. Shpg. wt., foot, 3 oz.

9 P 2777  
3/8-in. width. Per ft. . . . . 12c  
1/2-in. width. Per ft. . . . . 14c

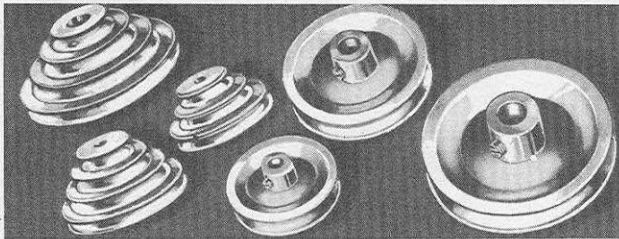

## V Belt Pulleys

A complete line for power tool use—each scientifically designed, carefully and accurately made of finest quality materials. Grooves are machined to be perfectly true. Two set screws in every pulley.

### Scientifically Designed Cone Pulleys

Perfectly balanced at all speeds; will give long, smooth running service. Made of highest quality alloy. Special belt groove construction insures great pulling power and longer belt life. Grooves accommodate 3/8 and 1/2-inch belts. Be sure to state size of bore wanted.

Catalog No.	Size	Steps	Bore, In.	Diam., Step, In.	Shpg. Wt.	Each
9 P 2792	4 in.	4	1/2, 5/8 or 3/4	4, 3 3/4, 2 3/4, 2	1 lb. 10 oz.	55c
9 P 2793	5 in.	5	1/2, 5/8 or 3/4	5, 4, 3, 2	1 lb. 14 oz.	75c
9 P 2798	3 1/2 in.	3	1/2, 5/8 or 3/4	3 3/8, 2 3/4, 2	1 lb.	30c

### High Quality V Belt Pulleys

Made of highest quality alloy, sturdy and long wearing. Strong flanges and hubs with heavy set screws. Finely balanced, true running. Grooves accommodate 3/8 or 1/2-inch wide V belts. Attractively finished in silver aluminum color. Truly better pulleys. Not to be compared with the average variety. Specify size of bore.

Catalog No.	Diam.	Bore	Shpg. Wt.	Each
9 P 2800	1 1/2 in.	1/2 in. only	3 oz.	15c
9 P 2801	2 in.	1/2 or 5/8 inch	5 oz.	19c
9 P 2802	2 1/2 in.	1/2, 5/8 or 3/4 inch	6 oz.	23c
9 P 2803	3 in.	1/2, 5/8 or 3/4 inch	7 oz.	28c
9 P 2804	4 in.	1/2, 5/8 or 3/4 inch	10 oz.	38c
9 P 2805	5 in.	1/2, 5/8 or 3/4 inch	15 oz.	48c
9 P 2806	6 in.	1/2, 5/8 or 3/4 inch	1 lb. 6 oz.	69c

### Heavy Duty Steel V Pulleys

Built expressly for production work. Massive pressed steel construction with steel or malleable iron hubs. Greater rigidity and ruggedness are supplied by the smoothly rolled edges on belt grooves. True running. Strongly welded construction Husky, long lived pulleys constructed of the finest materials. The highest grade production pulleys you can buy! Fit "V" belts 3/8 or 1/2-in. wide. Keyways are provided in all pulleys with 5/8 or 3/4-in. bore. All pulleys have 2 set screws. Be sure to state size of bore wanted.

Catalog No.	Diameter	Bore	Shipping Weight	Each
9 P 2880	1 1/2 in.	1/2 in. only	5 oz.	29c
9 P 2881	2 in.	1/2 or 5/8 inch	6 oz.	35c
9 P 2882	2 1/2 in.	1/2, 5/8 or 3/4 in.	9 oz.	39c
9 P 2883	3 in.	1/2, 5/8 or 3/4 in.	12 oz.	49c
9 P 2884	4 in.	1/2, 5/8 or 3/4 in.	1 lb.	59c
9 P 2885	5 in.	1/2, 5/8 or 3/4 in.	1 lb. 4 oz.	69c
9 P 2886	6 in.	1/2, 5/8 or 3/4 in.	1 lb. 10 oz.	89c
9 P 2808	8 in.	1/2, 5/8 or 3/4 in.	2 lbs. 4 oz.	\$1.19
9 P 2810	10 in.	1/2, 5/8 or 3/4 in.	3 lbs. 12 oz.	1.49
9 P 2812	12 in.	1/2, 5/8 or 3/4 in.	3 lbs. 12 oz.	1.95
9 P 2815	15 1/2 in.	1/2, 5/8 or 3/4 in.	6 lbs. 5 oz.	2.98

### Hollow Head Set Screws

Take place of ordinary set screws on machines. Tremendous pressure exerted by wrench prevents screw from loosening. Nickel alloy steel. Shipping weight, 2 oz.



9 P 2811—1/4 or 3/8-in. State size . . . . . 5c  
9 P 2813—Wrench for above. Shipping weight, 1 ounce. For 1/4 or 3/8-inch screw. State size . . . . . 5c

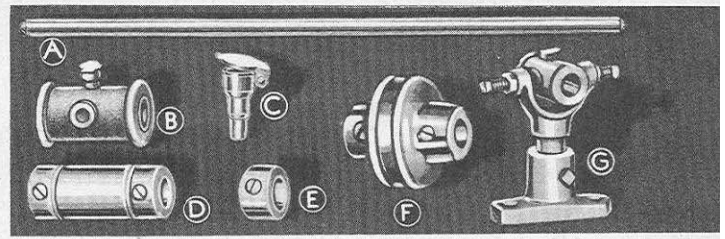

## Line Shaft, Hangers and Accessories

Accurately machined and finely finished parts of high quality. The sturdy hangers have long wearing bronze bushings.

Catalog No.	Description	Shpg. Wt.	Each
(A) 9 P 2833	1/2-in. x 24-in. Steel Shaft	1 lb. 8 oz.	\$0.24
9 P 2834	1/2-in. x 48-in. Steel Shaft	3 lbs.	.48
(B) 9 P 2822	Bronze Bushed Bearing (For 1/2-in. Shaft)	4 oz.	.27
(C) 9 P 2820	Wick Oil Cups	1 oz.	.05
(D) 9 P 2839	1/2-in. Rigid Coupling	5 oz.	.19
(E) 9 P 2824	1/2-in. Line Shaft Collar	2 oz.	.09
(F) 9 P 2840	Flexible Coupling (Specify 1/2, 5/8 or 3/4 in.)	12 oz.	.27
(G) 9 P 2828	1/2-inch Bronze Bushed Shaft Hanger	1 lb.	.95
9 P 2835	3/4-in. x 48 in. Steel Shaft	7 lbs.	.95
9 P 2829	3/4-inch Bronze Bushed Shaft Hanger	1 lb. 12 oz.	1.19
9 P 2825	3/4-in. Line Shaft Collar	4 oz.	.15



## Hard Fiber Pulleys

Highest quality. Made with accurate slips. Faces won't wear smooth, won't slip. The finest made!

9 P 2799—State size and shaft diameter.

Diam. and Face, In.	For Shaft, In.	Shpg. wt., Lbs. Oz.	Each
1 1/2 x 2 1/2	1/2	12	\$1.10
2 x 2	1/2 or 5/8	12	1.19
2 x 2 1/2	3/4	14	1.39
2 1/2 x 2	1	1	1.39
2 1/2 x 2 1/2	5/8 or 3/4	1	1.49
3 x 2 1/2	3/4	1	1.59
3 x 3 1/2	3/4 or 1	2	1.69
3 1/2 x 3 1/2	1	2	1.79
4 x 4 1/2	1 1/4	4	2.15

## Die Cast Pulleys

For use with flat belts. Sturdy and accurately made. Have nearly twice the tensile strength of cast iron. Give excellent service. Fitted with hardened set screws. Accurate bores fit shaft perfectly. Properly crowned so that belts run true and last longer. Carefully balanced to run smoothly without vibration.

9 P 2798—State size and shaft diameter wanted.

Diam. and Face, In.	For Shaft, In.	Shpg. wt., Lbs. Oz.	Each
2 x 2	1/2	1	12
2 1/2 x 2 1/2	5/8 or 3/4	1	13
3 x 3	3/4 or 1	1	18

## HANDY TABLE OF PULLEY SPEEDS

Use this table to determine the speed of your machine with varying sizes of motor and machine pulleys. Figures given are for use with belt at proper tension and a motor speed of 1750 R.P.M.

Diameter of Motor or Driving Pulley	Diameter in Inches of Driven Pulley or Pulley on Machines					
	1 1/2	2	2 1/2	3	4	6 1/2
1 1/2 in.	1725	1290	1030	860	645	520
2 in.	2300	1725	1380	1150	860	690
2 1/2 in.	2890	2160	1725	1440	1080	860
3 in.	3450	2590	2070	1725	1290	1030
4 in.	4600	3450	2760	2300	1725	1380
5 in.	5750	4310	3450	2870	2160	1725
6 1/2 in.	7460	5600	4490	3740	2800	2240

Example—the machine has a 2-inch pulley and should run 3450 or 3500 R.P.M. What size pulley should be used with a 1750 R.P.M. motor? From the table follow down the vertical 2-inch column to the speed 3450, then to the left in column headed "Diameter of Motor or Driving Pulley" read 4-inch diameter required.

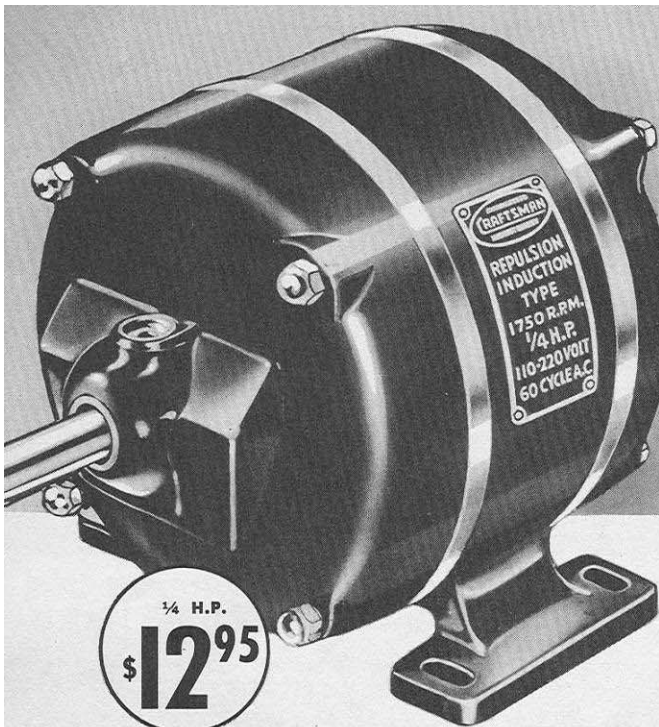

1/4 H.P.  
\$12<sup>95</sup>

- 1 Oversize phosphor bronze bearings insure long service.
- 2 Wool yarn filtered oiling system.
- 3 Long-lived trouble-proof starting device.
- 4 Four large brushes insure high starting torque—for heavy duty.
- 5 Laminations designed to give strong field—cool running.
- 6 Enamelled wire, impregnated and baked.
- 7 Oversize air ducts, keep motor cool.
- 8 Balanced powerful rotor has heavy windings.
- 9 Powerful fan keeps motor cool under load.
- 10 Big oversize frame is unusually sturdy.
- 11 Feet of base slotted for easy mounting.

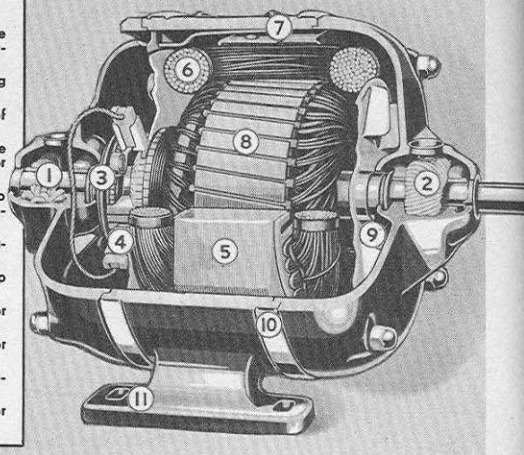

## CRAFTSMAN REPULSION INDUCTION MOTORS

- Guaranteed for 3 years against defects in workmanship and materials.
- Tremendous overload capacity for heavy loads.
- Very high starting effort and extremely low starting current.
- Direction of rotation is easily reversed.
- Very quiet running and highly efficient in operation.
- Meets all A.I.E.E., N.E.M.A., and Central Station requirements.
- Highest quality phosphor bronze bearings for long life.
- Equipped with wool yarn filtered oiling system.
- Will run continuously under full rated load without overheating.

We've tested and compared these CRAFTSMAN Heavy Duty Motors in EVERY way, and believe you will agree they are the strongest, most rugged, longest-lived motors you can buy. Built by manufacturers with a world-wide reputation for quality. They easily start the heaviest loads on cream separators, refrigerators, air compressors, water pumps, etc. Used in large shops and factories all over America for steady production work. Efficient and economical in current consumption. Rotors are in perfect balance, insuring smooth, quiet operation. At full rated load, temperature will not rise more than 40 degrees centigrade. Operating speed, 1750 R.P.M.

Before ordering motors of 1 H.P. or larger, be sure to check with your power company to see if you will require a single phase or three-phase motor, and to make certain your line is heavy enough to carry the motor you want.

### Single Phase—Repulsion Induction

110-220-volt, 60-cycle A.C.

Catalog Number	H. P.	Shpg. Wt., Lbs.	Size, Shaft, Inch	Base Mountings, Inches	Cash Price
99 P 5621	1/4	32	3/8	3 3/4 x 6	\$12.95
99 P 5622	1/2	37	3/8	3 3/4 x 6	17.95
99 PM 5623	1/2	65	3/4	3 3/4 x 7 1/2	23.50
99 PM 5624	1	72	3/4	4 3/4 x 7 1/2	29.95
99 PM 5625	1	79	3/4	5 3/4 x 7 1/2	39.95
99 PM 5626	1 1/2	142	1	6 3/4 x 9	52.50
99 PM 5640	2	155	1	7 1/2 x 9	67.25
99 PM 5641	3	167	1	7 1/2 x 9	85.00
99 PM 5642	5	342	1 1/2	11 x 12 1/2	139.00

### Three Phase—Squirrel Cage Type

220-440-volt, 60-cycle A.C.

Catalog Number	H. P.	Shpg. Wt., Lbs.	Size, Shaft, Inch	Base Mountings, Inches	Cash Price
99 PM 5644	1	84	3/4	9 x 10	\$35.90
99 PM 5645	1 1/2	115	1	10 3/4 x 11	42.00
99 PM 5627	2	130	1	11 x 11 1/2	49.50
99 PM 5628	3	135	1	11 x 11 1/2	55.50
99 PM 5629	5	173	1 1/2	12 1/2 x 13 1/2	69.50
99 PM 5646	7 1/2	278	1 1/2	14 x 15	89.50
99 PM 5647	10	345	1 1/2	16 x 17	110.00

Sizes up to 1 1/2 H. P. shipped from stock, not prepaid. Motors of 2 H.P. or more shipped from New York City, prepaid, except in Seattle or Los Angeles territory where customer pays freight.



1/2 H.P.  
\$27<sup>95</sup>

## CRAFTSMAN HEAVY DUTY BALL BEARING MOTOR

In this motor you get every fine quality of the motors described above and at left plus a double drive shaft and genuine SKF Ball Bearings! This construction permits it to be operated in any position and increases the number of uses to which it may be put. May be used on vertical drives such as drill presses, etc. Sealed ball bearings also make this motor ideal for out-of-the-way installations because these bearings will operate for long periods without attention. Double drive shaft, 3/4-inch diameter, enables you to drive two tools alternately from the same motor. Single phase repulsion induction type, made for 110-220-volt, 60-cycle A.C. 1/2-H.P. 1750 R.P.M. The finest motor you can select for power tools.

99 PM 5619—Shipping weight, 68 pounds.....\$27.95

### Motor Base Adapter

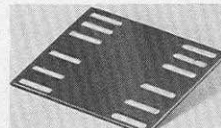

Used for adapting motors to machines not equipped with standard motor mounting. Heavy steel plate with series of slots makes it easy to connect new motor to pumps, washing machines, power tools and other machines with odd size motor mountings. Fits most motors up to 3/4-H.P.

9 P 5593—Shpg. wt., 1 lb. 8 oz. .... 45c

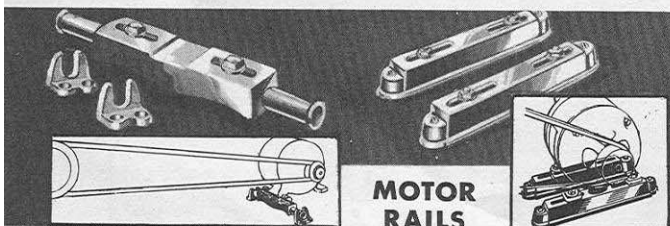

### MOTOR RAILS

**Floating** Makes it possible to drive several different tools using only one motor! Just fasten set of clips near each tool, and shift motor with rail from one tool to another. Keeps belt at proper tension automatically.

9 P 2275—Floating motor rail and one pair clips. Shpg. wt., 1 lb. 13 oz. .... 50c  
9 P 2277—Floating motor rail clips. Shipping wt., 7 oz. Per pair. .... 20c

**Adjustable** Recommended for jobs where motor is to be used on only one tool. To adjust belts merely loosen bolts holding motor to rail, slide motor for belt tension wanted and tighten bolts. Strongly constructed. Shipping weight, 3 pounds.

9 P 2279—Per pair. .... 50c

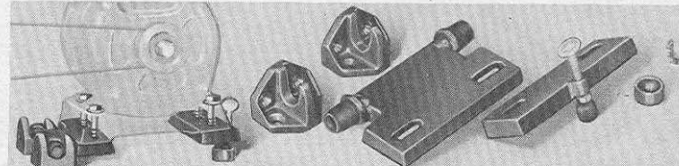

### Deluxe Floating Motor Rail

A new type of floating rail designed for jobs where all vibration must be eliminated in order to do the very finest of work. Designed so that opening of clips is the same as regular floating rail at left so that these rails can be used with old clips. All the advantages of regular type plus rubber cushioning, rear end support, and right angle clips. New type rubber cushioned front rail absorbs all vibration. This rail has rubber collar at both ends of rail. New style right angle clips may be used in normal or right angle position. Rear rail and pivot support may be used to support rear end of motor. Pivot is

equipped with rubber ball that rests in socket. Designed to fit nearly all fractional horse power motors. Shipping wt., 2 lbs.

9 P 2326—Complete Set. .... 90c

9 P 2328—Right Angle Clips. Particularly handy because they may be used at right angles to usual position. In this way they can handle idler drives on drill presses, drives at odd angles, etc. Shipping weight, 10 oz. .... 29c

9 P 2330—Rear Rail and pivot support with socket only. Shpg. wt., 1 lb. .... 29c

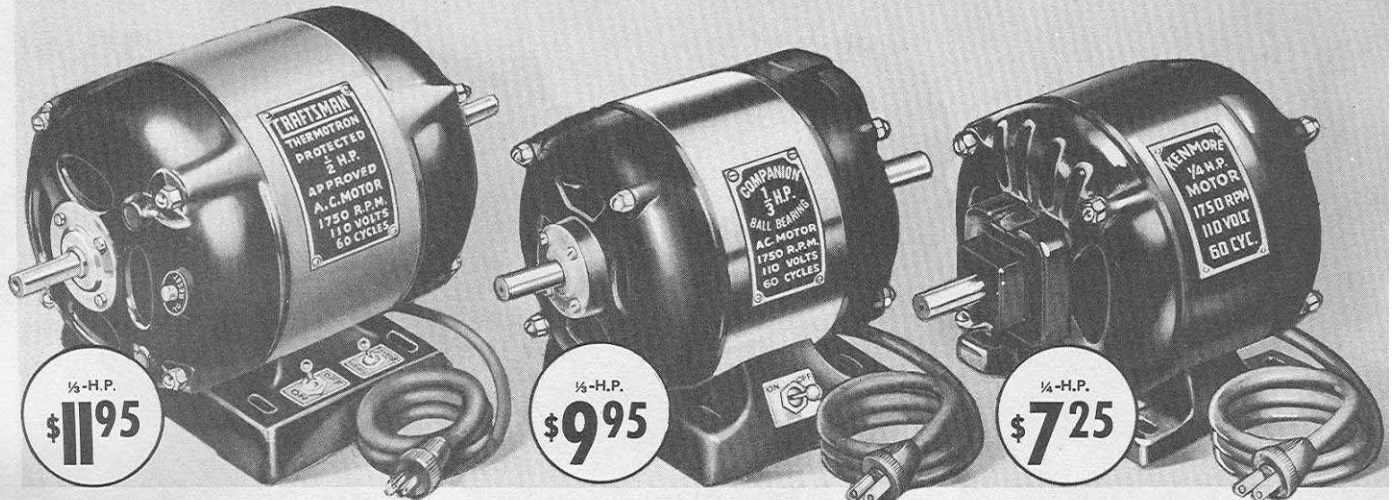

## CRAFTSMAN

### CAPACITOR MOTORS

#### You Can't Burn Them Out

- Guaranteed 3 years against defects in material and workmanship.
- Over-load protector cuts current when windings get too hot.
- Can be reset when motor cools.
- Use much less starting current than ordinary split phase motors.
- Handy built-in reversing toggle switch.
- Built-in start-stop toggle switch.
- Double drive shaft for greater convenience.
- New Departure PRECISION ball bearings.

All the features of motors at right plus positive over-load protection, built-in reversing switch, and built-in condenser in base of motor which greatly reduces current used in starting. Slightly better starting effort than split phase motors. Ideal for power tools and most uses except where large starting effort is required. For 110-120-volt, 60-cycle A.C. Operating speed, 1750 R.P.M. (except 99 P 5587). 1/2-inch drive shaft. Complete with rubber covered cord, and plug.

99 P 5585—1/4-H.P. Shpg. wt., 32 lbs. .... \$11.95  
 99 P 5586—1/2-H.P. Shpg. wt., 35 lbs. .... 14.50  
 99 P 5587—1/2-H.P. For high speed power tools such as jointers, shapers, etc. 3450 R.P.M. Shipping weight, 36 pounds. .... \$16.50

## COMPANION

### SPLIT PHASE MOTORS

#### Our Finest Split Phase Motor

- Guaranteed 2 years against defects in workmanship and materials.
- Runs on grease-sealed New Departure PRECISION ball bearings.
- Handy built-in starting switch.
- Double drive shaft. Easily reversed.

Our finest, sturdiest split phase motor. Every part is extra strong. Heavier windings—larger cooling ducts, frame castings and bearing housings. Fully balanced—built to the highest standards. Heavy over-load capacity to take emergency loads for short periods. Grease sealed New Departure ball bearings require lubrication only after months of operation. Ball bearing construction permits you to use this motor in vertical or any other position. Ball bearings are necessary for motors used with the shaft in a vertical position such as on direct drive drill presses, shapers, etc. Recommended for shop or power tools that don't need the high starting torque of a repulsion-induction motor. Will handle heavy running loads if they are easily started. For 110-120-volt, 60-cycle A.C. 1750 R.P.M. 1/2-inch drive shaft. With switch, rubber covered cord, and plug. Shipping weight, 29 pounds.

99 P 5607—1/4-H.P. .... \$9.95  
 99 P 5583—KENMORE 1/4-H.P. Motor. Same as 99 P 5607 with double shaft and starting switch, but with bronze bearings. Not for vertical drive. 1/2-inch drive shaft. Shpg. wt., 27 lbs. .... \$8.75

## KENMORE

### SPLIT PHASE MOTORS

#### None to Compare at These Prices

- Guaranteed 2 years against defects in workmanship and materials.
- Heavy bronze bearings with wool packing that supplies a constant bath of filtered oil.
- Splashproof end plates.
- Plenty of reserve power.

One of the sturdiest and most reliable 1/4-H.P. motors made! Quiet running... Powerful... Super-insulated. Will carry as heavy a load as any split phase 1/4-H.P. motor on the market. Rotors are accurately and individually balanced to insure quiet, smooth-running performance. New type sealed oil chambers provide trouble-free lubrication. Here's a motor that is lubricated for life at the factory. Unmatched for light shop tools, power tools, etc. At these low prices you can afford to have a motor on each tool for convenience in operation. Heavy steel shaft is reduced to 1/2-inch to accommodate standard accessories. Handles heavy running loads if easily started. Operating speed, 1750 R.P.M. For 110-120-volt, 60-cycle A.C. Rubber covered cord, and plug. Shipping weight, each, 25 pounds.

99 P 5618—1/4-H.P. .... \$7.25

**KENMORE 1/4-H.P. D.C. Motors**

99 P 5615—32-volt. .... \$14.95  
 99 P 5616—110-volt. .... 14.95

Easy Terms!  
 ON ORDERS OF 120 OR MORE—SEE INSIDE FRONT COVER

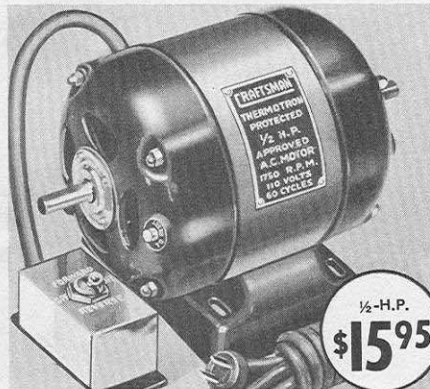

## CRAFTSMAN 1/2 H. P. CAPACITOR MOTOR WITH REMOTE CONTROL SWITCH

Here's a new idea in CRAFTSMAN motors. Particularly handy for power tools but has a wide range of other applications. Motor is controlled by a single heavy start-stop-reverse switch. This switch is mounted in a box and is connected to motor by 30 inches of heavy rubber covered cord. Put your motor out of the way behind or below the machine. Mount the switch at the front of the machine with the rest of your controls—and start, stop, or reverse the motor with a flip of your finger. Far more convenient—and far safer because your control is away from the driving belt and pulley. Shafts are 1/2 inch in diameter.

Aside from remote control switch this motor is exactly the same and has all the features of 99 P 5586 motor shown above. These include built-in condenser, overload protector, double shaft and New Departure ball bearings.

99 P 5584—1/2-H.P. For 110-volt, 60-cycle A.C. Speed, 1750 R.P.M. With 7/16-ft. plug-in cord and 2 1/4-ft. cord on switch. Shpg. wt., 36 lbs. .... \$15.95

### What Type Motor You Should Buy

- To get the most out of a motor, it is important that you select the right type for the job.
- The principal difference in single phase motors is in the way they start. For hard starting jobs like pumps, cream separators, compressors, etc., a repulsion-induction motor must be used. This type will start a load of 3 or 4 times its rated horse power.
- For jobs where the starting effort is not so high, (washing machines, power tools, etc.) you can use either a split phase or capacitor motor. The capacitor motor has the advantage of taking only about half as much current in starting as the split phase type, and starts more easily. This low starting current permits smaller fuses and cuts down any tendency towards flickering of the lights when motor starts.
- On large motors check your power company to make sure that your line is heavy enough to carry the motor you want. If you are in doubt as to which motor to buy, write to Sears Personal Service Department.



## CRAFTSMAN COMPANION REPULSION - INDUCTION HIGH SPEED BALL BEARING MOTORS

These husky high speed motors are packed with power. Guaranteed 3 years against defects in material and workmanship. Fitted with the finest quality SKF ball bearings. Large cooling ducts, frame castings and bearing housings. No matter what horsepower you select, you'll have a thoroughly dependable high speed motor at low cost—giving you plenty of performance in speed, efficiency and economy. Forced draft cooling—lubricate only twice-a-year. Recommended for shapers, bench saws, jointers or other uses where a motor speed of 3450 R.P.M. is wanted. The 1/2-H.P. and 3/4-H.P. sizes have built-in starting switch and rubber covered cord. The 1-H.P. size has circuit breaker, single shaft and heavy rubber covered cord. All are 3450 R.P.M. speed. For 110-volt, 60-cycle A.C.

99 P 5608—1/2-H.P. Shpg. wt., 33 lbs. 1/2-in. double shaft. .... \$19.95  
 99 PM 5611—3/4-H.P. Shpg. wt., 45 lbs. 3/4-in. double shaft. .... 32.50  
 99 PM 5605—1-H.P. Shpg. wt., 62 lbs. 3/4-in. single shaft. .... 46.50

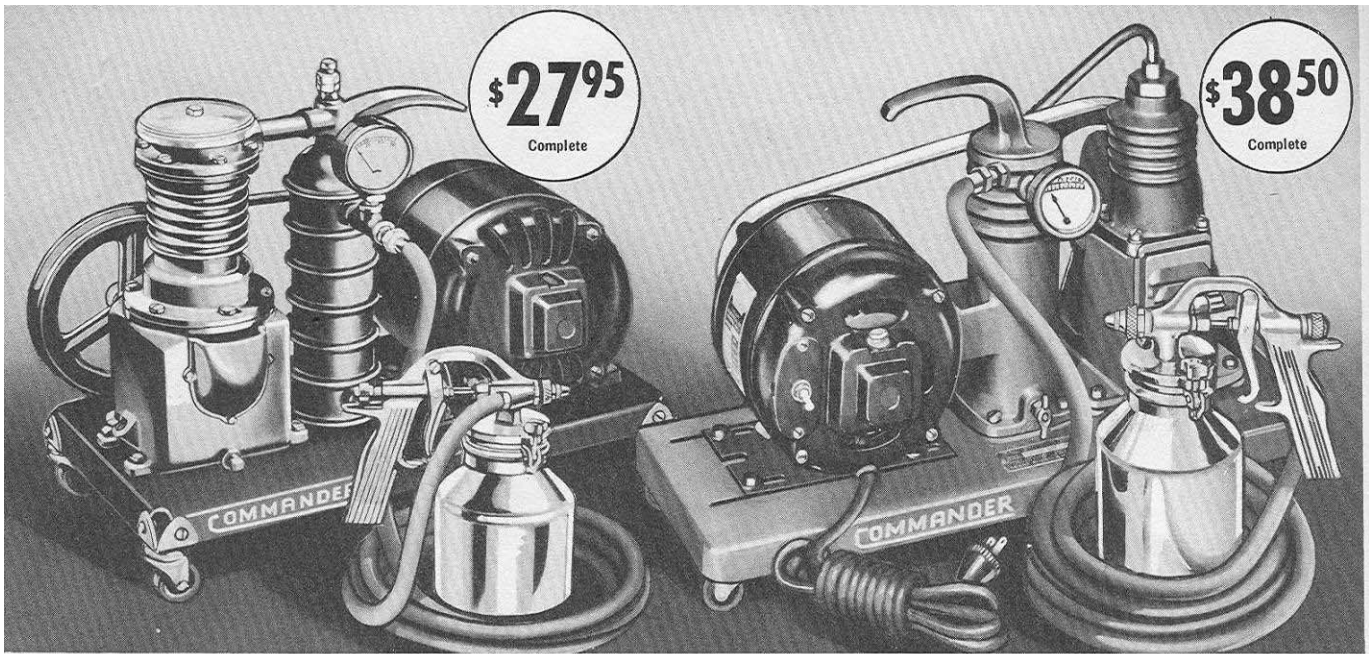

### COMMANDER 1/4-H. P. PAINT SPRAYER

- Finest piston-type compressor for longest life and most satisfactory service. 2 1/2-cubic-foot size.
- 1/4-H.P., 1750 R.P.M. heavy duty motor.
- Piston equipped with two grooves and four rings to keep air absolutely free of oil.
- Mounted on rugged truck—easy to move around.
- Pressure type gun with two nozzles for round or fan spray.

Only at Sears can you buy so fine a piston type sprayer at this price! Compare it with those selling for up to \$50.00! Saves money! Tests have shown it actually works seven times faster than brushing!

Sprays everything—lacquers, enamels, varnishes, disinfectants, insecticides, water colors, dyes, cold water paints and other fluids. Compressor is full 2 1/2-cubic-foot size. Delivers 1 3/4 cubic feet of air per minute at 25 pounds pressure. Maximum pressure about 45 pounds per square inch. Normal working pressure, about 25 pounds. Internal mix pressure feed spray gun. Gun is bleeder type, allowing a continuous flow of air through nozzle, thus preventing paint from clogging nozzle. Complete with motor, compressor, air chamber, pressure type gun with two tips and two air caps, 1-quart aluminum paint cup, 15 feet of 1/4-inch high pressure hose, V belt drive, castor mounted steel base, air gauge, safety valve, cord and plug. Base is 8x16 inches. Height, about 13 1/2 inches. Operates on 110-120 volt 60 cycle A.C.

99 PM 5631—Complete with motor. Shpg. wt., 57 lbs. . . . . \$27.95  
 99 PM 5575—Complete outfit, without motor.  
 Shipping weight, 28 pounds . . . . . 21.50

*Easy Terms!* ON ORDERS OF \$20 OR MORE SEE INSIDE FRONT COVER

### COMMANDER 1/3-H. P. PAINT SPRAYER

- Finest piston-type compressor for longest life and most satisfactory service. 3 1/2-cubic-foot capacity.
- 1/3-H.P., 1750 R.P.M. motor equipped with starting switch.
- Heavy duty wick-oiled compressor supplies clean air—absolutely free of oil.
- Mounted on rugged truck—easy to move around.
- Pressure type gun with two nozzles for round or fan spray.

Bigger! Heavier! More powerful! And with extra capacity! Compare it with sprayers selling for up to \$65.00! Will actually pay for itself within a few years in the time and labor it saves.

Made to give years and years of satisfactory service. Sprays everything—lacquers, enamels, varnishes, disinfectants, insecticides, water colors, dyes, cold water paints and other fluids. Full 3 1/2-cubic foot compressor. Oilless bronze crankshaft bearings and cast bronze connecting rod. Fan type flywheel circulates air around compressor to keep it cool. Mounted as a unit on a heavy steel base. Equipped with casters. Maximum pressure, about 50 pounds per square inch. Normal working pressure, about 25 to 30 pounds. Gun is internal mix bleeder type, allowing a continuous flow of air through the nozzle. Motor is full 1/3-H.P.; has toggle switch for starting. Outfit includes motor, compressor, air chamber, gun complete with 1-quart aluminum paint cup, 1/4-in. high pressure hose, V-belt drive, castor-mounted base, air gauge, safety valve, starting switch on motor, cord and plug. Base, 7 1/2 x 20 inches; height over all, 13 1/2 inches. Operates on 110-120 volt, 60-cycle A.C.

99 PM 5576—Complete as illustrated. Shpg. wt., 68 lbs. . . . . \$38.50



### COMMANDER DELUXE 1/3-H. P. SPRAYER

All the features—all the fine quality—all the smooth, efficient operation of the COMMANDER 1/3-H.P. paint sprayer described above at right! But even more, this sprayer is built with the motor, compressor and other parts mounted conveniently on an oversize pressure tank, 10 inches in diameter and 18 inches long. This means more efficient operation because pressure tank absorbs slight pulsations from compressor and gives a very even pressure.

Finest, heavy duty, wick-oiled type compressor always supplies clean air—absolutely free of oil. The large tank is made of heavy gauge steel. Its large size means a large reservoir of air in reserve to insure smoother operation of gun in spraying than is usually possible. Safety valve prevents pressure becoming too high; gauge indicates pressure at all times. Includes 1/3-H.P. 1750 R.P.M. motor, compressor, oversize tank, 1-quart aluminum paint cup, pressure-type gun with two tips and two air caps, 15 feet of 1/4-inch high pressure hose, V-belt drive, pressure gauge, pressure relief valve, starting switch on motor, cord and plug. Operates on 110-120 volt, 60-cycle A.C. Shipping weight, 75 pounds.

99 PM 5577—Complete as illustrated. . . . . \$44.50

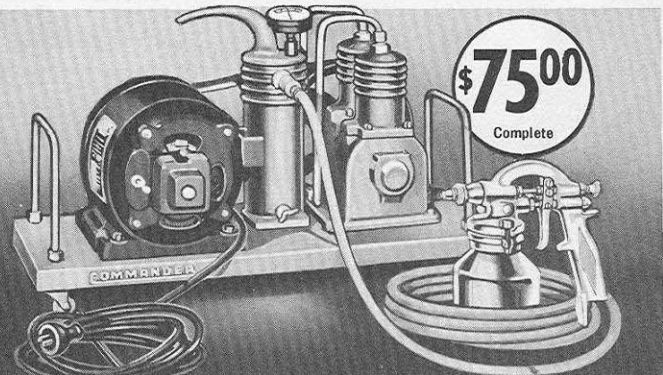

### COMMANDER 1/2-H. P. SPRAYER

By far our finest sprayer—and no wonder! Has extra quality—extra strength—and extra capacity! The powerful twin-cylinder, air cooled piston compressor has 5 cu. ft. capacity. The new heavy-duty, non-bleeder, production type gun with dual valve construction will work three times as fast as ordinary guns and give better results. Enables you to use the full capacity of the big twin cylinder compressor to its best advantage. Complete with 1/2-H.P. condenser type motor, twin cylinder compressor, production type gun, castor base, 1/4-in. two-ply high-pressure hose, 1-quart aluminum paint cup, two tips, two air caps, V-belt drive, pressure gauge, pressure relief valve, starting switch on motor, cord and plug. Rated displacement of compressor is 5 cubic feet per minute. Operates on 110-120 volt, 60-cycle A.C. Shpg. wt., 125 lbs.

99 PM 5597—Complete as illustrated. . . . . \$75.00

COMMANDER Gasoline Powered Sprayer. Similar to above sprayer, but gasoline type gun. The air-cooled Briggs & Stratton motor is the finest money can buy. Easily started by stepping on foot pedal—no kick-back.

99 PM 5598—Complete. Shpg. wt., 145 lbs. . . . . \$97.50

**\$26<sup>50</sup>**  
Cash  
Complete

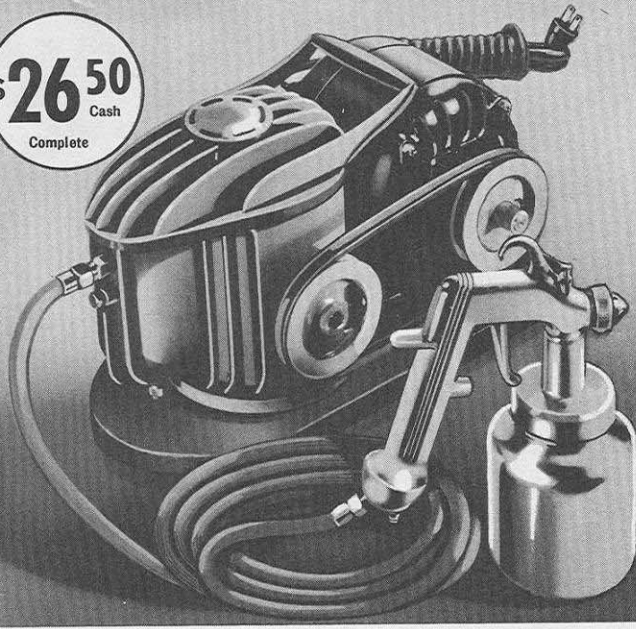

**\$61<sup>50</sup>**  
Cash  
Complete

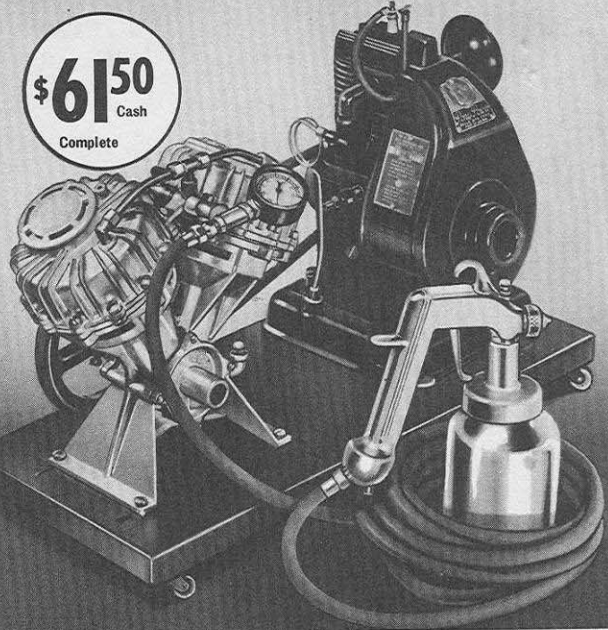

## NEW "KLEEN-AIR" SPRAYER

- **NEW! STREAMLINED BEAUTY!** Sears exclusive design ball bearing compressor gives maximum power and efficiency. Greatest improvement in years—both compressor and motor bearings are permanently sealed in oil at the factory—NEVER NEED TO BE OILED AGAIN. Guarantees oil-free air. Inflates auto tires. Can be used as a vacuum pump.
- **Newest Diaphragm Compressor.** Diaphragms last for years for home use—many months in daily production work, are replaced in 3 minutes and sprayer is good as new. No other working parts to wear out.
- **Compressor guaranteed to furnish 2½ cubic feet of free air per minute and a working pressure over 30 pounds per square inch.**
- **Three-point floating mounting—for quiet operation.**
- **Adjustable, new "filter-in-handle" Kleen Air pressure-type gun.**

Sprays anything from house paint to lacquer up to 1200 square feet per hour. Outfits costing twice as much do no more. Equipped with air chamber, intake filter, safety valve and carrying handle, mounted on 8x15-inch steel base. Heavy duty ¼-H.P. motor with toggle starting switch, 10-ft. cord and plug, V-belt drive. Equipped with 15 ft. of high grade ½-in. air hose. Operates from belt line, gasoline engine or any 1750 R.P.M., ½-inch shaft motor. Complete outfit sold on Easy Terms, \$3.00 down. See inside front cover.

- 30 P 3233—Complete with ¼-H.P., 110-120 volt, 60-cycle A.C. 1750 R.P.M. heavy duty motor. Shpg. wt., 48 lbs. Cash.....\$26.50  
 30 P 3232—Outfit less motor. Shpg. wt., 22 lbs..... 19.50  
 30 P 3231—Outfit less motor, hose and gun. Shpg. wt., 19 lbs..... 12.95  
 30 P 3239—Extra diaphragm. Shipping weight, 2 ounces..... 25c

ON ORDERS OF \$20 OR MORE  
**Easy Terms!** SEE INSIDE FRONT COVER

## V-TYPE TWIN "KLEEN-AIR"

- **New V-Type Twin does any size job.** Has twice the capacity of streamlined "Kleen-Air," at left and will spray 75% to 100% faster. Developed especially for big work.
- **Double Diaphragm Compressor Unit.** Actually furnishes by test over 5 cubic feet of "oil-free air" per minute and a working pressure of over 40 pounds.
- **Double Capacity.** Sprays any coating; from thinnest lacquer to regular house paint as it comes in the can up to 2000 square feet per hour. Inflates tires, can be used as vacuum pump.
- **Equals sprayers selling for twice this price by others.**
- **Furnished with exclusive design "Kleen-Air" spray gun with moisture filter in the handle of the gun where it is most efficient.** Furnishes absolutely clean air—free from oil or water.

Outfit consists of double diaphragm compressor (V-Type unit) mounted on 11x28-inch reinforced steel base, equipped with sturdy steel casters, "V" belt and pulley, powerful ¾-H.P. air cooled gasoline engine, (or heavy duty ½-H.P. R.I. electric motor), genuine "Kleen-Air" spray gun, air gauge and 15 feet of high grade ½-inch air hose. Sold on Easy Terms. See inside front cover. Electric motor equipped with 10-ft. cord and plug.

- 30 PM 3247—Outfit as shown with ¾-H.P. gasoline engine complete. Shipping weight, 88 pounds. Cash.....\$61.50  
 30 PM 3246—Outfit with ½-H.P. heavy duty R.I. motor, 1750 R.P.M., 110-120 volt, 60-cycle A.C. complete. Shipping weight, 111 pounds. Cash. \$55.00  
 30 P 3245—Outfit with 15-ft. hose and gun, less motor or engine. Shipping weight, 45 pounds. Cash.....\$29.95  
 30 P 3279—Extra diaphragm. Shipping weight, 3 ounces..... 25c

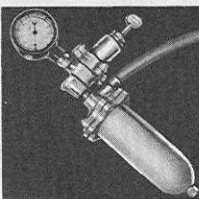

### Gauge

Graduated to register accurately the air pressure available for the spray gun. Shipping weight, 8 ounces.  
 9 P 5649.....69c



## INDUSTRIAL SPRAY OUTFIT

Constructed especially for service stations, garages, factories, and other establishments having pressure air systems. Very useful, sprays everything!

**\$1195**  
Complete

Complete as shown with gun, 15-ft. hose, filter, gauge and reducing valve for regulating pressure to less than 50 lbs., and shut-off valve. Shpg. wt., 15 lbs.  
 9 P 5633—Complete as illustrated.....\$11.95

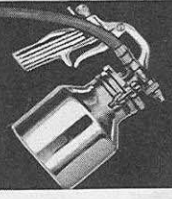

### Air Hose

High pressure type. Made to give long, hard service. Complete with fittings. Two or more lengths may be coupled together. Couple an extra length onto your gun hose. Lgth., 15 ft.; inside diameter, ¼ in. Shpg. wt., 11b. 8oz.  
 9 P 5638.....\$1.39

### Material Hose

Heavy two-ply construction for long life and service. Length, 12½ feet; ¾-inch inside diameter. Two or more lengths of hose may be coupled together. Complete with all the necessary fittings. Shipping wt., 2 lbs.  
 9 P 5639.....\$2.50

### Reducing Valve and Filter

Valve reduces and controls air pressure to below 50 pounds so it can be used by gun. Filter prevents oil, water and other impurities from getting into the air stream. Complete with shut-off. Shpg. wt., 6 lbs.  
 9 P 5648.....\$3.35

### SERO-WAY SPRAY GUN



A very efficient gun of the smaller type. Operates very satisfactorily on ¾ to 2 cubic feet of free air per minute.

It's equipped with 2 brass nozzles, one of which produces a round and the other a flat spray. Lightweight, easy to clean. Gives first class results on any spray job. Shipping weight, 3 pounds.  
 30 P 3285.....\$2.98

### ALL PURPOSE SPRAY GUN



Bleeder-type pressure gun. This type provides continuous air flow through nozzle—keeps nozzle clean. Trigger controls paint flow. This type is best for intermittent service. Complete with 2 nozzles and 2 air tips. Aluminum paint cup holds 1 quart. Easy action; nicely balanced. Shipping weight, 3 lbs. 12 oz.  
 9 P 5637.....\$6.50

### HEAVY DUTY SPRAY GUN



Production-type gun with 2 valves that control both material and air from trigger. Non-bleeder type. Material valve is adjustable. Operates on 3 to 5 cubic feet of air. Two inner fluid tips and two spray caps. Finest construction throughout. Shipping weight, 5 pounds.  
 9 P 5594.....\$10.95

### MATERIAL TANK

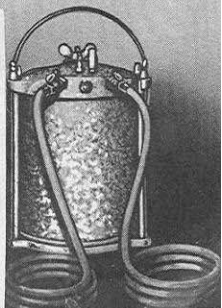

COMMANDER 2-gallon pressure feed tank. Handy for painting large surfaces; it eliminates the need for a paint cup and the necessity of frequently filling it. Complete with 15-foot air hose and 12½-foot material hose. Shipping weight, 25 pounds.  
 99P5632\$9.90

# CRAFTSMAN

REG. U. S. PAT. OFF.



# COMPANION

REG. U. S. PAT. OFF.

THE NATION'S CHOICE IN QUALITY POWER TOOLS  
COMPARE THESE TOOLS WITH THOSE SELLING  
FOR \$20<sup>00</sup> TO \$25<sup>00</sup> ELSEWHERE



99 PM 2019—CRAFTSMAN Lathe. 9-in. swing; 30-in. centers; 44-in. bed. See page 16.

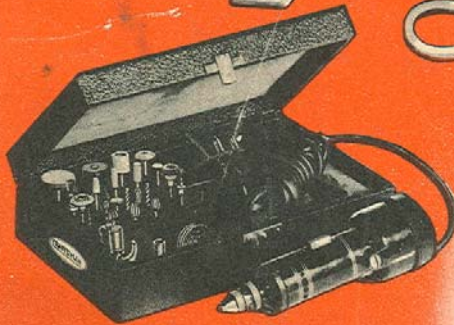

9 P 2651—CRAFTSMAN Rotary Electric Tool complete with accessories. See page 31.

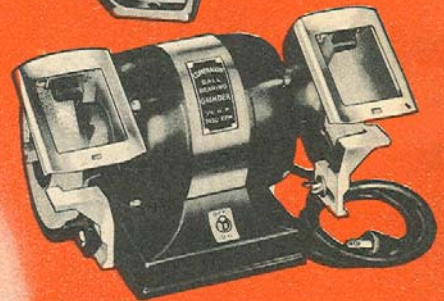

99 P 2616—COMPANION 1/4-H. P. Ball Bearing Grinder. See page 39.

YOUR CHOICE  
**\$1450**  
EACH  
ANY TOOL ON  
THIS PAGE

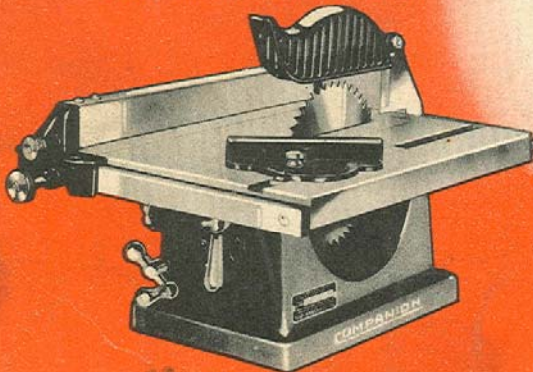

99 PM 2171—COMPANION 7-Inch Bench Saw. Table size, 12 1/4 x 16 1/16 in. See page 1.

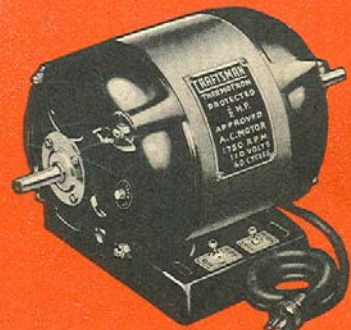

99 P 5586—CRAFTSMAN 1/2-H. P. Capacitor Motor. 1750 R. P. M. See page 43.

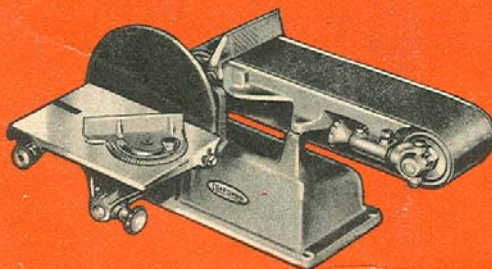

99 PM 2213—CRAFTSMAN Combination 4-in. Belt and 8-in. Disc Sander. See page 32.

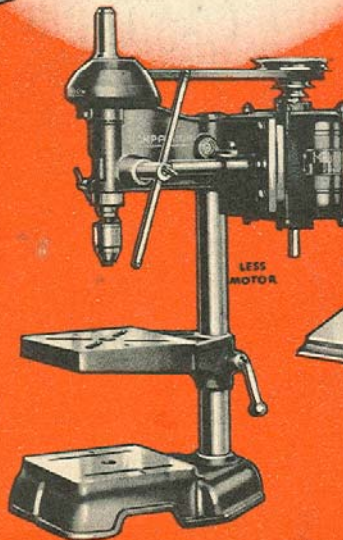

99 PM 2378—COMPANION Drill Press. 1/2-inch capacity. See page 25.

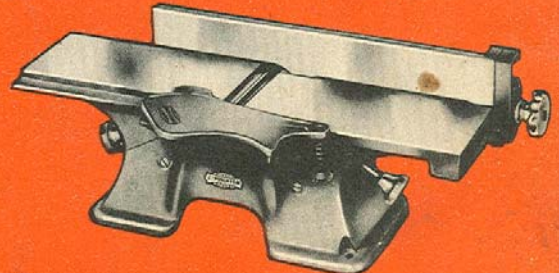

99 PM 2287—COMPANION 4 1/4-Inch Jointer Planer. See page 8.

# SEARS, ROEBUCK AND CO.