

A COMPLETE LINE OF

CRAFTSMAN
REG. U. S. PAT. OFF.

POWER TOOLS

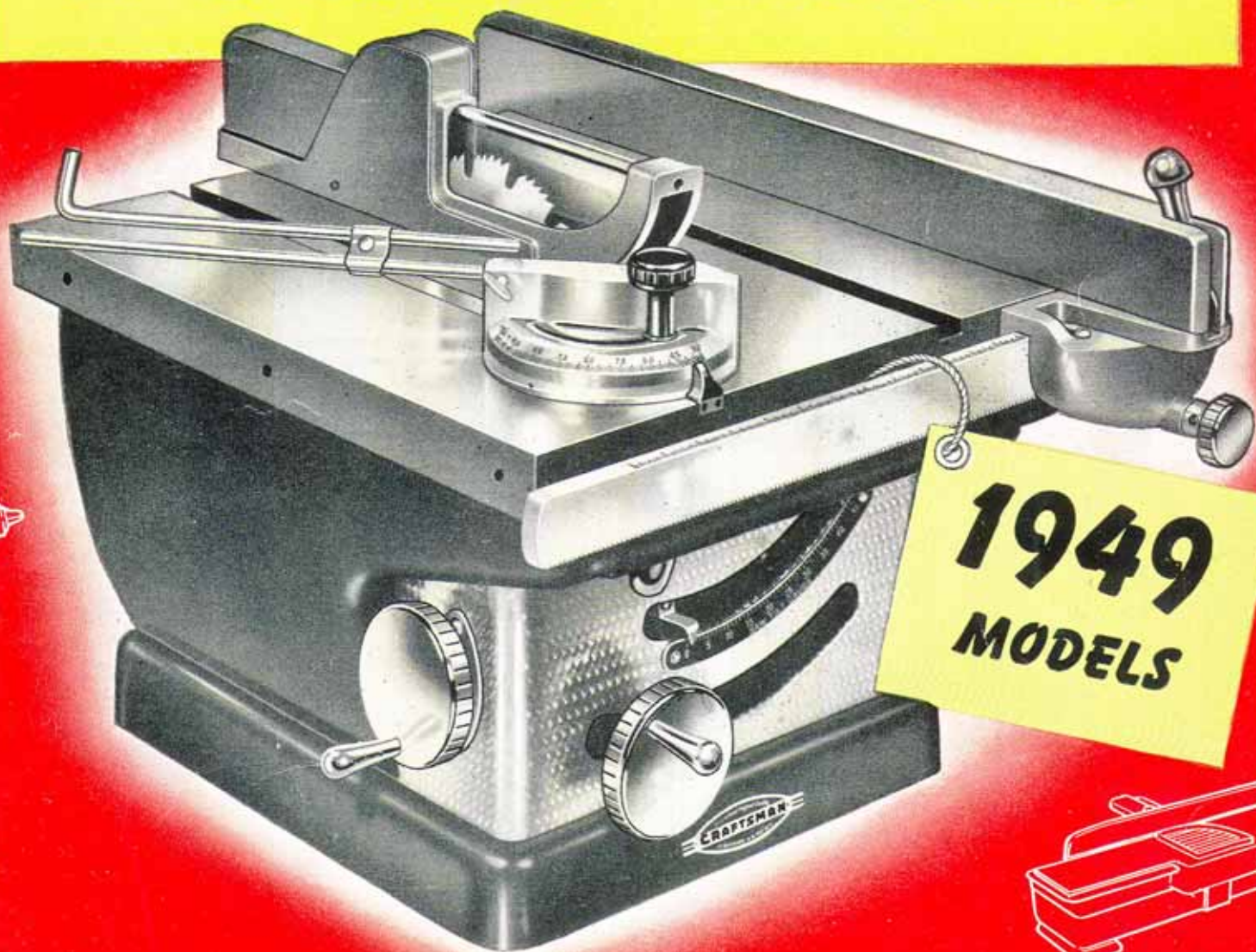

SEARS, ROEBUCK and CO.

Satisfaction Guaranteed or Your Money Back . . .

— INDEX —

	Page		Page
ABRASIVES.....	42, 43	LATHES—	
AIR HAMMER.....	31	WOOD AND ACCESSORIES.....	14, 15
BAND SAWS.....	10, 11	METAL AND ACCESSORIES..	26, 27, 28, 29
BENCH SAWS.....	2, 3	MOTORS, ELECTRIC.....	36, 37
BUILDERS' SAWS.....	4	MOTOR RAILS.....	37
CHUCKS.....	24, 25	POLISHING HEADS.....	38
DRILL PRESSES.....	20, 21	POLISHING MATERIALS.....	42
DRILL PRESS ACCESSORIES.....	18, 19	ROTARY TOOL.....	41
DRILL SETS.....	19	SANDERS: BELT AND DISC.....	11
EASI-BILD PATTERNS.....	46, 47	PORTABLE BELT.....	12
ELECTRIC DRILLS.....	22, 23	PORTABLE DISC.....	13
FENDER REPAIR TOOLS.....	31	SAW BLADES AND ACCESSORIES.....	8, 9
FLEXIBLE SHAFTS.....	40	SHAPERS.....	17
GRINDERS.....	38, 39	TILTING ARBOR SAW.....	Inside Front Cover 1
HACK SAW, POWER.....	34	TIMBER SAW.....	33
HAND SAW, ELECTRIC.....	5	THICKNESS PLANERS.....	17
HAND TOOLS.....	48, 49	TOOL LAMP.....	37
INSTRUCTION BOOKS.....	8	V-BELTS.....	44
JIG SAWS.....	6, 7	VICES.....	35
JOINTER-PLANERS.....	16	WELDERS AND ACCESSORIES.....	30, 31, 32

Sears Easy Payment Plan

**Only a small down payment
... terms as low as \$5 a month**

You, like thousands of our customers, will find our Easy Payment Plan a convenient, economical way to get the power tools and accessories you want now ... to use and to enjoy while paying for them over the months ahead.

You don't have to have all ready cash, nor is it necessary to disturb your savings to buy CRAFTSMAN power tools and accessories ... the better quality merchandise ... from this new 1949 Power Tool Catalog. Everything, yes everything, we sell regardless of price is available on Easy Terms. The total purchase, however, must amount to \$20.00 or more (\$10.00 if you already have an open account). A small down payment with your purchase and the balance in convenient monthly payments brings you the things you want when you need them. Any of our salespeople will be glad to give you further details.

Important Notice about Prices

The low prices in this catalog will be maintained if possible. However, because of the uncertainty of raw material markets we cannot guarantee to maintain the prices shown, and we reserve the right to increase the price of any item if it becomes necessary to do so.

Furthermore, should the Federal Government or any State increase by taxes or otherwise the cost or selling price of any of the merchandise shown in this book, we reserve the right to add such taxes or other increases of cost or selling to the prices shown in this catalog.

SEARS GUARANTEE

- TO DELIVER ALL MERCHANDISE SAFELY
- TO SATISFY YOU PERFECTLY

We guarantee that every article in this catalog is honestly described and illustrated.

We guarantee that any article purchased from us will give you the service you have a right to expect.

If for any reason whatever you are not satisfied with any article purchased from us, we want you to return it to us at our expense.

We will then exchange it for exactly what you want, or will return your money.

SEARS, ROEBUCK AND CO.

CRAFTSMAN "100"

NOW CRAFTSMAN offers you the most important and indispensable wood working power tool in TWO sizes ... an 8- and 10-inch bench saw. These CRAFTSMAN Tilting Arbor Bench Saws are tough, rugged, powerful saws and are precision built to do accurate, high quality continuous production work.

Work stays level. No more holding lumber at an awkward, uncomfortable angle! The blade and arbor tilt 0 to 45 degrees ... the table and work always stay level. Saw blade and arbor are rigidly supported in massive cradle and trunnions ... raise and lower to vary depth of cut ... lock at any desired angle. No twisted belt ... motor tilts with the blade.

Exceptionally large table. Heavy cast semi-steel; precision ground. Has removable insert for dadoing or sanding. Quick-acting, self-squaring rip fence locks at both ends with one handle; can be used on either side of blade. Vernier adjustment. Grooved on both sides for right or left hand miter cuts. Cuts all angles including compound miters. Accurate miter gauge has stop rods for repetitive cuts.

Automatic leveling guard. Tilts with the blade. Has transparent plastic insert ... protects the operator ... permits him to see work. Guard equipped with non-kick back pawls and splitter blade. Has built-in sawdust chute and guard.

SPECIFICATIONS for 8-inch model:

- Depth of cut, maximum..... 2 3/4 inches
- Blade, combination type—size..... 8 inch diameter bore..... 3/4 inch
- Table size..... 18x20 inches
- Table size, with front extension (not included)..... 18x27 inches
- Dado capacity: with 6-inch dado saw width..... 1 3/8 inch depth..... 1 3/4 inches
- Bearings..... Two sets precision ball
- Arbor speed recommended approx..... 4200 R.P.M.
- Motor recommended, minimum..... 1/2 H.P. 3450 R.P.M.
- Machine pulley (included)..... 2 1/2 inches
- Motor pulley (included)..... 3 inches
- Mounting dimensions..... 11 3/4 x 13 1/4 inches
- Over-all dimensions: Height 17 1/4 inches; width 20 1/2 inches; length 26 3/4 inches.

- A 99 AM 2240—8-inch model without motor. Shipping weight 140 pounds..... **\$84.50**
- 99 AM 2249—8-inch model with 3/4 H.P. capacitor 3450 R.P.M., 110-120 volt 60 cycle A.C. motor. Shipping weight 188 pounds..... **\$123.45**

SPECIFICATIONS for 10-inch model:

- Depth of cut, maximum..... 3 3/4 inches
- Blade, combination type—size..... 10-inch diameter bore..... 3/4 inch
- Table size..... 20x27 inches
- Dado capacity: with 6-inch dado saw width..... 1 3/8 inch depth..... 1 3/4 inches
- Bearings..... Two sets precision ball
- Arbor speed recommended..... 3450 R.P.M.
- Motor recommended, minimum..... 3/4 H.P. 3450 R.P.M.
- Machine pulley (included)..... 2 1/2 inches
- Motor pulley (included)..... 2 1/2 inches
- Mounting dimensions..... 11 3/4 x 13 1/4 inches
- Over-all dimensions: Height 18 1/2 inches; width 21 1/2 inches; length 33 3/4 inches.

- B 99 AM 2241—10-inch model without motor. Shipping weight 160 pounds..... **\$99.50**
- 99 AM 2250—10-inch model with 3/4 H.P. capacitor 3450 R.P.M., 110-120 volt 60-cycle A.C. motor. Shipping weight 208 pounds..... **\$138.45**

C **Table Extension Bracket.** For side extension on above 8- and 10-inch bench saws. Comes packed one bracket per package.

9 A 2253—Shipping weight 1 lb. 5 oz..... **90c**

D **Table and Rip Fence Extension.** For above 8-inch saw only. Increases table size to 18x27 inches.

99 A 02245—Shipping weight 18 lbs..... **\$9.95**

E **Dado Insert.** For 8 or 10-inch bench saws above.

9 A 2212—Shipping weight 12 oz..... **98c**

F **Sanding Insert.** For above 8- or 10-inch saws.

9 A 2283—Shipping weight 12 oz..... **98c**

Tilting Arbor Bench Saws in two sizes



A
\$84.50
CASH
Without Motor
\$8.50 DOWN ON
TERMS

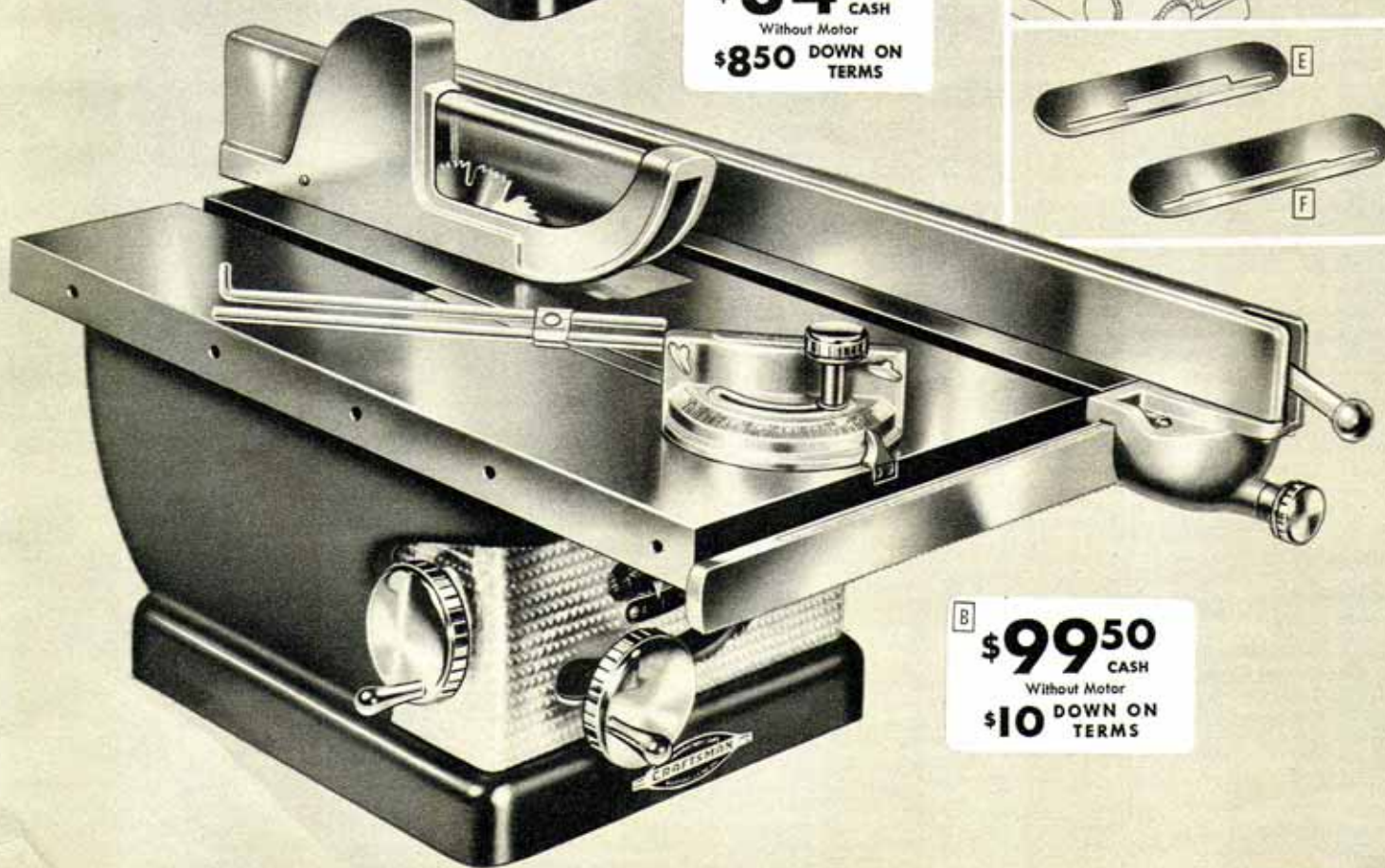
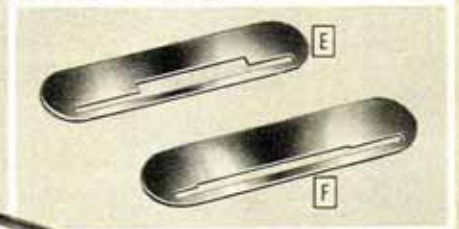
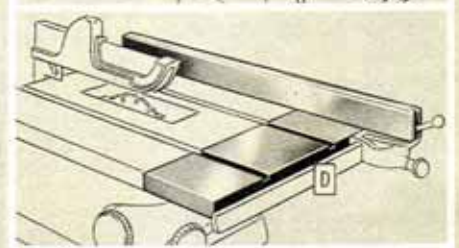
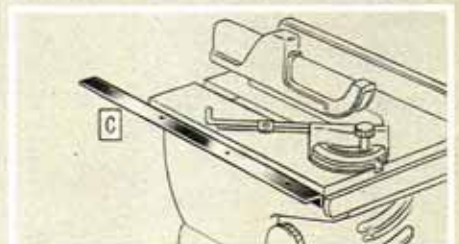

B
\$99.50
CASH
Without Motor
\$10 DOWN ON
TERMS

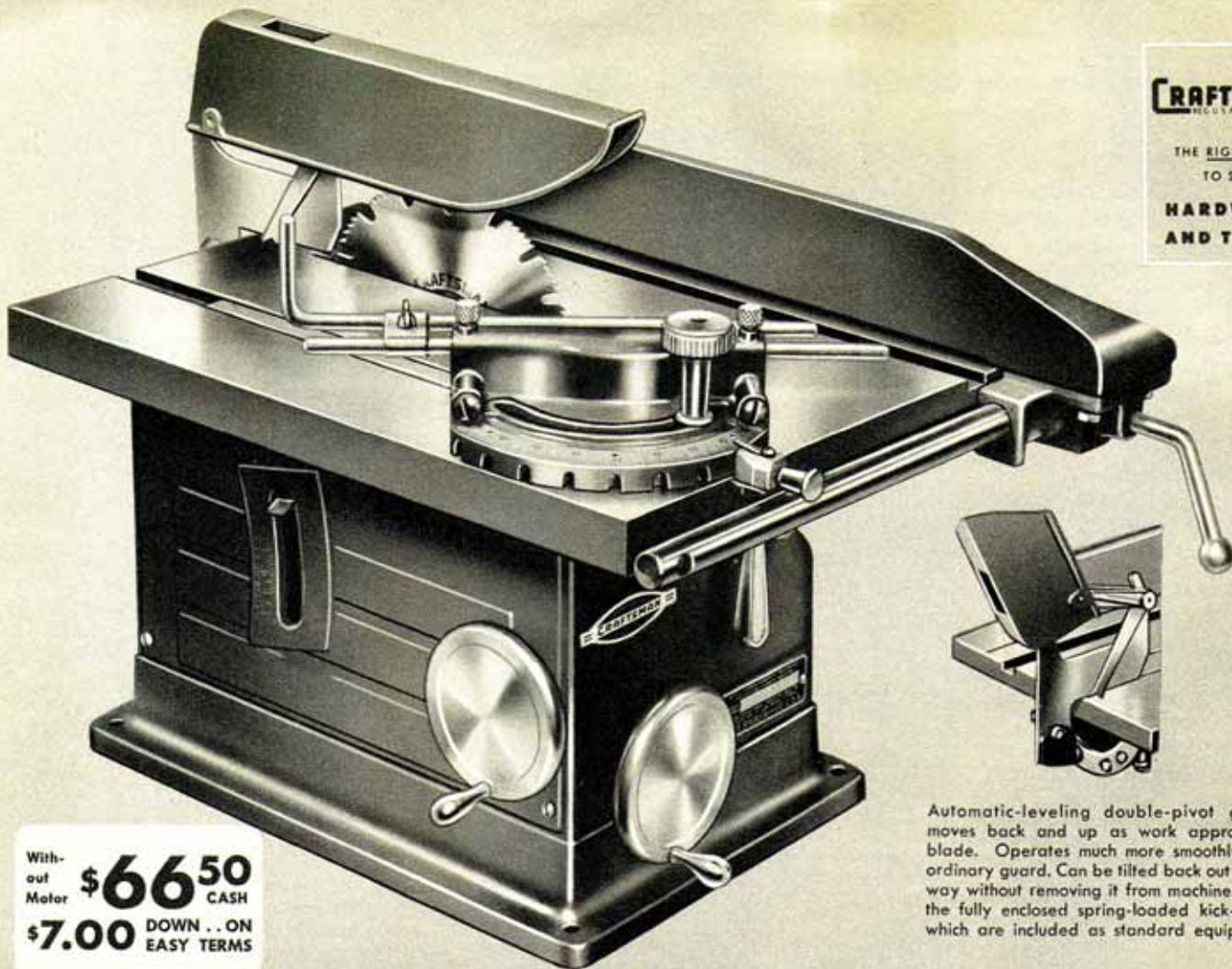
CRAFTSMAN
REG. U.S. PAT. OFF.THE RIGHT WAY
TO SAY**HARDWARE
AND TOOLS**

Without
Motor **\$66.50** CASH
\$7.00 DOWN . . ON
EASY TERMS

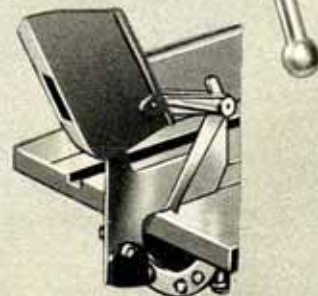

Automatic-leveling double-pivot guard moves back and up as work approaches blade. Operates much more smoothly than ordinary guard. Can be tilted back out of the way without removing it from machine. Note the fully enclosed spring-loaded kick-backs which are included as standard equipment.

CRAFTSMAN "80" 8-inch Tilting Table Saw

Has maximum depth of cut of 2½ inches

Woodworkers . . modelmakers . . patternmakers . . building maintenance men . . home craftsmen! Here is the ideal saw for you men who want a sturdy, accurate tool. The CRAFTSMAN 8-inch tilting table bench saw meets the most rigid demands of amateur and professional craftsmen and industrial shops. It's big, rugged . . . a real brute of a tool. Heavy duty, too! It has the famous CRAFTSMAN quality in every detail. And it's priced so you can afford it. Check the following specifications and features for yourself. You'll agree it's an outstanding tilting table bench saw! Just the one you need for your work and your workshop.

Large capacity. Maximum depth of cut is 2½ inches. Depth of dado cut is 1½ inches and width of dado cut is ¾-inch maximum. With this saw, you can miter up to 2-inch lumber.

Ample working surface. The table, a full 15¼ x 18¾ inches, is sturdily made of heavy cast iron, smoothly ground and polished. It's large enough for you to handle good sized work. Table is rib braced for added strength and is grooved on both sides of blade for either left or right hand miter cuts. Removable insert for dadoing.

Table tilts to any angle up to 45 degrees on oversize double trunnions. Table tilting easily and quickly controlled by convenient handwheel and self-locking screw. Table may be manually locked if desired. The accurate gauge shows angle of tilt.

Precision high speed ball bearing operation. Arbor spins freely on two sets of ball bearings. Bearings are accurately ground and finished, packed in grease and sealed against dirt and grit. This assures you of smooth, long-life operation.

8-inch combination blade can be used as rip, crosscut or miter blade. Expertly made of heat treated "Super-Tuff" steel. Blade can be raised and lowered by convenient hand wheel control.

SPECIFICATIONS:

- Depth of cut, maximum 2½ inches
 - Table size 15¼ x 18¾ inches
 - Table size with extensions (not included) 26¾ x 23¾ inches
 - Dado capacity, maximum, with 6-in. head:
 - Width . . . ¾ inch
 - Depth . . . 1½ inches
 - Blade Diameter 8 inches
 - Bore ½ inch
 - Bearings 2 sets ball
 - Recommended arbor speed (approx.) 4400 R.P.M.
 - Motor recommended (min.) ½ H.P. 3450 R.P.M.
 - Machine pulley (included) 2 inch
 - Motor pulley (not included) 2½ inch
 - Mounting dimensions 9¾ x 14¾ inches
 - Over-all dimensions: Height 14½ inches; width 19 inches; length 24½ inches.
- With blade, machine pulley, rip fence, splitter; automatic-leveling double-pivot guard with enclosed spring loaded non-kick-back pawls, miter gauge and stop rods for repetitive cut-offs.
- 99 AM 2199—CRAFTSMAN 8-inch Bench Saw without motor. Shipping wt. 99 lbs. **\$66.50**
- 99 AM 2197—CRAFTSMAN 8-inch Bench Saw with ½-H.P. 3450 RPM ball bearing capacitor 110-120-volt 60-cycle A.C. motor, 2¼-in. motor pulley, ½ x 44 in. V Belt. Shpg. wt. 135 lbs. **\$97.50**

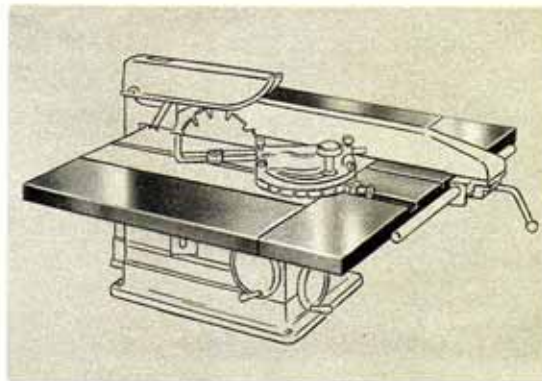

Table Extension Set for above saw

Increases the working surface of your 99 AM 2199 bench saw table to 26¾ x 23¾ inches. Gives an additional 5¾-inch table surface ahead of saw blade. Fits 99 AM 2199 saw perfectly . . . gives you a solid working surface that permits you to handle larger work than you could without this extension set. Set includes: two cast iron front extensions, smooth ground and polished; two stamped steel side extensions; one rear support bar and all the necessary bolts and fittings needed to install extensions.

99 A 02232—Shipping weight 31 lbs. **\$15.95**

Replacement Blades

Eight-inch combination type circular saw blades for use on 99 AM 2199 saw are listed and shown on page 8 of this 1949 CRAFTSMAN Power Tool Catalog. Buy yours today!

Easy Terms

Short of cash? Buy your power tools on Sears Easy Terms. A small amount down; balance payable monthly . . . see inside front cover.



Without motor **\$39⁰⁰** CASH
\$4 DOWN . . ON SEARS EASY PAYMENTS

CRAFTSMAN "80" Tilting Table Saw

Rugged heavy duty type . . . our finest 7-inch tilting table saw. Massive, heavy cast iron construction throughout.

Bigger, heavier table. 16 3/16 x 12 3/4-inch table tilts 0 to 45 degrees . . . locks in angle position. Grooved on both sides of blade for mitering. Has removable insert for dadoing. Self-aligning rip fence may be used on either side of blade.

Depth of cut adjustable 0 to 2 1/4 inches. 7-inch combination blade with 3/8-inch bore. Table may be raised and lowered by geared mechanism. Convenient hand wheel controls depth of cut. Streamlined, metal guard over blade.

Massive cast iron base completely encloses mechanism. Self-lubricating oilite bronze bearings; oil well around each.

Comes with guard, splitter, miter gauge, rip fence and blade.

SPECIFICATIONS:

- Depth of cut, maximum 2 1/4 inches
- Blade 7-inch combination type with 3/8-inch bore
- Table size 12 3/4 x 16 3/16 inches
- Table size with extensions (not included) . . . 23 3/8 x 16 3/16 in.
- Dado capacity, max., with 6 inch head 3/16 inch
- Bearings Two self-lubricating oilite bronze
- Recommended arbor speed (approx.) 4400 R.P.M.
- Motor recommended, minimum 3/4 H.P. 1750 R.P.M.
- Machine pulley (included) 2 inch
- Motor pulley (not included) 5 inch
- Mounting dimensions 11 1/2 x 6 3/8 inches
- Over-all dimensions: Height 14 1/4 inches; width 12 3/4 inches; length 20 3/8 inches

99 A 02342—Without motor. Shpg. wt. 62 lbs. \$39.00

99 AM 2378—With 3/4 H.P. 1750 R.P.M. split phase ball bearing motor for 110-120 volt A.C. 5-in. motor pulley, 1/2 x 42 inch V Belt. Shpg. wt. 92 lbs. \$58.00



Without motor **\$27⁵⁰** CASH
\$3 DOWN . . ON SEARS EASY PAYMENTS

DUNLAP 7-inch Tilting Table Saw

The ideal saw for home or small workshop use. It does a fine job of crosscutting, ripping, mitering and grooving.

Maximum depth of cut 2 1/4 inches. Has 7-inch combination blade. Ball crank mechanism raises and lowers blade.

14 1/2 x 10 5/16-inch table tilts 0 to 45 degrees. Table smooth ground; made of cast iron. Removable insert for dadoing. Self-aligning rip fence locks in position. Adjustable guard.

Complete with guard, splitter, miter gauge, rip fence and blade.

SPECIFICATIONS:

- Depth of cut, maximum 2 1/4 inches
- Blade 7 inch rip blade with 3/8-inch bore
- Table size 14 1/2 x 10 5/16 inches
- Extensions Not available
- Dado capacity, max., with 6 inch head 3/16 inch
- Bearings Two self-lubricating oilite bronze
- Recommended arbor speed (approx.) 4500 R.P.M.
- Motor recommended, minimum 3/4 H.P. 1750 R.P.M.
- Machine pulley (included) 1 1/2 inch
- Motor pulley (not included) 4 inch
- Mounting dimensions 9 3/8 x 4 3/8 inches
- Over-all dimensions . . . Height 11 1/2 inches; width 10 1/8 inches; length 17 3/8 inches.

99 A 02169—Without motor. Shpg. wt. 36 lbs. \$27.50

99 AT 2165—With 3/4 H.P. 1750 R.P.M. split phase ball bearing motor for 110-120 volt A.C. 4-inch motor pulley, 1/2 x 40-inch V Belt. Shpg. wt. 66 lbs. \$46.00

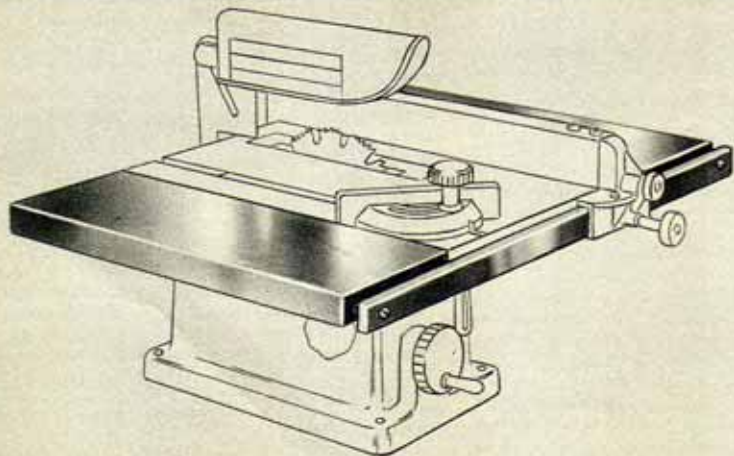

Table Extension

\$565 Designed for use with CRAFTSMAN 7-inch heavy duty tilting table saw, 99 A 02342, above. Fits perfectly. Provides much bigger working surface so you can handle larger work with greater ease. Total working surface of saw table increased from 12 3/4 x 16 3/16 inches to 23 3/8 x 16 3/16 inches. Set consists of two smooth steel side extensions, each 5 3/8 x 16 3/16 inches in size, plus all necessary support bars and fittings for attaching extensions to saw. One extension is mounted on each side of blade. Rip fence may be used over the entire length of the extensions. Extensions easily installed.

9 A 2174—Shipping weight 7 lbs. 8 oz. Set \$5.65

Motor Pulleys and V-belts

Supplied with all saws with motor shown on these two pages. For V-belts, see page 44; for pulleys, page 45.



The blade, guard, arbor and motor are mounted on the rugged carriage that rolls smoothly on 6 ball bearing rollers . . . All working parts are below the table surface . . . out of the way

With-
out
Motor **\$104⁵⁰** CASH
\$10.50 DOWN . . ON
EASY TERMS

CRAFTSMAN "100" Builder's Saw

REG. U. S. PAT. OFF.

Heavy duty type to meet all your construction and production needs

Most outstanding builder's saw of the year! . . . perfect for cutting and ripping building materials, for cutting crating in shipping rooms and for making miter and dado cuts. Removable insert for dadoing. Sturdy steel frame, legs, and side panels welded into one solid unit . . . will withstand steady production use.

Extra large capacity. The 10-inch combination rip and crosscut blade allows you to make cuts up to 3 $\frac{1}{4}$ inches in depth. Saw travels full 15 $\frac{1}{2}$ inches. At any point in travel of saw the depth of cut can be easily adjusted by the large handwheel conveniently located at the front. Removable and adjustable saw guard raises and lowers with saw blade depending on depth of cut; also protects operator.

Lumber remains stationary. Forget about sliding long heavy lumber into the blade. Now . . . you simply hold lumber firmly on the table and move blade through it by pulling convenient handle. Cuts large heavy work faster, easier and more accurately than the ordinary bench saw.

Extra large table. 35x24-inch table top is one-piece steel, stamped and coined. Sturdy ribbing braces are welded to under sides. Equipped with two miter gauges: left hand is used when work is stationary and blade is pulled through work; right hand is used when blade is stationary for making shorter cuts. Rip fence locks at both ends for better squaring accuracy in cutting. It moves along table by pinion in rack under guide bar. Arbor is mounted on two roller type needle bearings.

SPECIFICATIONS:

- Depth of cut, maximum 3 $\frac{1}{4}$ inches
- Blade, combination type 10-inch diameter
3 $\frac{1}{2}$ -inch bore
- Bearings: arbor 2 sets of roller needle bearings
- Carriage rollers 6 sets of ball bearings
- Dado capacity: with 6-in. dado saw
- Width, maximum 1 $\frac{3}{4}$ inch
- Depth, maximum 1 $\frac{3}{4}$ inch
- Distance in front of blade (at miter gauge) . . . 15 in.

- Arbor speed recommended . . . (approx.) 4200 R.P.M.
- Motor recommended, min. 3 $\frac{1}{4}$ H.P., 3450 R. P. M.
- Machine pulley (included) 2 $\frac{3}{4}$ -inch double "V" groove
- Motor pulley (included) 3 in. double "V" groove
- Switch (included) 2 H.P. capacity
- Carriage travel, maximum 15 $\frac{1}{2}$ inches
- Miter cut, maximum 3 $\frac{1}{4}$ x15 inches
- Miter graduations L. H. 1° in 180° radius
- Miter graduations R. H. 1° in 180° radius
- Table height 33 inches
- Over-all dimensions: Height (including handle) 40 inches; length 42 $\frac{1}{2}$ inches; width 27 inches.
- 99AM2262—Without motor. Shpg. wt. 160 lbs. **\$104.50**
- 99AM2266—With 3 $\frac{1}{4}$ H. P. 3450 R.P.M. capacitor ball bearing, 110-120-volt, 60 cycle A. C. motor. Shpg. wt. 208 lbs. **\$143.45**
- 99 AM 2268—With 1 H.P. 1750 R.P.M. capacitor ball bearing, 110-120-volt, 60 cycle A.C. motor; two 3 $\frac{1}{2}$ x43 in. V-belts and 6 in. double groove motor pulley. Shipping weight 230 lbs. **\$160.50**

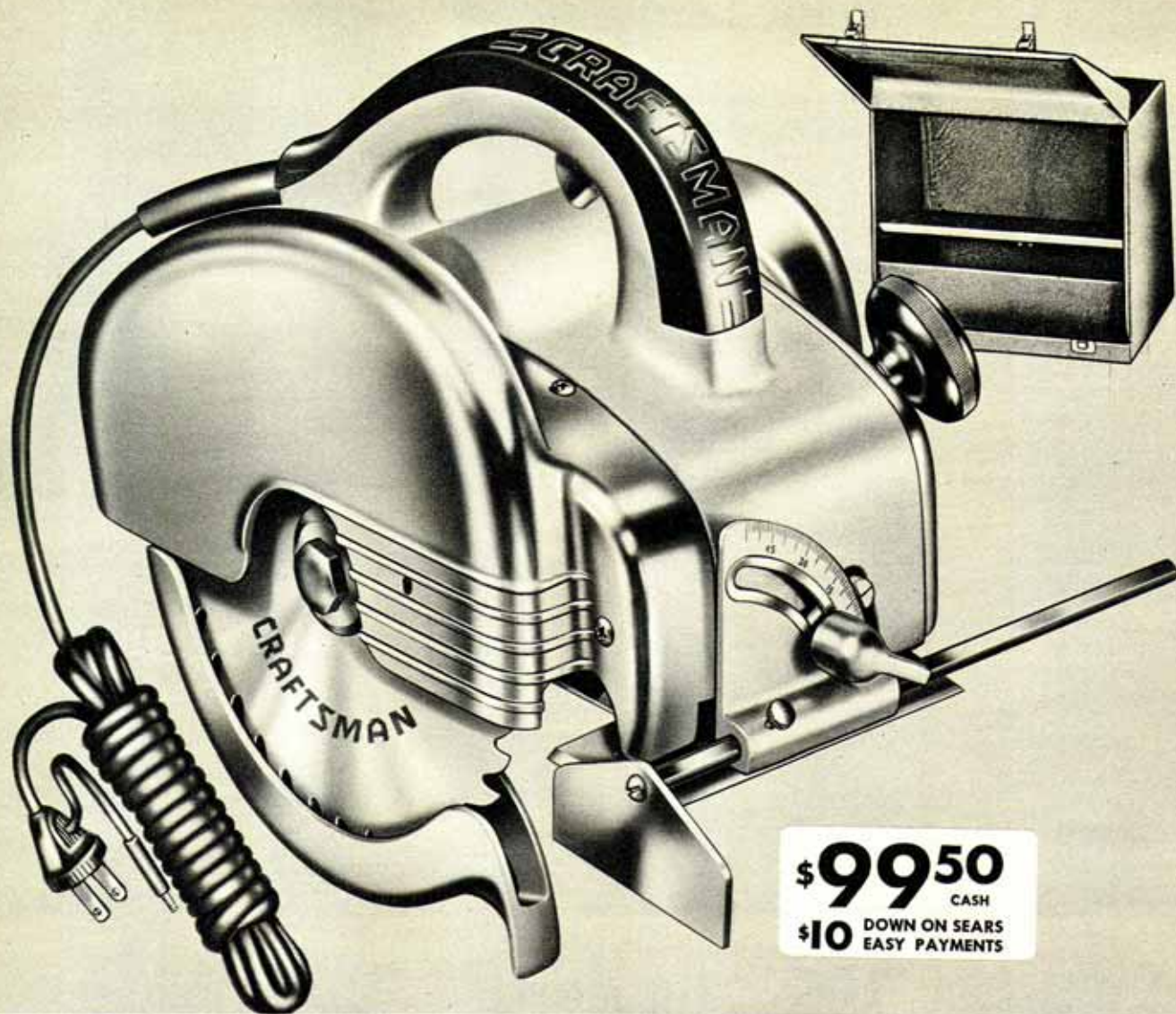

\$99⁵⁰ CASH
\$10 DOWN ON SEARS
 EASY PAYMENTS



Perfect-fitting straight and compound miter cuts quickly and easily cut right on the job with this portable handsaw.



2 3/4-in. depth of cut permits you to cut several pieces at once in vertical position ... up to 2-in. depth of cut at 45 degrees.



It's easy to cut large plywood panels; to notch and cut rafters, siding, and flooring. Saves you time and money.

CRAFTSMAN Electric Hand Saw

REG. U.S. PAT. OFF.

Cuts faster than any similar saw we know of . . . only \$10.00 Down

The rugged, portable electric saw that does any sawing operation 10 TIMES FASTER than ordinarily performed with a hand saw . . . actual tests proved it. And it's so easy to use. Do your ripping, crosscutting, mitering and notching and cutting rafters, flooring, panels and siding the modern speedy way . . . with a CRAFTSMAN 8-inch Electric Hand Saw. Tremendously useful in carpentry, building construction, crate and box making, etc.

Super-large capacity. The base is adjustable for depth of cut: From 0 to 2 3/4 inches in vertical position and 2 inches at 45 degrees. The 8-inch blade, mounted on right side for visibility and convenience, is protected at every angle by an automatic telescoping guard . . . rotates on needle bearings.

New close-coupled design. The motor and handle are mounted close to the blade . . . gives better balance . . . more efficient gear arrangement. Gears are made of helical cut alloy steel. One Zerk grease fitting

lubricates all the gears. Knob handle on the left side for two handed operation.

SPECIFICATIONS:

- Depth of cut, maximum: vertical position. 2 3/4 in. 45° position 2 inches
- Blade (included) diameter 8 inches bore 3/4 inch type combination
- Free blade speed 6400 R.P.M.
- Base adjustment: For depth of cut. 0 to 2 3/4 inches For angle of cut 45 to 90 degrees
- Bearings Double sealed SKF ball bearings
- Motor General Electric, universal; 110-120 volt 25 to 60 cycle A.C.-D.C.
- Switch Non-locking Trigger type, enclosed
- Sawdust blower Built-in
- Ripping Guide Built-in
- Over-all dimensions: Height (with handle) 11 1/4 inches; length 13 inches; width 9 inches

The lightweight frame is made of strong, die-cast aluminum alloy. Actual weight of this CRAFTSMAN Electric Hand Saw is only 19 pounds. A convenient steel carrying case is included with saw. Open-front type with shelf for carrying saw and space below for storing extra blades, cords, tools, etc. Size of case is 16x13 1/2 x 10 inches.

Complete with 8-inch blade, 10-foot 3 wire rubber covered cord, unbreakable plug, wrench and handy all steel carrying case. Shipping weight 38 lbs.

99 A 02560—CRAFTSMAN Electric Hand Saw . . . **\$99.50**

9 A 6455—Cut-off Wheel. For use on above saw. 8-inch diameter, 3/32-inch thick. Use for cutting tile, concrete, granite, cast iron, etc. Specify 1/2-inch bore. Shipping weight 8 ounces Each **\$1.69**

9 A 4940—CRAFTSMAN Combination Blade. For use on above saw. Made of tough saw steel. 8-inch diameter; 1/2-inch bore. Shpg. wt. 1 lb. **\$3.35**

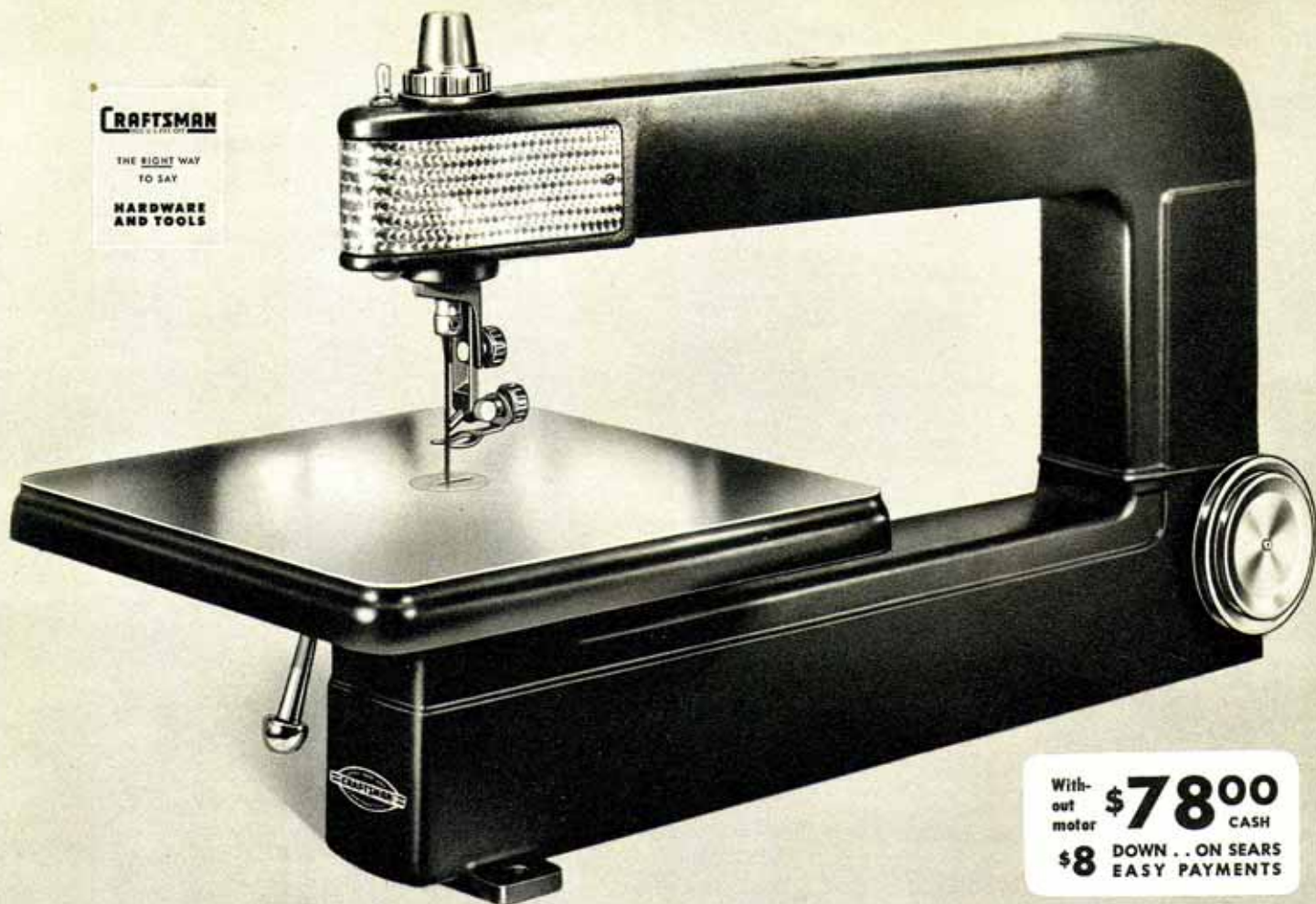
CRAFTSMANTHE RIGHT WAY
TO SAYHARDWARE
AND TOOLS

Without
motor \$**78⁰⁰** CASH
\$**8** DOWN . . ON SEARS
EASY PAYMENTS

CRAFTSMAN "100" Jig Saw

REG. U.S. PAT. OFF. Ball bearing equipped . . . 24-inch capacity

Woodworkers! Pattern makers! Printers! Engravers! Sign makers! Here's an extra large capacity jig saw . . . cuts to center of a 48-inch circle in wood up to 2-inches thick . . . that will be a valuable asset in your plant or shop. Besides sawing wood, this CRAFTSMAN "100" jig saw, with the sensational "Walking Beam" drive action, is ideal for sawing metals, plastic, fiberboard and other materials. Especially designed for making intricate cuts and for doing fine pattern work. Read the full explanation (at the right) of the "Walking Beam" drive action. You'll want a CRAFTSMAN 24-inch jig saw in your shop today.

Extra large size table. Notice the 16x16-inch adjustable table. Plenty of working surface there. And it can be tilted 45 degrees either to the right or left or it can be tilted to the front or rear. To make this jig saw more adaptable to the delicate inside or outside scrollwork or fretwork, the blade and chuck swivel a full 90 degrees.

Lifetime lubrication. No need to worry about burned out bearings . . . no spoiled work due to oil spots . . . this jig saw is permanently lubricated. Double row precision ball bearings on drive shaft. Entering cuts at sharp angles are possible because the new blade support guides the blade above and below the work . . . close to the working surface . . . reduces blade breakage, too. Narrow, almost tissue paper thin cuts are possible on this jig saw because of the smooth, exclusive "Walking Beam" drive action. The hold down foot prevents lifting work off the table on the upward stroke of the blade.

Built-in blower. A blower, located in the head, delivers a constant air blast through the upper chuck. Keeps your work free of sawdust. Ideal when following a pattern. Lamp, built in the head, lights up the working area. In actual operation, this CRAFTSMAN jig saw is practically vibrationless and noiseless. Vibration reduced by the use of "Walking Beam" drive action which eliminates the usual jerky return spring and crankcase.

Check the following specifications. It's just THE saw you need for your production work.

SPECIFICATIONS:

- Depth of throat 24 inches
 - Depth of cut, maximum, in wood 2 inches
 - in plastic 1½ inches
 - in brass ¾ inch
 - in aluminum and zinc ½ inch
 - Table size 16x16 inches
 - Table can be turned 90 degrees, tilts up to 45 degrees
 - Drive shaft has 2 rows precision ball bearings
 - Motor recommended, min. . . ¾ H.P. 1750 R.P.M.
 - Machine pulley (included) . . . 5 and 6-in. "V" type
 - Motor pulley (not included) . . . 2-inch and 3-inch
 - Speed 525 and 1015 R.P.M.
 - Work lamp (with cord and plug) . . . 7½ watt; built into the head; convenient switch
 - Sawdust blower Built into head
 - Mounting dimensions 5¼x30½x6 inches
 - Over-all dimensions: Height 21½ inches; length 39¾ inches; width 16½ inches
- The motor (not included) can be mounted above, below or behind the machine pulley. Pulley drive is at the rear on the side of the base. One 6-inch plain end blade included. Shpg. wt. 124 lbs.
 99 AM 2344—24-inch jig saw without motor . . \$78.00
 99 AM 2393—24-inch jig saw with ¾ H.P. 1750 R.P.M. split phase ball bearing 110-120 volt, 60-cycle A.C. motor. 2-in. and 3-in. motor pulley, ¾x36-in. V belt. Shpg. wt. 148 lbs. \$90.00

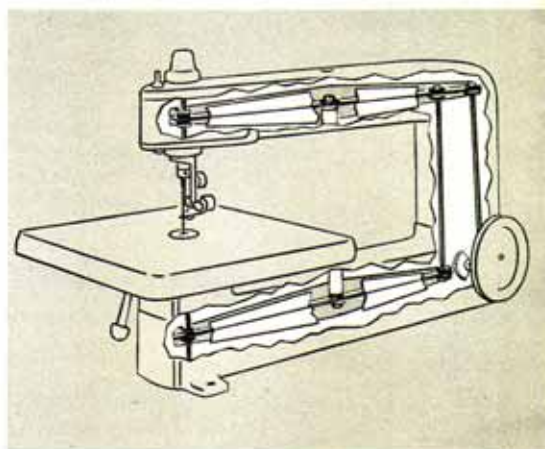

"Walking Beam" Action

"Walking Beam" type of drive action is an "H" shaped stamped channel section, an exclusive feature of this new CRAFTSMAN "100" Jig Saw. This drive action operates through double bearing guides above and below blade. Eliminates the need for return spring (power delivered in both up and down stroke). Maintains uniform tension of blade on both up and down stroke to give blade longer life, even when using fine fret or jewelers' blades. This new design greatly minimizes blade breakage and vibration. It also eliminates any need for crankcase. And you'll find it's practically noiseless in operation.

CRAFTSMAN
REG. U.S. PAT. OFF.

"80" Jig Saw

18-inch work capacity

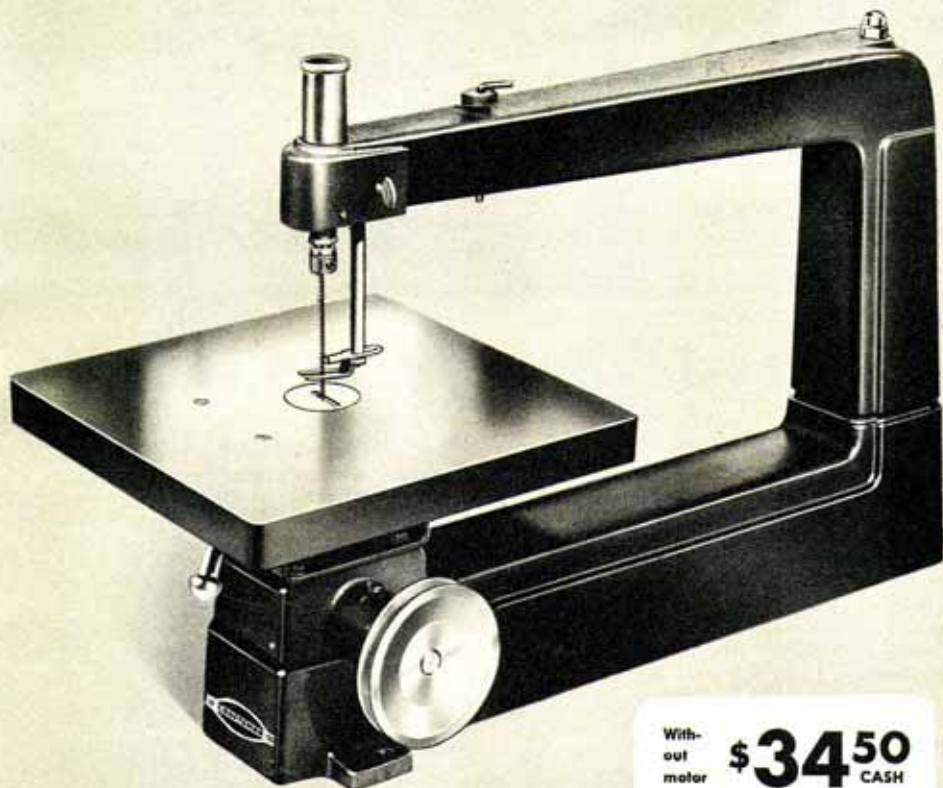

- Cuts to center of 36 inch circle
- Handles material up to 2 inches thick

This CRAFTSMAN 18-inch Jig Saw is especially designed for your professional or hobby use. 12x12-inch table provides a large working surface. Smooth ground, cast iron table can be tilted up to 45°... locked in position.

Modified Scotch yoke action runs in a bath of oil. This gives the saw a well balanced, smooth cutting action. The new, strong blade chuck rotates 90 degrees; enables you to rip pieces longer than 18 inches. No twisting of blade... the shoe in chuck gives a firm grip between the blade and the clamping member.

Fully enclosed coil spring keeps the blade tight for smoother operation. Equipped with adjustable hold down and blade guides. Built-in air pump clears sawdust from working area. Oiltite bronze main bearings.

SPECIFICATIONS:

- Depth of throat.....18 inches
- Depth of cut, maximum.....2 inches
- Table size.....12x12 inches
- Machine pulley (included).....4-inch single groove
- Motor pulley (not included).....2 inches
- Motor recommended, minimum ¼ H.P. 1750 R.P.M.
- Speed.....860 R.P.M.
- Sawdust blower.....Built into head
- Mounting dimensions.....5½x22⅞ inches
- Over-all dimensions: Height 17½ inches; length 29 inches; width 12 inches.

Strong cast iron frame has three point mounting of base which eliminates cross strain. Upper arm is removable for saber sawing and filing. Uses five or six-in. plain end blade (one included). Shpg. wt. 72 lbs.

99 AM 2315—18-inch jig saw without motor.....\$34.50

99 AM 2360—18-inch jig saw with ¼ H.P. 1750 R. P. M. split phase ball bearing 110-120 volt, 60 cycle

A. C. motor. 2-in. motor pulley, ½x66-in. V belt. Shipping weight 102 pounds.....\$53.50

Without motor **\$34.50** CASH
\$3.50 DOWN.. ON EASY TERMS



CRAFTSMAN "40" Magnetic Jig Saw

Our popular, low priced jig saw that operates without a motor or belt. Just plug it in... snap the new on-off switch and go to work. That's all there is to it. Magnetic power unit, in the base, moves blade so rapidly... 7200 strokes per minute... that super-smooth edges are produced. No sanding necessary! Cuts to the center of a 22-in. circle.

\$12.95

The safe, easy-to-operate hobby tool that every member of the family can use and enjoy. Less dangerous for a child to use than a hammer. *It's more than a toy. It's a rugged, well-made power tool.* Just the thing for making hundreds of articles from wood, plywood, thin plastic, or metal.

No motor to buy! No belt! No gears! No oiling necessary... you don't have to worry

about parts burning out from lack of oil... or about oil spots on work. Portable too... can be used anywhere. So clean you can use it on the kitchen table.

SPECIFICATIONS:

- Depth of throat.....11 inches
- Depth of cut, maximum in wood... ½ inch
- Table size.....8¾x8 inches
- Over-all dimensions: Height 10½ inches, width 8½ inches; length 16¾ inches

All metal construction; non-slip rubber feet. Comes complete with one 5-inch pin-end blade. 5½ ft. of connecting cord and operating instructions. Use on 110-120 volt 50-60 cycle A. C.

99 A 02632—Shpg. wt. 14 lbs.....\$12.95

9 A 2690—Extra blades for above jig saw, 6 blades, each 5 in. long. Shpg. wt. 1 oz....25c



CRAFTSMAN "40" Jig Saw

- Cuts to center of 24-inch circle
 - Handles work up to 1 inch thick
- \$18.00**

A smooth operating small jig saw. Just the saw for use in your hobby shop or home work shop. This Jig Saw gives you a full 9x9-inch smooth ground cast iron table... can be tilted to any angle up to 45 degrees... can be locked in angle position.

Balanced modified Scotch yoke action runs in a bath of oil. The fully enclosed coil type spring eliminates blade whip. Uses 5-inch pin type blade (one included). Adjustable blade guide and hold down.

SPECIFICATIONS:

- Depth of throat.....12 inches
- Depth of cut, maximum.....1 inch
- Table size.....9x9 inches
- Machine pulley (included).....4-inch single groove
- Motor pulley (not included).....2 inch
- Motor recommended, minimum ¼ H.P., 1750 R.P.M.
- Speed.....860 R.P.M.
- Mounting dimensions.....16¾x4¼ inches
- Over-all dimensions: Height 14½ inches; length 17¾ inches; width 9 inches. Shpg. wt. 32 lbs.

99 A 02179—12-in. jig saw without motor.....\$18.00

99 AT 2184—12-in. jig saw with ¼ H.P., 1750 R.P.M. split phase sleeve bearing 110-120 volt, 60 cycle A. C. motor. 2-in. motor pulley, ½x54-in. V belt. Shpg. wt. 56 lbs.....\$29.50



Circular Saws . . . precision heat treated

Cross and Rip Saws

A CRAFTSMAN. Professional quality. Made to stand up under day-after-day production work in factories and shops. Made of special "Super-Tuff" steel, precision heat treated. Hammered to correct tension. Deep gullets to clear out sawdust. Expertly hand set and filed. State center hole size and diameter wanted.

9 A 4925 CRAFTSMAN Crosscut					
Diam., in.	Gauge	Center Hole, in.	R.P.M.	Shpg. wt.	Each
6	18	1/2 or 3/8	6830	8 oz.	\$2.50
7	18	1/2 or 3/8	6500	13 oz.	2.95
8	18	1/2 or 3/8	5700	1 lb.	3.35
10	16	3/4 or 1	4570	1 lb. 12 oz.	4.25
12	15	3/4 or 1	3810	2 lbs. 11 oz.	5.50

9 A 4926 CRAFTSMAN Rip					
Diam., in.	Gauge	Center Hole, in.	R.P.M.	Shpg. wt.	Each
6	18	1/2 or 3/8	6830	8 oz.	\$2.50
7	18	1/2 or 3/8	6500	13 oz.	2.95
8	18	1/2 or 3/8	5700	1 lb.	3.35
10	16	3/4 or 1	4570	1 lb. 12 oz.	4.25
12	15	3/4 or 1	3810	2 lbs. 11 oz.	5.50

Flat-ground Combination Saws

A combination saw is the handiest of all circular saws. Practically three saws in one. Can be used equally well for crosscutting, ripping or mitering in hard or soft wood. Professional quality.

B CRAFTSMAN. Special "Super-Tuff" steel accurately heat treated and hardened . . . far superior to ordinary high carbon steel. Hammered for proper tension. Expertly hand set and filed.

9 A 4937 CRAFTSMAN Combination					
Diam., in.	Gauge	Center Hole, in.	R.P.M.	Shpg. wt.	Each
6	18	1/2 or 3/8	6830	8 oz.	\$2.50
7	18	1/2 or 3/8	6500	13 oz.	2.95
8	18	1/2 or 3/8	5700	1 lb.	3.35
10	16	3/4 or 1	4570	1 lb. 12 oz.	4.25
12	15	3/4 or 1	3810	2 lbs. 9 oz.	5.50

9 A 4935—7-inch Combination Blade for our former model Electric Hand Saw 2186 which has diamond shaped arbor. (Not illustrated.) Shipping weight 12 ounces. \$2.95

Hollow-ground Saws

C CRAFTSMAN Combination type. Taper grinding makes this the best saw for all-round work. Runs with less set. Makes the smoothest cut of any circular saw . . . smooth enough to glue without sanding. Specially filed for ripping, crosscutting or mitering. Special "Super-Tuff" steel, heat treated for toughness . . . far superior to ordinary high carbon steel . . . stays sharp much longer. 3-gauge taper grinding provides ample clearance for free, easy cutting. Hammered for proper tension. Ideal for fine woodworking.

9 A 4939—State center hole size and diameter of saw wanted when ordering.

Diam., in.	Gauge Taper	R.P.M.	Center Hole, in.	Shpg. wt. Lbs. Oz.	Each
6	16 to 19	6830	1/2 or 3/8	8	\$4.25
7	15 to 18	6500	1/2 or 3/8	12	5.10
8	15 to 18	5700	1/2 or 3/8	1	6.10
10	14 to 17	4570	3/4 or 1	10	7.75
12	13 to 16	3810	3/4 or 1	2	11.25

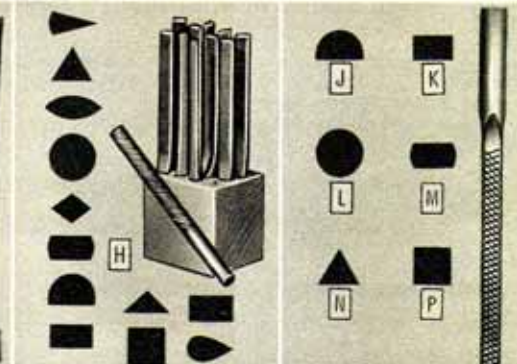

Power Tool Instruction Books

D The Wood Lathe. Handy CRAFTSMAN power tool instruction book that explains the construction and operation of the wood lathe. It's jam-packed with helpful hints and a world of technical and general information. Enables even the novice to do excellent work. It contains over 100 actual photographs and step-by-step illustrations. Tells how to turn spindles, how to do elementary metal turning, how to do grinding, sanding, finishing and many other operations. Easy to read and understand. Paper bound. 32 pages. *Postpaid.* 9 A 2920—(Shipping weight 2 ounces) 35c

E The Drill Press. A superb CRAFTSMAN manual for the home craftsman and shop owner. Explains in detail the construction features and operation of the drill press. Over 100 actual photographs and step-by-step illustrations explain vividly how to do drilling, shaping, sanding, mortising, dovetailing, routing and carving. Describes completely and accurately the uses of accessories and suggests many helpful homemade aids that will help you make and save money. Paper bound. 32 pages. *Postpaid.* 9 A 2921—(Shipping weight 2 ounces) 35c

F The Bench Saw and Jointer. CRAFTSMAN instruction and information manual that describes the construction and over 100 operations of the circular saw and jointer. Photographs and step-by-step illustrations tell you exactly what to do and how to do it. Will help to make your bench saw and jointer more useful. Paper bound. 32 pages. *Postpaid.* 9 A 2923—(Shipping weight 2 ounces) 35c

G Metal Lathe Manual. A complete, up-to-date manual of metal lathe operations and machinists' tables. Easy to follow directions give you a sound, practical explanation of the construction of the metal lathe. Ideal book for students, apprentices, machinists and experienced lathe operators. Replete with actual photographs and pen and ink drawings. Index tabs separate each section. Paper bound; spiral back. 234 pages. *Postpaid.* 9 A 2925—(Shipping weight 11 oz.) \$1.40 9 A 5411—224-page Welders' Handbook (not illustrated). Helpful, easy-to-understand manual of oxyacetylene welder operation, construction and maintenance. *Postpaid.* \$3.50

Saw File Sets

H CRAFTSMAN Jig Saw File Set. Handy set of 12 jig saw files. Fit all standard makes of jig saws. Help eliminate tedious hand filing on metal or wood patterns dies, scroll work, etc. 3 1/4 in. long with 1/4-in. round shank. Swiss pattern, size 00, sharp, deep-cut teeth. Set includes: 3 pillar files, 1 three-square file, 1 square file, 1 round file, 1 crochet file, 1 quarter-round file, 1 triangular file, 1 diamond file, 1 knife file and 1 round back file. In wooden box. 9 A 6778—Shipping weight 12 ounces \$7.25

I Special Jig Saw Files. Expertly made from special steel heat treated, tempered and hardened. Strong, deep-cut teeth stay sharp and wear long. Use of these files eliminates that tedious hand filing. Have 1/4-inch square shanks. Shipping weight, each, 1 ounce. 9 A 2742—Half Round File Each 59c 9 A 2740—Pillar File Each 59c 9 A 2738—Round File Each 59c 9 A 2739—Crochet File Each 59c 9 A 2737—3-Square File Each 59c 9 A 2741—Square File Each 59c

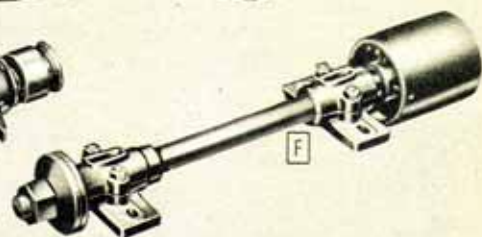
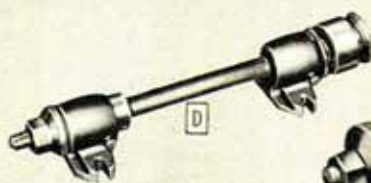
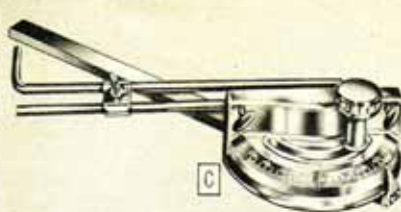
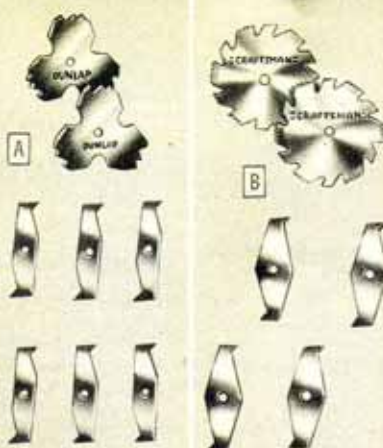

NOTE
Above view shows dado saw assembled. With dado saws, you can use your bench saw for dadoing, grooving, rabbeting, tenoning, etc.

Dado Sets, Miter Gauge, Saw Mandrels

A DUNLAP 5 1/2-inch Dado Set. Tempered high carbon steel. Complete set includes: two 3/2-inch thick outside saws, and six 1/16-inch inside chippers. Shipping weight 1 pound 10 ounces.
 9 A 4888—With 3/8-inch hole. Set \$4.95
 9 A 4889—With 3/4-inch hole. Set 4.95
 9 A 4884—Outside saw only. Specify 3/8 or 3/4-inch hole. Shipping weight 9 ounces. Each \$1.55
 9 A 4881—Inside Chipper only. Specify 3/8 or 3/4-inch hole. Shipping weight 3 ounces. Each 55c

\$495

B CRAFTSMAN 6-inch Dado Set. Precision ground perfectly matched chippers. Tempered steel Set includes two 3/4-inch thick outside saws, one 1/4-inch chipper, two 3/8-inch chippers, one 1/16-inch chipper. Shipping weight 3 pounds 8 ounces.
 9 A 4874—With 3/8-inch center hole. Set \$12.95
 9 A 4875—With 3/4-inch center hole. Set 12.95

\$1295

Separate Dado Saw Parts. Specify 1/2 or 3/8-inch hole.
 9 A 4876—Outside Saw. Shipping weight 8 oz. Each \$4.95
 9 A 4877—1/16-inch Chipper. Shpg. wt. 3 oz. Each 98c
 9 A 4878—3/8-inch Chipper. Shpg. wt. 3 oz. Each 1.55
 9 A 4879—3/4-inch Chipper. Shpg. wt. 3 oz. Each 1.75

C CRAFTSMAN Miter Gauge. Scaled from 30 to 90 degrees left and right. 3/4 x 3/8 x 15 3/8 inch bar fits in miter groove in table top. Fitted with adjustable stop rods for repetitive cuts. Chromium plated knobs; other parts have rust-resisting cadmium plated finish.
 9 A 2257—Shpg. wt. 4 lbs. \$4.95

\$495

D DUNLAP Bronze Bearing Mandrels. 2-in. double V-pulley Size 00 for flat belt, single or multiple V-belt drive. Steel shaft; stamped steel flanges. Set collar takes up end play. Oil plugs. 14 in. long.
 9 A 4946—Please state size
 Size 00, 3/8-in. shaft; turned to 3/4-in. at ends. Shpg. wt. 5 lbs. 5 oz. \$3.95
 Size 0, 3/4-in. shaft turned down to 3/4-in. at ends. Shpg. wt. 6 lbs. \$4.25

\$395

E CRAFTSMAN Ball-bearing Mandrels. Streamlined cast iron housing. Improved, compact design. Oversize precision ball bearings grease sealed against dirt.
 Size 00

\$605

9 A 4948—Size 00. 3/4-inch shaft turned down to 3/4-inch at ends. Length 9 1/2 inches. Shpg. wt. 3 lbs. 8 oz. \$6.05
 9 A 4949—Size 0. 3/4-inch straight shaft with 3/8-inch ends. Length 11 1/2 inches. Shipping wt. 4 lbs. \$6.40

F Heavy Duty Saw Mandrels. Precision built. High speed babbitted bearings. Machined steel collars. Cold rolled steel shaft. Set collar. With bolts. State size wanted.
 Size 00

\$325

Size	Pulley diameter and face	Shaft Size inches	Shaft Size at end inches	Shpg. wt.	99 A 04947 Left hand threads	99 A 04932 Right hand threads
00	2 x3	in. 16 x 3/8	1/2	7 lbs.	\$3.25	\$3.25
0	2 x3	in. 16 1/2 x 3/8	3/4	15 lbs.	4.65	4.65
1	2 1/2 x 3 1/2	in. 16 3/4 x 1/2	1	20 lbs.	5.85	5.85
2	3 x4	in. 19 x 1/2	1 1/2	24 lbs.	7.05	7.05
3	3 1/2 x 4 1/2	in. 21 1/2 x 1/2	1 3/4	30 lbs.	8.40	8.40
6	5 x6	in. 28 1/2 x 1 1/2	1 3/4	40 lbs.	13.45	13.45
7	5 1/2 x 6 1/2	in. 30 1/2 x 1 3/4	1 3/4	48 lbs.	15.50	15.50
8	6 x7	in. 32 1/2 x 1 3/4	1 3/4	60 lbs.	18.30	18.30

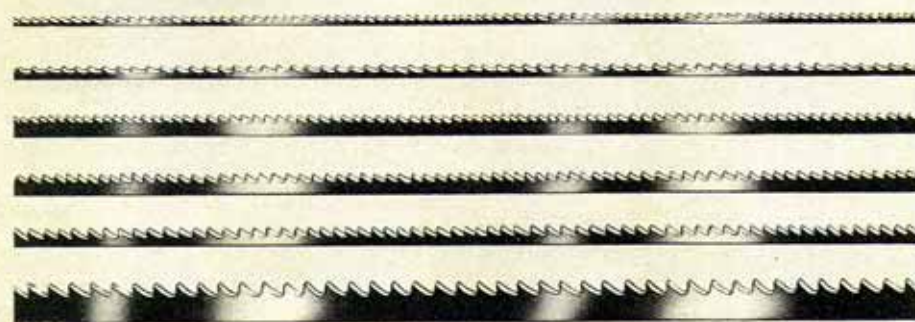

Jig, Fret, Coping Saw Blades

CRAFTSMAN. Special alloy "Super-Tuff" steel, heat treated and hardened for long life and fast easy cutting. 6 and 8 1/2-in. plain end blades can be snapped off to fit machine taking shorter plain end blades. Saber tooth blades may be used for heavy cutting as well as saber work.

For wood cutting, use: 9A2692, 9A2693, 9A2694, 9A2690
 For wood or metal, use: 9A2695, 9A2702, 9A2704, 9A2700
 9A2701, 9A2705, 9A2706, 9A2707
 9A2709, 9A2867
 For general application, use: 9A2866, 9A2869, 9A2712
 For wood and plastic, use: 9A2710
 For metal only, use: 9A2703

Catalog Number	Type End	Length inches	Teeth per inch	Thickness inch	Width inch	Blades in Pkg.	Shipping weight	Price Per Pkg.
9 A 2712	Pin	2 3/4	18	.010	.040	6	1 oz.	25c
9 A 2690	Pin	5	18	.010	.040	6	1 oz.	25c
9 A 2705	Pin	5	15	.020	.110	6	1 oz.	25c
9 A 2704	Pin	5	10	.020	.110	6	1 oz.	25c
9 A 2703	Plain	6	32	.020	.070	6	1 oz.	25c
9 A 2692	Plain	6	22	.008	.035	8	1 oz.	25c
9 A 2709	Plain	6	20	.020	.110	6	1 oz.	25c
9 A 2693	Plain	6	18	.010	.045	8	1 oz.	25c
9 A 2701	Plain	6	16	.020	.110	6	1 oz.	25c
9 A 2702	Plain	6	16	.014	.078	6	1 oz.	25c
9 A 2694	Plain	6	16	.010	.055	8	1 oz.	25c
9 A 2695	Plain	6	14	.010	.070	8	1 oz.	25c
9 A 2700	Plain	6	10	.020	.110	6	1 oz.	25c
9 A 2710	Plain	6	7	.020	.110	6	1 oz.	25c
9 A 2867	Saber	6	20	.028	.250	3	1 oz.	25c
9 A 2869	Saber	6	10	.028	.1875	3	1 oz.	25c
9 A 2866	Saber	6	7	.028	.250	3	1 oz.	25c
9 A 2707	Plain	8 1/2	15	.020	.110	6	1 oz.	25c
9 A 2706	Plain	8 1/2	10	.020	.110	6	1 oz.	25c

CRAFTSMAN
MILLIUM

Band Saw Blades

Finest quality saw steel. Every blade properly set and filed for recommended use. Shipping weight each, 7 ounces. Please state width wanted.

Low as **89c**

9 A 2660—For wood. 56 1/2 in. long. 3/4 or 1/2-in. width. Each 89c
 9 A 2336—For wood. Skip tooth. 58 in. long. 3/16, 1/4 or 3/8-in. width. 98c
 9 A 2663—For wood. Skip tooth. 62 in. long. 3/16, 1/4 or 3/8-in. width. 98c
 9 A 2665—For wood. 63 in. long. 1/4, 3/8 or 1/2-in. width. 89c
 9 A 2657—For wood. 78 in. long. 1/4, 3/8 or 1/2-in. width. 98c
 9 A 2623—For wood. 80 in. long. 1/4, 3/8 or 1/2-in. width. 98c
 9 A 2668—For brass and non-ferrous metal. 78 in. long. 3/4-in. width. 98c
 9 A 2624—For brass and non-ferrous metal. 80 in. long. 3/4-in. width. \$1.05
 9 A 2625—For steel 80 inches long; 3/4-in. width. \$1.55

Special length Band Saw Blades

9 A 2669F—Not brazed. Blades brazed for 45c each, in addition to prices below. State length and width wanted and if you want blades brazed. Shipped from factory in Chicago.

Width	Shpg. wt.	Per foot
3/8 inch	1 ounce	13c
1/2 inch	1 ounce	13c
5/8 inch	1 ounce	13c
3/4 inch	1 ounce	14c
7/8 inch	1 ounce	17c
1 inch	1 ounce	19c
1 1/8 inch	2 ounces	21c
1 1/4 inches	2 ounces	22c
1 3/8 inches	3 ounces	29c
1 1/2 inches	3 ounces	35c

CRAFTSMAN "100"
REG. U. S. PAT. OFF.

12-inch Band Saw

Cuts wood 6 inches thick

Here's a mighty essential saw for all woodworking shops! You're able to saw curves in lumber up to 6 inches thick and to the center of a 24-inch circle with this CRAFTSMAN heavy duty Band Saw. This extra large, extra safe saw is designed to meet your toughest production problems. When equipped with special blades, it can be used for sawing asbestos, bakelite, paper, insulation, fiberboard, sheet metal, etc. When a rip fence (described below) is attached to the table, this saw is ideal for ripping lumber.

Large cutting capacity. The $14\frac{3}{16} \times 12\frac{3}{4}$ -inch table tilts and locks to any angle up to 45° . . . adjusts with accurate tilt angle indicator. With the non-tilting extension the table size is $18\frac{3}{8} \times 14\frac{3}{16}$ inches. Regular table made of smooth ground heavy ribbed cast iron. In center of table, around the saw blade, is a soft aluminum throat plate that prevents damage to blade in case of breakage.

Extra safe. Notice the fully enclosed design! It's sleek, streamlined and safe. Safe because practically all the working parts, except the actual cutting section of the blade, are completely enclosed in a sturdy steel frame or casing. No chance of injury to the operator if the blade should accidentally break! It's inside the casing where it can't fly out. This is one of the safest band saws ever built.

Rugged superior construction. The two rubber-tired cast iron wheels used in this CRAFTSMAN Band Saw are much heavier than conventional steel or die cast wheels found in other saws. The lower wheel is the driver and is connected by a belt to the motor. This feature and the extra weight gives a flywheel effect for exceptionally smooth operation even on deep cuts. The upper wheel raises and tilts on sturdy mounting to adjust the blade tracking and tension. Each wheel runs on two sets of ball bearings.

\$74⁵⁰ CASH
Without Motor
\$750 DOWN . . .
ON TERMS

Accurate cutting. The saw guides, one above and one below the table, hold the blade firmly but gently in place . . . keep the blade from twisting and wobbling . . . enables you to make true, accurate cuts. The guides are made of hardened steel and have oil-impregnated adjustable bronze blocks. Ball bearing thrust wheels.

SPECIFICATIONS:

- Depth of throat, maximum $12\frac{3}{4}$ inches
- Depth of cut, maximum $6\frac{3}{4}$ inches
- Table size $12\frac{3}{8} \times 14\frac{3}{16}$ inches
- Table size with auxiliary table (included) $18\frac{3}{8} \times 14\frac{3}{16}$ inches
- Length of blade 80 inches
- Width of blade (one included) $\frac{3}{4}$ -inch
- Blade capacity $\frac{3}{8}$ to $\frac{1}{2}$ inch
- Bearings Four sets ball bearings
- Size of each wheel 12 inches
- Machine pulley (included) 5 inches
- Motor pulley (not included) 2 inches
- Motor recommended minimum $\frac{3}{4}$ H.P. 1750 R.P.M.
- Recommended speed: Revolutions per minute approx. 690
- Feet per minute 2200
- Mounting dimensions $5\frac{3}{4} \times 13\frac{3}{8}$ inches
- Over-all dimensions: Height 35 inches; width $24\frac{1}{16}$ inches; depth $14\frac{3}{16}$ inches.

The strong, rigid steel column and heavy cast iron castings form a super strong frame. All parts of the frame are locked in perfect alignment . . . helps eliminate vibration and insure smoothness of operation. Shipping weight 104 pounds.

- 99 AM 2337—CRAFTSMAN 12-inch Band Saw without motor \$74.50
- 99 AM 2379—CRAFTSMAN 12-inch Band Saw with $\frac{3}{4}$ H.P. 1750 R.P.M. ball bearing split phase, 110-120-volt, 60-cycle A.C. motor. 2-in. motor pulley, $\frac{1}{2} \times 38$ -in. V-Belt. Shpg. wt. 134 lbs. \$93.00

Rip Fence for above Band Saw

Here's a very handy band saw accessory for use when making straight cuts on thin pieces of lumber. The best results can be obtained if you use it with a $\frac{3}{8}$ -inch blade. $\frac{3}{8}$ -inch blades have little tendency to be deflected by heavy grain in wood. Equipped with locks at front and rear for better alignment. Comes complete with all the necessary fittings. (Illustrated at left.) Shipping weight 5 pounds.

- 9 A 2343—Rip Fence for 99 AM 2337 Band Saw above \$5.00

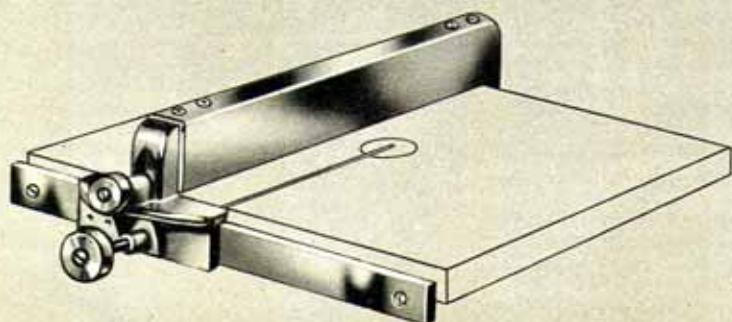



\$54.95
CASH
\$5.50 DOWN . . .
ON TERMS

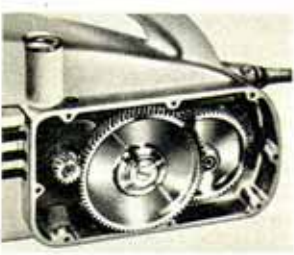
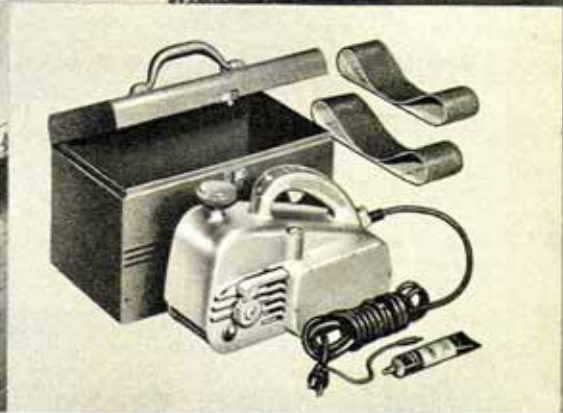

In the view at the left, you see the spiral cut steel gears used in CRAFTSMAN Portable Belt Sander. The exclusive triple-drum construction makes possible a direct gear reduction from the motor to the drive shaft. No right-angle drive requiring a complicated arrangement of worm or bevel gears is needed.

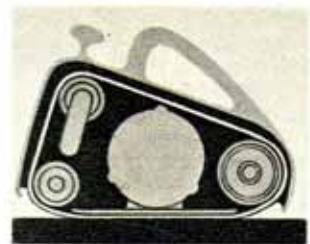

Notice, in the drawing at the left, how the three-drum construction makes possible more efficient construction . . . modern streamlined design. The sturdy motor is mounted in the center inside the housing for greater efficiency, better balance and easier handling. Permits use of a longer belt which gives you greater belt life.

CRAFTSMAN Portable Belt Sander

Exclusive 3-drum construction . . . Heavy duty G. E. Universal Motor

Do your sanding the modern electric sander way! Save time . . . take this CRAFTSMAN Portable Belt Sander to the job. You'll be amazed . . . it's so light weight and easy to handle. The frame and housing are made of strong die cast aluminum . . . motor is mounted in the center . . . completely protected. Here is the ideal sander for craftsmen, boat builders, cabinet makers, pattern makers, etc.

3-drum design. The great development in sander construction that is far superior to conventional 2-drum construction. It permits direct spiral gear reduction to drive shaft. No right angle drives or complex worm or bevel gearing. It also makes possible the modern functional design . . . gives minimum clearance on one side and front for getting into tight places as well as close to walls and corners.

Superior sanding surface. The 26 $\frac{3}{4}$ x3 inch sanding belt is longer and wider than belts used on conventional 2 drum sanders of the same general size.

This sander produces a new, clean, smooth surface swiftly. And it means less wear and longer belt life with fewer belt changes. Metal shoe, on bottom of sander, keeps belt in even contact with work.

Smooth, easy operation. The convenient quick-change belt release lever is located on outside of housing. Just flip it and belt is loose . . . ready to be removed. All you do is replace belt, flip lever again and you're set to go back to work. All three drums are equipped with dust-protected, self-lubricating bronze bearings . . . extra large oil reserves. Built-in fan air cools the motor.

- SPECIFICATIONS:**
- Belt size: width 3 inches
 - length 26 $\frac{3}{4}$ inches
 - Bearings: motor precision ball drums self lubricating bronze
 - Free speed of belt 1200 ft. per minute
 - Gears spiral cut steel

- Belt release quick change, cam operated
 - Motor G.E. universal, 110-120 volt AC-DC
 - Switch safety trigger type; non-locking
 - Over-all dimensions: Height 8 inches; length 11 $\frac{1}{4}$ inches; width 5 inches
- Powerful G.E. universal ball-bearing motor develops $\frac{3}{4}$ H. P. maximum; has heat and abrasion-resistant Formex insulation that guards against motor "burnout." This sander is safe too. Will not run unless operator holds trigger switch in "on" position. Comes complete with 10 feet of 3-wire cord, plug, 3 assorted belts and heavy duty all-steel carrying case.

99 A 02230—Shipping weight 18 lbs. **\$54.95**
Replacement Belding Belts. Made of silicon carbide abrasive on cloth, 3x26 $\frac{3}{4}$ inches. Your choice of four grit sizes: 00 (extra fine), 0 (fine), 1 (medium) and 2 (coarse). Please state grit size wanted.
9 A 2231—Shpg. wt. per belt 4 oz. **32c**

See inside front cover for Sears Easy Terms

\$42.50
CASH
\$4.50 DOWN . . .
ON TERMS



With box and accessories



Really a work saver! Perfect for polishing your car, removing rust, and similar jobs



Flexible sanding discs are just the thing for sanding curved or irregular work surfaces



Works in any position. Use for resurfacing floors, woodwork, ceilings, furniture, etc.



Takes the hard work out of polishing furniture, floors, linoleum, etc. Saves time in the home or shop

CRAFTSMAN Disc Sander, Buffer, Polisher

REG. U.S. PAT. OFF.

Will actually do the job 10 times faster than by hand

Painters, cabinet makers, metal workers, auto refinishers, hobby crafters and housewives . . . you'll want this CRAFTSMAN Disc Sander for your work. Everyone who does sanding or polishing will want it. It's ideal for work on autos, boats, furniture, floors, wood or metal . . . and for all types of general maintenance work. You'll actually be able to do your sanding, polishing and buffing jobs *10 times faster than by hand*. Produces a better job without all the hard work.

Easy to operate. Just think . . . No rubbing! No pressing! No more aching arms and backs! You'll be amazed at how easy this disc sander is to operate and how swiftly it does your work. Simply plug it in . . . snap the handy trigger switch . . . and go to work. The machine does the work for you almost like magic. All you do is guide it.

Lightweight. It weighs only 6 pounds. So light and well designed that it's as easy to handle as an ordinary flatiron. Women can use it to zip through those

ordinarily tiresome polishing tasks in the home.

Sturdy construction. Frame is made of strong die-cast aluminum alloy . . . makes this disc sander light and easy to operate yet withstands many long hours of steady use. Equipped with a heavy duty 110-120-volt General Electric Universal A.C.-D.C. motor develops $\frac{3}{4}$ H.P. maximum. Formex insulation . . . giving long motor life. The motor, mounted directly over disc, provides maximum power and perfect balance.

SPECIFICATIONS:

- Disc size, diameter 6 inches
- Over-all height, with disc 7 inches
- Bearings Precision ball
- Gears Helical spur
- Free speed of disc 1600 R.P.M.
- Switch Trigger type; Non-locking
- Motor G.E. Universal 110-120 volt, 25-60 cycle, A.C.-D.C.
- Length of cord 10 feet

Handy knob and switch. Convenient, easy to control trigger switch is located on hand-fitting handle. Switch is non-locking. Large plastic knob for two hand control can be mounted on either side.

Accessories included. Comes complete with 10-ft. 3-wire rubber covered cord and plug, 6-inch flexible rubber sanding disc, 7-inch lamb's wool buffing bonnet, 6 assorted sanding discs, socket wrench for attaching discs and steel case to hold sander and accessories. Sander may be used on wood, metal, plastic, concrete, stone, wallboard etc. either flat or curved surfaces. Shipping weight 12 pounds.
99 A 02561—CRAFTSMAN Disc Sander **\$42.50**

Sanding discs for above sander. Made of silicon carbide abrasive. Choice of four grits; 00 (extra fine), 0 (fine), 1 (medium) or 2 $\frac{1}{2}$ (coarse). Package of 6 of any one grit. Diameter of discs 6 inches.
9 A 2562—State grit wanted. Shpg. wt. 7 oz. **39c**

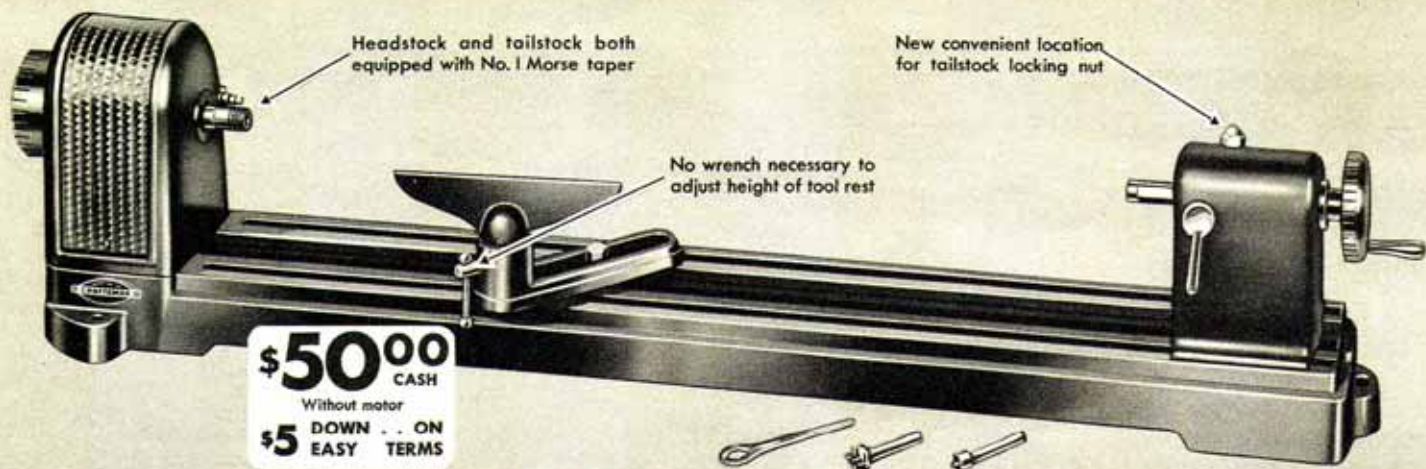

CRAFTSMAN "100" Ball-bearing Lathe

Ball Bearings in Headstock—Threaded Spindle

9-inch swing . . . 30 inches between centers . . . 46 $\frac{3}{4}$ -inch bed. By far our finest wood-turning lathe. A big, production-type lathe—with extra heavy duty construction throughout. A perfect tool for the master craftsman. Because of its excellence in every detail, it is sure to gain an important place in professional woodworking and pattern shops all over America.

Extra heavy cast semi-steel construction reduces vibration. Even under heavy cuts or high speeds this lathe operates with exceptional smoothness and accuracy. Bed is sturdy, rigid and well braced. Three-point mounting helps eliminate twist and strain. All parts are accurately machined.

Two precision ball bearings—oiled for life—and one ball thrust bearing in headstock. Provide almost limitless service. Protected against grit and dirt. Assures longer life—greater accuracy in operation. Ball thrust bearing absorbs end thrust.

No. 1 Morse taper in both headstock and tailstock. Easy to use with work arbor, drill chuck, etc. Removable cover on outboard end of $\frac{3}{4}$ -inchx16 left hand thread headstock spindle permits outboard turning of larger diameter work without reversing motor. Has indexing pin for use in fluting. May be driven from rear or below. Has attractive rust-resisting gray enamel finish.

Comes complete with tool rest, spur and cup centers, wrench (same wrench is used for both tool-rest slide and tailstock), 4-inch 4-step motor pulley, $\frac{3}{4}$ x44 in. V-belt. Chromium plated hand wheels and headstock spindle cover.

SPECIFICATIONS:

- Spindle $\frac{3}{4}$ -inchx16 right hand thread; No. 1 Morse female taper
 - Spindle speeds Four: 875, 1350, 2250 and 3450 R.P.M.
 - Tailstock taper No. 1 Morse, female
 - Tailstock ram travel 2 $\frac{3}{4}$ inches
 - Machine pulley (included) 4-in. 4-step V type cone
 - Motor pulley recommended (not included) 4-in. 4-step V type cone
 - Motor recommended (minimum) $\frac{1}{2}$ H.P.; 1750 R.P.M.
 - Mounting dimensions (hole centers) 7 $\frac{1}{16}$ x43 $\frac{3}{8}$ in.
 - Over-all dimensions height 10 $\frac{3}{4}$ in.; width 8 $\frac{3}{4}$ in.; length 50 $\frac{1}{2}$ in.
- 99 AM 2307—Without motor. Shipping weight 82 lbs. \$50.00
 99 AM 2396—With $\frac{1}{2}$ H. P. split phase 1750 R.P.M. 110-120-volt 60-cycle A.C. ball bearing motor and 4-inch, 4-step motor pulley. Shpg. wt. 112 lbs. \$68.50

CENTERS

For Centers to fit the CRAFTSMAN Lathe above see page 25

CHUCKS

For Chucks to fit the CRAFTSMAN Lathe above see page 25

ARBORS

For Arbors to fit the CRAFTSMAN Lathe above see page 25

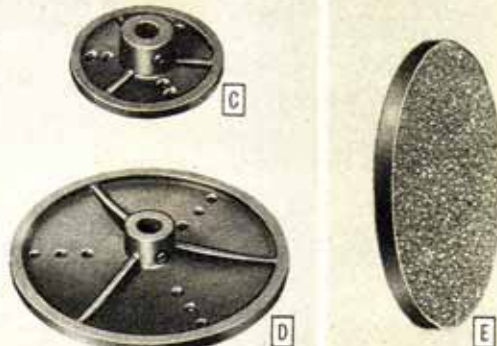
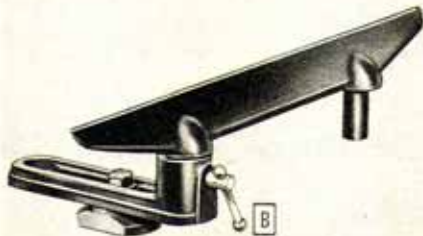
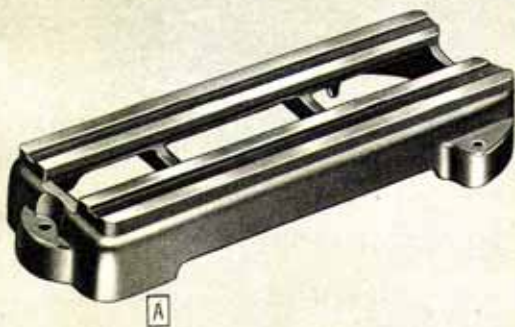

Lathe Bed Extension

A Exceptionally handy accessory for your lathe when doing extra long turning such as table legs, bed posts, lamp standards, etc. It's 18 inches long. Increases the distance between centers to anything you require. Heavy cast semi-steel in one piece. It's ribbed and reinforced just like lathe bed. For CRAFTSMAN 99AM2307 lathe shown above or 2318. Shpg. wt. 20 lbs. 9 A 2488 \$9.75

\$975

Long Tool Rest

B A great convenience when making long turnings such as table legs, bed posts, lamp spindles, etc. Makes it unnecessary to shift the standard tool rest down the bed. It's extra long . . . a full 20-inches. Made of high quality cast semi-steel . . . well machined and nicely finished. Mounts rigidly on lathe bed. Readily adjusted for height. May be used on the CRAFTSMAN 9 AM 2307 lathe above or 2318. With one bed bracket. 9 A 2316—Shpg. wt. 10 lbs. . . \$5.40

\$540

High grade Face Plates

Make your lathe much more useful. High quality cast iron construction. Complete with setscrew. **\$210**
 9 A 2320
C For 99A02160 lathe shown on opposite page or any other lathe with $\frac{5}{8}$ -inch straight unthreaded spindle. 9 A 2320—4-inch diameter. Shpg. wt. 1 lb. 5 oz. . . . \$2.10
D For 2318 lathe or any other lathe with $\frac{3}{4}$ -inch straight unthreaded spindle. For inboard turning. 9 A 2324—4-in. diam. Shpg. wt. 2 lbs. \$2.10
 9 A 2325—8-in. diam. Shpg. wt. 2 lbs. 8 oz. 3.80
 For 99AM2307 lathe shown above or any other lathe with $\frac{3}{4}$ x16-thread spindle. Shipping weight 2 pounds. 9 A 2489—4-in. diam. For inboard turning. \$2.35
 9 A 2490—8-in. diam. For inboard turning. 4.10
 9 A 2492—8-in. diam. For outboard turning. 4.05
 3-inch diameter. (Not shown.) Complete with spurs, removable center and screw center. 9 A 2091—Shipping weight 1 pound 12 ounces. . . . \$1.95

Sanding Plates

E Carefully machined and balanced. Fitted with sandpaper. Cast iron construction. **\$395**
 8-in. diam. 9 A 2491
 For 99 AM 2307 lathe shown above or other $\frac{3}{4}$ -in.x16 right hand threaded spindles. 9 A 2491—8-inch diameter. Shipping wt. 2 lbs. 8 oz. \$3.95
 For 99 A 02160 lathe on opposite page or other $\frac{5}{8}$ -inch straight unthreaded spindles. 9 A 2341—8-inch diameter. Shpg. wt. 2 lbs. \$3.75
 For 2318 lathe or any lathe with $\frac{3}{4}$ -inch plain unthreaded spindle. 9 A 2308—8-inch diameter. Shpg. wt. 2 lbs. 8 oz. \$3.75

EASY TERMS

It's easy to buy the power tools you need in one order for only a small amount down if you use Easy Terms. See inside front cover.



CRAFTSMAN "40" Lathe . . new design, features

Only \$3 down will put this fine Wood Turning Lathe in your shop

8-inch swing . . . 24 inches between centers . . . 36 $\frac{3}{4}$ -inch bed. Famous CRAFTSMAN quality is built into every part of this rugged, well made lathe. Modern in every way . . . with many important post-war improvements in design and construction. We believe you will find it impossible to buy another lathe in this price range that matches this CRAFTSMAN Lathe for quality features, performance and capacity. It's a "must" in any well equipped work shop.

Heavy cast semi-steel construction for smooth, accurate operation. Entire bed is made in one piece, ribbed and reinforced to reduce vibration to a minimum. All parts are accurately machined. 3-point mounting helps eliminate twist and strain. Tailstock easily and quickly adjusted.

Two oilite self-lubricating bronze bearings and one ball thrust bearing in headstock. Oil well surrounds each bearing. This close, tight seal keeps spindle journals accurate—protects them against dirt and grit. Oil actually filters through bronze. Assures longer life and greater accuracy in operation. Ball thrust bearing absorbs spindle thrust to give smooth, accurate operation.

$\frac{3}{8}$ -inch straight unthreaded spindles in headstock and tailstock. Removable cover on outboard end of spindle makes it easy to turn large diameter work without

reversing the motor. May be driven from the rear or below. Comes complete with tool rest, spur and cup centers, wrench (for tool rest slide, tool rest, and tailstock lock) and 3-inch 3-step pulley. (V-belt not included.) Attractive rust-resisting gray enamel finish; handles and headstock spindle cover are cadmium plated.

SPECIFICATIONS:

- Spindle $\frac{3}{8}$ -inch straight unthreaded
- Spindle speeds Three: 1025, 1750 and 2985 R.P.M.
- Tailstock ram travel 1 $\frac{1}{4}$ inches
- Machine pulley (included) 3-inch 3-step V-type cone
- Motor pulley recommended (not included) 3-inch 3-step V-type cone
- Motor recommended (minimum) $\frac{3}{4}$ H.P. 1750 R.P.M.
- Mounting dimensions (hole centers) 33 $\frac{3}{4}$ x 6 in.
- Over-all dimensions Height 8 $\frac{1}{2}$ in.; width 7 in.; length 40 in.
- 99 A 02160—Without motor. Shipping weight 54 pounds. \$27.00
- 99 AM 2162—With $\frac{3}{4}$ H.P. split phase 110-120-volt 60-cycle A.C. 1750 R.P.M. ball bearing motor. 3-inch 3 step cone-type pulley, $\frac{3}{4}$ x36-inch "V"-belt. Shipping weight 84 pounds. \$46.00

CENTERS

For Centers to fit the CRAFTSMAN Wood Turning Lathe above—turn to page 25

CHUCKS

For Chucks to fit the CRAFTSMAN Wood Turning Lathe above—turn to page 25

ARBORS

For Arbors to fit the CRAFTSMAN Wood Turning Lathe above—turn to page 25

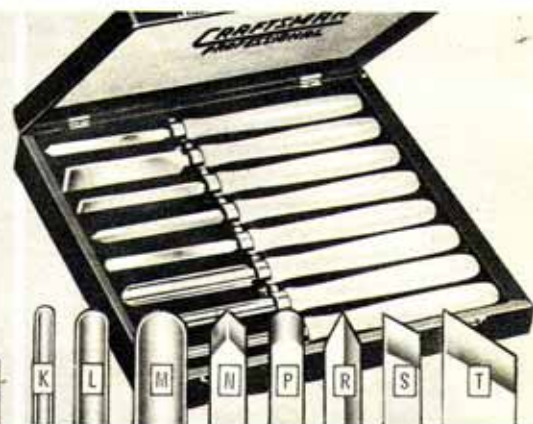
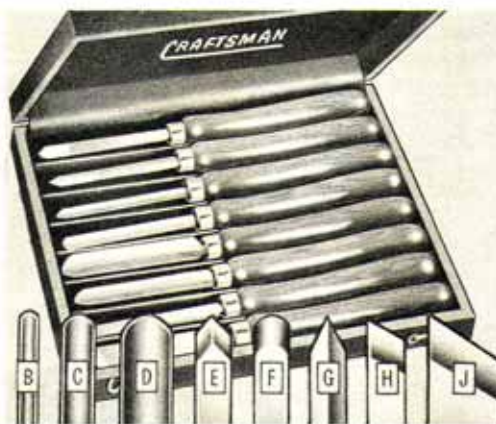
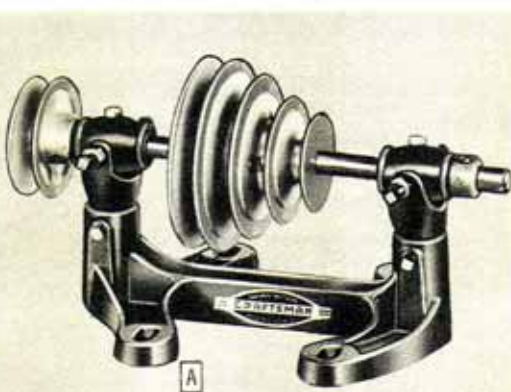

CRAFTSMAN Jack Shaft

A CRAFTSMAN Cone Pulley Jack Shaft. Used with matching cone pulley on machine. Provides broad speed variations on lathes, drill presses, jig saws, sanders, grinders, etc. Speed is varied in certain definite steps. It is most commonly used between the motor and tool being driven. With proper pulleys, the speed of the jack shaft itself may be varied from motor speed, thus raising or lowering the range of speeds which are available in the driven machine.

Has self-aligning, self-lubricating bronze bearings with oil reservoirs. Cast iron base. Shaft of durable cold rolled steel. Die-cast pulleys. For use with $\frac{3}{8}$ -inch V-belts. Shipping weight each 7 pounds 8 ounces.

9 A 2494—Please state size wanted.
With 4-inch 4-step pulley \$6.75
With 5-inch 4-step pulley 6.90

\$675
4-inch

CRAFTSMAN Turning Chisels

In these fine chisels, you get genuine CRAFTSMAN quality at moderate prices. All have brightly polished 4-inch steel blades, carefully tempered to take and hold a keen edge for fast, clean cutting. Expertly ground. 8-in. handles of smoothly finished hardwood, securely fastened to blades. Heavy ferrule. Average over-all length 13 inches. Shpg. wt. each 13 oz.

- \$130** 9 A 2850
- (B) 9 A 2850—Gouge, $\frac{1}{4}$ -inch wide \$1.30
 - (C) 9 A 2851—Gouge, $\frac{1}{2}$ -inch wide 1.40
 - (D) 9 A 2852—Gouge, $\frac{3}{4}$ -inch wide 1.55
 - (E) 9 A 2854—Spear Point Chisel, $\frac{3}{4}$ -in. wide 1.10
 - (F) 9 A 2856—Round Nose Chisel, $\frac{3}{4}$ -in. wide 1.15
 - (G) 9 A 2858—Parting Tool, $\frac{3}{4}$ -in. wide 1.35
 - (H) 9 A 2862—Skew Chisel, $\frac{3}{4}$ -in. wide 1.15
 - (J) 9 A 2863—Skew Chisel, 1-inch wide 1.35

9 A 2853—Complete set of 8 chisels listed above, in sturdy wood box covered with attractive artificial leather. Shipping weight 8 pounds 10 ounces. \$12.00

CRAFTSMAN heavy duty Chisels

The finest wood-turning chisels we have ever sold. Real professional quality. Forged "Super-Tuff" steel blades, about 6 inches long, heat treated to take and hold a super keen edge. Expertly ground. Blades are highly polished and beautifully finished. 10-inch maple handles; lustrous natural finish. Average length 16 $\frac{3}{4}$ in. Shpg. wt. each, 1 lb. 2 oz.

- \$230** 9 A 2877
- (K) 9 A 2877—Gouge, $\frac{1}{4}$ -inch wide \$2.30
 - (L) 9 A 2878—Gouge, $\frac{1}{2}$ -inch wide 2.40
 - (M) 9 A 2879—Gouge, $\frac{3}{4}$ -inch wide 2.60
 - (N) 9 A 2890—Spear Point Chisel, $\frac{3}{4}$ -inch wide 1.65
 - (P) 9 A 2891—Round Nose Chisel, $\frac{3}{4}$ -inch wide 1.65
 - (R) 9 A 2893—Parting Tool, $\frac{3}{4}$ -inch wide 2.10
 - (S) 9 A 2894—Skew Chisel, $\frac{3}{4}$ -inch wide 1.65
 - (T) 9 A 2895—Skew Chisel, 1-inch wide 1.85

9 A 2898—Set of 8 professional chisels listed above, in heavy wood box covered with attractive artificial leather. Shipping weight 11 lbs. \$17.95

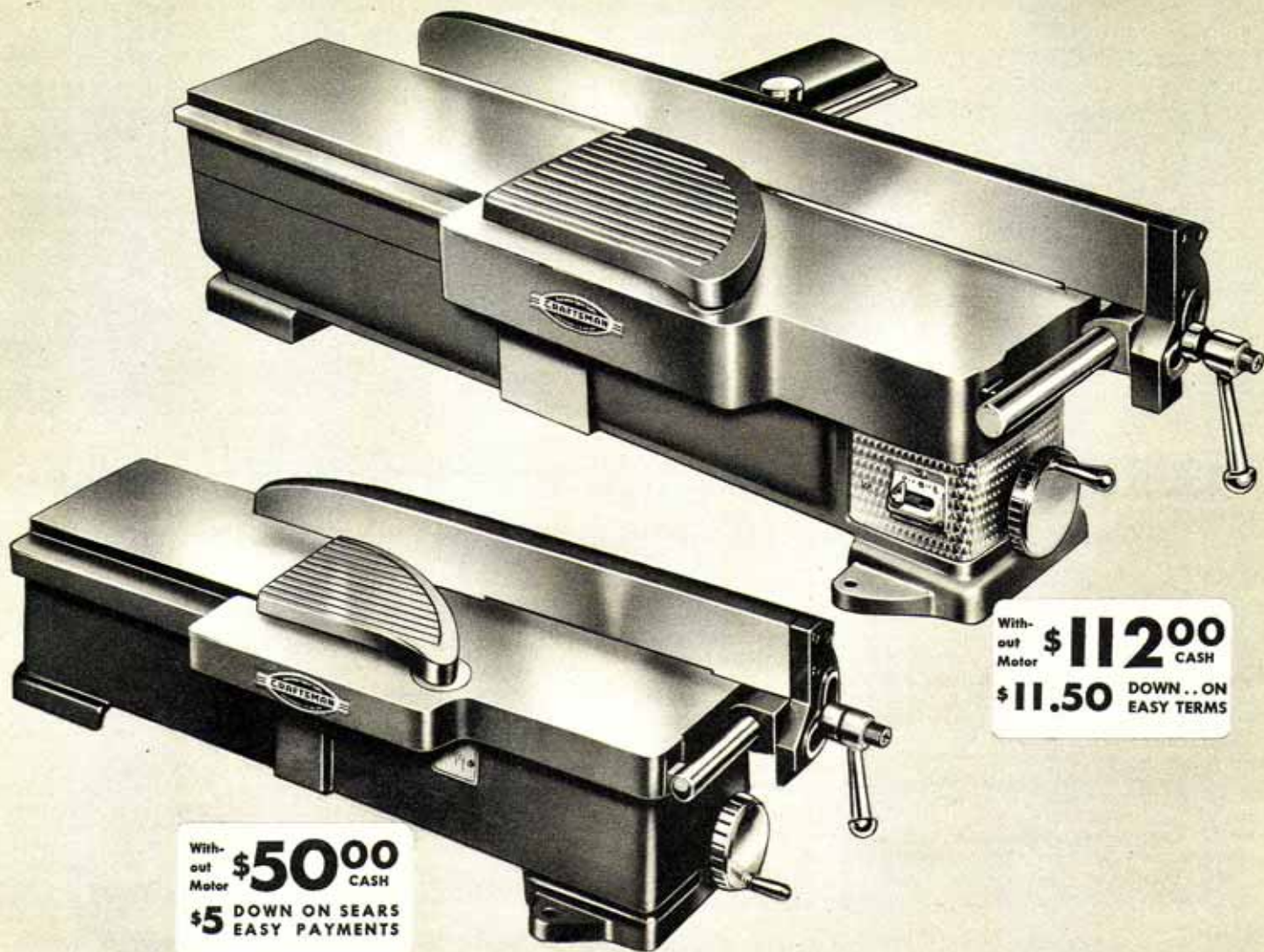

With-
out
Motor **\$112.00** CASH
\$11.50 DOWN... ON
EASY TERMS

With-
out
Motor **\$50.00** CASH
\$5 DOWN ON SEARS
EASY PAYMENTS

CRAFTSMAN Jointer-Planers . . . accurate and safe

CRAFTSMAN "80" ball bearing type

The ideal jointer-planer for small woodworking shops, school shops and home workshops. The three $4\frac{3}{4}$ inch high speed steel knives in the $4\frac{1}{4}$ -inch cutter head are securely locked in. Retain sharp, easy-cutting qualities.

Front and rear table are precision ground cast iron and operate on accurately machined ways to insure perfect alignment. $19\frac{3}{8}$ -inch fence tilts 45 degrees either way . . . locks in position. Rugged one-piece cast iron base, with three-point mounting, eliminates twist or strain, gives rigid support.

Quick-acting guard gives positive protection . . . readily removable for making rabbeting cuts. Accurate gauge indicates depth of cut and angle of tilt with rip fence. Ball bearings sealed against dirt and lubricated for life.

SPECIFICATIONS:

- Width of cut. $4\frac{3}{4}$ inches
 - Depth of cut. $\frac{3}{8}$ inch
 - Rabbet depth. $\frac{3}{8}$ inch
 - Bearings. 2 sets sealed precision ball
 - Cutter knives. 3 high speed steel, $4\frac{3}{4} \times \frac{1}{2} \times \frac{3}{8}$ inches
 - Length of front table. $11\frac{3}{4} \times 6\frac{3}{8}$ inches
 - Length of rear table. $11\frac{3}{4} \times 6\frac{3}{8}$ inches
 - Length of fence. $19\frac{3}{8}$ inches
 - Spindle diameter. $\frac{1}{2}$ inch
 - Recommended speed, approximately. 4500 R.P.M.
 - Motor recommended, minimum. $\frac{1}{2}$ H.P. 1750 R.P.M.
 - Machine pulley (included). 2 inch single "V" groove
 - Motor pulley (not included). 5 inch single "V" groove
 - Mounting dimensions. $7\frac{3}{4} \times 21\frac{3}{4}$ inches
 - Overall dimensions: Height 8 inches; width $9\frac{3}{4}$ inches; length $29\frac{1}{8}$ inches
- 99 AM 2334—CRAFTSMAN Jointer without motor. Shpg. wt. 95 lbs. **\$50.00**
 99 AM 2340—CRAFTSMAN Jointer with $\frac{1}{2}$ H.P. 1750 R.P.M. ball bearing split phase motor for 110-120-volt 60 cycle AC. 5-inch motor pulley, $\frac{3}{8} \times 40$ -inch V-belt. Shipping weight 95 lbs. **\$69.00**

$4\frac{3}{4}$ -inch Jointer Replacement Knives. High speed steel blades; ground to a keen edge. Set of three for above jointers or for Nos. 2287 and 2290.
 9 A 2291—Shipping weight 7 ounces. Set **\$3.35**

CRAFTSMAN "100" ball bearing type

Heavy duty jointer-planer gives you greater accuracy, smoother operation and greater safety. 6-inch solid steel cutterhead has 3 high speed steel knives.

Sturdy construction. Extra long precision ground cast iron table. Three-point suspension mounting of rear table aligns it perfectly with front table. Front table mounted on double set of widely spaced ways. One-piece base is rugged cast iron for rigid support. Three-point-of-contact mounting eliminates twist.

Quick-acting spring-loaded guard gives complete protection. It never needs to be removed while machine is running. Guard can be removed in one motion for rabbeting cuts. Belt and pulley fully enclosed by guard for safety. $31\frac{3}{16}$ -inch fence tilts up to 45° in either direction . . . locks in place.

SPECIFICATIONS:

- Width of cut. $6\frac{3}{8}$ inches
 - Depth of cut. $\frac{3}{8}$ inch
 - Rabbet depth. $\frac{3}{8}$ inch
 - Bearings. 2 sets sealed precision ball
 - Cutter knives. 3 high speed steel, $6\frac{3}{8} \times \frac{1}{2} \times \frac{3}{8}$ inches
 - Length of front table. $16\frac{3}{16} \times 7\frac{3}{8}$ inches
 - Length of rear table. $17\frac{3}{8} \times 7\frac{3}{8}$ inches
 - Length of fence. $31\frac{3}{16}$ inches
 - Spindle diameter. $\frac{5}{8}$ inch
 - Recommended speed, approximately. 4500 R.P.M.
 - Motor recommended, minimum. $\frac{3}{4}$ H.P. 3450 R.P.M.
 - Machine pulley (included). 2 inch single "V" groove
 - Motor pulley (not included). $2\frac{1}{2}$ inch single "V" groove
 - Mounting dimensions. $8\frac{3}{8} \times 32\frac{3}{4}$ inches
 - Over-all dimensions: Height $11\frac{3}{8}$ inches; width 20 inches; length $42\frac{3}{8}$ inches
- 99 AM 2390—CRAFTSMAN Jointer without motor. Shpg. wt. 151 lbs. **\$112.00**
 99 AM 2391—CRAFTSMAN Jointer with $\frac{3}{4}$ H.P. 3450 R.P.M. ball bearing capacitor motor for 110-120-volt 60 cycle A.C. $2\frac{1}{2}$ -inch motor pulley, $\frac{3}{8} \times 42$ -inch V-belt. Shipping weight 188 lbs. **\$143.00**

$6\frac{3}{8}$ -inch Jointer Replacement Knives. Made of high speed steel; expertly ground. Set of three for above jointer and for thickness planer No. 2370.
 9 A 2293—Shipping weight 10 ounces. **\$4.10**

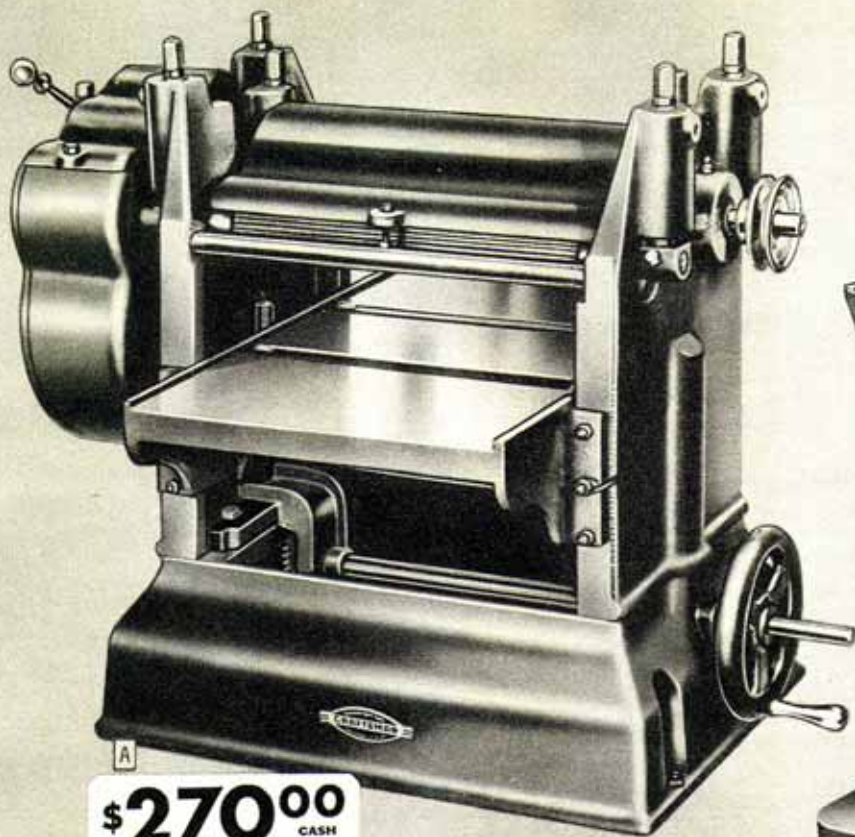

\$270⁰⁰ CASH
Without Motor
\$27 DOWN... ON SEARS
EASY PAYMENTS



\$6150 CASH
Without Motor
\$6.50 DOWN



\$7000 CASH
Without Motor
\$7 DOWN...

CRAFTSMAN Thickness Planers—Shaper

CRAFTSMAN Power Feed Planer

A CRAFTSMAN "100" heavy duty thickness planer... rugged and sturdy to withstand big daily production work. Extremely accurate cutting... holds cut to within a few thousandths of an inch... extra large diameter cutter with 3 knives and fast smooth power feed.

Extra large capacity. Planes lumber up to 12 in. wide and 4 in. thick... as short as 6 in. and as thin as $\frac{1}{16}$ in. Maximum depth of single cut $\frac{1}{32}$ in.

Solid, massive construction. Ribbed table fitted to massive one-piece cast iron frame by precision ways. Table quickly raised and lowered by handwheel.

Safety type cutter head. $3\frac{1}{2}$ -in. diameter. Machined from solid bar steel and fitted with 3 high speed steel knives. Chip breaker and pressure bar hold lumber firmly to bed. Solid steel feed rolls grip lumber and feed at rate of 17 lineal feet per minute.

SPECIFICATIONS:

- Depth of cut, maximum... $\frac{1}{32}$ inch
- Width of cut, maximum... 12 inches
- Table size... 12x20 inches
- Size of cutter head... $3\frac{1}{2}$ inches
- Knives... three; size $12 \times \frac{3}{16} \times \frac{1}{8}$ inches
- Bearings... 2 sets precision ball
- Power feed rate... 17 lineal feet per minute
- Machine pulley (included)... 3 inches
- Motor pulley (not included)... $6\frac{1}{2}$ inches
- Motor recommended (variable)..... $\frac{3}{4}$ to 2 H.P.; 1750 R.P.M.
- Recommended cutter head speed, approximately... 4200 R.P.M.
- Mounting dimensions... $8\frac{3}{4} \times 18\frac{3}{4}$ inches
- Over-all dimensions: height 23 in.; width 33 in.; depth 20 in.
- 99 AM 2349—Without motor. Shpg. wt. 300 lbs. **\$270.00**

CRAFTSMAN Hand Feed Planer

B Now you can salvage old material... finish rough sawed lumber... reclaim marred or painted wood... make flat stock out of warped boards, etc... all with this CRAFTSMAN "100" thickness planer.

Large capacity. Planes material up to 6 in. wide and 2 in. thick... as small as 4 in. long and $\frac{1}{8}$ in. thick. Open side design allows you to plane 12-in. boards. Depth of cut adjusted by convenient hand wheel. Gives accurate operation... holds cut to few thousandths of an inch.

Rugged long-life construction. Ribbed cast iron table and frame. Ways milled into one casting. Hand feed construction. Chip breaker and pressure bar guard head.

SPECIFICATIONS:

- Depth of cut, maximum... $\frac{1}{32}$ inch
- Width of cut, maximum... 6 inches
- Table size... $6\frac{1}{16} \times 19\frac{1}{16}$ inches
- Size of cutter head... $2\frac{1}{2}$ inches diameter
- Knives... three; size $6\frac{1}{2} \times \frac{3}{16} \times \frac{1}{8}$ inches
- Bearings... 2 sets precision ball
- Machine pulley (included)... 2 inch "V" groove
- Motor pulley (not included)... $2\frac{3}{4}$ inch "V" groove
- Motor recommended (min.)... $\frac{1}{2}$ H.P.; 3450 R.P.M.
- Mounting dimensions... 8x10 inches
- Over-all dimensions; height $15\frac{1}{2}$ inches; width $15\frac{3}{4}$ inches; length $19\frac{1}{8}$ inches.
- 99 AM 2370—Without motor. Shpg. wt. 84 lbs. **\$61.50**
- 99 AM 2371—With $\frac{1}{2}$ H.P. 3450 R.P.M. ball bearing capacitor motor for 110-120-volt 60-cycle A.C. $2\frac{3}{4}$ -in. machine pulley, $\frac{1}{2}$ x58-in. V belt.
- Shipping weight 120 pounds... **\$92.50**
- 9 A 2293—Set of 3 extra knives for above planer.
- Shipping weight 10 ounces... **\$4.10**

CRAFTSMAN Shaper

C One of the finest tools of its kind... sturdy, accurate and dependable. Built for high speed light duty production work. Cuts smoothly and rapidly at all possible angles to the grain of the wood. Ideal for shop and light commercial applications.

Extra large heavy duty table. 21x15 inches. Adjustable in height. Bevel gears and screw mechanism moves table up and down on a tubular steel column. Scale shows depth of cut. Fence is adjustable with one side movable in or out for planing operations.

Fixed spindle construction. Spindle and bearing assembly solidly mounted in frame for smooth, vibrationless operation. Tapered spindle permits use of wide variety of cutters. Cutters prevented from coming loose by keyway in shaft with keyed washer.

Built-in motor mount; spring hold-downs included.

SPECIFICATIONS:

- Cutter height... 13 $\frac{1}{2}$ inches
- Cutter bore... $\frac{1}{2}$ inch
- Spindle bearings... 2 sets ball bearings
- Table size... 21x15 inches
- Table height (variable)... 10 $\frac{1}{4}$ to 12 $\frac{3}{4}$ inches
- Miter gauge slot... $\frac{3}{4}$ in. wide; $\frac{1}{2}$ in. deep.
- Right fence face adjustable... up to $\frac{1}{2}$ inch
- Spindle... $\frac{1}{2}$ -in.; $\frac{1}{2}$ x24 thread
- Spindle speed, recommended... 8270 R.P.M.
- Machine pulley (included)... 3 $\frac{1}{2}$ inches
- Motor pulley (included) 4-inch diam.; $\frac{1}{2}$ -in. bore
- V-belt (included)... $\frac{1}{2}$ in. wide; 31 in. long
- Motor recommended (min.)... $\frac{1}{2}$ H.P., 3450 R.P.M.
- Mounting dimensions... 10 $\frac{1}{2}$ x9 $\frac{1}{2}$ inches
- Over-all dimensions: height 18 $\frac{3}{4}$ in.; width 16 in.; depth (without motor) 27 in.
- 99 AM 2381—Without motor. Shpg. wt. 116 lbs. **\$70.00**

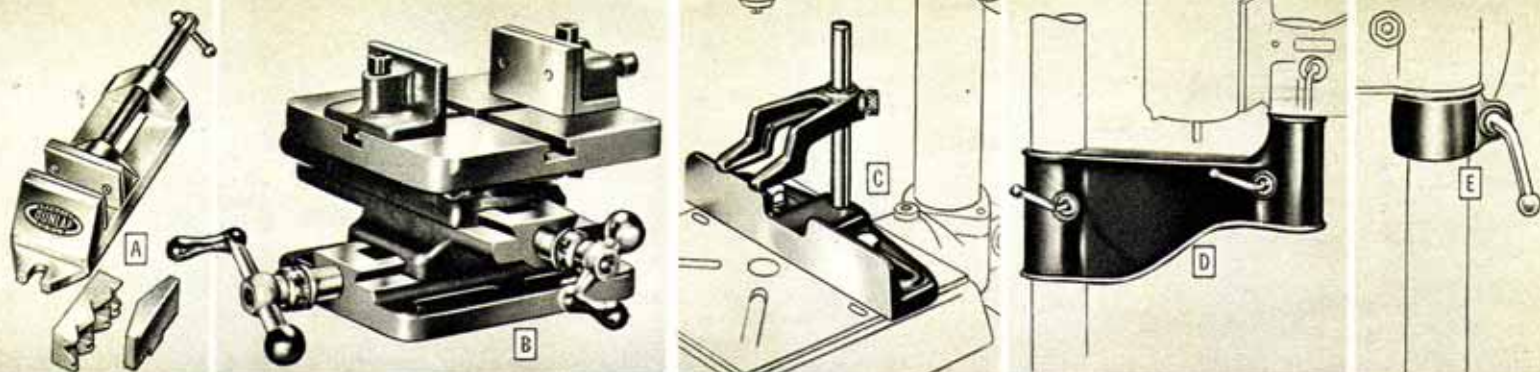

Fine quality, useful drill press accessories . . .

Drill Press Vice

A Increases accuracy by holding work firmly in position while it is being drilled or worked on. Increases the range in size of work you can handle. Makes working with small pieces more convenient.

Strong, accurately cut steel screw; knurled end; sliding handle. Cast of non-ferrous metal. 2 3/4-inch jaws with steel faces; open 3 inches. Complete with 2 extra cast iron jaws: one for round or irregular work and one for tapered pieces. Overall length of vise 10 1/2 inches. Shipping weight 4 pounds.

9 A 2436 \$3.50

CRAFTSMAN Drill Press Milling Vise

B Use this drill press milling vise to increase the usefulness of your drill press! This versatile accessory enables you to handle all types of accurate drilling, layout and spacing work—straight lines, radial and circular work; also light milling. Can be used with shaper, lathe or grinder for jobs in which accurate feeds in one or two directions are required.

Bolts on drill press table. The work is locked on the table between two adjustable jaws. By use of the two cross feed controls, work may be moved to any desired horizontal position. Base is graduated through 180 degrees so vise table may be rotated to any angle and set accurately. Table is 7x7 inches. Travel on both cross feeds is 6 inches. Capacity of vise 3 1/2 inches. Husky jaws are 3 inches wide; 1 3/4 inches high. Dovetailed ways assure smooth, accurate operation at all times. Complete with wrench.

99 A 02432—Shipping weight 18 lbs. \$36.50

\$36.50
CASH
\$4.00 DOWN

Hold-down Guide

C CRAFTSMAN. Made to fit almost any drill press table. Indispensable in mortising or repetitive drilling. Fingers on hold-down prevent work from being lifted when chisel or drill is raised. Easily adjustable for thick or thin materials. Fence keeps work lined up. Attachment bolts to drill press table; may be adjusted forward or backward simply by loosening bolts. Fence section can also be used without hold-down to serve as guide in routing, inlay work, repetitive drilling and similar operations. Durable heavy cast iron construction. Shipping weight 6 lbs. 6 oz.

9 A 2457 \$4.95

Drill Press Radial Arm

D Increases to 24 inches the distance from main column to chuck. Enables you to drill to center of a 48-inch circle. Can be swung to almost any horizontal position. When used in conjunction with column collar, arm can be left loose on column and head swung about for routing and similar operations. Permits drill head to be mounted above or below arm for more versatile operation.

Extra heavy casting of rugged construction provides necessary rigidity. Co-ordinate clamps lock arm rigidly to column. Can be used only with floor type drill press having 2 3/4-inch outside diameter column, such as 99 AM 2314 drill press on page 20. 99 A 02418—Shipping weight 35 lbs. \$21.50

Drill Press Collar

E Locks on column under drill press head. Makes it easy to swing head when head clamp is released. Use on drill presses on page 20 or any drill with a 2 3/4-inch outside diameter column.

9 A 2429—Shipping wt. 4 lbs. 8 oz. \$1.95

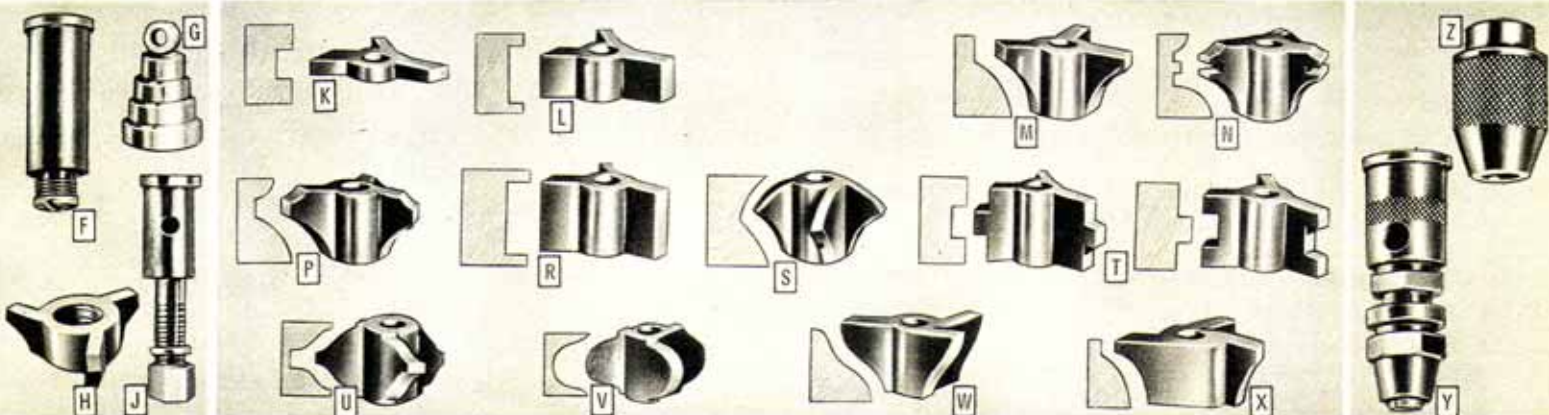

. . . increase tremendously the usefulness of your drill press

Adapters and Cutters

F Adapter for 9 A 2438 sash cutter below. Fits spindles of CRAFTSMAN drill presses 9A2362, 9A2364, 9A2313 and 9A2314 (see pages 20 and 21), or any drill press with No. 33 Jacobs taper spindle and knurled locking collar to hold adapter flange securely. 9 A 2437—Shipping weight 7 oz. \$1.35

G Shaper Collars. Mount beneath shaper cutters to control depth of cut on curved work. Fit 3/4-inch spindle. 9 A 2367—Shipping weight 6 oz. set \$1.80

H Sash Cutter. Threaded for use with adapter 9 A 2437 above. 9 A 2438—Shipping weight 4 oz. \$2.39

J Adapter for all 3/4-inch bore shaper cutters shown at right. Fits spindles of CRAFTSMAN drill presses 9A2362, 9A2364, 9A2313 and 9A2314 (pages 20 and 21), or any drill press with No. 33 Jacobs tapered spindle and knurled locking collar. 9 A 2435—Shipping weight 7 oz. \$1.29

Shaper Cutters for drill press or shaper

These high speed shaper cutters add tremendously to the usefulness of your drill press. Permit you to form almost any kind of contour quickly and accurately . . . do many types of shaping work. Made of finest quality special alloy tool steel; carefully hardened and ground for keen, long lasting edges. Precision machined and ground to exact dimensions. Cutters have 3/4-inch bore. Use with adapter 9A2435 at left when used on drill press with Jacobs taper. Sharpen by grinding front face on flat, fine grit wheel.

K 9 A 2319—1/4-in. high; 3/8-in. radius. Shipping weight 6 ounces. . . . Each \$1.42

L 9 A 2321—1/2-in. high; 3/8-in. radius. Shipping weight 6 ounces. . . . Each 1.70

M 9 A 2323—1-in. high; 3/8-in. radius. Shipping weight 6 ounces. . . . Each 2.00

N 9 A 2327—1-in. high; 3/8-in. radius. Shipping weight 6 ounces. . . . Each 2.00

P 9 A 2329—1-in. high; 3/8-in. radius. Shipping weight 6 ounces. . . . Each 2.00

R 9 A 2333—1-in. high; 3/8-in. radius. Shipping weight 6 ounces. . . . Each 1.95

S 9 A 2335—1-in. high; 3/8-in. radius. Shipping weight 6 ounces. . . . Each 2.00

T A complete matched set of tongue and groove cutters to be used in connection with your drill press or shaper. Precision ground and matched for accurate fit. 3/4-inch bore; 1-inch high; 3/8-inch radius. 9 A 2365—Shpg. wt. 10 oz. Set \$3.85

U 9 A 2345—Large size cutter. 1-inch high; 1 1/4-inch radius. Shipping weight 8 ounces. Each \$2.85

V 9 A 2346—Large size cutter. 1-inch high; 1 1/4-inch radius. Shipping weight 8 ounces. Each \$2.85

W 9 A 2347—Large size cutter. 1-inch high; 1 1/4-inch radius. Shipping weight 8 ounces. Each \$2.85

X 9 A 2348—Large size cutter. 1-inch high; 1 1/4-inch radius. Shpg. wt. 8 oz. Ea. \$2.85

Collet Chucks

Y For cutters at right or any 3/8 or 1/2-in. diam. shank. 3/4-in. capacity with 3/4-in. bushing. Fits any drill press with No. 33 Jacobs taper spindle having threaded locking collar on quill. Replaces three jaw chucks on any work developing side thrust, as in routing. Threaded collar holds chuck securely. Shpg. wt. 8 oz. 9 A 2455 \$1.29

Z Screw-on type collet chuck. 3/4-in. capacity. Use with cutters at right. Fits drill press or any spindle with 3/4-in. x 20 thread (see 9A2310 and 9A2172, page 29). Shpg. wt. 3 oz. 9 A 2271 95c

DRILL PRESS ACCESSORIES

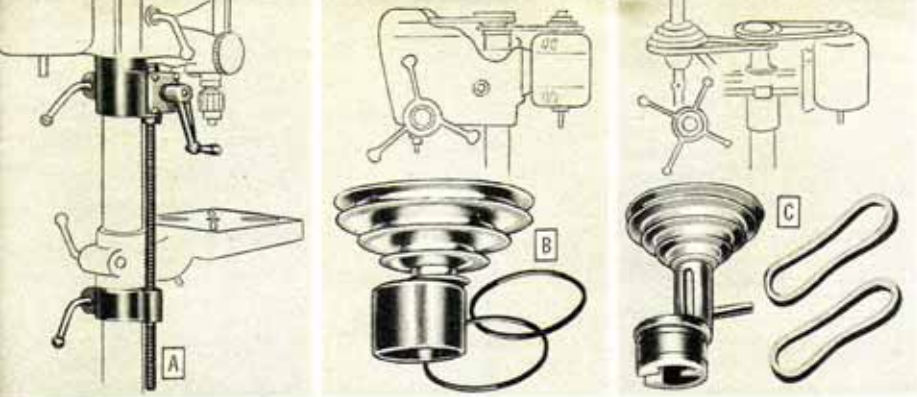

Head and Table Lift

A For CRAFTSMAN 99 AM 2314 and many other floor model drill presses with 2 3/4-inch outside diameter columns. For fast, easy raising or lowering of drill press head or table. Support collars for drill head and table are positioned by Acme-threaded lift screw with bevel-gear drive controlled by handy crank handle. Both support collars have co-ordinate clamp locks. When head support collar is tightened, lower collar may be loosened for raising or lowering table. Similarly, when table collar is tightened, it serves as support for positioning drill press head.

Each turn of crank gives 3/4-inch travel. Maximum travel at any one setting is 12 inches. Two bevel gears, thrust bearing and crankshaft are all housed in gear case which is cast in one piece with the upper support collar. Ball thrust bearing absorbs the load on the screw.

99 A 02419—Shpg. wt. 18 lbs. . . . \$20.50

CRAFTSMAN Multi-Speed Attachments

Use the correct speed for every job. The right speed means better performance and smoother cutting. Enables you to get the most out of your drill press. Gives 20 speeds from 200 R.P.M. to about 15,000 R.P.M. . . . 8 are under 1,000 R.P.M., a complete range for low speeds required for metal drilling even with 3/8-inch drills . . . remaining speeds offer correct, most efficient speed for wood drilling, shaping, routing, carving, dovetailing, etc. Finest ball bearing construction. Balanced pulley. 2 V-belts included. We recommend use of 3/4-H.P. 1750 R.P.M. motor (minimum) to secure high speeds.

B 9 A 2338—Fits 99 AM 2364, 99 AM 2313 and 99 AM 2314 (see page 20) and some other drill presses with 2 or 2 3/8-inch (plus .005-inch) inside diameter column. Shipping weight 5 pounds. . . . \$11.35

9 A 2399—(Not illustrated). Fits former drill presses 2482, 2483 and some others with 2 3/8-inch (plus .005-inch) inside diameter column. Shipping weight 5 lbs. . . . \$11.50

C 9 A 2394—Fits former drill presses 2407, 2392, 2423 and some others with 2 3/8-inch (plus .005-inch) inside diameter columns. Shipping weight 5 lbs. . . . \$11.50

9 A 2397—(Not illustrated). Fits former drill press 2380 and some others with 2-inch (plus .005-inch) inside diameter column. Shipping weight 5 pounds. . . . \$11.50

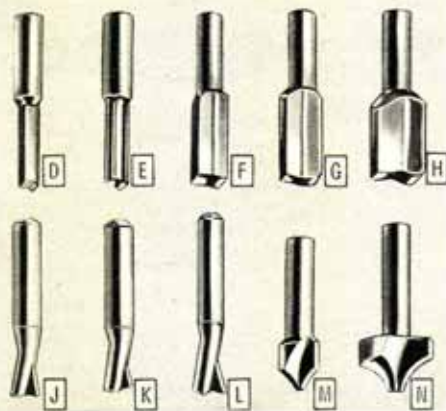

Woodworking Cutters

These handy drill press accessories permit you to do accurate carving, round-end mortising, dovetailing, boring, round edging, reeding and general routing. Precision made of the finest quality high speed steel, carefully ground with keen edges. Perfectly ground to exact dimensions. All have 3/8-inch shanks. Use with either 9A2455 or 9A2271 collet chucks shown on opposite page. Routing bits are used most efficiently when work is held against a fence to obtain parallel and accurate routing (see 9A2457 Hold-down Guide on opposite page). **Caution: Use these cutters in collet chucks only—NEVER in Jacobs or other three jaw drill chucks!** Shpg. wt. each 6 oz.

- D** 9 A 2400—3/8-inch router . . . \$1.25
- E** 9 A 2401—3/8-inch router . . . 1.35
- F** 9 A 2402—3/8-inch router . . . 1.40
- G** 9 A 2403—3/8-inch router . . . 1.60
- H** 9 A 2404—3/8-inch router . . . 1.85
- I** 9 A 2409—3/8-inch dovetail . . . 1.35
- J** 9 A 2410—3/8-inch dovetail . . . 1.40
- K** 9 A 2411—3/8-inch dovetail . . . 1.60
- L** 9 A 2415—3/8-inch carving . . . 1.60
- M** 9 A 2416—3/8-inch carving . . . 1.85

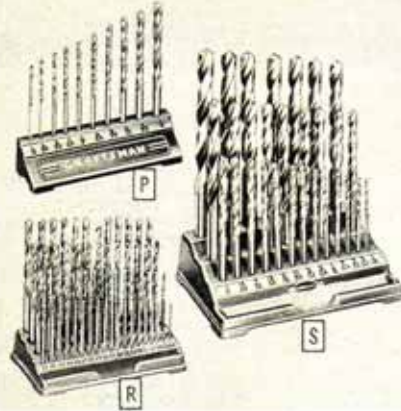

CRAFTSMAN Drill Sets

Our finest CRAFTSMAN twist drills for home, shop and industrial use. Your choice of low speed carbon tool steel or high speed steel. Use carbon tool steel drills for hand or breast drills; high speed drills for electric drills and power driven drill presses. Hardened and tempered to stay sharp; precision ground. Come in handy drill stands.

P Ten-piece drill sets in drill stand. Sizes 1/16, 1/8, 3/16, 1/4, 5/16, 3/8, 7/16, 1/2, 5/8 and 3/4-inch. Shipping weight per set, 8 oz.

9 A 6705—10-piece carbon tool steel drill set and stand. . . . \$1.89

9 A 6703—10-piece high speed steel drill set and stand. . . . 3.85

R Sets of sixty wire gauge drills sizes 1 to 60 in drill stands. Shpg. wt. per set, 2 lbs. 12 oz.

9 A 6701—60-piece carbon tool steel drill set and stand. . . . \$9.75

9 A 6707—60-piece high speed steel drill set and stand. . . . 18.50

S Sets of twenty-nine drills, sizes 1/16 to 3/4-inch by 64ths in stands. Shpg. wt. per set 4 lbs. 2 oz.

9 A 6702—29-piece carbon tool steel drill set and stand. . . . \$11.75

9 A 6704—29-piece high speed steel drill set and stand. . . . 24.75

Mortising Chisel Housing

CRAFTSMAN. Cut square holes with your drill press. Housing mounts on quill. Bit drills round hole; hollow chisel trims corners square. Makes your drill press a mortising machine that cuts clean, accurate mortise joints. Aid to woodworkers.

T 9 A 2463—Mortising Chisel Housing. For drill presses 99AM2314 and 99AM2313 (page 20) and 99AM2364, 99A2362, 99A-2310 (page 21). Use with 9A2420 and 9A-2422 (listed below) or almost any hollow chisel and mortising bit. Shipping weight 3 lbs. . . . \$4.65

U 9 A 2461—Mortising Chisel Housing. For former CRAFTSMAN drill presses Nos. 2380, 2382, 2407, 2423 and 2392. Use with 9A2420 and 9A2422 (listed below) or almost any hollow chisel and mortising bit. Shipping weight 3 lbs. . . . \$3.35

V 9 A 2420—Hollow Chisel. For 9A2463 and 9A2461 (listed above). 3/8, 3/4 and 1/2-inch. State size. Shpg. wt. 4 oz. \$3.50

W 9 A 2422—Mortising Bit. For 9A2420 (listed above). 3/8, 3/4 or 1/2-inch. Please state size. Shipping wt. 4 oz. . . . \$2.05

Dovetailing Attachment

X With this attachment you can make perfect dovetail joints like you see on desk and dresser drawers. Both pieces are cut at the same time. Pieces to be dovetailed are held at right angles in clamp so cutter may be guided through one piece into the other. Attachment includes a steel comb, to guide shank of router to predetermined depth, end plates, screw fittings and clamps for holding work. Wood parts and dovetail cutter are not included. With complete instructions.

9 A 2462—Shpg. wt. 4 lbs. 1 oz. . . . \$7.95

Barron Rotary Planer

Y Five tools in one! Does routing, planing, rabbeting and paneling. Dresses, trues-up and finishes all types of wood. Won't burn, gouge or scratch. Will plane and resurface 12x28-inch board in 45 to 60 seconds! Fits any drill press with 1/2-inch chuck capacity. Adapter for Jacobs No. 33 taper spindle is included.

Diameter 3 in.; 3/4-in. round arbor. Special molybdenum tungsten tool steel blades. Set includes: Adapter, Allen wrench, set-up gauge, push-down pin and instructions. (Shpg. wt. 2 lbs.)

9 A 2289—Postpaid. . . Complete set \$7.50

9 A 2281—3/4-inch long Replacement Blades, Postpaid. (Shpg. wt. 2 oz.) . . . 3 for \$1.75

Barron Planer Blade Holder. (Not shown). For resharpening planer blades at correct angle. Made of steel. With instructions. (Shipping weight 4 oz.)

9 A 2280—Postpaid. . . . Each 75c

Adapters for threaded spindle drill presses. Postpaid. (Shpg. wt. 7 oz.)

9 A 2254—1/2-in. 20 thread spindle . . . \$1.50

9 A 2251—3/4-in. 24 thread spindle . . . 1.50

Z Tapered Adapter. Enables you to fit #2 Morse male taper shank drill to #33 Jacobs male taper spindle.

9 A 2445—Shipping weight 8 oz. . . . \$2.45

Roto-Vert Senior

Z CRAFTSMAN. For drill press and electric hand drills having chuck capacity of 3/4-inch or greater. Converts electric drill or drill press into a power sawing and filing machine. Uses standard hack saw blades and files.

Only two moving parts . . . both made of tough, wear-resistant tool steel. No gears or springs to break or get out of order. Solid brass case has gray wrinkle finish; contrasting chromium plated trim. 5 1/4 inches long. Complete instructions.

9 A 2600—Shpg. wt. 2 lbs. 13 oz. . . . \$14.75

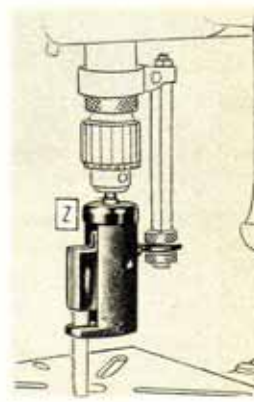
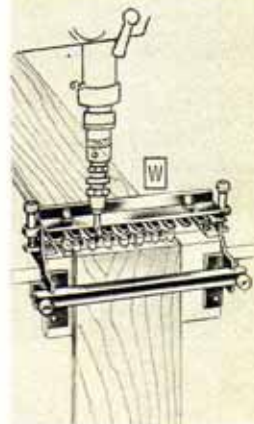
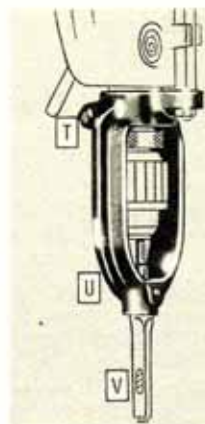

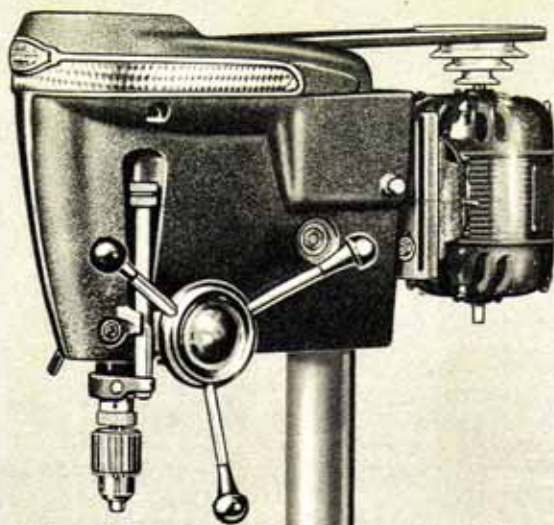

\$120.00 with motor

A
With-
out
Motor **\$92.50** CASH
\$9.50 DOWN . . ON
EASY TERMS



Jacobs No. 6A-33 Chuck for use with No. 33 Jacobs Taper Arbor supplied with CRAFTSMAN "100" Drill Presses. Capacity 0 to 1/2 inch. Precision made.

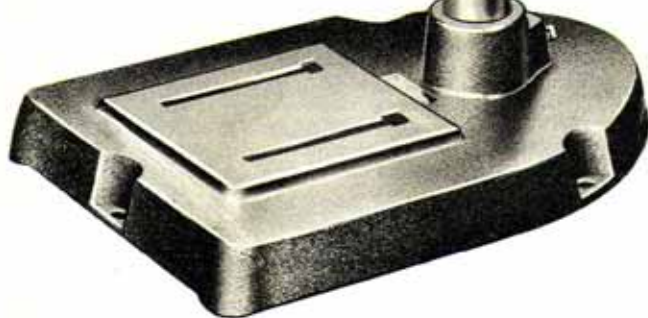

CRAFTSMAN
THE RIGHT WAY
TO SAY
**HARDWARE
AND TOOLS**

\$108.00 with motor

B
With-
out
Motor **\$80.50** CASH
\$8.50 DOWN . . ON
EASY TERMS

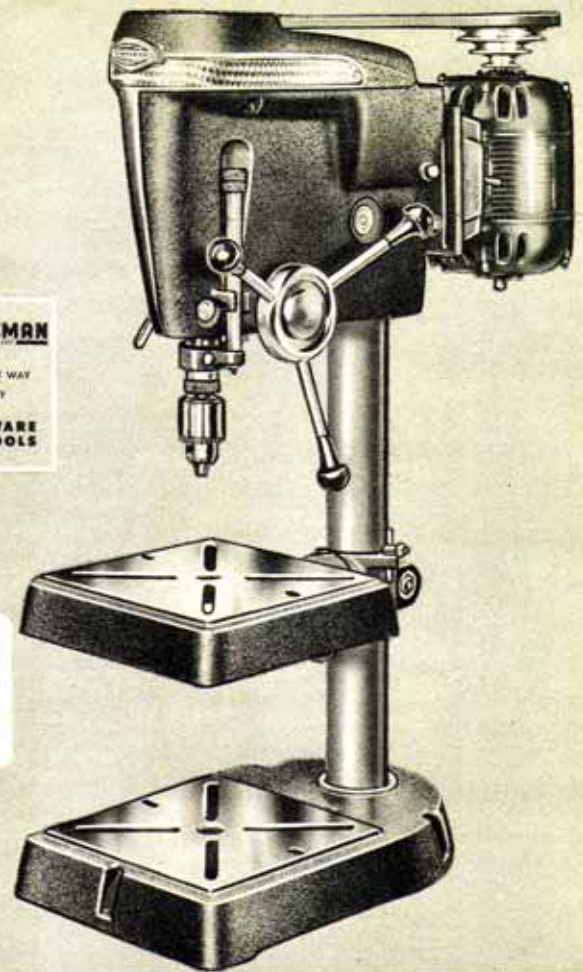

CRAFTSMAN heavy duty type

Drills to the center of 15-inch circle

CRAFTSMAN "100" heavy duty Drill Press. Packed with power and capacity. Gives accuracy in operation not found in others several times the cost. Notice the modern designed streamlined head . . . no unsightly spindle extending above head . . . easy-acting three lever feed handle. This drill press will give you superb performance on those steady day-in day-out production jobs.

Perfect accuracy. You'll be able to do work that's accurate to the thousandths of an inch. The table is held in perfect alignment at 0 degrees by a taper pin. Absolutely prevents table from tilting even a fraction of an inch. Pin is removable for tilting table from 0 to 90 degrees right or left.

Double-acting shoe locks. Securely lock head to column, table to column and quill. Precision made . . . keeps table, column and head in perfect alignment. Operated by convenient handles on the side.

New spiral coil spring for quill return practically eliminates breakage. Quill return shock absorbed by rubber cushion. Pre-loaded ball bearings in quill. Extra long quill support in head casting. Has famous "Floating Drive" spindle assembly. Spindle has No. 33 Jacobs taper. Built-in holder for chuck key.

SPECIFICATIONS:	A 99 A 2314	B 99 A 2313
• Depth of throat	7 3/4 inch	7 3/4 inch
• Spindle	No. 33 Jacobs Taper	No. 33 Jacobs Taper
• Bearings	4 heavy duty ball	4 heavy duty ball
• Chuck capacity (Jacobs 6A-33) . . .	0 to 1/2 inch	0 to 1/2 inch
• Spindle travel	4 inches	4 inches
• Depth gauge, graduations	1/16 of an inch	1/16 of an inch
• Column diameter (outside)	2 3/4 inches	2 3/4 inches
• Table size	10x10 inches	10x10 inches
• Table travel	41 1/2 inches	13 3/2 inches
• Distance table to chuck, maximum . .	41 1/2 inches	13 3/2 inches
• Distance base to chuck, maximum . .	45 5/8 inches	17 3/8 inches
• Machine and motor pulley (in- cluded)	5 in. 4 step	5 in. 4 step
• Motor recommended, minimum . . .	3/4 H.P. 1750 RPM	3/4 H.P. 1750 RPM
• 11 speeds from	625 to 5000 RPM	625 to 5000 RPM
• Mounting dimensions	16 1/2 x 14 1/2 inches	9 1/2 x 14 1/2 inches
• Overall dimensions: Height	68 3/4 inches	36 3/8 inches
Width	18 3/4 inches	12 3/8 inches
Depth	24 inches	19 inches

A 99 A 2314—Floor model without motor. Shipping weight 179 lbs. **\$92.50**
 99 A 2331—Floor model with 3/4 H.P. 1750 R.P.M. capacitor ball bearing.
 110-120-volt 60 cycle A. C. motor. Shipping weight 214 pounds. **\$120.00**
B 99 A 2313—Bench model without motor. Shipping weight 135 lbs. **80.50**
 99 A 2330—Bench model with 3/4 H.P. 1750 R.P.M. capacitor ball bearing
 110-120-volt 60 cycle A. C. motor. Shipping weight 170 pounds. **\$108.00**



CRAFTSMAN Drill Press . . improved models

Ball bearing Drill Press

A It's the CRAFTSMAN "100". The sturdy, rugged drill press for your wood and metal work. Designed to give utmost accuracy. Notice that the spindle does not project above head . . . Sears new modern, compact, streamlined design. It's a beauty.

Drills to center of 13½-inch circle. Maximum spindle travel 3¼ inches. Adjustable stop collar with lock can be set for repetitive drilling.

Perfectly aligned table. Tapered pin holds the 9x9-inch table on support in perfect alignment at horizontal position. Table can be tilted 0 to 90 degrees either right or left. Made of smooth ground cast iron.

Coil spring for quill return. Practically eliminates breakage. Rubber cushion absorbs quill shock. Long quill support in head casting. Quick-acting double shoe quill lock. "Floating Drive" spindle assembly gives smoother operation. Sliding feed handle easily adjusted.

SPECIFICATIONS:

- Depth of throat 6¾ inches
- Spindle No. 33 Jacobs taper
- Bearings 4 sets heavy duty ball
- Chuck capacity 0 to ½ inch
- Spindle travel 3¼ inches
- Depth gauge graduations ¼ inch
- Outside column diameter 2¼ inches
- Table size 9x9 inches
- Table travel 10 ⅝ inches
- Table to chuck, maximum 10 ⅝ inches
- Base size 11x16 ⅝ inches
- Base to chuck, maximum 14 ⅜ inches
- Machine and motor pulley (included) 5 in. 4 step V-Cone type
- Motor recommended, minimum ½ HP. 1750 R.P.M.
- Eleven speeds 625-5000 R.P.M.
- Mounting dimensions 8 ⅞ x 12 ½ inches
- Over-all dimensions: Height 31 ¾ inches; width 11 ½ inches; depth 16 ⅝ inches.

99 AM 2364—Without motor. Shpg. wt. 107 lbs. . . \$69.50
 99 AM 2366—With ½ H.P. 1750 R.P.M. capacitor 110-120-volt 60-cycle A.C. ball bearing motor. Shpg. wt. 142 lbs. \$97.00

Bronze bearing Drill Press

B CRAFTSMAN "80" . . . one of our lower priced drill presses. Ideal for drilling operations in smaller shops. Efficient work can be done on either wood or metal.

Drills to center of 12¼-inch circle. Spindle travel 3 inches. Runs on three long-life, self-lubricating oilite bronze bearings; ball thrust bearing absorbs spindle thrust. Adjustable stop collar for repetitive drilling.

Famous "Floating Drive" spindle assembly. Eliminates "whip"; absorbs belt pull. New improved spiral coil spring quill return. Rubber cushion absorbs quill return shock. Feed lever handle quickly adjusted for greater leverage. 7¾-inch square table. Provides ample working surface. Table is non-tilting.

SPECIFICATIONS:

- Depth of throat 6¾ inches
- Spindle ½-20 thread or No. 33 Jacobs Taper
- Bearings 1 ball thrust; 3 porous bronze
- Chuck capacity 0 to ½ in. or Jacobs ⅜ to ½ in.
- Spindle travel 3 inches
- Outside diameter of column 1 ¾ inches
- Table size 7 ¾ x 7 ¾ inches
- Table travel 8 ¾ inches
- Table to chuck (maximum) 8 ¾ inches
- Base size 9x14 inches
- Base to chuck (maximum) 11 ⅝ inches
- Machine and motor pulley (included) 4 inch 4 step
- Motor recommended, minimum ½ H.P. 1750 R.P.M.
- Eleven speeds 750 to 4000 R.P.M.
- Mounting dimensions 7 ⅝ x 11 ⅝ inches
- Overall dimensions; Height 26 ¾ inches; width 10 ½ inches; depth 15 ⅝ inches.

Three-jaw self-centering chuck and V-belt are included.
 99 AM 2310—Without motor. Shpg. wt. 77 lbs. . . \$40.00
 99 AM 2311—With ½ H.P. 1750 R.P.M. split phase 110-120-volt A.C. ball bearing motor. Shpg. wt. 106 lbs. \$57.50

C 99 AM 2362—Similar to 99 AM 2310 above but equipped with No. 33 Jacobs tapered spindle and No. 33 Jacobs key chuck ¾ to ½ inch capacity. Shpg. wt. 77 lbs. \$46.50
 99 AM 2363—Same as 99 AM 2362 with ½ H.P. 1750 R.P.M. split phase 110-120-volt A.C. motor. Shpg. wt. 107 lbs. \$64.00

Low priced Drill Press

D This CRAFTSMAN "40" has the same rugged construction and quality as our other CRAFTSMAN Drill Presses but is built for smaller utility. You can now have a good low priced drill press in your hobby or small work shop. Can be used for drilling wood or metal.

Drills to center of 9-inch circle. Maximum spindle travel 1 ⅜ inches. Equipped with top quality self-lubricating oilite bronze bearings.

Adjustable head, table and idler drive.

SPECIFICATIONS:

- Depth of throat 4 ½ inches
 - Spindle ½-20 thread
 - Bearings 3 porous bronze, 1 ball thrust
 - Chuck capacity 0 to ¾ inch
 - Spindle travel 1 ⅜ inches
 - Outside column diameter 1 ⅝ inches
 - Table size 5 ½ x 5 ½ inches
 - Table travel 10 ¼ inches
 - Table to chuck, maximum 10 ¼ inches
 - Base size 6x6 inches
 - Base to chuck, maximum 11 ½ inches
 - Machine pulley (included) 3 inch; 3-step Cone type for ¾-in. "V" Belt
 - Motor pulley (not included) 3 inch; 3-step Cone "V" type
 - Motor recommended, minimum ¼ H.P. 1750 R.P.M.
 - Belt (included) ¾ x 56 inch.
 - Seven speeds 1150 to 3450 R.P.M.
 - Mounting dimensions 8x6 ¾ inches
 - Overall dimensions: Height 24 ⅝ inches; depth 13 ¾ inches; width 7 ¼ inches.
- 99 A 02172—Without motor. Shipping weight 26 pounds. \$19.00
 99 AT 2166—With ½ H.P. 1750 R.P.M. split phase, ball bearing, 110-120-volt 60-cycle A.C. motor, 3 step cone type motor pulley. Shipping weight 55 pounds. \$37.50

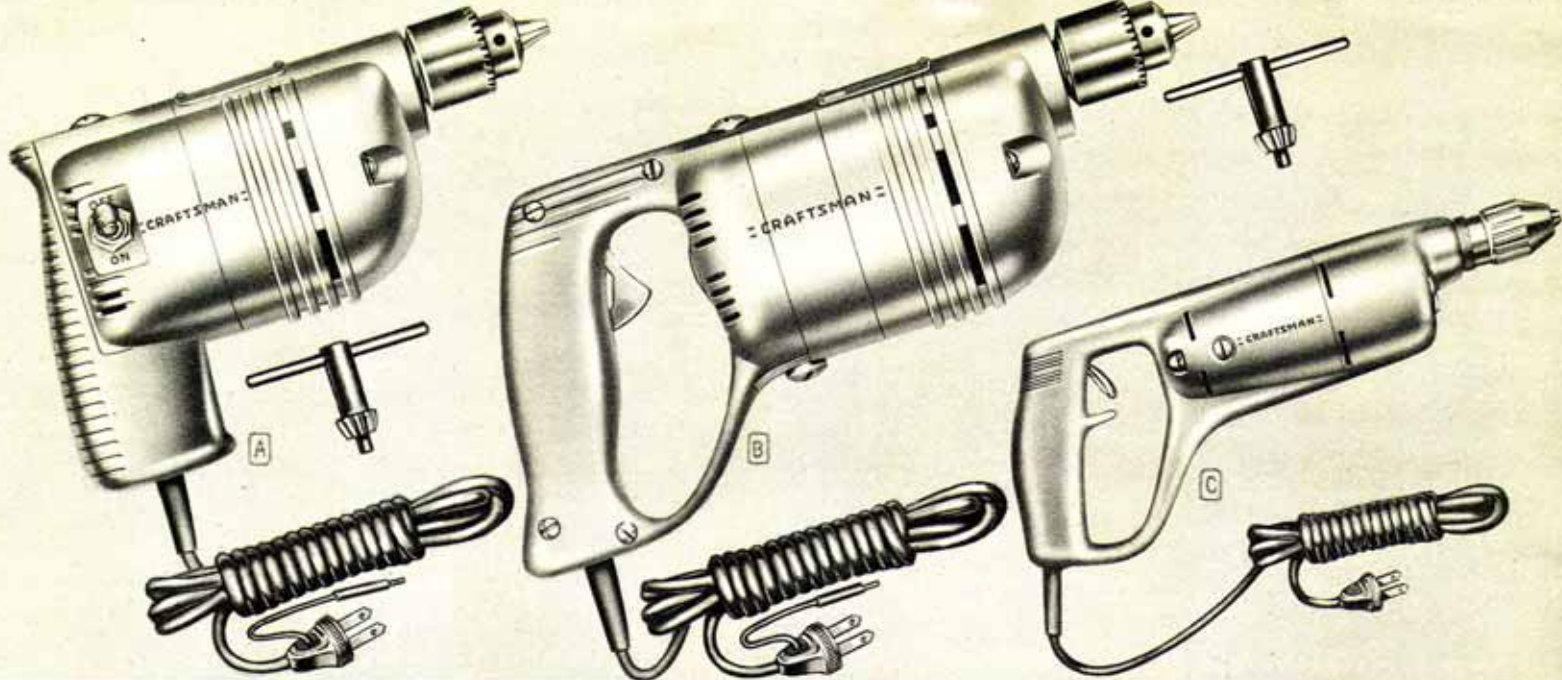

CRAFTSMAN Electric Drills . . . pack lots of power

Here are the tremendously popular, powerful, small size electric drills that are taking the place of large, heavy, hard-to-handle drills. Why? These CRAFTSMAN "80" electric drills are small . . . light . . . easy to handle . . . literally power-packed. We tried but just couldn't stall one using a $\frac{1}{4}$ -inch bit on steel plate.

Expertly designed and engineered. Lightweight die-cast aluminum frame is exceptionally strong for its weight . . . drill actually weighs less than 3 pounds. Approved by Underwriters' Laboratories, Inc.

Precision ball bearings at points of greatest wear . . . one as thrust bearing, one at gear end of motor. Needle bearing on chuck gear spindle. Gives true-running, dependable long life. Equipped with famous No. 1B Jacobs $\frac{1}{4}$ -in. geared key chuck which seats drills firmly yet can be quickly and easily removed.

Double reduction gears are cut from special alloy steel . . . are perfectly meshed for smooth, quiet op-

eration and lower, more practical spindle speed of 1600 R.P.M. Equipped with powerful universal motor for use on 110-120-volt, 25-60-cycle A.C.-D.C.

Comes with 10 feet of three-wire rubber covered cord and unbreakable plug. The ideal tool for utility or general maintenance use. Your choice of either pistol-grip or saw-grip models.

- A** 9 A 2577—Pistol-grip model. Has single pole toggle switch. Over-all length 7 $\frac{3}{4}$ inches. Shipping weight 4 pounds 4 ounces. **\$24.50**
- B** 9 A 2578—Saw-grip model. Has single pole safety trigger switch. Over-all length 9 $\frac{3}{4}$ inches. Shipping weight 4 pounds 8 ounces. **\$24.50**

Saw-Grip Model
\$24.50
CASH
\$2.50 DOWN

CRAFTSMAN "40" $\frac{1}{4}$ -inch Drill

C New! Completely new . . . both inside and out. Fine quality, light, utility electric drill for home craftsmen who want big-tool design and precision construction at low cost. Compact and strong. Has power and torque to drive $\frac{1}{4}$ -inch bits into steel. Approved by Underwriters' Laboratories, Inc.

\$14.95

Sturdy 110-120-volt 25 to 60-cycle A.C.-D.C. universal motor has Formex insulated armature and field coils for maximum protection against motor burn-out. Jacobs $\frac{1}{4}$ -inch "Hand-tite" chuck. Bronze bearings throughout for smooth, quiet operation. Double reduction gears of alloy steel. 1600 R.P.M. Die-cast aluminum frame has saw-grip handle. With 6-ft. rubber covered cord and plug. 12 in. long.

9 A 2575—Shipping weight 3 lbs. 12 oz. **\$14.95**

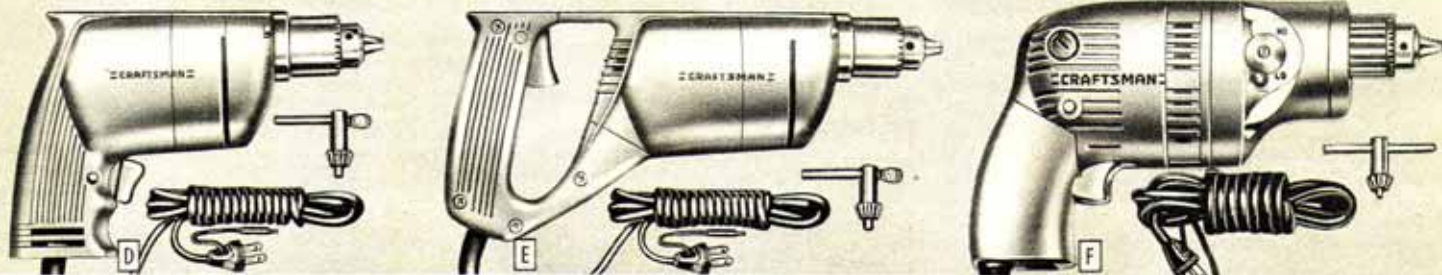

CRAFTSMAN "100" $\frac{1}{4}$ -inch heavy duty Electric Drills

Here's just the drill for those heavy jobs where a compact, lightweight $\frac{1}{4}$ -inch drill is needed. We believe it is the finest combination of maximum power, lightweight and compact design of any drill of this type on the market. The ideal tool for production line service . . . will give long, efficient service in your shop, or in the factory.

Super-powered. Will not stall on the toughest job. Built for production-line service. Will take the day after day punishment of continuous operation and give dependable long-life service. Not a standard, but a heavy duty drill.

Accurately balanced, power packed universal motor runs smooth and cool. For use on 110-120-volt 25 to 60-cycle A.C.-D.C. Automatic safety release trigger switch has lock button for continuous running. Underwriters' Laboratories approved.

Excellent design and construction, both inside and out. Strong die cast aluminum frame makes this drill unusually light weight. Compact functional design . . . your choice of either easy-to-hold pistol or saw-grip handled models.

Equipped with precision ball bearings throughout. Needle roller bearing on chuck spindle. Double reduction gears of nickel chrome molybdenum steel for long life and quiet transmission of greatest power. No-load chuck speed of 1600 R.P.M. Chuck is largest and finest available for drill of this type . . . heavy duty $\frac{1}{4}$ -inch Jacobs No. 7B geared key chuck.

Each drill supplied with 10-ft. three-wire rubber covered cord and unbreakable plug and Jacobs chuck key. Your choice of two models.

- D** 9 A 2570—Pistol-grip model. 7 $\frac{3}{4}$ inches long. Shipping weight 5 pounds. **\$34.50**
- E** 9 A 2571—Saw-grip model. 10 $\frac{3}{4}$ inches long. Shipping weight 5 pounds 3 ounces. **\$34.50**

Your Choice
\$34.50
CASH
\$3.50 DOWN

CRAFTSMAN 2-speed Drill

F You can now have the best speed for every job with this CRAFTSMAN electric drill. Exclusive convenient gear shift permits change of speed without loss of power. Two speeds—2000 R.P.M. in low gear for general work and 4000 R.P.M. in high gear for high speed drilling . . . best for small size bits.

\$39.95
CASH
\$4.00 DOWN

Die-cast aluminum housing makes it lightweight and easy-to-handle, yet rugged and sturdy. Precision ball bearing construction throughout. Equipped with $\frac{1}{4}$ -in. No. 1B famous Jacobs geared key chuck. Handy trigger switch has locking button for continuous operation. Fan-cooled universal motor for use on 110-120-volt, 25 to 60-cycle A.C.-D.C.

Comes with 10-foot three-wire rubber covered cord and unbreakable plug and Jacobs chuck key. Over-all length 10 $\frac{3}{4}$ inches.

9 A 2550—Shipping weight 5 pounds. **\$39.95**

Why not pay for your equipment while using it? See inside front cover for details on Sears Easy Terms.

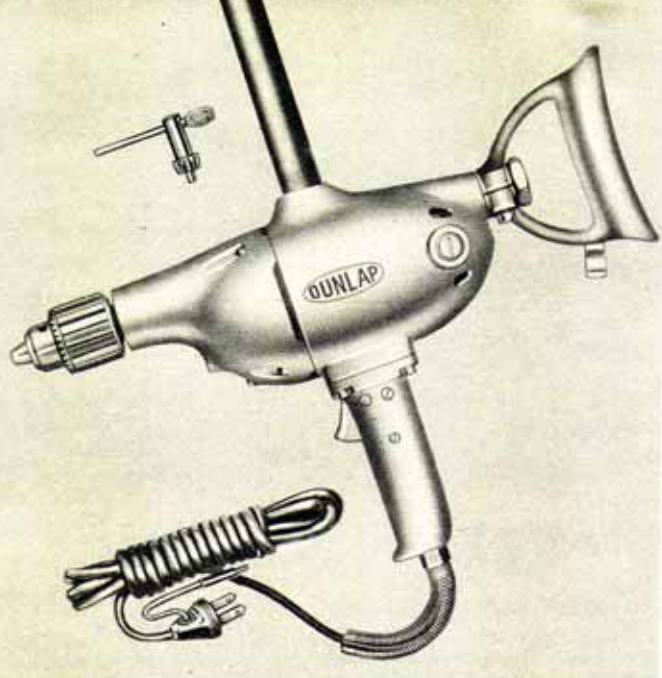

DUNLAP 1/2-inch Electric Drill

Has that extra power necessary for those tough jobs. Ideal utility drill for farmers, garage mechanics and maintenance men. It's well balanced and easy to handle. Runs smoothly and quietly without chatter.

\$39.95
CASH
\$4 DOWN...

Gears, pinions, motor shaft and chuck spindle are heat treated alloy steel. Double reduction gears are heat treated chrome nickel steel... improve with use. Self-lubricating bronze oilite bearings. Ball thrust bearing on spindle takes up end thrust. Streamlined housing made of sturdy, yet lightweight aluminum alloy. Top handle and rear grip are removable for close quarter work.

Equipped with 1/2-inch capacity No. 33B Jacobs geared key chuck... finest chuck available. Underwriters' Laboratories approved, fully enclosed, double-pole automatic releasing switch; locks for continuous running. Powerful universal motor operates on 110-120-volt, 25 to 60-cycle A.C.-D.C. No-load spindle speed 400 R.P.M. most practical for general drilling, hole saws, wood augers, twist drills, cylinder grinders, etc. Complete with 10-foot three-wire rubber-covered cord and unbreakable plug. Over-all length 16 inches.

99 A 02584—Shipping weight 15 pounds \$39.95

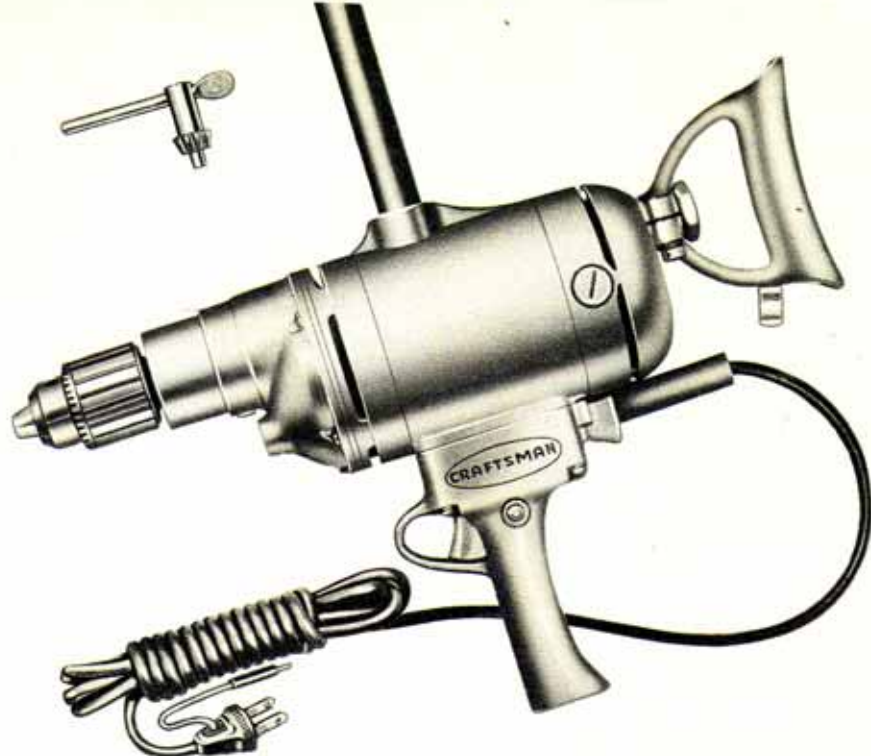

CRAFTSMAN production-type Drills

Built for heaviest production work in shop, factory or mill. Has plenty of surplus power... really power packed... won't stall on any job when used with the largest drill size specified. Special triple reduction gears are heat treated chrome-nickel steel... supply extremely high torque. Armature shaft runs smoothly on New Departure ball bearings; sealed in oil. Equipped with genuine Jacobs geared key chuck. Underwriters' Laboratories approved double-pole switch locks for continuous running. Lightweight aluminum frame and modern design give maximum operating ease and efficiency. Top and rear handles removable for more versatile operation, makes it especially suitable for close quarter work. Heavy duty universal ball bearing motor for use on 110-120-volt, 25 to 60-cycle A.C.-D.C. Comes with 10 feet of 3-wire, rubber-covered cord and unbreakable plug. Over-all length 18 1/2 inches.

\$64.95
CASH
99 A 02585
\$6.50 DOWN

99 A 02585—1/2-inch drill, 750 R.P.M. Shipping weight 27 pounds \$64.95
99 A 02586—3/4-inch drill, 525 R.P.M. Shipping weight 30 pounds 71.95
99 A 02587—3/4-inch drill, 475 R.P.M. Shipping weight 31 pounds 76.95

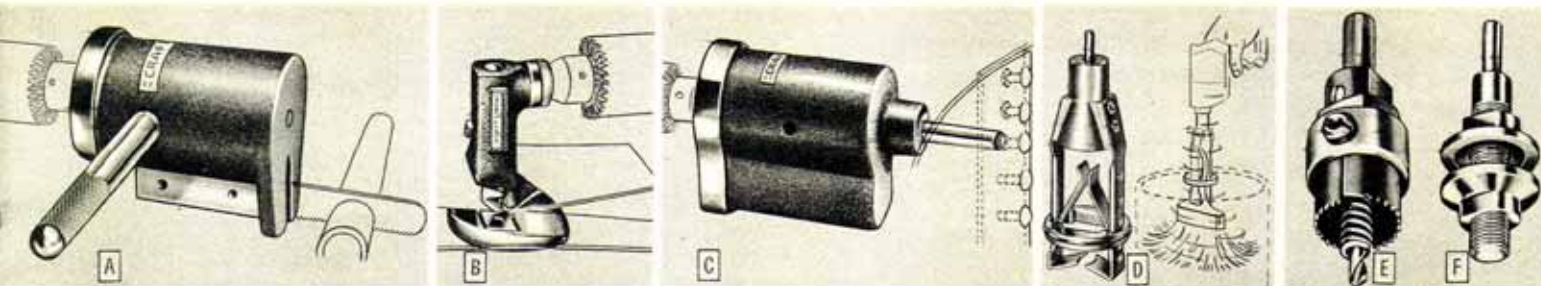

Accessories to give your 1/4-in. drill new uses

Solid brass cases, with gray wrinkle finish. Only two moving parts in each tool; no gears or springs. All working parts made of tool steel, accurately machined and assembled for smooth operation and long life. For general application on drills from 1600 to 2500 R.P.M. Easily attached. Complete instructions included.

sembled for smooth operation and long life. For general application on drills from 1600 to 2500 R.P.M. Easily attached. Complete instructions included.

Roto-Vert

A CRAFTSMAN. Your 1/4-inch electric drill becomes a portable power saw and filing machine when you attach this roto-vert. Ideal for cutting straight or irregular shapes in wood, metal, wall-board, etc. Fine for close quarters and hard-to-get-at places. Uses standard hack saw blades and files. Used by electricians, plumbers, heating and ventilating men in home and auto repair shops. Length 3 3/4 inches. Shpg. wt. 2 lbs.
9 A 2590 **\$12.50**

Roto-Snip

B CRAFTSMAN. Now you can do metal shearing two to three times faster. Eliminates the tiring work of cutting metal with hand snips. Roto-Snip converts 1/4-inch electric drills into a power shears. Cuts sheet metal up to 20-gauge, either straight or circle, down to 1 1/2-inch radius. Scribe lines can be followed easily. Cutting edges easily adjusted and resharpened. Height 3 3/4 inches. Shpg. wt. 2 lbs.
9 A 2591 **\$18.75**

CRAFTSMAN Roto-Pein

C Converts 1/4-in. electric drill into power hammer. Complete with riveting attachment. Length 4 1/4 in.
9 A 2592—Shipping weight 2 pounds 3 ounces **\$12.50**
9 A 2595—3/4-inch Concrete Drill. Shipping weight 4 ounces. **.79c**
9 A 2596—3/16-inch Cold Chisel. Shipping weight 3 ounces **.49c**
9 A 2597—3/4-inch Wood Chisel. Shipping weight 3 ounces **.79c**
9 A 2598—3/16-inch Center Punch. Shipping weight 3 oz. **.49c**
9 A 2599—Set of two 3/16-in. tool steel blanks. Shpg. wt. 3 oz. **.49c**

Electric Drill Attachments

D Spin-a-Brush Attachment changes your electric drill into a speedy paint brush cleaner. Use with any 1/4-inch or larger capacity electric drill. Easy to use! Simply fasten spin-a-brush in your drill chuck, insert brush, soak in cleaner, and spin. Cleans brush thoroughly in just 90 seconds. Die-cast cup and ring, with spring steel arms. Nickel plated.
9 A 2605—3/4-in. diam. steel shank. Shpg. wt. 1 lb. **\$2.19**

E Circular Hole Saw. For electric drills. Finest heat treated high speed steel. Cut clean, round holes in wood or metal. Depth of cut 3/4 inches. Use 1/2-inch drill or larger. Comes complete with mandrel. *Please state size wanted.*

Size, in.	3/4	1	1 1/4	1 1/2	2	2 1/2
Shpg. wt.	8 oz.	9 oz.	14 oz.	15 oz.	1 lb. 4 oz.	1 lb. 6 oz.
9 A 2698	\$3.69	\$3.69	\$3.69	\$3.69	\$4.10	\$4.59

Saw Blade only for circular hole saw

Size, in.	3/4	1	1 1/4	1 1/2	2	2 1/2
Shpg. wt.	5 oz.	6 oz.	8 oz.	9 oz.	12 oz.	15 oz.
9 A 2697	89c	89c	89c	89c	\$1.29	\$1.79

F Arbor for electric drill. For holding grinding wheels, wire wheels, buffing wheels, etc. 3/4-inch shank. Arbor is 3/4-inch by 20 thread. 3 5/16 inches long. 1 1/4-inch flanges and nuts in one piece. Precision made of carbon steel.
9 A 2594—Shipping weight 6 ounces. **58c**



\$20³⁰
Set complete in box
\$2.50 DOWN . .

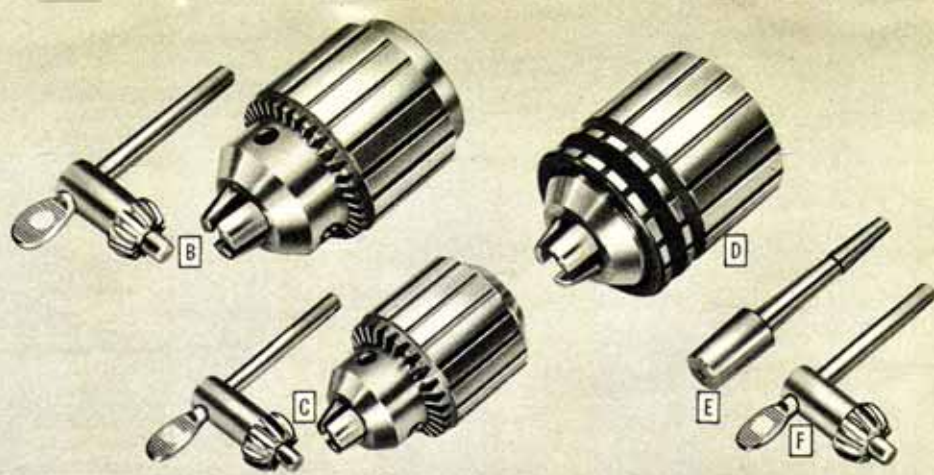

Jacobs Chucks for drill presses, lathes, electric drills, etc.

Genuine Jacobs chucks and arbors, nationally famous for their correct design, excellence of materials and precision manufacture. *All Jacobs chucks and accessories described on this page are postpaid*

Jacobs Commutator Kit

A For holding armature shafts rigidly during reconditioning. Kit includes: No. 75A armature driving chuck; No. 100 center rest chuck ($\frac{3}{4}$ to $\frac{3}{8}$ -inch capacity); two arbors (No. 2 Morse taper, shank end; No. 3 Jacobs taper head end); chuck key. Kit comes complete in strong metal box.
9 A 2129T—Postpaid. (Shipping weight 7 pounds 4 ounces)..... **\$20.30**

Jacobs Headstock Chucks

B 9 A 2044—Jacobs No. 55B. Capacity 0 to $1\frac{1}{2}$ in. Fits only 1-in. 8-thread spindle. Cannot be used with any type of arbor. Postpaid. (Shipping weight 3 pounds 10 ounces)..... **\$12.00**
9 A 2144—Jacobs No. 58B. Capacity $\frac{1}{4}$ to $\frac{3}{8}$ inch. Fits $1\frac{1}{4}$ -inch, 8-thread spindle. Can also be used with No. 3 Jacobs taper arbor. Postpaid. (Shipping weight 3 pounds 12 ounces)..... **\$15.00**
9 A 2121—Jacobs No. 59B. Capacity $\frac{1}{8}$ to $\frac{3}{8}$ inch. Fits only $1\frac{1}{4}$ -inch 8-thread spindle. Cannot be used with any type of arbor. Postpaid. (Shipping weight 5 pounds 8 ounces)..... **\$18.00**

Jacobs Drill Chucks for No. 33 Jacobs Taper Arbor

C 9 A 2142—Jacobs No. 33 Key-type chuck. Fits arbors with No. 33 Jacobs taper. Capacity $\frac{5}{64}$ to $\frac{1}{2}$ inch. Postpaid. (Shpg. wt. 1 lb. 8 oz.)..... **\$6.50**
9 A 2143—Jacobs No. 6A-33 key-type chuck. Fits arbors with No. 33 Jacobs taper. Capacity 0 to $\frac{1}{2}$ inch. Postpaid. (Shpg. wt. 2 lbs. 8 oz.)..... **7.50**

Jacobs Center Rest Chuck

D 9 A 2991—Jacobs No. 100CR. Capacity $\frac{1}{4}$ to $\frac{3}{8}$ inch. Must be used with No. 3 Jacobs taper arbor to support centerless armatures, etc. Postpaid. (Shipping weight 3 pounds 2 ounces)..... **\$10.00**

Jacobs Chuck Arbors

Precision ground . . . extremely accurate . . . to insure maximum accuracy of machine spindle and chuck performance.

E Jacobs chuck arbors to fit 9 A 2142 and 9 A 2143 chucks, listed at left.
9 A 2131—No. 0 Morse taper and No. 33 Jacobs taper. Postpaid. (Shipping weight 8 ounces)..... **85c**
9 A 2123—No. 1 Morse taper and No. 33 Jacobs taper. Postpaid. (Shipping weight 10 ounces)..... **85c**
9 A 2124—No. 2 Morse taper and No. 33 Jacobs taper. Postpaid. (Shipping weight 14 ounces)..... **85c**
For 9 A 2129, 9 A 2144 and 9 A 2991 Jacobs chucks, listed at left.
9 A 2133—No. 0 Morse taper and No. 3 Jacobs taper. Postpaid. (Shipping weight 10 ounces)..... **85c**
9 A 2154—No. 1 Morse taper and No. 3 Jacobs taper. Postpaid. (Shipping weight 12 ounces)..... **85c**
9 A 2126—No. 2 Morse taper and No. 3 Jacobs taper. Postpaid. (Shipping weight 14 ounces)..... **85c**

Jacobs Chuck Keys

F 9 A 2051—Jacobs No. 1 key. Fits Jacobs following chucks: Nos. 1, 1A, 1B, 1BB, 1BS. Postpaid. (Shipping weight 4 ounces)..... **30c**
9 A 2054—Jacobs No. 32 key. Fits following Jacobs chucks: Nos. 32, 32B, 32BB, 33, 33B, 33BB, 9, 11, 381. Postpaid. (Shpg. wt. 7 oz.)..... **40c**
9 A 2052—Jacobs No. 3 key. Fits following Jacobs chucks: Nos. 3, 3A, 3B, 3AE, 6, 6A-2A, 6A-33, 6B, 6AE, 14, 34, 34B, 54B, 55B, 56B, 58B, 75A. Postpaid. (Shipping weight 8 ounces)..... **50c**
9 A 2053—Jacobs No. 4 key. Fits following Jacobs chucks: Nos. 4, 16, 18, 36, 36B, 59B. Postpaid. (Shipping weight 12 ounces)..... **75c**

Sears Easy Terms make it easy for you to have a completely equipped power tool shop . . . see inside front cover

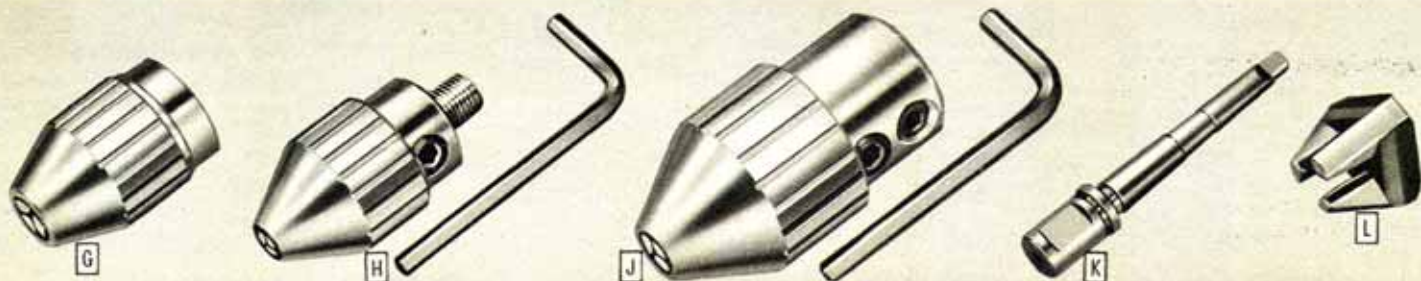

Jacobs Hand Tite Chucks

For use with many electric tools.
G 9 A 2175—Jacobs No. 4164. Capacity 0 to $\frac{1}{4}$ in. Tapped $\frac{1}{2}$ in. x 20-thread. Postpaid. (Shpg. wt. 8 oz.)..... **\$1.30**
9 A 2145—Jacobs No. 4165. Capacity 0 to $\frac{3}{8}$ inch. Tapped $\frac{1}{2}$ in. x 24-thread. Postpaid. (Shpg. wt. 8 oz.)..... **\$1.30**
9 A 2146—Jacobs No. 4191. Capacity 0 to $\frac{1}{4}$ inch. Tapped $\frac{3}{8}$ in. x 24-thread. Postpaid. (Shpg. wt. 8 oz.)..... **\$1.30**
9 A 2176—Jacobs No. 4364. Capacity 0 to $\frac{3}{8}$ inch. Tapped $\frac{1}{2}$ in. x 20-thread. Postpaid. (Shpg. wt. 1 lb. 2 oz.)..... **\$2.00**
9 A 2147—Jacobs No. 4365. Capacity 0 to $\frac{3}{8}$ inch. Tapped $\frac{1}{2}$ in. x 24-thread. Postpaid. (Shpg. wt. 1 lb. 2 oz.)..... **\$2.00**
9 A 2177—Jacobs No. 4464. Capacity $\frac{1}{8}$ to $\frac{1}{2}$ in. Tapped $\frac{1}{2}$ in. x 20-thread. Postpaid. (Shpg. wt. 1 lb. 2 oz.)..... **\$2.00**
9 A 2149—Jacobs No. 4465. Capacity $\frac{1}{8}$ to $\frac{1}{2}$ in. Tapped $\frac{1}{2}$ in. x 24-thread. Postpaid. (Shpg. wt. 1 lb. 2 oz.)..... **\$2.00**

Jacobs Hex Key Chucks

For use with many electric tools.
H 9 A 2992—Jacobs No. 6141. Capacity 0 to $\frac{1}{4}$ in. Spindle $\frac{3}{8}$ in. x 24-thread. Postpaid. (Shpg. wt. 12 oz.)..... **\$2.30**
9 A 2993—Jacobs No. 6344. Capacity 0 to $\frac{3}{8}$ inch. Spindle $\frac{1}{2}$ in. x 20-thread. Postpaid. (Shpg. wt. 1 lb. 8 oz.)..... **\$4.00**
9 A 2999—Jacobs No. 6444. Capacity $\frac{1}{8}$ to $\frac{1}{2}$ inch. Spindle $\frac{1}{2}$ in. x 20-thread. Postpaid. (Shpg. wt. 1 lb. 8 oz.)..... **\$4.00**
J 9 A 2936—Jacobs No. 6325. Capacity 0 to $\frac{3}{8}$ in. Bored $\frac{1}{2}$ -inch straight hole. Postpaid. (Shpg. wt. 1 lb. 8 oz.)..... **\$4.00**
9 A 2937—Jacobs No. 6326. Capacity 0 to $\frac{3}{8}$ inch. Bored $\frac{3}{8}$ -inch straight hole. Postpaid. (Shpg. wt. 1 lb. 8 oz.)..... **\$4.00**
9 A 2938—Jacobs No. 6425. Capacity $\frac{1}{8}$ to $\frac{1}{2}$ in. Bored $\frac{1}{2}$ -inch straight hole. Postpaid. (Shpg. wt. 1 lb. 8 oz.)..... **\$4.00**
9 A 2939—Jacobs No. 6426. Capacity $\frac{1}{8}$ to $\frac{1}{2}$ in. Bored $\frac{3}{8}$ -inch straight hole. Postpaid. (Shpg. wt. 1 lb. 6 oz.)..... **\$4.00**

Jacobs Arbors

K 9 A 2384—Jacobs No. A0025. Fits chuck 9A2936 (Jacobs 6325) and 9A2938 (Jacobs 6425) at left. No. 0 Morse taper on one end, $\frac{3}{8}$ -inch ground straight shank on other. Postpaid. (Shpg. wt. 8 oz.)..... **90c**
9 A 2385—Jacobs No. A0026. Fits chucks 9A2937 (Jacobs 6326) and 9A2939 (Jacobs 6426) at left. No. 0 Morse taper on one end, $\frac{3}{8}$ -inch ground straight shank on other. Postpaid. (Shpg. wt. 8 oz.)..... **90c**
9 A 2386—Jacobs No. A0125. Fits chucks 9A2936 (Jacobs 6325) and 9A2938 (Jacobs 6425) at left. No. 1 Morse taper on one end, $\frac{3}{8}$ -inch ground straight shank on other. Postpaid. (Shpg. wt. 12 oz.)..... **90c**
9 A 2387—Jacobs No. A0126. Fits chucks 9A2937 (Jacobs 6326) and 9A2939 (Jacobs 6426) at left. No. 1 Morse taper on one end, $\frac{3}{8}$ -inch ground straight shank on other. Postpaid. (Shpg. wt. 12 oz.)..... **90c**
9 A 2388—Jacobs No. A0225. Fits chucks 9A2936 (Jacobs 6325) and 9A2938 (Jacobs 6425) at left. No. 2 Morse taper on one end, $\frac{3}{8}$ -inch ground straight shank on other. Postpaid. (Shpg. wt. 14 oz.)..... **90c**
9 A 2389—Jacobs No. A0226. Fits chucks 9A2937 (Jacobs 6326) and 9A2939 (Jacobs 6426) at left. No. 2 Morse taper on one end, $\frac{3}{8}$ -inch ground straight shank on the other end. Postpaid. (Shpg. wt. 14 oz.)..... **90c**

Jacobs Collets

L Replacement collets that fit Jacobs chucks as listed.
9 A 2180—Jacobs No. J61, 0 to $\frac{3}{8}$ inch. Fits chucks 9A2175, 9A2145, 9A2146, 9A2992, left. Postpaid. (Shpg. wt. 4 oz.)..... **70c**
9 A 2181—Jacobs No. J63. Capacity 0 to $\frac{3}{8}$ inch. Fits chucks 9A2176, 9A2147, 9A2993, 9A2936, 9A2937, listed at left. Interchangeable in chucks using 9A2182 below. Postpaid. (Shpg. wt. 8 oz.)..... **\$1.40**
9 A 2182—Jacobs No. J64. Capacity $\frac{3}{8}$ to $\frac{1}{2}$ inch. Fits chucks 9A2177, 9A2149, 9A2938, 9A2939, 9A2999 listed at left. Interchangeable in chucks using 9A2181 above. Postpaid. (Shpg. wt. 8 oz.)..... **\$1.40**

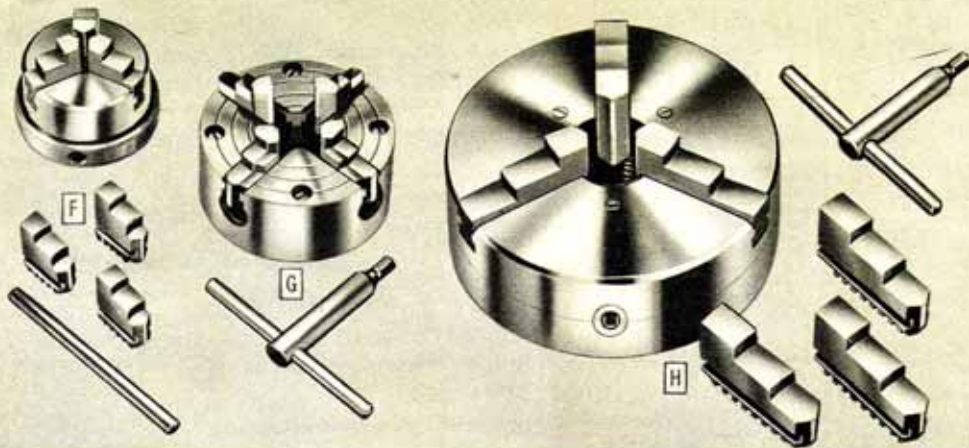
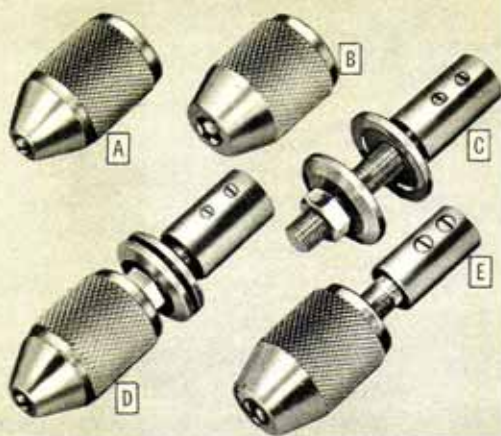

Drill Chucks, Arbors

3-jaw Chucks . . screw-on type

CRAFTSMAN quality. Hardened steel jaws center accurately. Knurled for firm grip. *Check spindle size.*

- A Tapped to fit 1/2-inch x20 thread spindles.
- 9 A 2248—1/4-inch capacity. Shpg. wt. 5 oz. 70c
- 9 A 2243—3/8-inch capacity. Shpg. wt. 12 oz. 90c
- 9 A 2256—1/2-inch capacity. Shpg. wt. 12 oz. 98c

- Tapped to fit 1/2-inch x24 thread spindles.
- 9 A 2130—1/4-inch capacity. Shpg. wt. 5 oz. 70c
- 9 A 2244—3/8-inch capacity. Shpg. wt. 8 oz. 85c
- 9 A 2132—1/2-inch capacity. Shpg. wt. 12 oz. 98c

- B 9 A 2264—CRAFTSMAN deluxe chuck, 3/8-inch capacity. Tapped 3/8-inch x 20 thread. With chuck spanner wrench. Shipping wt. 1 lb. \$1.20

- C 9 A 2164—CRAFTSMAN general purpose Work Arbor. Converts your motor into a grinder, polisher, buffer, etc. Of carbon steel, 4 in. long, 2 3/4 in. spindle has 1/2-in. x 20 thread. Steel flanges for clamping grinding or buffing wheels. Fits 3/8 or 1/2 in. unthreaded shaft. Fastens with 2 set screws. State whether for 1/2 or 3/8-in. spindle. Shpg. wt. 12 oz. 70c

Arbors with 3-jaw, 1/2-inch Drill Chucks

- D 9 A 2151—Chuck and 3/8-in. x 20 thread arbor with steel flanges. Fits 3/8 or 1/2-in. unthreaded straight spindle. Fastens with 2 set screws. State whether for 1/2 or 3/8-in. spindle. Shpg. wt. 1 lb. 10 oz. \$1.45
- E 9 A 2270—CRAFTSMAN deluxe chuck, 3/8-in. capacity; with 3/8-in. x 20 thread arbor. Fits 3/8 or 1/2-in. unthreaded straight spindle. Fastens with 2 set screws. Has chuck spanner wrench. State whether for 1/2 or 3/8-in. spindle. Shpg. wt. 1 lb. 6 oz. \$1.40

CRAFTSMAN quality Lathe Chucks

3-jaw Universal

F CRAFTSMAN. Finest quality in design, materials and construction. Self-centering, lever-operated type . . . has only two main parts, body and scroll. Ideal for production work because of speedy gripping. Accurate within standard chuck tolerances which is approx. .003 inches.

Case-hardened, cold rolled steel jaws; polished steel body and scroll. Knurled rim permits easy hand operation. Body casting is precision threaded to fit directly on spindle. Has two sets of jaws; one for outside and one for inside gripping. Chuck wrench included. In five sizes. Fit lathes with spindle diameters and threadings listed below.

- 9 A 2295—CRAFTSMAN. Fits 3/8-in. by 20-thread spindle. Diameter 2 in. Shpg. wt. 1 lb. 12 oz. \$16.95
- 9 A 2296—CRAFTSMAN. Fits 3/8-in. by 20-thread spindle. Diameter 3 in. Shpg. wt. 3 lbs. 5 oz. \$17.95
- 9 A 2297—CRAFTSMAN. Fits 1-in. by 8-thread spindle. Diameter 4 in. Shpg. wt. 6 lbs. 5 oz. \$22.25
- 9 A 2298—CRAFTSMAN. Fits 1 1/8-in. by 8-thread spindle. Diameter 5 in. Shpg. wt. 10 pounds. \$26.25
- 9 A 02299—CRAFTSMAN. Fits 1 1/2-in. by 8-thread spindle. Diameter 6 in. Shpg. wt. 15 lbs. \$33.95

4-jaw Independent

G CRAFTSMAN. Precision made of finest materials. Body of special alloy steel has deep, wide jaw slots for added strength and greater bearing surface. For average shop needs.

Four reversible jaws, drop forged from a solid bar of special steel, work independently; especially useful for holding irregular shaped pieces. Large diameter jaw screw for extra strength; Acme threaded. T-handle chuck wrench included. Fit any lathe with spindle diameters and threads per inch listed below. In six sizes:

- 9 A 2137—CRAFTSMAN. Fits 3/8-inch by 24 thread spindle. Diameter 3 in. Shpg. wt. 2 lbs. 8 oz. \$7.25
- 9 A 2157—CRAFTSMAN. Fits 3/8-inch by 20 thread spindle. Diameter 3 in. Shpg. wt. 2 lbs. 10 oz. \$7.25
- 9 A 2156—CRAFTSMAN. Fits 3/8-inch by 16 thread spindle. Diameter 4 in. Shpg. wt. 3 lbs. 10 oz. \$8.50
- 9 A 2138—CRAFTSMAN. Fits 1-inch by 8 thread spindle. Diameter 4 in. Shpg. wt. 3 lbs. 12 oz. \$8.50
- 9 A 2139—CRAFTSMAN. Fits 1 1/8-inch by 8 thread spindle. Diameter 6 in. Shpg. wt. 9 lbs. 10 oz. \$15.95
- 9 A 02141—CRAFTSMAN. Fits 1 1/2-inch by 8 thread spindle. Diameter 8 in. Shpg. wt. 25 lbs. \$28.50

3-jaw Universal

H CRAFTSMAN fine quality in precision construction, materials and craftsmanship. 3-jaw, self-centering type. Jaws are controlled by single screw and pinion gear . . . ideal for production work because of their speedy gripping and accurate centering.

Chuck body casting of high strength semi-steel construction. Special alloy metal scroll and alloy steel pinion. Alloy steel jaws are heat treated and hardened; have raised, precision ground steps . . . accurate within standard chuck tolerances. Complete with two sets of jaws (outside and inside). T-handle chuck wrench included.

- 9 A 2148—Fits 1-inch by 8 thread spindle. Diameter 4 inches. Shipping wt. 4 lbs. 8 oz. \$36.50
- 9 A 2150—Fits 1 1/8-inch by 8 thread spindle. Diameter 5 inches. Shipping wt. 6 lbs. 11 oz. \$38.00

Buy it NOW on Sears Easy Terms. See inside front cover.

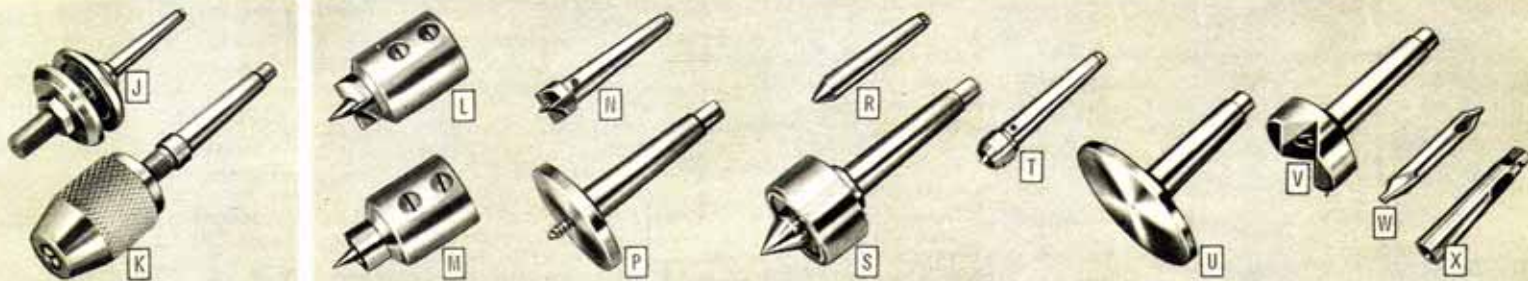

Arbors and Chucks

- J Work Arbors. For mounting drill chucks and holding grinding, buffing and wire scratch wheels, etc. 3/8-in. x 20 thread. Morse taper shank. 2 steel flanges with nut on head end for clamping wheels. 9 A 2117—No. 0 Morse taper. Shpg. wt. 8 oz. 98c
- 9 A 2153—No. 1 Morse taper. Shpg. wt. 9 oz. 95c
- 9 A 2152—No. 2 Morse taper. Shpg. wt. 11 oz. \$1.05
- K Work Arbors with Chucks. 3-jaw, screw-on type chucks, tapped 3/8-inch x 20 thread; 3/8-in. capacity. Have Morse taper, shank end. 9 A 2234—No. 1 Morse taper with chuck and arbor. Shpg. wt. 1 lb. 8 oz. \$1.95
- 9 A 2247—No. 2 Morse taper with chuck and arbor. Shpg. wt. 1 lb. 8 oz. \$1.95

CRAFTSMAN fine quality Lathe Centers and Accessories

- Lathe Centers. Ideal for use on any lathe with 3/8-inch straight spindle. Fasten with 2 set screws. Precision made of ground and hardened steel. Especially designed for maximum strength and rigidity. Has replaceable center point.
- L 9 A 2105—Headstock Spur Center. For driving work mounted between centers. Shipping weight 6 ounces. 90c
- M 9 A 2102—Tailstock Cup Center. Supports work in tailstock. Shipping weight 6 ounces. 90c
- N Spur Centers. Use for wood turning. Accurately ground for perfect fit. Morse taper shank as listed below. 9 A 2108—No. 0 Morse taper. Shipping weight 3 ounces. 70c
- 9 A 2106—No. 1 Morse taper. Shipping weight 4 ounces. 80c
- 9 A 2107—No. 2 Morse taper. Shipping weight 7 ounces. 85c
- P Screw Centers. For facing and hollowing operations. Replaceable center. Morse taper shank as listed below. 9 A 2116—No. 1 Morse taper. Shipping weight 12 ounces. \$1.45
- 9 A 2115—No. 2 Morse taper. Shipping weight 14 ounces. 1.45
- R 60-degree Centers. Morse taper shank as listed below. 9 A 2103—No. 0 Morse taper. Shipping weight 3 ounces. 60c
- 9 A 2110—No. 1 Morse taper. Shipping weight 3 ounces. 65c
- 9 A 2111—No. 2 Morse taper. Shipping weight 7 ounces. 70c

- S Precision ball bearing 60-degree center. (Center point rotates on ball bearing.) Recommended for high speed operations. Morse taper shank as listed below. 9 A 2112—No. 1 Morse taper. Shipping weight 8 ounces. \$2.85
- 9 A 2113—No. 2 Morse taper. Shipping weight 8 ounces. 2.85
- T Tailstock Cup Centers. Supports work in tailstock. Ground and hardened steel with replaceable center point. Morse taper shank as listed below. 9 A 2109—No. 0 Morse taper. Shipping weight 3 ounces. 65c
- 9 A 2100—No. 1 Morse taper. Shipping weight 3 ounces. 75c
- 9 A 2101—No. 2 Morse taper. Shipping weight 7 ounces. 88c
- U 9 A 2187—Drill Pad. Used in tailstock as rigid support for drilling flat or square work in headstock. Steel shank has No. 2 Morse taper. Dia. of face is 3 3/4 in. Shpg. wt. 1 lb. 2 oz. \$1.45
- V 9 A 2114—Crotch Center. Automatically centers round work in tailstock for accurate cross-drilling. V-slot is precision machined. Steel shank has No. 2 Morse taper. Shpg. wt. 1 lb. \$1.45
- W 9 A 2061—Center Drill. Combination drill and countersink. In 1/2 or 3/8-in. size. State size wanted. Shpg. wt. 1 oz. 45c
- X 9 A 2161—Adapter Sleeve. To reduce from No. 2 to No. 1 Morse Taper. Shipping weight 5 ounces. \$1.30

CRAFTSMAN "80" Metal Turning Lathe

REG. U. S. PAT. OFF.

New Design... New Features... Sturdier

- "V" type ways... hardened and ground spindle
- Offset center construction gives increased cutting capacity
- Wide speed range permits wood and plastic turning
- Taper turning easily and quickly accomplished by setting-over tailstock



Without Motor **\$45.00** CASH
\$4.50 DOWN . . ON EASY TERMS

CRAFTSMAN
 THE RIGHT WAY
 TO SAY
**HARDWARE
 AND TOOLS**



6-inch swing . . 12 1/8 inches between centers . . 23 1/16-in. bed

A new complete back-geared screw cutting lathe that will increase tremendously the work you can do in your shop. It is specially designed for precise work such as turning armatures, model making, repair, experimental and tool room work. The speed range . . . 120 to 1325 R.P.M. . . . permits wood and plastic turning. The precision construction in every detail plus the CRAFTSMAN quality features make this lathe a sensational buy!

Offset center construction. Centers offset 1/16 inch back of bed center line increase the lathe capacity; give greater support to compound and keeps pressure of work on tool bit between the ways, helps you when handling larger work.

Sturdy cast iron bed has heavy cast inverted U type ribbing. V-way bed and undercuts machined at same time for better alignment. Removable No. 0 Morse taper centers in headstock and tailstock. Tailstock may be set over 1/4-inch for turning tapers.

Double bearing headstock. Oilite bronze front bearing adjustable. Taper take-up in front spindle bearing adjusts for longer wear, smoother, more accurate operation.

Compound rest and cross feed. Accurately gibbed for wear-take-up. Complete with accessories shown at left. For arbors and chucks to fit above lathe, see pages 24 and 25.

SPECIFICATIONS:

- Swing over bed 6 inches
- Distance between centers 12 1/8 inches
- Spindle: Nose size 1/4 inch—20 thread
Taper No. 0 Morse
Bore 1/4 inch
- Bearings 2 oilite bronze
- Thread range 8 to 96—right or left hand
- Feeds0024, .0039, .0048, .0078
- Back gear ratio 5 to 1
- Compound rest travel 1 3/4 inches
- Cross slide travel 2 3/4 inches
- Tailstock ram travel 1 3/4 inches
- Tailstock set over 1/4 inch
- Motor recommended minimum 1/4 H.P. 1750 R.P.M.
- Machine pulley (included) 3 step "V" type
- Motor pulley (included) 4 step "V" type
- Speeds Six: 120 to 1325 R.P.M.
- Mounting dimensions 21 1/4 x 5 5/8 inches
- Over-all dimensions: Height, 10 3/4 inches; width, 9 3/4 inches; length, 26 3/4 inches.

99 AM 2127—Without motor. Shpg. wt. 58 lbs. **\$45.00**
 99 AM 2128—With 1/4 H.P. 1750 R.P.M. 110-120 volt 60 cycle A.C. split phase sleeve bearing motor. Shpg. wt. 82 lbs. **\$55.50**

6-piece Tool Bit Set . . ground and shaped

\$230
 Set

Six-piece set of 1/4-inch bits of high speed tool steel. Accurately ground to shape and ready for immediate use. Finest materials and workmanship. Good bits for steady production work. Set includes one each of the following: threading bit, left hand facing bit, right hand turning bit, round nose turning bit, right hand facing bit and left hand turning bit.

9 A 2205—Shipping weight 8 ounces. Set of six **\$230**



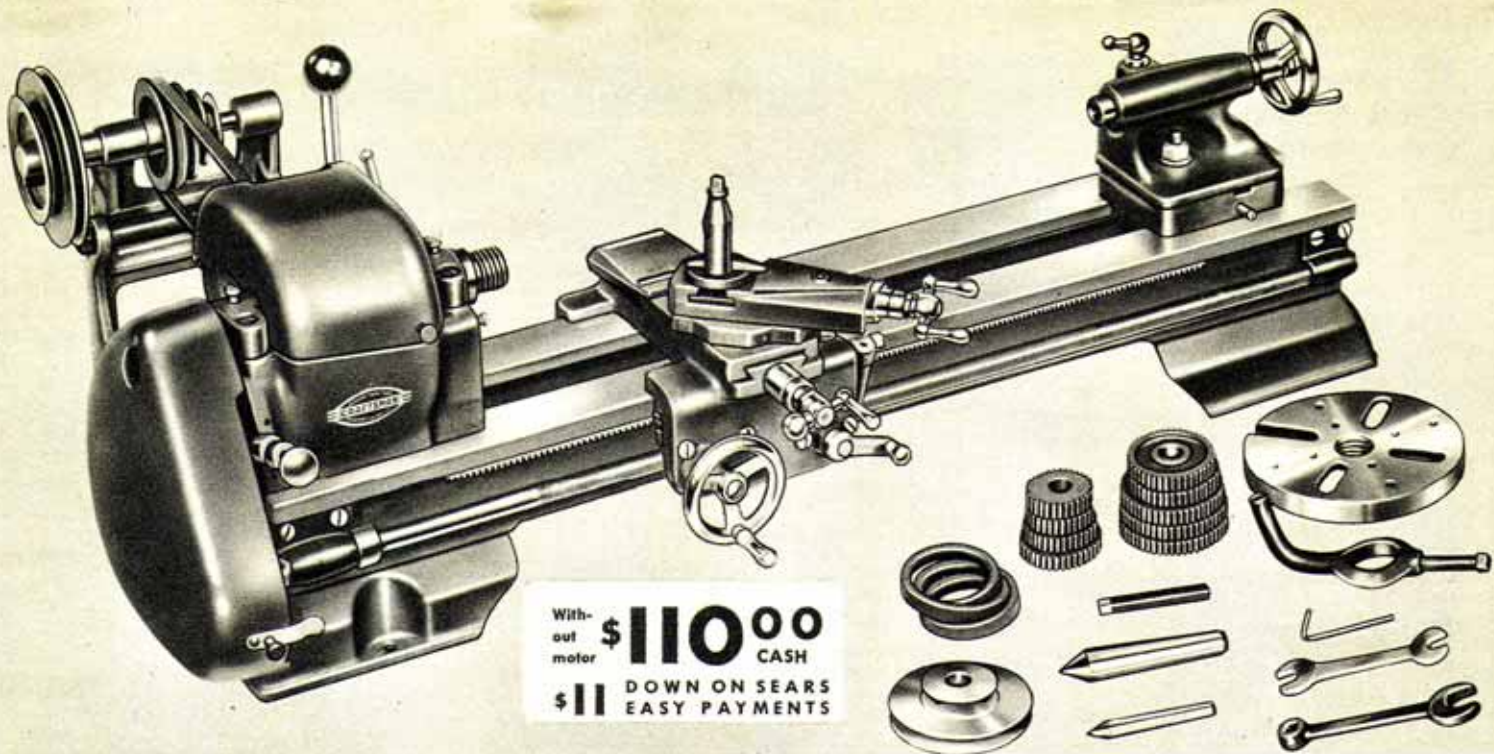

Without motor
\$110.00 CASH
\$11 DOWN ON SEARS EASY PAYMENTS

CRAFTSMAN Model Makers' Lathe

The lathe designed, built and priced just for you; model makers, hobbyists, tool makers, etc. Guaranteed accurate within 1/1000th of an inch at spindle.

Full 6-inch swing... 18 inches between centers... 30 inch bed. Allows you to do wide variety of jobs. Has massive, one-piece, cast semi-steel, precision ground bed. Carriage has hand wheel for manual operation and feed lever for reversible automatic power longitudinal feed. Set-over for taper turning.

Cuts 8 to 96 threads per inch, right or left hand. Back gears give 16 speeds from 54 to 3225 R.P.M. A correct speed for all turning, finishing or polishing. Graduated compound rest swivels 360 degrees.

SPECIFICATIONS:

- Swing over bed..... 6 inches
- Distance between centers..... 18 inches
- Spindle: Nose..... 1 inch-8 thread
Taper..... No. 2 Morse
Bore..... 1 1/2 inch
- Spindle bearing..... 2 oilite bronze; 1 ball thrust
- Thread range..... 8 to 96, right or left hand
- Feeds..... Four: .0024, .0039, .0048 and .0078
- Back gear ratio..... approximately 6 1/2 to 1
- Countershaft and back gear bearings..... 4 oilite bronze
- Swing over carriage..... 4 1/2 inches
- Compound rest travel..... 1 1/4 inches

- Cross slide travel..... 4 3/4 inches
- Tailstock taper..... No. 1 Morse
- Tailstock ram travel..... 1 1/4 inches
- Tailstock set-over..... 9/16 inch
- Motor recommended, minimum..... 1/4 H.P. 1750 R.P.M.

- Machine pulley (included)..... 4 step
- Motor pulley (included)..... 2 step
- Mounting dimensions..... 4 3/4 x 27 1/8 inches
- Over-all dimensions: Height 10 1/4 inches; width 21 1/2 inches; length 33 1/2 inches

Comes with instructions and accessories shown above
99 AM 2048—Without motor. Shipping weight 110 pounds.—\$110.00

Accessories for above lathe to make it more useful



Steady Rest

A Base clamps securely to bed ways. Gives added support needed when turning long pieces. Handles diameters up to 2 3/4 inches. Shipping weight 5 lbs. 8 oz.
9 A 2041.....\$6.50



Follower Rest

B Mounts on back of carriage dovetail slide... moves with cutting tool to provide support needed to prevent deflection when turning long, slender work. Shpg. wt. 3 lbs. 8 oz.
9 A 2042.....\$4.65

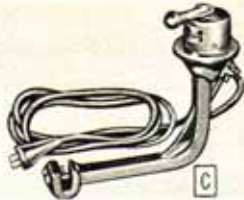

Reversing Switch

C Reverses motor and spindle direction when grinding, polishing, tapping and wood and metal finishing. Not suitable for repulsion-induction motors. Shpg. wt. 5 lbs.
9 A 2039.....\$9.65



Milling Attachment

D Has graduated swivel vise, flat block and V-block for holding cylindrical objects. Vise capacity 2 inches; vertical feed 1 1/4 inches. Graduated swivel. Shipping weight 8 pounds 8 ounces.
9 A 2057.....\$22.50

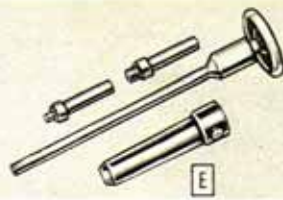

Holding Collet

E This attachment will hold threaded-hole angular milling and keyway cutters and 3/8-inch end mills. Shipping wt. 2 lbs.
9 A 2059.....\$9.25



Tool Holders

Designed to fit 99 AM 2048 Lathe above. Made of special drop forged steel, expertly heat treated and hardened. Accurately machined. Set screws of finest alloy steel. Holders use 3/16-inch tool bits listed at right.

- F** 9 A 2031—Threading Tool. Shpg. wt. 14 oz.\$4.80
- G** 9 A 2033—Straight Tool Holder. No bit. Shpg. wt. 12 oz.\$7.30
- H** 9 A 2034—Right Hand Tool Holder. No bit. Shpg. wt. 12 oz.\$2.30
- J** 9 A 2035—Left Hand Tool Holder. No bit. Shpg. wt. 12 oz.\$2.30
- K** 9 A 2037—Cut Off Tool. Shpg. wt. 14 oz.\$2.90
- L** 9 A 2036—Knurling Tool. Has medium knurls. Shpg. wt. 14 oz.\$5.60

Formed Tool Bit Set

M Six-piece set of 3/16 inch tool bits. Made of high speed tool steel. Accurately ground to shape, ready for use. Good for production work. Set includes one each of the following: threading bit, left hand facing bit, left hand turning bit, right hand turning bit, right hand facing bit and round nose turning bit.
9 A 2043—Shpg. wt. 5 oz.\$2.30

Tool Post Set

N Ideal for precision boring jobs requiring rigid tool mounting. Tools mount directly in tool post. Made of high speed tool steel. Set includes the following: four boring bars, internal threading tool, external threading tool, external turning tool and set of tool post spacers for height spacing.
9 A 2038—Shpg. wt. 14 oz.\$8.25

Buy your Power Tools on Sears Easy Terms... only 10% down... balance monthly. See inside back cover for details

CRAFTSMAN Metal Lathe . . .

REG. U. S. PAT. OFF.

Lathe Manual, containing 234 pages of sound and practical explanations of metal lathe operations and construction, is included with these CRAFTSMAN metal turning lathes.



Accessories for metal lathe shown above

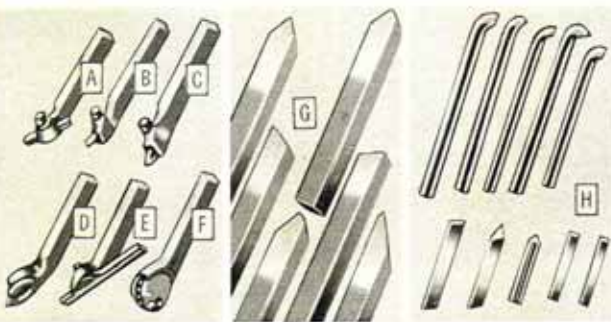

Tool Holders

Steel forgings; expertly made and carefully finished. For use with $\frac{1}{4}$ -inch tool bits shown below. Shanks are $\frac{3}{8}$ -inch high; $\frac{3}{8}$ -inch wide. Shipping weight each 2 pounds.

- | | |
|--|---|
| A 9 A 2194—Offset, left. \$2.25 | B 9 A 2198—Threading. . . . \$4.95 |
| B 9 A 2192—Offset, right. 2.25 | E 9 A 2200—Cut-off. 3.15 |
| C 9 A 2196—Straight. . . . 2.25 | F 9 A 2202—Kaurling tool. . 5.95 |

6 Formed Tool Bits

Handy bits that are ground ready to use. $\frac{1}{4}$ -inch size. Fit the tool holders listed above. Shipping weight 8 ounces. Set includes: Threading bit, Round nose turning bit, Left hand facing bit, Right hand facing bit, Right hand turning bit, Left hand turning bit.

9 A 2205—Set of 6 tool bits. **\$2.30**

Tool Post Tool Set

Set includes 4 boring tools ($\frac{3}{16}$, $\frac{1}{4}$, $\frac{5}{16}$ and $\frac{3}{8}$ inch); $\frac{1}{4}$ -inch inside threading tool; $\frac{3}{8}$ -inch turning tool; $\frac{3}{8}$ inch threading tool and set of tool post spacers.

9 A 2189—Shipping weight 2 pounds. **\$8.50**

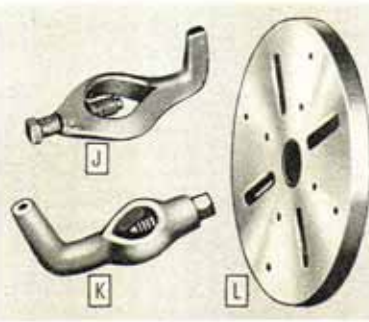

Lathe Dog

- J Malleable iron. Holds work firmly. Choice of four sizes: $\frac{1}{2}$, $\frac{3}{4}$, 1, or $1\frac{1}{4}$ -in. State size. 9 A 2078—Shipping weight 8 oz. **55c**
- K Forged steel. Heat treated hardened set screw. Choice of four sizes. State size. 9 A 2183—Shipping weight each, 1 pound. $\frac{1}{2}$ inch. **92c** 1 inch. **\$1.05**
 $\frac{3}{4}$ inch. **\$1.05** $1\frac{1}{2}$ inch. **1.20**

Face Plates

- L For use on lathe with $\frac{1}{2}$ -in. 20-thread spindle. 9 A 2468—4-inch. Shpg. wt. 3 lbs. **\$3.70**
 For use on lathe with $\frac{3}{4}$ -in. 16-thread spindle. 9 A 2469—4-inch. Shpg. wt. 3 lbs. **\$3.70**
 For use on lathe with 1-in. 8 thread spindle. 9 A 2470—4-inch. Shpg. wt. 3 lbs. **\$3.70**
 For use on lathe with $1\frac{1}{2}$ -in. 8-thread spindle. 9 A 2471—4-inch. Shpg. wt. 3 lbs. **\$3.70**
 9 A 2475—8-inch. Shpg. wt. 6 lbs. **5.50**

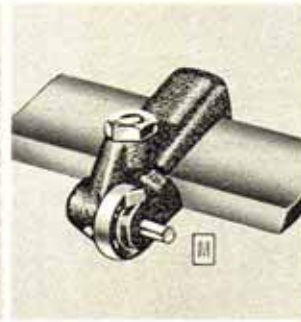

Micrometer Carriage Stop

M Has adjustable micrometer stop to indicate stopping place for carriage in boring or facing to a given depth; cutting off at a given point; duplicating longitudinal cuts; and laying out work on a cylindrical surface. Clamps on front of bed way. Fits CRAFTSMAN lathes listed at top right and on bottom of opposite page.

9 A 2185—Shipping weight 1 lb. **\$5.25**



Mica Undercutter

N Easily and quickly fastens to the back of carriage. Screw feed regulates height of cutter and carriage feed moves cutter into commutator slot. For use on 110-120 volt 25-60 cycle A.C. or D.C. Complete with motor, switch, cord, set of 5 undercutting saws. Fits all CRAFTSMAN lathes listed at top right and on bottom of the opposite page.

9 A 2989—Shipping weight 10 lbs. **\$41.50**

Guaranteed accurate to one-thousandth inch

- Famous Timken tapered roller bearings maintain spindle alignment and absorb radial and thrust loads
- Guards completely cover headstock and motor pulley

- Thread range from 4 to 96 threads per inch, either right or left hand (standard) Metric .5 to 7.0 m.m.
- Reversible power cross feed makes facing work easier

99 AM 2075 **\$215⁰⁰** CASH **\$21.50** DOWN . . ON SEARS EASY PAYMENTS

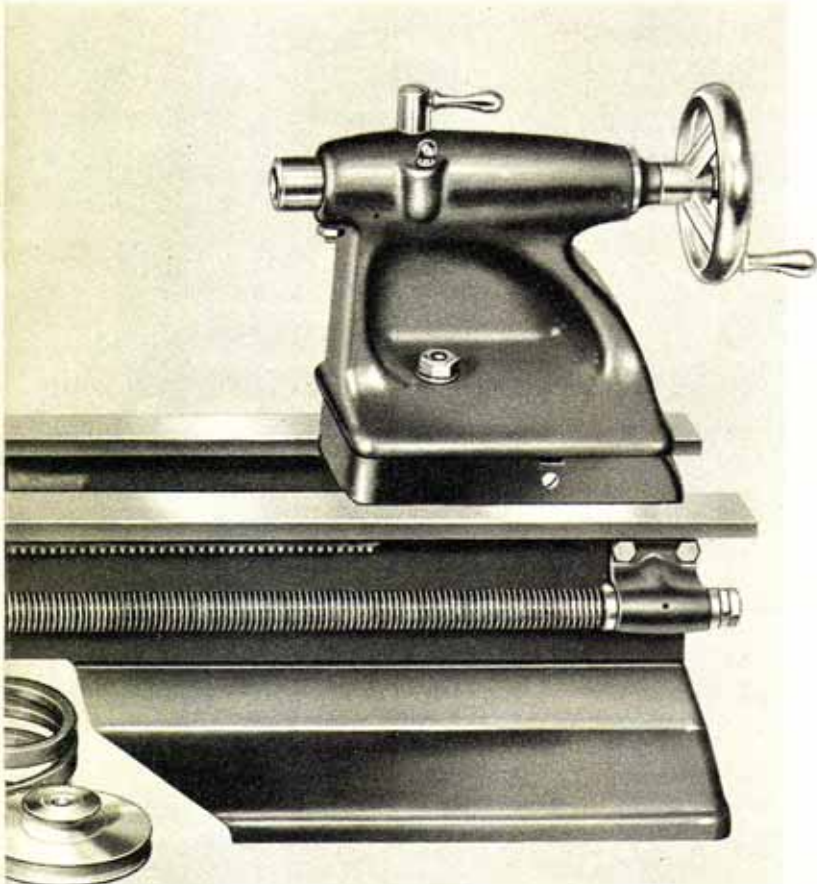

The ability of this CRAFTSMAN metal turning lathe to cut accurately to 1/1000th inch even after years of use is the result of precision construction and expert design. It's outstanding in workmanship, materials, versatility and price.

Famous Timken tapered roller bearings in headstock assure smooth, fast cutting even at high spindle speeds. Maintain spindle alignment and absorb the radial and thrust loads. Rugged massive construction.

Reversible power cross feed and longitudinal feed permits you to do your facing work accurately and automatically. Simple and easy to operate. Tailstock has set over for taper turning.

Quick-change countershaft. Guards completely cover headstock and motor driven pulleys. Hinged for quick speed changes. Powered with V-belt drive. Keeps lathe clean; helps prevent accidents. Check the following specifications.

SPECIFICATIONS:	99 AM 2075	99 AM 2079
• Swing over bed	12 3/4 inches	12 3/4 inches
• Distance between centers	24 inches	36 inches
• Spindle, Nose size	1 1/2 in.—8 thread	1 1/2 in.—8 thread
• Taper	No. 2 Morse	No. 2 Morse
• Bore	1 3/4 inch	1 3/4 inch
• Spindle bearings	2 sets Timken roller	2 sets Timken roller
• Thread range	4 to 96 R.H. or L.H.	4 to 96 R.H. or L.H.
• Feeds	.0024; .0035; .005; .0071; .0087	
• Back gear ratio	Approx. 6 to 1	Approx. 6 to 1
• Countershaft and back gear bearings	4 oillite bronze	4 oillite bronze
• Swing over carriage	8 3/4 inches	8 3/4 inches
• Compound rest travel	2 3/8 inches	2 3/8 inches
• Cross feed	Reversible; power feed	Reversible; power feed
• Cross slide travel	6 1/2 inches	6 1/2 inches
• Tailstock taper	No. 2 Morse taper	No. 2 Morse taper
• Tailstock ram travel	2 3/4 inches	2 3/4 inches
• Tailstock set over	3/4 inch	3/4 inch
• Machine pulley (included)	.6 inch 4 step	.6 inch 4 step
• Motor pulley (included)	.4 1/2 inch 2 step	.4 1/2 inch 2 step
• Speeds	Sixteen 28 to 2072 R.P.M.	28 to 2072 R.P.M.
• Mounting dimensions	6 3/4 x 35 1/4 in.	6 3/4 x 47 1/4 in.
• Over-all dimensions, Height	20 inches	20 inches
• Width	25 3/4 inches	25 3/4 inches
• Length	45 inches	57 inches

Comes with tool post wrench, threading gears and 234-page lathe manual.
 99 AM 2075—Shipping weight 275 pounds \$215.00
 99 AM 2079—Shipping weight 295 pounds \$236.00

For arbor see page 24 . . . For chucks see page 25

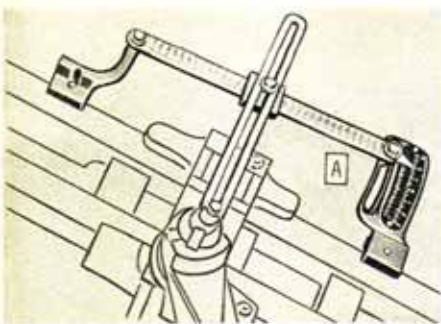

Taper Attachment

A An accurate taper attachment that's easily and quickly installed . . . simple to operate. You don't have to move the tailstock out of alignment when you use this attachment. Duplicate tapers can be cut accurately on pieces of different lengths. Internal boring work can be done as easily as external work. The index plate is graduated 7° and 3 in. both sides of the center line. Equivalent to taper of 2 1/4 in. per foot. Designed to fit lathes listed at top and bottom of this page.
 9 A 2984—Shipping weight 10 pounds \$25.50



Reversing Switch

B Drum type reversing switch that is essential for grinding, tapping and all types of fine metal and wood finishing. The reversing motor reverses direction of lathe spindle. (Note: Do not use with repulsion—induction motors.) Comes with cord and plug.
 9 A 2983—Shipping weight 5 pounds \$10.90



Steady Rest

C The sturdy solid brass jaws give rigid support to insure accuracy in turning, boring, and threading on your lathe. Especially useful for accuracy when turning, boring or threading long slender pieces. Clamps securely and rigidly to the bed ways. Has a capacity up to 2 3/4 inches. Comes complete with extra jaws. Ready for use.
 9 A 2050—Shipping weight 7 pounds \$8.50



Follower Rest

D Here's the accessory that will give you the necessary support for jobs that require a long cut on a small diameter. Enables you to do much more accurate and precise work. It fastens securely to the back of the carriage dovetail slide . . . follows the cutting tool. Essential for long slender pieces. Very convenient and easy to use.
 9 A 2988—Shipping weight 4 pounds \$6.25

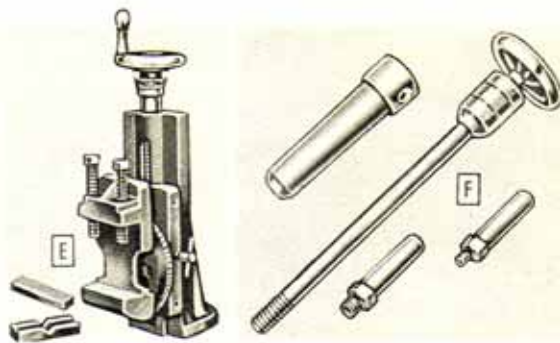

Milling Attachment

E Complete as shown, with graduated swivel vise. V-block for holding cylindrical objects. Vise capacity 2 3/4 inches. Vertical feed 2 3/4 inches. Cross feed 5 inches. Has graduated micrometer feed screw. Angular swivel accurately graduated in degrees. Easily and quickly mounted in place of compound rest.
 9 A 2987—Shipping weight 16 pounds \$27.50

Holding Collet

F Ideal for use on straight shank milling cutters. Furnished with two arbors, one to take threaded hole angular cutters, etc. Hand wheel type. Provides excellent means of holding milling cutters firmly and rigidly. Particularly valuable to those who are required to use many types of cutters frequently.
 9 A 2994—Shipping weight 3 pounds \$9.90
 9 A 2985—Four bushings for use with 3/4, 1/2, 3/8 and 5/16 inch end mills. Shipping weight 4 oz. \$2.50

All the accessories shown above fit CRAFTSMAN lathes numbers 2065, 2067, 2069, 2071, 2073, 99AM2075, 2077, and 99AM2079

CRAFTSMAN Oxy-Acetylene Welders

Only \$6.50 down on Easy Terms . . . Welders' Handbook included

Farmers! Factories and industrial shops! Garages, repair and welding shops! Scrap yard operators! Maintenance men! Just what you've been looking for . . . a quality-built oxy-acetylene welding outfit at a price you can afford. Soon pays for itself! Farmers, you can save money, make real profits, doing professional type welding for yourself and your neighbors.

It's easy to learn how to do welding, cutting, brazing and soldering. Informative Welders' Handbook, included with outfit, tells you what to do and shows you how to do it. A little practice gives you the skill needed to do a real job.

Oxy-acetylene welding outfit is readily portable. You can use it anywhere, even in areas where electrical power is not available or accessible. Make farm repairs in the field . . . no need to bring work into shop. Consult your classified telephone directory for nearest supplier of oxygen and acetylene.

Guaranteed quality! Actually triple tested to highest standards! (1) Every part individually factory tested many times during construction . . . and factory approved before shipment. (2) Tested and approved by Underwriters' Laboratories, Inc. (3) Tested and approved by Sears own Merchandise Testing Laboratory. In addition, these outfits are approved by Associated Factory Mutual Insurance Company.

You know CRAFTSMAN oxy-acetylene welding outfits are safe. All parts coming into contact with gas are made of SOLID brass or bronze. All joints are ground and hand fitted to eliminate danger of leaks. Regulators are equipped with patented safety pressure-relief devices. Exclusive balanced-pressure non-flash mixer is located beyond the head of the torch and outside of the torch handle for safety. Possibility of "flash-back" and burning on interior of torch has been minimized. No doubt about it, there's real super-quality built into every part of this outfit!

Heavy duty construction throughout! Made to handle toughest jobs! 17 3/4-inch bronze non-flash torch with mixer and 6-inch gooseneck. Gooseneck is bronze drop forging . . . will not bend. Forged solid-bronze-bodied regulators have two pressure gauges with brass cases: 0 to 80 and 0 to 3000-pound oxygen regulator, and 0 to 80 and 0 to 500-pound acetylene regulator.

Also included in this outfit! Five wide-range tips of one-piece solid drawn copper, highly polished (AA-1, AA-2, AA-3, AA-4, and AA-5); two 12 1/2-foot lengths of 3/4-inch high-pressure hose, tested to 800 lbs. per square inch; assorted welding rods; flux; lighter; two wrenches; 50-mm. welders' goggles and 224-page Welders' Handbook. Welder may be used as cutting torch, using 9 A 5444 attachment. See opposite page.

99 A 05442—As described above. Shpg. wt. 28 lbs. . . . \$65.00
9 A 5410—Flux only. Can be used for all types of acetylene welding. Shipping weight 1 pound 3 ounces. 1-lb. can. . . . \$6.50
9 A 5411—224-page Welders' Handbook. Helpful; easy to understand. Postpaid. (Shipping weight 1 lb.) . . . \$3.50

\$65.00 CASH
\$6.50 DOWN . . . ON TERMS

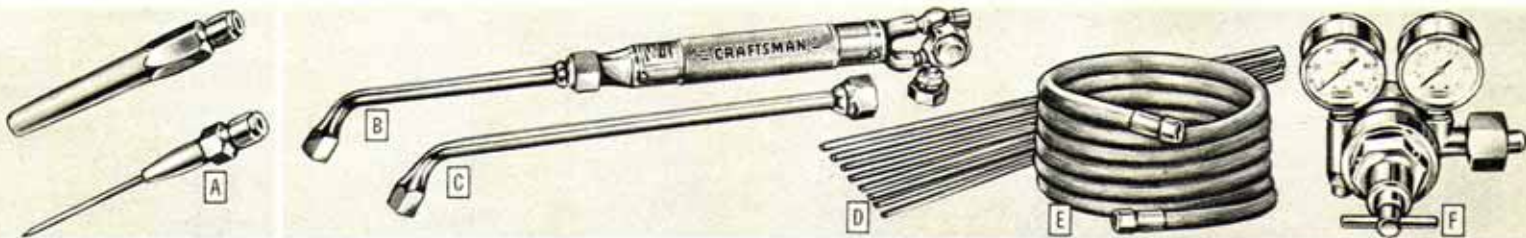
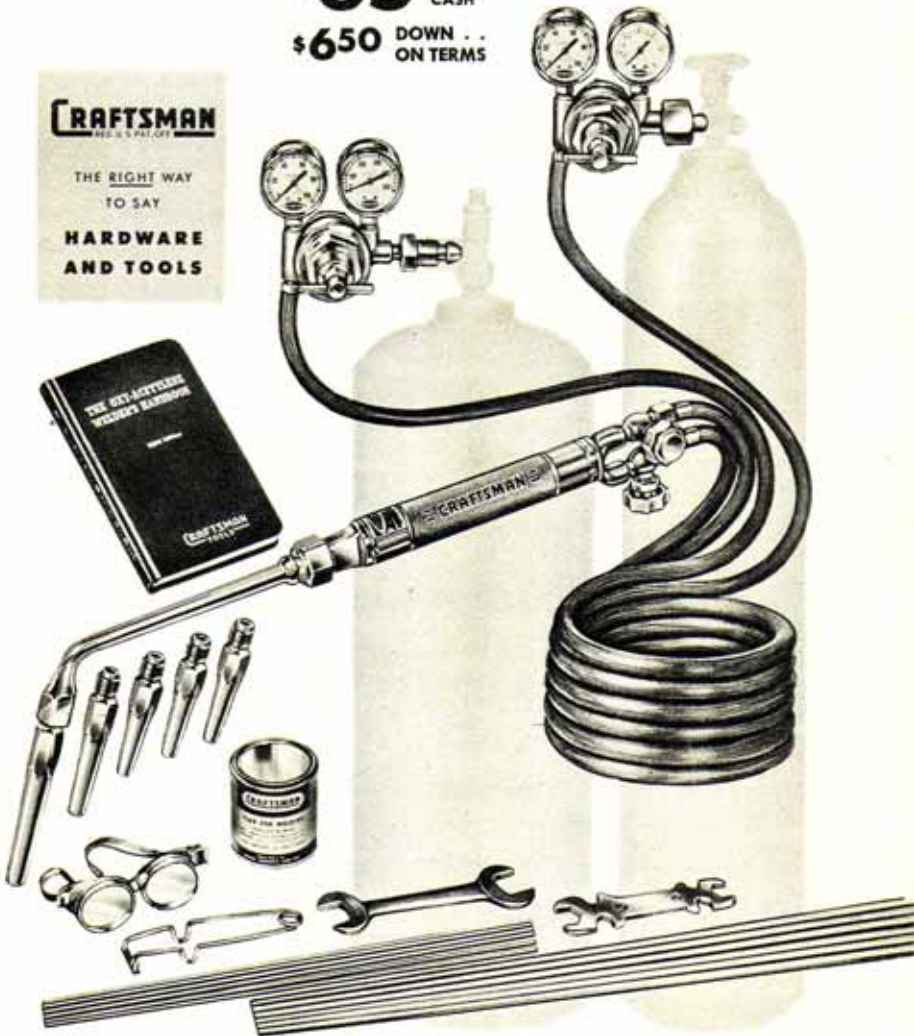

Welding Tips

A CRAFTSMAN. As supplied with above welding outfit. Interchangeable. Made by new "swaging" process from heavy, one-piece solid drawn pure copper containing minimum of lead and tin. Withstands extremely high (6000°F) oxy-acetylene flame temperatures. Highly polished. Shipping weight 4 oz. each. State size wanted.
9 A 5441 Each \$1.65

Size	Welding capacity, in.
AA-0	For soldering . . .
AA-1	3/16 to 1/2 in.
AA-2	3/16 to 3/8 in.
AA-3	3/8 to 1/2 in.
AA-4	1/2 to 3/4 in.
AA-5	3/4 to 1 in.
AA-6	1/2 to 3/4 in.
AA-7	3/4 to 1 inch.
AA-8	1 inch and up

Welding Torch

B CRAFTSMAN. Model, A. 17 3/4 inches long. Bronze non-flash torch with 6-inch gooseneck mixer. Gooseneck is solid bronze drop forging . . . will not bend. Permits you to cut steel, using 9 A 5444 cutting attachment, shown and described on the opposite page. Shipping weight 3 pounds.
9 A 5429 Each \$16.50

Mixing Chamber

C CRAFTSMAN. 12 inches long. Pro-vides the longer mixing section that must be used when using the 9 A 5441 welding tips, sizes AA-6, AA-7 or AA-8, listed at the left. Solid drop forged bronze construction. Gooseneck type. Shpg. wt. 12 oz.
9 A 5443 Each \$6.25

Welding Rods

D CRAFTSMAN. 90 assorted rods. A complete selection of rods that permits you to do oxy-acetylene welding on bronze, cast iron, aluminum and mild steel. For most repair and production work, welding rod metal should be same as or similar in characteristics to metal being welded. (For example, mild steel rods on steel).
This assortment includes: four 1/2x18-in. Tobin bronze rods; four 3/8x18-in. Tobin bronze rods; thirty 3/32x18-in. mild steel rods; twenty-two 1/2x18-in. mild steel rods; eight 3/8x18-in. mild steel rods; four 3/16x18-in. drawn aluminum rods; and seven 3/4x24-in. cast iron rods. Shipping weight 11 lbs.
9 A 5440—90 rods. \$5.25

1/4-inch Hose

E CRAFTSMAN. Tested to 800 lbs. 12 1/2-ft. per square inch. Working pressure 200 lbs. 3/4-inch inside diameter. One-braid construction with three tough layers. Rayon cord reinforcement stronger than usual cotton hose yarn. Super tough, heat and abrasion-resistant Neoprene cover. Threaded brass connectors. State length wanted. 12 1/2 or 25-ft.
9 A 5437—Green Oxygen Hose. 12 1/2-foot length. Shpg. wt. 1 lb. 13 oz. \$1.80
25-foot length. Shipping weight 4 pounds. . . . \$2.95
9 A 5438—Red Acetylene Hose. 12 1/2-foot length. Shipping wt. 1 lb. 13 oz. \$1.80
25-ft. lgh. Wt. 4 lbs. . . . 2.95

Gas Regulators

F Oxygen Regulator. \$1750
2 gauges: 0 to 80 and 0 to 3000 lbs. Pressure indicator. Shpg. wt. 4 lbs.
9 A 5430 \$17.50
Acetylene Regulator. 2 gauges: 0 to 80; 0 to 500-lb. pressures. Shpg. wt. 4 lbs.
9 A 5431 \$16.50
High Pressure Oxygen Regulator. (Not illus.) Similar to 9 A 5430 above but with 0 to 300 and 0 to 3000 lb. gauges. Shpg. wt. 3 lbs.
9 A 5448F \$17.50
Adapters. (Not illus.)
9 A 5413—Adapter for Airco, Commercial or Searchlight tanks. Shipping weight 5 ounces. . . . \$1.45
9 A 5414—Adapter for Prest-O-Lite auto lighting tanks. Shpg. wt. 5 oz. \$1.65



Welding Needs . . . Body and Fender Tools

Cutting Attachment

A CRAFTSMAN replaces mixer on 99 A 05442 outfit on opposite page. One B-3 tip, wrench and instructions included. 9 A 5444—Shipping weight 3 pounds 6 ounces. . . . \$16.50

Cutting Tips

B CRAFTSMAN, For above cutting attachment. Shipping weight 6 oz. each. State size when ordering.

Size	Cuts steel	Size	Cuts steel
B-1	up to 3/8 in.	B-4	1 1/2 to 4 in.
B-2	3/8 to 1/2 in.	B-5	4 to 6 in.
B-3	1/2 to 1 1/2 in.		

Brazing Outfit

C CRAFTSMAN, Use with Prest-O-Lite cylinders. Operates on acetylene only, requires pressures up to 4 lbs. for largest tips.

Outfit includes: Handle; three heating tips; soldering copper; paint burning tip; tank connection; tip cleaner; 5 feet of rubber hose; instructions. 9 A 5446—Shpg. wt. 2 lbs. \$6.95

CRAFTSMAN Air Hose

D Sensational post-war improvements give this hose super-strength. Superbly made of three tough layers . . . (1) Special rubber inner tube . . . (2) New rayon cord reinforcement . . . TWICE as strong as ordinary hose yarn . . . (3) new super tough Neoprene cover gives greater resistance to sun, oil, chemicals, abrasion, etc. than hose with old-style rubber covers.

Ideal for use with all pneumatic tools, for air lines on spraying equipment, for tire inflation, for cleaning with compressed air, for use wherever air or non-corrosive gas is conducted. With standard brass couplings.

9 A 1875—15-foot lengths. 3/4-inch inside diameter. Shipping weight 1 pound 12 ounces. . . . \$1.89

9 A 1876—25-foot length. 5/16-inch inside diameter. Shipping weight 4 pounds 8 ounces. . . . \$2.98

9 A 1878—Male coupling for joining two or more lengths of above hose. Shipping weight 3 oz. . . . 17c

Also available by the foot without coupling. Any desired length up to 500 ft. in one piece. State length wanted.

Catalog number	Inside diameter	Shpg. wt. per foot	Price per foot
99 A 08800	3/8 in.	.2 ounces	10c
99 A 08801	1/2 in.	.2 ounces	12c
99 A 08802	5/8 in.	.3 ounces	13c
99 A 08803	3/4 in.	.3 ounces	14c

CRAFTSMAN Pneumatic Body and Fender Set

E Built for extra heavy duty, continuous service. Save up to 70% of time ordinarily needed on body, fender and sheet metal work. Pneumatic hammer has drop forged steel body; piston of ball bearing steel. Gleaming chromium plated finish.

Check these four outstanding features of this tool: (1) *It's air lubricated . . .* needs no oil for lubrication. Free-floating piston actually glides on film of air, keeping hammer cool and clean. (2) *No delicate valves to pamper.* Dirt and scale which would clog ordinary air hammer blow out through large holes and exhaust port. (3) *"Easy Control" lever.* You can control pressure, speed and power without changing hand position. (4) *Safer because tool can't accidentally fly out of gun with tool off work.* No beehive spring. Use 90-lb. air supply at 10 C.F.M.

Set includes: Two 1 1/4-inch tubular steel arms (one 20x23 in.; other 18x30 in.); 6 3/4-in. long pneumatic hammer; one upper dolly; two lower dollies. With instructions. 99 A 02510—Pneumatic Body and Fender Set. Shipping weight 33 pounds. . . . Set \$76.95

CRAFTSMAN Air Hammer and Chisels

F Built extra heavy duty for steady production work. Simple, compact. Drop forged steel body; piston of super-tough ball bearing steel. All working parts are heat treated and hardened.

Air lubricated . . . needs no oil for lubrication. Piston glides smoothly, easily. Frankly, we believe it's the finest and most durable air-hammer on the market.

3200 power packed strokes per minute! Plenty of power for chiseling, scaling, metal forming and finishing, removing paint, carbon, rust, etc. Efficient one-hand trigger control. Special friction collar keeps tools from flying out of gun accidentally. Length 7 inches. Uses 90-lb. 10 C.F.M. air supply. Chromium plated.

9 A 2500—Air Hammer only. Shipping weight 3 pounds 12 ounces. . . . \$31.95
CRAFTSMAN Air Hammer Chisels for above. Heat treated alloy steel; hammer-forged. Average length about 7 inches. Buy a complete set for your shop!

(G) 9 A 2501—1 1/4-inch Scaling or Goo Chisel. Shpg. wt. 12 oz.	\$1.39
(H) 9 A 2502—3/4-inch Chipping Chisel. Shpg. wt. 12 oz.	1.39
(J) 9 A 2503—3/4-inch Cape Chisel. Shpg. wt. 12 oz.	1.39
(K) 9 A 2504—3/4-inch Round Nose Cape Chisel. Shpg. wt. 12 oz.	1.39
(L) 9 A 2505—3/4-inch Round Nose Cape Chisel. Shpg. wt. 12 oz.	1.39
(M) 9 A 2506—3/4-inch Diamond Point Chisel. Shpg. wt. 12 oz.	1.39
9 A 2507—Set of one each of six chisels above. Shpg. wt. 4 lbs. 4 oz.	7.95

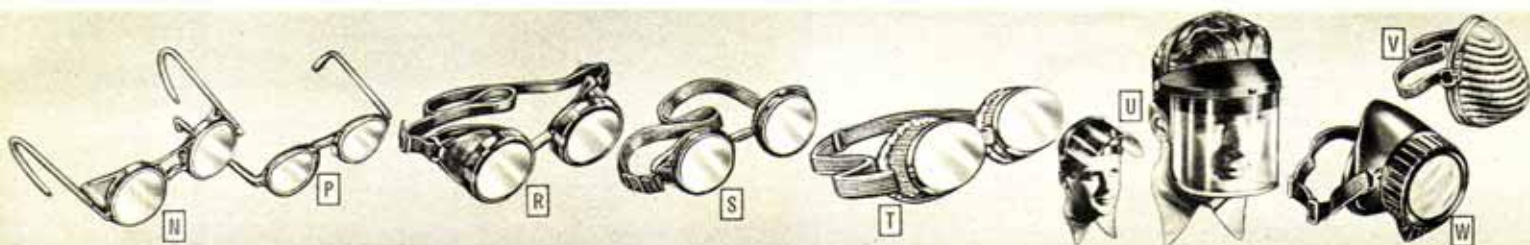

Spectacle type Safety Goggles

N With side shields. For grinding, chipping and hazardous work. Both frontal and side protection. Ample ventilation minimizes fogging. Non-corroding frame; wire mesh side shields. Insulated temple pieces. Heat and perspiration resistant. Adjustable nose piece. Clear, hardened, ground 50-mm. lenses. 28 A 6070—Shipping weight 8 ounces. . . . \$2.19

P Lightweight type. No side shields. Crystal clear 44-mm. flat lenses. Full angle vision. Non-inflammable plastic frame. Wire cored padded temples. 28 A 6067—Shipping weight 5 ounces. . . . \$1.69

Industrial type Safety Goggles

R For chipping and grinding. Eye protection from flying particles coming from all directions. Clear 50-mm. lenses hardened and ground. Wide angle vision. Composition frame; adjustable headband. 28 A 6060—As described. Shipping weight 9 oz. . . . \$2.29
 28 A 6061—Similar to above, but larger, to fit over regular glasses. Shipping weight 12 oz. . . . 2.49

Replacement 50-mm. Lenses. Not shown. Clear glass, hardened and ground. For 28 A 6070, 28 A 6060 and 28 A 6061. 28 A 6088—Shipping weight 3 oz. per pair Pair 89c

Welders' Goggles

S Shade 5 lenses. For light acetylene welding, cutting. Elastic headband; adjustable bridge. Ventilated side shields; no fogging. Screw caps for changing lens or cover glass. 28 A 6053—Shpg. wt. 4 oz. . . . \$2.39

Over-spectacle style. Worn over regular glasses. Similar to 28 A 6053. 28 A 6054—Shpg. wt. 12 oz. . . . \$2.69

Extra 50-mm. Filter Lenses for above. No. 4 density. For average acetylene welding, cutting, brazing, etc. 28 A 6055—Shpg. wt. 3 oz. . . . Pair 79c

No. 6 density. Extra dark. For heavy acetylene welding, cutting, etc. 28 A 6057—Shpg. wt. 3 oz. . . . Pair 79c

T Dust and Wind Goggles. Cloth sides filter out dust, prevent fogging. Chenille bound edges. Shatter-proof glass lenses. 28 A 6058—Shpg. wt. 4 oz. . . . \$1.45

Similar to above. Plain glass lenses. 28 A 6062—Shpg. wt. 4 oz. . . . 65c

Plastic Face Shield

U Protects eyes and face. Adjustable. Metal-bound window of non-inflammable plastic snaps onto shield. Sweatband; eye shade. 10 3/4 x 6 in. 28 A 6085—Shipping weight 1 lb. . . . \$2.29
 28 A 6086—Extra Window for above. Shpg. wt. 8 oz. . . . 89c

Low-cost Respirator

V Protects against pollens and dust from processing wood, grain, stone and metal. Comfortable molded rubber frame. 28 A 6087—As described above. Shpg. wt. 8 oz. . . . \$1.89

Industrial Respirators

W For all dust hazards—mineral, agricultural, etc. See below for fumes and vapors. Positive protection. Air-tight fit. Valve can't stick open. Sanitary, easy to clean. Pliable, non-irritating rubber face mask. Easily replaceable filter. 28 A 6073—As described above. Shpg. wt. 12 oz. . . . \$3.69
 28 A 6074—Extra Filter for above. Shpg. wt. 5 oz. . . . \$1.10

For low concentration fumes and vapors such as paint spraying, dry cleaning, gasoline, benzene, etc. Design similar to 28 A 6073 described and shown above. Easily replaceable filter included. 28 A 6081—As described above. Shpg. wt. 12 oz. . . . \$3.59
 28 A 6084—Extra Filter for above. Shpg. wt. 5 oz. . . . Each 79c

WARNING: Respirators cannot and should not be used as gas masks.



CRAFTSMAN
REG. U.S. PAT. OFF.

Twin Carbon Torch

Industrial type. Doubles usefulness of any A.C. arc welder. Faster, easier, better brazing, soldering, heating. Ideal for work on thin metals. Lightweight. With cables, carbons, instructions. **\$15.95**

9 A 2007—Length 15 $\frac{1}{4}$ inch. Shpg. wt. 4 lbs. 6 oz. \$15.95

Cored Carbons for Twin Torches

Catalog number	Diameter	Length	Shipping weight	Each
9 A 2020	$\frac{3}{16}$ inch	6 inches	2 ounces	10c
9 A 2021	$\frac{1}{8}$ inch	6 inches	2 ounces	12c
9 A 2022	$\frac{5}{16}$ inch	6 inches	2 ounces	15c



CRAFTSMAN Electrode Holder

A Fully insulated. Light in weight. Rods quickly changed. For welders with capacity of 300 amperes or less. 9 inches long. **\$2.98**

9 A 2006—Shipping weight 1 pound. \$2.98

Dependable Welding Helmets

B One piece seamless vulcanized fiber construction. Shaped to fit head contour. Fiber head band adjustable over wide range of sizes. No metal touches head. Friction joint adjustable from outside for free-floating action. Bakelite glass holder. 2x4 $\frac{1}{2}$ inch clear cover glass provided. Filter lens not provided. See below. **\$7.70**

9 A 1324—Shipping weight 2 lbs. 6 oz. \$7.70

C Streamlined fabricated fiber construction. **\$6.25**

Helmet has automatic spring snap for "off" and "on" positions. Black fiber headband with genuine leather sweatband. Size adjustable over wide range. No metal touches head. Convenient glass holder keeps cover glass and filter lens in place yet readily removable. 2x4 $\frac{1}{2}$ inch clear cover glass supplied; filter lens not included. See below. **\$6.25**

9 A 1323—Shipping weight 2 lbs. 9 oz. \$6.25

D Fabricated fiber construction. **\$3.45**

Adjusts to fit head size. Can be thrown back without removing from head. Friction joint between headband and helmet make helmet readily adjustable and secure in both "on" and "off" positions. Clear cover glass and No. 10 density filter lens provided. Both are 2x4 $\frac{1}{2}$ -inch size. Note our low price! **\$3.45**

9 A 1326—Shipping weight 2 lbs. 8 oz. \$3.45

Extra Filter Plates and Cover Glass. Not illustrated. For arc welding use. Size 2x4 $\frac{1}{2}$ inches. Fit almost all helmets. Shipping wt. of each is 5 oz.

9 A 1327—No. 10 shade Filter Plate. For 75 to 250 ampere welding work. **87c**

9 A 1328—No. 12 shade Filter Plate. For 250 ampere or over welding work. **87c**

9 A 1329—Clear Cover Glass. **.6c**

Electrode Assortment

E CRAFTSMAN. Handy 20-pound assortment of welding rods for general utility work. About 380 rods in all! Assortment includes types and sizes for most general purpose welding jobs. For use with A.C. or D.C. welders (D.C. reverse polarity). Assortment includes: Rods for mild steel welding; 2 lbs. of $\frac{3}{32}$ -inch rods; 4 $\frac{1}{2}$ lbs. of $\frac{1}{8}$ -inch rods; and 4 $\frac{1}{2}$ lbs. of $\frac{5}{32}$ -inch rods. Rods for cast iron welding; 4 $\frac{1}{2}$ lbs. of $\frac{1}{8}$ -inch diameter rods. Rods for hard surfacing; 4 $\frac{1}{2}$ lbs. of $\frac{1}{8}$ -inch rods. 99 A 02024—Complete assortment. Shipping weight 22 pounds. **\$6.25**

Welding Electrodes

F CRAFTSMAN. Individual types for specific purposes. Specially flux-coated for use on all A.C. or D.C. (D.C. reverse polarity) welders. Easy striking; assure minimum spatter loss and easy slag removal. Shipping weight of 5-lb. size is 5 lbs. 12 oz.; 25-lb. size, 29 lbs. Order by catalog number and state size needed.

9 A 2003—General purpose type recommended for use on mild steel. Please state size wanted.

Size	$\frac{3}{32}$ -inch	$\frac{1}{8}$ -inch	$\frac{5}{32}$ -inch	$\frac{3}{16}$ -inch
5 lbs.	\$1.55	\$1.25	\$1.15	\$1.15
25 lbs.	7.40	5.90	5.40	5.40

9 A 2055—For use on cast iron. State size.

Size	$\frac{3}{32}$ -inch	$\frac{1}{8}$ -inch	$\frac{5}{32}$ -inch	$\frac{3}{16}$ -inch
5 lbs.	\$1.65	\$1.35	\$1.19	\$1.19
25 lbs.	7.90	6.40	5.60	5.60

9 A 2004—For hard surfacing. State size.

Size	$\frac{1}{8}$ -inch	$\frac{5}{32}$ -inch	$\frac{3}{16}$ -inch
5 lbs.	\$2.98	\$2.79	\$2.59
25 lbs.	14.45	13.45	12.45



\$215.00 CASH
99 AM 2015
\$22 DOWN... ON EASY TERMS

CRAFTSMAN Arc Welders

Industrial type . . . built to highest standards

Buy a CRAFTSMAN and be SURE you're getting one of the finest electric arc welders made! They give you a complete range of welding currents for every kind of work . . . welding, cutting, brazing, soldering or heating.

Greater efficiency and reduced current consumption because the welder transformers have high power factor. Almost impossible to burn them out when used at correct voltage . . . because the windings are insulated with spun glass . . . the finest insulation used in arc welders today. Coils are dipped in varnish and baked.

Greater safety . . . approved by Underwriters' Laboratories, Inc. and meet all their standards for safety, freedom from fire hazard and maximum temperature rise. Natural draft cooling . . . no fans used. Cooler operation even under continuous service. Fire-resistant all-metal cabinets. Control panel fully protected against dirt and dust. Approved code-type switch. Stub wire leads for power line connection. Steady arc at all heats. Built-in reactance automatically increases voltage at low heats.

Accessories include: 5 lbs. of assorted welding electrodes, wire brush, carbon electrode, electrode holder, two 15-ft. cables, welding helmet and instructions.

Before ordering, please check voltage, cycle, phase and capacity of your power line. For use on single phase 220-230 volt 60 cycle A.C. only.

SPECIFICATIONS:	99AM2015	99AM2012
• Maximum amperes actual welding current delivered.	300 amperes	200 amperes
• Welding heats available (actual welding current)	Thirty; 20 to 300 amps	Eighteen; 20 to 200 amps
• Maximum rod size	$\frac{1}{8}$ inch	$\frac{3}{16}$ inch
• Type of service	Continuous	Continuous
• Current supply required.	Single phase 220-230 volt A.C.	Single phase 220-230 volt A.C.
• Maximum open circuit secondary volts	94 volts	94 volts
• Maximum line draw	65 amperes	48.5 amperes
• Maximum kilowatts	8.2 kilowatts	6.2 kilowatts
• Maximum kilo-volt-amperes	14.3	10.7
• Cabinet dimensions, Height	37 inches	33 inches
Width	23 inches	20 inches
Depth	21 inches	21 inches

99 AM 2015—Shipping weight 330 pounds. **\$215.00**
99 AM 2012—Shipping weight 260 pounds. **\$160.00**

Learning to Weld is Easy



Save time and money; do your own welding. It's so easy to learn how. Each CRAFTSMAN Arc Welder Outfit includes a booklet of easy-to-follow instructions plus a generous supply of practice welding rods. Read the directions . . . get a little practice . . . soon you'll be able to weld well enough to do 95% of your repair jobs.

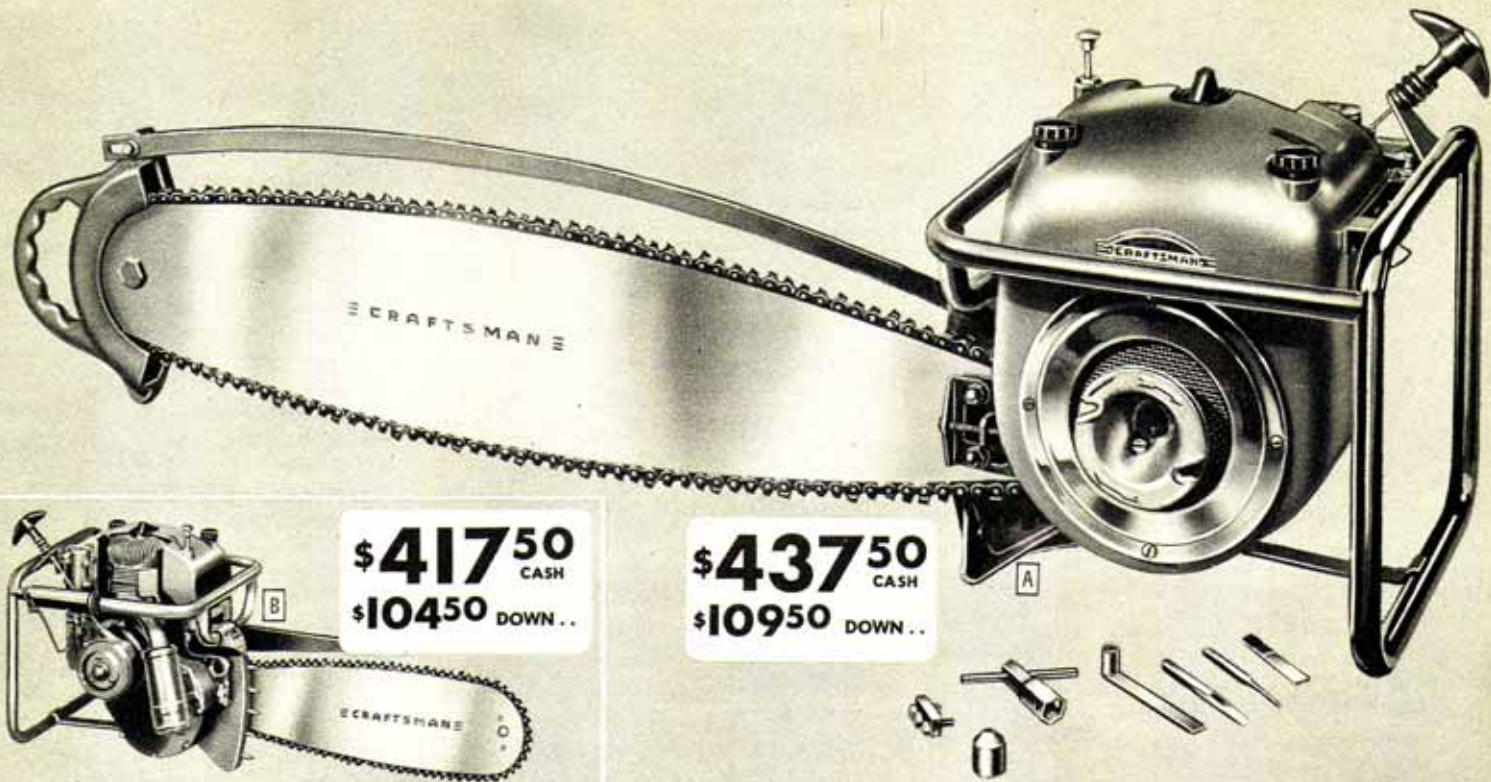

CRAFTSMAN Power Timber Saw

- Greatly improved . . . now better than ever
- Cuts 5 times faster than two-man hand saw
- Two popular sizes . . . 30 and 20 inch blade

Once you see this CRAFTSMAN power timber saw in operation or use it yourself, you'll insist upon one for all your timber cutting jobs. It's the fastest, easiest, smoothest operating timber saw we've seen. New improvements . . . improved diaphragm-type carburetor for operation at angles up to 90 degrees or better without stalling; improved magneto for quicker, easier starting; improved clutch for greater strength and more positive action; additional weight and strength to parts subject to strain . . . give this saw the features you need in a power timber saw.

Over 5 times faster. In actual cutting tests *one man notched and felled a 20-in. tree in two minutes* with 20-in. timber saw (It took two men 10 minutes with cross-cut saw); *one man bucked 6.390 cords of 16-inch diameter logs in 4 hours* with 20-in. timber saw (He bucked only 0.985 cords in same time with an ordinary crosscut saw); *two men bucked 10.27 cords of 15-in. diameter logs in 4 hours* with 30-in. timber saw (They bucked only 1.97 cords in same time with ordinary crosscut saw).

Lightweight construction. Use of light, tough alloys and a specially designed aircraft-type engine make this lightweight possible. Easy to use to get into close places . . . a very important advantage.

Tremendous demand for timber of all kinds . . . Farmers . . . can earn extra money by cutting timber on your own and neighboring farms. **Timber companies . . .** you can speed production and cut labor costs by equipping your crews with these saws. You can save thousands of dollars on large jobs. Also ideal for parks, highway departments, construction firms, etc.

SPECIFICATIONS:

- Engine 4.2 H.P. at 4500 R.P.M., single cylinder, two-cycle, air cooled
- Carburetor Diaphragm-type
- Magneto High tension, water-proof
- Starter Spring with automatic recoil
- Throttle Automatic return
- Fuel tank capacity 1 3/4 quarts
- Transmission Alloy steel gears
- Bearings Grease-sealed precision ball
- Blade sizes 20-inch and 30-inch
- Saw chain 5/16-inch kerf; 3/4-inch pitch
- Speed of chain 1200 F.P.M. at 4500 R.P.M.

Comes complete with the following equipment: saw guard, guide bar, saw chain, 18 rivets, 9 extra connecting links, 5 extra right hand cutter teeth, 5 extra left hand cutter teeth, 3 extra right hand rakers, 3 extra left hand rakers, 3 extra center rakers, suitable wrench, anvil, gauge, punch, chisel, wheel puller and illustrated instruction book telling you how to operate saw.

A 99 AM 2460—30-inch blade saw. For 2-man operation. Has helper's end. Length 54 1/2 in. Actual weight 67 lbs. 6 oz. Shpg. wt. 87 lbs. **\$437.50**

B 99 AM 2458—20-inch blade saw. Use as 1-man saw or 2-man saw with helper's end (below). Length 36 1/2 in. Actual weight 57 lbs. Shpg. wt. 82 lbs. **\$417.50**

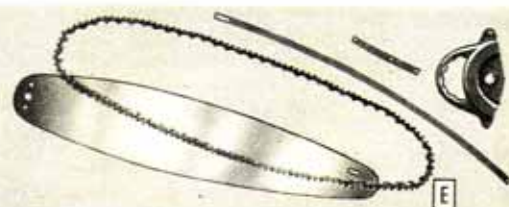
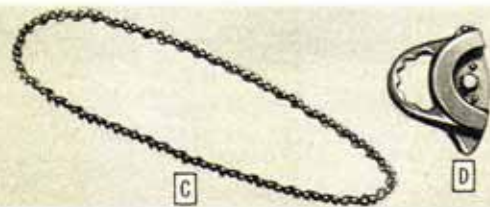

High quality Accessories for CRAFTSMAN Power Timber Saw

C **Extra Saw Chains.** For the CRAFTSMAN Power Timber Saws described above. Have 5/16-inch kerf and 3/4-inch pitch. Easily sharpened with file or sharpener. Keep an extra one on hand in case of emergency. Easily and quickly installed.
 9 A 2304—For 30-inch blade timber saw. Shipping weight 3 pounds. **\$25.50**
 9 A 2302—For 20-inch blade timber saw. Shipping weight 2 lbs. 8 oz. **\$18.95**

D **Helper's End.** Makes it possible to use the 20-inch timber saw as a two-man saw. Two-man operation is recommended for large jobs. Easily and quickly attached or removed. 9 A 2303—Shipping weight 5 lbs. **\$5.85**
E **Conversion Kit.** For converting 20-inch saw into 30-inch saw. Kit includes: saw chain, guide bar, helper's end and guard. 99 A 02305—Shpg. wt. 31 lbs. **\$67.00**

F **Saw Chain Grinder.** Makes it possible to do a much easier, faster and more accurate job of sharpening saw chains. Far superior to hand filing. Frame holds saw chain in correct position for sharpening. Adjustments make possible extremely accurate grinding of the cutting teeth. Pivots horizontally or vertically . . . accurate graduations show angle of tilt. Grinding unit has narrow-dished 6-inch diameter vitrified grinding wheel. Spur gears in grinder have 11 to 1 ratio. 9 A 2359F—Shipping weight 34 pounds. **\$57.00**

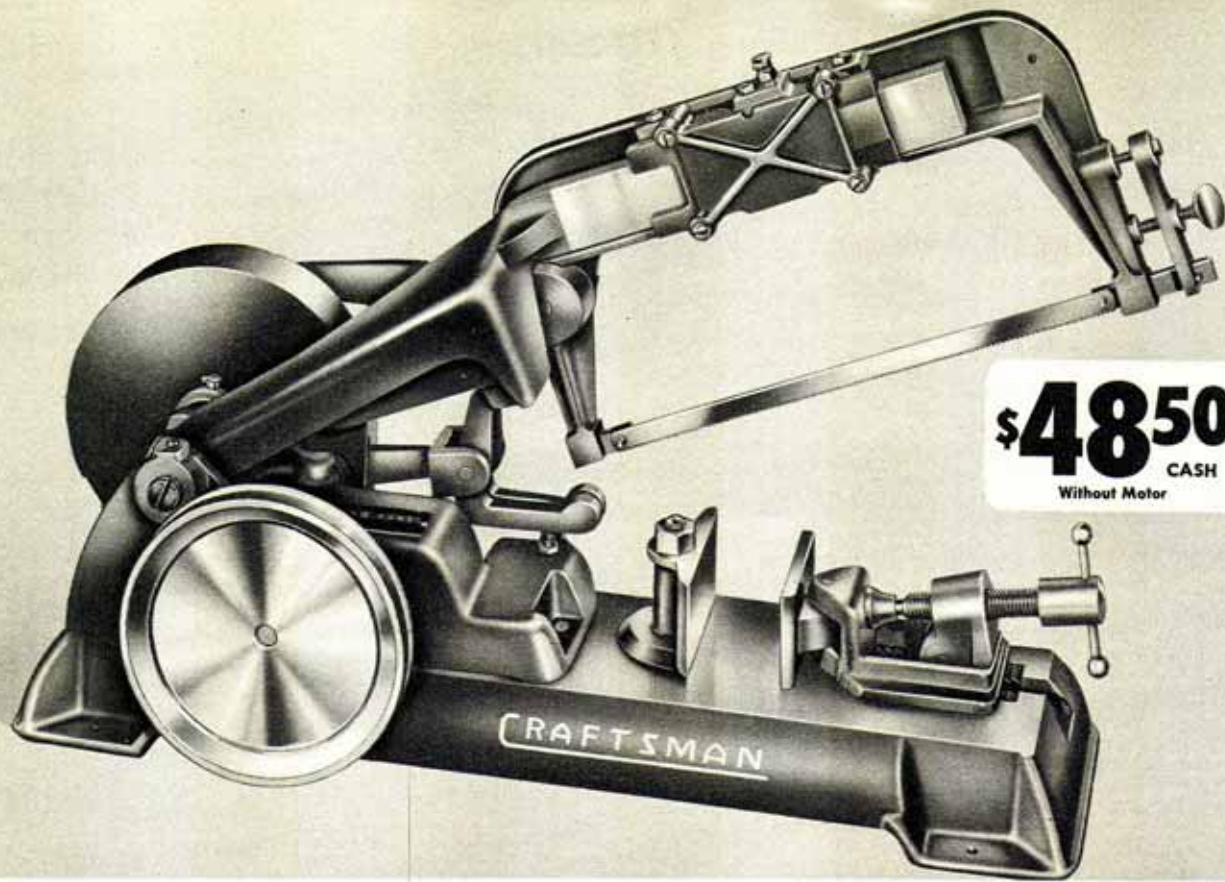

\$4850 **\$500**
CASH DOWN . . .
Without Motor ON TERMS

CRAFTSMAN "80" Power Hack Saw

Heavy duty model . . . semi-automatic . . . cuts accurately unattended

Save time . . . save labor . . . reduce operating costs . . . speed up production . . . when you use this CRAFTSMAN "80" Power Hack Saw. Ideal for plumbers, electricians, garages and other metal workers.

Extra large capacity. This power hack saw makes cuts on material up to 4x4 inches at 90° . . . makes angles cuts 90° to 45°. It will cut iron, steel, brass, aluminum, etc; quickly and accurately. It has a 5-inch stroke; 60 strokes per minute, at 400 R.P.M.

Fully automatic. The CRAFTSMAN "80" makes cuts alone while you work at other jobs. Just place material in quick-locking vise, adjust for correct angle and turn on the power. That's all there is to it. Draw

cut action lifts blade from the work on the return stroke. Gives a clean, accurate cut.

Rugged construction. Shafts run on extra large bronze oilite bearings. Slide and arm made of special wear-resistant cast semi-steel. Arm pivot is cone type; adjustable construction. Oiled through spring oilers.

SPECIFICATIONS:

- Capacity, maximum 4x4 inches
- Angle cuts 90 to 45 degrees
- Bearings Bronze, oilite
- Length of blade 12 inches
- Width of blade 1/2 inch
- Machine pulley (included) 6 1/2-inch

- Motor pulley (not included), 1 1/2-inch
- Motor recommended, min. 1/2 H.P. 1750 R.P.M.
- Base size 6x24 inches
- Mounting dimensions 5 1/2 x 19 1/4 inches
- Over-all dimensions: height 10 inches; width 9 inches; length (extended) 29 (not extended) 26 in.
- 99 AM 2294—Without motor. Shpg. wts. 60 lbs. **\$48.50**
- 99 AM 2285—With 1/2 H.P. 1750 R.P.M. split phase ball bearing 110-120 volt A.C. motor, 1 1/2 in. motor pulley 1/2x42-in. V-belt. Shpg. wt. 90 lbs. **\$67.00**
- 99 A 6582—CRAFTSMAN—12-inch power hack saw blades. Special tool steel, 14 or 18 teeth per inch. **\$2 for 98c**
- State choice wanted Shpg. wt. 3 oz.

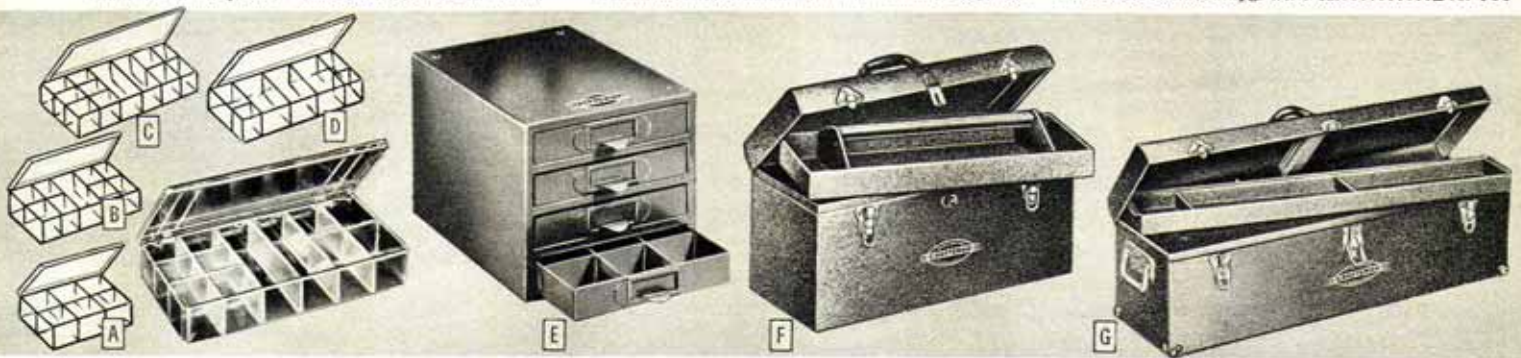

Transparent Plastic Utility Boxes

Don't mislay those small machine, radio or electrical parts! Store them safely in one of these transparent plastic boxes. The ideal container for holding hobby shop items, fishing tackle—flies, lures, hooks, etc.; tacks, screws, nails, washers, etc. Exceptionally lightweight. Thick transparent plastic walls keep items separated, yet easy to find without opening the box. Dirt and dust-free! Have snug covers with smooth working hinges. Available in various sizes with various size compartments. See small views above for the types available.

Catalog No.	Compartment	Length	Width	Depth	Shpg. wt.	Each
A . . . 9A6525	...Six	4 1/2 in.	2 3/4 in.	1 in.	8 oz.	69c
B . . . 9A6523	...Nine	7 in.	3 1/2 in.	1 1/4 in.	9 oz.	89c
C . . . 9A6530	...Twelve . . .	8 3/4 in.	4 1/4 in.	1 1/4 in.	11 oz.	\$1.19
D . . . 9A6526	...Seven	8 3/4 in.	4 3/4 in.	1 3/4 in.	11 oz.	1.19
9A6528	...Eighteen . .	11 in.	6 3/4 in.	1 3/4 in.	1 lb. 2 oz.	2.35

Tool Cabinet

E Handy four-drawer tool cabinet. Ideal for storing small tools and parts. Drawer fronts have useful index card holders and pulls. Made of 24-gauge sheet steel, electrically welded. Dimensions: length 10 in.; width 7 1/2 in.; height 8 1/2 in. Each of four drawers, 7 1/2 x 10 x 1 1/4 in., have 12 partitions that are adjustable and removable. Smooth machinery gray finish. Shpg. wt. 8 lbs.

9 A 6531 **\$5.25**

Mechanics' Tool Box

F CRAFTSMAN quality. Size of tool box: 20x8 1/2x9 3/4 inches. Holds 75 to 100 sockets and socket wrench parts. Has sufficient room for all the tools a mechanic will need for the job. Made of 22-gauge steel, electrically welded for added strength. All edges are rounded for protection. Equipped with full length, easy-action piano-type hinge. The large, partitioned, lift out "tote" tray is excellent for keeping small tools in order. Has two lever-type latches and a hasp with padlock eye. Cover has heavy aluminum handle for easy carrying. Machinery gray rust-resisting finish. Shpg. wt. 11 lbs.

99 A 06512 **\$5.25**

Carpenters' Tool Box

G CRAFTSMAN. Size 30x8 1/2x9 inches. Large enough to hold a full set of carpenter's tools. Splendid for mechanics and plumbers who use long tools. Made of 22-gauge steel with 20-gauge steel end plates; electrically welded. Edges rounded for safety. Divided tray for storing small tools. Equipped with wood saw clips in both top and bottom to hold four hand saws. Metal handles on both ends and on top. Full-length piano-type hinge. High quality lock and keys. Extra strong loop-type side hasps. Rust-resisting machinery gray finish. Shpg. wt. 20 lbs.

99 A 06517 **\$8.95**

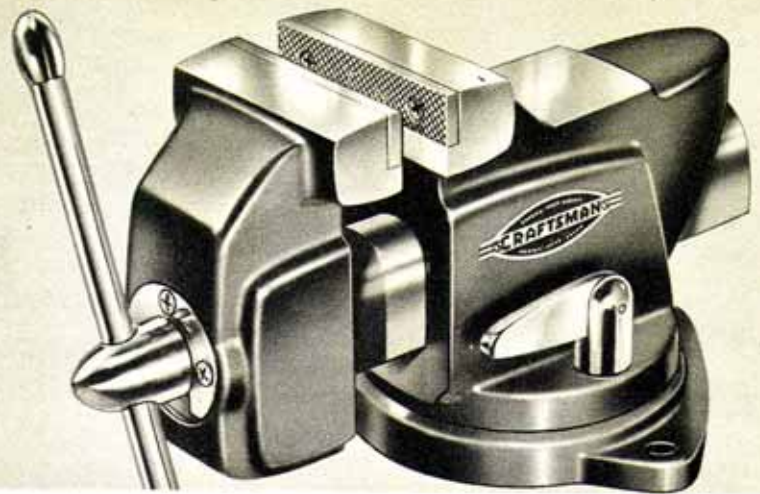
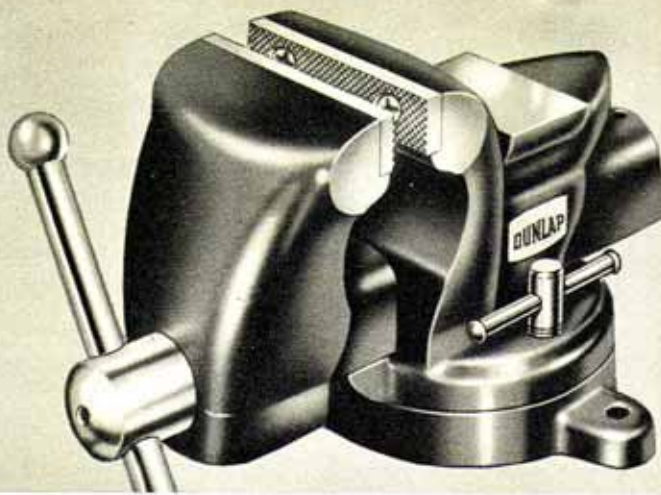

Bench Vises . . . extra Heavy Construction

DUNLAP Bench Vise . . . good quality priced low

Don't be misled by Sears low price! You'd expect to pay much more for a sturdy, well-made vise like this. There's rugged, heavy-duty quality built into every detail. Has everything a good bench vise should have . . . precision workmanship, extra weight, and added strength. This means better performance and longer life in your shop or garage.

\$750

Husky, semi-steel body . . . much stronger than cast iron . . . strongly reinforced at all points of strain. Oversize cold rolled steel U-shaped slide beam fits snugly, yet slides easily; jaws won't wobble . . . filings and foreign matter won't injure threads. Acme-threaded steel screw has more threads per inch for tighter grip.

Replaceable, oil-tempered and hardened steel jaw faces have deep-cut knurls to assure a firm, strong grip on materials . . . hold objects rigidly regardless of shape. The 3½-inch jaws open to 4¼ inches.

Swivel base turns left or right a full 180 degrees . . . has positive-locking 3-point contact . . . locks in any position. Rust-resisting red crackle finish.

99 A 05244—Shipping weight 17 pounds. *Mailable* **\$7.50**

99 A 05243—Same bench vise as above but with additional set of pipe jaws. Shpg. wt. 23 lbs. *Mailable* **\$7.75**

CRAFTSMAN Bench Vise . . . professional quality

By far the finest vise of this type we've ever sold! You'll have an entirely new idea of vise quality when you see this superb new design and try its exceptionally smooth, easy action. Really a beauty to look at . . . built for extra heavy duty . . . packed with rugged brute strength in every part. Body is strongly reinforced at all points of strain. All parts precision-machined; complete interchangeability is possible.

\$1395

3½-in. jaws

Hardened and tempered, deep-knurled jaw faces are replaceable to permit longer vise life . . . keep a firm, strong grip on the work. Cold rolled steel "U" beam slides easily . . . fits snugly . . . prevents jaw wobble. Beam completely covers the screw to protect it against dirt and filings . . . helps maintain the exceptionally smooth, easy action. Acme-threaded steel screw has 6 threads per inch.

New-type, oval-shaped stops at ends of the handle help prevent pinched fingers. Convenient, new-type handle on swivel base eliminates the nuisance of a sliding bar. Swivel base turns full 360 degrees . . . locks at any desired angle. Gray enamel finish; jaws, beam, anvil and handles are highly polished.

99 A 05176—3½-inch jaws open 5 inches. Shpg. wt. 29 lbs. *Mailable* **\$13.95**

99 A 05169—4 -inch jaws open 5 inches. Shpg. wt. 35 lbs. *Mailable* **16.50**

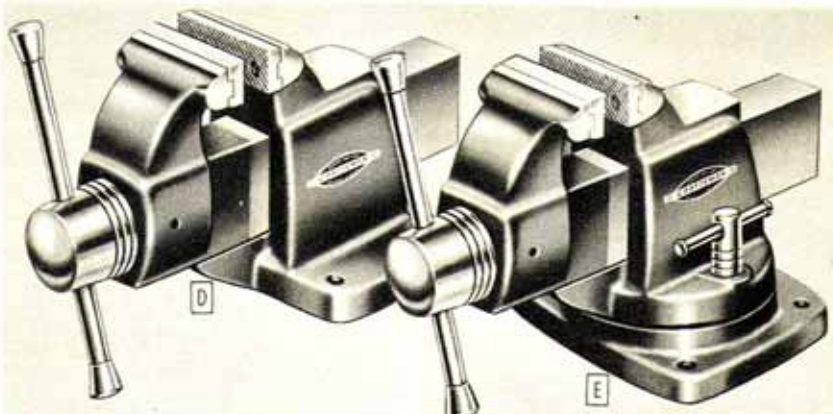
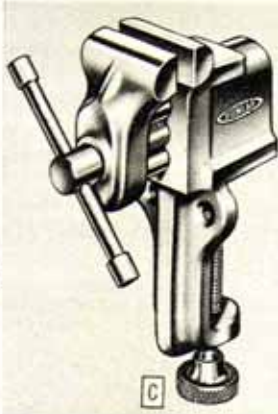
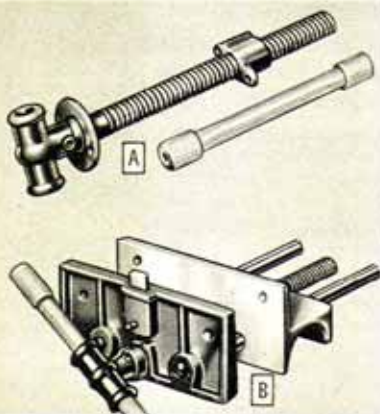

Bench Screw with Handle

A For replacement in old, worn-out bench vises, or making new woodworkers' vises, fruit presses, etc. Strong steel screw; Acme-cut threads. Standard 15½-in. length. 14-in. hardwood handle. 9 A 6662—Please state size wanted. 1-inch diameter screw. Shipping weight 5 pounds 8 ounces **\$2.25**
1½-inch diameter screw. Shipping weight 6 pounds 10 ounces **2.25**

Woodworkers' Vise

B CRAFTSMAN. Heavy semi-steel front and back jaws; smooth ground faces; holes for fastening wood faces to jaws if desired. Adjustable bench stop on front jaw. Acme-threaded steel screw assures smooth accurate movement of the jaws. 10-inch jaws; open to 10 in. 99 A 05200—Shpg. wt. 20 lbs. **\$12.50**
Quick-acting Woodworkers' Vise. (Not shown.) Similar to above, but half turn of handle disengages screw; permits jaw to slide back and forth. Turn in opposite direction again engages screw. 99 A 05201—Shpg. wt. 20 lbs. **\$15.50**

DUNLAP Clamp Vise

C A splendid little vise for home, shop or farm. Ideal for the repair man who has to carry tools around on the job . . . for the model maker . . . or for anyone who works in limited space. Easily clamps to bench or table up to 2 inches thick. Twin-guide rod construction and clean-cut screw assure smooth action. Jaws and body of cast steel. Machined jaws meet squarely and give a firm grip. Jaws 1½ inches wide; open 2 inches. Over-all height (with clamp closed) about 6 inches. Over-all width (with jaws closed) about 4 inches. 9A5245—Shipping wt. 2 lbs. 8 oz. **\$1.75**
9 A 5247—(Not shown.) As above, but larger. Jaws 2½ in. wide; open 2¾ in. Shpg. wt. 4 lbs. 8 oz. **\$2.95**

CRAFTSMAN Industrial Machinists' Vises

\$1750
CASH
99 A 05190

Tremendously improved! So well made, we can positively guarantee them for 20 years against defects in materials and workmanship! Professional quality . . . especially constructed for daily service and heaviest machine shop work. You won't find a better machinists' vise in this price range anywhere else.

\$2375
CASH
99 A 05195

\$2.50 DOWN

Beautiful streamlined design. Semi-steel construction for greatest strength, reinforced at all points of strain. Alloy steel facings on jaws are replaceable to prolong life of vise; deep-knurled to hold work of any shape more firmly. All parts precision-machined for a snug fit, and to provide complete interchangeability. Heavy milled beam fits snugly; slides smoothly in double-broached rectangular hole through body. Head and collar bearings are machined to lessen screw wear. Three separate precision adjustments to take up end play and wear. Screw and handle are cold rolled steel. No pinched fingers, with new tapered ball ends and internal spring that prevents handle from dropping.

Machined base insures smooth bearing surface; jaws are always parallel to work bench . . . 4 anchor holes instead of only 3 eliminate all danger of vise working loose from the bench. Swivel-base model turns full 360 degrees; has cog swivel base lock and base track that locks positively in any position desired; gives just as much rigidity as solid base vise. All vises listed below have polished anvil surface for flat work. Two oil holes.

D CRAFTSMAN Solid Base Machinists' Vises

Cat. no.	Jaws	Open	Shpg. wt.	Each
99 A 05190	3½-in.	5½ in.	38 lbs.	\$17.50
99 A 05191	4 -in.	7 in.	48 lbs.	19.75

Shpg. wts. above and right, are also actual wts. Sizes over 70 lbs., freight or express.

E CRAFTSMAN Swivel Base Machinists' Vises

Cat. no.	Jaws	Open	Shpg. wt.	Each
99 A 05195	3½-in.	5½ in.	46 lbs.	\$23.75
99 A 05196	4 -in.	7 -in.	59 lbs.	26.75
99 AM 5197	4½-in.	8 -in.	77 lbs.	31.75
99 AM 5198	5 -in.	8¾ in.	107 lbs.	48.00

Why not pay for your equipment while using it? See inside front cover for details on Sears Easy Terms



1 Grease-sealed precision ball bearings.



2 Heavy 8-ft. cord and unbreakable plug.



3 Double shaft makes motor more useful.



A 1/2 H.P.
\$2350
 CASH
\$2.50 DOWN



B 1/2 H.P.
\$3795
 CASH
\$4.00 DOWN

Sears high quality Electric Motors

CRAFTSMAN Capacitor Motors . . . massive, powerful

A Efficient motors for use in shops, factories, industrial plants, etc., for driving power tools or other equipment. Notice that all five features shown at left are included at no extra charge.

Built-in condenser reduces starting current. Permits motor to start loads about 50% heavier than split phase motors of the same power rating . . . as a result these motors cost less to run . . . use about 3/4 the starting current and cause less flicker of lights when motor is started. Condenser is not attached to outside of motor, but is enclosed in massive cast iron base.

Built-in Klixon overload protector prevents burn-out. Shuts off current automatically when motor is overloaded. Manually re-set when motor cools.

Grease-sealed precision ball bearings assure long easy-running service. Seal protects bearings against dirt and moisture. Motor may be used in any position. On-off switch in base. Easily reversed.

Specially designed fan and baffles keep all parts of motor cool. 3/4-inch shaft, except 99A01981 which has 3/8-inch keyway, extends on both ends. For 110-120-volt 60-cycle A.C. 8-ft. cord and plug. Mounting dimensions 3 3/4 x 5 inches.

99 A 01977—1/2-H.P. 1750 R.P.M. Shipping weight 33 lbs.	\$23.50
99 A 01978—1/2-H.P. 1750 R.P.M. Shipping weight 35 lbs.	27.95
99 A 01980—1/2-H.P. 3450 R.P.M. Shipping weight 37 lbs.	29.95
99 A 01981—1/2-H.P. 3450 R.P.M. Shipping weight 44 lbs.	38.95

CRAFTSMAN mill-type Capacitor Motors

B Extra heavy duty motors for production work in factories, mills, etc. Especially designed to incorporate features and improvements demanded by these users. Will do an exceptionally fine job on the farm, too.

Really power packed. Have heavier windings . . . sturdier, larger frames . . . extra power . . . easily handle greater overload capacity than standard motors of this type. Runs amazingly cool under heavy loads, to give long motor life.

Built-in condenser reduces starting current. Permits starting loads about 50% heavier . . . cost less to run . . . cause less flicker of lights. Start easily and come to speed rapidly.

Built-in Klixon overload protector prevents burn-out. Shuts off current when motor is overloaded. Easily re-set when cool.

Heavy duty, grease-sealed precision ball bearings. Motors may be used in any position. Massive cast iron base. 3/4-in. shaft extends 2 3/4-in. on one end; has keyway. For 115-230-volt 60-cycle A.C. 1750 R.P.M. Mounting dimensions 5x5 3/4 inches.

99 A 01985—1/2-H.P. Shipping weight 53 lbs.	\$37.95
99 A 01986—3/4-H.P. Shipping weight 58 lbs.	44.95
99 A 01987—1-H.P. Shipping weight 63 lbs.	49.95



4 Convenient on-off switch built into base.



5 Overload protector prevents burn-out.

DUNLAP 1/4-H.P. Split Phase Motor

C Rugged, well-made motor designed for general use on easy-starting loads such as washing machines, light power tools, etc. Excellent performance and trouble-free operation. All parts guaranteed against defects in material or workmanship.

Dependable construction. Husky bronze bearings for smooth operation and long life. Motor should be used in horizontal position only. Easily reversed. Cast iron base gives motor solid mounting. 3/4-inch shaft extends 1 1/2 inches on one end. For use on 110-120-volt, 60-cycle A.C. 1750 R.P.M. With 8-foot rubber covered cord and unbreakable plug. Mounting dimensions 3 3/4 x 5 inches.

99 A 01974—Shipping weight 24 pounds	\$10.50
--------------------------------------	----------------

DUNLAP 1/3-H.P. Split Phase Motor

D Gives you that "built-in" extra power you want, plus these great features . . . double shaft, ball bearings, on-off switch, cord and plug . . . all at a price you can afford to pay. Just the motor you need for operating your light power tools, light compressor, ventilating fan, washing machine, etc. We believe this is America's greatest value in 1/3-H.P. split phase motors . . . actual laboratory test and merchandise comparisons show that you get MORE for your money when you buy this DUNLAP electric motor.

Heavy duty! Super powered! Exceeds National Electrical Manufacturers' Association specifications. Handles more than TWO times rated H.P. before stalling. Efficient modern design eliminates excess weight. Deep end bells and baffled openings ventilate motor . . . assure cool operation. All parts are guaranteed against defects in materials or workmanship for one year.

Grease-sealed precision ball bearings allow you to operate motor in any position. 3/4-inch drive shaft extends 1 3/4-in. on both ends . . . permits convenient operation of two tools. Handy on-off switch in base. Massive cast iron base. Easily reversed. Extremely quiet running and highly efficient in operation. For use on 110-120-volt, 60-cycle A.C. 1750 R.P.M. Complete with 8-foot rubber-covered cord and unbreakable plug. Mounting dimensions 3 3/4 x 5 inches.

99 A 01975—Shipping weight 29 pounds	\$17.50
--------------------------------------	----------------

Equip your shop now with CRAFTSMAN famous tools! Use Sears Easy Payment Plan . . . See inside front cover for complete details.

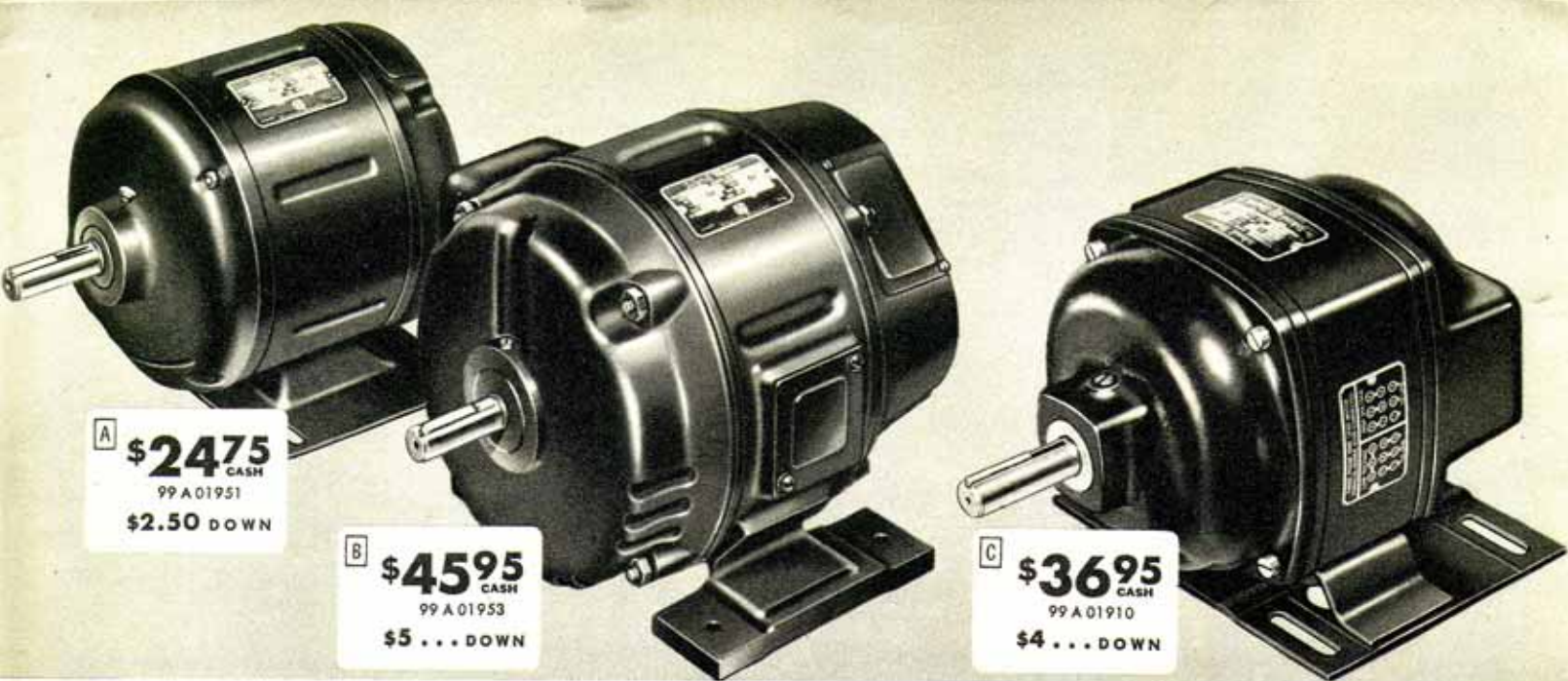

A
\$2475
 CASH
 99 A 01951
\$2.50 DOWN

B
\$4595
 CASH
 99 A 01953
\$5 . . . DOWN

C
\$3695
 CASH
 99 A 01910
\$4 . . . DOWN

Dependable power for your Power Tools

Powerful Repulsion-Induction and 3-Phase Motors

These are the motors for the hardest starting loads. For use on low voltage lines or in severe climatic conditions. No finer motors of this type are built! Every part is super-strong . . . made to the most exacting specifications. Used in shops and factories for steady day-in day-out production work.

Tremendous overload capacity for the tough jobs. Develop THREE to FIVE times the rated H.P. while starting.

Finest quality bearings. Diamond-bored phosphor bronze bearings in repulsion-induction sizes under 1 H.P. . . must be used in horizontal position. Other sizes

have grease-sealed precision ball bearings . . . may be operated in any position.

Husky, improved round frame for better ventilation. Large air vents and powerful fan keep extra heavy windings cool. Designed not to exceed 40 degrees Centigrade temperature rise under normal operation. Air vents are drip-proof protected. Massive base gives motor solid mounting.

Meet all A.I.E.E., N.E.M.A. and central station requirements. Easily reversed. Shafts have keyways. Before ordering, check your local power company on voltage, cycle, phase and capacity of your line.

Single Phase Repulsion Induction 110-120-volt, 60-cycle A.C.						
Catalog Number	H.P.	R.P.M.	Shaft	Base Mounting	Shpg. wt.	Price
(A) 99 A 01951	3/4	1750	3/8 in.	3 1/2 x 5 1/2 in.	32 lbs.	\$24.75
99 A 01952	1	1750	3/8 in.	5 x 5 1/2 in.	36 lbs.	35.75
(B) 99 A 01953	3/4	1750	3/8 in.	5 x 5 1/2 in.	61 lbs.	45.95
99 AM 1938	1	1750	3/8 in.	5 1/2 x 8 in.	84 lbs.	70.00
99 AM 1939	1	3450	3/8 in.	5 x 5 1/2 in.	74 lbs.	54.50
99 AM 1940	1 1/2	1750	3/4 in.	6 1/2 x 8 in.	96 lbs.	90.00
99 AM 1941	2	1750	1 in.	6 1/2 x 9 in.	130 lbs.	115.00
99 AM 1942	2	3450	3/4 in.	6 1/2 x 8 in.	96 lbs.	100.00
99 AM 1943	3	1750	1 in.	7 1/2 x 9 in.	141 lbs.	145.00
99 AM 1944	5	1750	1 1/2 in.	8 1/2 x 10 in.	192 lbs.	215.00

*Three-Phase Repulsion-Induction 220-440-volt, 60-cycle A.C.						
Catalog Number	H.P.	R.P.M.	Shaft	Base Mounting	Shpg. wt.	Price
(C) 99 A 01910	3/4	1750	3/8 in.	5 x 5 1/2 in.	39 lbs.	\$36.95
99 A 01911	1	1750	3/8 in.	5 x 5 1/2 in.	57 lbs.	45.95
99 AM 1912	1	1750	3/8 in.	5 1/2 x 8 in.	81 lbs.	58.00
99 AM 1913	1 1/2	1750	3/4 in.	6 1/2 x 8 in.	86 lbs.	68.00
99 AM 1914	2	1750	1 in.	6 1/2 x 9 in.	105 lbs.	78.00
99 AM 1915	3	1750	1 in.	7 1/2 x 9 in.	115 lbs.	87.00
95 AM 1916	5	1750	1 1/2 in.	8 1/2 x 10 in.	128 lbs.	103.00

*IMPORTANT! Most homes and farms have single phase current. 3-phase is usually used in factories. Check with your power company before ordering.

Important! Be sure to buy the right motor for your needs

(1) Check your power company for current supply you have, and make sure line is heavy enough to carry motor wanted . . . (2) Use a motor that is big enough for the job; a motor slightly too large will last years longer than one slightly too small . . . (3) Remember, bronze bearing motors must be used with shaft horizontal . . . (4) Use the right type of motor for the job.

Split phase motors . . . For easy-starting loads, such as washing machines, ventilating fans, light power tools, etc.

Capacitor motors . . . For medium starting loads, such as heavier power tools and paint sprayers, refrigerators, stokers, etc.

Mill-type capacitor motors . . . For medium to hard-starting loads. Ideal for production equipment, compressors, heavy power tools, etc.

Repulsion-induction and 3-phase motors . . . For hard-starting jobs, such as deep-well pumps, large compressors, heavy industrial tools, etc. (3-phase motors can be used only on 3-phase current.)

Tool Light

D Improper lighting in the shop costs money! You'll save money and have proper light if you use this handy work light. 18-inch flexible cable gooseneck permits movement to any desired position . . . shade swivels 360°. Interlocking socket cannot be pulled apart. C clamp for fastening to work bench or tool. All steel; gray enameled. Takes 60-watt or smaller bulb. 110-120-volt AC. 6-ft. plastic cord and plug. Shpg. wt. 2 lbs.
 9 A 2536 \$3.49

CRAFTSMAN Motor Rails

E Floating Motor Rail. Use one motor for several tools! Just fasten clips near each tool, and shift motor with rail where needed. With one pair of clips.
 9 A 2275—Shipping weight 1 lb. 13 oz. Set \$1.15
 9 A 2277—Pair clips only. Shpg. wt. 7 oz. 40c

F Adjustable Motor Rails. Use where motor is not to be removed. To adjust belts, just loosen bolts, slide motor for belt tension wanted; then tighten bolts.
 9 A 2279—Shipping weight 3 pounds. Per pair \$1.50

G Deluxe Floating Motor Rail. All the advantages of ordinary rails . . . plus support for rear end of motor, rubber cushioning, and right angle clips. Clips allow motor to be mounted either behind or under tool. Rear rail pivot support carries rear end of motor.
 9 A 2326—Shipping weight 2 pounds. Set \$2.35
 9 A 2328—Pair clips only. Shipping wt. 10 oz. 77c

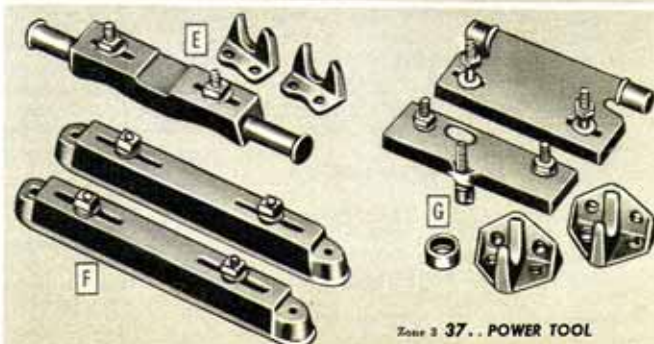
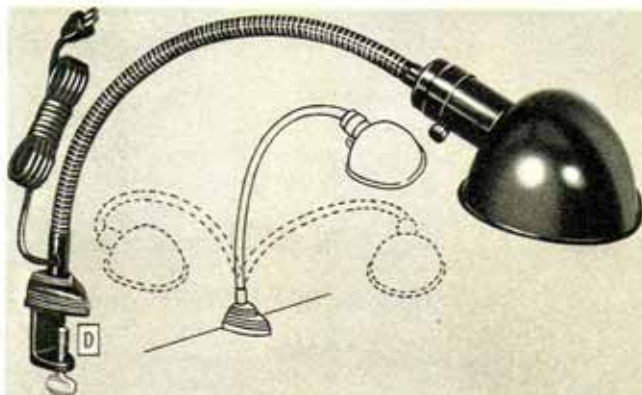

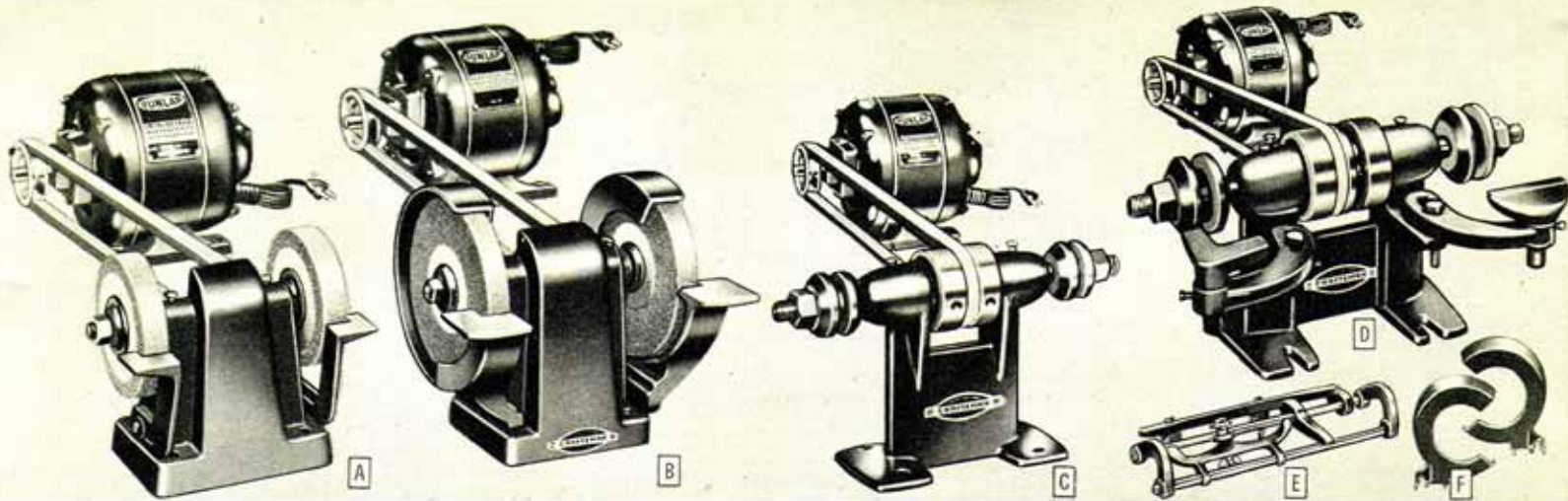

CRAFTSMAN Grinders and Polishing Heads

4-inch Grinder

A Cast iron frame. Gray enameled. Enclosed drive pulley. 8x3/8-in. steel spindle, turned down to 3/8-in. at ends; 20 thread. Fits standard accessories. 2-in. V-drive pulley for 3/8 or 1/2-in. V-belt (not included). Spring cap oil cups. Tool rest. Two 4x3/8-in. grinding wheels; one fine and one medium grit. Shpg. wt. 7 lbs. 4 oz. 9 A 6628.....\$5.75

99 AT 6653—Grinder head with 3/4-H.P. 1750 R.P.M. split phase 110-120-volt A.C. motor, 5-in. motor pulley and 3/8x34-inch V-belt. Shipping weight 32 pounds.....\$17.70

CRAFTSMAN 6-inch Grinder

B Heavy duty. Ample clearance between wheel centers; plenty of high clearance for larger jobs. 9 3/8-in. spindle; 3/8-in. diameter, turned down to 3/8-in. at ends; 20 thread. Fits standard accessories. Long oilite bronze bearings; oil well around each. Adjustable wheel guards and tool rests. Spring cap oil cups. Shielded 2-step V-drive pulley for 3/8 or 1/2-in. V-belt (not included). Gray enameled. Two 6x3/8-in. vitrified grinding wheels; one fine, one medium grit. 99 A 06614—Shpg. wt. 19 lbs...\$11.95

99 AT 6655—Grinding head and wheels with 3/4-H.P. 1750 R.P.M. split phase 110-120-volt A.C. motor, 5-in. motor pulley and 3/8x34-inch V-belt. Shipping weight 43 pounds.....\$23.90

ALL purpose Grinder

C 12 3/8-in. spindle, 3/8 in. at ends. Long oilite bearings; oil well around each. 2 3/8-in. flat and double V-pulley. Holds grinding wheels up to 8x1 in. 9 A 6616—Shpg. wt. 12 lbs...\$4.50

99 AT 6723—Grinder head with 3/4-H.P. 1750 R.P.M. split phase 110-120-volt A.C. motor, 4 in. motor pulley and 3/8x36-in. V-belt. Shipping weight 36 pounds \$16.35

99 A 06619—Same as 9 A 6616 but with two vitrified 6x1-in. grinding wheels. Shpg. wt. 19 lbs...\$7.45

99 AT 6724—Same as 99 A 06619 but with 3/4-H.P. 1750 R.P.M. split phase 110-120-volt A.C. motor, 4 in. motor pulley and 3/8x36-inch V-belt. Shpg. wt. 43 lbs...\$19.30

CRAFTSMAN heavy duty Grinder

D 15 3/8x3/8-in. spindle, turned down to 3/8-in. at ends; takes up to 8x1 3/8-in. wheels with 3/8-in. arbor holes. Two combination pulleys for flat or V-belts. Oilite bearings with oil well around each. Idling pulley locks for double V-drive. Shipping weight 30 lbs. 99 A 06629—Grinder head only.....\$8.25

99 AT 6725—Grinder head with 3/4-H.P. 1750 R.P.M. split phase 110-120-volt A.C. motor, 4 in. motor pulley and 3/8x36-in. V-belt. Shipping weight 54 lbs...\$20.10

99 A 06631—Grinder head with 2 CRAFTSMAN vitrified grinding wheels, 8x1 3/8 in., and 5 1/2x3 1/8 in. vitrified sickle wheel. Shipping wt. 46 lbs.....\$15.10

99 AM 6726—Same as 99 A 06631 but with 3/4-H.P. 1750 R.P.M. split phase 115-volt A.C. motor, 4 in. motor pulley and 3/8x36-in. V-belt. Shpg. wt. 70 lbs...\$26.90

E 9 A 6420—Sickle Holder. For 99 T 06629. Aligns mower knives accurately. Shpg. wt. 6 lbs. 8 oz...\$2.60

F 9 A 6421—Guards. For 99 T 06629. 8-inch capacity. Shpg. wt. 9 lbs. 6 oz.....Pair \$2.70

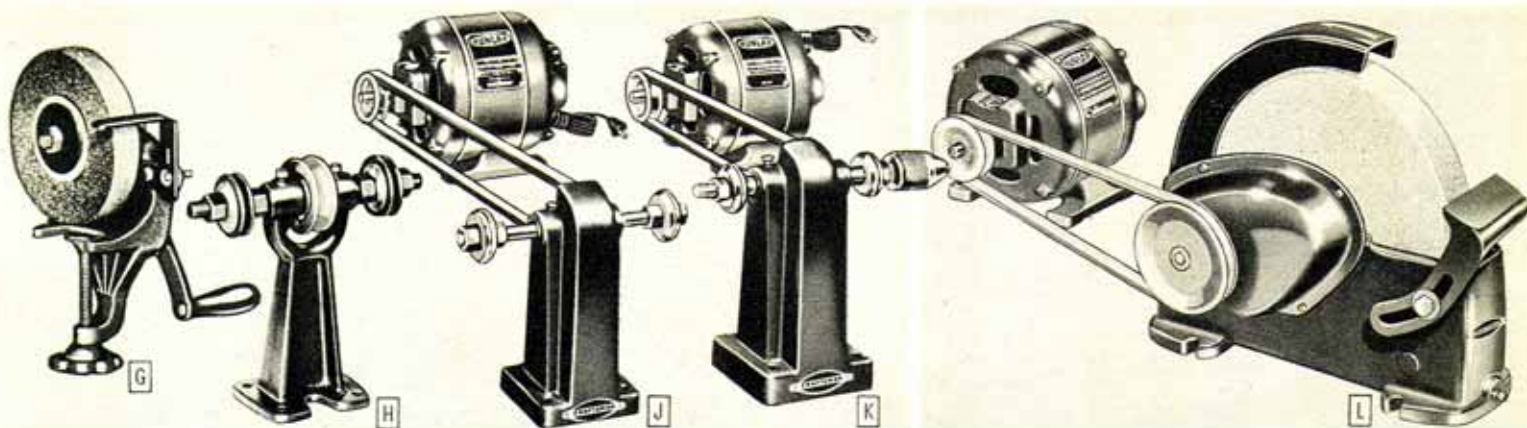

CRAFTSMAN Hand Grinder and Polishing Heads

G CRAFTSMAN Hand Grinder. Spur gear has 11 to 1 ratio. Dustproof, leakproof gear case. Spring covered oil cups. Horizontal and vertical tool rest adjustment; left or right hand. 6x1 inch vitrified aluminum oxide grinding wheel, medium grit. Gray enamel finish. 99 A 06626—Shpg. wt. 11 lbs.....\$5.95

H Low priced Polishing Head. Well-balanced. Sharpens tools, grinds, polishes, drills etc. when used with proper accessories. Head is 7 1/8 in. high; spindle is 7x3/8 in., 20 thread. Stamped steel collars. Oil plugs. Can be driven from rear, above or below. Two-inch V-pulley included. Shpg. wt. 3 lbs. 7 oz. 9 A 6615—Polishing Head.....\$2.25

Heavy cast iron frames finished in gray enamel. Spindles are threaded 3/8-in., 20 thread for standard accessories. Oilite bronze bearings; oil well around each. Spring cap oil cups. Can be driven from below or behind. Handy all-purpose tool.

J CRAFTSMAN Polishing Head. Height 7 3/8 inches. Machined steel flanges. Two-inch V-belt pulley. Shipping weight 6 pounds. 9 A 6627—Polishing Head only.....\$3.50

99 AT 6657—Polishing head with 3/4-H.P. 1750 R.P.M. split phase 110-120-volt, 60-cycle A.C. motor, 4-in. motor pulley and 3/8x34-inch V-belt. Shipping weight 30 lbs.....\$15.30

K CRAFTSMAN heavy duty Polishing Head. Height 9 1/8 in. 3-jaw screw-on type chuck. 3/8-in. capacity. Machined steel collars. Two-in. pulley for 3/8 or 1/2-in. V-belt. Shipping wt. 9 lbs. 4 oz. 9 A 6647—Polishing Head only.....\$6.25

99 AT 6658—Polishing Head with 3/4-H.P. 1750 R.P.M. split phase 110-120-volt, 60-cycle A.C. motor, 4-in. motor pulley and 3/8x34 inch V-belt. Shipping weight 33 lbs.....\$18.00

CRAFTSMAN Wet Grindstone

L Extra heavy duty. Revolves in a bath of water... won't draw temper from tools. A sturdy power driven grindstone specially designed to stand up under heavy industrial use... that's why it'll do such a grand job in your shop.

Highest quality natural Ohio grindstone, 10 inch diameter, 1 1/2-inch face. Built-in gear train reduces stone to proper speed. Heavy cast iron body. Durable cast iron bearings. Adjustable 3-inch tool rest. Splash guard can be flipped back for grinding axe, etc. on top of stone. Drain plug in base. Rust-resisting gray enameled finish.

Comes with 4-inch drive pulley. Use 1 3/8-inch motor pulley with 1750 R.P.M. motor. Motor, V-belt and motor pulley are not included. Shipping weight 32 lbs. 99 A 06620—CRAFTSMAN Grindstone.....\$11.95

99 A 6627—CRAFTSMAN Grindstone with 3/4-H.P. 1750 R.P.M. split phase 115-volt, A.C. motor, 1 1/2-in. motor pulley and 3/8x36 inch V-belt. Shpg. wt. 58 lbs...\$23.45

9 A 6621—Replacement Stone only for above. Shipping weight 13 pounds.....\$3.95

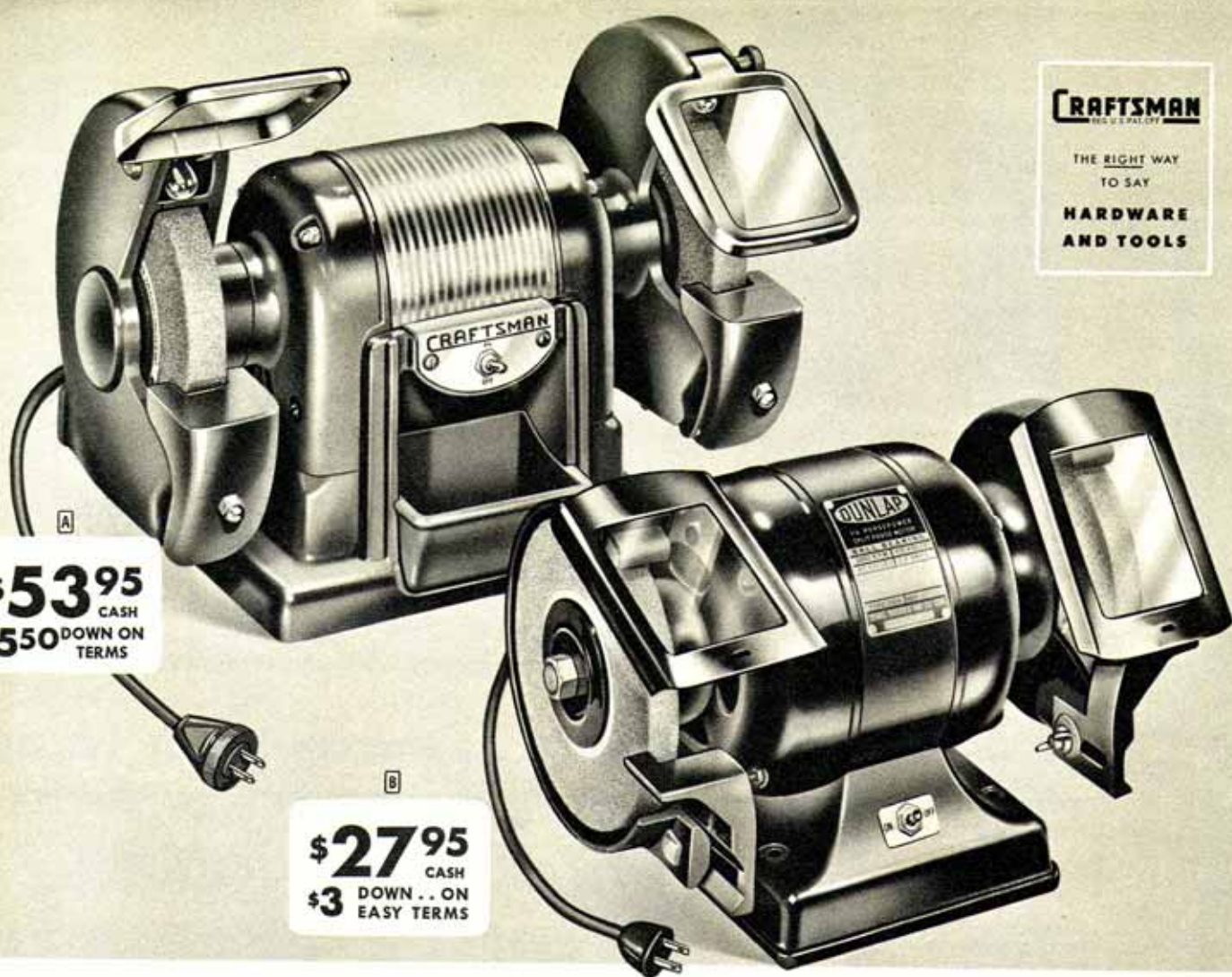
CRAFTSMAN
REG. U.S. PAT. OFF.THE RIGHT WAY
TO SAY**HARDWARE
AND TOOLS****\$53.95** CASH
\$550 DOWN ON
TERMS**\$27.95** CASH
\$3 DOWN .. ON
EASY TERMS

Precision built Grinders for your shop

CRAFTSMAN 1/3-H.P. Grinder

A completely new post-war model!

A An entirely new CRAFTSMAN ball bearing grinder . . . incorporating the latest and best in grinder design . . . made of finest materials by top flight tool builders! Excellent for heavy duty grinding and sharpening in garages, maintenance shops, tool rooms, workshops.

Note the rugged simplicity of design combining strength, utility and beauty. Heavy, rigid cast iron frame built for heavy duty service . . . made to take plenty of punishment! Rubber-mounted to absorb vibration. Finished in attractive CRAFTSMAN gray with contrasting chromium trim. Convenient removable built-in water pan of bright red plastic.

And there's power aplenty in this husky grinder! Ample overload capacity to meet unusual power demands without burning out motor. Precision built CRAFTSMAN 1/3-H.P. capacitor motor is condenser-start induction-run type . . . ideal for heavy duty service because it combines high starting torque with minimum current consumption while running. Dynamically balanced for smooth, vibration-free operation at 3450 R.P.M. Motor ventilation openings fully baffled for protection against dust, dirt, metal grindings and abrasive grit.

Operates on 110-120 volt, 60-cycle A.C. power. Toggle switch conveniently located at front of grinder. Eight-foot heavy rubber-covered power cord and unbreakable plug.

Smooth-running precision ball bearings assure minimum friction and wear . . . conserve power . . . prolong grinder life. Bearings are sealed against dirt, dust and grit. Strong steel shaft is 3/4-inch diameter, turned down to 3/8-inch at each end.

Now you can see what you're doing! Thanks to two 10-watt work lamps—one built into each wheel guard! With your work lighted, you can do more accurate grinding and sharpening. Lamps rubber-mounted to absorb vibration, increase filament life. Easily replaced.

Here's why you're safer with a CRAFTSMAN grinder! Each grinding wheel is fully enclosed by heavy cast iron wheel guard. You're protected in case of wheel breakage. Each guard is equipped with rear dust chute that leads away grindings and abrasive particles. Dust bags may be easily attached. Each wheel is covered with shatterproof glass eye shield, mounted in adjustable chromium plated die cast frame. Useful glass area of eye shield is 3 1/4 x 3 3/4 inches; outer dimensions of frame 4 1/2 x 4 3/4 inches. Ground cast iron tool rests adjustable for wheel wear and proper grinding position.

Two finest industrial quality CRAFTSMAN vitrified aluminum oxide grinding wheels . . . one 36 grit for coarse grinding and one 70 grit for fine grinding and finishing. Wheel diameter greater than motor diameter for grinding work across face of machine. Both wheels 7 inches in diameter, 1 inch thick. Thirteen-inch clearance between wheels. Each wheel scientifically bonded and vitrified in electrically controlled furnaces. Face and sides dressed square. Perfectly balanced. Operate safely at rated speed of 3450 R.P.M. Dimensions (without eye shields and tool rests): Height 12 inches; width 17 inches; depth 8 3/4 inches.

99 AM 2618—CRAFTSMAN 1/3-H.P. ball bearing Grinder. Shipping weight 98 lbs. **\$53.95**

DUNLAP 1/4-H.P. Grinder

Dependable quality...low in price!

B Designed and constructed to handle most grinding jobs in small shops and for general maintenance work. An excellent utility grinder for any shop. Smaller and less expensive than our CRAFTSMAN 1/3-H.P. model at the left. Built to give years of trouble-free service.

Equipped with 1/4-H.P. DUNLAP split phase motor that operates on 110-120 volts 60-cycle A.C. power. Rated speed is 3450 R.P.M. Built-in on-off toggle switch is conveniently located at front of grinder. Eight-foot rubber-covered cord and unbreakable plug.

Precision ball bearings, protected against dirt, dust, grindings and abrasive particles. You get smooth, dependable, vibration-free operation with minimum power loss due to friction. The 3/4-inch steel shaft is turned down to 3/8-inch at wheel ends.

Two 6 x 3/4-inch fully vitrified CRAFTSMAN grinding wheels—one 36 grit wheel for coarse grinding and one 70 grit wheel for finer grinding and finishing. Clearance between wheels is eleven inches. Wheels are made of finest aluminum oxide grit, bonded and vitrified in electrically controlled furnaces. Well balanced . . . true running . . . made to cut cool, and fast. Operates safely at rated grinder speed of 3450 R.P.M.

Cast iron wheel guards protect you against injury due to wheel breakage. Shatterproof glass eye shields in adjustable steel frames protect you against flying particles and sparks from grinding wheels. Useful glass area of eye shields 3 1/2 x 4 inches; outer dimensions of eye shield frames is 4 x 5 3/4 inches. Removable, adjustable tool rests steady your work . . . assure greater accuracy.

Durable cast iron frame for strength and rigidity. Finished in gray enamel. Rubber-mounted for freedom from vibration.

Over-all dimensions (without eye shields and tool rests): Height 8 3/4 inches; width 12 3/4 inches; depth 8 inches.

99 A 02616—DUNLAP 1/4-H.P. Grinder. Shipping weight 43 lbs. . . . **\$27.95**

Yes, you can buy your grinder on Easy Terms!

Find yourself a little short on cash? Stop worrying! Here's how you can put a new grinder in your shop NOW . . . pay for it as you use it. Only 10% down on Sears Easy Terms . . . balance in convenient monthly payments. If you already have a Sears Easy Terms account, just add your grinder to your present account. See inside front cover for complete details.

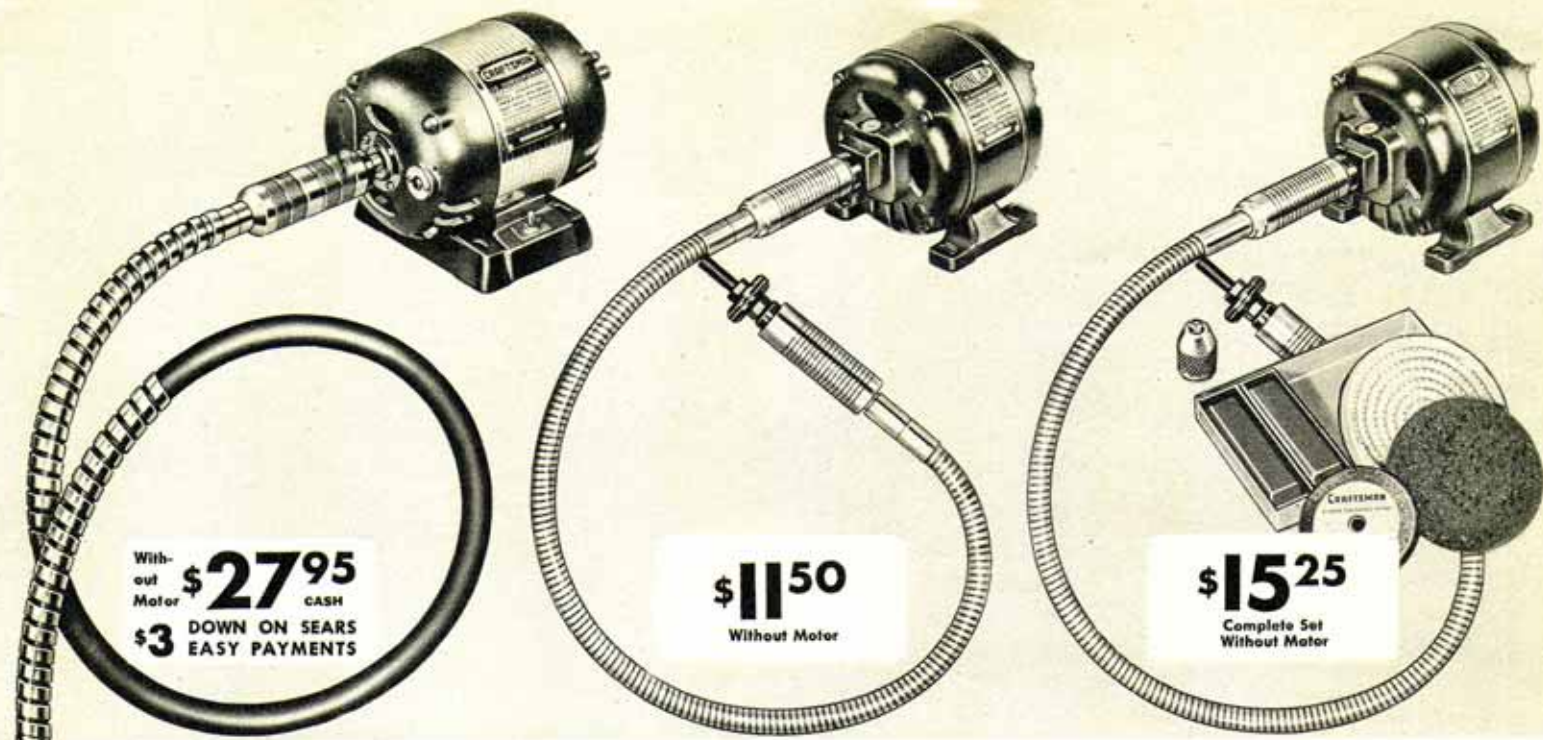

CRAFTSMAN Flexible Shafts . . many tools in one

Construction features below show why you get superior performance

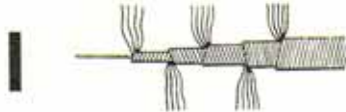

1 Cores of helically wound, high carbon steel wire (47 wires, 6 layers in 50-inch shaft; 55 wires, 7 layers in 72-inch shaft) have tensile strength of 240,000 to 270,000 pounds per square inch



2 50-in. shaft casing has inner layer of wear-resistant spring steel. Outer layer of soft steel resists lubrication leakage; also resists rust. Makes shaft more flexible . . . run smoother

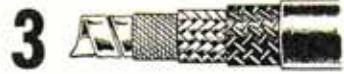

3 72-in. casing has liner of spiral steel with oil-resistant fabric jacket and rust-resistant double braided steel wire. Tough Neoprene rubber cover is cotton reinforced. Long wearing spiral steel shaft end reinforcement

CRAFTSMAN 72-inch Flexible Shaft

Extra long . . . and tough. Ideal for heavy duty use in garages, shops, factories and industrial plants.

Chrome plated steel hand piece and motor coupling both have extra large precision ball bearings for smoother operation and longer wear. Knurling on hand piece gives firm, non-slip grip. Black, rust resistant plated, steel end fittings.

Extra long, 72-inch shaft. Fits 3/4-inch motor shaft. Spindle is 1/2-inch, 20-thread. Core is made of 3/4-inch high carbon steel wire, helically-wound, multiple-strand. Inner casing is made of helically wound steel, covered with heavy, abrasion-resistant, rubber jacket . . . steel impregnated . . . will not scratch surfaces.

Unusually flexible! Absolutely leakproof! Supports core evenly. The spiral steel chrome finish outer reinforcement at end of shaft protects jacket. Complete with casing, core, motor coupling, hand piece and simple instructions for correct use.

99 A 02627—CRAFTSMAN 72-inch Flexible Shaft without motor. Shipping weight 11 lbs. . . . \$27.95

99 A 02629—CRAFTSMAN 72-inch Flexible shaft with 3/4 H.P. 1750 R.P.M. capacitor ball bearing motor for 110-120 volt 60 cycle A.C. Shpg. wt. 46 lbs. . . \$55.90

9 A 2626—Extra Core for above flexible shafts. Shipping weight 2 pounds 5.95

CRAFTSMAN 50-inch Flexible Shaft

General purpose flexible shaft that has hundreds of uses in the home, garage or repair shop. It's smooth . . . quiet running . . . and transmits power from motor to driven tool with minimum power loss.

50 inches long. Fits any 1/2-inch motor shaft. Smooth operating, ball bearing hand piece, with 1/2-inch 20-thread spindle. The motor coupling runs on needle bearings. Hand piece and motor coupling are made of non-rusting aluminum alloy.

Two layers of steel in casing. Inner layer is tempered spring steel and outer layer is soft steel. Practically leakproof. 3/8-inch core is made of helically-wound high carbon steel wire. Complete with casing, core, motor coupling, hand piece and instructions. 99 A 02633—CRAFTSMAN 50-inch Flexible Shaft without motor. Shipping weight 5 lbs. . . \$11.50

99 A 02619—CRAFTSMAN 50-inch Shaft with 1/4 H.P. 1750 R.P.M. sleeve bearing split phase motor for 110-120 volt 60 cycle A.C. Shpg. wt. 29 lbs. . . . \$22.00

9 A 2634—Flexible Shaft Extension (not shown). 38 inches long. Same construction as above flexible shaft. Without hand piece or motor coupling. Shipping weight 3 pounds 6 ounces. . . . \$3.95

9 A 2622—Extra Core for above flexible shaft or extension. Shipping weight 1 pound. 2.60

CRAFTSMAN 50-in. Flexible Shaft Set

Makes grinding, sanding, cleaning, polishing, drilling, and rust removal far easier. Set includes:

Flexible Shaft. 50 inches long over-all; fits 1/2-inch motor shaft. Casing has 2 layers of steel consisting of an inner layer of tempered spring steel and an outer layer of soft steel. Ball bearings in hand piece; needle bearings in motor coupling. Aluminum alloy housings. Black, rust-resistant plated, steel end fittings. Has 3/8-inch core of multiple-strand, helically-wound high carbon steel wires. Spindle is 1/2-inch by 20-thread.

Motor. DUNLAP 1/4-H.P. 1750 R.P.M. sleeve bearing split-phase for 115 volt 60-cycle A.C.

Buffing Equipment. 6-in. double-thickness sewed buff; 6-oz. bar of rouge buffing compound for soft, nonferrous metals; 5-oz. bar of Tripoli (brown) buffing compound for aluminum, brass, wood, plastics, etc. Also 4-in. rubber and abrasive polishing wheel, 3/4 in. thick, 3/4-in. bore; 5 1/2-in. flexible sanding plate with medium grit abrasive; 3-jaw chuck, screw-on type, 3/4-in. capacity.

99 A 02651—Complete set, with motor. Shipping weight 33 pounds. \$25.75

99 A 02630—Complete set, without motor. Shipping weight 8 pounds 10 ounces. 15.25

Flexible Shaft Accessories

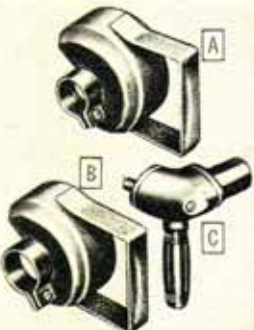

A CRAFTSMAN Wheel Guard. Protects hands and eyes from danger of flying particles and grit. Fits 99 A 02633 and 99 A 02619 (listed above) or any flexible shaft with 1 1/8-inch diameter hand piece. Hand guard. Use with any 4-inch grinding wheel or wire wheel. 9 A 2637—Shipping weight 2 lbs. 4 oz. \$3.70

B CRAFTSMAN Wheel Guard. Made to fit 99 A 02627 and 99 A 02629 (listed above) or any flexible shaft with 1 1/4-inch diameter hand piece. Has hand guard. For use with 4-inch grinding wheel or wire wheel. 9 A 2638—Shipping weight 2 lbs. 4 oz. \$3.70

C CRAFTSMAN Angle Head. Ideal for getting into tight places, for putting more pressure on grinding wheels, brushes, sanding and polishing discs. Cast aluminum head. Ball bearings take thrust; needle bearings radial load. 1-to-1 gear ratio. Removable rubber grip handle. Use on 99A 02627 and 99A 02629 (listed above). 9 A 2628—Shipping weight 2 lbs. 8 oz. \$30.50



Grinding Tools

Mounted grinding tools for use on flexible shafts. Points made of highest quality vitrified aluminum oxide. Accurately mounted on 1/4-inch steel shafts; run true. For finish work, die cutting, or other grinding work. Sizes given are stone sizes. Use 9 A 6458 for sharpening 9 A 2420 hollow chisel (page 19). Shipping weight, each, 3 ounces.

Catalog No.	Diameter	Length	Each
D 9 A 6461	3/8 in.	2 1/2 in.	55c
E 9 A 6463	3/8 in.	2 in.	55c
F 9 A 6462	3/8 in.	2 in.	55c
G 9 A 6459	1 in.	1 in.	55c
H 9 A 6458	1 1/4 in.	1 1/4 in.	55c
J 9 A 6457	3/8 in.	1 1/16 in.	55c
K 9 A 6460	1 in.	1 in.	55c
L 9 A 6443	1 in.	1 1/2 in.	45c
M 9 A 6444	1 1/4 in.	1 1/2 in.	45c



\$21⁹⁵
CASH
\$2.50 DOWN... ON
EASY TERMS

CRAFTSMAN Rotary Electric Tool

Hundreds of uses in every industrial or home workshop

Expert craftsmen, hobbyists—even novices will get a real thrill from using this CRAFTSMAN Rotary Electric Tool. You'll be able to turn out fine work quickly and easily. Excellent for toolroom and light production work. Use this tool for grinding, drilling, routing, carving, sawing, polishing, sanding, cutting and engraving on wood, metal, glass, leather, plastic, etc. It's a whole shop-full of tools in one.

Lightweight and convenient. Weighs 1 $\frac{3}{4}$ pounds, less cord. Pistol grip handle is readily removable. Finger rest over chuck. Balances in hand for comfortable use. Handy ripping guide and depth of cut gauge.

Powerful construction. Accurate chuck with two collet inserts (capacity $\frac{1}{8}$ to $\frac{3}{32}$ in.) assures solid locking of accessories. Has grease-packed precision

ball bearing in front and self-aligning bronze bearing in rear. Fan-cooled motor has balanced armature; built-up commutator. Built-in condenser reduces radio interference. Actually has 50% more power than many higher priced tools on the market today. Approved by Underwriters' Laboratories, Inc.

SPECIFICATIONS:

- Over-all length..... 7 inches
- Extreme diameter..... 2 inches
- Barrel diameter..... 1 $\frac{1}{4}$ inches
- Bearings..... 1 bronze and 1 ball bearing
- Chuck capacity..... $\frac{3}{8}$ and $\frac{3}{32}$ inches
- Fan..... Induction rotor; 4 metal blades
- Speed..... 18,000 R.P.M.
- Insulation..... Tested at 1000 volts

- Motor..... Universal, 110-120-volt, 25-60-cycle, A.C. or D.C.
- Condenser..... Built-in
- Brushes..... Large size, replaceable from outside
- Switch..... Special design; positive break

The leader for completeness. 35 accessories assure great versatility. Set includes 1 each of all the accessories shown below plus extra mandrels, sanding sleeves and abrasive discs, 2 chuck wrenches, collet chuck, socket wrench, emery wheel dresser, set of motor replacement brushes and 5 $\frac{1}{2}$ -ft. rubber covered cord and plug... actually 52 pieces in all. All accessories and tool packed in lined, simulated leather covered workshop box as shown above.

9 A 2652—Shipping weight 3 lbs. 4 oz. **\$21.95**

Accessories for CRAFTSMAN Rotary Electric Tool



Cutters: For rapid and efficient work on soft metals such as aluminum, tin, lead, bronze, etc. Ideal for making delicate designs in soft or hard wood.

- A 9 A 2670—Oblong cutter, Diameter $\frac{3}{16}$ inch; $\frac{3}{8}$ inch long..... 59c
- B 9 A 2836—Ball cutter, Diameter $\frac{1}{16}$ inch..... 59c
- C 9 A 2671—Ball cutter, Diameter $\frac{1}{8}$ inch..... 59c

- D 9 A 2672—Cone cutter, Diameter $\frac{7}{32}$ inch..... 59c
- E 9 A 2673—Oval cutter, Diameter $\frac{7}{32}$ inch..... 59c
- F 9 A 2674—Flat cutter, Diameter $\frac{3}{32}$ inch; length $\frac{3}{16}$ inch..... 65c
- G 9 A 2837—Pointed cutter, Diameter $\frac{7}{64}$ inch..... 59c
- H 9 A 2656—Saw and Mandrel, Diameter $\frac{3}{8}$ inch. .032 inch thick..... 69c

High Speed Steel Drills. For use on wood, metals, plastics, etc.

- J 9 A 2689—Saw blade without mandrel, Diameter $\frac{3}{8}$ inch..... 39c
- K 9 A 2684—High speed drill, Diameter $\frac{1}{16}$ inch..... 35c
- L 9 A 2685—High speed drill, Diameter $\frac{3}{32}$ inch..... 35c
- M 9 A 2686—High speed drill, Diameter $\frac{1}{8}$ inch..... 35c

Brushes. Ideal for reaching hard-to-get at places, polishing, cleaning out cavities, and many other jobs. Expertly designed and made.

- N 9 A 2679—Disc type bristle brush, $\frac{3}{8}$ -inch diameter..... 15c
- P 9 A 2680—Cup type bristle brush, $\frac{3}{8}$ -inch diameter..... 15c
- R 9 A 2681—Mounted porte polishing brush, $\frac{3}{16}$ -inch diameter..... 15c

NOTE: The shipping weight for each of the above accessories for the CRAFTSMAN Rotary Electric Tool is 2 ounces



Mounted Emery Wheels. Ideal for shaping or for giving a fine, smooth finish to metal. Choice of sizes and shapes as shown for wide variety of jobs.

- S 9 A 2653—1-inch diameter; $\frac{3}{8}$ -inch thick..... 35c
- T 9 A 2654— $\frac{3}{8}$ -inch diameter; $\frac{3}{8}$ -inch long..... 35c
- U 9 A 2675— $\frac{3}{16}$ -inch diameter..... 29c
- V 9 A 2676— $\frac{1}{4}$ -inch taper emery wheel..... 29c

- W 9 A 2677— $\frac{3}{16}$ -inch diameter; $\frac{3}{8}$ -inch long..... 29c
- X 9 A 2678— $\frac{1}{4}$ -inch diameter; $\frac{3}{8}$ -inch long..... 29c
- Y 9 A 2831— $\frac{3}{8}$ -inch diameter; $\frac{1}{4}$ -inch long..... 29c
- Z 9 A 2832— $\frac{1}{4}$ -inch diameter; $\frac{3}{8}$ -inch long..... 29c

Polishing Wheels; Abrasive Drums, Discs.

- AA 9 A 2951—Set of 3 buffing wheels, $1\frac{1}{4}$ -inch diameter..... 35c

- BB 9 A 2977—Set of three felt buffers, 1-inch diameter..... 35c
- CC 9 A 2952—Set of three rubber-bonded polishing wheels, $\frac{3}{8}$ -inch diameter..... 29c
- DD 9 A 2953—Set of three knife-edge rubber taper wheels, $\frac{3}{8}$ -inch diameter..... 29c
- EE 9 A 2696—Mounted sanding drum assembly with sanding sleeve, $\frac{3}{8}$ -inch diameter; $\frac{3}{8}$ -inch width..... 39c

NOTE: Shipping weight of above CRAFTSMAN Rotary Tool accessories is 2 ounces each.

- FF 9 A 2699—Set of four replacement sanding sleeves for above sanding drum assembly..... 25c
- GG 9 A 2691—Set of 12 silicon carbide discs, 1-inch diameter; $\frac{1}{4}$ -inch thick. Mounting hole size $\frac{1}{16}$ -inch diameter..... 29c

- Mandrels.** Made of steel. Ideal for mounting various accessories above.
- HH 9 A 2666—Nut and collar type..... 17c
- JJ 9 A 2667—Screw-in-end type..... 17c

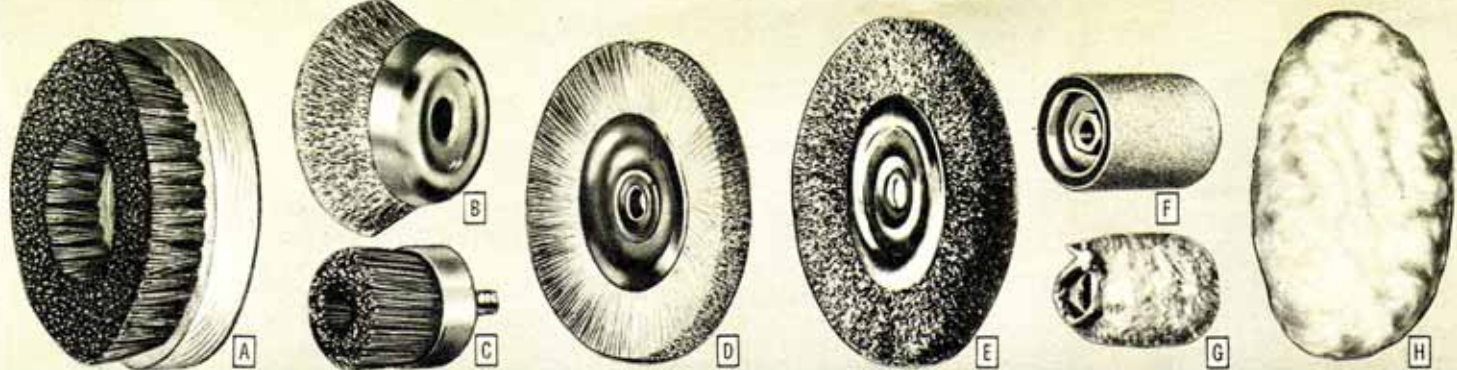

Accessories for lathes, polishing heads, flexible shafts

Floor Brush

A Very handy for scrubbing, waxing, etc. 1-inch long Tampico fibers are closely and securely set in a 6-inch diameter hardwood block. Has $\frac{1}{2}$ -inch arbor hole for mounting on lathe, polishing head, flexible shaft, or any $\frac{1}{2}$ -inch spindle.
9 A 6487—Shipping weight 11 ounces.... Each \$1.10

Wire Cup Brush

B Densely filled with special crimped steel wire bristles, $1\frac{1}{2}$ inches long, evenly distributed and rigidly secured in a heavy cup shaped metal holder. Designed for high speed operation on portable or stationary equipment. Recommended for removing scale, rust, paint or weld spatter from rough metal surfaces. Brushing surface has $1\frac{1}{2}$ -in. face. $2\frac{3}{4}$ -in. outside diameter; $\frac{1}{2}$ -in. arbor hole.
9 A 6485—Shipping weight 4 ounces..... 75c

Carbon Removing Brush

C Used by auto mechanics for hard-to-get-at jobs such as carbon removing, brushing motor parts, engine heads, castings of irregular shape, etc. The 1-inch long, straight, tempered steel wires are rigidly secured in sturdy metal holder. Ferrule diameter 1 inch; $\frac{1}{4}$ -inch diameter steel shank.
9 A 6484—Shipping weight 4 ounces..... Each 69c

Tampico Fiber Wheel Brush

D Tampico fiber secured by metal center. Diameter 6 inches; $\frac{3}{4}$ -inch face; $\frac{1}{2}$ -inch arbor hole.
9 A 6486—Shipping weight 8 ounces..... Each 69c

Steel Wire Wheel Brushes

E Crimped steel wire; metal center. Order by catalog number, stating wheel diameter and arbor hole size.

Diameter	Face Width	Center Hole	Shipping weight	Each
9 A 6480—Coarse. Made from No. 33 wire				
4 inch	$\frac{1}{2}$ -inch	$\frac{1}{2}$ -inch	5 oz.	\$.52
6 inch	$\frac{3}{4}$ -inch	$\frac{1}{2}$ -inch	11 oz.	.69
6 inch	$\frac{3}{4}$ -inch	$\frac{3}{4}$ -inch	11 oz.	.69
8 inch	$1\frac{1}{4}$ -inch	$\frac{1}{2}$ -inch	1 lb.	.89
8 inch	$1\frac{1}{4}$ -inch	$\frac{3}{4}$ -inch	1 lb.	.89

9 A 6482—Fine. Made from .006-inch diameter wire				
4 inch	$\frac{3}{4}$ -inch	$\frac{1}{2}$ -inch	5 oz.	\$.65
6 inch	$\frac{3}{4}$ -inch	$\frac{1}{2}$ -inch	11 oz.	.89
6 inch	$\frac{3}{4}$ -inch	$\frac{3}{4}$ -inch	11 oz.	.89
8 inch	$\frac{3}{4}$ -inch	$\frac{1}{2}$ -inch	1 lb.	1.20
8 inch	$\frac{3}{4}$ -inch	$\frac{3}{4}$ -inch	1 lb.	1.20

9 A 6483—Coarse. Heavy duty. Made from No. 33 wire				
4 inch	1 -inch	$\frac{1}{2}$ -inch	14 oz.	\$.160
6 inch	$1\frac{1}{2}$ -inch	$\frac{1}{2}$ -inch	1 lb. 12 oz.	2.20
6 inch	$1\frac{1}{2}$ -inch	$\frac{3}{4}$ -inch	1 lb. 12 oz.	2.20
8 inch	$1\frac{1}{2}$ -inch	$\frac{1}{2}$ -inch	2 lbs. 12 oz.	2.70
8 inch	$1\frac{1}{2}$ -inch	$\frac{3}{4}$ -inch	2 lbs. 12 oz.	2.70

Sanding Drums

F Complete with adapter and medium grit sleeve held tightly by expanding rubber drum. Diameter $2\frac{3}{4}$ in.; length 3 in. Shpg. wt. 12 oz.
9 A 2524—Fits $\frac{1}{2}$ -in. x20-thread shaft..... \$1.40
Replacement Sanding Sleeve. (Not illustrated.) For use on above sanding drum. Be sure to state grit wanted: fine, medium or coarse.
9 A 2522—Shpg. wt. 2 oz..... Each 14c

Lambswool Polishing Drum

G Made of lambswool; 1-inch pile. Diam. $2\frac{3}{4}$ in.; length 3 in. Slips over sanding drum above for polishing curved and irregular surfaces.
9 A 2533—Shipping weight 3 oz..... Each 75c

Lambswool Polishing Bonnets

H Fit over sanding plates. Polishes wax surfaces to a high finish. Shpg. wt. each 8 oz.
9 A 2527—Diameter 7 inches. Fits over $5\frac{1}{2}$ or 6-inch sanding plate. 1-inch pile..... Each \$1.00
9 A 2528—Diameter 8 inches. Fits over 7-inch sanding plate. $1\frac{1}{4}$ -inch pile..... Each 1.20
9 A 2529—Diameter 9 inches. Fits over 8-inch sanding plate. $1\frac{1}{4}$ -inch pile..... Each 1.50
Lambswool Polishing Discs. Fits on $\frac{1}{2}$ -inch spindle. Diameter 8 inches. Has $1\frac{1}{4}$ -inch pile of genuine lambswool. Polishes waxed surfaces to high lustre.
9 A 2529—Shpg. wt. each 8 oz..... Each \$1.30

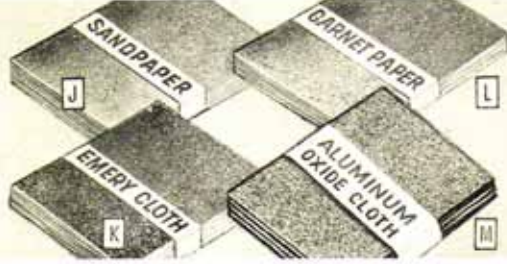

GRIT CHART

Grade	Approx. Grit	Flint or Sandpaper	Garnet Paper	Emery Cloth	Alum. Oxide Cloth
Extra fine	150	2/0	4/0	2/0	
Fine	120	1/0	3/0	3/0	
Medium fine	100	1/2	2/0	2/0	
Medium	80	1	1	1	
Medium coarse	60	1 1/2	1/2	1/2	
Coarse	40	2	1 1/2	1 1/2	

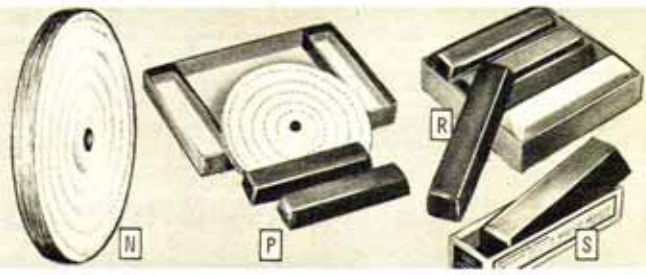

J Garnet Paper. Outlasts sandpaper.
9 A 6795—9x11 in. State grit.

Grit	Shpg. wt. 24	Each	24 for
4/0 Extra fine	1 lb.	7c.	\$1.19
3/0 Fine	1 lb. 1 oz.	7c.	1.19
2/0 Medium fine	1 lb. 4 oz.	7c.	1.19
0 Medium	1 lb. 8 oz.	7c.	1.29
1/2 Med. coarse	1 lb. 13 oz.	7c.	1.49
1 1/2 Coarse	2 lbs. 2 oz.	8c.	1.79

K Emery Cloth. Pkg. of 8 assorted sheets.
9 A 6799—4 1/2x5 1/2 in. Wt. 3 oz. 9c
9 A 6798—Three 9x11-in. sheets. 2/0 or 1/2 grit. State grit. Wt. 6 oz. 30c

L Assorted Grit Sandpaper. Handy package of 20 sheets; size 4 1/2x5 1/2 in.
9 A 6794—Shpg. wt. 6 oz. 9c
Packages of Sandpaper. 2, 3, 4 and 24-sheet packages. We do not break packages. Size of sheets 8 3/4x10 1/2 inches.
9 A 6793—State grit and size package

Grit	Shpg. wt. 24	24 for
00 Extra fine	1 lb.	4for10c. 55c
0 Fine	1 lb. 1 oz.	3 for 7c. 49c
3/2 Medium fine	1 lb. 4 oz.	3 for 7c. 49c
1 Medium	1 lb. 8 oz.	2 for 5c. 55c
1 1/2 Med. Coarse	1 lb. 13 oz.	2 for 5c. 55c
2 Coarse	2 lbs. 2 oz.	2 for 5c. 55c

M Aluminum Oxide Cloth. Sharper than garnet. 9x11 in. Shpg. wt. of 3, 6 oz.
9 A 6789—State grit and size package.

Grit	3 for	24 for
3/0 Fine	45c.	\$3.25
2/0 Medium Fine	45c.	3.25
0 Medium	45c.	3.25
1/2 Medium Coarse	45c.	3.25

Grits of Abrasive Papers and their Uses

1. Use coarse, medium-coarse and medium grit for fast removal of material.
2. Use medium-fine and fine grit for semi-finishing and light removal of material.
3. Use extra-fine grit for finishing and polishing.

CRAFTSMAN Buffing Wheels. Highest quality full discs that will last longer and stand up better under high speeds. Every ply made from one-piece of high grade muslin. Raked edges. Each buff expertly trimmed and balanced. Available in spiral-sewed or loose buff.

N Spiral-sewed Buffs. Made from full disc unbleached muslin 64x64 thread count. The most generally used type of buff for all classes of work. State diameter.

Cat. no.	Diam.	Center Hole	Layers	Shpg. wt.	Each
9 A 6491	4 in.	1/2 in.	18	2 oz.	\$0.29
Single Thick-ness Buffs	6 in.	1/2 in.	18	3 oz.	.47
	8 in.	1/2 in.	18	6 oz.	.69
9 A 6493	4 in.	1/2 in.	32	2 oz.	.47
	6 in.	1/2 in.	32	4 oz.	.69
	8 in.	1/2 in.	32	7 oz.	1.20

Loose Buffs. Same high quality as above buffs. Rows of sewing indicated are concentric. Easily removed. For use on base metals, plastics and plated surfaces to give light cut and high finish. State diameter.

Catalog number	Diameter	Center Hole	Rows of Sewing	Layers	Shpg. wt.	Each
9 A 6494	4 in.	1/2 in.	2	32	2 oz.	\$.40
	6 in.	1/2 in.	2	32	4 oz.	.67
	8 in.	1/2 in.	3	32	7 oz.	1.08

Note: You can do a better job if you use the correct buffing compound on your buffing wheels. At the right you will find a complete assortment of buffing compounds for use on most metals and plastics. Order yours today.

P CRAFTSMAN Buffing Set. Set includes one 6-inch double thickness sewed muslin buffing wheel, with $\frac{1}{2}$ -inch center hole; one 6-ounce bar of rouge buffing compound; one 3-ounce bar of Tripoli brown buffing compound. Handy set for your shop.
9 A 2864—Shipping weight 1 pound 1 ounce..... Set 98c

R CRAFTSMAN Buffing Compound Set. Set includes one bar of the following compounds: Emery (black), Tripoli (brown), Red Rouge and White Rouge. Each bar $5\frac{1}{4}$ x $1\frac{1}{2}$ x1 inch; weighs 5 ounces.
9 A 2896—Shipping weight per set 2 pounds..... Set 65c

CRAFTSMAN Buffing Compound Bars. Sold individually. Each bar is $5\frac{1}{4}$ x $1\frac{1}{2}$ x1 inch in size. Actual weight of each bar 5 ounces. Shipping weight each, 8 ounces.

9 A 2850—White Rouge. Produces high luster on stainless steel, chromium, aluminum, etc. Per bar..... 22c
9 A 2865—All-purpose buffing compound. Produces gleaming luster on plastics as well as most metals. Per bar..... 22c

S CRAFTSMAN Buffing Compounds. Economical larger size bars. are $7\frac{1}{4}$ x $2\frac{1}{4}$ x $1\frac{1}{2}$ inches in size. Ideal size for industrial, hobby or work shop use. Made of highest quality materials. Each bar is individually packed in cardboard container.

9 A 2871—Emery. Black colored compound. Used to remove rust from tools, golf clubs, iron, etc. Actual weight of bar 1 pound. Shipping weight 1 pound 4 ounces..... Per bar 44c

9 A 2873—Tripoli. Brown colored compound. For use on aluminum, brass, copper, wood plastics, etc. Actual weight of bar 1 pound. Shipping weight 1 pound 4 ounces..... Per bar 44c

9 A 2874—Red Rouge. Ideal for giving brilliant luster to silver plate, gold, sterling and all soft metals. Actual weight of bar 1 lb. 3 oz. Shpg. wt. 1 lb. 8 oz..... Per bar 64c

9 A 2872—White Rouge. Ideal for giving shiny bright luster to stainless steel, cast brass, chromium, aluminum, etc. Actual weight per bar 1 lb. 3 oz. Shpg. wt. 1 lb. 8 oz..... Per bar 57c
9 A 2868—All-purpose buffing compound. Ideal for giving a high luster to plastics and most metals. Actual weight of bar 1 pound. Shipping weight 1 pound 4 ounces..... Per bar 55c



Accessories for Lathes, Sanders, Polishing Heads, etc.

Rubber-bonded Cut-off Wheels

- A** Aluminum oxide abrasive. 8-in. diam. by $\frac{1}{2}$ in. thick. For $\frac{1}{2}$, $\frac{3}{4}$ or $\frac{1}{2}$ in. shaft. 9 A 6470—State shaft. Shpg. wt. 1 lb. . . . \$1.29
- B** New Resinoid-Bonded Cut-Off Wheels. 8 in. diam., $\frac{1}{2}$ in. thick. For $\frac{1}{2}$, $\frac{3}{4}$ or $\frac{1}{2}$ in. shaft. State shaft diam. Shpg. wt. 1 lb. 9 A 6448—For steel sheets or tubing, etc. (aluminum oxide) Each \$1.39
9 A 6449—For tile, porcelain, etc. (silicon carbide) Each \$1.69
9 A 6455—For cast iron, brick, concrete, etc. (silicon carbide) Each \$1.69

Bayflex Abrasive Wheels

- C** Safest all purpose grinding wheel made. It's cotton felted, aluminum oxide impregnated and resinoid bonded. Use to replace hack saw, file, sharpening wheel or circular saw. 1-in. hole. Bushings furnished for smaller shafts. 9 A 6428—State diameter, grit and hole size

Diam.	Thickness	R.P.M.*	Grit	Shpg. wt.	Each
6 in.	$\frac{1}{2}$ in.	10,000	120	8 oz.	\$1.43
6 in.	$\frac{3}{8}$ in.	10,000	80	12 oz.	1.75
6 in.	$\frac{1}{2}$ in.	10,000	24	1 lb.	2.10
7 in.	$\frac{1}{2}$ in.	8,500	120	12 oz.	1.85
7 in.	$\frac{3}{8}$ in.	8,500	80	1 lb.	2.25
7 in.	$\frac{1}{2}$ in.	8,500	24	1 lb. 8 oz.	2.69
8 in.	$\frac{1}{2}$ in.	7,500	120	1 lb.	2.29
8 in.	$\frac{3}{8}$ in.	7,500	80	1 lb. 4 oz.	2.85
8 in.	$\frac{1}{2}$ in.	7,500	24	1 lb. 8 oz.	3.39
10 in.	$\frac{1}{2}$ in.	6,000	24	2 lbs.	5.25
10 in.	$\frac{3}{4}$ in.	6,000	24	3 lbs.	8.45

Rubber Polishing Wheel

- D** CRAFTSMAN. Made of rubber with the cutting abrasive distributed through it! For polishing and finishing all hard metals and plastics. Easy to shape for getting into difficult places. Ideal for rust removal, die work, deburring, putting a super-keen edge on knives, etc. $\frac{1}{2}$ -inch thick; $\frac{1}{2}$ -inch bore. Maximum speed recommended: 4-inch, 3800 R.P.M.; 6-inch, 2500 R.P.M. Choice of fine, medium or coarse grit. Please state grit wanted. 9 A 2928—4-inch diameter. Shipping weight 9 ounces. . . . \$1.10
9 A 2929—6-inch diameter. Shipping weight 1 lb. 8 oz. . . . \$1.90

- E** Disc Cement. Holds sanding discs to metal or wood sanding plates. Non-drying. Choice of $\frac{1}{4}$ or $\frac{1}{2}$ oz. sticks. 9 A 2219— $\frac{1}{4}$ oz. Shpg. wt. 6 oz. 30c
9 A 2229— $\frac{1}{2}$ oz. Shpg. wt. 18 oz. 70c

- F** Cement. Fastens abrasive discs to metal plates. Sets quickly; holds firm. Shpg. wt. 1 lb. 2 oz. 9 A 2535— $\frac{1}{2}$ -pint. 50c

Sanding Plates

Sanding Plates. Cast iron construction. Set screw provided to lock plate securely on spindle. Plate has one abrasive disc for sanding wood, attached. For extra abrasive discs see below. Be sure to check spindle size.

- G** 8-inch diameter. Fits woodworking lathe 99 A 02160 (see page 15) or any $\frac{1}{2}$ -in. straight unthreaded spindle. Shpg. wt. 2 lbs. 9 A 2341 \$3.75
- 8-inch diameter. Fits woodworking lathe 99 AM 2307 (see page 00) or any $\frac{3}{8}$ in. x 16 right hand thread spindle. Shpg. wt. 2 lbs. 8 oz. 9 A 2491 \$3.95

- H** Sanding Wheel. 8-in. diameter. $\frac{1}{2}$ or $\frac{3}{4}$ in. bore. Steel. Fits any 8-in. or larger bench saw, having $\frac{1}{2}$ or $\frac{3}{4}$ in. arbor. Has one medium and one coarse abrasive disc for wood, attached. State bore size. 9 A 2272—Shpg. wt. 4 lbs. . . . \$2.70

- Replacement Sanding Discs,** for 9 A 2272 above. 8-in. diameter. 2-in. center hole fits over any arbor. Package of six assorted: 2 each of fine, medium and coarse grit. 9 A 2273—Shpg. wt. 10 oz. . . . 60c

Flexible Sanding Plates

J Fit flexible shafts, polishing heads, lathes, electric hand drills, etc. or any other spindle with $\frac{1}{2}$ -inch x20 thread. One medium grit abrasive attached. For wood or metal. See below for replacement abrasives.

- $5\frac{1}{2}$ -inch diameter. $\frac{1}{2}$ -inch thick, flexible rubber pad, with $3\frac{1}{2}$ -inch diameter steel backing. Center-screw on hub keeps sanding disc from shifting. 9 A 2610—Shpg. wt. 13 oz. . . . \$1.75
- 7-inch diameter. $\frac{1}{2}$ -inch thick, flexible rubber pad, with $4\frac{1}{2}$ -inch diameter steel backing. Hub center-screw keeps sanding disc from shifting. Takes regular or resin-bonded discs below. 9 A 2611—Shipping weight 1 pound 5 ounces. \$2.50

- Replacement Sanding Discs.** Fit $5\frac{1}{2}$ and 7-inch flexible sanding plates shown above. Have medium grit abrasive. Ideal for use on wood or metal. Number 9 A 2612 replaces Sears old No. 2541; Number 9 A 2613 replaces Sears old No. 2545. 9 A 2612— $5\frac{1}{2}$ -inch diameter. Shipping weight 2 oz. Pair 32c
9 A 2613—7-inch diameter. Shipping weight 3 oz. Pair 48c

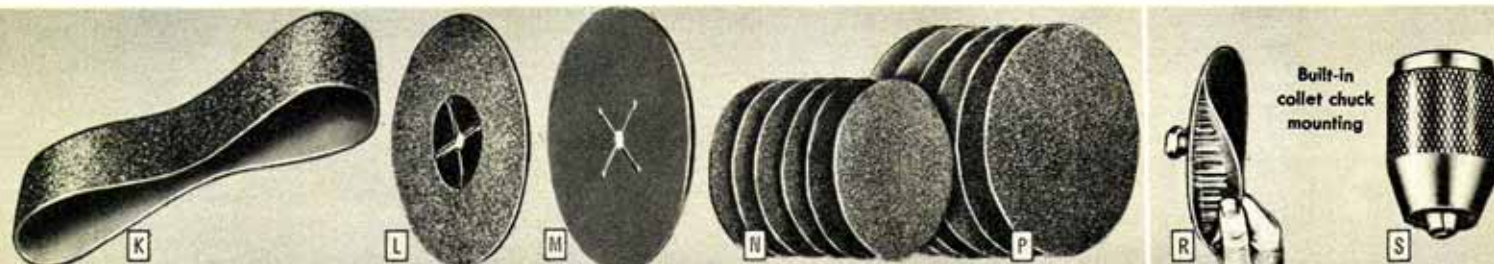

- K** Sanding Belts. Endless construction. For sanding wood or metal. In choice of fine, medium or coarse grit. State grit wanted when ordering. 9 A 2167—6x48 inches. Aluminum oxide on cloth. Fits 99 AM 2235 sander (see page 11). Shpg. wt. 8 oz. . . . \$1.15
9 A 2211—4x52 $\frac{1}{2}$ inches. Aluminum oxide on cloth. Fits Sears former No. 2210 sander. Shpg. wt. 10 oz. 80c
9 A 2215—4x36 inches. Aluminum oxide on cloth. Fits Sears former No. 2213 sander. Shpg. wt. 4 oz. 62c

- L** Resin-bonded Abrasive Discs. Outlast glue-bonded discs from 2 to 2 $\frac{1}{2}$ times! Won't "soften up" under high speeds. Fine for curved surfaces. Made of aluminum oxide grit, firmly bonded to pliable fiber back. 7-inch discs come in No. 24, 36, 50 or 80-grit; 9 $\frac{1}{2}$ -inch discs in No. 24, 36, or 50-grit. Please state grit wanted.

7-inch discs	Center hole	Shpg. wt.	Each
9 A 2220	$\frac{1}{2}$ inch	5 oz.	34c
9 A 2223	$\frac{3}{8}$ inch	8 oz.	34c
9 $\frac{1}{2}$ -in. discs	Center hole	Shpg. wt.	Each
9 A 2221	$\frac{1}{2}$ inch	6 oz.	44c
9 A 2224	$\frac{3}{8}$ inch	6 oz.	44c

- M** Fiber Backing Pads. Used for backing up abrasive discs for more rigidity. With $\frac{1}{2}$ or $\frac{3}{8}$ -inch center hole. Please state center hole size wanted. 9 A 2225—7-inch diameter. Shipping weight 4 oz. . . Each 59c
9 A 2226—9 $\frac{1}{2}$ -inch diameter. Shipping weight 5 oz. Each 72c

- N** Replacement Abrasive Sanding Discs. Made of aluminum oxide on paper. Ideal for sanding either wood or metal. Six discs of same grit size in package. Choice of fine, medium, or coarse grit. State grit size wanted. 9 A 2532—6-inch diameter. Shipping weight for package of six, 6 ounces. Package of 6 fine grit for 29c
Package of 6 medium grit for 32c
Package of 6 coarse grit for 39c

- P** 9 A 2525—8-inch diameter. Fits Sears former sander No. 2213 and 9 A 2341 and 9 A 2491 sanding plates above. Shipping weight per package, 8 ounces. Package of 6 fine grit for 47c
Package of 6 medium grit for 57c
Package of 6 coarse grit for 67c

- 9 A 2526—9-inch diameter. Fits Sears 99AM 2235 sander (see page 11). Shipping weight per package, 8 ounces. Package of 6 fine grit for 59c
Package of 6 medium grit for 69c
Package of 6 coarse grit for 85c
- 9 A 2534—10-inch diameter. Fits Sears former No. 2210 sander. Shipping weight per package 10 ounces. Package of 6 fine grit for 72c
Package of 6 medium grit for 85c
Package of 6 coarse grit for \$1.10

- R** CRAFTSMAN Quick-change Sanding Plate. Here is something really new! A sensational improvement! The abrasive discs are pre-glued with a new non-setting glue which permits instant change and immediate use . . . No mess gluing . . . No fuss . . . No bother . . . Just remove old disc and replace with new one. The old disc can be replaced later without regluing. All steel 7-inch diameter plate has rubber backing. Built-in collet chuck mounting fits any $\frac{1}{2}$ -inch shaft or spindle, either plain or threaded without spoiling or marring threads. Perfect for sanding, grinding or polishing wood, metal or plastic. Comes complete with one medium grit disc. 9 A 2549—Shipping weight 2 pounds. \$2.95

- 9 A 2546—Replacement Abrasive Discs for above fast-change sanding plate. 7-inch diameter. Pre-glued, ready to use. Choice of fine, medium or coarse grit. State grit wanted when ordering. Shipping weight 5 ounces. Pair 48c

- S** CRAFTSMAN quality 3-jaw Chucks . . . screw-on type. Hardened steel jaws. Precision made jaws center accurately to close tolerance. Knurled for firm grip. Check your spindle size before ordering. Tapped to fit $\frac{1}{2}$ -inch x20 thread spindles. 9 A 2248— $\frac{1}{4}$ -inch capacity. Shpg. wt. 5 oz. 70c
9 A 2243— $\frac{3}{8}$ -inch capacity. Shpg. wt. 12 oz. 90c
9 A 2256— $\frac{1}{2}$ -inch capacity. Shpg. wt. 12 oz. 98c

Everything Sears sells may be purchased on Easy Terms . . . See inside front cover for details



HOW TO MEASURE. Be sure to measure around the outside edge of pulleys (not in the groove) to get the correct length of V-belt needed.

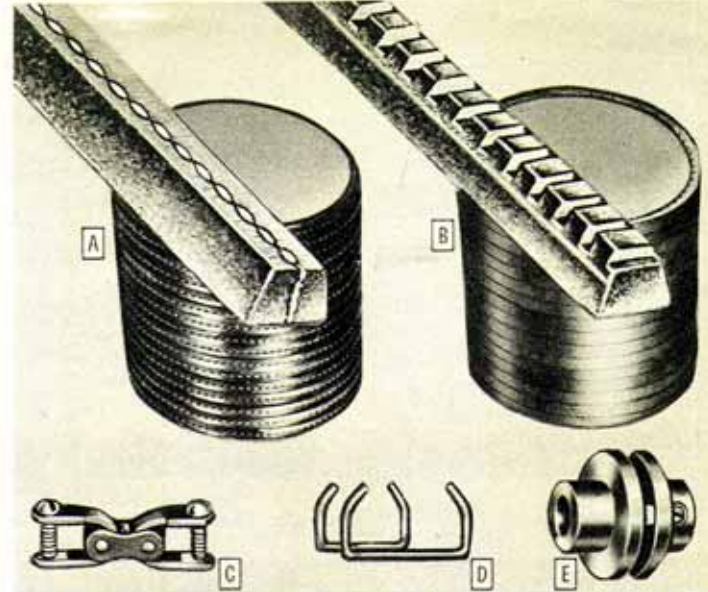

More pulling power, less frictional loss with **CRAFTSMAN V-Belts**

CRAFTSMAN V-Belts are expertly made from the finest materials available. Each belt has an extra heavy closely woven cotton jacket wrapped around pliable, heat resistant rubber. Reinforcing cords pre-treated in liquid rubber.

1/2-inch V-Belts



CRAFTSMAN quality. Correct size for most applications with V-pulleys, 2-inch diameter or larger. Be sure to see "How to Measure" ... explained above.

Catalog no.	Length	Shpg. wt.	Each
9 A 1622	22 in.	4 oz.	51c
9 A 1624	24 in.	4 oz.	52c
9 A 1625	25 in.	4 oz.	53c
9 A 1626	26 in.	4 oz.	54c
9 A 1628	28 in.	4 oz.	55c
9 A 1629	29 in.	4 oz.	56c
9 A 1630	30 in.	5 oz.	57c
9 A 1631	31 in.	5 oz.	58c
9 A 1632	32 in.	5 oz.	60c
9 A 1633	34 in.	5 oz.	62c
9 A 1634	35 in.	6 oz.	63c
9 A 1635	36 in.	6 oz.	64c
9 A 1636	37 in.	6 oz.	65c
9 A 1637	38 in.	7 oz.	67c
9 A 1638	39 in.	7 oz.	69c
9 A 1639	40 in.	7 oz.	71c
9 A 1640	41 in.	7 oz.	72c
9 A 1641	42 in.	7 oz.	75c
9 A 1642	43 in.	7 oz.	77c
9 A 1643	44 in.	7 oz.	79c
9 A 1644	45 in.	7 oz.	81c
9 A 1645	46 in.	7 oz.	82c
9 A 1646	47 in.	7 oz.	83c
9 A 1647	48 in.	7 oz.	84c
9 A 1648	49 in.	7 oz.	85c
9 A 1650	50 in.	7 oz.	88c
9 A 1651	51 in.	7 oz.	90c
9 A 1652	52 in.	7 oz.	92c
9 A 1654	54 in.	7 oz.	94c
9 A 1655	56 in.	8 oz.	97c
9 A 1658	58 in.	8 oz.	\$1.00
9 A 1660	60 in.	8 oz.	1.03
9 A 1662	62 in.	8 oz.	1.06
9 A 1664	64 in.	8 oz.	1.09
9 A 1666	66 in.	9 oz.	1.12
9 A 1684	84 in.	10 oz.	1.39
9 A 16100	100 in.	11 oz.	1.59

For Easy Terms see inside front cover

3/8-inch V-Belts



CRAFTSMAN quality. Correct size for use on drives over small diameter pulleys. Please be sure to see "How to Measure" ... explained above.

Cat. no.	Length	Shpg. wt.	Each
9 A 1520	20 in.	4 oz.	49c
9 A 1522	22 in.	4 oz.	50c
9 A 1524	24 in.	4 oz.	52c
9 A 1526	26 in.	4 oz.	53c
9 A 1528	28 in.	4 oz.	54c
9 A 1530	30 in.	4 oz.	55c
9 A 1532	32 in.	4 oz.	57c
9 A 1534	34 in.	4 oz.	60c
9 A 1536	36 in.	4 oz.	63c
9 A 1538	38 in.	4 oz.	65c

5/8-inch V-Belts



CRAFTSMAN quality. For heavier drives over minimum pulley diameter of 3 inches. Extra heavy duty. Machines perform at top efficiency.

Cat. no.	Length	Shpg. wt.	Each
9 A 1734	34 in.	5 oz.	79c
9 A 1736	36 in.	5 oz.	83c
9 A 1738	38 in.	5 oz.	87c
9 A 1740	40 in.	6 oz.	92c
9 A 1742	42 in.	6 oz.	98c
9 A 1743	43 in.	8 oz.	\$1.02
9 A 1744	44 in.	8 oz.	1.04
9 A 1746	46 in.	10 oz.	1.06
9 A 1750	50 in.	10 oz.	1.19
9 A 1752	52 in.	11 oz.	1.25
9 A 1754	54 in.	11 oz.	1.29
9 A 1771	71 in.	14 oz.	1.65
9 A 1778	78 in.	15 oz.	1.85
9 A 1788	88 in.	1 lb. 2 oz.	2.05
9 A 1793	93 in.	1 lb. 3 oz.	2.09
9 A 17100	100 in.	1 lb. 4 oz.	2.30
9 A 17108	108 in.	1 lb. 5 oz.	2.50

Leather V-Belting

A Use this fractional horsepower plain leather V-belt for rapid replacements on your power tools, and other machines. No need to remove machinery to replace belt. Made of two thick plies of tough, rugged oak-tanned leather cemented together and then sewn down the center. Steel wire hook is included with every length.

9 A 2777—Please be sure to state width and length wanted.

3/4-inch width. Shipping weight per foot 3 ounces. Per inch 2c

1/2-inch width. Shipping weight per foot 4 ounces. Per inch 3c

5/8-inch width. Shipping weight per foot 5 ounces. Per inch 3 1/2c

V-belt Couplers

C Here's the ideal way to shorten old leather V-belts or to couple together new ones. Coupler consists of roller chain link between two bails. Will not cause additional vibration. So simple and easy to install. Use for 1/2-inch, 3/4-inch or 5/8-inch V-belting.

9 A 2842—Shpg. wt. 1 oz. 25c

Wire V-Belt Hooks

D Simple and easy to use. Just punch holes into belt, insert hook and clinch. That's all there is to connecting leather V-belt sections when you use these convenient wire belt hooks. Made of tough steel music wire. Makes a safe dependable connection. Shpg. wt. of six 1 oz.

9 A 2847—State size wanted

Small size. For 1/2 or 3/4-inch belt. Each 1c

Large size. For 5/8 or 3/2-inch belt. Each 1c

Flexible Coupling

E The ideal coupling to use where motor is connected directly to a machine. This sturdy flexible coupling connects motor and machine shafts, and allows for slight misalignment between them. It helps prevent wear on the bearings which might result if a rigid coupling were used. Die cast metal construction. Accurately machined and well finished. Available for use with 1/2, 3/4 or 5/8 inch shafts. Please state bore size wanted when ordering. Shipping weight 12 ounces.

9 A 2840. Each 55c

Line Shaft Accessories . . accurately machined . . give long, efficient service

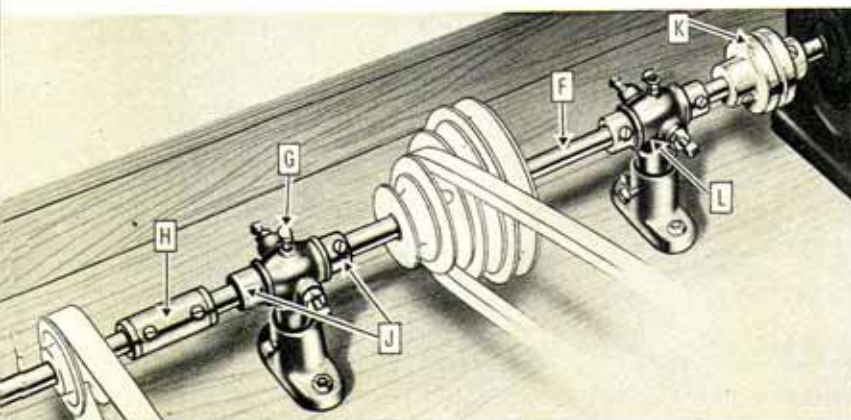

A line shaft is used to drive a group of power tools from one permanently mounted motor. In such a set-up, there is always some loss of power in the various belts and bearings. Consequently, we recommend a 1/2-H.P. motor or larger to drive tools from a line shaft.

Line shafts come in three sizes: 1/2-in. for light tools; 3/4 and 5/8 in. for heavier machines and larger motors. Oil cups easily installed in place of plugs. Rigid couplings are frequently used for connecting sections of line shafting. Line shaft collars prevent end-wise "drift" of shaft. Flexible couplings are used to connect motor shaft to a line shaft. Self-adjusting for slight misalignment. Bronze bearing hangers are adjustable to permit perfect shaft alignment. 1/2-in. hangers should be spaced every 18 inches; 3/4-in. hangers every 24 inches.

When your line shaft is set up, oil freely and be sure it is perfectly in line and turns easily before turning on motor.

Catalog number		Shpg. wt.	Each
9 A 2833	1/2-inch x 24-inch Steel Shaft	1 lb. 15 oz.	\$0.38
99 A 02834	1/2-inch x 48-inch Steel Shaft	3 lbs.	.68
99 A 02830	3/8-inch x 48-inch Steel Shaft	5 lbs.	.98
99 A 02835	3/4-inch x 48-inch Steel Shaft	7 lbs.	1.38
9 A 2820	Oil Cups	1 oz.	.07
9 A 2839	1/2-inch Rigid Coupling	5 oz.	.35
9 A 2824	1/2-inch Line Shaft Collar	2 oz.	.12
9 A 2825	3/4-inch Line Shaft Collar	3 oz.	.19
9 A 2840	Flexible Coupling (Specify 1/2, 3/4 or 5/8 inch)	12 oz.	.60
9 A 2828	1/2-inch Bronze bearing Shaft Hanger	1 lb. 8 oz.	1.60
9 A 2829	3/4-inch Bronze bearing Shaft Hanger	1 lb. 12 oz.	1.95

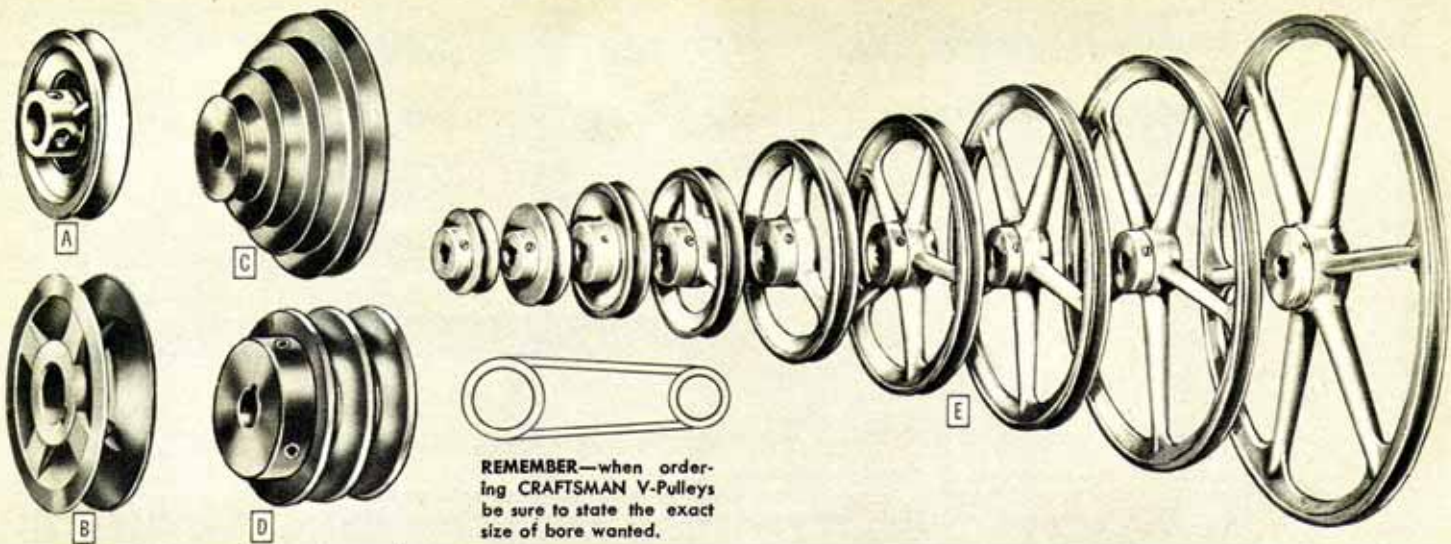

REMEMBER—when ordering CRAFTSMAN V-Pulleys be sure to state the exact size of bore wanted.

CRAFTSMAN V-Pulleys are available for most power tools

CRAFTSMAN pulleys are scientifically designed for greatest working efficiency and are carefully and accurately made to give you top working performance from your machinery or power tools. All the belt grooves are painstakingly machined to run true. All bores are reamed to exact size. Diameters given in the table listings below refer to outer edge of pulleys, not to bottom of the groove. Before ordering, carefully check diameter and bore size wanted.

CRAFTSMAN single groove V-Pulleys

A Made of tough alloy die cast metal. Strong flanges and hubs; machined grooves and reamed bores. Two slotted head, hardened setscrews insure positive locking of pulley on shaft. For $\frac{3}{8}$ -(O section) or $\frac{1}{2}$ -(A section) inch wide V-belts, except 9A2800, which is for use with $\frac{3}{8}$ -(O section) inch belt only. State bore size.

Cat. No.	Diam.	Bore, inch	Shpg. wt.	Each
9 A 2800	1½ in.	½	3 oz.	38c
9 A 2801	2 in.	¾	5 oz.	43c
9 A 2802	2½ in.	¾	6 oz.	49c
9 A 2803	3 in.	¾	7 oz.	56c
9 A 2804	4 in.	¾	10 oz.	70c
9 A 2805	5 in.	¾	15 oz.	85c
9 A 2806	6½ in.	¾	1 lb. 6 oz.	\$1.25

CRAFTSMAN hubless V-Pulleys

B Permit use of pulleys side by side for multiple drives. Sturdily built of tough alloy die cast metal. Machined grooves and reamed bores. Two slotted head, hardened setscrews lock pulley on shaft. For $\frac{3}{8}$ -(O section) or $\frac{1}{2}$ -(A section) inch wide V-belts. State bore size.

Cat. No.	Diam.	Bore	Shpg. wt.	Each
9 A 2901	2 inches	¾, ¾ inch	6 ounces	50c
9 A 2902	2½ inches	¾, ¾ inch	9 ounces	59c
9 A 2903	3 inches	¾, ¾ inch	11 ounces	69c

CRAFTSMAN cone type V-Pulleys

C Use in pairs for variable speed applications. Made of tough alloy die cast metal. Three and four step. Two slotted head hardened setscrews lock pulley on shaft. For $\frac{3}{8}$ -(O section) or $\frac{1}{2}$ -(A section) inch wide V-belts. Have ½, ¾ or ¾-inch bore. State bore size.

Cat. No.	Size	Diam., step, in.	Shpg. wt.	Each
9 A 2788	3¾ in.	3¾, 2¾, 2	1 lb.	\$1.15
9 A 2792	4 in.	4, 3¾, 2¾, 2	1 lb. 10 oz.	1.40
9 A 2793	5 in.	5, 4, 3, 2	1 lb. 14 oz.	1.65

CRAFTSMAN two-groove V-Pulleys

D Made of heavy cast iron. Balanced and true running, strong enough for heavy production work. Use on electric motors or gas engines on industrial, farm, workshop or household machines. Standard keyways provided in all bores listed in table below. Two hardened, hollow head setscrews. With wrench. For V-belts $\frac{3}{8}$ (A section) or $\frac{1}{2}$ (B section) inch wide. State bore size wanted.

Cat. No.	Diam.	Bore, inch	Shpg. wt.	Each
9 A 2940	3 in.	¾, ¾, 1	2 lbs. 11 oz.	\$2.95
9 A 2941	4 in.	¾, ¾, 1	4 lbs. 1 oz.	3.65
9 A 2942	5 in.	¾, 1, 1½	4 lbs. 9 oz.	4.10
9 A 2943	6 in.	¾, 1, 1½	6 lbs. 6 oz.	4.75
9 A 2944	8 in.	1, 1½, 1½	9 lbs. 11 oz.	6.00
9 A 2945	10 in.	1, 1½, 1½	11 lbs. 8 oz.	7.10
9 A 2946	12 in.	1, 1½, 1½	13 lbs. 15 oz.	8.45

CRAFTSMAN single-groove V-Pulleys

E Made of heavy cast iron. Heavy duty for production work in the shop, household or on the farm. Use to replace single groove V-pulleys on any type electric motor or gas engine. Positive grip grooves are expertly machined and bores are accurately reamed. CRAFTSMAN single groove V-pulleys have slotted-head, hardened setscrew. Standard keyways in ¾-inch or larger bores. The grooves fit V-belts ¾-inch (O section) or ½-inch (A section) wide. Order by catalog number and please remember to state clearly the size of bore which you require.

Cat. No.	Diam.	Bore, inch	Shpg. wt.	Each
9 A 2880	1½ in.	¾	9 oz.	55c
9 A 2881	2 in.	¾	11 oz.	58c
9 A 2882	2½ in.	¾	15 oz.	65c
9 A 2883	3 in.	¾	1 lb. 7 oz.	80c
9 A 2884	4 in.	¾	2 lbs. 3 oz.	\$1.10
9 A 2885	5 in.	¾	2 lbs. 7 oz.	1.20
9 A 2886	6½ in.	¾	3 lbs.	1.40
9 A 2808	8 in.	¾	3 lbs. 15 oz.	1.75
9 A 2810	10 in.	¾	4 lbs. 7 oz.	2.05
9 A 2812	12 in.	¾	5 lbs. 11 oz.	2.60
9 A 2814	15 in.	¾	9 lbs. 11 oz.	5.25

CRAFTSMAN Pulleys and V-Belts save you time and money! They transmit maximum power with minimum friction loss and slippage... less vibration and faster pickup. Use CRAFTSMAN single or double groove V-pulleys on bench saws, band saws, builders saws, etc. CRAFTSMAN cone type V-pulleys give multiple speeds when used in pairs on jig saws, lathes, etc.

Table of Pulley Speeds

Use this table to determine the speed of your machine with varying sizes of motor and machine pulleys. Figures given are for use with belt at proper tension and a standard motor speed of 1750 R.P.M.

Diam. of Driving or Motor Pulley	Diameter in inches of Machine or Driven Pulley					
	1½	2	2½	3	4	5
1½ inches	1725	1290	1030	860	645	520
2 inches	2300	1725	1380	1150	860	690
2½ inches	2890	2160	1725	1440	1080	860
3 inches	3450	2590	2070	1725	1290	1030
4 inches	4600	3450	2760	2300	1725	1380
5 inches	5750	4310	3450	2870	2160	1725
6½ inches	7460	5600	4490	3740	2800	2240

EXAMPLE—the machine has a 2-in. pulley and should run 3450 or 3500 R.P.M. What size pulley should be used with a 1750 R.P.M. motor? From the above table, follow down the vertical 2-in. column to the speed of 3450, then to the left in column headed "Diameter of Driving or Motor Pulley." The answer is a 4-inch diameter pulley is required.

Hollow-Head Setscrews, Wrenches

F Hollow-Head Setscrews. Take the place of ordinary setscrews. Can be screwed down flush with the surface. Made of tough alloy steel. Shipping weight each 2 ounces.

9 A 2809—Please state diameter and length.

Diameter	Length	Threads to in.	Each
¼ inch	¼ inch	20	5c
¼ inch	½ inch	20	5c
¼ inch	¾ inch	18	5c
¼ inch	1 inch	18	5c
¼ inch	1½ inch	18	5c
¼ inch	2 inch	18	5c

G Wrenches for Hollow Head Setscrews. For above setscrews. Made of hardened and tempered tool steel. Shipping weight each 1 oz.

9 A 2813—Individual sizes. Please be sure to state size wanted.

For ¼-inch screw	9c
For ½-inch screw	9c
For ¾-inch screw	9c
For 1-inch screw	9c
For 1½-inch screw	9c
For 2-inch screw	9c

Shop at Sears and save! Buy the tools you need on Sears convenient Easy Terms... See inside front cover for details.

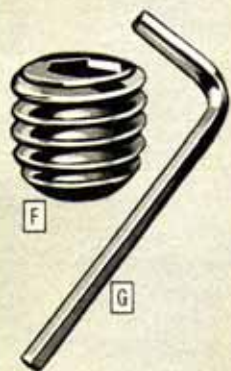

CRAFTSMAN Pulley Remover



Gives a snug and evenly distributed non-slip grip.

H Professional quality. An excellent sheave and pulley remover for removing small V-drive pulleys when frozen fast on electric motors or other power tool shafts and for removing single or multiple drive sheaves.

Fits single or multiple groove pulleys, gears, bearings, etc. Eliminates the need for pulling on outer flange. So simple and easy to operate. Just clamp down in V-groove of sheave or pulley... the pulling strain is evenly distributed around a great part of the circumference. Gives a positive non-slip grip. Has capacity of 1¼ to 4½ inches. Strong steel construction.

One of the handiest tools for the home workshop or for the man who does set-up and mechanical repair work. The perfect tool for solving many service and maintenance problems. Shipping weight 4 lbs. 9 A 4696—Pulley Remover... \$2.70

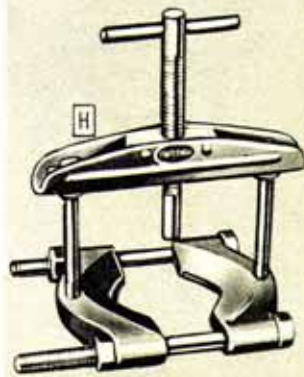

"EASI-BILD" full size Patterns

Just 3 simple steps . . . save money, time and effort . . .



TRACE

Place pattern on wood and trace with pencil



CUT OUT

Saw along traced lines with power or handsaw



ASSEMBLE

Put together according to easy-to-follow directions

NOW YOU can easily make your own household equipment, toys for the children, lawn or porch furniture, and gifts for your friends . . . with "Easi-Bild" full size Patterns. Build your own home, garage, poultry house and many other necessary out-buildings by using "Easi-Bild" Patterns.

Here's the ideal way to save money and have fun doing it. You'll have a great time making any of these things. Anyone who can drive a nail can build them. It's that simple! "Easi-Bild" Full Size Patterns take all the mathematical mystery out of building furniture, toys, etc. It's the dress pattern idea applied to the flat surface of lumber.

Just three simple steps as described above . . . trace, saw and assemble. No hard-to-read blueprints . . . no puzzling scale drawings . . . but, actual full-size patterns. Every pattern contains a list of needed materials, recommended kind of wood, easy-to-follow, step-by-step directions and assembly illustrations . . . even shows you where to use screws, nails, bolts, etc.

The many things YOU can build with these patterns are shown on these pages, set up. Look them over carefully now and decide the patterns you want. Lumber and materials not included. Price and pattern number listed below each pattern. Postpaid. (Shipping weight 6 ounces.)

9 A 2990—"Easi-Bild" Full Size Patterns. State pattern number wanted.

BIRD HOUSES



No. 111 Wren House . . .15c



No. 11 Wren House . . .20c



No. 69 Martin House . . .50c



No. 9 Bird Feeder . . .20c



No. 110 Bluebird House . . .20c



No. 10 Bird House . . .20c

LAWN AND PORCH FURNITURE



No. 56 Foldaway Chair . . .25c



No. 32 Lawn Chair . . .25c



No. 55 Foldaway Settee . . .35c



No. 78 Garden Chaise . . .35c



No. 75 Terrace Table . . .35c



No. 57 Peasant Bench . . .25c



No. 39 Lawn Settee . . .35c



No. 94 California Sun Set . . \$1.00



No. 76 Terrace Chair . . .25c



No. 22 Picnic Table . . .25c

BUILDINGS



No. 910 2 Bedroom House . . \$5.00



No. 100 Child's Playhouse . . 60c



No. 14 Poultry House . . 60c



No. 101 Garage . . .50c



No. 28 Dog House . . .35c



No. 13 Hog House . . .50c



No. 51 Tool and Garden House . . 50c



No. 91 Country Cottage . . \$2.00

EVERY HOME NEEDS



No. 81 Lawn Ornaments . . .25c



No. 15 Handy Workbench . . 25c



No. 73 Outdoor Fireplace . . 25c



No. 19 Window Box . . .25c

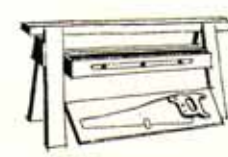

No. 44 Sawhorse Tool Chest . . 35c



No. 71 Tool Chest . . .25c



No. 12 Garden Hotbed . . .25c



No. 85 Utility Boat . . \$1.00

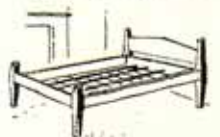

No. 68 Single or Double Bed . . 25c

GIFTS AND TOYS



No. 54 Hobby Horse..20c



No. 53 Pony Ride Rocker..35c



No. 47 Wheel Toy..25c



No. 60 Derrick-Ship..25c



No. 58 Tommy Gun..20c



No. 83 Animals..25c



No. 48 Complete Circus..25c



No. 64 Colonial Cradle..25c



No. 49 Pipe Rack..25c



No. 62 Machine Gun..25c



No. 79 Animals..25c



No. 65 Toy Chest..25c



No. 59 Doll Carriage..35c



No. 40 Express Wagon..35c



No. 46 Plant Holder..25c



No. 33 Doll House..50c



No. 61 Doll Carriage..25c



No. 67 Ferry Boat..25c



No. 50 Airplane Group..25c



No. 70 Cargo Glider..25c



No. 72 Amphibious Freighter..25c

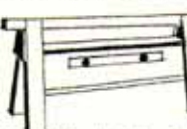

No. 45 Shoeshine Box..25c

CHILDREN'S EQUIPMENT



No. 117 Playtable..25c



No. 20 Sandbox..25c



No. 34 Clotheshree..25c



No. 77 Boat Sandbox..35c



No. 63 Child's Slide..50c



No. 66 Wheelbarrow..25c

INTERIOR

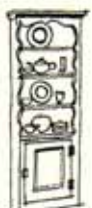

No. 38 Corner Cabinet..50c

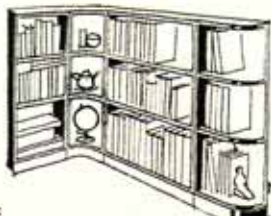

No. 42 Modern Bookcase..50c



No. 7 Flower Pot Holder..15c



No. 21 Bookshelf..15c



No. 30 Window Valance..25c



No. 17 Peasant Table..25c



No. 52 Coffee Table..25c



No. 27 Window Valance..25c

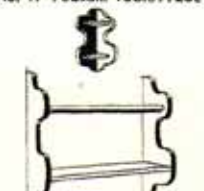

No. 35 Whatnot Shelf..20c



No. 37 Storage Chest..25c



No. 31 Whatnot Shelf..20c



No. 26 Wall Table..25c



No. 25 Magazine Rack..25c

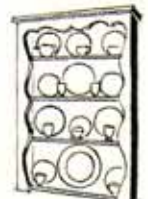

No. 36 Dutch Wall Cabinet..25c



No. 23 Fireside Bench..25c

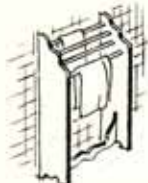

No. 29 Towel Rack..20c



No. 18 Bookcase..25c



No. 24 Wall Shelf..25c

KITCHEN EQUIPMENT



No. 5 Kitchen Shelf..25c

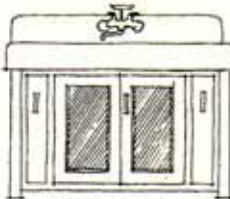

No. 41 Undersink Enclosure..50c



No. 8 Knife Rack..25c



No. 1 Window Valance..25c

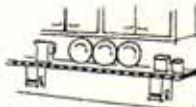

No. 4 Narrow Shelf..25c



No. 80 Service counter..60c



No. 3 Kitchen Unit..50c

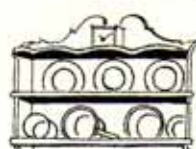

No. 6 All Purpose Shelf..25c



No. 2 Peasant Shelf..25c

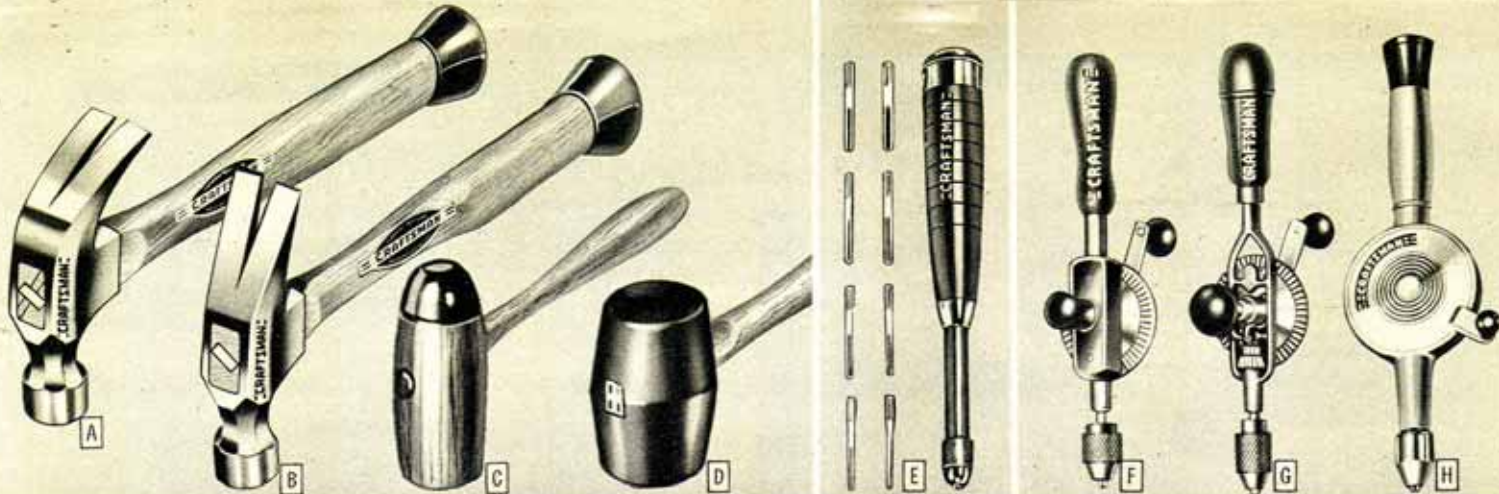

Quality Hand Tools make work easier, faster

CRAFTSMAN Hammers and Mallets

CRAFTSMAN Hammers. Mirror polished heads, drop forged from "Super-Tuff" steel. Claws accurately spaced. Faces beveled to resist chipping. White hickory handles, double steel wedged in tapered eye. Flared rubber tips on handles. **\$235**

- A** 9 A 3814—Curved Claw Carpenters' Hammer. State size wanted. Size 2. 13-ounce head. Shipping weight 1 pound 12 ounces. \$2.35
Size 1½. 16-ounce head. Shipping weight 2 pounds 2 ounces. 2.35
- B** 9 A 3816—Straight Claw (Rip) Hammer. Same quality as above. Size 1½. 16-oz. head. Shipping weight 2 lbs. 2 oz. **\$2.35**
- 9 A 3809—Straight Claw Tradesman's Hammer.** Same quality as above. Size 1. 20-ounce head. Shipping weight 2 lbs. 6 oz. **\$2.45**
- C** CRAFTSMAN Wood Mallet. Seasoned hickory head; size 4; 2½x5½ in. 9 A 3807—8-in. hardwood handle. Shpg. wt. 1 lb. 5 oz. **55c**
- D** CRAFTSMAN Rubber Mallets. Rubber composition head. 10-in. hardwood handle. 9 A 4579—12-ounce head. Shpg. wt. 1 lb. **\$1.25**
18-ounce head. Shpg. wt. 1 lb. 6 oz. **1.45**

Push Drill

E CRAFTSMAN new streamlined design. Precision machined bronze spirals give smooth action. 4-jaw chuck of hardened steel holds drill points firmly. Heavy chrome plated finish. Blue enameled handle is grooved to prevent slipping. Complete with eight drill points, sizes ¼ to 1¼ in., in magazine type handle. Over-all length 9 in. **\$255**

9 A 4216—Shipping weight 1 pound. **\$2.55**

CRAFTSMAN Hand Drills

F Streamlined die-cast frame. Double pinion gear. Machine cut pinion and gear. 3-jaw chuck for round shank drill up to ¼ in. Hardwood handle, mahogany finished. Over-all length 12 in. **\$255**

9 A 4234—Shpg. wt. 2 lbs. 10 oz. **\$2.55**

G Matched machine cut gears. 3-jaw chuck for round shank drills up to ¼ in. Screw-cap hollow hardwood handle for storing drills. Over-all length 12½ inches. **\$2.95**

9 A 4234—Shpg. wt. 2 lbs. 10 oz. **\$2.95**

H Aluminum die-cast frame. Driving gear cast as integral part of turning section. Hollow handle for storing drills. New type Jacobs 3-jaw chuck. Jaws held together with Neoprene. Takes round shank drills up to ¼ in. **\$3.65**

9 A 4242—Shpg. wt. 1 lb. 12 oz. **\$3.65**

9 A 4230—Set of 8 Drills. Fit all hand drills. Sizes ¼ to 1¼ in. by 64ths. Shpg. wt. 4 oz. **45c**

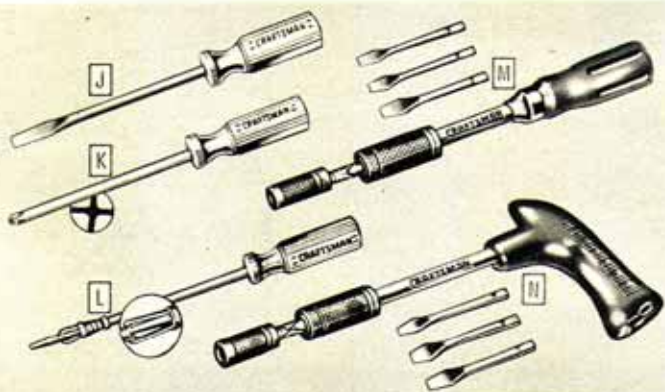

CRAFTSMAN Screwdrivers

J Heavy duty Screwdrivers. "Super-Tuff" steel blades. Amber color plastic handles. Square stock blades. 9 A 4148—State size wanted.

Blade, in.	Shpg. wt.	Each
4x¾	5 oz.	65c
4½x¾	4 oz.	59c
6x¾	6 oz.	85c
8x¾	12 oz.	98c
9x¾	10 oz.	75c
12x¾	10 oz.	98c
12x¾	16 oz.	\$1.25

K Phillips-type Screwdrivers. "Super-Tuff" steel blades; amber color plastic handles. 9 A 4129—State size wanted.

Size	Blade	Shpg. wt.	Each
1.	3-in.	4 oz.	65c
2.	4-in.	5 oz.	79c
3.	6-in.	6 oz.	98c

L Screwholding Screwdrivers. Spring steel clips hold screw to "Super-Tuff" steel blade. Shockproof, amber-colored plastic handles. 9 A 4112—State size wanted.

Blade, in.	Shpg. wt.	Each
2½x¾	4 oz.	49c
4x¾	5 oz.	55c
5x¾	6 oz.	75c
7x¾	8 oz.	85c

Automatic Screwdrivers and Accessories. Professional quality; for heavy duty use. Polished steel frames. Precision machined, hardened "Super-Tuff" steel spirals give powerful action. Drive or draw screws simply by pushing on handle. Left or right hand ratchet or can be set rigid. Comes complete with three bits (small, medium and large size).

M 9 A 4138—Standard size. Straight hardwood handle. Length extended with bit 18¾ inches. Shipping weight 1 lb. 8 oz. **\$3.79**

9 A 4134—Large size. Straight hardwood handle. Length extended with bit 25 in. Shipping weight 1 pound 12 ounces. **\$4.75**

N 9 A 4140—Standard size. Pistol-grip plastic handle. Gives more leverage than straight-type handle. Handle of Tenite plastic; virtually unbreakable in ordinary use. Bits may be stored in handle. Length extended with bit is 19 inches. Shpg. wt. 1 lb. 8 oz. **\$4.50**

9 A 4143—Chuck and 8 Drills. (Not shown.) Converts 9A4138 and 9A4140 screwdrivers (above) into drills. Not suitable for use with 9A4134. Eight drills, ¼ and 1¼ inch. Shpg. wt. 3 oz. **98c**

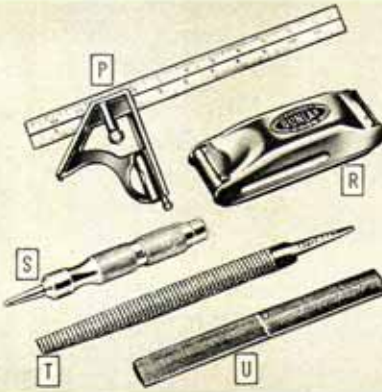

Combination Square

P CRAFTSMAN. Steel blade graduated in 8ths and 16ths of an inch. Blade slotted so handle can be moved to any point on blade. Semi-steel handle has level and scriber. Shpg. wt. 1 lb. State size. 9 A 3954—9-in. blade. **\$1.25**
12-in. blade. **1.39**

DUNLAP Sanding Block

R 6-in. bright steel block frame with 30x1½-in. roll of medium grit sanding cloth, stretched over felt cushion. 9 A 3681—Shpg. wt. 12 oz. **79c**

Sanding Cloth Refill for above sanding block. 30x1½-in. rolls, medium grit. 9 A 3688—Shpg. wt. 3 oz. 3 rolls for 25c

Self-centering Punch

S CRAFTSMAN. Steel; knurled for sure grip. Nickel plated. Length 3 in. 9 A 4282—Shpg. wt. 4 oz. Each **29c**

CRAFTSMAN Rasps

T Shoe Rasps. Half round. Half surface rasp cut, half file cut. **State size.**

Length	Shpg. wt.	Each
8-inch	10-inch	69c
10-inch	14 oz.	85c
12-inch	1 lb. 4 oz.	\$1.15

U Half round Rasps. Tapered sides. 9 A 6776—State length wanted.

Length	Shpg. wt.	Each
8-inch	10 oz.	69c
10-inch	14 oz.	85c
12-inch	1 lb. 4 oz.	\$1.15



Wood Dowel Assortment

V For model building, furniture repairing, etc. 14 sizes, ¼ to ¾ in. diameter. 16 in. long. Clear-grain hardwood. 9 A 2909—Shpg. wt. 14 oz. Pkg. of 14. **39c**

CRAFTSMAN Sharpening Stone

W Keep your tools sharp. Vitrified silicon carbide. Fine grit one side; coarse grit other side. Please state size. 9 A 6440—Size 5x2x¾ in. Shpg. wt. 12 oz. **\$1.10**
Size 6x2x1 in. Shpg. wt. 1 lb. **\$1.45**
Size 7x2x1 in. Shpg. wt. 1 lb. 8 oz. **1.65**

Medium Fine Slip Stone

X DUNLAP. Round edge. Medium fin. For gouges and other round shaped tools. Size 4x1¾ in.; taper from ½ to ¼ in. 9 A 6454—Shpg. wt. 12 oz. **79c**

CRAFTSMAN Lubricating Oil

Y For electric motor and general shop use. Will not gum or become sticky. 9 A 6547—½-pint. Shpg. wt. 8 oz. **19c**

Stop-Rust . . . safe to handle

Z DUNLAP. Protects tools from rust. Can be brushed, sprayed or dipped on. Non-inflammatory. State number of cans wanted. 9 A 2927—8-oz. can. Shpg. wt. 9 oz. **29c**
Four 8-oz. cans. Shpg. wt. 2 lbs. 4 oz. **98c**

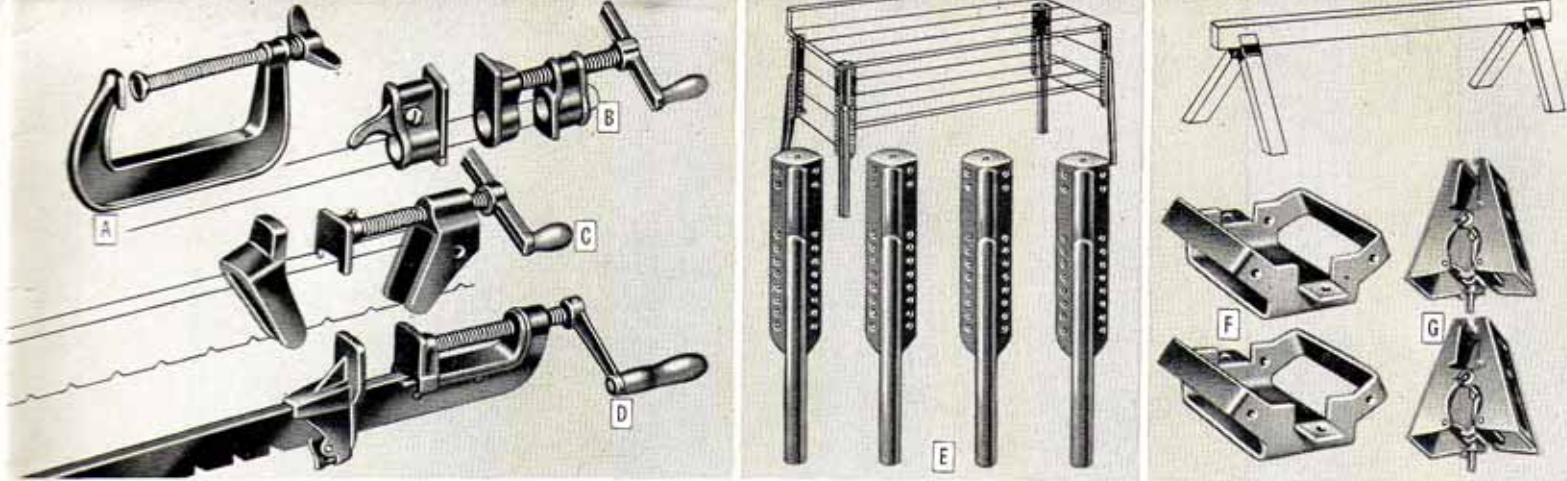

Quality Accessories for your power equipment

Heavy Duty Clamps

A Iron C Clamps. Strong clamps with Acme-threaded screw. Self-adjusting swivel head.

9 A 6667—Please state size

Opens to	Shpg. wt.	Each
3 inches	1 lb. 8 oz.	\$0.79
4 inches	2 lbs. 2 oz.	1.09
5 inches	2 lbs. 8 oz.	1.19
6 inches	3 lbs. 2 oz.	1.39
8 inches	4 lbs. 8 oz.	1.98

C Gluing Clamp. Wood bar type. For any length wood bar, 1 3/4 x 2 3/4 inches. Malleable iron. Sliding jaw has 1 3/4 x 1 3/4-inch face. Crank adjustment. Shpg. wt. 4 lbs. 8 oz.

9 A 6673—\$2.25

B Gluing Clamp. Adjustable pipe style. Use with any 3/4-inch threaded pipe. Malleable iron. Convenient crank adjustment. Sliding jaw has 1 3/4 x 1 3/4-inch face; handy lever lock. With cap for end of pipe; without pipe. Shpg. wt. 3 lbs. 14 oz.

9 A 6674—\$2.59

D Cabinet Makers' Steel Clamp. T-bar type. Bar is 1 1/2 x 3/4 x 3/8 in. Sliding jaw has 1 1/2-inch face; locks in notches.

99 A 06676—Please state size

Opens to	Shpg. wt.	Each
3 feet	8 lbs.	\$4.69
4 feet	9 lbs.	5.25

CRAFTSMAN Bench Leg Set

E Now you can build a strong, rigid work bench, machine table, or lathe bench with CRAFTSMAN steel legs and your own lumber. Each leg is made from one piece of extra heavy cold rolled steel; punched at top for attaching to bench top; punched at bottom for fastening to floor or for attaching casters. Each leg has perforations enabling you to install lower shelf or cross braces at 6 different heights. Side boards may be added if desired.

Set includes 4 steel bench legs with shelf support brackets; lag screws, cadmium-plated bolts, lock washers and nuts for fastening brackets. Instructions. Gray enameled finish. Wood parts not included.

99 A 02732—Height 26 in. Shpg. wt. 17 lbs. \$5.95
99 A 02731—Height 31 in. Shpg. wt. 18 lbs. 5.95

\$595
Set of 4

Sawhorse Brackets

Two types for making your own sawhorses quickly and easily. Lumber not included.

F For use with 2x4's. Made of heavy gauge, rust-resistant plated steel. Electrically welded into one solid unit for strength and rigidity. Wedge shaped.

9 A 2889—Shpg. wt. 3 lbs. Pr. \$1.50

G New type. Needs no nails, screws or bolts. Rust-resistant plated steel.

9 A 2848—For 1x4's. Shipping weight 6 pounds. Pair \$2.80
9 A 2849—For 2x4's. Shipping weight 7 pounds. Pair 3.25

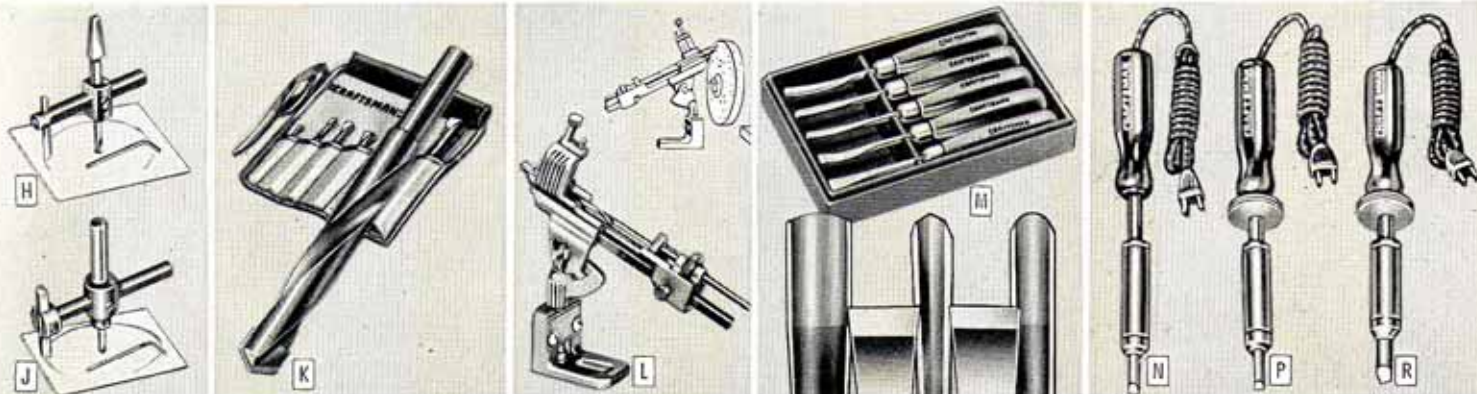

CRAFTSMAN Circle Cutters

H For small jobs. Tapered square shank for standard bit brace. Cuts hole 1 to 5 1/4-inch diameter. Easy adjustment. Removable high speed steel bit.

9 A 3640—Shipping weight 10 oz. \$2.39

J Heavy duty for larger jobs. Has 3/4-inch shank for use in drill presses or electric drills. Easy, quick adjustment. Cut holes 2 to 8-inch diameter, up to 1-inch deep; in sheet steel, aluminum, brass, wood, plastic, fiber, etc. For pipe or ventilator holes; instrument panels on radios, autos, etc. With removable high speed steel bit.

9 A 3641—Shipping weight 10 oz. \$4.65

CRAFTSMAN Masonry Drills

K Made of steel with carbide tips. Accurate sizes. New type, with spiral flutes for faster, cleaner cutting. Drills stone, marble, concrete, etc. Round shank for use with electric or hand and breast drills.

9 A 6731—Set of 6 CRAFTSMAN carbide-tipped Masonry Drills. One each of each size listed below. Come in neat fabric carrying or storage case. Shipping weight 2 pounds. \$12.50

9 A 6730—State size wanted when ordering.

Size	Shank	Length	Shpg. wt.	Each
3/8 in.	3/8 in.	4 in.	4 oz.	\$1.49
1/2 in.	1/2 in.	4 in.	4 oz.	1.69
5/8 in.	5/8 in.	4 in.	6 oz.	1.79
3/4 in.	3/4 in.	6 in.	8 oz.	2.15
7/8 in.	7/8 in.	6 in.	10 oz.	2.65
1 in.	1 in.	6 in.	12 oz.	3.29

CRAFTSMAN Drill Grinding Attachment

L There has been a tremendous demand for a moderately priced tool of this type! Now you can repoint your drills with factory accuracy right in your own shop. Drill manufacturers always recommend use of drill grinding attachments and advise avoiding hand grinding. Gives more accurate points for sharper, smoother drills.

Precision built with strong, non-rusting die cast aluminum frame. Overall height 7 inches. Designed to give exceptionally accurate adjustments... may be adjusted for all popular drill point angles, including countersinks. It's amazingly easy and simple to operate. Complete easy-to-understand instructions included with each outfit.

Will handle twist drills of the following sizes: 3/8-inch to 3/4-inch fractional; No. 1 to No. 30 number size; A to Z letter size; 3.0 millimeter to 19.0 millimeter metric size.

9 A 6677—Shipping weight 2 pounds 8 ounces. \$5.45

CRAFTSMAN Wood-Carving Tool Set

M A great favorite with professional craftsmen, model makers and hobbyists for carving models, plaques, book ends, jewelry boxes, etc. Also for cutting linoleum, printing blocks, etc. Set includes one 3/4-in. bent gouge, one 3/8-in. bent chisel, one 3/32 in. "U" tool, one 1/8-in. straight chisel, and one 3/32 inch veining tool. Blades are 2 1/2 in. long, and are forged from high quality heat treated steel that takes and holds a razor-keen edge... will withstand repeated sharpenings. The comfortable 3 3/4-inch smooth-finished hardwood handles have sturdy metal ferrules. The 5-piece set comes packed in special cardboard box.

9 A 2899—Set of 5 tools. Shipping weight 13 ounces. \$3.25

CRAFTSMAN Soldering Irons

N 100-watt specialists' soldering iron. Approved by Underwriters' Laboratories, Inc. For electrical and radio workers who do delicate soldering jobs. 2 3/4-oz. replaceable insert-type solid copper tip; 4 1/4 in. long. Heat concentrated at point by Nichrome element wound on Allegheny steel core insulated with mica. Hardwood handle. 6-foot insulated cord with plug. For any 110-120 volt current.

9 A 5381—shpg. wt. 1 lb. 8 oz. Each \$4.25

P 150-watt general purpose soldering iron. Approved by Underwriters' Labs., Inc. 2 3/4-oz. replaceable insert-type solid copper tip; 4 3/4 inches long. Can be filed to any shape. Nichrome element wound on mica insulated Allegheny steel core, concentrates heat almost instantly at point. 3 cooling fins. Hardwood handle. 6-foot insulated cord with plug. For any 110-120 volt current.

9 A 5382—Shpg. wt. 1 lb. 8 oz. Each \$5.19

R 200-watt heavy duty soldering iron. Approved by Underwriters' Laboratories, Inc. 6-ounce inserted solid copper tip; length 4 1/2 in; diameter 3/8 in. Pull out as it wears down. Blunt end for "running" seams. File to any shape. Heat quickly concentrated at point by Nichrome element on mica insulated Allegheny steel core, 3 cooling fins. Hardwood handle. 6-ft. insulated cord with plug. For any 110-120 volt current.

9 A 5383—Shpg. wt. 1 lb. 8 oz. Each \$5.65

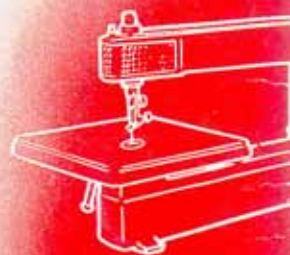
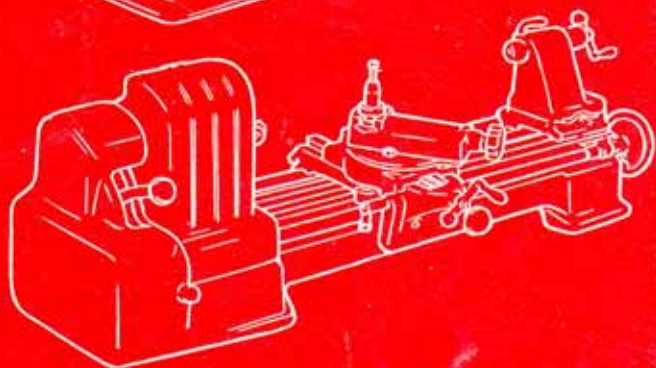
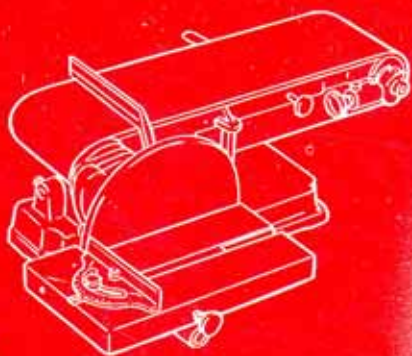

CRAFTSMAN
REG. U.S. PAT. OFF.

DRILL PRESSES

For a complete description
of **CRAFTSMAN** Drill Presses
REG. U.S. PAT. OFF.
and accessories, turn to
pages 18, 19, 20 and 21

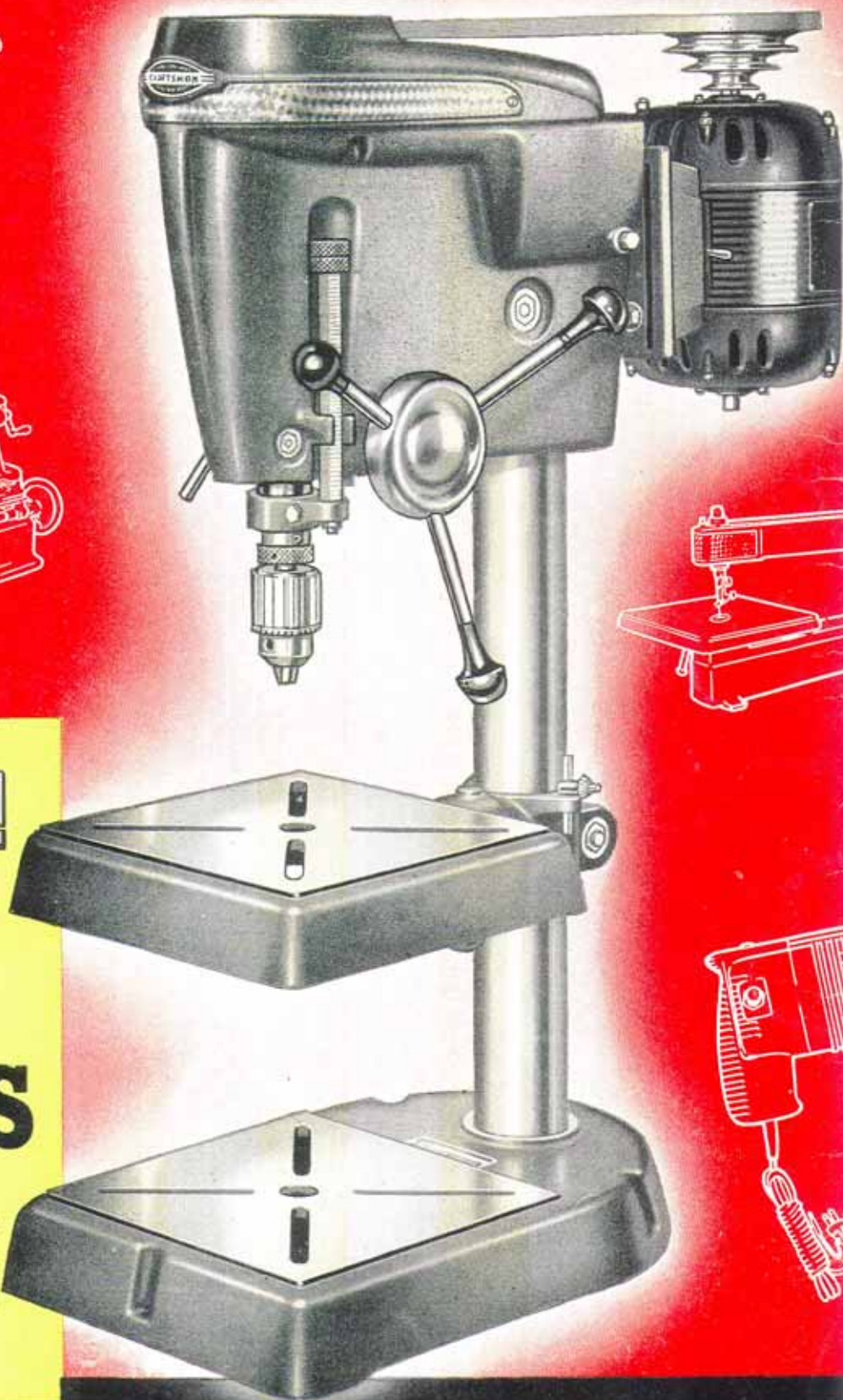

SEARS, ROEBUCK and CO.
Satisfaction Guaranteed or Your Money Back . . .