

FIRST TIME IN **5** YEARS.. A COMPLETE LINE OF

CRAFTSMAN
REG. U. S. PAT. OFF.

POWER TOOLS



SEARS ROEBUCK and CO.

Satisfaction Guaranteed or Your Money Back...

INDEX

	PAGE
Abrasives.....	23
Air Hammer.....	20
Band Saws.....	6
Bench Saws.....	2, 3
Builders' Saw.....	4
Chucks.....	32, 33
Drill Presses.....	28, 29
Drill Press Accessories.....	30, 31
Drill Sets.....	25
Easi-Bild Patterns.....	44, 45
Electric Drills.....	26, 27
Emerson Saws.....	1
Fender Repair Tool.....	39
Flexible Shafts.....	24
Grinders.....	20, 21
Hack Saw, power.....	48
Hand Saw, electric.....	5
Instruction Books.....	7
Jig Saws.....	8, 9
Jointer-Planers.....	12
Lathes: Wood and Accessories.....	18, 19
Metal Turning and Accessories.....	34, 35, 36, 37
Motor Rails.....	42
Polishing Heads.....	20
Polishing Materials.....	22
Rotary Tool and Accessories.....	17
Sanders: Belt and Disc.....	16
Portable Belt.....	14
Portable Disc.....	15
Saw Blades and Accessories.....	10, 11
Thickness Planers.....	13
V-Belts.....	46
Vises.....	43
V-Pulleys.....	47
Welders: Arc and Accessories.....	40, 41
Oxy-acetylene and Accessories.....	38, 39

4 easy ways to Shop at Sears



AT SEARS RETAIL STORES

You get the advantages of retail selling
... competent sales people to serve you
... expert power tool advice ... home
delivery ... courteous personal attention.



AT CATALOG ORDER DESKS

You'll find one in every Sears store or in
Sears catalog order offices. Courteous clerk
will assist you in placing your order. You
save postage and money order fees.



AT HOME BY PHONE

You simply pick out the tools you want
from this catalog. Then phone the Order
Department at Sears nearest retail store.
Sears will send your order C.O.D.



AT HOME BY MAIL

You pick out the tools you want from this
catalog. Fill out an order blank. Mail it to
Sears nearest Mail Order House with your
remittance. That's all there is to it.

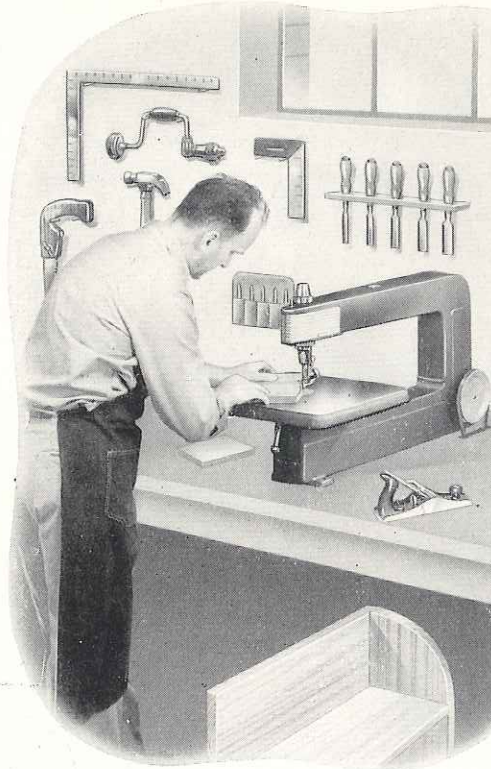

**Top quality costs
less at Sears**

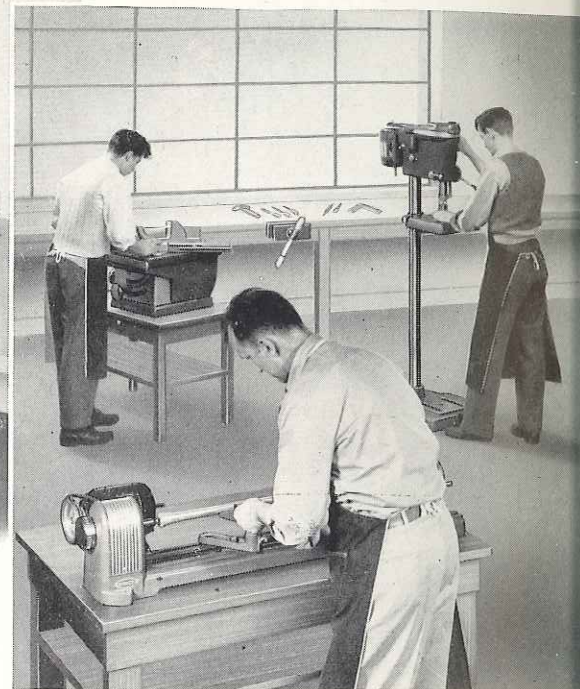

CRAFTSMAN
REG. U. S. PAT. OFF.

Power Tools set the pace and price!

The CRAFTSMAN Power Tools presented in this catalog are the result of years of Sears "know-how" in the power tool field of engineering, manufacturing and distribution. Sears gives you assurance of maximum accuracy and precision. Each tool is soundly engineered by our technical staff of experts plus the engineering staffs of America's foremost manufacturers of power tools.

Sears anticipates your needs

Sears constantly has its finger on the pulse of the field. The demands and needs of power tool users are made known to us through our hundreds of retail stores and our eleven huge mail order houses. New designs, modifications and added features, which you, the user, want, are steadily being incorporated into each CRAFTSMAN Power Tool. Each tool is thoroughly inspected and tested by the manufacturer and our own testing laboratory before we offer it to you. It must be *Right* to have the CRAFTSMAN label. As a result, Sears brings you the most up-to-date, precision power tools possible.

Developments perfected by Sears

Several years ago, Sears presented a radically different drill press with the "Floating Drive" spindle assembly. This was designed and produced to eliminate the objectionable spindle whip and vibration present in conventional drill presses. Next came a back-gear screw cutting lathe, with accuracy, precision and quality never before

thought possible at Sears low price. Next Sears made available, in the moderate price field, the famous tilting arbor bench saw. Following these came the new 3-drum construction portable belt sander, the exclusive new "Walking Beam" drive action jig saw which gives a smooth up and down stroke, the fully enclosed band saw, and many, many others... making Sears CRAFTSMAN Power Tools the leaders and pace makers in the field.

Top quality first at Sears

Besides leading the industry in advancements in power tool engineering, Sears have always insisted on quality at the lowest price possible. Sears modern methods of merchandising eliminate much of the costly selling over-head. The entire cost of production goes into top quality materials and workmanship, not into expensive distribution and other costly sales methods. We pass these savings on to you—the purchasers of CRAFTSMAN Power Tools.

The point is, CRAFTSMAN Power Tools have the dominant position in the field. They set the pace and price. America's craftsmen, both professional and amateur, know they are getting soundly engineered products of superior construction at prices they can afford to pay. And you are protected by a *Guarantee* that has been nationally famous for over Fifty Years.

Be wise, buy and use CRAFTSMAN Power Tools. With men who know and use power tools, it's CRAFTSMAN first and foremost.

Important notice about prices

The low prices in this catalog will be maintained if possible. However, because of the uncertainty of raw material markets we cannot guarantee to maintain the prices shown, and we reserve the right to increase the price of any item if it becomes necessary to do so.

Furthermore, should the Federal Government or any State increase by taxes or otherwise the cost or selling price of any of the merchandise shown in this book, we reserve the right to add such taxes or other increases of cost or selling to the prices shown in this catalog.

NEW! CRAFTSMAN "100" Tilting Arbor Bench Saws

Beauty and strength combined with delicate precision operation

NOW CRAFTSMAN offers you the most important and indispensable wood working power tool in TWO sizes . . . an 8- and 10-inch bench saw. These CRAFTSMAN Tilting Arbor Bench Saws are tough, rugged, powerful saws and are precision built to do accurate, high quality continuous production work.

Work stays level. No more holding lumber at an awkward, uncomfortable angle! The blade and arbor tilt 0 to 45 degrees . . . the table and work always stay level. Saw blade and arbor are rigidly supported in massive cradle and trunnions . . . raise and lower to vary depth of cut . . . lock at any desired angle. No twisted belt . . . motor tilts with the blade.

Exceptionally large table. Heavy cast semi-steel; precision ground. Has removable insert for dadoing or sanding. Quick-acting, self-squaring rip fence locks at both ends with one handle; can be used on either side of blade. Vernier adjustment. Grooved on both sides for right or left hand miter cuts. Cuts all angles including compound miters. Accurate miter gauge has stop rods for repetitive cuts.

Automatic leveling guard. Tilts with the blade. Has transparent plastic insert . . . protects the operator . . . permits him to see work. Guard equipped with non-kick back pawls and splitter blade. Has built-in sawdust chute and guard.

SPECIFICATIONS for 8-inch model:

- Depth of cut, maximum 2 $\frac{3}{8}$ inches
- Blade, combination type—size 8 inch diameter bore $\frac{5}{8}$ inch
- Table size 18x20 inches
- Table size, with front extension (not included) . . 18x27 inches
- Dado capacity:
 - width 1 $\frac{1}{16}$ inch
 - depth, with 6-inch dado saw 1 $\frac{3}{8}$ inches
- Bearings Two-ball
- Arbor speed recommended 4140 R.P.M.
- Motor recommended, minimum $\frac{1}{2}$ H.P. 3450 R.P.M.
- Machine pulley (included) 2 $\frac{1}{2}$ inches
- Motor pulley (included) 3 inches
- Mounting dimensions 11 $\frac{1}{4}$ x13 $\frac{7}{16}$ inches
- Over-all dimensions: Height 17 $\frac{1}{4}$ inches; width 20 $\frac{1}{2}$ inches; length 26 $\frac{3}{8}$ inches.

- A** 99 TM 2240—8-inch model without motor. Shipping weight 140 pounds. **\$87.50**
- 99 TM 2249—8-inch model with $\frac{3}{4}$ H.P. capacitor 3450 R.P.M. 110-120 volt 60 cycle A.C. motor. Shipping weight 188 pounds. **\$131.00**

SPECIFICATIONS for 10-inch model:

- Depth of cut, maximum 3 $\frac{3}{8}$ inches
- Blade, combination type—size 10-inch diameter bore $\frac{5}{8}$ inch
- Table size 20x27 inches
- Dado capacity:
 - width 1 $\frac{1}{16}$ inch
 - depth, with 6-inch dado saw 1 $\frac{3}{8}$ inches
- Bearings Two-ball
- Arbor speed recommended 3450 R.P.M.
- Motor recommended, minimum $\frac{3}{4}$ H.P. 3450 R.P.M.
- Machine pulley (included) 2 $\frac{1}{2}$ inches
- Motor pulley (included) 2 $\frac{1}{2}$ inches
- Mounting dimensions 11 $\frac{1}{4}$ x13 $\frac{7}{16}$ inches
- Over-all dimensions: Height 18 $\frac{1}{2}$ inches; width 21 $\frac{1}{2}$ inches; length 33 $\frac{3}{8}$ inches.

- B** 99 TM 2241—10-inch model without motor. Shipping weight 160 pounds. **\$99.50**
- 99 TM 2250—10-inch model with $\frac{3}{4}$ H.P. capacitor 3450 R.P.M. 110-120 volt 60-cycle A.C. motor. Shipping weight 208 pounds. **\$142.50**

C Table and Rip Fence Extension. For above 8-inch saw only. Increases table size to 18x27 inches. 99 T 02245—Shipping weight 18 lbs **\$9.95**

D Table Extension Bracket. For side extension on above 8- and 10-inch bench saws. Comes packed one bracket per package. 9 T 2253—Shipping weight 1 lb. 5 oz **95c**

E Dado Insert. For 8- or 10-inch bench saws above. 9 T 2212—Shipping weight 12 oz. **98c**

F Sanding Insert. For above 8- or 10-inch saws. 9 T 2283—Shipping weight 12 oz. **98c**

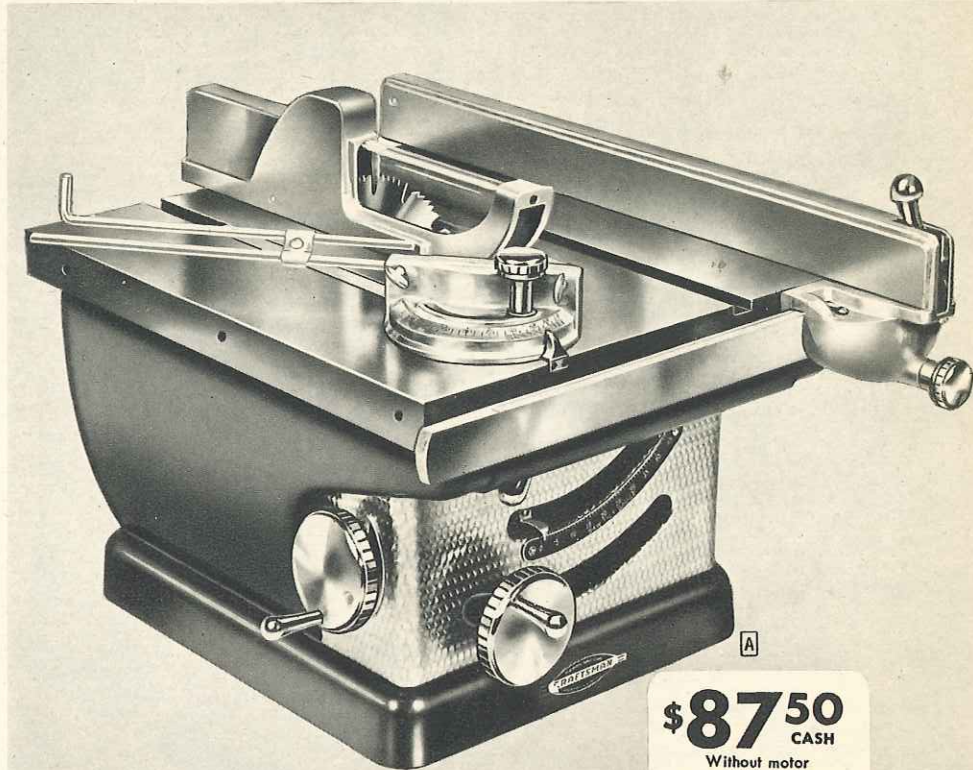

\$87.50 CASH
Without motor
\$900 DOWN ON TERMS

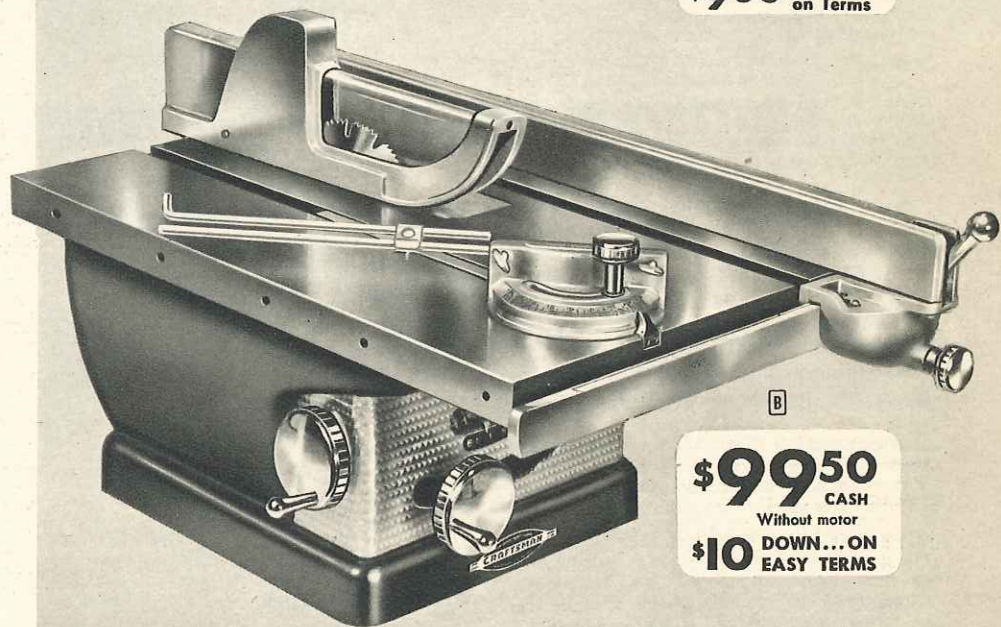

\$99.50 CASH
Without motor
\$10 DOWN... ON EASY TERMS

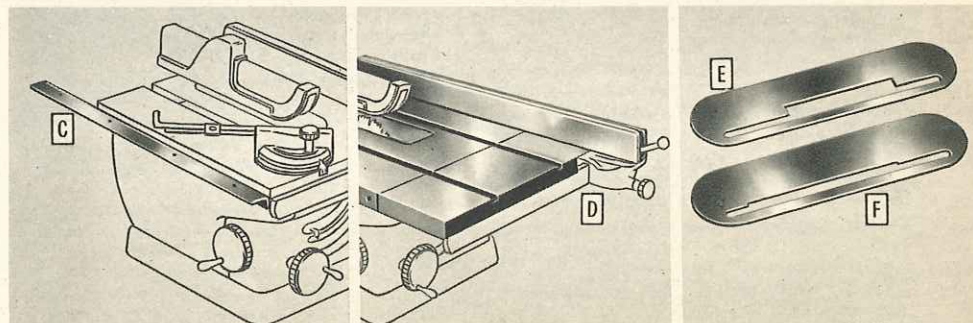

CRAFTSMAN
REG. U.S. PAT. OFF.

THE RIGHT WAY
TO SAY
**HARDWARE
AND TOOLS**

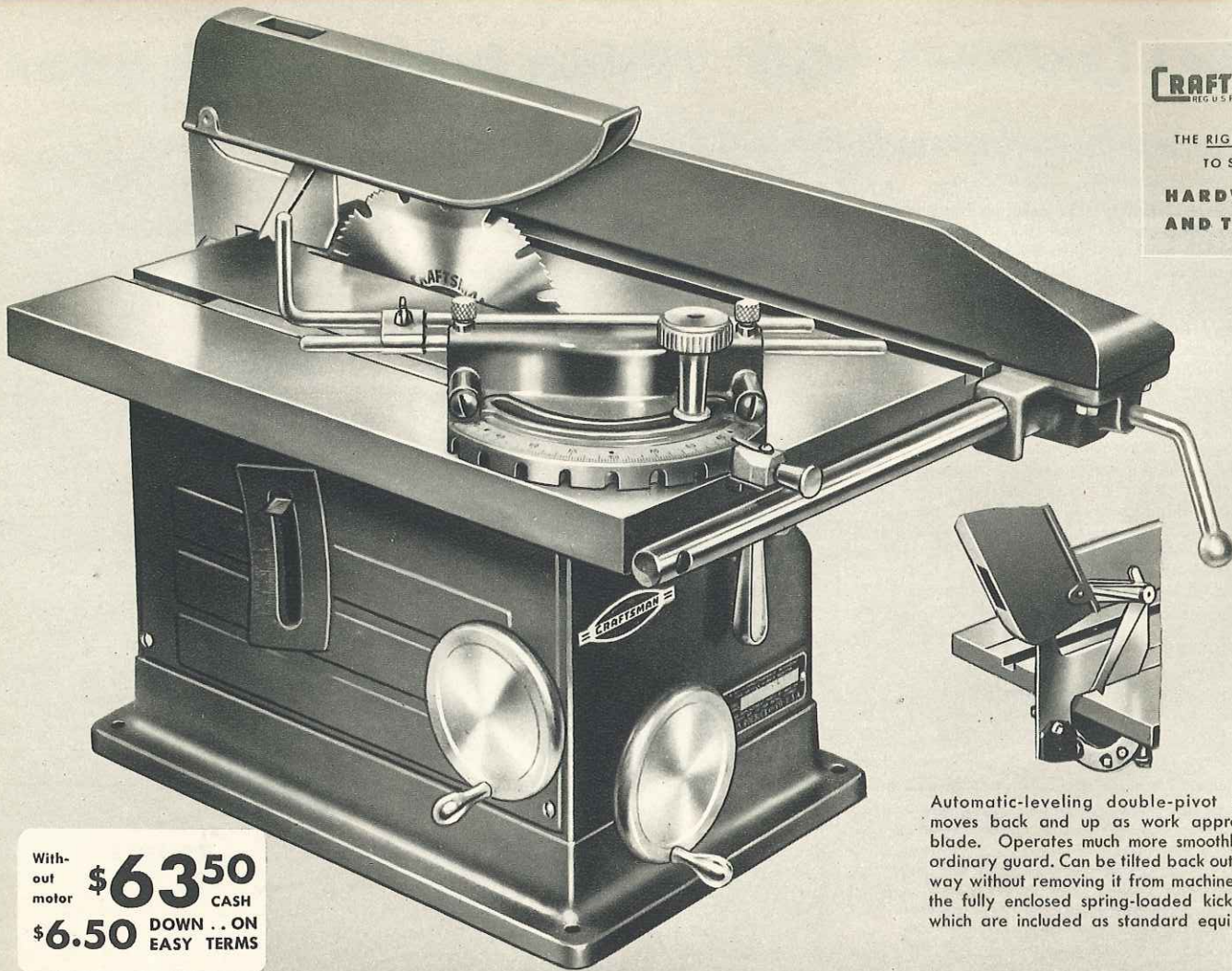

Automatic-leveling double-pivot guard moves back and up as work approaches blade. Operates much more smoothly than ordinary guard. Can be tilted back out of the way without removing it from machine. Note the fully enclosed spring-loaded kick-backs which are included as standard equipment.

Without motor **\$63.50** CASH
\$6.50 DOWN . . ON EASY TERMS

CRAFTSMAN "80" 8-inch Tilting Table Saw

Has maximum depth of cut of 2½ inches

Woodworkers . . modelmakers . . patternmakers . . building maintenance men . . home craftsmen! Here is the ideal saw for you men who want a sturdy, accurate tool. The CRAFTSMAN 8-inch tilting table bench saw meets the most rigid demands of amateur and professional craftsmen and industrial shops. It's big, rugged . . . a real brute of a tool. Heavy duty, too! It has the famous CRAFTSMAN quality in every detail. And it's priced so you can afford it. Check the following specifications and features for yourself. You'll agree it's an outstanding tilting table bench saw! Just the one you need for your work and your workshop.

Large capacity. Maximum depth of cut is 2½ inches. Depth of dado cut is 1½ inches and width of dado cut is ½-inch maximum. With this saw, you can miter up to 2-inch lumber.

Ample working surface. The table, a full 15¼x18x¾ inches, is sturdily made of cast semi-steel, smoothly ground and polished. It's large enough for you to handle good sized work. Table is rib braced for added strength and is grooved on both sides of blade for either left or right hand miter cuts. Removable insert for dadoing.

Table tilts to any angle up to 45 degrees on oversize double trunnions. Table tilting easily and quickly controlled by convenient handwheel and self-locking screw. Table may be manually locked if desired. The accurate gauge shows angle of tilt.

Precision high speed ball bearing operation. Arbor spins freely on two sets of ball bearings. Bearings are accurately ground and finished, packed in grease and sealed against dirt and grit. This assures you of smooth, long-life operation.

8-inch combination blade can be used as rip, crosscut or miter blade. Expertly made of heat treated "Super-Tuff" steel, hand hammered for accuracy. Blade can be raised and lowered by convenient hand wheel control.

SPECIFICATIONS:

- Depth of cut, maximum 2½ inches
- Table size 15¼x18¾ inches
- Table with extensions (not included) 26¾x23¾ inches
- Dado capacity, maximum, with 6-in. head.:
Width . . . ½ inch Depth . . . 1½ inches
- Blade Diameter 8 inches
Type Combination
Bore ½ inch
- Bearings 2 ball
- Recommended arbor speed 4500 R.P.M.
- Motor recommended ½ H.P. 3450 R.P.M.
- Machine pulley (included) 2 inch
- Motor pulley (not included) 2½ inch
- Mounting dimensions 9¾x14½ inches
- Over-all dimensions: Height 14½ inches; width 19 inches; length 24¾ inches.

With blade, machine pulley, rip fence, splitter; automatic-leveling double-pivot guard with enclosed spring loaded kick-back pawls, indexing miter gauge and stop rods for repetitive cut-offs.
99 TM 2199—CRAFTSMAN 8-inch Bench Saw without motor. Shipping weight 97 lbs. . . . \$63.50
99 TM 2197—CRAFTSMAN 8-inch Bench Saw with ½-H.P. ball bearing capacitor motor for 110-120-volt 60-cycle A.C. Shpg. wt. 133 lbs. . . . \$93.00

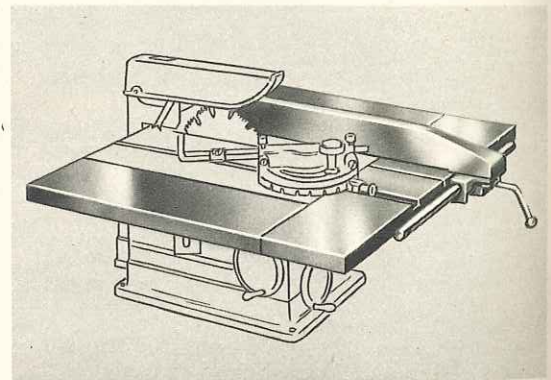

Table Extension Set for above saw

Increases the working surface of your 99 TM 2199 bench saw table to 26¾x23¾ inches. Gives an additional 5⅞-inch table surface ahead of saw blade. Fits 99 TM 2199 saw perfectly . . . gives you a solid working surface that permits you to handle larger work than you could without this extension set. Set includes: two cast semi-steel front extensions, smooth ground and polished; two stamped steel side extensions; one rear support bar and all the necessary bolts and fittings needed to install extensions.

99 TM 02232—Shipping weight 31 lbs. \$15.95

Replacement Blades

Eight-inch combination type circular saw blades for use on 99 TM 2199 saw are listed and shown on page 10 of this 1948 CRAFTSMAN Power Tool Catalog. Buy yours today!

Easy Terms

Short of cash? Buy your power tools on Sears Easy Terms. Only 10% down; balance payable monthly. See inside back cover for details.

CRAFTSMAN "80"
REG. U. S. PAT. OFF.

Tilting Table Saw



With-
out
motor **\$38.00** CASH
\$4 DOWN . . ON SEARS
EASY PAYMENTS

Rugged heavy duty type . . . our finest 7-inch tilting table saw. Massive cast semi-steel construction throughout.

Bigger, heavier table. 16 3/16 x 12 1/4-inch table tilts 0 to 45 degrees . . . locks in angle position. Grooved on both sides of blade for mitering. Has removable insert for dadoing. Self-aligning rip fence may be used on either side of blade.

Depth of cut adjustable 0 to 2 1/4 inches. 7-inch combination blade with 1/2-inch bore may be raised and lowered by ball crank mechanism. Convenient hand wheel controls depth of cut. Streamlined, metal guard over blade.

Massive cast iron base completely encloses mechanism. Self-lubricating oilite bronze bearings; oil filters through bronze.

Comes with guard, splitter, miter gauge and blade.

SPECIFICATIONS:

- Depth of cut, maximum 2 1/4 inches
- Blade 7-inch combination type with 1/2-inch bore
- Table size 12 1/4 x 16 3/16 inches
- Table size with extensions (not included) . . . 23 3/8 x 16 3/16 in.
- Dado capacity, max., with 6 in. head 1 1/2 inch
- Bearings Two self-lubricating oilite bronze
- Recommended arbor speed 4500 R.P.M.
- Motor recommended, minimum 1/2 H.P. 1750 R.P.M.
- Machine pulley (included) 2 inch
- Motor pulley (not included) 5 inch
- Mounting dimensions 11 3/4 x 6 3/8 inches
- Over-all dimensions: Height 14 inches; width 12 1/4 inches; length 20 3/8 inches

99 T 02342—Without motor. Shpg. wt. 60 lbs. **\$38.00**

99 TM 2378—With 1/2 H.P. 1750 R.P.M. split phase ball bearing motor for 110-120 volt A.C. Shpg. wt. 90 lbs. **\$56.50**

DUNLAP 7-inch

REG. U. S. PAT. OFF.

Tilting Table Saw

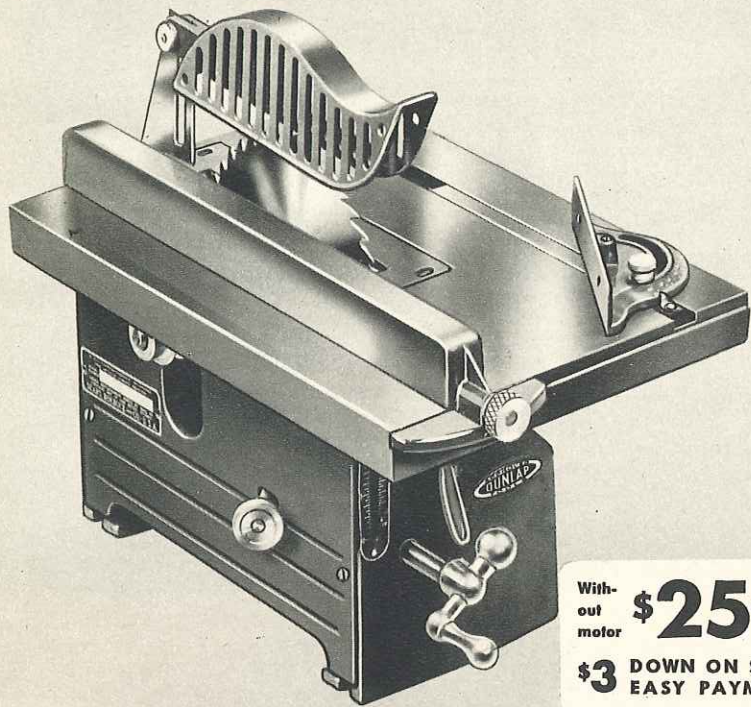

With-
out
motor **\$25.50** CASH
\$3 DOWN ON SEARS
EASY PAYMENTS

The ideal saw for home or small workshop use. It does a fine job of cross-cutting, ripping, mitering and grooving.

Maximum depth of cut 2 1/4 inches. Has 7-inch combination blade. Ball crank mechanism raises and lowers blade.

14 1/2 x 10 1/8-inch table tilts 0 to 45 degrees. Table smooth ground; made of cast semi-steel. Removable insert for dadoing. Self-aligning rip fence locks in position. Adjustable guard.

Complete with guard, splitter miter gauge and rip blade.

SPECIFICATIONS:

- Depth of cut, maximum 2 1/4 inches
- Blade 7 inch rip blade with 1/2-inch bore
- Table size 14 1/2 x 10 1/8 inches
- Extensions Not available
- Dado capacity, max., with 6 in. head 3/8 inch
- Bearings Two self-lubricating oilite bronze
- Recommended arbor speed 4500 R.P.M.
- Motor recommended, minimum 1/2 H.P. 1750 R.P.M.
- Machine pulley (included) 1 1/2 inch
- Motor pulley (not included) 4 inch
- Mounting dimensions 9 5/8 x 4 3/8 inches
- Over-all dimensions . . . Height 11 1/2 inches; width 10 1/8 inches; length 17 3/8 inches.

99 T 02169—Without motor. Shpg. wt. 35 lbs. **\$25.50**

99 T 02165—With 1/2 H.P. 1750 R.P.M. split phase ball bearing motor for 110-120 volt A.C. Shpg. wt. 66 lbs. **\$44.00**

Table Extension

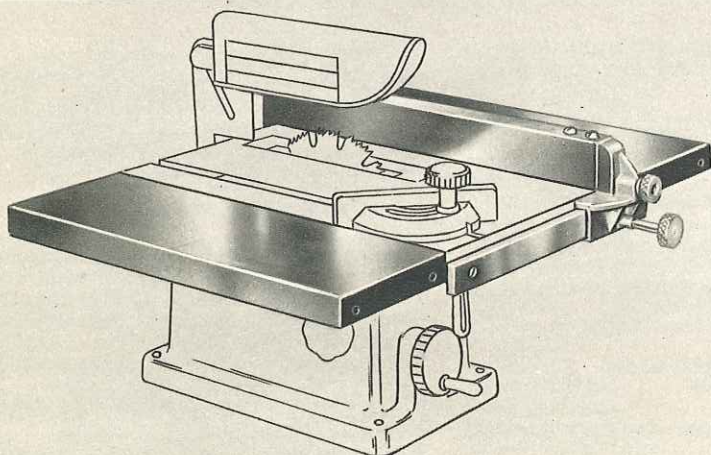

\$4.89 Designed for use with CRAFTSMAN 7-inch heavy duty tilting table saw, 99 T 02342, above. Fits perfectly. Provides much bigger working surface so you can handle larger work with greater ease. Total working surface of saw table increased from 12 1/4 x 16 3/16 inches to 23 3/8 x 16 3/16 inches. Set consists of two smooth steel side extensions, each 5 9/16 x 16 3/16 inches in size, plus all necessary support bars and fittings for attaching extensions to saw. One extension is mounted on each side of blade. Rip fence may be used over the entire length of the extensions. Extensions easily installed.

9 T 2174—Shipping weight 7 lbs. 8 oz. Set **\$4.89**

Motor Pulleys and V-belts

Not supplied with any of saws on these two pages. Order separately. For V-belts, see page 46; for pulleys, page 47.

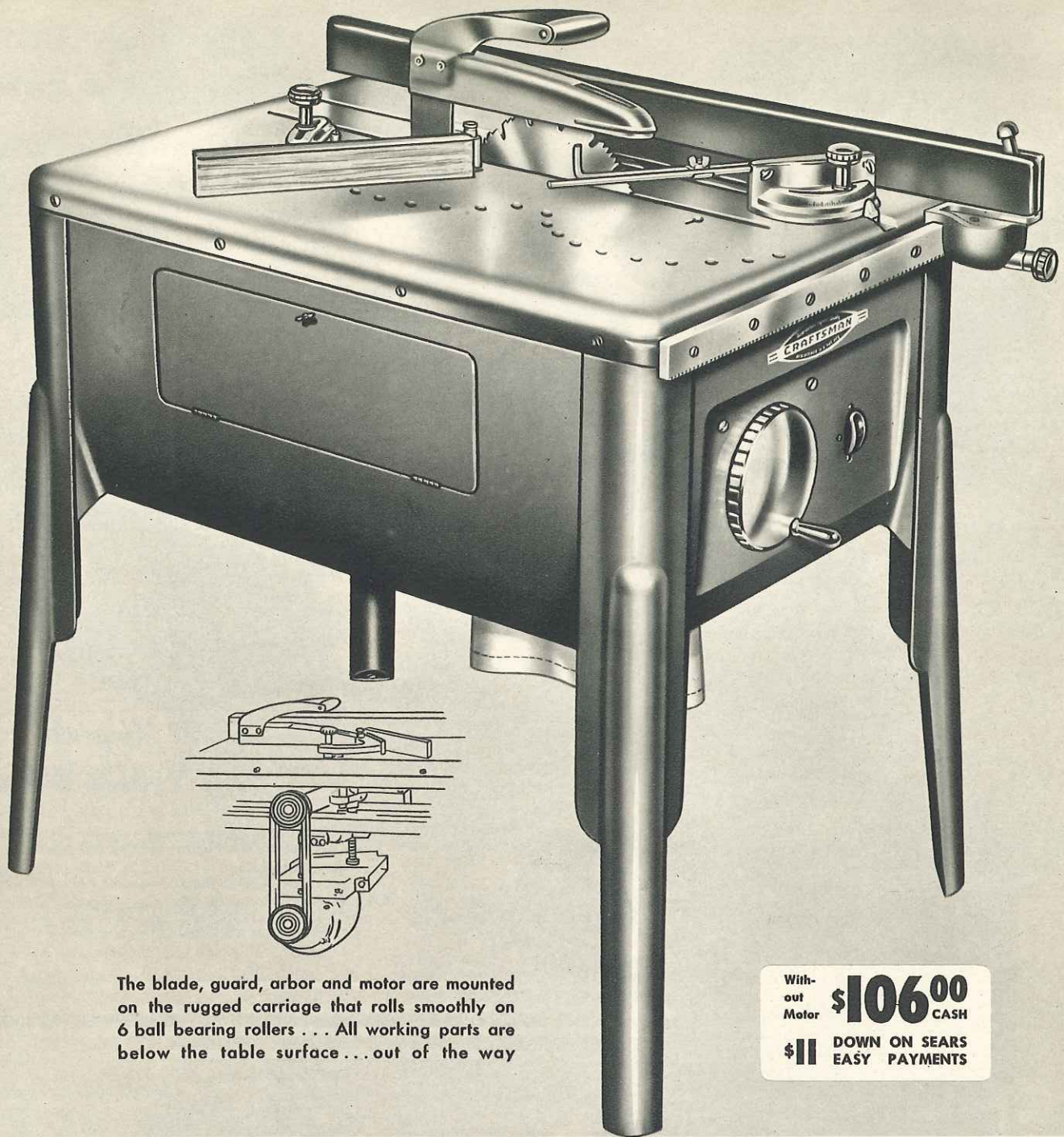

The blade, guard, arbor and motor are mounted on the rugged carriage that rolls smoothly on 6 ball bearing rollers . . . All working parts are below the table surface . . . out of the way

With-
out
Motor **\$106.00** CASH
\$11 DOWN ON SEARS
EASY PAYMENTS

CRAFTSMAN "100" Builder's Saw

Heavy duty type to meet all your construction and production needs

The most outstanding builder's saw of the year! Check the many features and specifications and you will know why! It's the perfect saw for cutting and ripping building materials, for cutting crating in shipping rooms and for making miter and dado cuts. Removable insert for dadoing. The sturdy steel frame, legs, and side panels welded into one solid unit . . . will withstand steady production use.

Extra large capacity. The 10-inch combination rip and crosscut blade allows you to make cuts up to 3 1/4 inches in depth. Saw travels full 15 1/2 inches. At any point in travel of saw the depth of cut can be easily adjusted by the large handwheel conveniently located at the front. Removable and adjustable saw guard raises and lowers with saw blade depending on depth of cut; also protects operator.

Lumber remains stationary. Forget about sliding long heavy lumber into the blade. Now . . . you simply hold lumber firmly on the table and move blade

through it by pulling convenient handle. Cuts large heavy work faster, easier and more accurately than the ordinary bench saw.

Extra large table. 35x24-inch table top is one-piece steel, stamped and coined. Sturdy ribbing braces are welded to under sides. Equipped with two miter gauges: left hand is used when work is stationary and blade is pulled through work; right hand is used when blade is stationary for making shorter cuts. Rip fence locks at both ends for better squaring accuracy in cutting. It moves along table by pinion in rack under guide bar. Arbor is mounted on two roller type needle bearings.

SPECIFICATIONS:

- Depth of cut, maximum 3 1/4 inches
- Blade, combination type 10-inch diameter 5/8-inch bore
- Bearings: arbor 2 sets of roller needle bearings
- Carriage rollers 6 sets of ball bearings

- Dado capacity:
- Width, maximum 1 1/4 inch
- Depth, maximum, with 6-in. dado saw . . . 1 1/4 inch
- Distance in front of blade (at miter gauge) . . 15 in.
- Arbor speed recommended 4200 R.P.M.
- Motor recommended, min. 3/4 H.P., 3450 R. P. M.
- Machine pulley (included) 2 1/2-inch double "V" groove
- Motor pulley (included) 3 in. double "V" groove
- Switch (included) 2 H.P. capacity
- Carriage travel, maximum 15 1/2 inches
- Miter cut, maximum 3 1/4 x 15 inches
- Miter graduations L. H. 1° in 180° radius
- Miter graduations R. H. 1° in 180° radius
- Table height 33 inches
- Over-all dimensions: Height (including handle) 40 inches; length 42 1/2 inches; width 27 inches.
- 99TM2262—Without motor. Shpg. wt. 160 lbs. **\$106.00**
- 99TM2266—With 3/4 H. P. 3450 R.P.M. capacitor ball bearing, 110-120-volt, 60 cycle A. C. motor. Shpg. wt. 208 lbs. **\$144.50**

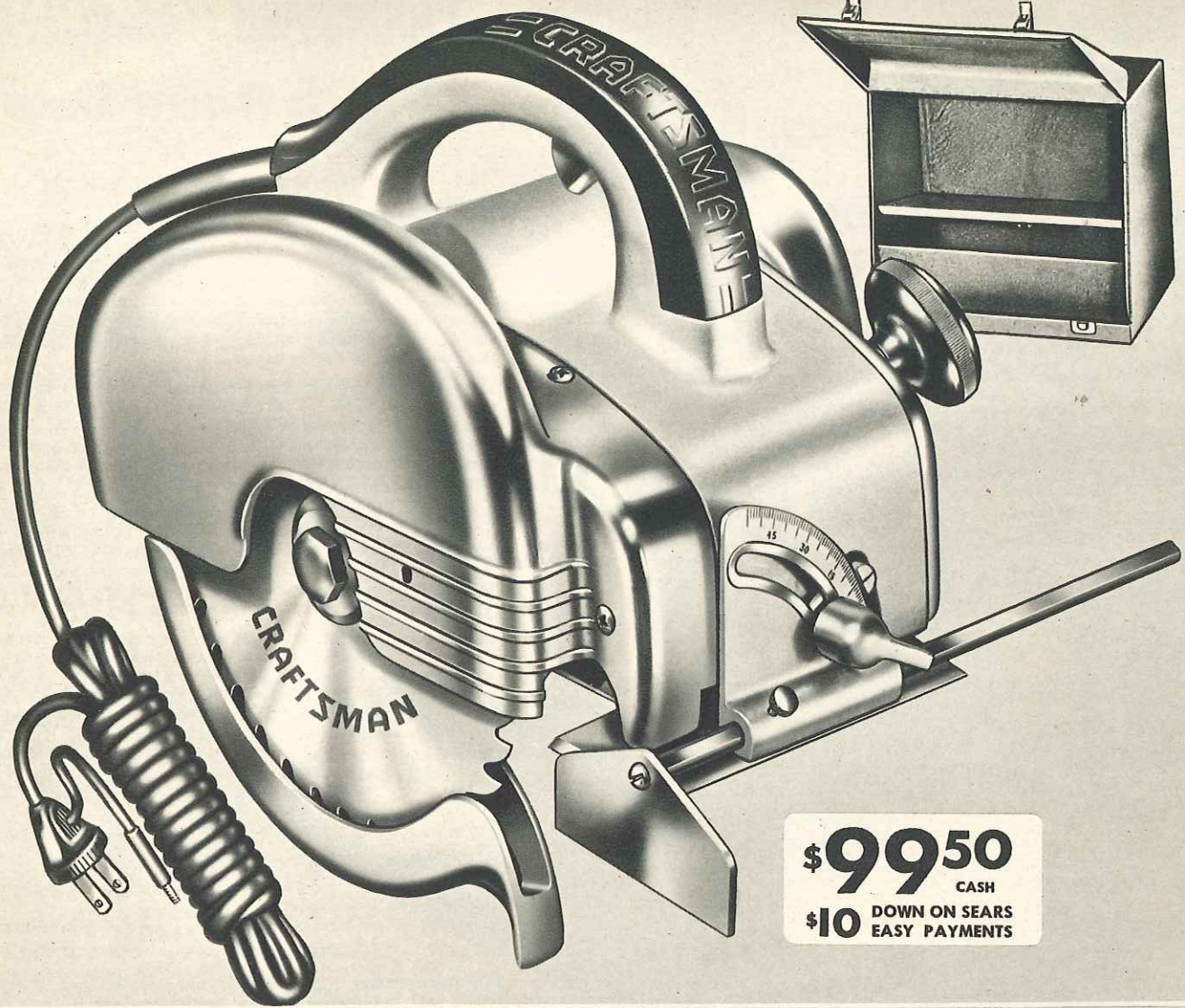

\$99.50
CASH
\$10 DOWN ON SEARS
EASY PAYMENTS



Perfect-fitting straight and compound miter cuts quickly and easily cut right on the job with this portable handsaw.

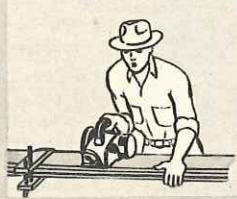

2 7/8-in. depth of cut permits you to cut several pieces at once in vertical position . . . up to 2-in. depth of cut at 45 degrees.



It's easy to cut large plywood panels; to notch and cut rafters, siding, and flooring. Saves you time and money.

CRAFTSMAN Electric Hand Saw

Cuts faster than any similar saw we know of . . . only \$10.00 Down

The rugged, portable electric saw that does any sawing operation 10 TIMES FASTER than ordinarily performed with a hand saw . . . actual tests proved it. And it's so easy to use. Do your ripping, crosscutting, mitering and notching and cutting rafters, flooring, panels and siding the modern speedy way . . . with a CRAFTSMAN 8-inch Electric Hand Saw. Tremendously useful in carpentry, building construction, crate and box making, etc.

Super-large capacity. The base is adjustable for depth of cut: From 0 to 2 7/8 inches in vertical position and 2 inches at 45 degrees. The 8-inch blade, mounted on right side for visibility and convenience, is protected at every angle by an automatic telescoping guard . . . rotates on needle bearings.

New close-coupled design. The motor and handle are mounted close to the blade . . . gives better balance . . . more efficient gear arrangement. Gears are made of helical cut alloy steel. One Zerk grease fitting

lubricates all the gears. Knob handle on the left side for two handed operation.

SPECIFICATIONS:

- Depth of cut, maximum: vertical position, 2 7/8 in. 45° position 2 inches
- Blade (included) diameter 8 inches bore 1/2 inch type combination
- Free blade speed 6400 R.P.M.
- Base adjustment: For depth of cut, 0 to 2 7/8 inches For angle of cut 45 to 90 degrees
- Bearings Double sealed SKF ball bearings
- Motor General Electric, universal; 110-120 volt A.C.-D.C.
- Switch Non-locking Trigger type, enclosed
- Sawdust blower Built-in
- Ripping Guide Built-in
- Over-all dimensions: Height (with handle) 11 1/4 inches; length 13 inches; width 9 inches

The lightweight frame is made of strong, die-cast aluminum alloy. Actual weight of this CRAFTSMAN Electric Hand Saw is only 19 pounds. A convenient 20-gauge steel carrying case is included with saw. Open-front type with shelf for carrying saw and space below for storing extra blades, cords, tools, etc. Size of case is 16x13 1/2x10 inches.

Complete with 8-inch blade, 10-foot 3 wire rubber covered cord, unbreakable plug, wrench and handy all steel carrying case. Shipping weight 38 pounds. 99 T 02560—CRAFTSMAN Electric Hand Saw . . . **\$99.50**

9 T 6455—Cut-off Wheel. For use on above saw. 8-inch diameter, 3/8-inch thick. Use for cutting tile, concrete, granite, cast iron, etc. Specify 1/2-inch bore. Shipping weight 8 ounces Each **\$1.69**

9 T 4940—CRAFTSMAN Combination Blade. For use on above saw. Made of tough alloy steel. 8-inch diameter; 1/2-inch bore. Shpg. wt. 1 lb. **\$3.35**

CRAFTSMAN "100"
REG. U.S. PAT. OFF.

12-inch Band Saw

Cuts wood 6 inches thick

Here's a mighty essential saw for all woodworking shops! You're able to saw curves in lumber up to 6 inches thick and to the center of a 24-inch circle with this CRAFTSMAN heavy duty Band Saw. This extra large, extra safe saw is designed to meet your toughest production problems. When equipped with special blades, it can be used for sawing asbestos, bakelite, paper, insulation, fiberboard, sheet metal, etc. When a rip fence (described below) is attached to the table, this saw is ideal for ripping lumber.

Large cutting capacity. The $14\frac{3}{16} \times 12$ -inch table tilts and locks to any angle up to 45° . . . adjusts with accurate tilt angle indicator. With the non-tilting extension the table size is $18\frac{3}{4} \times 14\frac{3}{16}$ inches. Regular table made of smooth ground heavy ribbed cast iron. In center of table, around the saw blade, is a soft aluminum throat plate that prevents damage to blade in case of breakage.

Extra safe. Notice the fully enclosed design! It's sleek, streamlined and safe. Safe because all the working parts, except the actual cutting section of the blade, are completely enclosed in a sturdy steel frame or casing. No chance of injury to the operator if the blade should accidentally break! It's inside the casing where it can't fly out. This is one of the safest band saws ever built.

Rugged superior construction. The two rubber-tired cast iron wheels used in this CRAFTSMAN Band Saw are much heavier than conventional steel or die cast wheels found in other saws. The lower wheel is the driver and is connected by belt to the motor. This feature and the extra weight gives a flywheel effect for exceptionally smooth operation even on deep cuts. The upper wheel raises and tilts on sturdy mounting to adjust the blade tracking and tension. Each wheel runs on double sets of ball bearings.

\$69⁵⁰
CASH

Without Motor

\$7 DOWN . . . ON
EASY TERMS

Accurate cutting. The saw guides, one above and one below the table, hold the blade firmly but gently in place . . . keep the blade from twisting and wobbling . . . enables you to make true, accurate cuts. The guides are made of hardened steel and have oil impregnated adjustable bronze blocks and ball bearing thrust wheels.

SPECIFICATIONS:

- Depth of throat, maximum 12 inches
- Depth of cut, maximum 6 inches
- Table size $12 \times 14\frac{3}{16}$ inches
- Table size with auxiliary table (included) $18\frac{3}{4} \times 14\frac{3}{16}$ inches
- Length of blade80 inches
- Width of blade (one included) $\frac{1}{2}$ -inch
- Bearings Four sets ball bearings
- Size of each wheel 12 inches
- Machine pulley (included) 5 inches
- Motor pulley (not included) 2 inches
- Motor recommended minimum $\frac{1}{8}$ H.P. 1750 R.P.M.
- Recommended speed: Revolutions per minute 690
Feet per minute 2200
- Mounting dimensions $5\frac{1}{2} \times 13\frac{3}{4}$ inches
- Over-all dimensions: Height 35 inches; width $24\frac{1}{16}$ inches; depth $14\frac{3}{16}$ inches.

The strong, rigid steel column and husky cast iron castings form a super strong frame. All parts of the frame are locked in perfect alignment . . . helps eliminate vibration and insure smoothness of operation. Shipping weight 104 pounds.

99 TM 2337—CRAFTSMAN 12-inch Band Saw without motor **\$69.50**

99 TM 2379—CRAFTSMAN 12-inch Band Saw with $\frac{1}{8}$ H.P. 1750 R.P.M. ball bearing split phase, 110-120-volt, 60-cycle A.C. motor. Shipping weight 134 lbs. **\$88.00**

Rip Fence for above Band Saw

Here's a very handy band saw accessory for use when making straight cuts on thin pieces of lumber. The best results can be obtained if you use it with a $\frac{1}{2}$ -inch blade. $\frac{1}{2}$ -inch blades have little tendency to be deflected by heavy grain in wood. Equipped with locks at front and rear for better alignment. Comes complete with all the necessary fittings. (Illustrated at left.) Shipping weight 5 pounds.

9 T 2343—Rip Fence for 99 TM 2337 Band Saw above **\$4.75**

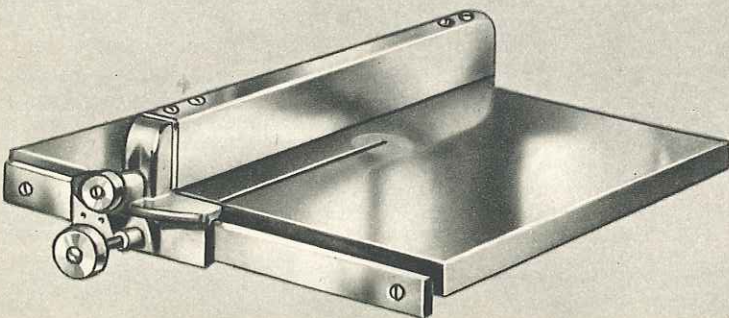
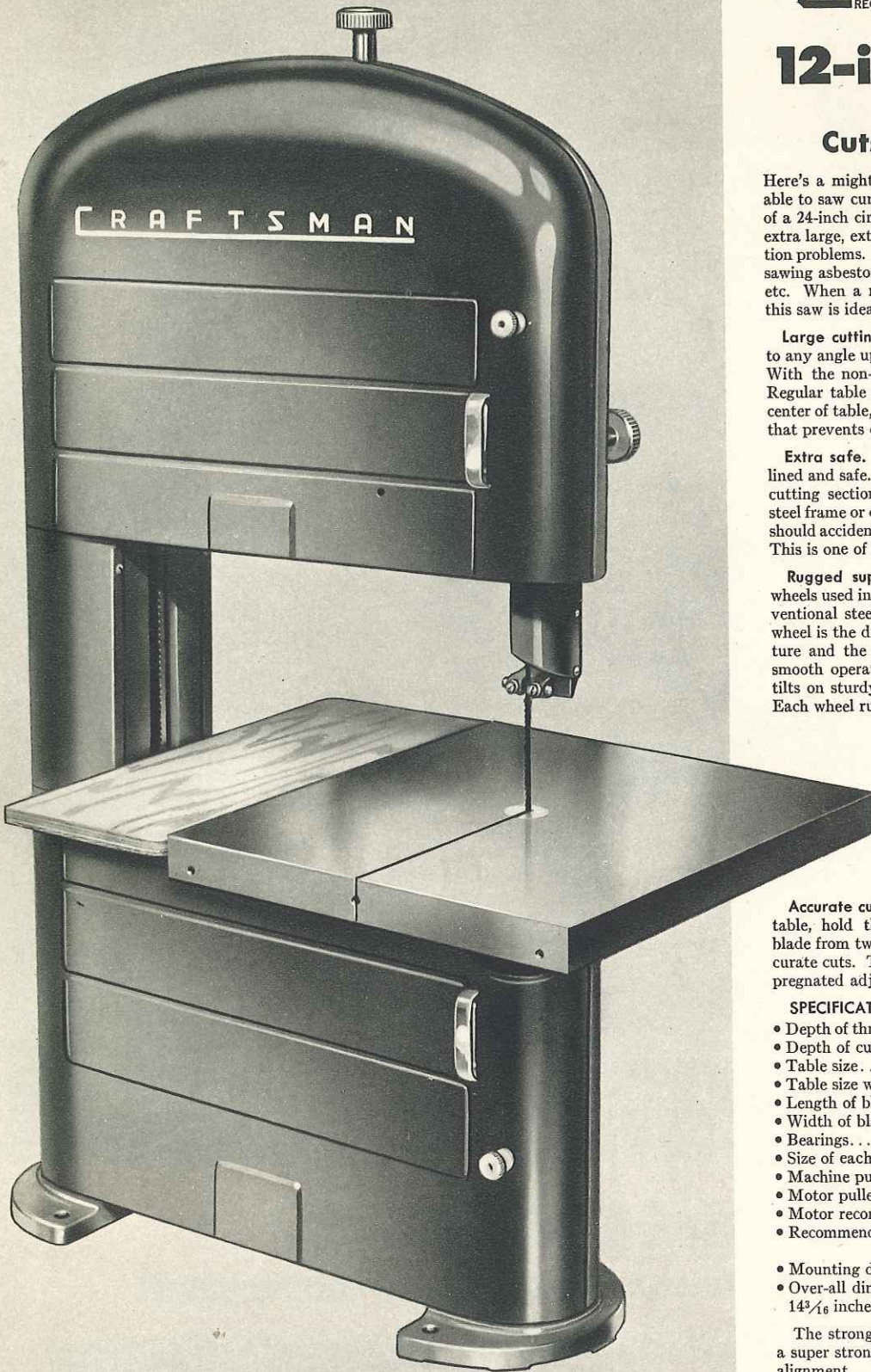

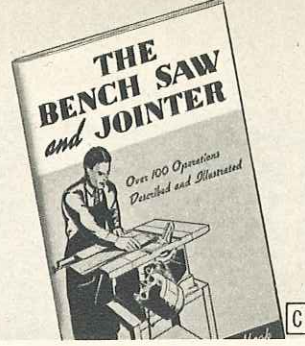
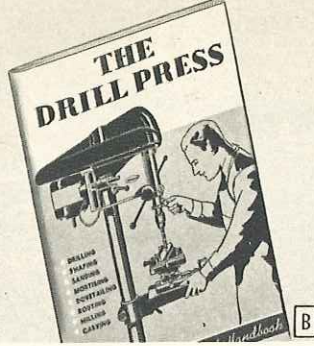
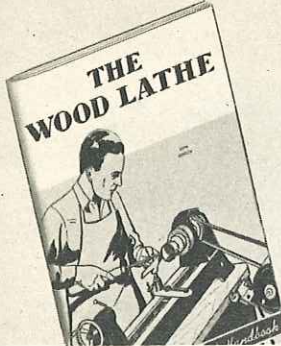

Helpful Books • • A world of technical and general information to help you make and save money

The Wood Lathe

A CRAFTSMAN power tool hand-book that explains the construction and operation of the wood lathe. Enables even the novice to do excellent work. Contains over 100 actual photographs and step-by-step illustrations. Tells how to turn spindles, how to do elementary metal turning, how to do grinding, sanding, finishing and many other operations. Easy to read and understand. Paper bound. 32 pages. *Postpaid.*

9 T 2920—Shpg. wt. 2 oz. 30c

The Drill Press

B A superb CRAFTSMAN manual for the home craftsman and shop owner. Explains in detail the construction features and operations of the drill press. Over 100 actual photographs and step-by-step illustrations explain vividly how to do drilling, shaping, sanding, mortising, dovetailing, routing and carving. Describes completely the uses of accessories and suggests many helpful homemade aids. Paper bound. 32 pages. *Postpaid.*

9 T 2921—Shpg. wt. 2 oz. 30c

Bench Saw and Jointer

C Useful CRAFTSMAN instruction and information manual that describes the construction and over 100 operations of the circular saw and jointer. Numerous actual photographs and step-by-step illustrations tell you exactly what to do and how to do standard and special sawing operations, and how to sharpen saws and jointer knives. Will help make your bench saw and jointer more useful. Paper bound. 32 pages. *Postpaid.*

9 T 2923—Shpg. wt. 2 oz. 30c

Metal Lathe Manual

D A complete, up-to-date manual of metal lathe operations and machinists' tables. The easy-to-follow directions give you a sound, practical explanation of the construction of the metal lathe. An ideal book for students, apprentices, machinists and experienced lathe operators. Replete with actual photographs and pen and ink drawings. Index tabs separate each section. Paper bound; spiral back. 234 pages. *Postpaid.*

9 T 2925—Shpg. wt. 1 lb. \$1.35

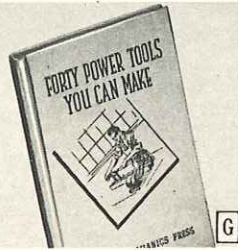
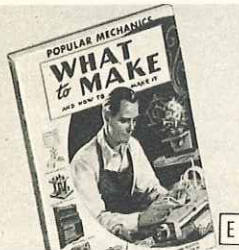

Popular Mechanics What to Make

E Handy book that tells you what to make and how to make it. Hundreds of practical ideas you can use around the house . . . things you can make with simple tools. Get fun and profit from your spare time. You don't have to be an expert to follow the simple instructions.

Complete explanation of each subject is given; illustrated with pictures and drawings. Paper bound. 208 pages. *Postpaid.* Shpg. wt. 1 lb. 9 T 2914 \$1.00

Popular Mechanics Shop Notes

F Here are hundreds of money making, time and labor saving ideas you can use. It's the ideal guide for all mechanics . . . for any man who uses tools. Gives excellent general and technical information on lathe operation, drafting, shop practice, use of hand and power tools, time and money saving short cuts, etc.

Hundreds of illustrations. Paper bound. 240 pages. *Postpaid.* Shpg. wt. 1 lb. 9 T 2915 \$1.00

40 Power Tools You Can Make

G Want a motorized workshop? Here's a book that tells you how to construct it at low cost in your own home.

This book explains in non-technical style just how to go about making 40 different machines such as drill presses, wood and metal lathes, band saws, etc. Cloth bound. 96 pages. Pictures, photographs and drawings show how to make these machines. *Postpaid.* Shpg. wt. 1 lb. 9 T 2640 \$1.25

The Boy Mechanic

H From front to back cover, this book is packed with thrilling, instructive jobs that your boy . . . any boy . . . can do in his spare or leisure time.

In easy-to-understand English, it tells how to mount small animals; how to build midget autos, boats, models, toys, games and hundreds of other things. 564 pictures and plans illustrate each item. Cloth bound. 224 pages. Shpg. wt. 1 lb. *Postpaid.* 9 T 2641 \$2.00

Build a Boat for Pleasure or Profit

J It's easy to build your own boat when you use this complete boat building book. It gives you detailed instructions, pictures and diagrams on how to build 17 low-cost boats at home.

The 17 types include row-boats, canoes, sail boats, ice-boats, plywood outboard, inboard runabout, cabin cruiser and many other interesting projects. Prepared for home builder with limited tools and money. Cloth bound. 192 pages. *Postpaid.* Shpg. wt. 1 lb. 9 T 2642 \$1.50

Concrete Handbook

K Beautify your garden . . . make your own tennis court . . . construct your own sewage system . . . even lay the foundation for your garage or home. This book tells you many things you need to know to make use of concrete. Do this fascinating work yourself or for others. You'll be able to save or make money.

Book contains instructions with pictures. Cloth bound. 96 pages. *Postpaid.* Shpg. wt. 1 lb. 9 T 2643 \$1.50

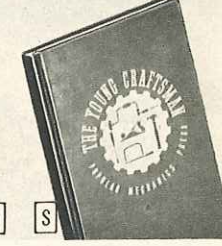
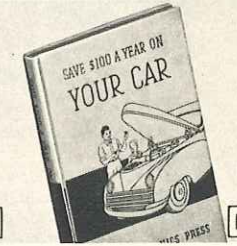
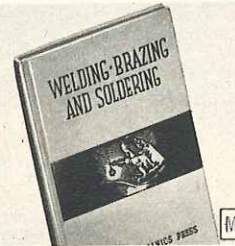

Garden Book

L Would you like to landscape your drab backyard or re-seed your lawn? You can if you use this helpful, instructive garden book.

It shows and tells you the best ways to grow grass, flowers and vegetables and how to landscape your yard. Also tells you how to make outdoor furniture, fences, trellises, fireplaces, etc. Cloth bound. 96 pages. *Postpaid.* Shpg. wt. 1 lb. 9 T 2644 \$1.00

Welding, Brazing and Soldering

M Welding isn't difficult when you use this informative book! By doing your own welding and soldering, you'll be able to save money and time.

This book tells you how to construct welding equipment and how to use it. Gives instructions on small arc welders, arc torches, oxy-acetylene welders, spot welders, and soldering irons. 96 pages. Cloth bound. Shpg. wt. 1 lb. *Postpaid.* 9 T 2645 \$1.25

Painting and Furniture Refinishing

N Everyone likes to paint. Learn how to do it the right way! Here is a collection of helpful articles for craftsmen, home owners, painters and handy men.

Gives information on paints, varnishes, stains, brushes, etc. With pictures and drawings, it shows you how to spray paint, to paint and stain furniture, refinish floors, restore antique furniture, etc. 96 pages. Cloth bound. *Postpaid.* Shpg. wt. 1 lb. 9 T 2646 \$1.50

Your Car

P This important book has something of value for every auto driver, car owner, mechanic and service man.

It describes hundreds of simple auto repairs, shortcuts, ways to save time and money on car and garage. By taking advantage of the information in this book, you'll be able to save \$100 a year on your car. Cloth bound. 184 pages. Shpg. wt. 1 lb. *Postpaid.* 9 T 2647 \$1.50

Photo Guide

R This guide to better photography illustrates and describes in simple language how you can, at low cost, make your own equipment such as enlarger, tripod, photo trimmer and numerous other time saving gadgets.

It also contains articles by top-rate photographers from all over the country on getting better pictures with your camera. Cloth bound. 188 pages. *Postpaid.* Shpg. wt. 1 lb. 9 T 2648 \$1.50

The Young Craftsman

S Here's that book for "boys" from 10 to 60. It will entertain as it trains mind and hands. . . . help to stimulate imagination and bring out creativeness, etc.

Shows how to make 450 things with simple hand tools and inexpensive or waste materials. No skill needed . . . just spare time and desire to learn. Over 1100 pictures. Cloth bound. 208 pages. *Postpaid.* Shpg. wt. 1 lb. 9 T 2649 \$1.50

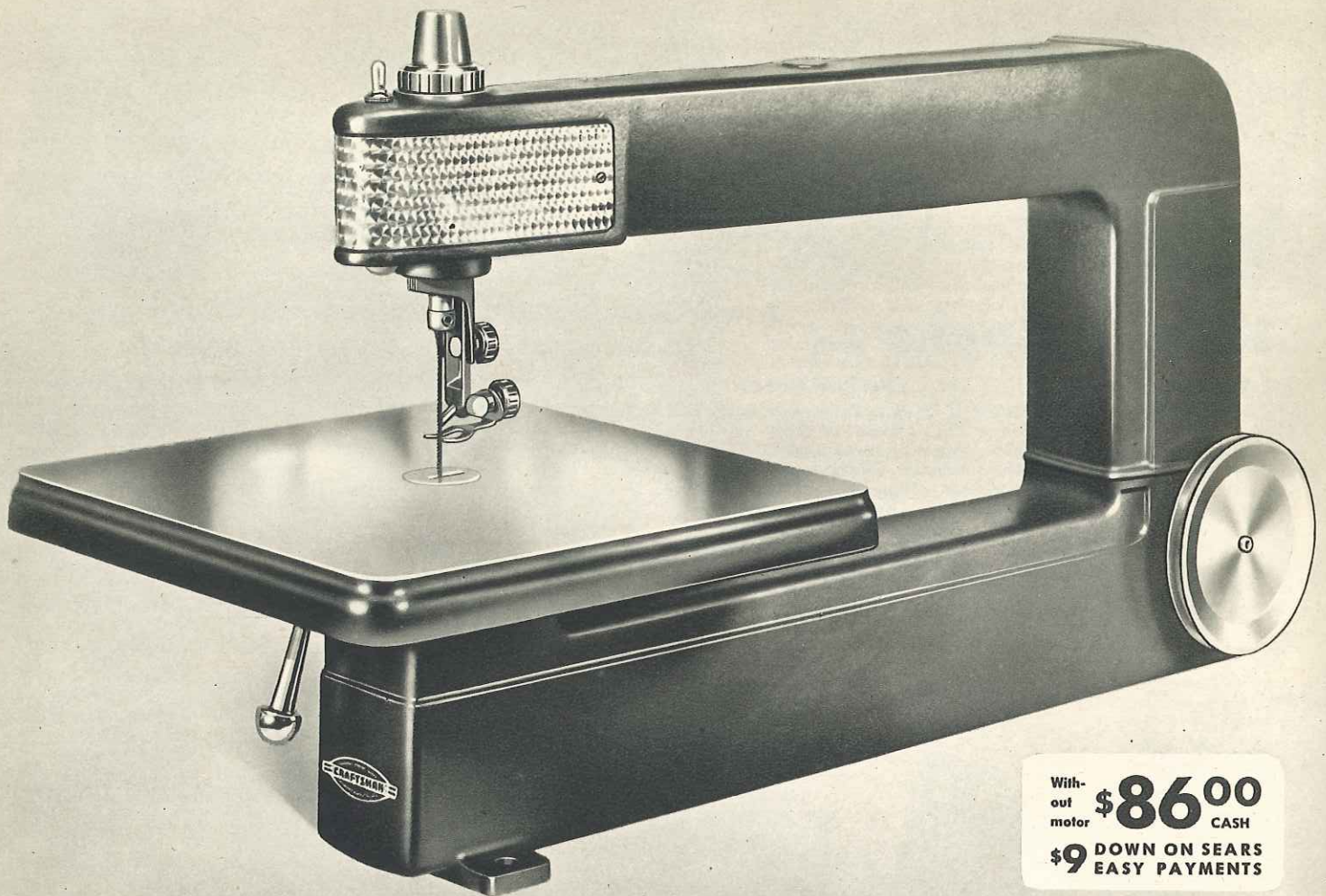

With-
out
motor **\$86⁰⁰** CASH
\$9 DOWN ON SEARS
EASY PAYMENTS

CRAFTSMAN "100" Jig Saw

24-inch capacity for professional use

Woodworkers! Pattern makers! Printers! Engravers! Sign makers! Here's an extra large capacity jig saw . . . cuts to center of a 48-inch circle on materials up to 2-inches thick . . . that will be a valuable asset in your plant or shop. Besides sawing wood, this CRAFTSMAN "100" jig saw, with the sensational "Walking Beam" drive action, is ideal for sawing metals, plastic, fiberboard and other materials. Especially designed for making intricate cuts and for doing fine pattern work. Read the full explanation (at the right) of the "Walking Beam" drive action. You'll want a CRAFTSMAN 24-inch jig saw in your shop today.

Extra large size table. Notice the 16x16-inch adjustable table. Plenty of working surface there. And it can be tilted 45 degrees either to the right or left or it can be tilted to the front or rear. To make this jig saw more adaptable to the delicate inside or outside scrollwork or fretwork, the blade and chuck swivel a full 90 degrees.

Lifetime lubrication. No need to worry about burned out bearings . . . no spoiled work due to oil spots . . . this jig saw is permanently lubricated. Special impregnated bearings supply all the lubrication necessary for the life of the saw. Entering cuts at sharp angles are possible because the new blade support guides the blade above and below the work . . . close to the working surface . . . reduces blade breakage, too. Narrow, almost tissue paper thin cuts are possible on this jig saw because of the smooth, exclusive "Walking Beam" drive action. The hold down foot prevents lifting work off the table on the upward stroke of the blade.

Built-in blower. A blower, located in the head, delivers a constant air blast through the upper chuck. Keeps your work free of sawdust. Ideal when following a pattern. Lamp, built in the head, lights up the working area. In actual operation, this CRAFTSMAN jig saw is practically vibrationless and noiseless. Vibration reduced by the use of "Walking Beam" drive action which eliminates the usual jerky return spring and crankshaft.

Check the following specifications. It's just THE saw you need for your production work.

SPECIFICATIONS:

- Depth of throat 24 inches
- Depth of cut, maximum, in wood 2 inches
- in plastic 1½ inches
- in brass ¾ inch
- in aluminum and zinc 5/8 inch
- Table size 16x16 inches
- Table swivels 90 degrees, tilts up to 45 degrees
- Motor recommended, min. . . ¼ H.P. 1750 R.P.M.
- Machine pulley (included) . . . 6½-inch "V" type
- Motor pulley (not included) . . . 2-inch and 4-inch
- Speed 530 and 1070 R.P.M.
- Work lamp (with cord and plug) . . . 7½ watt; built into the head; convenient switch
- Sawdust blower Built into head
- Mounting dimensions 5½x30½ inches
- Over-all dimensions: Height 21½ inches; length 39¾ inches; width 16½ inches

The motor (not included) can be mounted above, below or behind the machine pulley. Pulley drive is at the rear on the side of the base; away from the working area for safety of operation. One 6-inch plain end blade included. Shpg. wt. 124 lbs.

99 TM 2339—24-inch jig saw without motor.. \$86.00

99 TM 2361—24-inch jig saw with ¼ H.P. 1750 R.P.M. split phase ball bearing 110-120 volt, 60-cycle A.C. motor. Shipping weight 154 lbs.. \$104.50

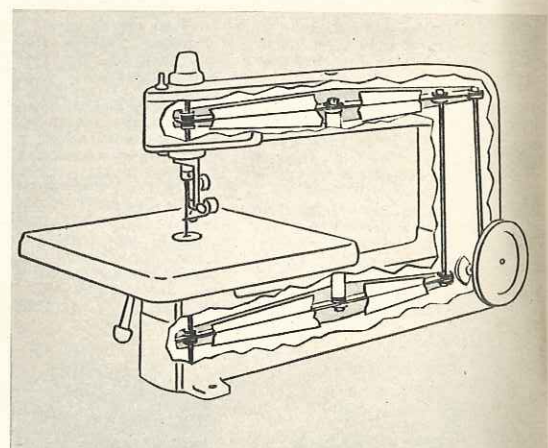

"Walking Beam" Action

"Walking Beam" type of drive action is an "H" shaped stamped channel section. An exclusive feature of this new CRAFTSMAN "100" Jig Saw. This drive action operates through double bearing guides above and below blade. Eliminates the need for return spring (power delivered in both up and down stroke). Maintains uniform tension of blade on both up and down stroke to give blade longer life, even when using fine fret or jewelers' blades. This new design greatly minimizes blade breakage and vibration. It also eliminates any need for crankcase. And you'll find it's practically noiseless in operation.

CRAFTSMAN
REG. U. S. PAT. OFF.

"80" Jig Saw

18-inch work capacity

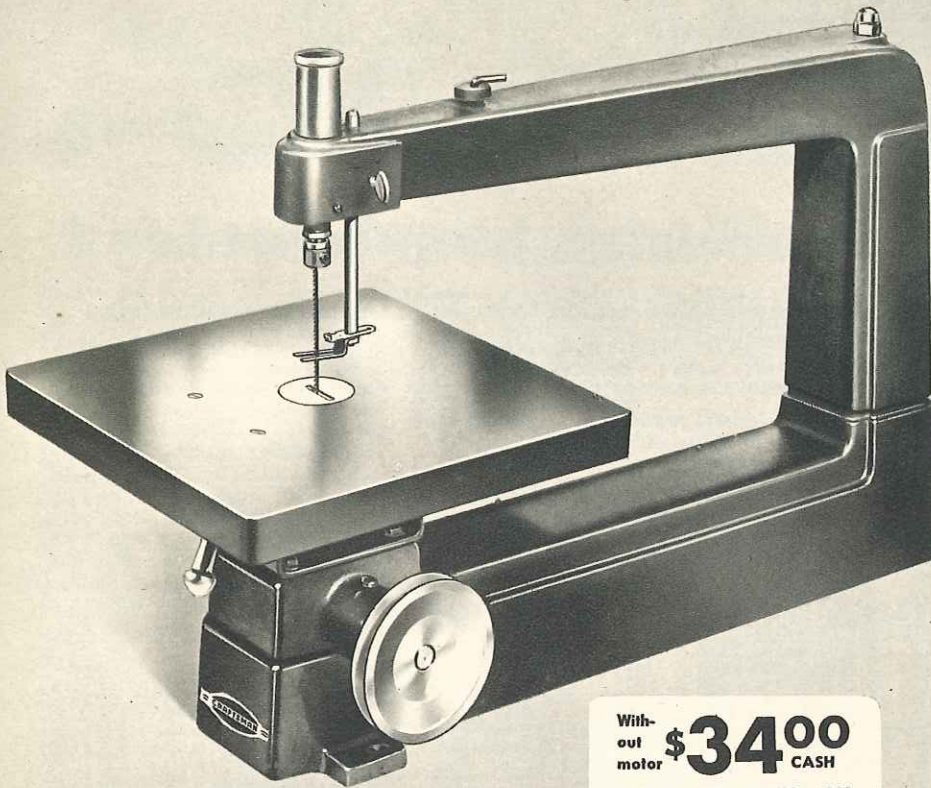

With-
out motor **\$34⁰⁰** CASH
\$3.50 DOWN... ON EASY TERMS

- Cuts to center of 36 inch circle
- Handles material up to 2 inches thick

This CRAFTSMAN 18-inch Jig Saw is especially designed for your professional or hobby use. The 12x12-inch table provides a large working surface. The smooth ground, cast iron table can be tilted up to 45 degrees... locked in angle position desired.

Modified Scotch yoke action runs in a bath of oil. This gives the saw a well balanced, smooth cutting action. The new, strong blade chuck rotates 90 degrees; enables you to rip pieces longer than 18 inches. No twisting of blade... the shoe in chuck gives a firm grip between the blade and the clamping member.

Fully enclosed coil spring keeps the blade tight for smoother operation. Equipped with adjustable hold down and blade guides. Built-in air pump clears sawdust from working area. Oilite bronze main bearings.

SPECIFICATIONS:

- Depth of throat..... 18 inches
- Depth of cut, maximum..... 2 inches
- Table size..... 12x12 inches
- Machine pulley (included)..... 4-inch single groove
- Motor pulley (not included)..... 2 inches
- Motor recommended, minimum 1/2 H.P. 1750 R.P.M.
- Speed..... 860 R.P.M.
- Sawdust blower..... Built into head
- Mounting dimensions..... 5 1/4 x 22 7/16 inches
- Over-all dimensions: Height 17 3/8 inches; length 29 inches; width 12 inches.

Strong cast iron frame has three point mounting of base which eliminates cross strain. Upper arm is removable for saber sawing and filing. Uses five-inch plain end blade (one included). Shpg. wt. 72 lbs.

- 99 TM 2315—18-inch jig saw without motor..... **\$34.00**
- 99 TM 2360—18-inch jig saw with 1/2 H. P. 1750 R. P. M. split phase ball bearing 110-120 volt, 60 cycle A. C. motor. Shipping weight 102 pounds..... **\$52.50**



CRAFTSMAN "40" Magnetic Jig Saw

\$12⁹⁵

Our popular, low priced jig saw that operates without a motor or belt. Just plug it in and go to work. That's all there is to it. The magnetic power unit, located in the base, moves the blade so rapidly... 7200 strokes per minute... that super-smooth edges are produced. No sanding necessary! Cuts to the center of a 22-inch circle.

The safe, easy-to-operate hobby tool that every member of the family can use and enjoy. Less dangerous for a child to use than a hammer. *It's more than a toy. It's a rugged, well-made power tool.* Just the thing for making hundreds of articles from wood, plywood, thin plastic, or metal.

No motor to buy! No belt! No gears! No oiling necessary... you don't have to worry

about parts burning out from lack of oil... or about oil spots on work. Portable too... can be used anywhere. So clean you can use it on the kitchen table.

SPECIFICATIONS:

- Depth of throat..... 11 inches
- Depth of cut, maximum in wood... 1/2 inch
- Table size..... 8 1/2 x 8 inches
- Over-all dimensions: Height 10 1/2 inches, width 8 1/2 inches; length 16 1/2 inches

All metal construction; non-slip rubber feet. Comes complete with one 5-inch pin-end blade. 5 1/2 ft. of connecting cord and operating instructions. Use on 110-120 volt 60 cycle A. C. only.
99 T 02632—Shpg. wt. 14 lbs. **\$12.95**
9 T 2690—Extra blades for above jig saw. 6 blades, each 5 in. long. Shpg. wt. 1 oz. **.25c**

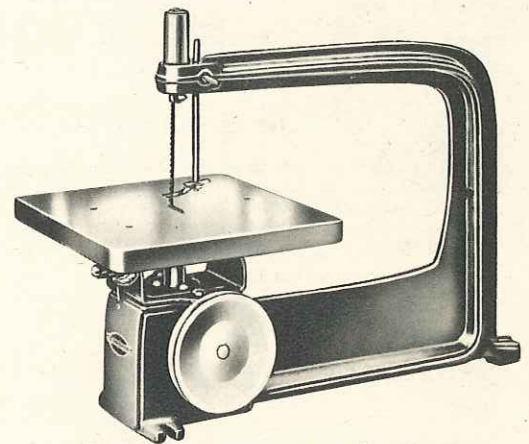

CRAFTSMAN "40" Jig Saw

\$17⁰⁰

- Cuts to center of 24-inch circle
- Handles work up to 1 inch thick

A smooth operating small jig saw. Just the saw for use in your hobby shop or home work shop. With this CRAFTSMAN 12-inch Jig Saw you have a full 9x9-inch smooth ground cast iron table... can be tilted to any angle up to 45 degrees... can be locked in angle position.

Balanced modified Scotch yoke action runs in a bath of oil. The fully enclosed coil type spring eliminates blade whip. Uses 5-inch pin type blade (one included). Adjustable blade guide and hold down.

SPECIFICATIONS:

- Depth of throat..... 12 inches
- Depth of cut, maximum..... 1 inch
- Table size..... 9x9 inches
- Machine pulley (included)..... 4-inch single groove
- Motor pulley (not included)..... 2 inch
- Motor recommended, minimum 1/4 H.P., 1750 R.P.M.
- Speed..... 860 R.P.M.
- Mounting dimensions..... 16 1/4 x 4 1/4 inches
- Over-all dimensions: Height 14 3/32 inches; length 17 9/16 inches; width 9 inches. Shpg. wt. 32 lbs.

- 99 TM 02179—12-in. jig saw without motor..... **\$17.00**
- 99 TM 02184—12-in. jig saw with 1/4 H.P., 1750 R.P.M. split phase sleeve bearing 110-120 volt, 60 cycle A. C. motor. Shpg. wt. 56 lbs. **\$30.50**

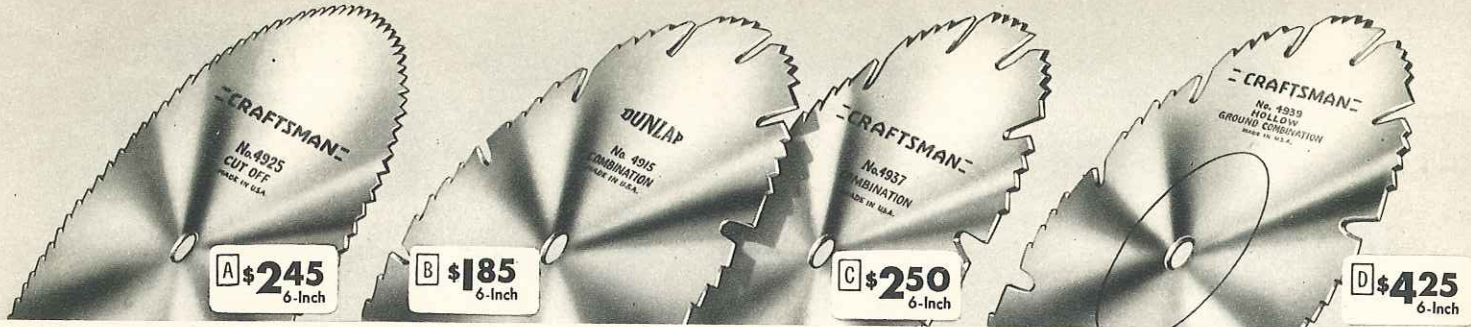

Circular Saws . . . precision heat treated

Crosscut and Rip Saws

A CRAFTSMAN. Our finest circular crosscut and rip saws. Professional quality. Made to stand up under day-after-day production work in factories, shops, etc. Made of special "Super-Tuff" steel, precision heat treated. Hand hammered to correct tension. Hand set and filed.

DUNLAP. (Not illustrated.) Made of fine quality tough high carbon steel, hardened and tempered. Hand hammered to correct tension. Hand set and filed.

State center hole size and diameter wanted.

CRAFTSMAN					9 T 4925	9T4926
Diam., In.	Gauge	Center Hole, In.	R.P.M.	Shpg. wt.	Crosscut	Rip
6	18	1/2 or 5/8	5000	8 oz.	\$2.45	\$2.45
7	18	1/2 or 5/8	4750	13 oz.	2.95	2.95
8	18	1/2 or 5/8	4500	1 lb.	3.35	3.35
10	16	3/8 or 1/2	3600	1 lb. 12 oz.	4.25	4.25
12	15	3/4 or 1	3000	2 lbs. 11 oz.	5.50	5.50
DUNLAP					9 T 4911	9T4913
6	18	1/2 or 5/8	5000	10 oz.	\$1.60	\$1.60
7	17	1/2 or 5/8	4750	13 oz.	1.80	1.80
8	17	1/2 or 5/8	4500	1 lb.	2.05	2.05
10	16	3/8 or 1/2	3600	1 lb. 12 oz.	2.45	2.45

Flat-ground Combination Saws

A combination saw is the handiest of all circular saws. Practically three saws in one. Can be used equally well for crosscutting, ripping or mitering in hard or soft wood.

B DUNLAP. Good general purpose saw. Tough, high carbon steel, hardened and tempered. Hand hammered for proper tension. Teeth hand set and filed.

C CRAFTSMAN. Our finest saw of this type. Special "Super-Tuff" steel accurately heat treated and hardened . . . far superior to ordinary high carbon steel. Hand hammered for proper tension. Expertly hand set and filed.

State center hole size and diameter wanted.

DUNLAP					CRAFTSMAN
Diam., In.	Gauge	Center Hole, In.	R.P.M.	Shpg. wt.	9 T 4915
6	18	1/2 or 5/8	5000	8 oz.	\$1.85
7	17	1/2 or 5/8	4750	13 oz.	1.95
8	17	1/2 or 5/8	4500	1 lb.	2.25
10	16	3/8 or 1/2	3600	1 lb. 12 oz.	2.65
12	15	3/4 or 1	3000	2 lbs. 9 oz.	5.50

9 T 4935—7-inch Combination Blade for our former model Electric Hand Saw 2186 which has diamond shaped arbor. Shpg. wt. 12 oz. (Not illustrated) **\$2.95**

Hollow-ground Saws

D CRAFTSMAN Combination type. Taper grinding makes this the best saw for all-around work. Runs with less set. Makes the smoothest cut of any circular saw . . . smooth enough to glue without sanding. Specially filed for ripping, crosscutting or mitering. Special "Super-Tuff" steel, heat treated for toughness . . . far superior to ordinary high carbon steel . . . stays sharp much longer. 3-gauge taper grinding provides ample clearance for free, easy cutting. Hand hammered for proper tension.

9 T 4939—State center hole size and diameter of saw wanted.

Diam. In.	Gauge Taper	R.P.M.	Center Hole, In.	Shpg. wt. Lbs. Oz.	Price
6	16 to 19	5000	1/2 or 5/8	8	\$4.25
7	15 to 18	4750	1/2 or 5/8	12	4.95
8	15 to 18	4500	1/2 or 5/8	1	5.95
10	14 to 17	3600	3/8 or 1/2	10	7.75
12	13 to 16	3000	3/4 or 1	2	11.25



NOTE

Above view shows dado saw assembled. With dado saws, you can use your bench saw for dadoing, grooving, rabbeting, tenoning, etc.

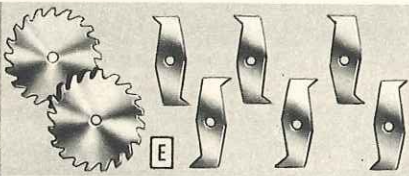

DUNLAP 4-in. Dado Set

E Makes your bench saw much more useful. A well made set at a low price. Made of tough, hardened steel. **\$349**

9 T 4887—2 outside saws, 6 chippers. 1/2-inch hole. Shipping weight 15 ounces. Set \$3.49

9 T 4883—Outside dado saw only. Shipping wt. 6 oz. **98c**

9 T 4880—Inside chipper only. Shipping weight 3 oz. **35c**

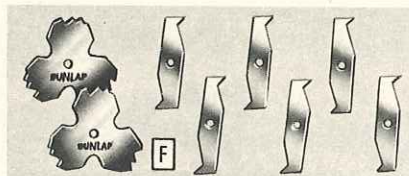

DUNLAP 5 1/2-in. Dado Set

F Good quality for general dado work. Tempered high carbon steel. Set includes: two 3/4-inch thick outside saws, and six 1/8-inch inside chippers. Shipping weight 1 pound 10 ounces.

9 T 4888—With 1/2-in. hole. Set \$4.95

9 T 4889—With 5/8-in. hole. Set 4.95

9 T 4884—Outside Saw only. Specify 1/2 or 5/8-in. hole. Shpg. wt. 9 oz. **\$1.55**

9 T 4881—Inside Chipper only. Specify 1/2 or 5/8-in. hole. Shpg. wt. 3 oz. **65c**

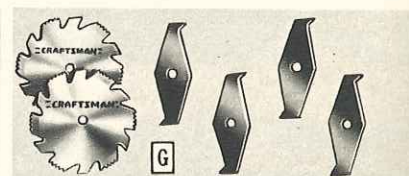

CRAFTSMAN 6-in. Dado Set

G Professional quality. Precision-ground perfectly matched chippers. Tempered high carbon steel. Set includes two 1/2-inch thick outside saws, one 1/4-inch chipper, two 1/8-inch chippers, one 1/8-inch chipper. Shipping weight 3 pounds 8 ounces. **\$1295**

9 T 4874—With 1/2-in. center hole. Set \$12.95

9 T 4875—With 5/8-in. center hole. Set 12.95

Separate Dado Saw Parts. Specify 1/2 or 5/8-in. hole.
 9 T 4876—Outside Saw. Shpg. wt. 8 oz. Each \$4.95
 9 T 4877—1/8-in. Chipper. Shpg. wt. 3 oz. 98c
 9 T 4878—1/8-in. Chipper. Shpg. wt. 3 oz. \$1.55
 9 T 4879—1/4-in. Chipper. Shpg. wt. 3 oz. 1.75

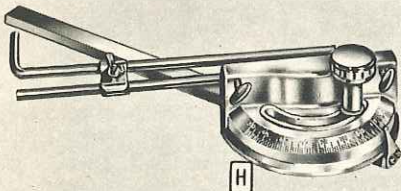

Miter Gauge

H CRAFTSMAN. A high quality, accurately scaled miter gauge for the man who wants to make his own saw table. Scaled from 30 to 90 degrees right and left. Long bar for miter groove in table top aids in making accurate cuts. Fitted with adjustable stop rods for repetitive cuts. Attractive chromium plated knobs. Rust-resisting cadmium plated finish on other parts. Shipping weight 4 pounds. **\$495**



Saw Mandrels for making your own table saws, grinders, etc.

J DUNLAP Bronze-Bearing Mandrels. 2-inch double V pulley for flat belt, single or multiple V-belt drive. Steel shaft; stamped steel flanges. Set collar takes up end play. Oil plugs. Length 14 in. **\$349**

9 T 4946—State size. Size 00. 3/8-inch shaft turned down to 1/2-inch at ends. Shipping weight 7 lbs. \$3.49

Size 0. 3/8-inch shaft turned down to 5/8-inch at ends. Shpg. wt. 8 lbs. **\$3.89**

K CRAFTSMAN Ball-Bearing Mandrels. Streamlined cast iron housing. Improved, compact design. Oversize precision ball bearings are grease sealed for protection against dirt. **\$610**

9 T 4948—Size 00. 5/8-inch shaft turned down to 1/2 inch at ends. Length 9 1/2 inch. Shipping weight 3 lbs. 8 oz. \$6.10

9 T 4949—Size 0. 5/8-in. straight shaft with 3/8 inch ends. Length 11 1/2 inches. Shipping weight 4 pounds. **\$6.35**

L Heavy Duty Saw Mandrels. Precision built. High speed babbitted bearings. Machined steel collars. Cold rolled steel shaft. Set collar. With bolts. State size wanted. **\$315**

Size 00

Size	Pulley diameter and face	Shaft Size inches	Shaft Size at end inches	Shpg. wt.	99 T 04947 Left hand threads	99 T 04932 Right hand threads
00	2 x3 in.	16 x 3/4	1 1/2	7 lbs.	\$3.15	\$3.15
0	2 x3 in.	16 1/2 x 3/8	1 1/2	15 lbs.	4.30	4.30
1	2 1/2 x 3 1/2 in.	16 1/2 x 1 1/8	1 1/2	20 lbs.	5.35	5.35
2	3 x4 in.	19 x 1 1/8	1 1/2	24 lbs.	7.15	7.15
3	3 1/2 x 4 1/2 in.	21 1/2 x 1 1/8	1 1/2	30 lbs.	8.25	8.25
6	5 x6 in.	28 1/2 x 1 1/8	1 1/2	40 lbs.	13.50	13.50
7	5 1/2 x 6 1/2 in.	30 1/2 x 1 1/8	1 1/2	48 lbs.	15.00	15.00
8	6 x7 in.	32 1/2 x 1 1/8	1 1/2	60 lbs.	17.50	17.50

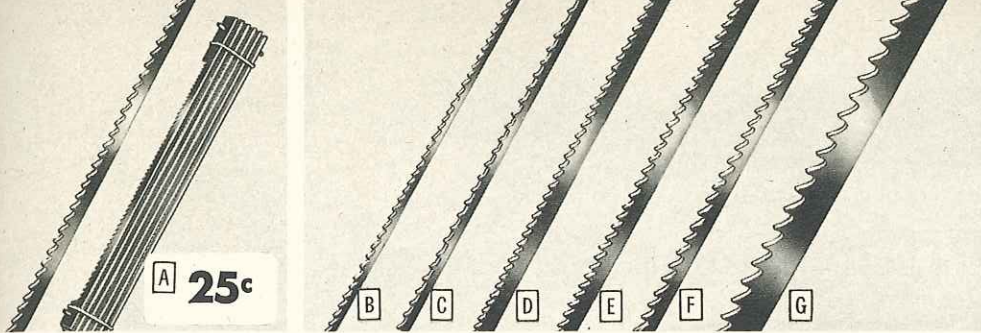

Jig, Fret, Coping Saw Blades

CRAFTSMAN. Expertly made of special alloy "Super-Tuff" steel, heat treated and hardened for long life and fast easy cutting. 6 and 8 1/2-in. plain end blades can be snapped off to fit machine taking shorter plain end blades. Saber tooth blades may be used for heavy cutting as well as saber work.

Use 9T2690, 9T2692, 9T2693, 9T2694 for wood, plywood, etc.; 9T2695, 9T2702 for wood and metal; 9T2709, 9T2700, 9T2701, 9T2704, 9T2705, 9T2706, 9T2707 and 9T2867 for wood or metal; 9T2710 for wood and plastic; 9T2866, 9T2869 and 9T2712 for wood and general use; 9T2703 for metal.

Catalog number	Thickness, inch	Width, inch	Blades in Pkg.	Type, End	Length, inches	Teeth per inch	Shpg. wt.	Per Pkg.
A 9 T 2690	.010	.040	6	Pin	5	18	1 oz.	25c
B 9 T 2692	.008	.035	8	Plain	6	22	1 oz.	25c
9 T 2693	.010	.045	8	Plain	6	18	1 oz.	25c
9 T 2694	.010	.055	8	Plain	6	16	1 oz.	25c
C 9 T 2695	.010	.070	8	Plain	6	14	1 oz.	25c
9 T 2703	.020	.070	6	Plain	6	32	1 oz.	25c
9 T 2702	.014	.078	6	Plain	6	16	1 oz.	25c
D 9 T 2709	.020	.110	6	Plain	6	20	1 oz.	25c
9 T 2710	.020	.110	6	Plain	6	7	1 oz.	25c
9 T 2700	.020	.110	6	Plain	6	10	1 oz.	25c
E 9 T 2701	.020	.110	6	Plain	6	16	1 oz.	25c
9 T 2704	.020	.110	6	Pin	5	10	1 oz.	25c
9 T 2705	.020	.110	6	Pin	5	15	1 oz.	25c
F 9 T 2706	.020	.110	6	Plain	8 1/2	10	1 oz.	25c
9 T 2707	.020	.110	6	Plain	8 1/2	15	1 oz.	25c
G 9 T 2866	.028	.250	3	Saber	6	7	1 oz.	25c
9 T 2867	.028	.250	3	Saber	6	20	1 oz.	25c
9 T 2869	.028	.1875	3	Saber	6	10	1 oz.	25c
9 T 2712	.010	.040	6	Pin	2 1/2	18	1 oz.	25c

CRAFTSMAN
Band Saw Blades

Finest quality saw steel. Every blade properly set and filed for recommended use. Shipping weight each, 7 ounces. Please state width wanted.

Low as **89c**

9 T 2660—For wood. 56 1/2 in. long, 1/8 or 1/4-in. width. Each 89c

9 T 2336—For wood. Skip tooth. 58 in. long. 3/16, 1/4 or 3/8-in. width. \$1.00

9 T 2663—For wood. Skip tooth. 62 in. long. 3/16, 1/4 or 3/8-in. width. \$1.00

9 T 2665—For wood. 63 in. long. 3/8, 1/2 or 3/4-in. width. \$1.00

9 T 2657—For wood. 78 in. long. 3/8, 1/2, 3/4 or 1/2-in. width. \$1.00

9 T 2623—For wood. 80 in. long; 3/8, 1/2, 3/4 or 1/2-in. width. \$1.00

9 T 2668—For brass and non-ferrous metal. 78 in. long; 1/4-in. width. \$1.08

9 T 2624—For brass and non-ferrous metal. 80-in. long; 1/4-in. width. \$1.08

9 T 2625—For steel 80 inches long; 1/4-inch width. \$1.55

Special length Band Saw Blades

9 T 2669F—Not brazed. Blades brazed for 40c each, in addition to prices below. State length and width wanted and if you want blades brazed. Shipped from factory in Chicago.

Width	Shpg. wt.	Per foot
3/8 inch	1 ounce	12c
3/8 inch	1 ounce	12c
3/8 inch	1 ounce	12c
3/8 inch	1 ounce	13c
3/8 inch	1 ounce	15c
3/8 inch	1 ounce	17c
3/8 inch	2 ounces	19c
1/2 inch	2 ounces	20c
1 1/2 inches	3 ounces	26c
1 1/2 inches	3 ounces	32c

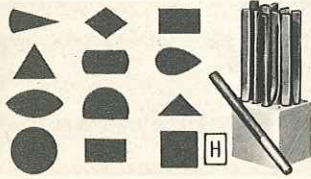

Jig Saw File Set

H **CRAFTSMAN.** Handy set of 12 jig saw files. Fit all standard makes of jig saws. Help eliminate tedious hand filing on metal or wood patterns, dies, scrollwork, etc. Files are 3 3/4 inches long with 1/2-inch round shanks. Swiss pattern, size 00, sharp, deep cut teeth.

Jig saw file set includes 3 pillar files, 1 three-square file, 1 square file, 1 round file, 1 crocheted file, 1 quarter-round file, 1 triangular file, 1 diamond file, 1 knife file and 1 round back file. Complete set of 12 in convenient wood box. Shipping weight 12 ounces.

9 T 6778 \$7.15

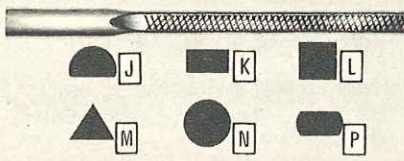

Special Jig Saw Files

Expertly made from special steel, heat treated, tempered and hardened. The strong, sharp, deep cut teeth stay sharp and wear long. Using these files eliminates that tedious hand filing. Have 1/4-inch square shanks.

- J** 9 T 2742—Half Round File. Shpg. wt. 1 oz. Each 59c
- K** 9 T 2740—Pillar File. Shpg. wt. 1 oz. Each 59c
- L** 9 T 2741—Square File. Shpg. wt. 1 oz. Each 59c
- M** 9 T 2737—3-Square File. Shpg. wt. 1 oz. Each 59c
- N** 9 T 2738—Round File. Shpg. wt. 1 oz. Each 59c
- P** 9 T 2739—Crochet File. Shpg. wt. 1 oz. Each 59c

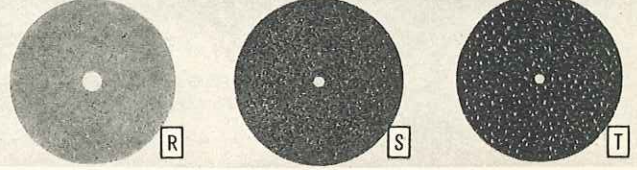

Rubber-bonded Cut-off Wheels

R Cuts metal bars, tubing, pipe, plastic, glass, tile, etc.—fast! Aluminum oxide abrasive. Maximum RPM, 6,000. Use on polishing heads, grinders, bench saws, etc. Use with coolant. 8-in. diam. by 3/32 in. thick. For 1/2, 3/8 or 3/4-in. shaft. State shaft diameter.

9 T 6470—Shpg. wt. 1 lb. Each \$1.29

S New Resinoid-bonded Cut-off Wheels. Superfast cutting of stone, brick, concrete, tile, porcelain, etc., as well as metals. Use on polishing heads, grinders, bench or electric hand saws. Maximum RPM, 6,000. 8-in. diam., 3/32 in. thick. For 1/2, 3/8 or 3/4-in. shaft. Shipping weight 1 lb. State shaft diameter.

9 T 6448—For steel sheets or tubing, etc. (aluminum oxide) Each \$1.39

9 T 6449—For tile, porcelain, etc. (silicon carbide) Each \$1.69

9 T 6455—For cast iron, brick, concrete (silicon carbide) \$1.69

New Bayflex Abrasive Wheels

T Extra safe! Here is the safest all purpose grinding wheel made! It's cotton felted, aluminum oxide impregnated and resinoid bonded. Will cut wood or metal; on sides or face. Cuts fast and wears long. Use it to replace back saw, file, sharpening wheel or circular saw. Use on grinder, bench saw or any arbor. Have 1-in. hole. Bushings furnished for smaller shafts.

9 T 6428—State diameter, grit and hole size.

Diam.	Thickness	R.P.M.*	Grit	Shpg. wt.	Each
6 in.	1/8 in.	10,000	120	8 oz.	\$1.43
6 in.	3/16 in.	10,000	80	12 oz.	1.75
6 in.	1/4 in.	10,000	24	1 lb.	2.10
7 in.	1/8 in.	8,500	120	12 oz.	1.85
7 in.	3/16 in.	8,500	80	1 lb.	2.25
7 in.	1/4 in.	8,500	24	1 lb. 8 oz.	2.69
8 in.	1/8 in.	7,500	120	1 lb.	2.29
8 in.	3/16 in.	7,500	80	1 lb. 4 oz.	2.85
8 in.	1/4 in.	7,500	24	1 lb. 8 oz.	3.39
10 in.	1/8 in.	6,000	80	2 lbs.	5.25
10 in.	3/4 in.	6,000	24	3 lbs.	8.45

Comparative Grit Chart for Abrasive Papers

Grade	Approx. Grit	Flint or Sandpaper	Garnet Paper	Emery Cloth	Alum. Oxide Cloth
Extra fine	150	2/0	4/0	2/0	3/0
Fine	120	1/0	3/0	1/0	2/0
Medium fine	100	1/2	2/0	0	2/0
Medium	80	1	0	1	0
Medium coarse	60	1 1/2	1/2	1/2	1/2
Coarse	40	2	1 1/2	1 1/2	1 1/2

Use Coarse to Medium Grit for fast removal of material; Fine to Medium-Fine Grit for semi-finishing; Extra-Fine Grit for high finishing and polishing.

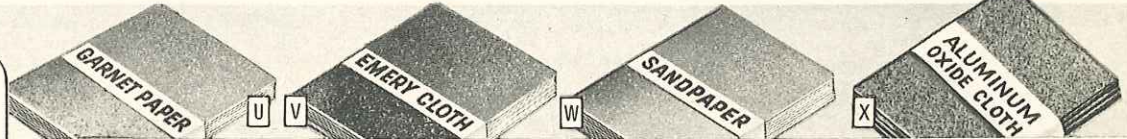

Garnet Paper

U Outlasts sandpaper. 9x11 in. 9 T 6795—State grit and size package

Grit	Shpg. wt. 24	Each	24 for
4/0 Extra fine	1 lb.	5c.	\$1.10
3/0 Fine	1 lb. 1 oz.	5c.	1.10
2/0 Medium fine	1 lb. 4 oz.	5c.	1.10
0 Medium	1 lb. 8 oz.	6c.	1.20
1/2 Med. coarse	1 lb. 13 oz.	7c.	1.45
1 1/2 Coarse	2 lbs. 2 oz.	9c.	1.85

Emery Cloth

V Package of 6 sheets, assorted. 9 T 6799—4 3/4x5 1/4 in. Wt. 3 oz. 9c
9 T 6798—Three 9x11-in. sheets, 2/0, 1/2 or 1 grit. State grit. Shpg. wt. 6 oz. 19c

Assorted Grit Sandpaper

W Handy package of 20 sheets; size 4 3/8x5 1/4 inches. 9 T 6794—Shipping wt. 6 oz. 9c

Packages of Sandpaper, 2, 3, 4 and 24-sheet packages. We do not break packages. Size of sheets 8 3/4x10 1/2 inches. 9 T 6793—State grit and size package

Grit	Shpg. wt. 24	24 for
00 Extra fine	1 lb.	4 for 5c
0 Fine	1 lb. 1 oz.	3 for 5c
1/2 Medium fine	1 lb. 4 oz.	3 for 5c
1 Medium	1 lb. 8 oz.	2 for 5c
1 1/2 Med. Coarse	1 lb. 13 oz.	2 for 5c
2 Coarse	2 lbs. 2 oz.	2 for 5c

Aluminum Oxide Cloth

X Sharper than garnet, and the toughest of all grains used in making coated abrasives. Ideal for metals, hardwood, plastics, etc. Size of sheets 9x11 in. Shipping wt. of three; 6 oz. 9 T 6789—Please state grit and size of package.

Grit	3 for	24 for
3/0 Fine	43c	\$3.25
2/0 Medium Fine	43c	3.25
0 Medium	39c	3.50
1/2 Medium Coarse	39c	3.50

Buy on Sears Easy Terms . . . see inside back cover for full details.

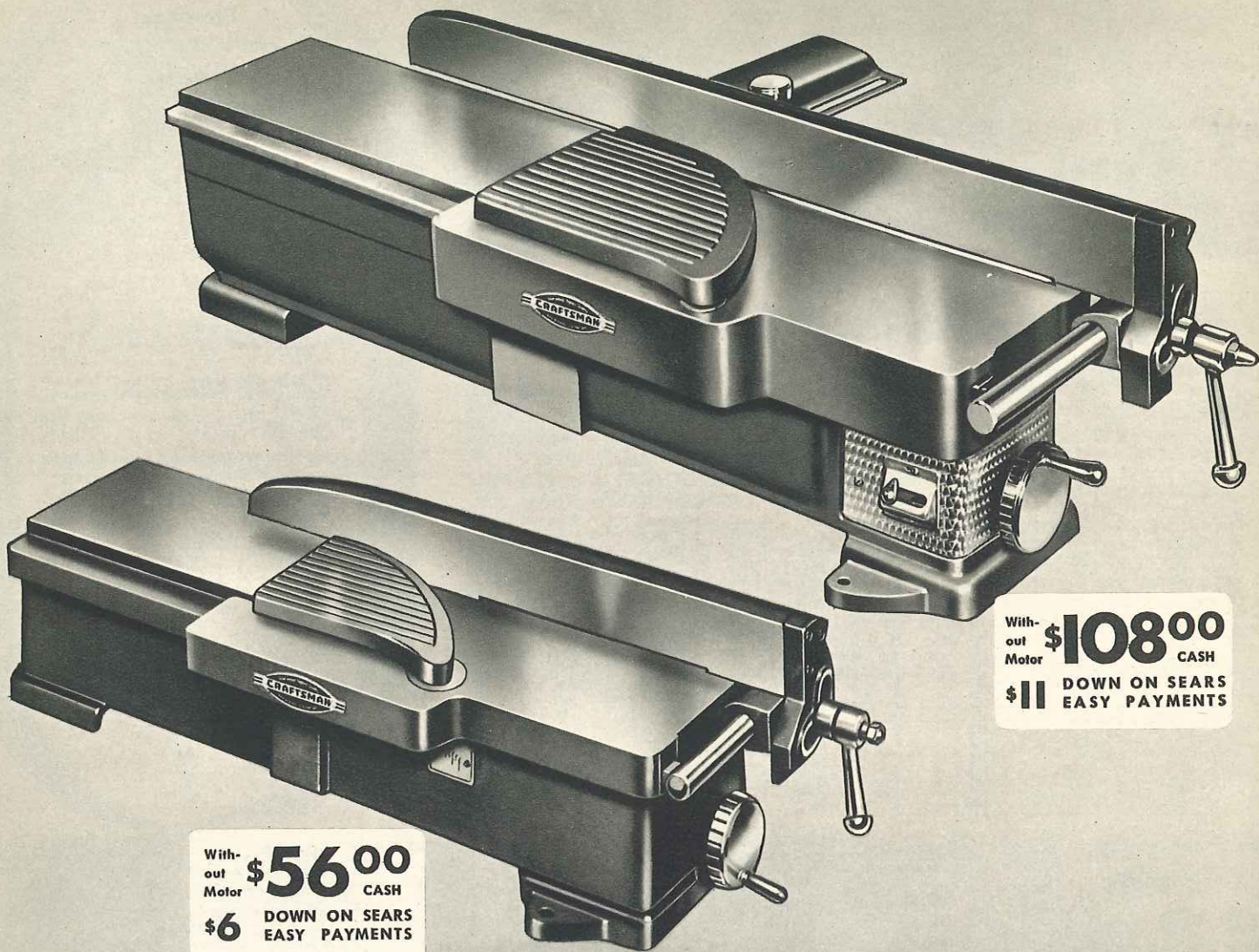

With-
out
Motor **\$108⁰⁰** CASH
\$11 DOWN ON SEARS
EASY PAYMENTS

With-
out
Motor **\$56⁰⁰** CASH
\$6 DOWN ON SEARS
EASY PAYMENTS

CRAFTSMAN Jointer-Planers . . . accurate and safe

CRAFTSMAN "80" bronze bearing type

The ideal jointer-planer for small woodworking shops, school shops and home workshops. The three high speed tool steel knives in the 4 3/8-inch cutter head are securely locked in. Retain sharp, easy-cutting qualities.

Front and rear table are precision ground cast iron and operate on accurately machined ways to insure perfect alignment. 19 1/8-inch fence tilts 45 degrees either way . . . locks in position. Rugged one-piece cast iron base, with three-point mounting, eliminates twist or strain, gives rigid support.

Quick-acting guard gives positive protection . . . readily removable for making rabbeting cuts. Accurate gauge indicates depth of cut and angle of tilt with rip fence. Two oilite bronze bearings . . . easily filled oil reservoirs.

SPECIFICATIONS:

- Width of cut 4 3/8 inches
- Depth of cut 3/8 inch
- Rabbet depth 3/8 inch
- Bearings 2—oilite bronze
- Cutter knives 3 high speed tool steel, 4 3/8 x 1 1/8 x 1/8 inches
- Length of front table 11 3/8 x 6 3/8 inches
- Length of rear table 11 1/8 x 6 3/8 inches
- Length of fence 19 1/8 inches
- Spindle diameter 3/8 inch
- Recommended speed 4500 R.P.M.
- Motor recommended, minimum 1/2 H.P. 1750 R.P.M.
- Machine pulley (included) 2 inch single "V" groove
- Motor pulley (not included) 5 inch single "V" groove
- Mounting dimensions 7 3/4 x 21 3/4 inches
- Overall dimensions: Height 8 inches; width 9 3/4 inches; length 29 1/8 inches
- 99 TM 2322—CRAFTSMAN Jointer without motor. Shpg. wt. 65 lbs. **\$56.00**
- 99 TM 2374—CRAFTSMAN Jointer with 1/2 H.P. 1750 R.P.M. ball bearing split phase motor for 110-120-volt 60 cycle A.C. Shipping weight 95 lbs. **\$74.50**
- 4 3/8-inch Jointer Replacement Knives. High speed tool steel blades that are ground to a keen edge. Finest quality. Set of three for above jointers or for CRAFTSMAN Jointer-Planers numbers 2287 and 2290.
- 9 TM 2291—Shipping weight 7 ounces Set **\$3.45**

CRAFTSMAN "100" ball bearing type

This heavy duty jointer-planer gives you greater accuracy, smoothness of operation and safety than ordinary jointers. The 6-inch solid steel cutterhead, with the 3 high speed tool steel knives, cuts cleanly and accurately.

Sturdy construction. Extra long precision ground cast iron table. Three-point suspension mounting of rear table aligns it perfectly with front table. Front table mounted on double set of widely spaced ways. One-piece base is rugged cast iron for rigid support. Three-point-of-contact mounting eliminates twist.

Quick-acting spring-loaded guard gives complete protection. It never needs to be removed while machine is running. Guard can be removed in one motion for rabbeting cuts. Belt and pulley fully enclosed by guard for safety. 31 1/16-inch fence tilts up to 45° in either direction . . . locks in place.

SPECIFICATIONS:

- Width of cut 6 1/8 inches
- Depth of cut 1/2 inch
- Rabbet depth 1/2 inch
- Bearings 2—precision ball
- Cutter knives 3 high speed tool steel, 6 1/8 x 1 1/8 x 1/8 inches
- Length of front table 16 3/16 x 7 7/8 inches
- Length of rear table 17 7/8 x 7 7/8 inches
- Length of fence 31 1/16 inches
- Spindle diameter 3/8 inch
- Recommended speed 4500 R.P.M.
- Motor recommended, minimum 1/2 H.P. 3450 R.P.M.
- Machine pulley (included) 2 inch single "V" groove
- Motor pulley (not included) 2 1/2 inch single "V" groove
- Mounting dimensions 8 5/8 x 32 1/8 inches
- Over-all dimensions: Height 11 3/4 inches; width 20 inches; length 42 1/2 inches
- 99 TM 2332—CRAFTSMAN Jointer without motor. Shpg. wt. 151 lbs. **\$108.00**
- 99 TM 2375—CRAFTSMAN Jointer with 1/2 H.P. 3450 R.P.M. ball bearing capacitor motor for 110-120-volt 60 cycle A.C. Shpg. wt. 187 lbs. **\$137.50**
- 6 1/8-inch Jointer Replacement Knives. Made of high speed tool steel; expertly ground. Set of three for above jointer and for thickness planer No. 2370.
- 9 T 2293—Shipping weight 9 ounces **\$4.15**

CRAFTSMAN
REG. U.S. PAT. OFF.

THE RIGHT WAY
TO SAY
**HARDWARE
AND TOOLS**

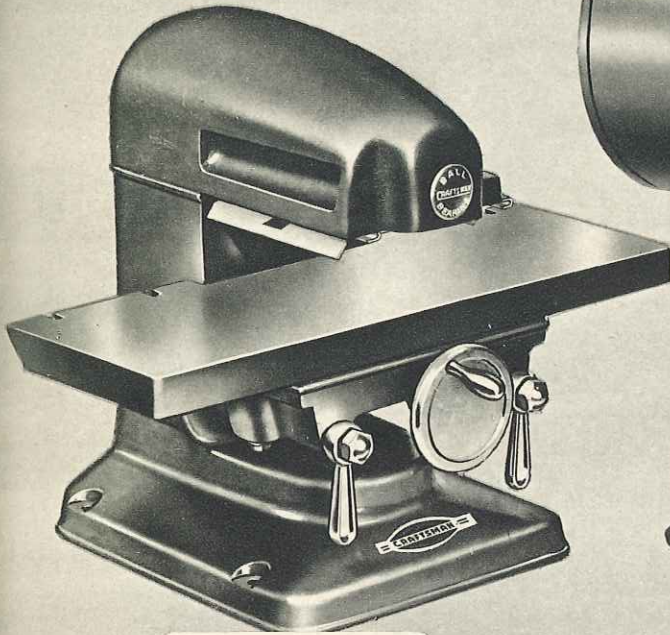

Without Motor **\$57⁰⁰** CASH
\$6 DOWN ON SEARS EASY PAYMENTS

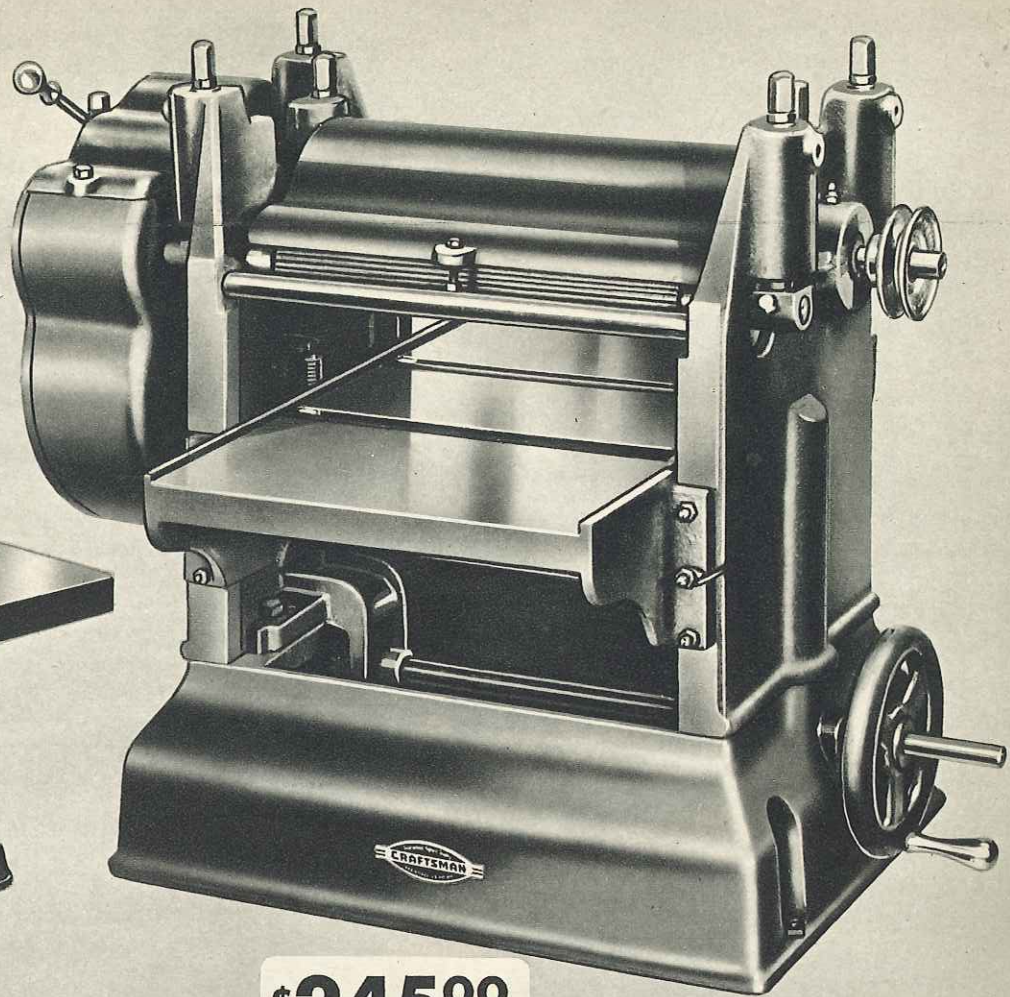

\$245⁰⁰ CASH
Without Motor
\$2450 DOWN . . ON EASY TERMS

CRAFTSMAN "100" Thickness Planers

CRAFTSMAN Hand Feed Thickness Planer

NOW! The CRAFTSMAN "100" thickness planer—the planer thousands of craftsmen have wanted to own. It's designed and priced low at Sears. With this thickness planer you can salvage old material . . . finish rough sawed lumber . . . reclaim marred or painted wood . . . make flat stock out of warped boards, etc.

Large capacity. With this planer you'll be able to plane material up to 6 inches wide and 2 inches thick . . . as small as 4 inches long and $\frac{1}{8}$ inch thick. The new open side design allows you to plane 12 inch boards. Depth of cut is adjusted by convenient handwheel. Accurate scale shows depth of cut.

Accurate operation. Safety type solid steel cutter head is fitted with 3 precision ground steel knives. Ideal on small jobs where accuracy is uppermost. Holds cut to within a few thousandths of an inch.

Rugged long-life construction. Heavily ribbed cast iron table and frame. Ways milled into one casting for greater accuracy. Simple and efficient hand feed construction. Chip breaker and pressure bar completely guard cutting head; hold lumber firmly on the table. Both are easily removed if necessary.

SPECIFICATIONS:

- Depth of cut, maximum $\frac{5}{32}$ inch
- Width of cut, maximum6 inches
- Table size $6\frac{5}{16} \times 19\frac{3}{16}$ inches
- Size of cutter head $2\frac{3}{8}$ inches diameter
- Knives three; size $6\frac{1}{2} \times 1\frac{1}{16} \times \frac{1}{8}$ inches
- Bearings 2 sets precision ball
- Machine pulley (included) 2 inch "V" groove
- Motor pulley (not included) $2\frac{1}{2}$ inch "V" groove
- Motor recommended, minimum $\frac{1}{2}$ H.P. 3450 R.P.M.
- Mounting dimensions 8x10 inches
- Over-all dimensions; Height $15\frac{1}{4}$ in.; width $15\frac{1}{4}$ in.; length $19\frac{3}{16}$ in.

- 99 TM 2370—Without motor. Shipping weight 83 pounds. **\$57.00**
- 99 TM 2371—With $\frac{1}{2}$ H.P. 3450 R.P.M. ball bearing capacitor motor for 110-120 volt 60 cycle A.C. Shpg. wt. 119 lbs. **\$86.50**
- 9 T 2293—Set of 3 extra knives for above planer. Shpg. wt. 9 oz. **\$4.15**

CRAFTSMAN Power Feed Thickness Planer

The new CRAFTSMAN "100" heavy duty thickness planer is THE planer you need for your work. It's rugged and sturdy to withstand big daily production work yet sensitive and accurate to do exceptionally fine planing. Extremely accurate cutting . . . holds cut to within a few thousandths of an inch . . . produced by balanced, extra large diameter cutter with 3 knives, and fast smooth power feed.

Extra large capacity. Now you can plane lumber up to 12 inches wide and 4 inches thick . . . pieces as short as 6 inches and as thin as $\frac{1}{16}$ inch. The maximum depth of single cut $\frac{5}{32}$ inch depending on kind of wood. Equipped with accurate depth of cut scale.

Solid, massive construction. Heavily ribbed table is fitted to massive one-piece cast iron frame by precision machined ways. Smooth ground table quickly and easily raised and lowered by convenient handwheel to adjust depth of cut.

Safety type cutter head, $3\frac{1}{2}$ inches in diameter, is machined from solid bar steel and fitted with 3 high speed knives. Chip breaker and pressure bar protect cutter head and feed rolls; hold lumber firmly to the bed to prevent chips from tearing the surface. Feed rolls; machined from solid steel, grip lumber firmly and feed at the rate of 17 lineal feet per minute.

SPECIFICATIONS:

- Depth of cut, maximum $\frac{5}{32}$ inch
- Width of cut, maximum 12 inches
- Table size 12x20 inches
- Size of cutter head $3\frac{1}{2}$ inches
- Knives three; size $12 \times \frac{1}{8} \times \frac{1}{8}$ inches
- Bearings 2 sets precision ball
- Power feed rate 17 lineal feet per minute
- Machine pulley (included) 3 inches
- Motor pulley (not included) $6\frac{1}{2}$ inches
- Motor recommended (variable) $\frac{3}{4}$ to 2 H.P.; 1750 R.P.M.
- Recommended cutter head speed 4200 R.P.M.
- Mounting dimensions $8\frac{3}{4} \times 18\frac{3}{4}$ inches
- Over-all dimensions: ht. 23 in.; width 33 in.; lgth. 20 in.; depth 20 in.

- 99 TM 2349—Without motor. Shipping weight 300 pounds. **\$245.00**

\$42.50
CASH
\$4.50 DOWN . . .
ON TERMS



With box and accessories

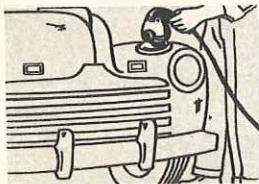

Really a work saver! Perfect for polishing your car, removing rust, and similar jobs



Flexible sanding discs are just the thing for sanding curved or irregular work surfaces



Works in any position. Use for resurfacing floors, woodwork, ceilings, furniture, etc.

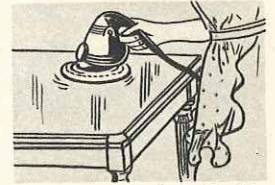

Takes the hard work out of polishing furniture, floors, linoleum, etc. Saves time in the home or shop

CRAFTSMAN Disc Sander, Buffer, Polisher

Will actually do the job 10 times faster than by hand

Painters, cabinet makers, metal workers, auto refinishers, hobby crafters and housewives . . . you'll want this CRAFTSMAN Disc Sander for your work. Everyone who does sanding or polishing will want it. It's ideal for work on autos, boats, furniture, floors, wood or metal . . . and for all types of general maintenance work. You'll actually be able to do your sanding, polishing and buffing jobs *10 times faster than by hand*. Produces a better job without all the hard work.

Easy to operate. Just think . . . No rubbing! No pressing! No more aching arms and backs! You'll be amazed at how easy this disc sander is to operate and how swiftly it does your work. Simply plug it in . . . snap the handy trigger switch . . . and go to work. The machine does the work for you almost like magic. All you do is guide it.

Lightweight. It weighs only 6 pounds. So light and well designed that it's as easy to handle as an ordinary flatiron. Women can use it to zip through those

ordinarily tiresome polishing tasks in the home.

Sturdy construction. Frame is made of strong die-cast aluminum alloy . . . makes this disc sander light and easy to operate yet withstands many long hours of steady use. Equipped with a heavy duty 110-120-volt General Electric Universal A.C.-D.C. motor with Formex insulation . . . assuring long motor life. The motor, mounted directly over disc, provides maximum power and perfect balance.

SPECIFICATIONS:

- Disc size, diameter 6 inches
- Over-all height, with disc 7 inches
- Bearings Precision ball
- Gears Helical spur
- Free speed of disc 1600 R.P.M.
- Switch Trigger type; Non-locking
- Motor G.E. Universal 110-120 volt, 25-60 cycle, A.C.-D.C.
- Length of cord 10 feet

Handy knob and switch. Convenient, easy to control trigger switch is located on hand-fitting handle. Switch is non-locking. Large plastic knob for two hand control can be mounted on either side.

Accessories included. Comes complete with 10-ft. 3-wire rubber covered cord and plug, 6-inch flexible rubber sanding disc, 7-inch lamb's wool buffing bonnet, 6 assorted sanding discs, socket wrench for attaching discs and steel case to hold sander and accessories. Sander may be used on wood, metal, plastic, concrete, stone, wallboard etc. either flat or curved surfaces. Shipping weight 15 pounds.
99 T 02561—CRAFTSMAN Disc Sander \$42.50

Sanding discs for above sander. Made of silicon carbide abrasive. Choice of four grits; 00 (extra fine), 0 (fine), 1 (medium) or 2 (coarse). Package of 6 of any one grit. Diameter of discs 6 inches.
9 T 2562—State grit wanted. Shpg. wt. 7 oz. 39¢



CRAFTSMAN
REG. U. S. PAT. OFF.

THE RIGHT WAY
TO SAY

**HARDWARE
AND TOOLS**

Without motor **\$46⁰⁰** CASH
\$5 DOWN ON SEARS EASY PAYMENTS

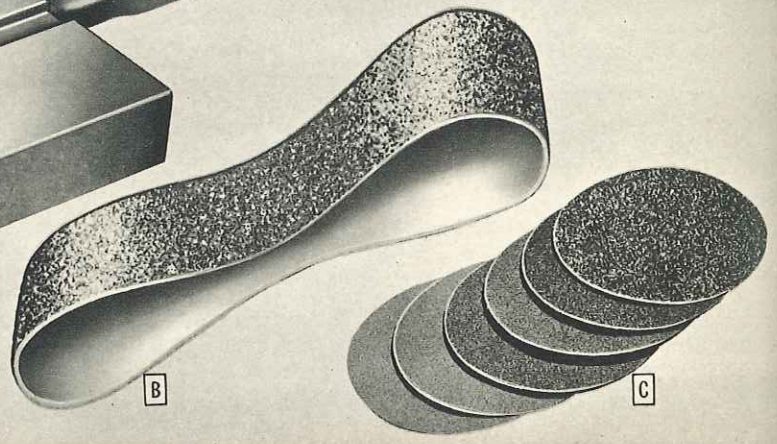
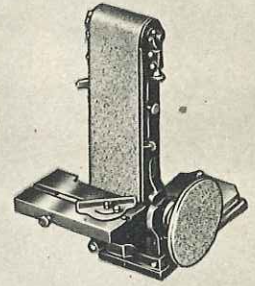

CRAFTSMAN "100" Belt and Disc Sander

6 by 48-inch Belt Sander and 9-inch Disc Sander combined

- Belt Sander adjustable to horizontal, vertical or any intermediate angle 0 to 90 degrees
- Quick-change device releases belt tension for rapid belt changes
- Oilite bronze bearings filter oil and keep out dust and dirt . . . oil well completely around each bearing

Here is one of the most versatile and useful CRAFTSMAN Power Tools. It's a "must" for every well equipped woodworking shop because it takes the hard tedious work out of sanding. Both flat and curved surfaces can be sanded with it . . . with the 9-inch disc you can sand end grain and small work; with the end drums, curved and irregular work and with the 6-inch belt all types of flat work.

Large adjustable sanding disc table. 6½x12 inch table can be tilted to any angle up to 45 degrees. This enables you to do extremely accurate sanding of mitered edges. You can use the disc sander and table on either right or left side of sander or at the end. Both table and sanding disc can be removed to enable you to sand extra long work on the belt. The disc sander is ideal for finishing work which cannot be reached by belt sander alone.

Position of belt sander easily adjusted. You can use the 6-inch belt sander in vertical position (as shown in the small illustration above) with sanding table mounted at end of machine, in horizontal position or at any intermediate angle. This feature permits you to mount the sander at the end of your work bench for greater convenience.

Quick-change belt release. Rapid change from belt of one grit to another is possible. Lever releases belt tension. Rubber-covered belt rollers can be used as drum sanders.

Rugged, long-life construction. Equipped with large self-lubricating bronze bearings. Extra long bronze bearings on main arbor insure long life and smooth operation. Table and frame made of durable cast iron, gray enamel finish.

SPECIFICATIONS:

- Width of belt 6 inches
- Length of belt 48 5/16 inches
- Sanding Belt table 6½x17 9/16 in.
- Sanding disc table 6½x12 in.
- Diameter of disc sander 9 inches
- Bearings 4 oilite bronze
- Drum diameter 3 inches
- Machine pulley (included) 3 inch
- Motor pulley (not included) 2½ inch
- Motor recommended, min. ¼ H.P. 1750 R.P.M.
- Mounting dimensions 7x15 3/16 inches
- Overall dimensions: Height 11¼ inches; width 20½ inches; length 28¾ inches.

Comes complete with miter gauge, adjustable stop guard, 9-inch abrasive disc 6x48-inch sanding belt and 3-inch machine pulley.

A CRAFTSMAN Belt and Disc Sander without motor, motor pulley or V belt.
9 TM 2235—Shipping weight 65 pounds. **\$46.00**

CRAFTSMAN Belt and Disc Sander with ¼ H.P. 1750 R.P.M. split phase ball bearing 110-120 volt A.C. motor. Without motor pulley or V belt.
9 TM 2233—Shipping weight 100 pounds. **\$73.50**

B Replacement Sanding Belt for Above Sander. Aluminum oxide abrasive on durable cloth backing. Made in one continuous piece 48 inches long and 6 inches wide. For use on wood or metal. Your choice of fine, medium or coarse grit. **State grit wanted.**
9 T 2167—Shipping weight 8 oz. Each **\$1.15**

C Replacement Sanding Discs for Above Sander. Aluminum oxide on paper backing. 9 inches in diameter. For use on wood or metal. Come in package of six: two each of fine, medium and coarse grit.
9 T 2155—Shipping weight 8 oz. 6 in pkg. **75c**

Buy on Sears Easy Terms . . . see inside back cover



\$23.95
CASH
\$2.50 DOWN... ON
EASY TERMS

CRAFTSMAN Rotary Electric Tool

REG. U. S. PAT. OFF.

Hundreds of uses in every industrial or home workshop

Expert craftsmen, hobbyists—even novices will get a real thrill from using this CRAFTSMAN Rotary Electric Tool. You'll be able to turn out fine work quickly and easily. Excellent for toolroom and light production work. Use this tool for grinding, drilling, routing, carving, sawing, polishing, sanding, cutting and engraving on wood, metal, glass, leather, plastic, etc.

Lightweight and convenient. Weighs 1 3/4 pounds less cord. Pistol grip handle is readily removable. Finger rest over chuck. Balances in hand for comfortable use. Handy ripping guide and depth of cut gauge. Powerful construction. Accurate chuck with collet

inserts assures solid locking of accessories. Fan-cooled motor has balanced armature; built-up commutator. Built-in condenser reduces radio interference. Approved by Underwriters' Laboratories, Inc.

SPECIFICATIONS:

- Over-all length..... 7 inches
- Extreme diameter..... 2 inches
- Barrel diameter..... 1 1/4 inches
- Bearings..... 1 bronze and 1 ball bearing
- Chuck capacity..... 3/8 and 3/16 inches
- Speed..... 18,000 R.P.M.
- Insulation..... Tested at 1000 volts

- Motor..... Universal, 110-120 volt 25-60 cycle, A.C. or D.C.
- Brushes..... Large size, replaceable from outside
- Switch..... Special design; positive break

The leader for completeness. Comes complete with 35 accessories: one each of the accessories shown below plus extra mandrels, sanding sleeves and abrasive discs, two chuck wrenches, collet chuck, socket wrench, emery wheel dresser, set of replacement brushes, 5 1/2-foot rubber covered cord and plug. With sturdy, lined, simulated leather covered workshop box. 9 T 2652—Shipping weight 3 lbs. 4 oz..... **\$23.95**

Accessories for CRAFTSMAN Rotary Electric Tool

REG. U. S. PAT. OFF.



Cutters: For rapid and efficient work on soft metals such as aluminum, tin, lead, bronze, etc. Ideal for making delicate designs in soft or hard wood.

- A** 9 T 2670—Oblong cutter. Diameter 3/16 inch; 3/8 inch long..... 59c
- B** 9 T 2636—Ball cutter. Diameter 11/64 inch..... 59c
- C** 9 T 2671—Ball cutter. Diameter 1/4 inch..... 59c

- D** 9 T 2672—Cone cutter. Diameter 7/32 inch..... 59c
- E** 9 T 2673—Oval cutter. Diameter 7/32 inch..... 59c
- F** 9 T 2674—Flat cutter. Diameter 3/32 inch; length 3/16 inch..... 65c
- G** 9 T 2837—Pointed cutter. Diameter 7/64 inch..... 59c
- H** 9 T 2656—Saw and Mandrel. Diameter 3/8 inch. .032 inch thick..... 69c

- J** 9 T 2689—Saw blade without mandrel. Diameter 3/4 inch..... 39c
- K** 9 T 2684—High speed drill. Diameter 1/16 inch..... 35c
- L** 9 T 2685—High speed drill. Diameter 3/32 inch..... 35c
- M** 9 T 2686—High speed drill. Diameter 1/8 inch..... 35c

Brushes. Ideal for reaching hard-to-get-at places, polishing, cleaning out cavities, and many other jobs. Expertly designed and made

- N** 9 T 2679—Disc type bristle brush. 3/4 inch diameter..... 15c
- P** 9 T 2680—Cup type bristle brush. 1/2 inch diameter..... 15c
- R** 9 T 2681—Mounted portable polishing brush. 3/16 inch diameter..... 15c

NOTE: The shipping weight for each of the above accessories for the CRAFTSMAN Rotary Electric Tool is 2 ounces

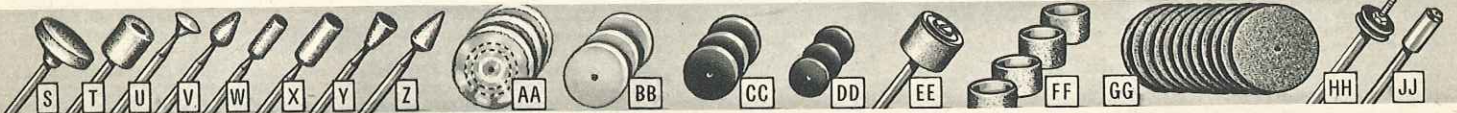

Mounted Emery Wheels. Ideal for shaping or for giving a fine, smooth finish to metal. Choice of sizes and shapes as shown for wide variety of jobs.

- S** 9 T 2653—1-inch diameter; 1/8-inch thick..... 35c
- T** 9 T 2654—1/2-inch diameter; 1/8-inch long..... 35c
- U** 9 T 2675—3/16 inch diameter..... 29c
- V** 9 T 2676—1/4-inch taper emery wheel..... 29c

- W** 9 T 2677—3/16-inch diameter; 1/2-inch long..... 29c
 - X** 9 T 2678—1/4-inch diameter; 1/2-inch long..... 29c
 - Y** 9 T 2831—1/4-inch diameter; 1/4-inch long..... 29c
 - Z** 9 T 2832—1/4-inch diameter; 5/8-inch long..... 29c
- Polishing Wheels; Abrasive Drums, Discs.**
- AA** 9 T 2951—Set of 3 buffing wheels. 1 1/4 inch diameter..... 35c

- BB** 9 T 2977—Set of three felt buffers. 1-inch diameter..... 35c
- CC** 9 T 2952—Set of three rubber-bonded polishing wheels. 7/8-inch diameter..... 29c
- DD** 9 T 2953—Set of three knife-edge rubber taper wheels. 5/8-inch diameter..... 29c
- EE** 9 T 2696—Mounted sanding drum assembly with sanding sleeve. 3/4-inch diameter; 1/2-inch width..... 39c

- FF** 9 T 2699—Set of four replacement sanding sleeves for above sanding drum assembly..... 25c
- GG** 9 T 2691—Set of 12 silicon carbide discs. 1 in. diam.; 1/32 in. thick. Mounting hole size 1/16 in. diam..... 29c
- HH** 9 T 2666—Nut and collar type..... 17c
- JJ** 9 T 2667—Screw-in-end type..... 17c

NOTE: Shipping weight of above CRAFTSMAN Rotary Tool accessories is 2 oz. each.

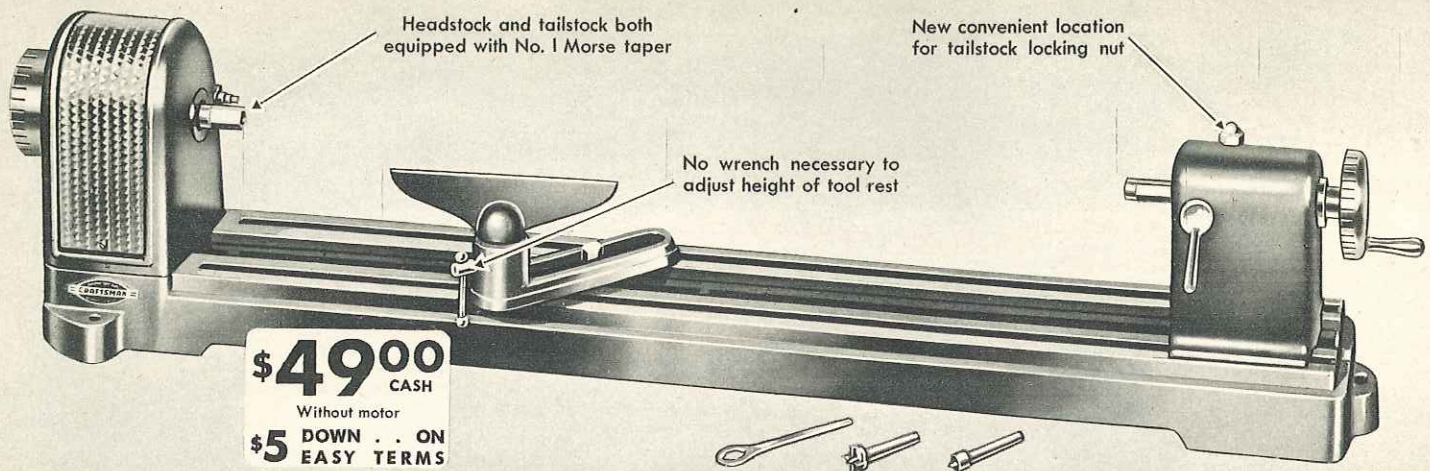

CRAFTSMAN "80" Wood Turning Lathe

A superb new heavy duty design . . . Only \$5 down on Easy Terms

9-inch swing . . . 30 inches between centers . . . 46 $\frac{3}{4}$ -inch bed. By far our finest wood-turning lathe. A big production type lathe—with extra heavy duty construction throughout. A perfect tool for the master craftsman. Because of its excellence in every detail, it is sure to gain an important place in professional woodworking and pattern shops all over America.

Extra heavy cast semi-steel construction reduces vibration. Even under heavy cuts or high speeds this lathe operates with exceptional smoothness and accuracy. Bed is sturdy, rigid and well braced. Three-point mounting helps eliminate twist and strain. All parts are accurately machined.

Two oiled self-lubricating bronze bearings and one ball thrust bearing in headstock. Provide almost limitless service. Oil well around each bearing. Protected against grit and dirt. Oil actually filters through bronze. Assures longer life—greater accuracy in operation. Ball thrust bearing absorbs end thrust.

No. 1 Morse taper centers in both headstock and tailstock. Easy to use with work arbor, drill chuck, etc. Removable cover on outboard end of $\frac{3}{4}$ -inch headstock spindle permits outboard turning of larger diameter work without reversing motor. Has indexing pin for use in fluting. May be driven from rear or below.

Comes complete with tool rest, spur and cup centers, wrench (same wrench is used for both tool-rest slide and tailstock), 4-inch 4-step motor pulley. (V-belt not included.) Attractive rust-resisting gray enamel finish. Chromium plated hand wheels and headstock spindle cover.

SPECIFICATIONS:

- Spindle $\frac{3}{4}$ -inch straight unthreaded; No. 1 Morse female taper
- Spindle speeds Four: 875, 1350, 2250 and 3450 R.P.M.
- Tailstock taper No. 1 Morse, female
- Tailstock ram travel 2 $\frac{3}{4}$ inches
- Machine pulley (supplied) 4-in. 4-step V type cone
- Motor pulley recommended (not supplied) 4-in. 4-step V type cone
- Motor recommended (minimum) $\frac{1}{8}$ H.P. 1750 R.P.M.
- Mounting dimensions (hole centers) 7 $\frac{1}{16}$ x43 $\frac{1}{2}$ in.
- Over-all dimensions Height 10 $\frac{1}{4}$ in.; width 8 $\frac{3}{4}$ in.; length 50 $\frac{1}{4}$ in.
- 99 TM 2318—Without motor. Shpg. wt. 78 lbs. \$49.00
- 99 TM 2372—With $\frac{1}{8}$ H. P. split phase 1750 R.P.M. 110-120-volt 60-cycle A.C. ball bearing motor. Shpg. wt. 108 pounds \$67.50

CENTERS

For Centers to fit the CRAFTSMAN Lathe above see page 33

CHUCKS

For Chucks to fit the CRAFTSMAN Lathe above see page 33

ARBORS

For Arbors to fit the CRAFTSMAN Lathe above see page 33

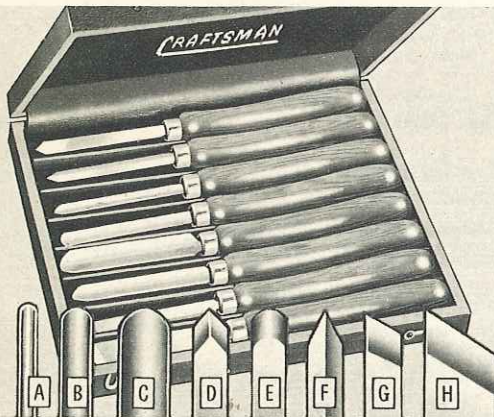

CRAFTSMAN Turning Chisels

In these fine chisels, you get genuine CRAFTSMAN quality at moderate prices. All have brightly polished 4-inch steel blades, carefully tempered to take and hold a keen edge for fast, clean cutting. Expertly ground. 8-inch handles of smoothly finished hardwood, securely fastened to blades. Heavy ferrule. Average over-all length 13 inches. Shipping weight each, 13 ounces.

- | | |
|--|--------|
| (A) 9 T 2850—Gauge, $\frac{1}{4}$ -inch wide | \$1.19 |
| (B) 9 T 2851—Gauge, $\frac{1}{2}$ -inch wide | 1.19 |
| (C) 9 T 2852—Gauge, $\frac{3}{4}$ -inch wide | 1.19 |
| (D) 9 T 2854—Spear Point Chisel, $\frac{1}{2}$ -in. wide | .79 |
| (E) 9 T 2856—Round Nose Chisel, $\frac{1}{2}$ -in. wide | .79 |
| (F) 9 T 2858—Parting Tool, $\frac{1}{2}$ in. wide | .98 |
| (G) 9 T 2862—Skew Chisel, $\frac{1}{2}$ -in. wide | .79 |
| (H) 9 T 2863—Skew Chisel, 1-inch wide | .89 |

9 T 2853—Complete set of 8 chisels listed above, in sturdy wood box covered with attractive artificial leather. Shipping weight 8 pounds 10 ounces. **\$9.95**

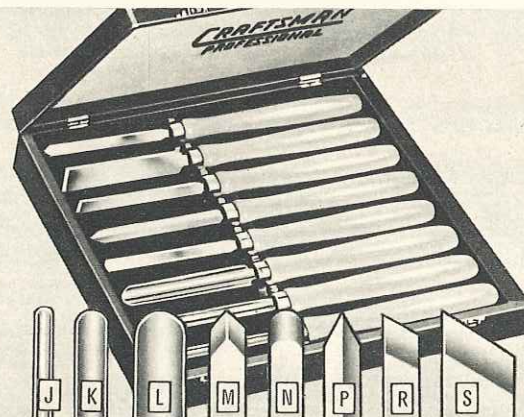

CRAFTSMAN heavy duty Chisels

The finest wood-turning chisels we have ever sold. Real professional quality. Forged "Super-Tuff" steel blades, about 6 in. long, heat treated to take and hold a super keen edge. Expertly ground. Blades are highly polished and beautifully finished. 10-inch maple handles have lustrous natural finish. Average length 16 $\frac{1}{4}$ inches. Shipping weight each, 1 pound 2 ounces.

- | | |
|---|--------|
| (J) 9 T 2877—Gouge, $\frac{1}{4}$ -inch wide | \$1.85 |
| (K) 9 T 2878—Gouge, $\frac{1}{2}$ -inch wide | 1.85 |
| (L) 9 T 2879—Gouge, $\frac{3}{4}$ -inch wide | 1.85 |
| (M) 9 T 2890—Spear Point Chisel, $\frac{1}{2}$ -inch wide | 1.25 |
| (N) 9 T 2891—Round Nose Chisel, $\frac{1}{2}$ -inch wide | 1.25 |
| (P) 9 T 2893—Parting Tool, $\frac{1}{2}$ -inch wide | 1.35 |
| (R) 9 T 2894—Skew Chisel, $\frac{1}{2}$ -inch wide | 1.25 |
| (S) 9 T 2895—Skew Chisel, 1-inch wide | 1.29 |

9 T 2898—Set of 8 professional chisels listed above, in heavy wood box covered with attractive artificial leather. Shipping weight 11 lbs. **\$13.50**

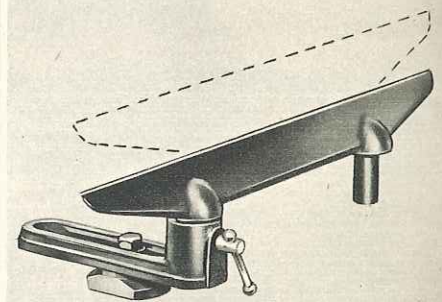

Long Tool Rest

May be used on the Craftsman Lathe 99 TM 2318 above. **\$539**

This extra long tool rest is 20 in. long. Especially useful when turning long pieces, such as table legs, lamp standards, etc. High quality cast semi-steel construction. Mounts rigidly on the lathe. Height easily adjustable.

9 T 2316—Shpg. wt. 10 lbs. \$5.39

EASY TERMS

It's easy to buy the power tools, accessories you need in one order . . . use Sears Easy Terms. See inside back cover.



CRAFTSMAN
REG. U.S. PAT. OFF.

THE RIGHT WAY
TO SAY

**HARDWARE
AND TOOLS**

CRAFTSMAN "40" Lathe . . new design, features

Only \$3 down will put this fine Wood Turning Lathe in your shop

8-inch swing . . . 24 inches between centers . . . 36 $\frac{3}{4}$ -inch bed. Famous CRAFTSMAN quality is built into every part of this rugged, well made lathe. Modern in every way . . . with many important post-war improvements in design and construction. We believe you will find it impossible to buy another lathe in this price range that matches this CRAFTSMAN Lathe for quality, features, performance and capacity. It's a "must" in any well equipped work shop.

Heavy cast semi-steel construction for smooth, accurate operation. Entire bed is made in one piece, ribbed and reinforced to reduce vibration to a minimum. All parts are accurately machined. 3-point mounting helps eliminate twist and strain. Tailstock easily and quickly adjusted.

Two oilite self-lubricating bronze bearings and one ball thrust bearing in headstock. Oil well surrounds each bearing. This close, tight seal keeps spindle journals accurate—protects them against dirt and grit. Oil actually filters through bronze. Assures longer life and greater accuracy in operation. Ball thrust bearing absorbs spindle thrust to give smooth, accurate operation.

$\frac{3}{8}$ -inch straight unthreaded spindles in headstock and tailstock. Removable cover on outboard end of spindle makes it easy to turn large diameter work without

reversing the motor. May be driven from the rear or below. Comes complete with tool rest, spur and cup centers, wrench (for tool rest slide, tool rest, and tailstock lock) and 3-inch 3-step pulley. (V-belt not included.) Attractive rust-resisting gray enamel finish; handles and headstock spindle cover are cadmium plated.

SPECIFICATIONS:

- Spindle $\frac{3}{8}$ -inch straight unthreaded
 - Spindle speeds Three: 1025, 1750 and 2985 R.P.M.
 - Tailstock ram travel 1 $\frac{1}{2}$ inches
 - Machine pulley (included) 3-inch 3-step V-type cone
 - Motor pulley recommended (not included) 3-inch 3-step V-type cone
 - Motor recommended (minimum) $\frac{1}{2}$ H.P. 1750 R.P.M.
 - Mounting dimensions (hole centers) 3 $\frac{3}{4}$ x 6 in.
 - Over-all dimensions Height 8 $\frac{3}{8}$ in.; width 7 in.; length 40 in.
- 99 T 02160—Without motor. Shipping weight 54 pounds. \$31.50
 99 TM 2162—With $\frac{1}{2}$ H.P. split phase 110–120-volt 60-cycle A.C. 1750 R.P.M. ball bearing motor. Shipping weight 84 pounds. \$50.00

CENTERS

For Centers to fit the CRAFTSMAN Wood Turning Lathe above—turn to page 33

CHUCKS

For Chucks to fit the CRAFTSMAN Wood Turning Lathe above—turn to page 33

ARBORS

For Arbors to fit the CRAFTSMAN Wood Turning Lathe above—turn to page 33

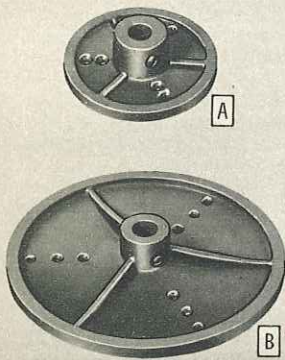

Face Plates

Make your lathe much more useful. High quality cast iron construction. Complete with setscrew. **\$220**

A For 99 T 02160 lathe above or any other lathe with $\frac{3}{8}$ -inch straight unthreaded spindle. 4-in. diam. 9 T 2320

9 T 2320—4-inch diameter. Shpg. wt. 1 lb. 5 oz. \$2.20
 9 T 2081—6-inch diameter. Shpg. wt. 1 lb. 14 oz. 2.55

B For 99 TM 2318 lathe on opposite page or any lathe with $\frac{3}{8}$ -inch straight unthreaded spindle.

9 T 2324—4-inch diameter. Shpg. wt. 2 lbs. \$2.20
 9 T 2325—8-inch diameter Shpg. wt. 2 lbs. 8 oz. 3.90

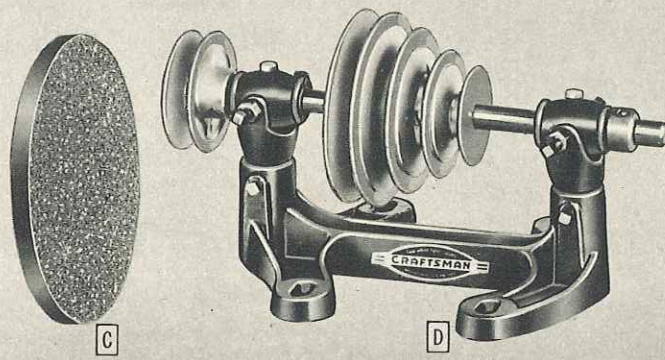

Sanding Plates

C Carefully machined and balanced. Metal plate fitted with sandpaper and setscrews. **\$275**

6-in. diam. 9 T 2158
 For 99 T 02160 lathe above or other $\frac{3}{8}$ -in. straight unthreaded spindles. 9 T 2158—6-inch diameter. Aluminum construction. Shipping weight 12 ounces. \$2.75

9 T 2341—8-inch diameter. Cast iron construction. Shipping weight 2 lbs. 8 ounces. \$3.75

For 99 TM 2318 lathe on opposite page, or other $\frac{3}{8}$ -inch straight unthreaded spindles,

9 T 2308—8-inch diameter. Cast iron construction. Shipping weight 2 lbs. 8 oz. \$3.75

Jack Shafts give your tools many more speeds

D CRAFTSMAN Cone Pulley Jack Shaft. Used with matching cone pulley on machine. Provides broad speed variations on lathes, drill presses, jig saws, sanders, grinders, etc. Speed is varied in certain definite steps. It is most commonly used between the motor and tool being driven. With proper pulleys, the speed of the jack shaft itself may be varied from motor speed, thus raising or lowering the range of speeds which are available in the driven machine. **\$595**

4-inch
 Has self-aligning, self-lubricating bronze bearings with oil reservoirs. Cast iron base. Shaft of durable cold rolled steel. Die-cast pulleys. For use with $\frac{3}{8}$ -inch V-belts. Shipping weight each 7 pounds 8 ounces.

9 T 2494—Please state size wanted. With 4-inch 4-step pulley. \$5.95
 With 5-inch 4-step pulley. 6.25

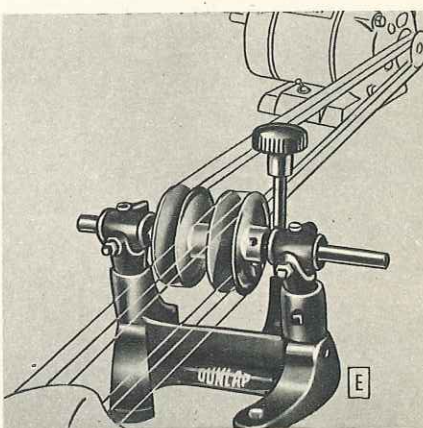

E DUNLAP Multi-speed Jack Shaft. This multi-speed jack shaft eliminates series of steps; allows gradual increase or decrease in R.P.M. of driven tool. Moving hand knob moves shaft to and from motor and causes diameter of one pulley to increase and the other to decrease. **\$829**

Permits an infinite number of speeds with 3-to-1 range between low and high speeds. Speeds of 1000 to 3000 R.P.M. are obtainable with 1750 R.P.M. motor without changing the belts, pulleys, or stopping motor. Equipped with self-aligning, self-lubricating oilite bronze bearings. Has durable cast iron base. Die-cast pulleys. Durable cold rolled steel shaft. Shipping wt. 6 lbs.

9 T 2496 \$8.29

CRAFTSMAN Grinder

REG. U.S. PAT. OFF.

**Revolves in bath of water
Won't draw temper from tools**

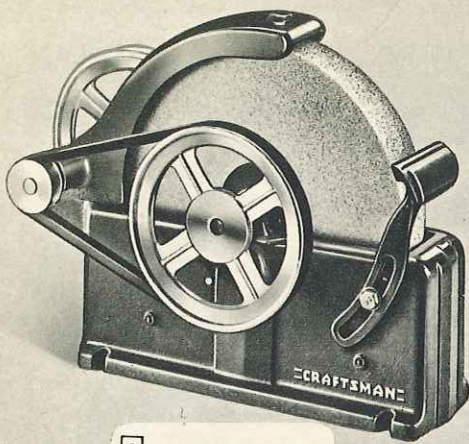

A \$11.95

99 T 06620

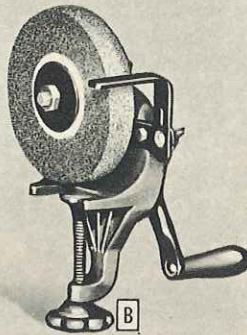

B

A Extra heavy duty! A power-driven grindstone specially designed to stand up under heavy industrial use . . . that's why it'll do such a grand job in your shop, garage, farm or home. Highest quality natural Ohio grindstone. 10-inch diameter, 1½-inch face. Built-in jack shaft reduces stone to proper speed. Heavy cast iron frame. Durable cast iron bearings. Adjustable 3-inch tool rest. Splash guard over stone. Drain plug in base. Rust-resisting gray finish. With 6-inch drive pulley (supplied). Use 1½-inch motor pulley with 1750 R.P.M. motor. Motor driving V-belt and motor pulley are not included.
99 T 06620—CRAFTSMAN Grindstone. Shipping weight 32 lbs. \$11.95
9 T 6621—Replacement Stone only for above. Shipping weight. 13 lbs. 3.75

CRAFTSMAN all-purpose Hand Grinder

B \$5.45 Heavy duty. Full-width, perfect meshing spur gears; 11-to-1 ratio. Dust-proof, leak-proof gear case. Long, protected bearing surfaces. Spring cap oil cup. Tool rest adjusts horizontally and vertically, left or right hand. 6x1-inch vitrified aluminum oxide wheel.
99 T 06626—CRAFTSMAN Hand Grinder. Shipping weight 11 pounds. \$5.45

CRAFTSMAN 6-inch Grinder

C \$8.25 Heavy duty! Ample clearance between wheel centers; plenty of high clearance for larger jobs. 9¾-inch spindle, ⅝-inch diameter, turned down to ½-inch at ends; 20-thread. Fits all standard grinding wheels and accessories. Extra long Oilite bronze bearings; oil well around each. Adjustable wheel guards and tool rests. Shielded 2-step V-drive pulley for ⅝ or ½-inch V-belt. Can be driven from below or behind. Spring cap oil cups. Gray enamel finish. Two 6x¾-inch vitrified grinding wheels: one fine, one medium grit.
99 T 06614—Shpg. wt. 19 lbs. \$8.25

4-inch Grinder

D \$4.90 Note the low price! Cast iron frame. Enclosed drive pulley. 8x⅝-inch steel spindle, turned down to ½-inch at ends; 20-thread. Fits standard accessories. Two-inch V drive-pulley for ⅝ or ½-inch V-belt (not included). Spring cap oil cups. Adjustable tool rests. Enameled gray. Two 4x¾-inch grinding wheels; one fine and one medium grit.
9 T 6628—Shpg. wt. 8 lbs. \$4.90

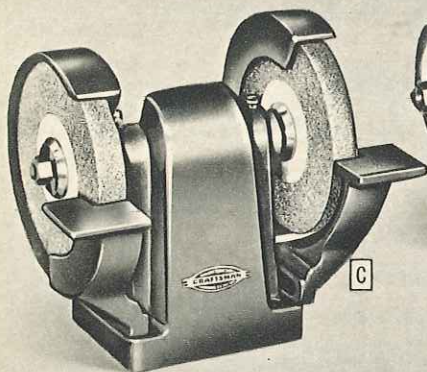

C

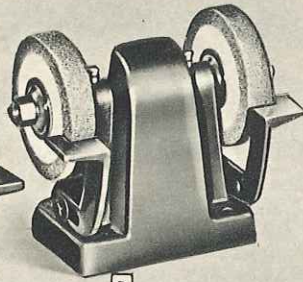

D

Low-priced Polishing Head

E \$1.80 Good quality low priced! Well-balanced. Sturdy cast iron frame. Sharpens tools, grinds, polishes, drills, etc. when used with proper accessories. Head is 7¼ in. high; spindle is 7x¼-inch, 20-thread. Stamped steel collars. Oil plugs. Can be driven from rear, above or below. Two-inch V-pulley supplied takes ⅝ or ½-inch V-belt (not included).
9 T 6615—Polishing Head. Shipping weight 3 pounds, 4 ounces. \$1.80

CRAFTSMAN all-purpose Polishing Heads

One of the handiest all-purpose tools for your shop. Used with the proper accessories, this tool will sharpen tools, remove paint or rust, grind, polish, drill, etc. Heavy cast iron frames finished in gray enamel. Spindles threaded ⅝-inch 20-thread for standard accessories. Oilite bronze bearings; oil well around each. Spring-cap oil cups can be driven from below or behind.

F \$2.60 General purpose head. Spindle ends ½-inch 20-thread. Machined flanges. Two-inch pulley for ⅝ or ½-inch V-belt.
9 T 6627—Height 7½ inches. Shpg. wt. 6 lbs. 4 oz. \$2.60

G \$4.90 Heavy duty head for bigger jobs. 9½x⅝-inch steel spindle turned down to ½-inch at ends; 20-thread. Precision built 3-jaw screw-on type chuck; ⅝-inch capacity. Machined steel collars. Two-inch pulley for ⅝ or ½-inch V-belt. Height 9¼ inch.
9 T 6647—Shpg. wt. 9 lbs. 4 oz. \$4.90

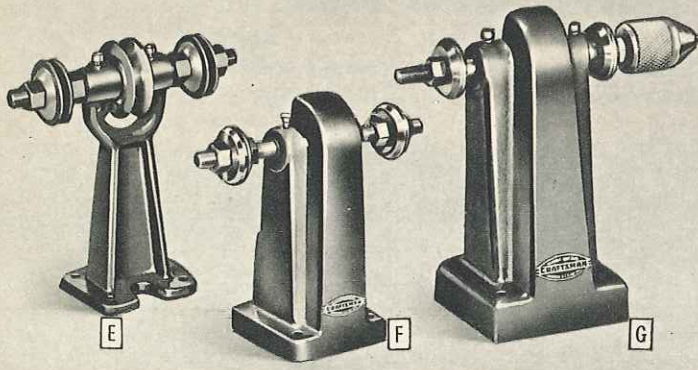

E

F

G

CRAFTSMAN Air Hammer and Chisels

REG. U.S. PAT. OFF.

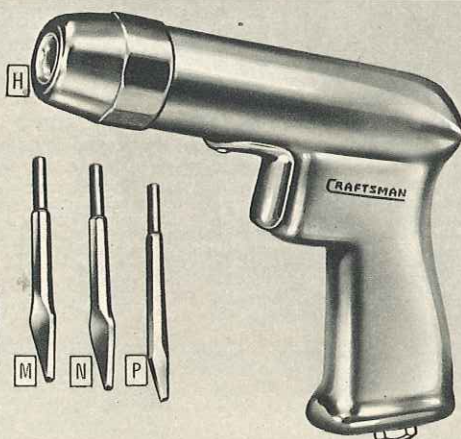

H

H \$31.95 CASH Air Hammer only \$3.50 DOWN

CRAFTSMAN Air Hammer. Exclusive! Another outstanding Craftsman tool development! Entirely new in design and principle. Features you'll find in no other air hammer made—at any price! Here are just a few:

It's built extra heavy duty for steady production work. Simple, compact. Drop forged steel body; piston of super tough ball bearing steel. All working parts heat treated and hardened.

It's air lubricated . . . no delicate valves to pamper . . . needs no oil for lubrication. Piston glides smoothly, easily. Frankly, we believe it's the finest and most trouble-free hammer on the market today.

3200 power-packed strokes per minute! Plenty of power for chiseling; scaling; metal forming and finishing; removing paint, carbon, rust, etc. Efficient one-hand trigger control. Special friction collar keeps tools from flying out of gun accidentally. Length 7 in. Uses 90-lb. 10 C.F.M. air supply.
9 T 2500—Air Hammer only. Chromium plated. Shpg. wt. 3 lbs. 12 oz. \$31.95

CRAFTSMAN Air Hammer Chisels for above. Heat treated alloy steel; hammer-forged. Average length about 7 inches. Buy a complete set for your shop!
(J) 9 T 2501—1½-inch Scaling or Goo Chisel. Shpg. wt. 12 oz. \$1.39
(K) 9 T 2502—¾-inch Chipping Chisel. Shpg. wt. 12 oz. 1.39
(L) 9 T 2503—¾-inch Cape Chisel. Shpg. wt. 12 oz. 1.39
(M) 9 T 2504—½-inch Round Nose Cape Chisel. Shpg. wt. 12 oz. 1.39
(N) 9 T 2505—¾-inch Round Nose Cape Chisel. Shpg. wt. 12 oz. 1.39
(P) 9 T 2506—¾-inch Diamond Point Chisel. Shpg. wt. 12 oz. 1.39
9 T 2507—Set of one each of six chisels above. Shpg. wt. 4 lbs. 4 oz. 7.75

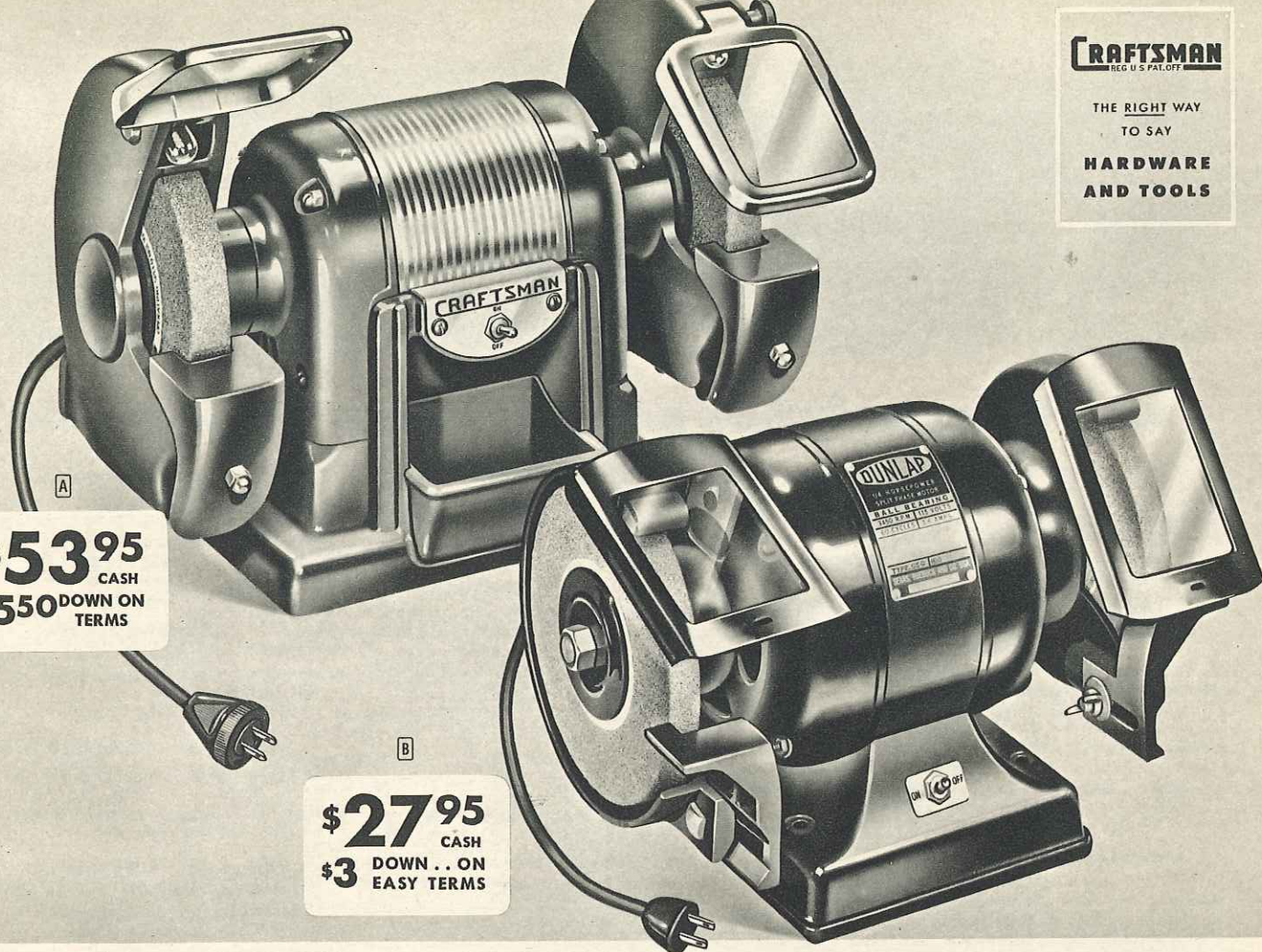
CRAFTSMAN
REG. U.S. PAT. OFF.THE RIGHT WAY
TO SAY
**HARDWARE
AND TOOLS**

\$53.95
CASH
\$550 DOWN ON
TERMS

\$27.95
CASH
\$3 DOWN . . ON
EASY TERMS

Precision built Grinders for your shop

CRAFTSMAN 1/3-H.P. Grinder

A completely new post-war model!

A An entirely new CRAFTSMAN ball bearing grinder . . . incorporating the latest and best in grinder design . . . made of finest materials by top flight tool builders! Excellent for heavy duty grinding and sharpening in garages, maintenance shops, tool rooms, workshops.

Note the rugged simplicity of design combining strength, utility and beauty. Heavy, rigid cast iron frame built for heavy duty service . . . made to take plenty of punishment! Rubber-mounted to absorb vibration. Finished in attractive CRAFTSMAN gray with contrasting chromium trim. Convenient removable built-in water pan of bright red plastic.

And there's power plenty in this husky grinder! Ample overload capacity to meet unusual power demands without burning out motor. Precision built CRAFTSMAN 1/2-H.P. capacitor motor is condenser-start induction-run type . . . ideal for heavy duty service because it combines high starting torque with minimum current consumption while running. Dynamically balanced for smooth, vibration-free operation at 3450 R.P.M. Motor ventilation openings fully baffled for protection against dust, dirt, metal grindings and abrasive grit.

Operates on 110-120 volt, 60-cycle A.C. power. Toggle switch conveniently located at front of grinder. Two-foot rubber-covered power cord and unbreakable plug.

Smooth-running precision ball bearings assure minimum friction and wear . . . conserve power . . . prolong grinder life. Bearings are sealed against dirt, dust and grit. Strong steel shaft is 3/4-inch diameter, turned down to 1/2-inch at each end.

Now you can see what you're doing! Thanks to two 7-watt work lamps—one built into each wheel guard! With your work lighted, you can do more accurate grinding and sharpening. Lamps rubber-mounted to absorb vibration, increase filament life. Easily replaced.

Here's why you're safer with a CRAFTSMAN grinder! Each grinding wheel is fully enclosed by heavy cast iron wheel guard. You're protected in case of wheel breakage. Each guard is equipped with rear dust chute that leads away grindings and abrasive particles. Dust bags may be easily attached. Each wheel is covered with shatterproof glass eye shield, mounted in adjustable chromium plated die cast frame. Useful glass area of eye shield is 3 1/4 x 3 3/4 inches; outer dimensions of frame 4 1/4 x 4 3/4 inches. Ground cast iron tool rests adjustable for wheel wear and proper grinding position.

Two finest industrial quality CRAFTSMAN vitrified aluminum oxide grinding wheels . . . one 36 grit for coarse grinding and one 70 grit for fine grinding and finishing. Wheel diameter greater than motor diameter for grinding work across face of machine. Both wheels 7 inches in diameter, 1 inch thick. Thirteen-inch clearance between wheels. Each wheel scientifically bonded and vitrified in electrically controlled furnaces. Face and sides dressed square. Perfectly balanced. Operate safely at rated speed of 3450 R.P.M. Dimensions (without eye shields and tool rests): Height 12 inches; width 17 inches; depth 8 3/4 inches. 99 TM 2618—CRAFTSMAN 1/3-H.P. ball bearing Grinder. Shipping weight 98 lbs. **\$53.95**

DUNLAP 1/4-H.P. Grinder

Dependable quality...low in price!

B Designed and constructed to handle most grinding jobs in small shops and for general maintenance work. An excellent utility grinder for any shop. Smaller and less expensive than our CRAFTSMAN 1/3-H.P. model at the left. Built to give years of trouble-free service.

Equipped with 1/4-H.P. DUNLAP split phase motor that operates on 110-120 volts 60-cycle A.C. power. Rated speed is 3450 R.P.M. Built-in on-off toggle switch is conveniently located at front of grinder. Two-foot rubber-covered cord and unbreakable plug.

Precision ball bearings, protected against dirt, dust, grindings and abrasive particles. You get smooth, dependable, vibration-free operation with minimum power loss due to friction. The 5/8-inch steel shaft is turned down to 1/2-inch at wheel ends.

Two 6 x 3/4-inch fully vitrified CRAFTSMAN grinding wheels—one 36 grit wheel for coarse grinding and one 70 grit wheel for finer grinding and finishing. Clearance between wheels is eleven inches. Wheels are made of finest aluminum oxide grit, bonded and vitrified in electrically controlled furnaces. Well balanced . . . true running . . . made to cut cool, fast and free. Operate safely at rated grinder speed of 3450 R.P.M.

Cast iron wheel guards protect you against injury due to wheel breakage. Shatterproof glass eye shields in adjustable steel frames protect you against flying particles and sparks from grinding wheels. Useful glass area of eye shields 3 1/4 x 4 inches; outer dimensions of eye shield frames is 4 x 5 1/4 inches. Removable, adjustable tool rests steady your work . . . assure greater accuracy.

Durable cast iron frame for strength and rigidity. Finished in black enamel. Rubber-mounted for freedom from vibration.

Over-all dimensions (without eye shields and tool rests): Height 8 3/4 inches; width 12 1/2 inches; depth 8 inches. 99 T 02616—DUNLAP 1/4-H.P. Grinder. Shipping weight 43 lbs. **\$27.95**

Yes, you can buy your grinder on Easy Terms!

Find yourself a little short on cash? Stop worrying! Here's how you can put a new grinder in your shop NOW . . . pay for it as you use it. Only 10% down on Sears Easy Terms . . . balance in convenient monthly payments. If you already have a Sears Easy Terms account, just add your grinder to your present account. See inside back cover for complete details.

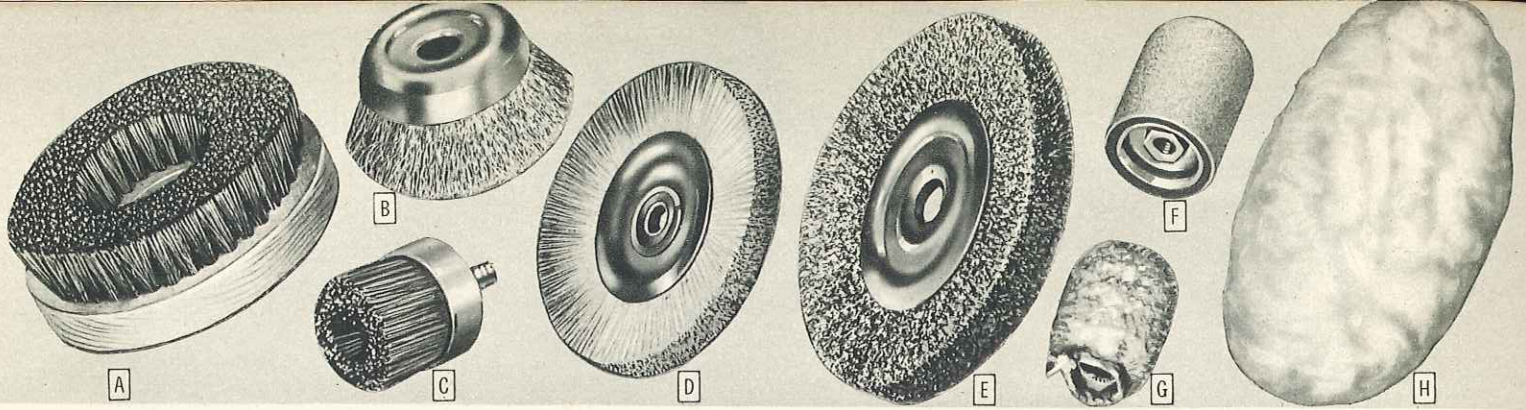

Accessories for lathes, polishing heads, flexible shafts

Floor Brush

A One of our best selling accessories. Very handy for scrubbing, waxing, etc. 1-inch long Tampico fibers are closely and securely set in a 6-inch diameter hardwood block. Has 1/2-inch arbor hole for mounting on lathe, polishing head, flexible shaft, or any 1/2-inch spindle.
9 T 6487—Shipping weight 11 ounces...Each \$1.10

Wire Cup Brush

B Densely filled with special crimped steel wire bristles, 1 1/2 inches long, evenly distributed and rigidly secured in a heavy cup shaped metal holder. Designed for high speed operation on portable or stationary equipment. Recommended for removing scale, rust, paint or weld spatter from rough metal surfaces. Brushing surface has 1 1/2-in. face, 2 3/4-in. outside diameter; 1/2-in. arbor hole.
9 T 6485—Shipping weight 4 ounces...75c

Carbon Removing Brush

C Used by auto mechanics for hard-to-get-at jobs such as carbon removing, brushing motor parts, engine heads, castings of irregular shape, etc., inaccessible to rotary wire wheel brushes. The 1-inch long, straight, tempered steel wires are rigidly secured in sturdy metal holder. Ferrule diameter 1 inch; 1/4-inch diameter steel shank.
9 T 6484—Shipping weight 4 ounces...Each 70c

Tampico Fiber Wheel Brush

D Tampico fiber secured by metal center. Diameter 6 inches; 3/8-inch face; 1/2-inch arbor hole. Ideal for cleaning, polishing, buffing, etc.
9 T 6486—Shipping weight 8 ounces...Each 60c

Steel Wire Wheel Brushes

E Crimped steel wire; metal center. For removing paint rust, scale; for buffing tires, etc. Order by catalog number, stating wheel diameter and arbor hole size.

Diameter	Face Width	Center Hole	Shipping weight	Each
9 T 6480—Coarse. Made from No. 33 wire				
4 inch	1/16-inch	1/2-inch	.5 oz.	\$.55
6 inch	1/16-inch	1/2-inch	.11 oz.	.70
6 inch	1/8-inch	3/8-inch	.11 oz.	.70
8 inch	1/16-inch	1/2-inch	1 lb.	.90
8 inch	1/16-inch	3/8-inch	1 lb.	.90

9 T 6482—Fine. Made from .006-inch diameter wire				
4 inch	3/16-inch	1/2-inch	.5 oz.	\$0.67
6 inch	1/8-inch	1/2-inch	.11 oz.	.90
6 inch	1/4-inch	3/8-inch	.11 oz.	.90
8 inch	3/16-inch	1/2-inch	1 lb.	1.15
8 inch	3/16-inch	3/8-inch	1 lb.	1.15

9 T 6483—Coarse. Heavy duty. Made from No. 33 wire				
4 inch	1/8-inch	1/2-inch	.14 oz.	\$1.59
6 inch	1/8-inch	1/2-inch	1 lb. 12 oz.	2.20
6 inch	1/4-inch	3/8-inch	1 lb. 12 oz.	2.20
8 inch	1/8-inch	1/2-inch	2 lbs. 12 oz.	2.60
8 inch	1/8-inch	3/8-inch	2 lbs. 12 oz.	2.60

Sanding Drums

F Complete with adapter and medium grit sleeve. Diameter 2 1/4 inches; length 3 inches. Shipping weight 12 ounces
9 T 2524—Fits 1/2-inch 20-thread shaft...\$1.37
9 T 2520—Fits either 1/2-inch 24-thread or 3/8-inch 24-thread shaft...1.37

Sanding Sleeve

Not shown. For replacement use on above sanding drums. Please be sure to state grit wanted; fine, medium or coarse.
9 T 2522—Shipping weight 2 oz...Each 14c

Lambswool Polishing Drum

G Made of lamb's wool; 1-inch pile. Diam. 2 1/4 in.; length 3 in. Slips over sanding drum above for polishing curved and irregular surfaces.
9 T 2533—Shipping weight 3 oz...Each 75c

Lambswool Polishing Bonnets

H Fit over sanding plates. Polishes wax surfaces to a high finish. Shpg. wt. each 8 oz.
9 T 2527—Diameter 7 inches. Fits over 6-inch sanding plate. 1-inch pile...Each \$1.05
9 T 2528—Diameter 8 inches. Fits over 7-inch sanding plate. 1 1/4-inch pile...Each 1.20
9 T 2539—Diameter 9 inches. Fits over 8-inch sanding plate. 1 1/4-inch pile...Each 1.50

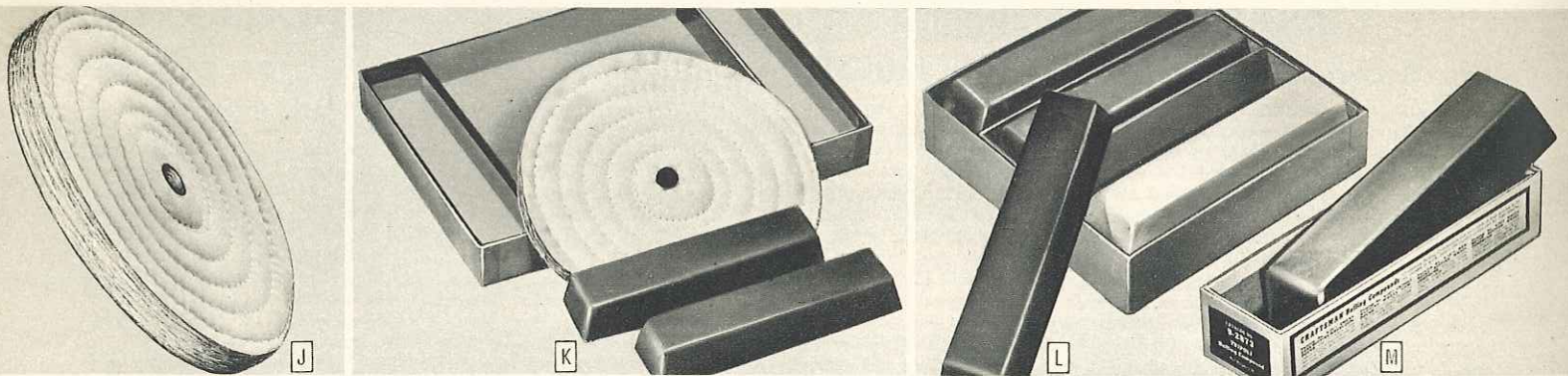

Buffing Wheels

J Spiral-sewed Buffs. Made from full disc unbleached muslin 64x64 thread count. State diameter.

Cat. no.	Diam.	Center Hole	Layers	Shpg. wt.	Each
9 T 6491	4 in.	1/2 in.	18	.1 oz.	\$0.29
Single Thickness Buffs	6 in.	1/2 in.	18	.2 oz.	.49
	8 in.	1/2 in.	18	.4 oz.	.69
9 T 6493	4 in.	1/2 in.	32	.2 oz.	.49
	6 in.	1/2 in.	32	.4 oz.	.69
Double Thickness Buffs	8 in.	1/2 in.	32	.7 oz.	1.20
	10 in.	1/2 in.	32	1.2 oz.	1.75
	12 in.	1/2 in.	32	1.5 oz.	2.40
	14 in.	1 in.	32	1 lb. 2 oz.	3.10
	16 in.	1 in.	32	1 lb. 4 oz.	3.95

Loose Buffs. Same quality as above. Rows of sewing indicated are concentric. Easily removed. State diameter.

Catalog number	Diameter	Center Hole	Rows of Sewing	Layers	Shpg. wt.	Each
9T6494	4 in.	1/2 in.	2	32	.2 oz.	\$0.42
	6 in.	1/2 in.	2	32	.4 oz.	.67
	8 in.	1/2 in.	3	32	.7 oz.	1.15
	10 in.	1/2 in.	4	32	1.2 oz.	1.70
	12 in.	1 in.	5	32	1.5 oz.	2.30
	14 in.	1 in.	6	32	1 lb. 2 oz.	3.00

CRAFTSMAN Buffing Set

K Set includes 6-inch double thickness sewed muslin buffing wheel, with 1/2-inch center hole; 6-oz. bar of rouge buffing compound; 5-oz. bar of Tripoli brown buffing compound. Handy set for your shop.
9 T 2864—Shipping weight 1 lb. 1 oz...Set \$1.05

CRAFTSMAN Buffing Compound Set

L Set includes one bar of the following compounds: Emery (black), Tripoli (brown), Red Rouge and White Rouge. Each bar 5 1/4 x 1 3/8 x 1 inch; weighs 5 ounces each.
9 T 2896—Shipping weight per set 2 lbs...Set 75c

CRAFTSMAN Buffing Compound Bars

Sold individually. Each bar 5 1/4 x 1 3/8 x 1 inch. Actual weight of each bar 5 ounces. Shpg. wt. each 8 oz.
9 T 2859—Emery. Black colored compound. Removes rust from tools, golf clubs, iron, etc. Per bar...22c
9 T 2861—Tripoli. Brown colored compound. Use on aluminum, copper, brass, wood, plastics. Per bar...22c
9 T 2897—Red Rouge. Produces high luster on silverplate, gold, and all soft metals. Per bar...22c
9 T 2860—White Rouge. Produces high luster on stainless steel, chromium, etc. Per bar...22c

CRAFTSMAN Buffing Compounds

M Economical larger size bars, 7 1/4 x 2 1/4 x 1 1/2 inches. For industrial or hobby shop use. Made of the highest quality materials. Each bar individually packed in cardboard container.
9 T 2871—Emery. Black colored compound. Used to remove rust from tools, golf clubs, iron etc. Actual weight of bar 1 pound. Shipping weight 1 pound 4 ounces...Per bar 47c
9 T 2873—Tripoli. Brown colored compound. For use on aluminum, brass, copper, wood, plastics etc. Actual weight of bar 1 pound. Shipping weight 1 pound 4 ounces...Per bar 47c
9 T 2874—Red Rouge. Ideal for giving high luster to silverplate, gold, sterling and all soft metals. Actual weight per bar 1 pound 3 ounces. Shipping weight 1 pound 8 ounces...Per bar 70c
9 T 2872—White Rouge. Ideal for giving high luster to stainless steel, cast brass, chromium, aluminum, etc. Actual weight per bar 1 lb. 3 oz. Shipping weight 1 pound 8 ounces...Per bar 65c

Buy on Sears Easy Terms. Everything that Sears sells is available on convenient Sears Easy Terms. Only 10% down; the balance monthly. See inside back cover for complete details.

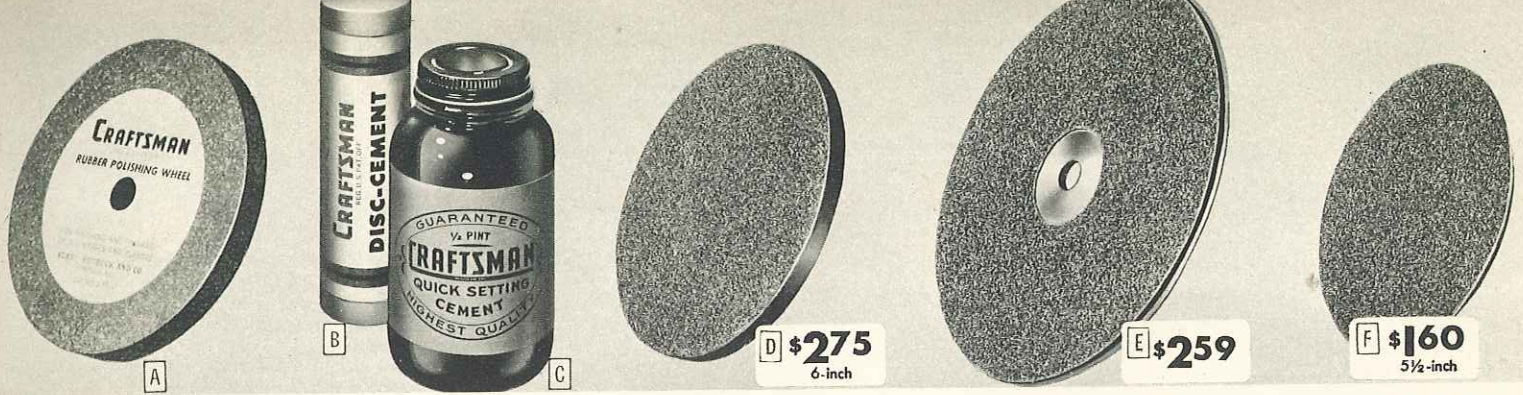

Accessories for Lathes, Sanders, Polishing Heads, etc.

Rubber Polishing Wheel

A CRAFTSMAN. Made of rubber with the cutting abrasive distributed through it! For polishing and finishing all hard metals and plastics. Easy to shape for getting into difficult places. Ideal for rust removal, die work, deburring, putting a super-keen edge on knives, etc. 1/2-in. thick; 1/2-in. bore. Maximum speed recommended: 4-in., 3800 R.P.M.; 6-in., 2500 R.P.M. Choice of fine, medium or coarse grit. *Please state grit wanted.*

9 T 2928—4-inch diameter. Shipping weight 9 ounces. . . . \$1.05
9 T 2929—6-inch diameter. Shipping weight 1 lb. 8 oz. . . . \$1.89

B Disc Cement. Holds sanding discs to metal or wood sanding plates. Non-drying. Choice of 4 1/4 or 16 oz. sticks.

9 T 2219—4 1/4 oz. Shpg. wt. 6 oz. 32c
9 T 2229—16 oz. Shpg. wt. 18 oz. 70c

C Cement. Fastens abrasive discs to metal plates. Sets quickly; holds firm. Shpg. wt. 1 lb. 2 oz.
9 T 2535—1/2-pint. 79c

Sanding Plates, Wheels, and Replacement Sanding Discs

Sanding Plates. Cast iron construction. Carefully balanced and machined. Set screw is provided to lock plate securely on spindle. Each plate has one abrasive disc for wood, attached. For extra abrasive discs, see bottom of page, at right. *Be sure to check spindle size before ordering.*

D 6-inch diameter. Fits woodworking lathe 99 T 02160 (see page 19), or any 5/8-inch straight unthreaded spindle.

9 T 2158—Shipping weight 12 ounces. \$2.75

8-inch diameter. Fits woodworking lathe 99 T 02160 (see page 19), or any 5/8-inch straight unthreaded spindle.

9 T 2341—Shipping weight 2 pounds 8 ounces. \$3.75

8-inch diameter. Fits woodworking lathe 99 TM 2318 (see page 18), or any 3/4-inch straight unthreaded spindle.

9 T 2308—Shipping weight 2 pounds 8 ounces. \$3.75

E Sanding Wheel. 8-inch diameter. 1/2 or 3/8 inch bore. Steel. Fits any 8-inch or larger bench saw, having 1/2 or 3/8-inch arbor (see pages 1 and 2). Has one medium and one coarse abrasive disc for wood, attached. *State size bore.*

9 T 2272—Shipping weight 4 pounds. \$2.59

Replacement Sanding Discs for 9 T 2272 sanding wheel above. 8-inch diameter. 2-inch center hole fits over any arbor. Package of six assorted: 2 each of fine, medium and coarse grit.

9 T 2273—Shipping weight 10 ounces. Package of six. 60c

F Flexible Sanding Plates. Fit polishing heads and flexible shafts (pages 20 and 24), and any other spindles threaded as listed below. With one medium grit abrasive disc for wood or metal attached. For extra abrasives, see replacement discs below. *Check spindle size and thread before ordering.*

5 1/2-inch diameter. 3/8-inch thick flexible rubber pad, with 3 1/2-in. diameter steel backing on hub. Shpg. wt. each 14 oz.

9 T 2547—For 1/2-inch x 20 thread spindle. \$1.60

9 T 2540—For 5/16-inch x 24 thread spindle. 1.60

7-inch diameter. Has 1/2-inch thick flexible rubber pad with 4 3/8-inch diameter steel backing on hub. Shpg. wt. each 14 oz.

9 T 2548—For 1/2-inch x 20 thread spindle. \$2.35

9 T 2544—For 1/2-inch x 24 thread spindle. 2.35

Replacement Sanding Discs. Fit 5 and 7-inch flexible sanding plates above. Medium grit abrasive; for wood or metal.

9 T 2541—5 1/2-inch diameter. Shpg. wt. 2 oz. Pair 33c

9 T 2545—7-inch diameter. Shpg. wt. 3 oz. Pair 49c

CRAFTSMAN Sanding Plate. (Not shown.) 7-in. diam. steel; rubber backed. 1/2-in. collet-type mounting; fits any 1/2-in. shaft or spindle; plain or threaded. Will not injure threads.

With one medium grit abrasive disc for wood or metal.

9 T 2549—Shipping weight 2 pounds. \$2.95

Replacement Sanding Discs. For 9 T 2549 plate above. 7-in. diameter. Centering hole. Pre-glued for easy replacement. Choice of fine, medium or coarse grit. *State grit wanted.*

9 T 2546—Shipping weight 5 ounces. Pair 49c

Build your order up to \$10 or more and buy on Sears convenient Easy Terms . . . see inside back cover for details

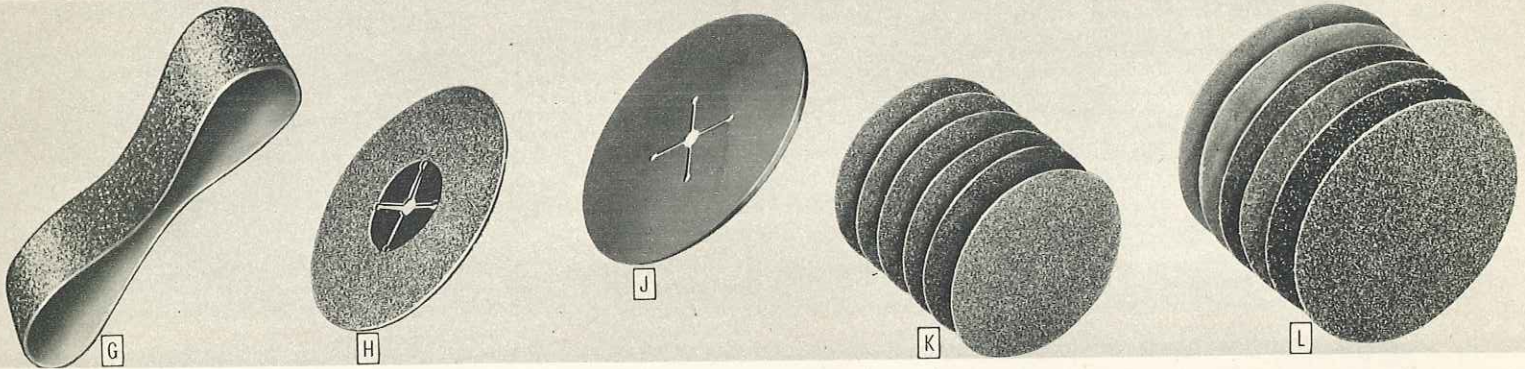

Sanding Belts

G Endless construction. In choice of fine, medium or coarse grit. *State grit wanted.*

9 T 2167—6x48 inches. Aluminum oxide on cloth. For sanding hardwood or metal. Fits 99 TM 2235 sander (see page 16). Shpg. wt. 8 oz. . . \$1.10

9 T 2211—4x52 1/2 inches. Aluminum oxide on cloth. For wood or metal. Fits Sears former No. 2210 sander. Shpg. wt. 10 oz. 85c

9 T 2215—4x36 inches. Aluminum oxide on cloth. For wood or metal. Fits Sears former No. 2213 sander. Shpg. wt. 4 oz. 60c

9 T 2218—4x36 inches. Garnet on cloth. For use on wood only. Fits Sears former No. 2213 sander. Shipping weight 4 ounces. 63c

Resin-bonded Abrasive Discs

H Outlast glue-bonded discs from 2 to 2 1/2 times! Won't "soften up" under high speeds. Fine for curved surfaces. Made of aluminum oxide grit, firmly bonded to pliable fiber back. 7-inch discs come in No. 24, 36, 50 or 80-grit; 9 1/2-inch discs in No. 24, 36, or 50-grit. *Please state grit wanted.*

7-inch discs		Center hole	Shpg. wt.	Each
9 T 2220	1/2 inch	1/8 inch	5 oz.	33c
9 T 2223	3/8 inch	1/8 inch	5 oz.	33c
9 1/2-in. discs		Center hole	Shpg. wt.	Each
9 T 2221	1/2 inch	1/8 inch	6 oz.	44c
9 T 2224	3/8 inch	1/8 inch	6 oz.	44c

J Fiber Backing Pads. Used for backing up abrasive discs for more rigidity. With 1/2 or 3/8-inch center hole. *Please state center hole size wanted.*

9 T 2225—7-inch diameter. Shipping weight 4 oz. Each 59c

9 T 2226—9 1/2-inch diameter. Shipping wt. 5 oz. Each 72c

Replacement Abrasive Sanding Discs

K 9 T 2532—6-inch diameter. Aluminum oxide on paper. For sanding wood or metal. Fits any 6-inch sanding plate. 6 discs of same size grit in package. Choice of fine, medium or coarse. *State grit size wanted.* Shpg. wt. 6 oz. . . . 6 fine for 33c
6 medium for 33c 6 coarse for 33c

L 8-inch diameter. 6 assorted; 2 each, fine, medium and coarse grit. Shipping weight per package, 8 ounces.

9 T 2216—Garnet on paper. For wood. Fits Sears former No. 2213 sander, and 9 T 2341 and 9 T 2308 sanding plates above. 6 for 59c

9 T 2217—Aluminum oxide on paper. For wood or metal. Fits same sander and sanding plates as 9 T 2216 above. 6 for 60c

9 T 2155—9-inch diameter. Aluminum oxide on paper. For wood or metal. Fits 99TM2235 sander (see page 16). 6 assorted: 2 each, fine, medium and coarse grit. Shpg. wt. 8 oz. . 6 for 72c

9 T 2206—10-inch diameter. Aluminum oxide on paper. For wood or metal. Fits Sears former No. 2210 sander. 6 assorted: 2 each, fine, medium and coarse grit. Shpg. wt. 10 oz. . 6 for 95c

Everything Sears sells may be purchased on Easy Terms . . . see inside back cover

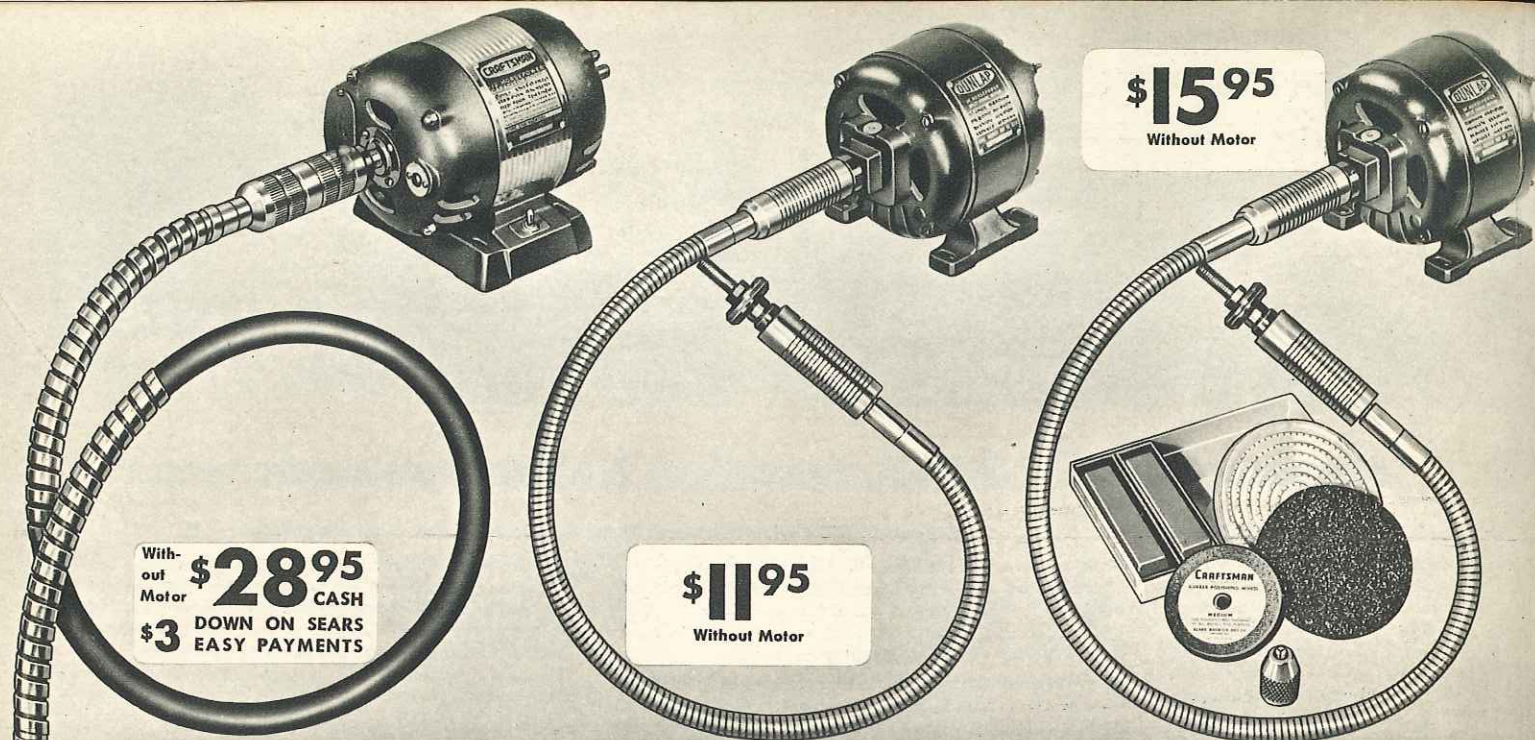

CRAFTSMAN Flexible Shafts . . . many tools in one

Versatile shop tools that handle scores of jobs just by changing accessories! They take the hard work out of sanding, polishing, grinding, drilling; removing paint, carbon or rust. Invaluable time and labor savers for the home, farm, shop, garage or factory. Take the tool to the work, instead of taking the work to the tool.

Famous CRAFTSMAN professional quality, with finest materials and workmanship built into every detail to give dependable, lasting service. Use with accessories shown below and on pages 22 and 23. To protect hands and eyes, use wheel guard (listed below) and goggles or face shield (see page 39).

CRAFTSMAN 72-inch Flexible Shaft

Extra long . . . and tough. Ideal for heavy duty use in garages, shops, factories and industrial plants.

Chrome plated steel hand piece and motor coupling both have extra large precision ball bearings for smoother operation and longer wear. Knurling on hand pieces gives firm, non-slip grip. Black, rust resistant, plated steel end fittings.

Extra long, 72-inch shaft. Fits 1/2-inch motor shaft. Spindle is 1/2-inch, 20-thread. Core is made of 3/8-inch high carbon steel wire, helically-wound, multiple-strand. Inner casing is made of helically wound steel covered with heavy, abrasion-resistant, rubber jacket . . . steel impregnated . . . will not scratch surfaces.

Unusually flexible! Absolutely leakproof! Supports core evenly. The spiral steel chrome finish outer reinforcement at each end of shaft protects jacket. Complete with casing, core, motor coupling, hand piece and simple instructions for using.

- 99 T 02627—CRAFTSMAN 72-inch Flexible Shaft without motor. Shipping weight 11 lbs. \$28.95
- 99 T 02629—CRAFTSMAN 72-inch Flexible shaft with 1/2 H.P. 1750 R.P.M. capacitor ball bearing motor for 110-120 volt 60 cycle A.C. Shpg. wt. 46 lbs. \$55.95
- 9 T 2626—Extra Core for above flexible shafts. Shipping weight 2 pounds 5.95

CRAFTSMAN 50-inch Flexible Shaft

General purpose flexible shaft that has hundreds of uses in the home, garage or repair shop. It's smooth . . . quiet running . . . and transmits power from motor to driven tool with minimum power loss.

50 inches long. Fits any 1/2-inch motor shaft. Smooth operating, ball bearing hand piece, with 1/2-inch 20-thread spindle. The motor coupling runs on needle bearings. Hand piece and motor coupling are made of non-rusting aluminum alloy.

Two layers of steel in casing. Inner layer is tempered spring steel and outer layer is soft steel. Practically leakproof. 5/16-inch core is made of helically-wound high carbon steel wire. Complete with casing, core, motor coupling, hand piece and instructions.

- 99 T 02633—CRAFTSMAN 50-inch Flexible Shaft without motor. Shipping weight 5 lbs. \$11.95
- 99 T 02619—CRAFTSMAN 50-inch Shaft with 1/4 H.P. 1750 R.P.M. sleeve bearing split phase motor for 110-120 volt 60 cycle A.C. Shpg. wt. 29 lbs. \$24.50
- 9 T 2634—Flexible Shaft Extension (not shown). 38 inches long. Same construction as above flexible shaft. Without hand piece or motor coupling. Shipping weight 3 pounds 6 ounces \$3.95
- 9 T 2622—Extra Core for above flexible shaft or extension. Shipping weight 1 pound 2.55

CRAFTSMAN 50-in. Flexible Shaft Set

Makes grinding, sanding, cleaning, polishing, drilling, and rust removal far easier. Set includes:

Flexible Shaft. 50 inches long over-all; fits 1/2-inch motor shaft. Casing has 2 layers of steel consisting of an inner layer of tempered spring steel and an outer layer of soft steel. Ball bearings in hand piece; needle bearings in motor coupling. Aluminum alloy housings. Black, rust-resistant plated steel end fittings. Has 5/16-inch core of multiple-strand, helically-wound high carbon steel wires. Spindle is 1/2-inch by 20-thread.

Motor. DUNLAP 1/4-H.P. 1750 R.P.M. sleeve bearing split-phase for 115 volt 60-cycle A.C.

Buffing Equipment. 6-in. double-thickness sewed buff; 6-oz. bar of rouge buffing compound for soft, nonferrous metals; 5-oz. bar of Tripoli (brown) buffing compound for aluminum, brass, wood, plastics, etc. Also 4-in. rubber and abrasive polishing wheel, 1/2 in. thick, 1/2-in. bore; 5 1/2-in. flexible sanding plate with medium grit abrasive; 3-jaw chuck, screw-on type, 1/2-in. capacity.

- 99 T 02651—Complete set, with motor. Shipping weight 33 pounds \$29.95
- 99 T 02630—Complete set, without motor. Shipping weight 8 pounds 10 ounces 15.95

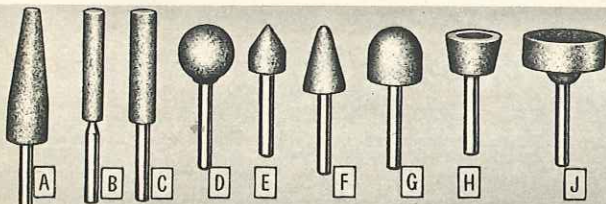

Mounted Grinding Tools for flexible shafts

Made from highest quality vitrified aluminum oxide. Accurately mounted on 1/4-inch steel shafts; run true. For finish work, die cutting, or other grinding work. Sizes given are stone sizes. Use 9 T 6458 for sharpening 9 T 2420 hollow chisel (page 30).

Catalog No.	Diameter	Length	Shipping weight	Each
A 9 T 6461	3/8 inch	2 1/2 inch	3 ounces	.65c
B 9 T 6463	3/8 inch	2 inches	3 ounces	.55c
C 9 T 6462	1/2 inch	2 inches	3 ounces	.55c
D 9 T 6459	1 inch	1 inch	3 ounces	.55c
E 9 T 6458	1 1/8 inch	1 1/8 inch	3 ounces	.55c
F 9 T 6457	1 1/2 inch	1 1/8 inches	3 ounces	.55c
G 9 T 6460	1 inch	1 inch	3 ounces	.55c
H 9 T 6443	1 inch	1 1/2 inch	3 ounces	.45c
J 9 T 6444	1 1/2 inches	1 1/2 inch	3 ounces	.45c

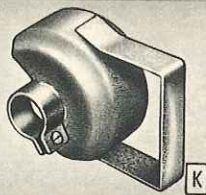

Wheel Guard

K CRAFTSMAN. Protects hands and eyes from the danger of flying particles and grit. A must in every shop. Has hand grip. Fits 99 T 02619 and 99 T 02633 (listed above) or any flexible shaft with 1 1/8-inch diameter hand piece. For use with any 4-inch grinding wheel or wire wheel. For extra protection and safety, see goggles listed on page 39. Shipping weight 2 pounds 4 ounces. 9 T 2637 \$3.65

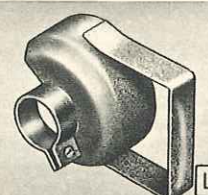

Wheel Guard

L CRAFTSMAN. A safety necessity. Don't take unnecessary chances of injury from flying particles. Has hand grip. Made to fit 99 T 02629 and 99 T 02627 (listed above) or any flexible shaft with 1 1/2-inch diameter hand piece. For use with any 4-inch grinding wheel or wire wheel. For extra protection and safety, see goggles listed on page 39. Shipping weight 2 pounds 4 ounces. 9 T 2638 \$3.65



Angle Head

M CRAFTSMAN. For getting into tight places or putting more pressure on grinding wheels, brushes, sanding and polishing discs. Cast aluminum head. Ball bearings take thrust; needle bearings radial load. 1-to-1 gear ratio. Removable, rubber grip handle for easy guidance. For 99 T 02629 and 99 T 02627 (listed above) only! Shipping wt. 2 lbs. 8 oz. 9 T 2628 \$31.50

You can afford to equip your shop completely with CRAFTSMAN tools . . . Use Sears Easy Terms . . . See inside back cover for details

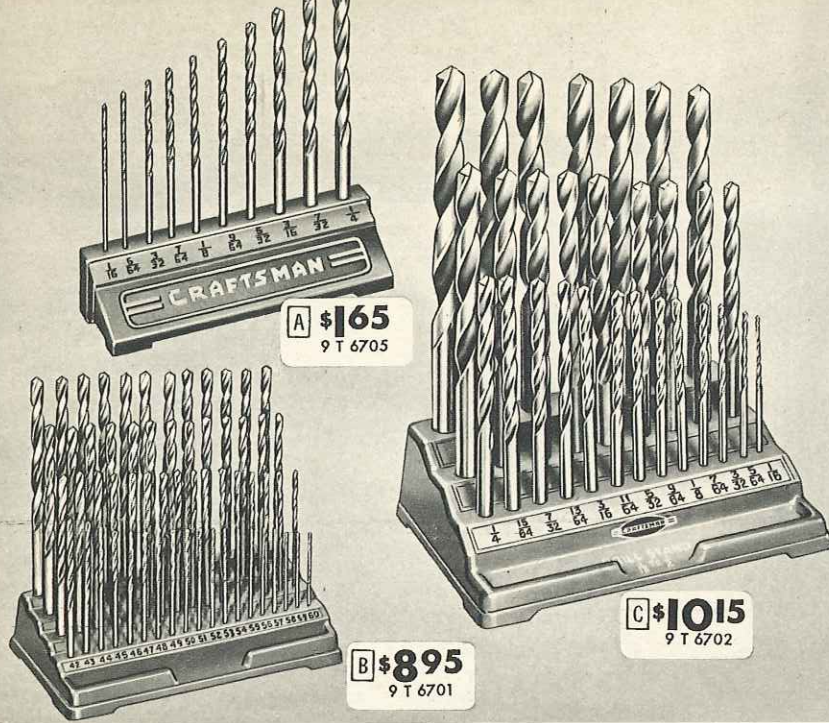

A \$165
9 T 6705

B \$895
9 T 6701

C \$1015
9 T 6702

CRAFTSMAN Drill Sets

REG. U. S. PAT. OFF.

Our finest CRAFTSMAN twist drills for home, shop and industrial use. Real professional quality in every detail. Highest quality steels, expertly tempered and hardened to stand up under long, hard use. Precision ground to exact size; cut cleanly and easily in wood or metal.

Your choice of low speed carbon tool steel or high speed steel. Use carbon tool steel

drills for hand, breast or bench drills operating at relatively low speeds; use high speed drills for high speeds in electric drills and power-driven drill presses.

These sets come in handy drill stands, which help you keep drills in order so you can find the proper drill easily. Hole sizes are clearly marked for quick selection of drills. Drill stands may be used as drill gauges.

A Ten-piece drill sets in drill stands. Sizes $\frac{1}{16}$, $\frac{3}{64}$, $\frac{1}{8}$, $\frac{3}{32}$, $\frac{1}{4}$, $\frac{5}{16}$, $\frac{3}{8}$, $\frac{1}{2}$ -inch. Shpg. wt. per set, 8 oz.

9 T 6705—10-pc. carbon tool steel drill set and stand. \$1.65

9 T 6703—10-pc. high speed steel drill set and stand. \$3.25

B Sets of sixty wire gauge drills sizes 1 to 60, in drill stands. Shipping weight, per set, 2 pounds 12 ounces.

9 T 6701—60-pc. carbon tool steel drill set and stand. \$8.95

9 T 6707—60-pc. high speed steel drill set and stand. \$18.50

C Sets of twenty-nine drills, sizes $\frac{1}{16}$ to $\frac{1}{2}$ -inch by 64ths, in drill stands. Shipping weight, per set, 4 lbs. 2 oz.

9 T 6702—29-pc. carbon tool steel drill set and stand. \$10.15

9 T 6704—29-pc. high speed steel drill set and stand. \$21.95

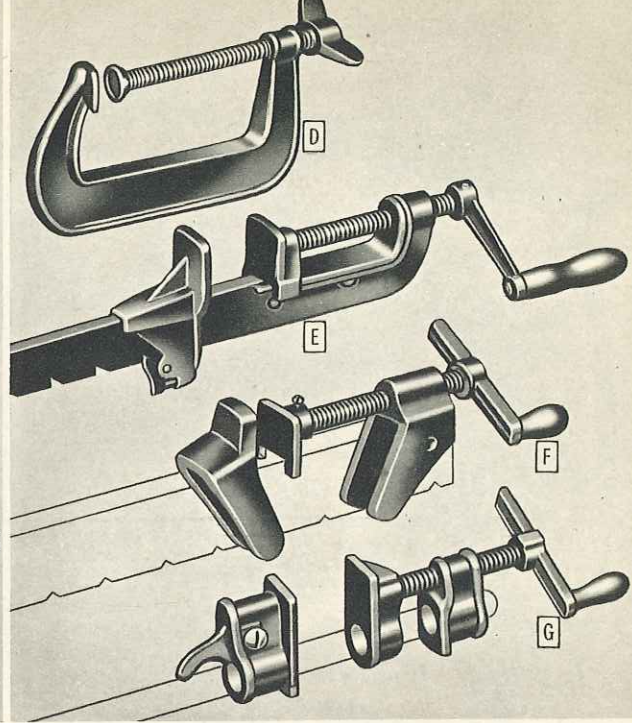

D Iron C Clamps. Strong clamps with Acme-threaded screw. Self-adjusting swivel head.

9 T 6667—Please state size

Opens to	Shpg. wt.	Each
3 inches	.1 lb. 8 oz.	\$.079
4 inches	.2 lbs. 2 oz.	.098
5 inches	.2 lbs. 8 oz.	1.15
6 inches	.3 lbs. 2 oz.	1.39
8 inches	.4 lbs. 8 oz.	1.98

E Cabinet Makers' Steel Clamp. T-bar type. Bar is $1\frac{1}{2} \times \frac{1}{2} \times \frac{3}{16}$ in. Sliding jaw has $1\frac{1}{2}$ -inch face; locks in notches. Easy-operating crank.

99 T 06676—Please state size.

Opens to	Shpg. wt.	Each
3 feet	8 lbs.	\$4.45
4 feet	9 lbs.	4.75

F Gluing Clamp. Wood bar type. For any length wood bar, $1\frac{3}{8} \times 2\frac{3}{8}$ inches. Malleable iron. Sliding jaw has $1\frac{1}{2} \times 1\frac{1}{4}$ -inch face. Easy working. Crank adjustment. With screws; without wood bar. Shpg. wt. 4 lbs. 8 oz. 9 T 6673. \$1.98

G Gluing Clamp. Adjustable pipe style. Use with any $\frac{3}{4}$ -inch threaded pipe. Malleable iron. Convenient crank adjustment. Sliding jaw has $1\frac{1}{4} \times 1\frac{1}{8}$ -inch face; handy lever lock. With cap for end of pipe; without wood bar. Shpg. wt. 3 lbs. 14 oz. 9 T 6674. \$2.45

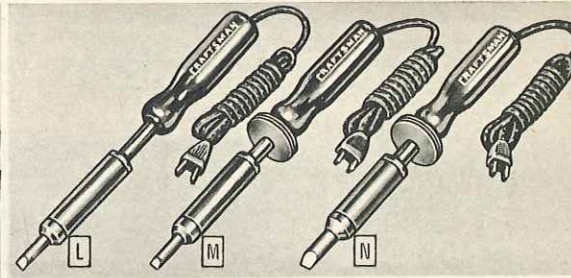
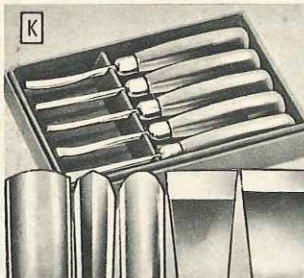
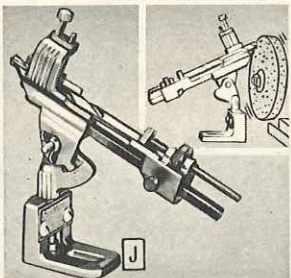
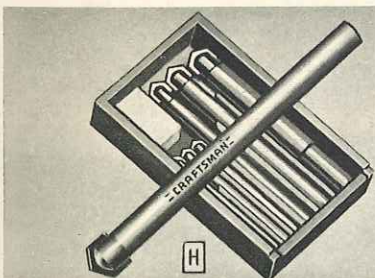

Carbide-tip Drills

H CRAFTSMAN. Very useful for drilling stone, marble, concrete, etc. $\frac{1}{4}$ inch. Strongly made of steel, with special carbide tips. Round shanks, for use with electric drills or hand or breast drills. Drill quickly, cleanly and accurately. Require less sharpening... last longer.

9 T 6711—State size.

Size	Length	Shpg. wt.	Each
$\frac{3}{16}$ in.	4 in.	4 oz.	\$1.45
$\frac{1}{8}$ in.	4 in.	4 oz.	1.65
$\frac{3}{16}$ in.	4 in.	6 oz.	1.75
$\frac{1}{4}$ in.	6 in.	8 oz.	2.15
$\frac{5}{16}$ in.	6 in.	10 oz.	2.65
$\frac{3}{8}$ in.	6 in.	12 oz.	3.35

9 T 6712—Set of 6. One each of the sizes listed above. In handy artificial leather case. Shpg. wt. 2 lbs. . . . Set \$12.50

EASY TERMS

Sears Easy Terms make it easy to equip your shop. See inside back cover for complete details.

CRAFTSMAN Drill Grinding Attachment

J There has been a tremendous demand for a moderately priced tool of this type! Now you can repoint your drills with factory accuracy right in your own shop. Drill manufacturers always recommend use of drill grinding attachments and advise avoiding hand grinding. Gives more accurate points.

Precision built with strong, non-rusting die cast aluminum frame. Overall height 7 inches. Designed to give exceptionally accurate adjustments... may be adjusted for all popular drill point angles, including countersinks. It's amazingly easy and simple to operate. Complete easy-to-understand instructions included with each outfit.

Will handle twist drills of the following sizes: $\frac{1}{8}$ -inch to $\frac{3}{4}$ -inch fractional; No. 1 to No. 30 number size; A to Z letter size; 3.0 millimeter to 19.0 millimeter metric size.

9 T 6677—Shipping weight 2 pounds 8 ounces. \$5.25

CRAFTSMAN 5-piece Wood-Carving Tool Set

K A great favorite with professional craftsmen, model makers and hobbyists for carving models, plaques, book ends, jewelry boxes, etc. Also for cutting linoleum, printing blocks, etc. Set includes one $\frac{1}{8}$ -in. bent gouge, one $\frac{3}{16}$ -in. bent chisel, one $\frac{3}{16}$ -in. "U" tool, one $\frac{3}{16}$ -in. straight chisel, and one $\frac{3}{16}$ -inch veining tool. Blades are $2\frac{1}{2}$ in. long, and are forged from high quality heat treated steel that takes and holds a razor-keen edge... will withstand repeated sharpenings. The comfortable $3\frac{3}{4}$ inch smooth-finished hardwood handles have sturdy metal ferrules. The 5-piece set comes packed in special cardboard box. 9 T 2899—Set of 5 tools. Shipping weight 13 ounces. \$3.25

CRAFTSMAN Soldering Irons

L 100-watt specialists' soldering iron. Approved by Underwriters' Laboratories, Inc. For electrical and radio workers who do delicate soldering jobs. $2\frac{1}{2}$ -oz. replaceable insert-type solid copper tip; $4\frac{1}{4}$ in. long. Heat concentrated at point by Nichrome element wound on Allegheny steel core insulated with mica. Hardwood handle. 6-foot insulated cord with plug. For any 110-120 volt current. 9 T 5381—Shpg. wt. 1 lb. 8 oz. . . . Each \$4.25

M 150-watt general purpose soldering iron. Approved by Underwriters' Labs., Inc. $2\frac{1}{2}$ -oz. replaceable insert-type solid copper tip; $4\frac{1}{4}$ inches long. Can be filed to any shape. Nichrome element wound on mica insulated Allegheny steel core, concentrates heat almost instantly at point. 3 cooling fins. Hardwood handle. 6-foot insulated cord with plug. For any 110-120 volt current. 9 T 5382—Shpg. wt. 1 lb. 8 oz. . . . Each \$5.19

N 200-watt heavy duty soldering iron. Approved by Underwriters' Laboratories, Inc. 6-ounce inserted solid copper tip; length $4\frac{1}{2}$ in.; diameter $\frac{5}{8}$ in. Pull out as it wears down. Blunt end for "running" seams. File to any shape. Heat quickly concentrated at point by Nichrome element on mica insulated Allegheny steel core. 3 cooling fins. Hardwood handle. 6-ft. insulated cord with plug. For any 110-120 volt current. 9 T 5383—Shipping weight 1 lb. 8 oz. . . . Each \$5.65

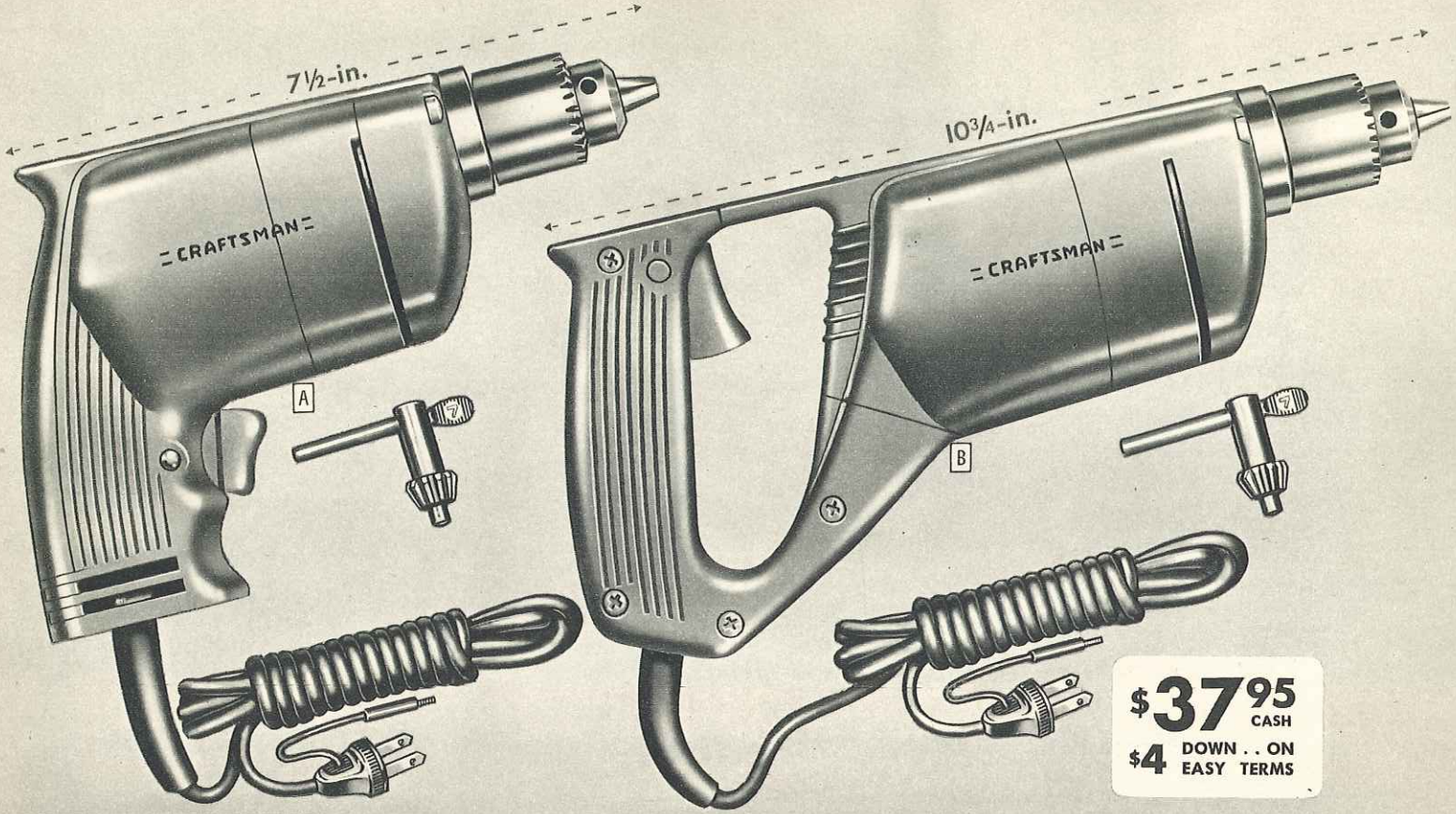

\$37⁹⁵ CASH
\$4 DOWN . . ON EASY TERMS

NEW CRAFTSMAN Heavy Duty Electric Drills

For production duty . . . finest quality and design . . . 1/4-inch capacity

Here's just the drill for those heavy jobs where a compact, lightweight 1/4-inch drill is needed. We believe it is the finest combination of maximum power, lightweight, and compact design of any drill of this type on the market. Built for production line service. Will take the day after day punishment of continuous operation and give trouble-free, long-life service.

Super-powered. Will not stall on the toughest job. Literally packed with power. Accurately balanced power packed universal motor runs smooth and cool.

For 110-120 volt 60 cycle A.C.-D.C. Automatic safety release trigger switch has lock button for continuous running. Underwriters' Laboratories approved.

Excellent design and construction, both inside and out. Strong die cast aluminum frame makes this drill unusually lightweight. Streamlined, compact functional design . . . your choice of easy-to-hold pistol or saw-grip handles.

Equipped with precision ball bearings throughout. Needle roller bearing on chuck spindle. Double re-

duction nickel chrome molybdenum gears give a no-load spindle speed of 1600 R.P.M. Chuck is largest and finest available for drill of this type—heavy duty 1/4-inch Jacobs No. 7B geared key chuck.

Each drill is supplied with 10-foot three-wire rubber covered cord and plug and Jacobs chuck key.

- A 9 T 2570—Pistol grip model. Shipping weight 5 pounds. **\$37.95**
- B 9 T 2571—Saw-grip model. Shipping weight 5 pounds 3 ounces. **37.95**

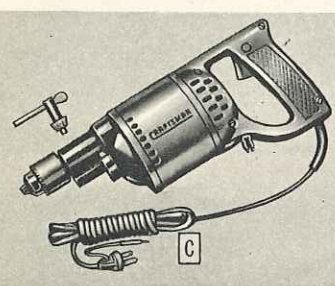

3/8-inch Electric Drill

C CRAFTSMAN heavy duty electric drill built and powered for tough jobs. Aluminum frame. Equipped with heavy duty universal ball bearing motor. Won't stall when used with 3/8-in. drill size. No-load speed 1000 R.P.M. Sealed ball bearings on armature; chuck spindle.

Double reduction gears made of specially heat treated steel. Equipped with No. 32B Jacobs geared key chuck. Has saw grip handle. Underwriters' Laboratory approved trigger switch with lock for continuous running. Over-all length 13 1/2 in. With 10 feet of 3 wire rubber covered cord and plug. For use on 110-120 volt 60 cycle A.C.-D.C.
 9 T 2582—Shpg. wt. 8 lbs. . . . **\$52.95**

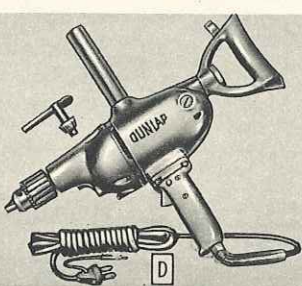

1/2-Inch Electric Drill

D DUNLAP. Ideal utility drill for farmers, garage mechanics and maintenance men. Smooth working; true-running. Plenty of power.

Self-lubricating bronze bearings. Ball thrust bearing on spindle takes up end thrust. Housing of sturdy lightweight aluminum alloy. Handles removable. Underwriters' approved double pole switch locks for continuous running. Double reduction gears of heat treated chrome-nickel steel. 1/2-in. capacity No. 33B Jacobs geared key chuck. Universal motor for 110-120 volt A.C.-D.C. No-load speed 400 R.P.M. Length 16 in. 10-ft. rubber covered cord, plug. Shpg. wt. 14 lbs. 4 oz.
 99 T 02584. **\$37.95**

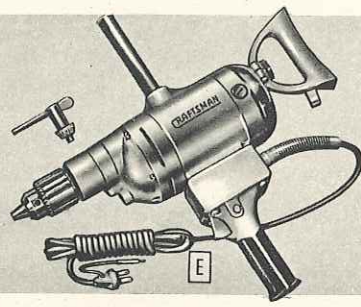

Production-type Drills

E CRAFTSMAN. Perfect electric drill for heaviest duty in shop or factory. New Departure ball bearings are sealed in oil. Jacobs geared key chuck. Underwriters' Laboratories approved double pole switch locks for continuous running. Special triple reduction gears are heat treated chrome-nickel steel. Won't stall when used with drill size specified. Top and rear handle removable. Lightweight aluminum frame.

Extra heavy duty universal ball bearing motor for use on 110-120 volt A.C.-D.C. Overall length 18 1/2 in. With 10-ft. 3-wire rubber covered cord and unbreakable plug.

Catalog No.	Size Drill	R.P.M.	Shpg. wt.	Price
99 T 02585 . . .	1/2-in.	750	27 lbs.	\$64.95
99 T 02586 . . .	5/8-in.	525	30 lbs.	71.95
99 T 02587 . . .	3/4-in.	475	31 lbs.	76.95

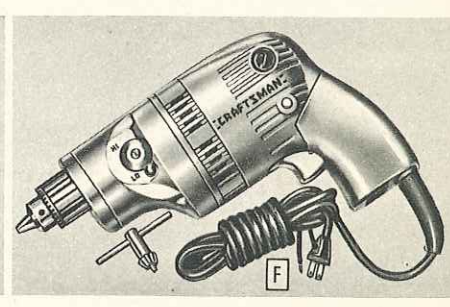

2-speed Electric Drill

F CRAFTSMAN. The right speed for every job with this electric drill. Exclusive convenient gear shift permits change of speed without loss of power. Two speeds—2000 R.P.M. in low gear for general work and 4000 R.P.M. in high gear for high speed drilling—best for small size bits.

Die cast aluminum housing makes it lightweight and easy to handle, yet rugged and sturdy. Precision ball bearing construction. No. 1B Jacobs geared key chuck. Trigger switch; locking button for continuous operation. Fan-cooled universal motor. 110-120 volt A.C.-D.C. Length 10 1/2 in. 10-ft. 3 wire rubber covered cord and plug.
 9 T 2550—Shpg. wt. 5 lbs. . . . **\$39.95**

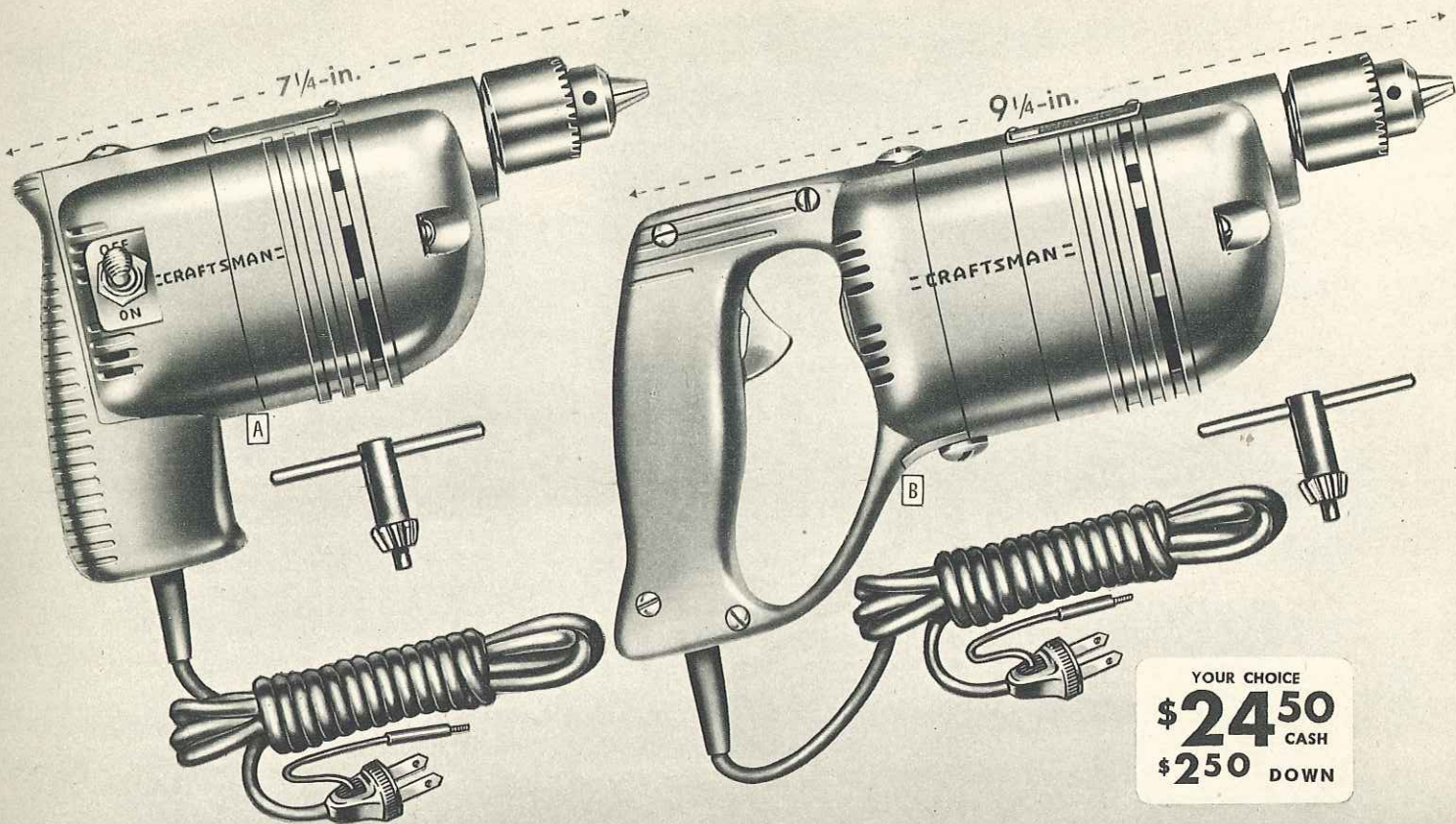

YOUR CHOICE
\$24⁵⁰ CASH
\$2⁵⁰ DOWN

CRAFTSMAN Electric Drills pack lots of power

Weigh less than 3 pounds . . . With 1/4-inch Jacobs geared Key Chuck

Here are the tremendously popular, powerful, small size electric drills that are taking the place of large, heavy, hard-to-handle drills. Why? These CRAFTSMAN electric drills are small . . . light . . . easy to handle . . . easy to use to get into those close places . . . and they are literally power-packed. We couldn't stall one using a 1/4-in. bit on steel plate. The ideal tool for utility or general maintenance use.

Expertly designed and engineered. Lightweight die cast aluminum frame is exceptionally strong for its

weight . . . drill actually weighs less than 3 pounds. Approved by Underwriters' Laboratories Inc.

Precision ball bearings at points of greatest wear—one as thrust bearing, one at gear end of motor. Needle bearing on chuck gear spindle. Gives true-running, trouble-free long life. Equipped with famous No. 1B Jacobs geared key chuck which seats drills firmly yet can be quickly and easily removed.

Double reduction gears are cut from special alloy steel . . . are perfectly meshed for smooth, quiet op-

eration and lower, more practical spindle speed of 1600 R.P.M. Powerful universal motor for use on 110-120 volt 25-60 cycle A.C.-D.C.

Built-in switch. Trigger type on saw-grip model and thumb type on pistol-grip model. Comes with 10 feet of 3-wire rubber covered cord with plug.

- A 9 T 2577—Pistol-grip model. Shipping weight 4 pounds 4 ounces. **\$24.50**
- B 9 T 2578—Saw-grip model. Shipping weight 4 pounds 8 ounces. **24.50**

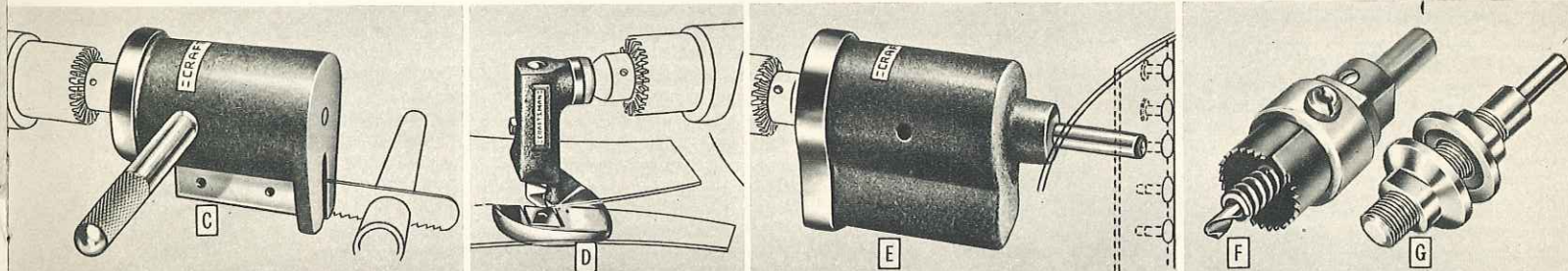

New uses for your 1/4-inch drill with these Accessories

Solid brass cases, with gray wrinkle finish and chromium plated trim. Only two moving parts in each tool; no gears or springs. All working parts made of tool

steel, accurately machined and assembled. For general application on drills from 1600 to 2500 R.P.M. Easily attached. Complete instructions included.

CRAFTSMAN Roto-Vert

C A portable power saw and filing machine when attached to a 1/4-inch electric drill. Ideal for cutting straight or irregular shapes in wood, metal, wall-board, etc. Fine for close quarters and hard-to-get-at places. Uses standard hack saw blades and files. Used by electricians, plumbers, heating and ventilating men; in home and auto repair shops. Length 3 3/8 inches. 9 T 2590—Shpg. wt. 2 lbs. **\$12.50**

CRAFTSMAN Roto-Snip

D Now you can do metal shearing two to three times faster. Eliminates the tiring work of cutting metal with hand snips. Roto-Snip converts 1/4-in. electric drill into a power shears. Cuts sheet metal up to 20-gauge, either straight or circle, down to 1 1/2-inch radius. Scribe lines can be followed easily. Cutting edges easily adjusted and resharpened. Height 3 3/8 inches. 9 T 2591—Shpg. wt. 2 lbs. **\$18.75**

CRAFTSMAN Roto-Pein

E Converts 1/4-in. electric drill into power hammer. Complete with riveting attachment. Length 4 1/4 inches. 9 T 2592—Shpg. wt. 2 lbs. 3 oz. . . . **\$12.50**
 9 T 2595—1/4-inch Concrete Drill. Shipping weight 4 ounces. **79c**
 9 T 2596—5/16-inch Cold Chisel. Shipping weight 3 ounces. **49c**
 9 T 2597—1/2-in. Wood Chisel. Shipping weight 3 ounces. **79c**
 9 T 2598—5/16-inch Center Punch. Shipping weight 3 ounces. **49c**
 9 T 2599—Set of two 5/16-inch tool steel blanks. Shpg. wt. 3 oz. **49c**

Electric Drill Attachments

F Circular Hole Saw for electric drills. Finest heat treated high speed steel. Cut clean, round holes in wood or metal. Depth of cut 1/2 inches. Use 1/2-inch drill or larger. Comes complete with mandrel. Please state size wanted.

Size, in.	3/4	1	1 1/4	1 1/2	2	2 1/2
Shpg. wt.	8 oz.	9 oz.	14 oz.	15 oz.	1 lb. 4 oz.	1 lb. 6 oz.
9 T 2698	\$3.69	\$3.69	\$3.69	\$3.69	\$4.10	\$4.59

Saw Blade only for circular hole saw

Size, in.	3/4	1	1 1/4	1 1/2	2	2 1/2
Shpg. wt.	5 oz.	6 oz.	8 oz.	9 oz.	12 oz.	15 oz.
9 T 2697	89c	89c	89c	89c	\$1.29	\$1.79

G Arbor for electric drill. For holding grinding wheels, wire wheels, buffing wheels, etc. 1/2-inch shank. Arbor is 1/2-inch by 20 thread. 3 5/16 inches long. 1 1/4-inch flanges with nuts, in one piece. Precision made of carbon steel. 9 T 2594—Shipping weight 6 ounces. **49c**

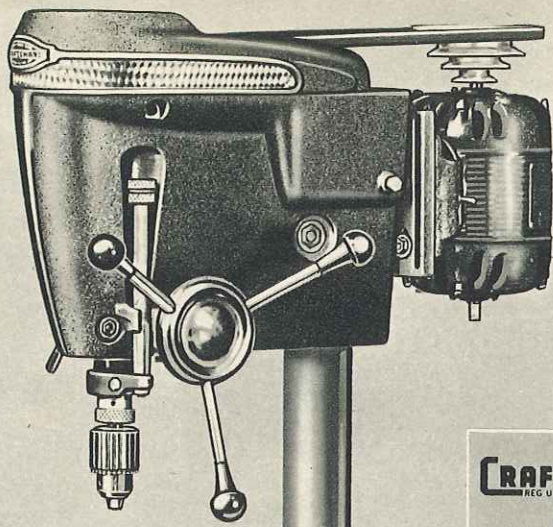

\$108.50 with motor

A
With-
out
Motor **\$81.00** CASH
\$85.00 DOWN . . ON
EASY TERMS

CRAFTSMAN
REG. U.S. PAT. OFF.

THE RIGHT WAY
TO SAY

**HARDWARE
AND TOOLS**

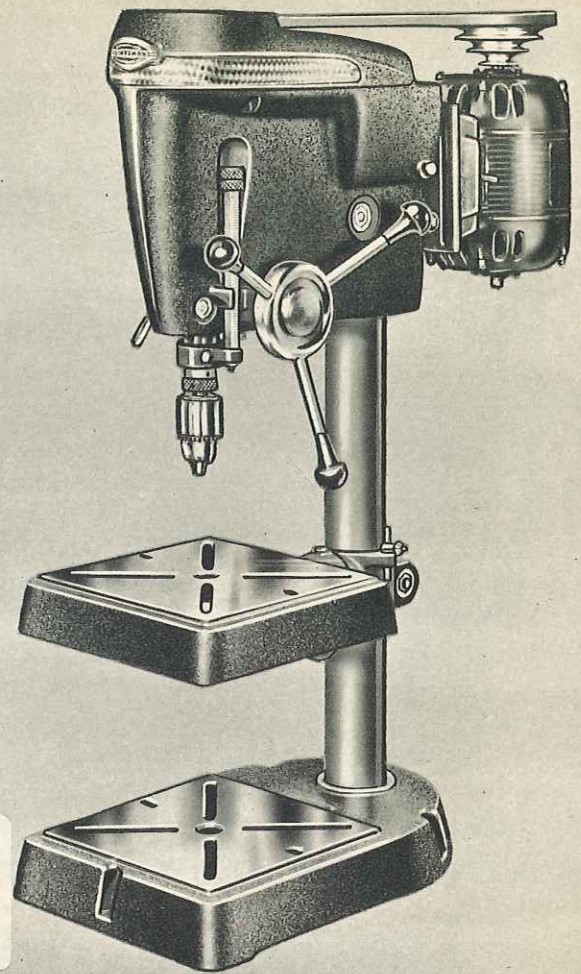

\$100.00 with motor

B
With-
out
Motor **\$72.50** CASH
\$75.00 DOWN . . ON
EASY TERMS

CRAFTSMAN heavy duty type

Drills to the center of 15-inch circle

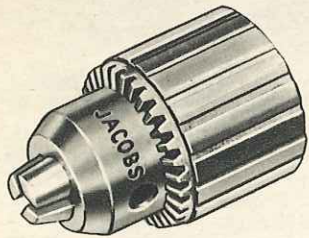

Jacobs No. 6A-33 Chuck for use with No. 33 Jacobs Taper Arbor supplied with CRAFTSMAN "100" Drill Presses. Capacity 0 to 1/2 inch. Precision made.

CRAFTSMAN "100" heavy duty Drill Press. Packed with power and capacity. Gives accuracy in operation not found in others several times the cost. Notice the modern designed streamlined head . . . no unsightly spindle extending above head . . . easy-acting three lever feed handle. This drill press will give you superb performance on those steady day-in day-out production jobs.

Perfect accuracy. You'll be able to do work that's accurate to the thousandths of an inch. The table is held in perfect alignment at 0 degrees by a taper pin. Absolutely prevents table from tilting even a fraction of an inch. Pin is removable for tilting table from 0 to 90 degrees right or left.

Double-acting shoe locks. Securely lock head to column, table to column and quill. Precision made . . . keeps table, column and head in perfect alignment. Operated by convenient handles on the side.

New spiral coil spring for quill return practically eliminates breakage. Quill return shock absorbed by rubber cushion. Pre-loaded ball bearings in quill. Extra long quill support in head casting. Has famous "Floating Drive" spindle assembly. Spindle has No. 33 Jacobs taper. Built-in holder for chuck key.

SPECIFICATIONS:	99 TM 2313	99 TM 2314
• Depth of throat	7 3/4 inch	7 3/4 inch
• Spindle	No. 33 Jacobs Taper	No. 33 Jacobs Taper
• Bearings	4 heavy duty ball	4 heavy duty ball
• Chuck capacity (Jacobs 6A-33) . . .	0 to 1/2 inch	0 to 1/2 inch
• Spindle travel	4 inches	4 inches
• Depth gauge, graduations	1/16 of an inch	1/16 of an inch
• Column diameter (outside)	2 3/4 inches	2 3/4 inches
• Table size	10x10 inches	10x10 inches
• Table travel	13 3/32 inches	41 1/32 inches
• Distance table to chuck, maximum	13 3/32 inches	41 1/32 inches
• Distance base to chuck, maximum	17 3/8 inches	45 5/8 inches
• Machine and motor pulley (in- cluded)	5 in. 4 step	5 in. 4 step
• Motor recommended, minimum . . .	1/2 H.P. 1750 RPM	1/2 H.P. 1750 RPM
• 11 speeds from	625 to 5000 RPM	625 to 5000 RPM
• Mounting dimensions	9 1/2 x 14 1/2 inches	16 1/2 x 14 1/2 inches
• Overall dimensions: Height	36 3/8 inches	68 3/8 inches
Width	12 7/8 inches	18 1/8 inches
Depth	19 inches	24 inches

A 99 TM 2314—Floor model without motor. Shipping weight 194 lbs. . . . **\$81.00**

99 TM 2331—Floor model with 1/2 H.P. 1750 R.P.M. capacitor ball bearing, 110-120-volt 60 cycle A. C. motor. Shipping weight 229 pounds. **\$108.50**

B 99 TM 2313—Bench model without motor. Shipping weight 135 lbs. **72.50**

99 TM 2330—Bench model with 1/2 H.P. 1750 R.P.M. capacitor ball bearing 110-120-volt 60 cycle A. C. motor. Shipping weight 170 pounds. **\$100.00**

Available with motors

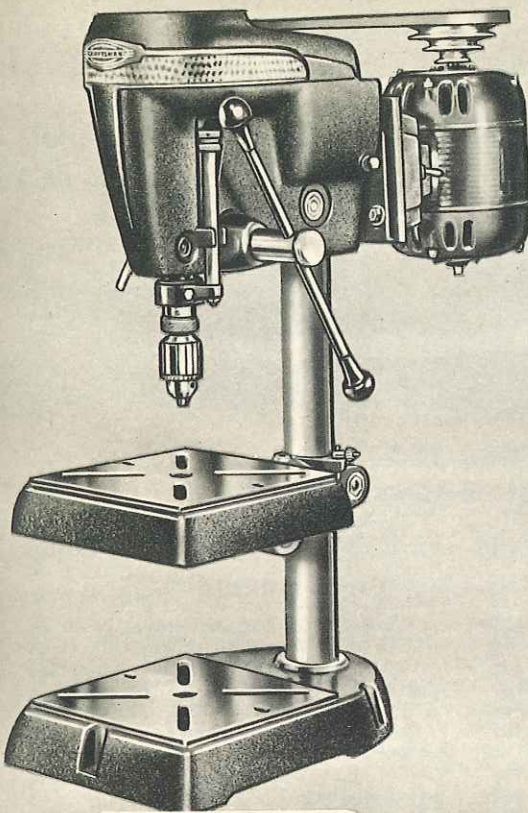

A Without Motor **\$62.00** CASH
\$6.50 DOWN ON TERMS
 \$89.50 with motor

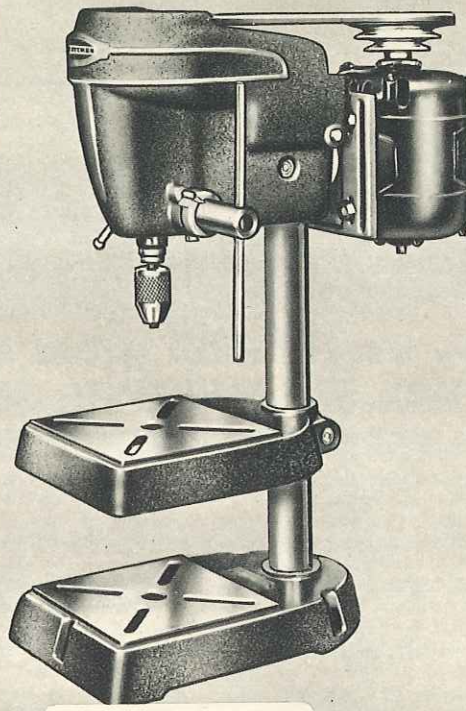

B Without Motor **\$36.50** CASH
 99 TM 2310
\$4 DOWN . . ON TERMS
 \$55.00 with motor

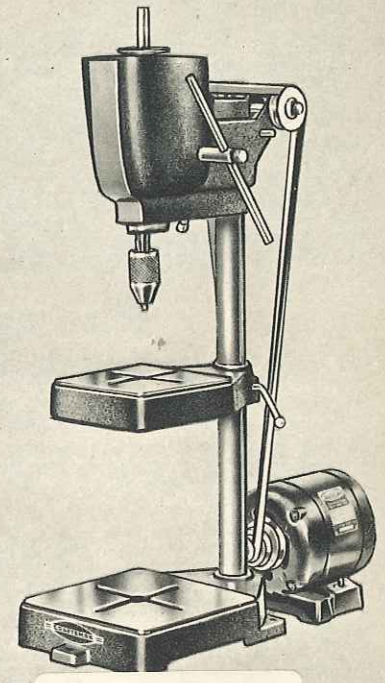

C Without Motor **\$21.50** CASH
\$2.50 DOWN ON TERMS
 \$40.00 with motor

CRAFTSMAN Drill Press . . new 1948 models

REG. U.S. PAT. OFF.

Ball bearing Drill Press

A It's the CRAFTSMAN "100". The sturdy, rugged drill press for your wood and metal work. Designed to give utmost accuracy. Notice that the spindle does not project above head . . . Sears new modern, compact, streamlined design. It's a beauty.

Drills to center of 13 1/2-inch circle. Maximum spindle travel 3 1/2 inches. Adjustable stop collar with lock can be set for repetitive drilling.

Perfectly aligned table. Tapered pin holds the 9x9-inch table on support in perfect alignment at horizontal position. Table can be tilted 0 to 90 degrees either right or left. Made of smooth ground cast iron.

Coil spring for quill return. Practically eliminates breakage. Rubber cushion absorbs quill shock. Long quill support in head casting. Quick-acting double shoe quill lock. "Floating Drive" spindle assembly gives smoother operation. Sliding feed handle easily adjusted.

SPECIFICATIONS:

- Depth of throat 6 1/2 inches
- Spindle No. 33 Jacobs taper
- Bearings 4 heavy duty ball
- Chuck capacity 0 to 1/2 inch
- Spindle travel 3 1/2 inches
- Depth gauge graduations 1/16 inch
- Outside column diameter 2 1/4 inches
- Table size 9x9 inches
- Table travel 10 5/16 inches
- Table to chuck, maximum 10 5/16 inches
- Base size 11x16 3/4 inches
- Base to chuck, maximum 14 3/8 inches
- Machine and motor pulley (included) 5 in. 4 step V-Cone type
- Motor recommended, minimum . . . 1/2 HP. 1750 R.P.M.
- Eleven speeds 625-5000 R.P.M.
- Mounting dimensions 8 5/8 x 12 1/4 inches
- Overall dimensions: Height 31 3/8 inches; width 11 1/2 inches; depth 16 3/8 inches.

99 TM 2364—Without motor. Shpg. wt. 107 lbs. . . \$62.00
 99 TM 2366—With 1/2-H.P. 1750 R.P.M. capacitor 110-120-volt 60-cycle A.C. ball bearing motor. Shpg. wt. 142 lbs. \$89.50

Bronze bearing Drill Press

B CRAFTSMAN "80" . . . one of our lower priced drill presses. Ideal for drilling operations in smaller shops. Efficient work can be done on either wood or metal.

Drills to center of 12 1/4-inch circle. Spindle travel 3 inches. Runs on three long-life, self-lubricating oilite bronze bearings; ball thrust bearing absorbs spindle thrust. Adjustable stop collar for repetitive drilling.

Famous "Floating Drive" spindle assembly. Eliminates "whip"; absorbs belt pull. New improved spiral coil spring quill return. Rubber cushion absorbs quill return shock. Feed lever handle quickly adjusted for greater leverage. 7 3/4-inch square table. Provides ample working surface. Table is non-tilting.

SPECIFICATIONS:

- Depth of throat 6 1/2 inches
- Spindle 1/2-20 thread or No. 33 Jacobs Taper
- Bearings 1 ball thrust; 3 porous bronze
- Chuck capacity 0 to 1/2 in. or Jacobs 5/8 to 1/2 in.
- Spindle travel 3 inches
- Outside diameter of column 1 1/2 inches
- Table size 7 3/4 x 7 3/4 inches
- Table travel 8 3/8 inches
- Table to chuck (maximum) 8 3/8 inches
- Base size 9x14 inches
- Base to chuck (maximum) 11 1/2 inches
- Machine and motor pulley (included) . . . 4 inch 4 step
- Motor recommended, minimum . . . 1/2 H.P. 1750 R.P.M.
- Eleven speeds 750 to 4000 R.P.M.
- Mounting dimensions 7 5/8 x 11 1/8 inches
- Overall dimensions: Height 26 3/4 inches; width 10 1/2 inches; depth 15 1/2 inches.

Three-jaw self-centering chuck and V-belt are included.
 99 TM 2310—Without motor. Shpg. wt. 75 lbs. . . \$36.50
 99 TM 2311—With 1/4 H.P. 1750 R.P.M. split phase 110-120-volt A.C. ball bearing motor. Shpg. wt. 105 lbs. \$55.00
 99 TM 2362—Similar to 99 TM 2310 above but equipped with No. 33 Jacobs tapered spindle and No. 33 Jacobs key chuck 3/4 to 1/2 inch capacity. Shpg. wt. 77 lbs. . . \$41.50
 99 TM 2363—Same as 99 TM 2362 with 1/2 H.P. 1750 R.P.M. split phase 110-120-volt A.C. motor. Shpg. wt. 107 lbs \$60.00

Low priced Drill Press

C This CRAFTSMAN "40" has the same rugged construction and quality as our other CRAFTSMAN Drill Presses but is built for smaller utility. You can now have a good low priced drill press in your hobby or small work shop. Can be used for drilling wood or metal.

Drills to center of 9-inch circle. Maximum spindle travel 1 1/8 inches. Equipped with top quality self-lubricating oilite bronze bearings.

Adjustable head, table and idler drive.

SPECIFICATIONS:

- Depth of throat 4 1/2 inches
- Spindle 1/8-20 thread
- Bearings 3 porous bronze, 1 ball thrust
- Chuck capacity 0 to 3/8 inch
- Spindle travel 1 1/8 inches
- Outside column diameter 1 1/2 inches
- Table size 5 1/2 x 5 1/2 inches
- Table travel 10 1/8 inches
- Table to chuck, maximum . . . 10 1/8 inches
- Base size 6x6 inches
- Base to chuck, maximum . . . 11 1/2 inches
- Machine pulley (included) . . . 3/8 inch; 3-inch 3-step Cone "V" type
- Motor pulley (not included) . . . 3 inch, 3-step Cone "V" type
- Motor recommended, minimum . . . 1/4 H.P. 1750 R.P.M.
- Belt (not included) . . . 3/8-inch wide; 50 in. long.
- Seven speeds . . . 1150 to 3450 R.P.M.
- Mounting dimensions . . . 8x6 1/4 inches
- Overall dimensions: Height 24 5/8 inches; depth 13 1/4 inches; width 7 1/8 inches.

99 TM 2172—Without motor. Shipping weight 26 pounds. \$21.50
 99 TM 2166—With 1/4 H.P. 1750 R.P.M. split phase, ball bearing, 110-120-volt 60-cycle A.C. motor. Shipping weight 55 pounds. \$40.00

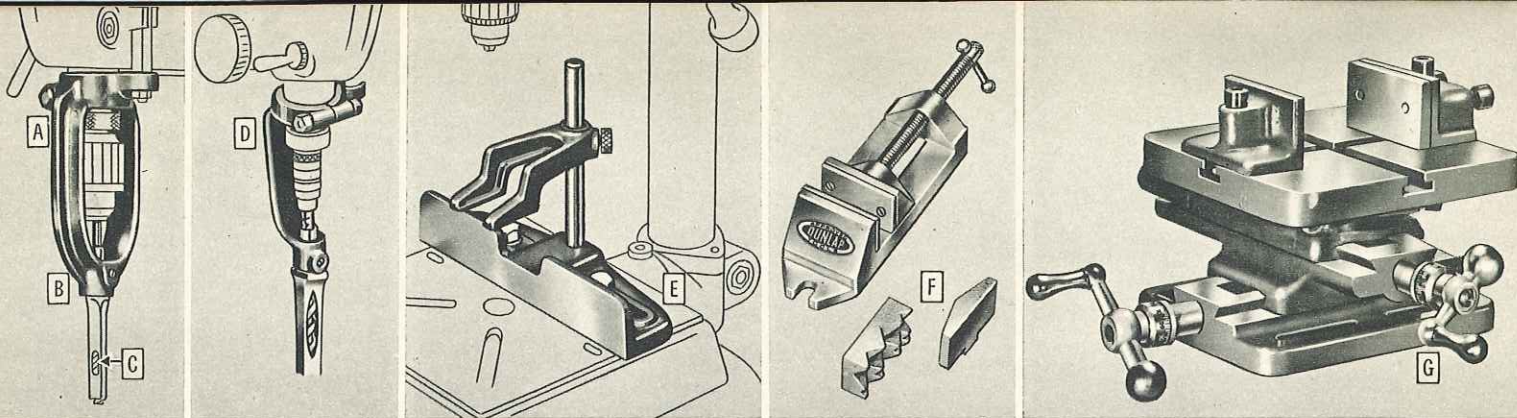

Fine quality, useful drill press accessories . . .

Mortising Chisel Housing

CRAFTSMAN. Cut square holes with your drill press. Housing mounts on quill. Bit drills round hole; hollow chisel trims corners square. Makes your drill press a mortising machine that cuts clean, accurate mortise joints. A great aid to woodworkers.

A 9 T 2467—Mortising Chisel Housing. For drill presses 99TM2314 and 99TM2313 (page 28 and 99TM2364 (page 29). Use with 9T2420 and 9T2422 (listed below) or almost any hollow chisel and mortising bit. Shpg. wt. 3 lbs. . . . \$3.85

B 9 T 2461—Mortising Chisel Housing. For former CRAFTSMAN drill presses Nos. 2380, 2407, 2423 and 2392. Use with 9T2420 and 9T2422 (listed below) or almost any hollow chisel and mortising bit. Shpg. wt. 3 lbs. . . . \$2.95

C 9 T 2420—Hollow Chisel. For 9T2467 and 9T2461 (listed above). $\frac{1}{4}$, $\frac{3}{8}$ and $\frac{1}{2}$ -inch. Please state size. Shipping weight 4 oz. . . . \$3.49

D 9 T 2422—Mortising Bit. For 9T2420 (listed above). $\frac{1}{4}$, $\frac{3}{8}$ or $\frac{1}{2}$ -inch. Please state size. Shipping weight 4 ounces. . . . \$2.05

Hold-down Guide

E CRAFTSMAN. Made to fit almost any drill press table. Indispensable in mortising or repetitive drilling. Fingers on hold-down prevent work from being lifted when chisel or drill is raised. Easily adjustable for thick or thin materials. Fence keeps work lined up. Attachment bolts to drill press table; may be adjusted forward or backward simply by loosening bolts. Fence section can also be used without hold-down to serve as guide in routing, inlay work, repetitive drilling and similar operations. Durable heavy cast iron construction. Shipping weight 6 lbs. 6 oz. 9 T 2457 \$4.95

Drill Press Vise

F Insures accuracy by holding work firmly in position while it is being drilled or worked on. Increases the range of work your drill will handle. Makes working with small pieces more convenient. Strong, accurately cut steel screw; knurled end; sliding handle. Base of non-ferrous metal. $2\frac{3}{4}$ -inch cast iron jaws with steel faces; open 3 inches. Over-all length of vise $10\frac{1}{2}$ inches. Complete with 2 extra jaws: one for round or irregular work and one for tapered pieces. Shipping wt. 4 lbs. 9 T 2436 \$3.25

CRAFTSMAN Drill Press Milling Vise

G Use this drill press milling vise to increase the usefulness of your drill press! This versatile accessory enables you to handle all types of accurate drilling, layout and spacing work—straight lines, radial and circular work; also light milling. Can also be used with shaper, lathe or grinder for any jobs in which accurate feeds in two directions are required. Bolts on drill press table. The work is locked on the table between two adjustable jaws. By use of the two cross feed controls, work may be moved to any desired horizontal position. Base is graduated through 180 degrees so vise table may be rotated to any angle and set accurately. Table is 7×7 inches. Travel on both cross feeds is 6 inches. Capacity of vise $3\frac{1}{2}$ inches. Husky jaws are 3 inches wide; $1\frac{1}{2}$ inches high. Dovetailed ways assure smooth, accurate operation at all times. Complete with wrench. 99 T 02432—Shipping weight 18 lbs. \$35.50

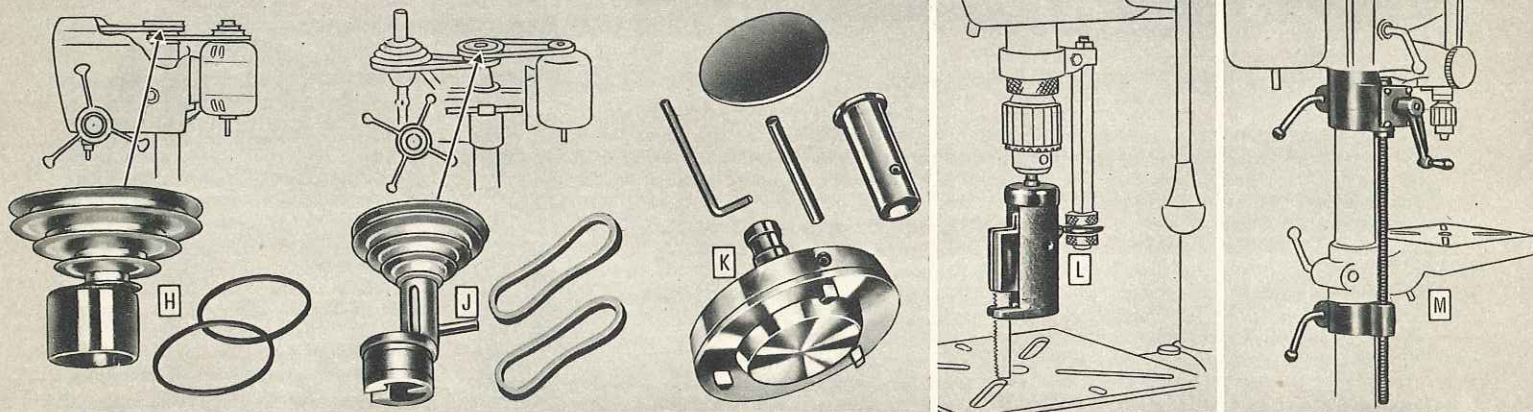

Multi-Speed Attachments

CRAFTSMAN. Use the correct speed for every job! Slow speeds for drilling metal; high speeds for woodworking and routing. Give 20 speeds from 200 R.P.M. to about 15,000 R.P.M. Easily installed. Finest ball bearing construction. Balanced pulley. Two V-belts included. We recommend use of $\frac{1}{2}$ -H.P. 1750 R.P.M. motor minimum to secure high speeds. Shipping weight each 5 lbs.

H 9 T 2338—Fits 99 TM 2364, 99 TM 2313 and 99 TM 2314. (see pages 28 and 29) 2312 and some other drill presses with 2 or $2\frac{3}{8}$ -inch (plus .005-inch) inside diameter columns. \$11.25

9 T 2399—(Not illus.) Fits drill presses 2482, 2483 and others with $2\frac{3}{8}$ -inch (plus .005-inch) inside diameter columns. \$9.75

J 9 T 2394—Fits former drill presses Nos. 2407, 2392, 2423 and others with $2\frac{3}{8}$ -inch (plus .005-inch) inside diameter columns. \$9.75

9 T 2397—(Not illus.). Fits drill press No. 2380 and others with 2-inch (plus .005-inch) inside diameter columns. \$9.75

Barron Rotary Planer

K Five tools in one! Does routing, planing, rabbeting and paneling. Dresses, trues-up and finishes all types of wood. Won't burn, gouge or scratch. Will plane and resurface 12×28 -inch board in 45 to 60 seconds! Fits any drill press with $\frac{1}{2}$ -inch chuck capacity. Adapter for Jacobs No. 3 taper spindle is included.

Diameter 3 in.; $\frac{1}{2}$ -in. round arbor. Special molybdenum tungsten tool steel blades. Set includes: Allen wrench, set-up gauge, push-down pin and instructions. (Shpg. wt. 1lb. 11 oz.) 9 T 2289—Postpaid. Complete set \$7.50

Barron Planer Blade Holder. (Not shown). For resharpening planer blades at correct angle. Made of steel. With instructions. (Shipping weight 3 oz.) 9 T 2280—Postpaid. Each 75c

9 T 2281— $\frac{3}{4}$ -inch long Replacement Blades. Postpaid. (Shpg. wt. 1 oz.) \$3 for \$1.75

Spindle Adapters for screw-on chuck drill presses. Postpaid. (Shpg. wt. 6 oz. each.) 9 T 2254— $\frac{1}{4}$ -in. 20 thread spindle. . . . \$1.50 9 T 2251— $\frac{1}{2}$ -in. 24-thread spindle. . . . 1.50

Roto-Vert Senior

L CRAFTSMAN. For drill press and electric hand drills having a chuck capacity of $\frac{3}{8}$ -inch or greater. Easily attached to drill presses having depth gauges as illustrated. Converts your electric drill or drill press into a power sawing and filing machine. Uses standard hack saw blades and files. Look what you can do with Roto-Vert Senior! You can cut straight or irregular shapes in wood, metal, wall-board, etc. Very useful to plumbers, electricians, heating and ventilating men, home and auto repair shops.

Note its sturdy, long-life construction! Only two moving parts . . . and they're both made of tough, wear-resistant tool steel. No gears or springs to break or get out of order! All parts accurately machined and assembled. Solid brass case has gray wrinkle finish; contrasting chromium plated trim. Length $5\frac{7}{16}$ in. Complete instructions. 9 T 2600—Shpg. wt. 2 lbs. 13 oz. \$13.95

Head and Table Lift

M For CRAFTSMAN 99 TM 2314 and many other floor model drill presses with $2\frac{3}{4}$ -inch outside diameter columns. For fast, easy raising or lowering of drill press head or table. Support collars for drill head and table are positioned by Acme-threaded lift screw with bevel-gear drive controlled by handy crank handle. Both support collars have co-ordinate clamp locks. When head support collar is tightened, lower collar may be loosened for raising or lowering table. Similarly, when table collar is tightened, it serves as support for positioning drill press head.

Each turn of crank gives $\frac{1}{4}$ -inch travel. Maximum travel at any one setting is 12 inches. Two bevel gears, thrust bearing and crankshaft are all housed in gear case which is cast in one piece with the upper support collar. Ball thrust bearing absorbs the load on the screw. 99 T 02419—Shpg. wt. 18 lbs. \$19.00

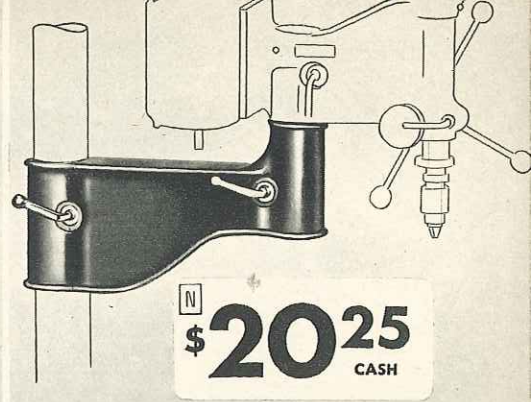
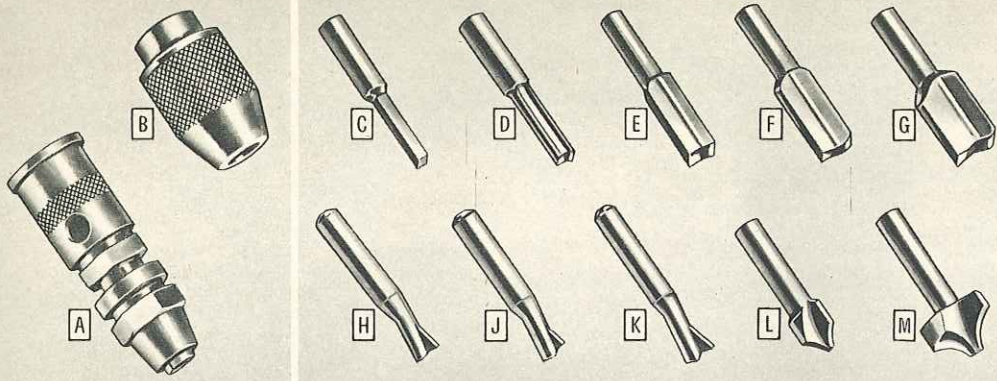

...increase the usefulness of your drill press

Collet Chucks

- A** For cutters at right or any $\frac{1}{4}$ or $\frac{1}{2}$ -in. diam. spindle. $\frac{1}{2}$ -in. capacity with $\frac{1}{4}$ -in. bushing. Fits any drill press with No. 33 Jacobs taper spindle. Replaces key chucks on any work developing side thrust, as in routing. Drill press collar holds chuck securely. Shpg. wt. 8 oz. 9 T 2455.....\$1.33
- B** Screw-on type collet chuck. $\frac{1}{4}$ -in. capacity. Use with cutters at right. Fits drill press or any spindle having $\frac{1}{4}$ -in. x 20 thread (see 9T2310 and 9T2172, page 29). Shpg. wt. 3 oz. 9 T 2271.....95c

Tool steel Bits for routing, dovetailing and carving

Make your drill press more useful with a complete set of tool steel cutters that permit you to do accurate carving, round-end mortising, dovetailing, boring, round edging reeding and general routing. These handy drill press accessories are precision made of the finest quality high speed tool steel; carefully ground for keen, long lasting edges. All cutters are perfectly ground to exact dimensions. They are fast, free, clean and smooth cutting. All have $\frac{1}{4}$ -inch shanks. Use with either 9T2455 or 9T2271 collet chucks shown at left on this page. Routing bits are used most efficiently when work is held against a fence to obtain parallel and accurate routing (see Sears 9T2457 Hold-down Guide, on opposite page). **Caution: Use these cutters in collet chucks only—Never in Jacobs or other three jaw drill chucks!**

- | | |
|--|---|
| C 9 T 2400— $\frac{1}{8}$ -inch router. Shipping weight 6 ounces..... | H 9 T 2409— $\frac{1}{4}$ -inch dovetail router. Shipping weight 6 oz..... |
| D 9 T 2401— $\frac{1}{4}$ -inch router. Shipping weight 6 ounces..... | J 9 T 2410— $\frac{3}{8}$ -inch dovetail router. Shipping weight 6 oz..... |
| E 9 T 2402— $\frac{3}{8}$ -inch router. Shipping weight 6 ounces..... | K 9 T 2411— $\frac{1}{2}$ -inch dovetail router. Shipping weight 6 oz..... |
| F 9 T 2403— $\frac{1}{2}$ -inch router. Shipping weight 6 ounces..... | L 9 T 2415— $\frac{1}{2}$ -inch carving router. Shipping weight 6 oz..... |
| G 9 T 2404— $\frac{5}{8}$ -inch router. Shipping weight 6 ounces..... | M 9 T 2416— $\frac{3}{4}$ -inch carving router. Shipping weight 6 oz..... |

Drill Press Radial Arm

N With this radial arm you will more than double the capacity of your drill press. It increases the distance from main column to chuck to 24 inches. Enables you to drill to center of a 48-inch circle. Can be swung to almost any position. When used in conjunction with column collar, arm can be left loose on column and head swung about for routing and similar operations. Permits drill head to be mounted above or below arm.

Ideal for patternmakers and similar shops needing capacity for large work. Extra heavy casting of rugged construction provides necessary great rigidity. Co-ordinate clamps lock arm rigidly to column. Can be used only with floor type drill press having a $2\frac{1}{4}$ -inch outside diameter column, such as 99 TM 2314 drill press on page 28. Shipping weight 35 pounds. 99 T 02418.....\$20.25

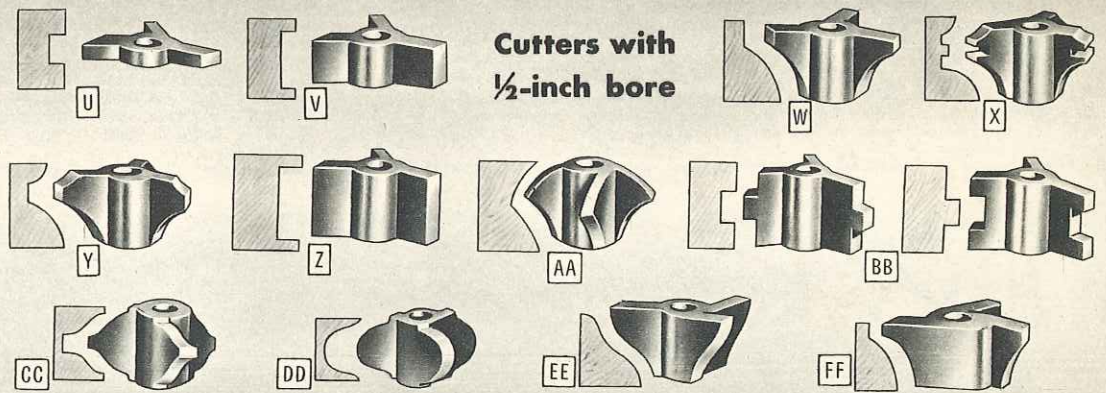
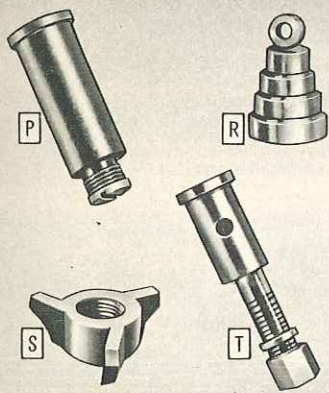

Cutters with $\frac{1}{2}$ -inch bore

Adapters and Cutters

- P** Adapter for 9T2438 sash cutter below. Fits spindles of CRAFTSMAN drill presses 9T2362, 9T2364, 9T2313 and 9T2314 (see pages 28 and 29), or any drill press with No. 33 Jacobs taper spindle and knurled locking collar to hold adapter flange securely. 9 T 2437—Shipping weight 7 ounces.....\$1.35
- R** Sash Cutter. Threaded for use with adapter 9T2437 above. 9 T 2438—Shipping weight 4 ounces.....\$2.39
- S** Shaper Collars. Mount beneath shaper cutters to control depth of cut on curved work. Fit $\frac{1}{2}$ -inch spindle. 9 T 2367—Shipping weight 6 ounces...set \$1.80
- T** Adapter for all $\frac{1}{2}$ -inch bore shaper cutters shown at right. Fits spindles of CRAFTSMAN drill presses 9T2362, 9T2364, 9T2313 and 9T2314 (pages 28 and 29), or any drill press with No. 33 Jacobs tapered spindle and knurled locking collar. 9 T 2435—Shipping weight 7 ounces.....\$1.29

Shaper Cutters that form almost any contour

These high speed cutters will add tremendous usefulness to your drill press. They permit almost any kind of contour to be formed quickly and accurately... do many types of shaping work. Made of finest quality special alloy tool steel; carefully hardened and ground

for keen, long lasting edges. Precision machined and ground to exact dimensions... they give an accurate, fast, clean, smooth cutting action. Cutters have $\frac{1}{2}$ -inch bore. Use with adapter 9T2435, at left. May be sharpened by grinding front face on flat, fine grit wheel.

- | | |
|--|--|
| U 9 T 2319— $\frac{1}{4}$ -inch high; $\frac{1}{8}$ -inch radius. Shipping weight 6 ounces..... | BB A complete matched set of tongue and groove cutters to be used in connection with your drill press or shaper. Precision ground and matched for accurate fit to give a clean, smooth joint at all times. $\frac{1}{2}$ -inch bore; 1-inch high; $\frac{1}{8}$ -inch radius. 9 T 2365—Shipping weight 10 ounces..... |
| Each \$1.42 | Set \$3.85 |
| V 9 T 2321— $\frac{1}{2}$ -inch high; $\frac{1}{8}$ -inch radius. Shipping weight 6 ounces..... | CC 9 T 2345—Large size cutter. 1-inch high; $1\frac{1}{4}$ -inch radius. Shpg. wt. 8 oz.. |
| Each 1.70 | Each 2.85 |
| W 9 T 2323—1-inch high; $\frac{1}{8}$ -inch radius. Shipping weight 6 ounces..... | DD 9 T 2346—Large size cutter. 1-inch high; $1\frac{1}{4}$ -inch radius. Shpg. wt. 8 oz.. |
| Each 2.00 | Each 2.85 |
| X 9 T 2327—1-inch high; $\frac{1}{8}$ -inch radius. Shipping weight 6 ounces..... | EE 9 T 2347—Large size cutter. 1-inch high; $1\frac{1}{4}$ -inch radius. Shpg. wt. 8 oz.. |
| Each 2.00 | Each 2.85 |
| Y 9 T 2329—1-inch high; $\frac{1}{8}$ -inch radius. Shipping weight 6 ounces..... | FF 9 T 2348—Large size cutter. 1-inch high; $1\frac{1}{4}$ -inch radius. Shpg. wt. 8 oz.. |
| Each 2.00 | Each 2.85 |
| Z 9 T 2333—1-inch high; $\frac{1}{8}$ -inch radius. Shipping weight 6 ounces..... | |
| Each 1.95 | |
| AA 9 T 2335—1-inch high; $\frac{1}{8}$ -inch radius. Shipping weight 6 ounces..... | |
| Each 2.00 | |

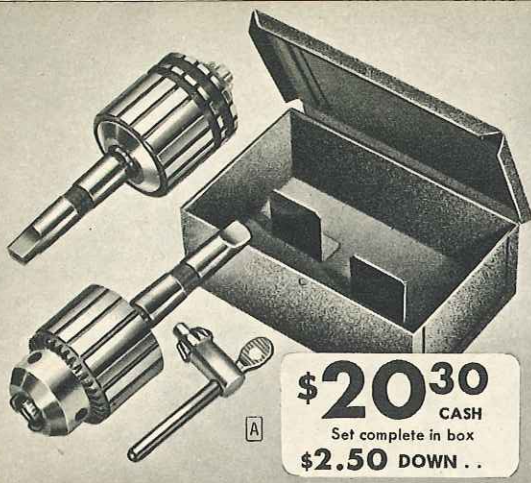

\$20³⁰ CASH
Set complete in box
\$2.50 DOWN

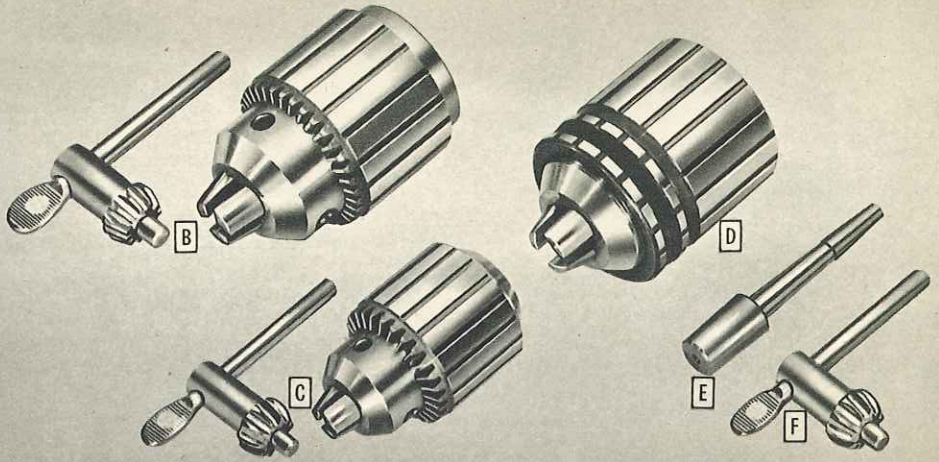

Jacobs Chucks for drill presses, lathes, electric drills, etc.

Genuine Jacobs chucks and arbors, nationally famous for their correct design, excellence of materials and precision manufacture. *All Jacobs chucks and accessories described on this page are postpaid*

Jacobs Commutator Kit

A For holding armature shafts rigidly during reconditioning. Kit includes: No. 75A armature driving chuck; No. 100 center rest chuck ($\frac{1}{4}$ to $\frac{3}{8}$ -inch capacity); two arbors (No. 2 Morse taper, shank end; No. 3 Jacobs taper head end); chuck key. Kit comes complete in strong metal box.
9 T 2129—Postpaid. (Shipping weight 7 pounds 4 ounces)..... **\$20.30**

Jacobs Headstock Chucks

B 9 T 2044—Jacobs No. 55B. Capacity 0 to $1\frac{1}{2}$ in. Fits only 1-in. 8-thread spindle. Cannot be used with any type of arbor. Postpaid. (Shipping weight 3 pounds 10 ounces)..... **\$12.00**
9 T 2144—Jacobs No. 58B. Capacity $\frac{1}{8}$ to $\frac{3}{8}$ inch. Fits $1\frac{1}{2}$ -inch, 8-thread spindle. Can also be used with No. 3 Jacobs taper arbor. Postpaid. (Shipping weight 3 pounds 12 ounces)..... **\$15.00**
9 T 2121—Jacobs No. 59B. Capacity $\frac{3}{16}$ to $\frac{3}{4}$ inch. Fits only $1\frac{1}{2}$ -inch 8-thread spindle. Cannot be used with any type of arbor. Postpaid. (Shipping weight 5 pounds 8 ounces)..... **\$18.00**

Jacobs Drill Chucks for No. 33 Jacobs Taper Arbor

C 9 T 2142—Jacobs No. 33 Key-type chuck. Fits arbors with No. 33 Jacobs taper. Capacity $\frac{5}{64}$ to $\frac{1}{2}$ inch. Postpaid. (Shpg. wt. 1 lb. 8 oz.)..... **\$6.50**
9 T 2143—Jacobs No. 6A-33 key-type chuck. Fits arbors with No. 33 Jacobs taper. Capacity 0 to $\frac{1}{2}$ inch. Postpaid. (Shpg. wt. 2 lbs. 8 oz.)..... **7.50**

Jacobs Center Rest Chuck

D 9 T 2991—Jacobs No. 100CR. Capacity $\frac{1}{4}$ to $\frac{3}{4}$ inch. Must be used with No. 3 Jacobs taper arbor to support centerless armatures, etc. Postpaid. (Shipping weight 3 pounds 2 ounces)..... **\$10.00**

Jacobs Chuck Arbors

Precision ground... extremely accurate... to insure maximum accuracy of machine spindle and chuck performance.

E Jacobs chuck arbors to fit 9 T 2142 and 9 T 2143 chucks, listed at left.
9 T 2131—No. 0 Morse taper and No. 33 Jacobs taper. Postpaid. (Shipping weight 8 ounces)..... **85c**
9 T 2123—No. 1 Morse taper and No. 33 Jacobs taper. Postpaid. (Shipping weight 10 ounces)..... **85c**
9 T 2124—No. 2 Morse taper and No. 33 Jacobs taper. Postpaid. (Shipping weight 14 ounces)..... **85c**
For 9 T 2129, 9 T 2144 and 9 T 2991 Jacobs chucks, listed at left.
9 T 2133—No. 0 Morse taper and No. 3 Jacobs taper. Postpaid. (Shipping weight 10 ounces)..... **85c**
9 T 2154—No. 1 Morse taper and No. 3 Jacobs taper. Postpaid. (Shipping weight 12 ounces)..... **85c**
9 T 2126—No. 2 Morse taper and No. 3 Jacobs taper. Postpaid. (Shipping weight 14 ounces)..... **85c**

Jacobs Chuck Keys

F 9 T 2051—Jacobs No. 1 key. Fits Jacobs following chucks: Nos. 1, 1A, 1B, 1BB, 1BS. Postpaid. (Shipping weight 4 ounces)..... **30c**
9 T 2054—Jacobs No. 32 key. Fits following Jacobs chucks: Nos. 32, 32B, 32BB, 33, 33B, 33BB, 9, 11, 381. Postpaid. (Shpg. wt. 7 oz.)..... **40c**
9 T 2052—Jacobs No. 3 key. Fits following Jacobs chucks: Nos. 3, 3A, 3B, 3AE, 6, 6A-2A, 6A-33, 6B, 6AE, 14, 34, 34B, 54B, 55B, 56B, 58B, 75A. Postpaid. (Shipping weight 8 ounces)..... **50c**
9 T 2053—Jacobs No. 4 key. Fits following Jacobs chucks: Nos. 4, 16, 18, 36, 36B, 59B. Postpaid. (Shipping weight 12 ounces)..... **75c**

Sears Easy Terms make it easy for you to have a completely equipped power tool shop... for complete information see inside back cover

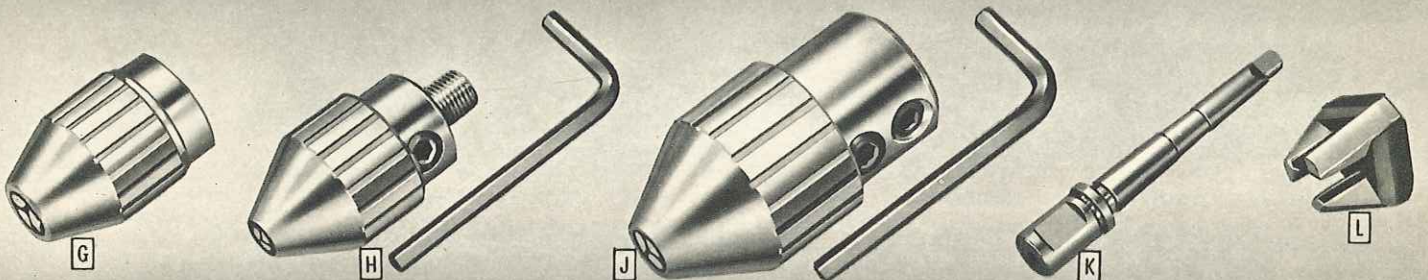

Jacobs Hand Tite Chucks

For use with many electric tools.
G 9 T 2175—Jacobs No. 4164. Capacity 0 to $\frac{1}{4}$ in. Tapped $\frac{1}{2}$ in. x 20-thread. Postpaid. (Shpg. wt. 8 oz.)..... **\$1.30**
9 T 2145—Jacobs No. 4165. Capacity 0 to $\frac{1}{4}$ inch. Tapped $\frac{1}{2}$ in. x 24-thread. Postpaid. (Shpg. wt. 8 oz.)..... **\$1.30**
9 T 2146—Jacobs No. 4191. Capacity 0 to $\frac{1}{4}$ inch. Tapped $\frac{3}{8}$ in. x 24-thread. Postpaid. (Shpg. wt. 8 oz.)..... **\$1.30**
9 T 2176—Jacobs No. 4364. Capacity 0 to $\frac{3}{8}$ inch. Tapped $\frac{1}{2}$ in. x 20-thread. Postpaid. (Shpg. wt. 1 lb. 2 oz.)..... **\$2.00**
9 T 2147—Jacobs No. 4365. Capacity 0 to $\frac{3}{8}$ inch. Tapped $\frac{1}{2}$ in. x 24-thread. Postpaid. (Shpg. wt. 1 lb. 2 oz.)..... **\$2.00**
9 T 2177—Jacobs No. 4464. Capacity $\frac{1}{8}$ to $\frac{1}{2}$ in. Tapped $\frac{1}{2}$ in. x 20-thread. Postpaid. (Shpg. wt. 1 lb. 2 oz.)..... **\$2.00**
9 T 2149—Jacobs No. 4465. Capacity $\frac{1}{8}$ to $\frac{1}{2}$ in. Tapped $\frac{1}{2}$ in. x 24-thread. Postpaid. (Shpg. wt. 1 lb. 2 oz.)..... **\$2.00**

Jacobs Hex Key Chucks

For use with many electric tools.
H 9 T 2992—Jacobs No. 6141. Capacity 0 to $\frac{1}{4}$ in. Spindle $\frac{1}{8}$ in. x 24-thread. Postpaid. (Shpg. wt. 12 oz.)..... **\$2.30**
9 T 2993—Jacobs No. 6344. Capacity 0 to $\frac{3}{8}$ inch. Spindle $\frac{1}{2}$ in. x 20-thread. Postpaid. (Shpg. wt. 1 lb. 8 oz.)..... **\$4.00**
9 T 2999—Jacobs No. 6444. Capacity $\frac{1}{8}$ to $\frac{1}{2}$ inch. Spindle $\frac{1}{2}$ in. x 20-thread. Postpaid. (Shpg. wt. 1 lb. 8 oz.)..... **\$4.00**
J 9 T 2936—Jacobs No. 6325. Capacity 0 to $\frac{3}{8}$ in. Bored $\frac{1}{2}$ -inch straight hole. Postpaid. (Shpg. wt. 1 lb. 8 oz.)..... **\$4.00**
9 T 2937—Jacobs No. 6326. Capacity 0 to $\frac{3}{8}$ inch. Bored $\frac{3}{8}$ -inch straight hole. Postpaid. (Shpg. wt. 1 lb. 6 oz.)..... **\$4.00**
9 T 2938—Jacobs No. 6425. Capacity $\frac{1}{8}$ to $\frac{1}{2}$ in. Bored $\frac{1}{2}$ -inch straight hole. Postpaid. (Shpg. wt. 1 lb. 8 oz.)..... **\$4.00**
9 T 2939—Jacobs No. 6426. Capacity $\frac{1}{8}$ to $\frac{1}{2}$ in. Bored $\frac{3}{8}$ -inch straight hole. Postpaid. (Shpg. wt. 1 lb. 6 oz.)..... **\$4.00**

Jacobs Arbors

K 9 T 2384—Jacobs No. A0025. Fits chuck 9T2936 (Jacobs 6325) and 9T2938 (Jacobs 6425) at left. No. 0 Morse taper on one end, $\frac{1}{2}$ -inch ground straight shank on other. Postpaid. (Shpg. wt. 8 oz.) 90c
9 T 2385—Jacobs No. A0026. Fits chucks 9T2937 (Jacobs 6326) and 9T2939 (Jacobs 6426) at left. No. 0 Morse taper on one end, $\frac{3}{8}$ -inch ground straight shank on other. Postpaid. (Shpg. wt. 8 oz.)..... 90c
9 T 2386—Jacobs No. A0125. Fits chucks 9T2936 (Jacobs 6325) and 9T2938 (Jacobs 6425) at left. No. 1 Morse taper on one end, $\frac{1}{2}$ -inch ground straight shank on other. Postpaid. (Shpg. wt. 12 oz.)..... 90c
9 T 2387—Jacobs No. A0126. Fits chucks 9T2937 (Jacobs 6326) and 9T2939 (Jacobs 6426) at left. No. 1 Morse taper on one end, $\frac{3}{8}$ -inch ground straight shank on other. Postpaid. (Shpg. wt. 12 oz.)..... 90c
9 T 2388—Jacobs No. A0225. Fits chucks 9T2936 (Jacobs 6325) and 9T2938 (Jacobs 6425) at left. No. 2 Morse taper on one end, $\frac{1}{2}$ -inch ground straight shank on other. Postpaid. (Shpg. wt. 14 oz.)..... 90c
9 T 2389—Jacobs No. A0226. Fits chucks 9T2937 (Jacobs 6326) and 9T2939 (Jacobs 6426) at left. No. 2 Morse taper on one end, $\frac{3}{8}$ -inch ground straight shank on the other end. Postpaid. (Shpg. wt. 14 oz.) 90c

Jacobs Collets

L Replacement collets that fit Jacobs chucks as listed.
9 T 2180—Jacobs No. J61. 0 to $\frac{1}{4}$ inch. Fits chucks 9T2175, 9T2145, 9T2146, 9T2992, left. Postpaid. (Shpg. wt. 4 oz.)..... **70c**
9 T 2181—Jacobs No. J63. Capacity 0 to $\frac{3}{8}$ inch. Fits chucks 9T2176, 9T2147, 9T2993, 9T2936, 9T2937, listed at left. Interchangeable in chucks using 9T2182 below. Postpaid. (Shpg. wt. 8 oz.)..... **\$1.40**
9 T 2182—Jacobs No. J64. Capacity $\frac{1}{8}$ to $\frac{1}{2}$ inch. Fits chucks 9T2177, 9T2149, 9T2938, 9T2939, 9T2999 listed at left. Interchangeable in chucks using 9T2181 above. Postpaid. (Shpg. wt. 8 oz.)..... **\$1.40**

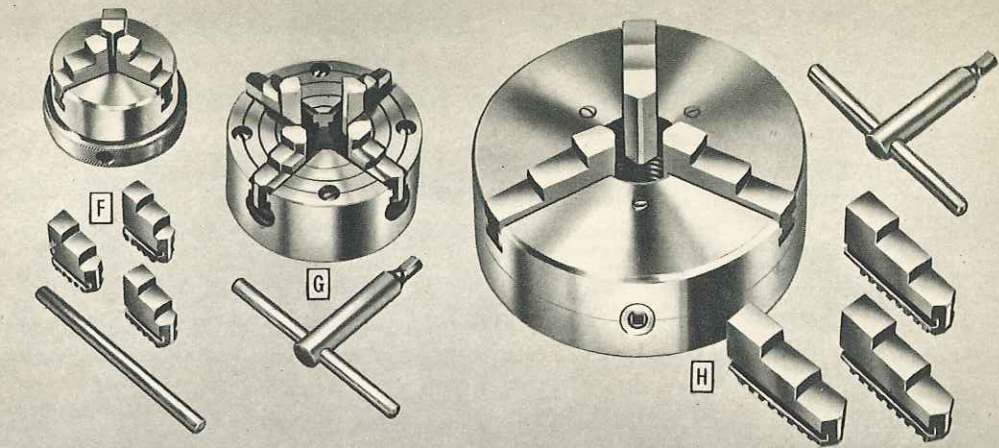
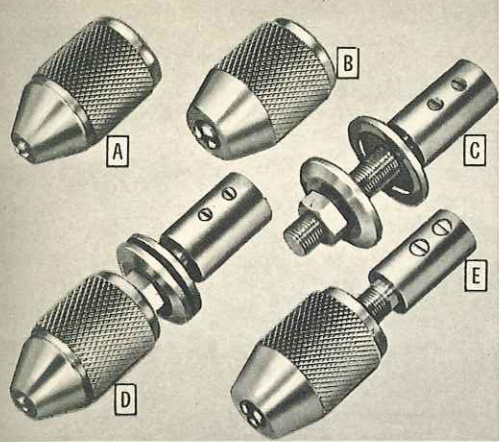

Drill Chucks, Arbors

3-jaw Chucks . . screw-on type

CRAFTSMAN quality. Hardened steel jaws center accurately. Knurled for firm grip. *Check spindle size.*

- A Tapped to fit 1/2-inch x20 thread spindles.
9 T 2248—1/4-inch capacity. Shpg. wt. 5 oz. 77c
9 T 2243—3/8-inch capacity. Shpg. wt. 12 oz. 85c
9 T 2256—1/2-inch capacity. Shpg. wt. 12 oz. 92c

- Tapped to fit 1/2-inch x24 thread spindles.
9 T 2130—1/4-inch capacity. Shpg. wt. 5 oz. 77c
9 T 2244—3/8-inch capacity. Shpg. wt. 8 oz. 85c
9 T 2132—1/2-inch capacity. Shpg. wt. 12 oz. 92c

- B 9 T 2264—CRAFTSMAN deluxe chuck, 1/2-inch capacity. Tapped 1/2-inch x 20 thread. With chuck spanner wrench. Shipping wt. 1 lb. \$1.19

- C 9 T 2164—CRAFTSMAN general purpose Work Arbor. Converts your motor into a grinder, polisher, buffer, etc. Of carbon steel, 4 in. long, 2 3/8 in. spindle has 1/2-in. x 20 thread. Steel collars for clamping, grinding or buffing wheels. Fits 1/2 or 3/8 in. unthreaded shaft. Fastens with 2 set screws. State whether for 1/2 or 3/8-in. spindle. Shpg. wt. 12 oz. 65c

Arbors with 3-jaw, 1/2-inch Drill Chucks

- D 9 T 2151—Chuck and 1/2-in. x 20 thread arbor with steel collars. Fits 1/2 or 3/8-in. unthreaded straight spindle. Fastens with 2 set screws. State whether for 1/2 or 3/8-in. spindle. Shpg. wt. 1 lb. 10 oz. \$1.39
- E 9 T 2270—CRAFTSMAN deluxe chuck, 3/8-in. capacity; with 1/2-in. x 20 thread arbor. Fits 1/2 or 3/8-in. unthreaded straight spindle. Fastens with 2 set screws. Has chuck spanner wrench. State whether for 1/2 or 3/8-in. spindle. Shpg. wt. 1 lb. 6 oz. \$1.39

3-jaw Universal

F CRAFTSMAN. Finest quality in design, materials and construction. Self-centering, lever-operated type . . . has only two main parts, body and scroll. Ideal for production work because of speedy gripping. Centers accurately . . . tolerances held to within .003 inch.

Case-hardened, cold rolled steel jaws; polished steel body and scroll. Knurled rim permits easy hand operation. Body casting is precision threaded to fit directly on spindle. Has two sets of jaws; one for outside and one for inside gripping. Chuck wrench included. In five sizes. Fit lathes with spindle diameters and threadings listed below.

- 9 T 2295—CRAFTSMAN. Fits 1/2-in. by 20-thread spindle. Diameter 2 in. Shpg. wt. 1 lb. 12 oz. \$16.95
- 9 T 2296—CRAFTSMAN. Fits 1/2-in. by 20-thread spindle. Diameter 3 in. Shpg. wt. 3 lbs. 5 oz. \$17.95
- 9 T 2297—CRAFTSMAN. Fits 1-in. by 8-thread spindle. Diameter 4 in. Shpg. wt. 6 lbs. 5 oz. \$22.25
- 9 T 2298—CRAFTSMAN. Fits 1 1/2-in. by 8-thread spindle. Diameter 5 in. Shpg. wt. 10 pounds. \$26.25
- 9 T 02299—CRAFTSMAN. Fits 1 1/2-in. by 8-thread spindle. Diam. 6 inches. Shpg. wt. 15 lbs. \$33.95

4-jaw Independent

G CRAFTSMAN. Precision made of finest materials. Body of special alloy steel has deep, wide jaw slots for added strength and greater bearing surface. For average shop needs.

Four reversible jaws, drop forged from a solid bar of special steel, work independently; especially useful for holding irregular shaped pieces. Large diameter jaw screw for extra strength; Acme threaded. T-handle chuck wrench included. Fit any lathe with spindle diameters and threads per inch listed below. In six sizes:

- 9 T 2137—CRAFTSMAN. Fits 1/2-inch by 24 thread spindle. Diameter 3 in. Shpg. wt. 2 lbs. 8 oz. \$7.25
- 9 T 2157—CRAFTSMAN. Fits 3/8-inch by 20 thread spindle. Diameter 3 in. Shpg. wt. 2 lbs. 8 oz. \$7.25
- 9 T 2156—CRAFTSMAN. Fits 3/4-inch by 16 thread spindle. Diameter 4 in. Shpg. wt. 3 lbs. 10 oz. \$8.50
- 9 T 2138—CRAFTSMAN. Fits 1-inch by 8 thread spindle. Diameter 4 in. Shpg. wt. 3 lbs. 12 oz. \$8.50
- 9 T 2139—CRAFTSMAN. Fits 1 1/4-inch by 8 thread spindle. Diameter 6 in. Shpg. wt. 9 lbs. 10 oz. \$15.95
- 9 T 02141—CRAFTSMAN. Fits 1 1/2-inch by 8 thread spindle. Diameter 8 in. Shpg. wt. 25 lbs. \$28.50

3-jaw Universal

H CRAFTSMAN fine quality in precision construction, materials and craftsmanship. 3-jaw, self-centering type. Jaws are controlled by single screw and pinion gear . . . ideal for production work because of their speedy gripping and accurate centering.

Chuck body casting of high strength semi-steel construction. Special alloy metal scroll and alloy steel pinion. Alloy steel jaws are heat treated and hardened; have raised, precision ground steps . . . accurate within standard chuck tolerances. Complete with two sets of jaws (outside and inside). T-handle chuck wrench included.

- 9 T 2148—Fits 1-inch by 8 thread spindle. Diameter 4 inches. Shipping wt. 4 lbs. 8 oz. \$34.00
- 9 T 2150—Fits 1 1/2-inch by 8 thread spindle. Diameter 5 inches. Shipping wt. 6 lbs. 11 oz. \$35.50

Buy it NOW on Sears Easy Terms. See inside back cover.

CRAFTSMAN quality Lathe Chucks

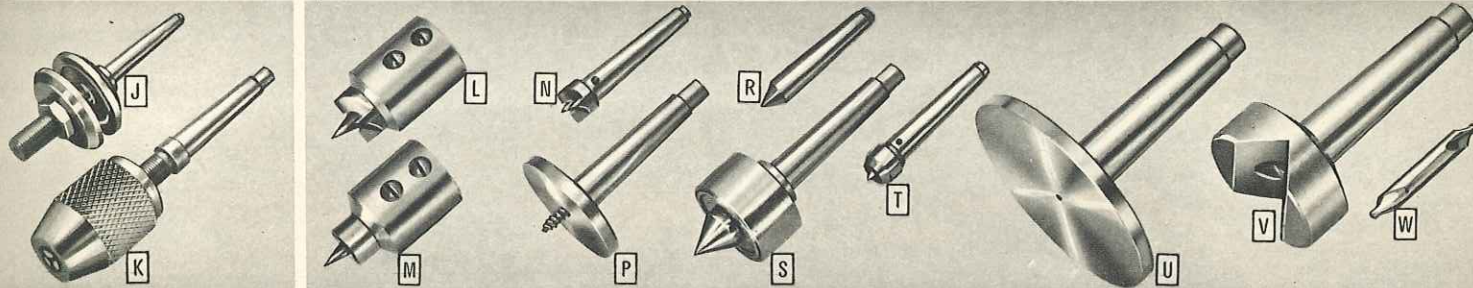

Arbors and Chucks

- J Work Arbors. For mounting drill chucks and holding grinding, buffing and wire scratch wheels, etc. 1/2-in. x 20 thread. Morse taper shank. 2 steel collars with nut on head end for clamping wheels. Shpg. wt. 8 oz. 98c
- K 9 T 2153—No. 1 Morse taper. Shpg. wt. 9 oz. 93c
- 9 T 2152—No. 2 Morse taper. Shpg. wt. 13 oz. \$1.05
- K Work Arbors with Chucks. 3-jaw, screw-on type chucks, tapped 1/2-inch x 20 thread; 1/2-in. capacity. Have Morse taper, shank end. 9 T 2234—Chuck and Arbor with No. 1 Morse taper. Shpg. wt. 1 lb. 8 oz. . . . \$1.95
- 9 T 2247—Chuck and Arbor with No. 2 Morse taper. Shpg. wt. 1 lb. 8 oz. . . \$1.95

CRAFTSMAN fine quality Lathe Centers and Accessories

- Lathe Centers. Ideal for use on any lathe with 3/8-inch straight spindle. Fasten with 2 set screws. Precision made of ground and hardened steel. Especially designed for maximum strength and rigidity. Has replaceable center point.
- L 9 T 2105—Headstock Spur Center. For driving work mounted between centers. Shipping weight 6 ounces. 93c
- M 9 T 2102—Tailstock Cup Center. Supports work in tailstock. Shipping weight 6 ounces. 93c
- N Spur Centers. Use for wood turning. Accurately ground for perfect fit. Morse taper shank as listed below. 9 T 2108—No. 0 Morse taper. Shipping weight 3 ounces. 67c
- 9 T 2106—No. 1 Morse taper. Shipping weight 4 ounces. 85c
- 9 T 2107—No. 2 Morse taper. Shipping weight 7 ounces. 87c
- P Screw Centers. For facing and hollowing operations. Replaceable center. Morse taper shank as listed below. 9 T 2116—No. 1 Morse taper. Shipping weight 12 ounces. . . \$1.45
- 9 T 2115—No. 2 Morse taper. Shipping weight 14 ounces. . . 1.45
- R 60-degree Centers. Morse taper shank as listed below. 9 T 2103—No. 0 Morse taper. Shipping weight 3 ounces. . . 57c
- 9 T 2110—No. 1 Morse taper. Shipping weight 8 ounces. . . . 65c
- 9 T 2111—No. 2 Morse taper. Shipping weight 10 ounces. . . . 67c

- S Precision ball bearing 60-degree center. (Center point rotates on ball bearing.) Recommended for high speed operations. Morse taper shank as listed below. 9 T 2112—No. 1 Morse taper. Shipping weight 8 ounces. . . \$2.85
- 9 T 2113—No. 2 Morse taper. Shipping weight 8 ounces. . . . 2.85
- T Tailstock Cup Centers. Supports work in tailstock. Ground and hardened steel with replaceable center point. Morse taper shank as listed below. 9 T 2109—No. 0 Morse taper. Shipping weight 3 ounces. . . . 65c
- 9 T 2100—No. 1 Morse taper. Shipping weight 5 ounces. . . . 67c
- 9 T 2101—No. 2 Morse taper. Shipping weight 7 ounces. . . . 87c
- U 9 T 2187—Drill Pad. Used in tailstock as rigid support for drilling flat or square work with drill in headstock. Ground steel shank has No. 2 Morse taper. Diameter of face is 3 1/4 inches. Shipping weight 1 pound 2 ounces. \$1.45
- V 9 T 2114—Crotch Center. Automatically centers round work in tailstock for accurate cross-drilling. V-slot is precision machined. Ground steel shank has No. 2 Morse taper. Shipping weight 1 pound. \$1.45
- W 9 T 2061—Center Drill. Combination drill and countersink. In 1/2 or 3/8-in. size. State size wanted. Shpg. wt. 1 oz. 45c

CRAFTSMAN "80" Metal Turning Lathe

Designed and priced for use in home and other small workshops

- Back gears produce power necessary for machining different metals
- Offset center construction gives smoother, more accurate performance
- Wide speed range permits wood and plastic turning; taper turning easily and quickly accomplished by setting-over tailstock

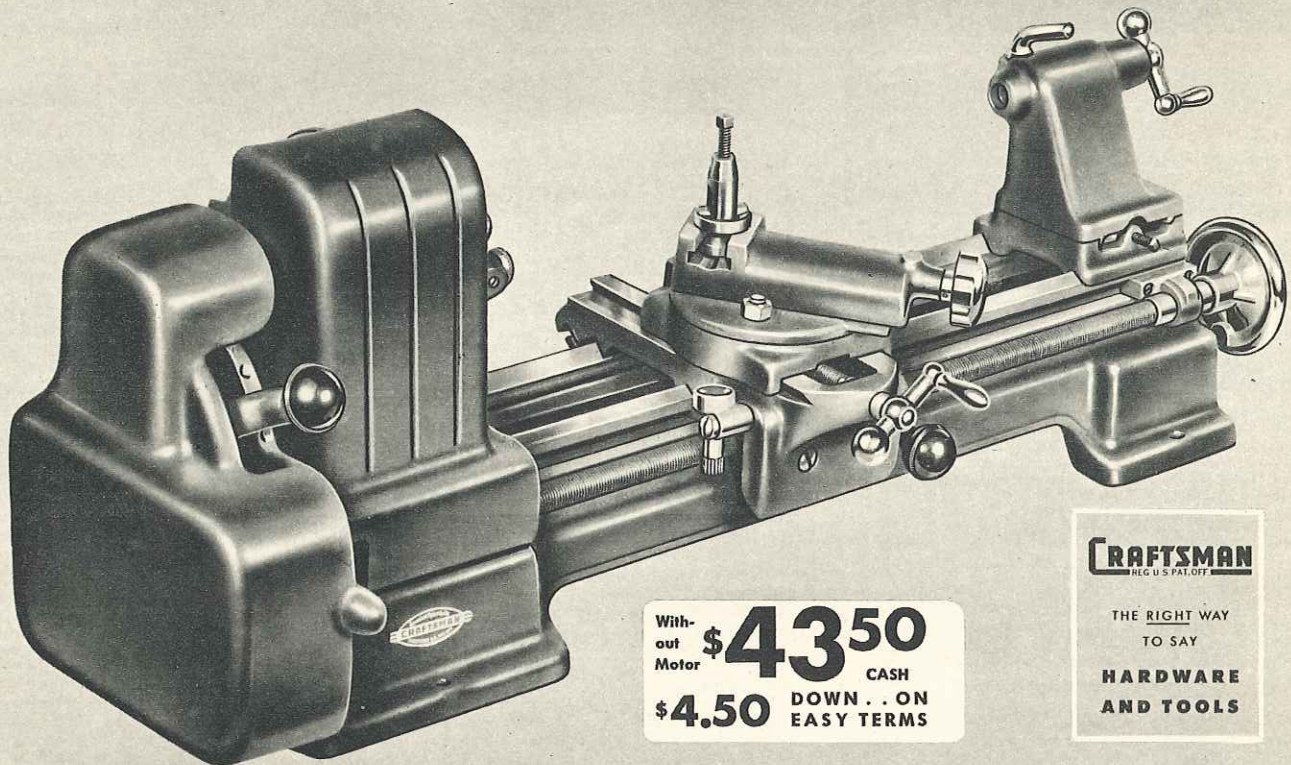

Without Motor **\$43.50** CASH
 \$4.50 DOWN . . . ON EASY TERMS

CRAFTSMAN
 REG. U. S. PAT. OFF.
 THE RIGHT WAY
 TO SAY
**HARDWARE
 AND TOOLS**

6-inch swing . . . 12 inches between centers . . . 22 1/4-in. bed

Here is a complete back-gear screw cutting lathe that will increase tremendously the work you can do in your shop. It is specially designed for precise work such as turning armatures, model making, repair, experimental and tool room work. The speed range . . . 120 to 1325 R.P.M. . . . permits wood and plastic turning. The precision construction in every detail plus the CRAFTSMAN quality features make this lathe a sensational buy!

Offset center construction. Centers offset 1/4 inch back of bed center line increase the lathe capacity; give greater support to compound and keeps pressure of work on tool bit between the ways, even when handling larger work.

Sturdy cast iron bed has heavy cast inverted U type ribbing. V-way bed and undercuts machined at same time for better alignment. Removable No. 0 Morse taper centers in headstock and tailstock. Tailstock may be set over 1/4-inch for turning tapers.

Double bearing headstock. Oilite bronze front bearing adjustable. Taper take-up in front spindle bearing adjusts for longer wear, smoother, more accurate operation.

Compound rest and cross feed. Accurately gibbed for wear-take-up. Complete with accessories shown at left. For arbors and chucks to fit above lathe, see pages 32 and 33.

SPECIFICATIONS:

- Swing over bed 6 inches
- Distance between centers 12 inches
- Spindle: Nose size 1/2 inch—20 thread
Taper No. 0 Morse
Bore 1/4 inch
- Bearings 2 oilite bronze
- Thread range 8 to 96—right or left hand
- Feeds0024, .0039, .0048, .0078
- Back gear ratio5 to 1
- Compound rest travel 1 3/4 inches
- Cross slide travel 2 3/4 inches
- Tailstock ram travel 1 1/4 inches
- Tailstock set over 1/4 inch
- Motor recommended minimum 1/4 H.P. 1750 R.P.M.
- Machine pulley (included) 3 step "V" type
- Motor pulley (included) 4 step "V" type
- Speeds Six: 120 to 1325 R.P.M.
- Mounting dimensions 18 3/8 x 5 inches
- Over-all dimensions: Height, 9 1/2 inches; width, 8 3/4 inches; length, 26 inches.

99 TM 2063—Without motor. Shpg. wt. 55 lbs. \$43.50
 99 TM 2064—With 1/4 H.P. 1750 R.P.M. 110-120 volt 60 cycle A.C. split phase sleeve bearing motor. Shpg. wt. 79 lbs. \$57.00

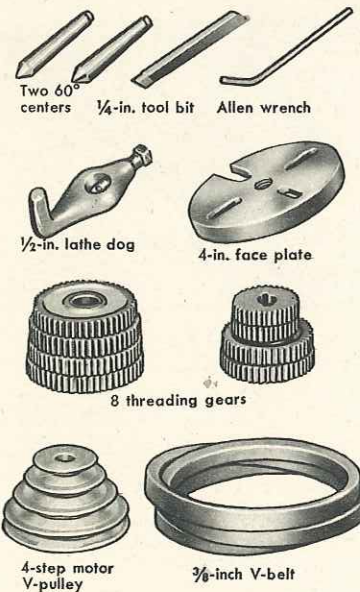

Two 60° centers 1/4-in. tool bit Allen wrench

1/2-in. lathe dog 4-in. face plate

8 threading gears

4-step motor V-pulley 3/8-inch V-belt

6-piece Tool Bit Set . . ground and shaped

\$2.35
 Set

Six-piece set of 1/4-inch bits of high speed tool steel. Accurately ground to shape and ready for immediate use. Finest materials and workmanship. Good bits for steady production work. Set includes one each of the following: threading bit, left hand facing bit, right hand turning bit, round nose turning bit, right hand facing bit and left hand turning bit.

9 TM 2205—Shipping weight 8 ounces. Set of six **\$2.35**

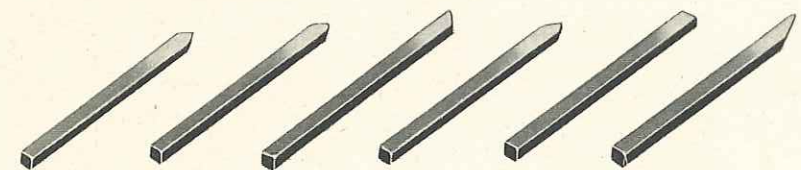

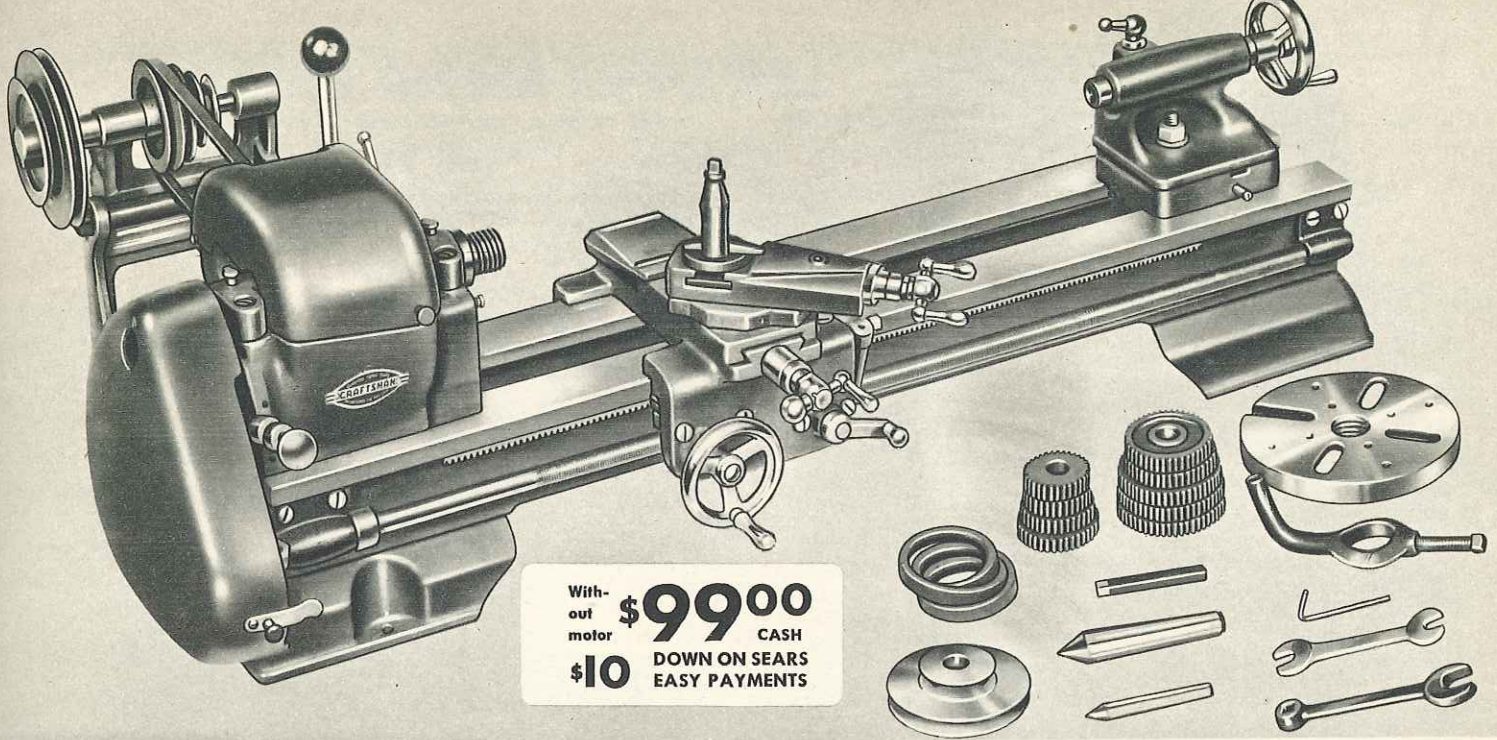

With-
out
motor **\$99.00** CASH
\$10 DOWN ON SEARS
EASY PAYMENTS

CRAFTSMAN Model Makers' Lathe

REG. U.S. PAT. OFF.

The lathe designed, built and priced just for you; model makers, hobbyists, tool makers, etc. Guaranteed accurate within 1/1000th of an inch at spindle.

Full 6-inch swing . . . 18 inches between centers . . . 30 inch bed. Allows you to do wide variety of jobs. Has massive, one-piece, cast semi-steel, precision ground bed. Carriage has hand wheel for manual operation and feed lever for reversible automatic power feed. Tailstock has set-over for taper turning.

Cuts 8 to 96 threads per inch, right or left hand. Back gears give 16 speeds from 54 to 3225 R.P.M. A correct speed for all turning, finishing or polishing. Graduated compound rest swivels 360 degrees.

- SPECIFICATIONS:**
- Swing over bed 6 inches
 - Distance between centers 18 inches
 - Spindle: Nose 1 inch-8 thread
Taper No. 2 Morse
Bore 1 1/2 inch
 - Spindle bearing 2 oilite bronze; 1 ball thrust
 - Thread range 8 to 96, right or left hand
 - Feeds Four: .0024, .0039, .0048 and .0078
 - Back gear ratio approximately 6 1/2 to 1
 - Countershaft and back gear bearings 4 oilite bronze
 - Swing over carriage 4 1/2 inches
 - Compound rest travel 1 1/4 inches

- Cross slide travel 4 1/4 inches
 - Tailstock taper No. 1 Morse
 - Tailstock ram travel 1 1/4 inches
 - Tailstock set-over 9/16 inch
 - Motor recommended, minimum 1/4 H.P. 1750 R.P.M.
 - Machine pulley (included) 4 step
 - Motor pulley (included) 2 step
 - Mounting dimensions 4 3/4 x 27 1/2 x 1 1/2 inches
 - Over-all dimensions: Height 10 1/4 inches; width 21 1/2 inches; length 33 1/2 inches
- Comes with instructions and accessories shown above
99TM2048—Without motor. Shipping weight 110 lbs. \$99.00

Accessories for above lathe to make it more useful

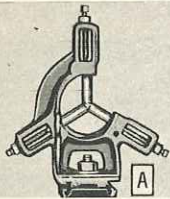

Steady Rest

A Base clamps securely to bed ways. Gives added support needed when turning long pieces. Handles diameters up to 2 1/2 inches. Shipping weight 5 lbs. 8 oz.

9 T 2041 \$6.50



Follower Rest

B Mounts on back of carriage dovetail slide . . . moves with cutting tool to provide support needed to prevent deflection when turning long, slender work. Shpg. wt. 3 lbs. 8 oz.

9 T 2042 \$4.10

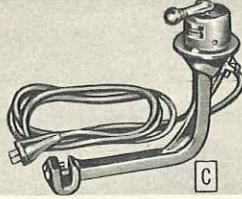

Reversing Switch

C Reverses motor and spindle direction when grinding, polishing, tapping and wood and metal finishing. Not suitable for repulsion-induction motors. Shpg. wt. 5 lbs.

9 T 2039 \$7.60

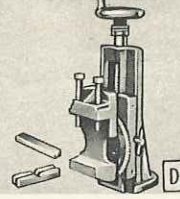

Milling Attachment

D Has graduated swivel vise, flat block and V-block for holding cylindrical objects. Vise capacity 2 inches; vertical feed 1 1/4 inches. Graduated swivel. Shipping weight 8 pounds 8 ounces.

9 T 2057 \$21.50

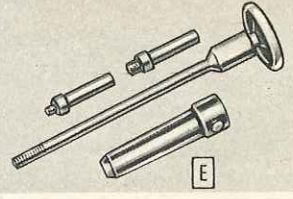

Holding Collet

E This attachment will hold threaded-hole angular milling and keyway cutters and 1/2-inch end mills. Shipping wt. 2 lbs.

9 T 2059 \$9.25

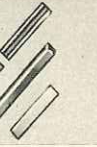

Tool Holders

Designed to fit 99 TM 2048 Lathe above. Made of special drop forged steel, expertly heat treated and hardened. Accurately machined. Set screws of finest alloy steel. Holders use 3/16-inch tool bits listed at right.

- F** 9 T 2031—Threading Tool. With wrench. Shpg. wt. 14 oz. . . . \$4.45
- G** 9 T 2033—Straight Tool Holder. No bit. Shpg. wt. 12 oz. . . . \$1.85
- H** 9 T 2034—Right Hand Tool Holder. No bit. Shpg. wt. 12 oz. . . . \$1.85

- J** 9 T 2035—Left Hand Tool Holder. No bit. Shpg. wt. 12 oz. . . . \$1.85
- K** 9 T 2037—Cut-Off Tool. Wrench included. Shpg. wt. 14 oz. . . \$2.65
- L** 9 T 2036—Knurling Tool. Has medium knurls. Shpg. wt. 14 oz. \$5.15

Formed Tool Bit Set

M Six-piece set of 3/16 inch tool bits. Made of high speed tool steel. Accurately ground to shape, ready for use. Good for production work. Set includes one each of the following: threading bit, left hand facing bit, left hand turning bit, right hand turning bit, right hand facing bit and round nose turning bit.

9 T 2043—Shpg. wt. 5 oz. \$2.29

Tool Post Set

N Ideal for precision boring jobs requiring rigid tool mounting. Tools mount directly in tool post. Made of high speed tool steel. Set includes the following: four boring bars, internal threading tool, external threading tool, external turning tool and set of tool post spacers for height spacing.

9 T 2038—Shpg. wt. 14 oz. . . . \$6.85

Buy your Power Tools on Sears Easy Terms . . . only 10% down . . . balance monthly. See inside back cover for details

CRAFTSMAN Metal Lathe . . .

REG. U.S. PAT. OFF.

Lathe Manual, containing 234 pages of sound and practical explanations of metal lathe operations and construction, is included with these CRAFTSMAN metal turning lathes.



Accessories for metal lathe shown above

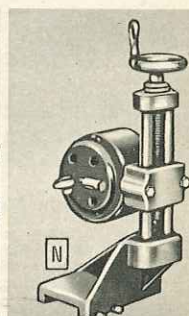
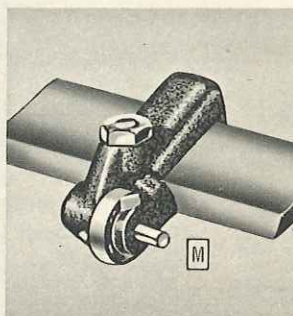
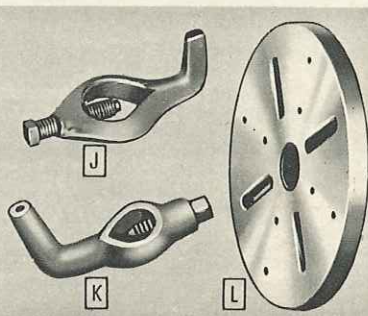
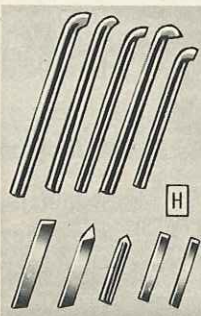
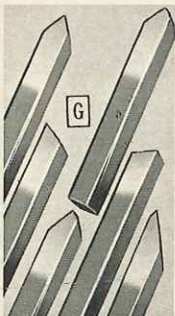
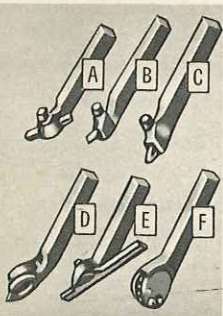

Tool Holders

Steel forgings; expertly made and carefully finished. For use with $\frac{1}{4}$ -inch tool bits shown below. Shanks are $\frac{3}{8}$ -inch high; $\frac{3}{8}$ -inch wide. Shipping weight each 2 pounds.

- A 9 T 2194—Offset, left. \$1.98
- B 9 T 2192—Offset, right. 1.98
- C 9 T 2196—Straight. . . . 1.98
- D 9 T 2198—Threading. . . . \$4.50
- E 9 T 2200—Cut-off. 2.85
- F 9 T 2202—Knurling tool. . . 5.60

6 Formed Tool Bits

Handy bits that are ground ready to use. $\frac{1}{4}$ -inch size. Fit the tool holders listed above. Shipping weight 8 ounces. Set includes:

- Threading bit
- Left hand facing bit
- Right hand facing bit
- Right hand turning bit
- Round nose turning bit
- Right hand facing bit
- Left hand turning bit

9 T 2205—Set of 6 tool bits. \$2.35

Tool Post Tool Set

Set includes 4 boring tools ($\frac{3}{16}$, $\frac{1}{4}$, $\frac{5}{16}$ and $\frac{3}{8}$ inch); $\frac{1}{4}$ -inch inside threading tool; $\frac{3}{8}$ -inch turning tool; $\frac{3}{8}$ inch threading tool and set of tool post spacers.

9 T 2189—Shipping weight 2 pounds. \$7.40

Lathe Dogs

Made of malleable iron. Holds work firmly. Choice of four sizes: $\frac{1}{2}$, $\frac{3}{4}$, 1 or $1\frac{1}{2}$ -inch size. State size wanted.

9 T 2078—Shipping wt. 8 oz. 55c

Made of forged steel. Heat treated and hardened. Set screw. Holds work firmly in position. Choice of four sizes. State size.

9 T 2183—Shipping weight each, 1 pound.

$\frac{1}{2}$ inch. 98c 1 inch. \$1.09

$\frac{3}{4}$ inch. \$1.05 $1\frac{1}{2}$ inch. 1.22

Face Plates

For use on lathes on this page or any lathe with $1\frac{1}{2}$ -in., 8-thread spindle.

- 9 T 2471—4-inch. Shpg. wt. 3 lbs. . . . \$3.70
- 9 T 2098—6-inch. Shpg. wt. 3 lbs. . . . 3.00
- 9 T 2475—8-inch. Shpg. wt. 6 lbs. . . . 5.45

Micrometer Carriage Stop

Has adjustable micrometer stop to indicate stopping place for carriage in boring or facing to a given depth; cutting off at a given point; duplicating longitudinal cuts; and laying out work on a cylindrical surface. Clamps on front of bed way. Fits all the CRAFTSMAN lathes listed on the bottom of the opposite page.

9 T 2185—Shipping weight 1 lb. \$5.50

Mica Undercutter

Easily and quickly fastens to the back of carriage. Screw feed regulates height of cutter and carriage feed moves cutter into commutator slot. For use on 110-120 volt 25-60 cycle A.C. D.C. Comes complete with motor, switch, cord, set of 5 undercutting saws. Fits all the CRAFTSMAN lathes listed on the bottom of the opposite page.

9 T 2989—Shipping weight 10 lbs. \$32.25

For complete information about Easy Terms, see inside back cover

Guaranteed accurate to one-thousandth inch

- Famous Timken tapered roller bearings maintain spindle alignment and absorb radial and thrust loads
- Guards completely cover headstock and motor pulley

- Thread range from 4 to 96 threads per inch, either right or left hand (standard) Metric .5 to 7.0 m.m.
- Reversible power cross feed makes facing work easier

99 TM 2075 **\$199.00**
CASH

\$20 DOWN . . ON
SEARS EASY PAYMENTS

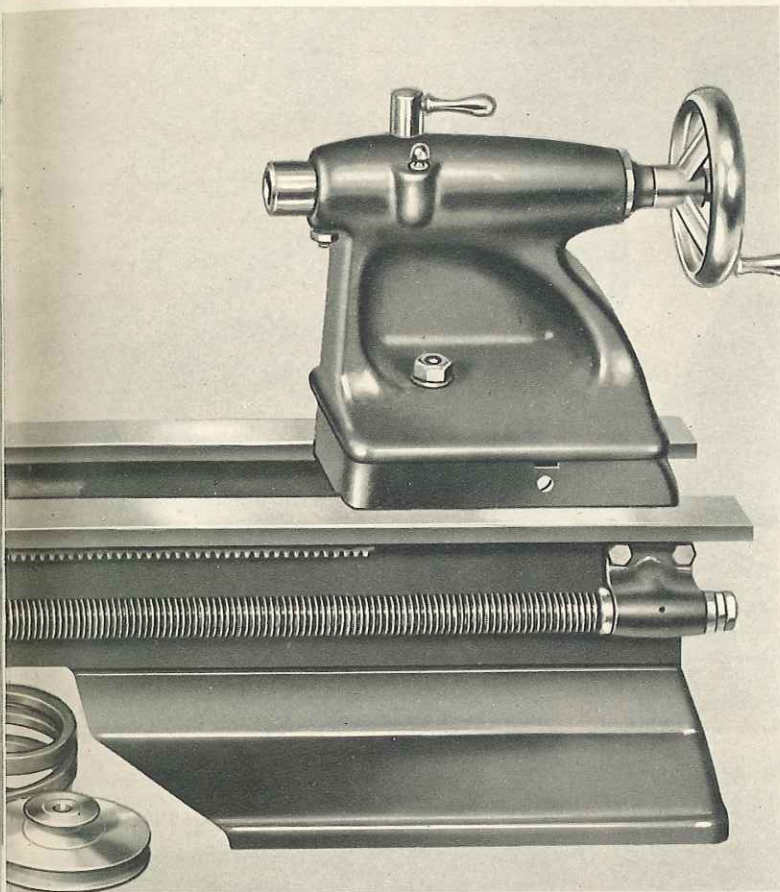

The ability of this CRAFTSMAN metal turning lathe to cut accurately to 1/1000th inch even after years of usage is the result of precision construction and expert design. It's outstanding in workmanship, materials, versatility and price.

Famous Timken tapered roller bearings in headstock assure smooth, fast cutting even at high spindle speeds. Maintain spindle alignment and absorb the radial and thrust loads. Rugged massive construction.

Reversible power cross feed and longitudinal feed permits you to do your facing work accurately and automatically. Simple and easy to operate. Tailstock has set over for taper turning.

Quick-change countershaft. Guards completely cover headstock and motor driven pulleys. Hinged for quick speed changes. Powered with V-belt drive. Keeps lathe clean; helps prevent accidents. Check the following specifications.

SPECIFICATIONS:	99 TM 2075	99 TM 2079
• Swing over bed	12 1/4 inches	12 1/4 inches
• Distance between centers	24 inches	36 inches
• Spindle, Nose size	1 1/2 in.—8 thread	1 1/2 in.—8 thread
Taper	No. 2 Morse	No. 2 Morse
Bore	2 1/2 inch	2 1/2 inch
• Spindle bearings	2 Timken roller	2 Timken roller
• Thread range	4 to 96 R.H. or L.H.	4 to 96 R.H. or L.H.
• Feeds	.0024; .0035; .005; .0071; .0087	
• Back gear ratio	Approx. 6 to 1	Approx. 6 to 1
• Countershaft and back gear bearings	4 oilite bronze	4 oilite bronze
• Swing over carriage	8 5/8 inches	8 5/8 inches
• Compound rest travel	2 3/8 inches	2 3/8 inches
• Cross feed	Reversible; power feed	Reversible; power feed
• Cross slide travel	6 1/2 inches	6 1/2 inches
• Tailstock taper	No. 2 Morse taper	No. 2 Morse taper
• Tailstock ram travel	2 3/4 inches	2 3/4 inches
• Tailstock set over	3/4 inch	3/4 inch
• Machine pulley (included)	6 inch 4 step	6 inch 4 step
• Motor pulley (included)	4 1/2 inch 2 step	4 1/2 inch 2 step
• Speeds	Sixteen 28 to 2072 R.P.M.	28 to 2072 R.P.M.
• Mounting dimensions	6 1/8 x 35 1/8 in.	6 1/8 x 47 1/8 in.
• Over-all dimensions, Height	20 inches	20 inches
Width	25 1/2 inches	25 1/2 inches
Length	45 inches	57 inches

Comes with tool post wrench, threading gears and 234-page lathe manual.
99 TM 2075—Shipping weight 275 pounds. **\$199.00**
99 TM 2079—Shipping weight 295 pounds. 214.00

For arbor see page 32 . . . For chucks see page 33

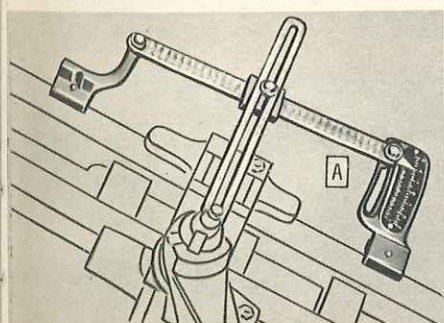

Taper Attachment

A An accurate taper attachment that's easily and quickly installed . . . simple to operate. You don't have to move the tailstock out of alignment when you use this attachment. Duplicate tapers can be cut accurately on pieces of different lengths. Internal boring work can be done as easily as external work. The index plate is graduated 7° and 3 in. both sides of the center line. Equivalent to taper of 2 1/8 in. per foot. Designed to fit lathes listed at the bottom of this page.
9 T 2984—Shipping weight 10 pounds. **\$23.50**

Reversing Switch

B Drum type reversing switch that is essential for grinding, tapping and all types of fine metal and wood finishing. The reversing motor reverses direction of lathe spindle. (Note: Do not use with repulsion—induction motors.) Comes with cord and plug.
9 T 2983—Shipping weight 5 pounds. **\$9.50**

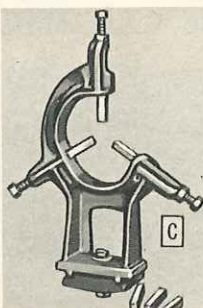
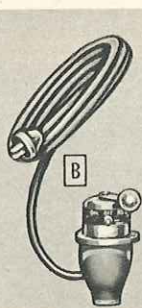

Steady Rest

C The sturdy solid brass jaws give rigid support to insure accuracy in turning, boring, and threading on your lathe. Especially useful for accuracy when turning, boring or threading long slender pieces. Clamps securely and rigidly to the bed ways. Has a capacity up to 2 1/2 inches. Comes complete with extra jaws. Ready for use.
9 T 2050—Shipping weight 7 pounds. **\$8.00**

Follower Rest

D Here's the accessory that will give you the necessary support for jobs that require a long cut on a small diameter. Enables you to do much more accurate and precise work. It fastens securely to the back of the carriage dovetail slide . . . follows the cutting tool. Essential for long slender pieces. Very convenient and easy to use.
9 T 2988—Shipping weight 4 pounds. **\$4.75**

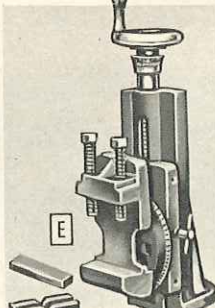

Milling Attachment

E Complete as shown, with graduated swivel vise, V-block for holding cylindrical objects. Vise capacity 2 3/4 inches. Vertical feed 2 3/4 inches. Cross feed 5 inches. Has graduated micrometer feed screw. Angular swivel accurately graduated in degrees. Easily and quickly mounted in place of compound rest.
9 T 2987—Shipping weight 16 pounds. **\$23.50**

Holding Collet

F Ideal for use on straight shank milling cutters. Furnished with two arbors, one to take threaded hole angular cutters, etc. Hand wheel type. Provides excellent means of holding milling cutters firmly and rigidly. Particularly valuable to those who are required to use many types of cutters frequently.
9 T 2994—Shipping weight 3 pounds. **\$9.50**
9 T 2985—Four bushings for use with 1/4, 3/16, 1/8 and 3/16 inch end mills. Shipping weight 4 oz. **2.30**

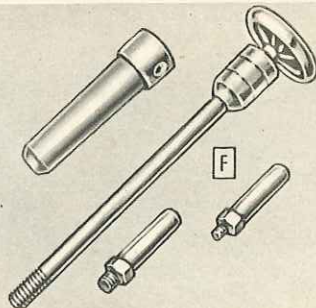

All the accessories shown above fit CRAFTSMAN lathes numbers 2065, 2067, 2069, 2071, 2073, 99TM2075, 2077, and 99TM2079

Only \$6.50 down on Easy Terms . . . Welders' Handbook included

Farmers! Factories and industrial shops! Garages, repair and welding shops! Scrap yard operators! Maintenance men! Just what you've been looking for . . . a quality-built oxy-acetylene welding outfit at a price you can afford. Soon pays for itself! Farmers, you can save money, make real profits, doing professional type welding for yourself and your neighbors.

It's easy to learn how to do welding, cutting, brazing and soldering. Informative Welders' Handbook, included with outfit, tells you what to do and shows you how to do it. A little practice gives you the skill needed to do a real job.

Oxy-acetylene welding outfit is readily portable. You can use it anywhere, even in areas where electrical power is not available or accessible. Make farm repairs in the field . . . no need to bring work into shop. Consult your classified telephone directory for nearest supplier of oxygen and acetylene.

Guaranteed quality! Actually triple tested to highest standards! (1) Every part individually factory tested many times during construction . . . and factory approved before shipment. (2) Tested and approved by Underwriters' Laboratories, Inc. (3) Tested and approved by Sears own Merchandise Testing Laboratory. In addition, these outfits are approved by Associated Factory Mutual Insurance Company.

You know CRAFTSMAN oxy-acetylene welding outfits are safe. All parts coming into contact with gas are made of SOLID brass or bronze. All joints are ground and hand fitted to eliminate danger of leaks. Regulators are equipped with patented safety pressure-relief devices. *Exclusive balanced-pressure non-flash mixer is located beyond the head of the torch and outside of the torch handle for safety.* Possibility of "flash-back" and burning on interior of torch has been minimized. No doubt about it, there's real super-quality built into every part of this outfit!

Heavy duty construction throughout! Made to handle toughest jobs! 17 1/4-inch bronze non-flash torch with mixer and 6-inch gooseneck. Gooseneck is bronze drop forging . . . will not bend. Forged solid-bronze-bodied regulators have two pressure gauges with steel cases: 0 to 80 and 0 to 3000-pound oxygen regulator, and 0 to 80 and 0 to 500-pound acetylene regulator.

Also included in this outfit! Five wide-range tips of one-piece solid drawn copper, highly polished (AA-1, AA-2, AA-3, AA-4, and AA-5); two 12 1/2-foot lengths of 1/4-inch high-pressure hose, tested to 800 lbs. per square inch; assorted welding rods; flux; lighter; two wrenches; 50-mm. welders' goggles and 224-page Welders' Handbook. Welder may be used as cutting torch, using 9 T 5444 attachment. See opposite page.

99 T 05442—As described above. Shpg. wt. 28 lbs. . . . \$65.00
9 T 5410—Flux only. Can be used for all types of acetylene welding. Shipping weight 1 pound 3 ounces. 1-lb. can. . . . \$6c
9 T 5411—224-page Welders' Handbook. Helpful; easy to understand. *Postpaid.* (Shipping weight 1 lb.) . . . \$2.85

\$65.00
CASH
\$6.50 DOWN . . .
ON TERMS

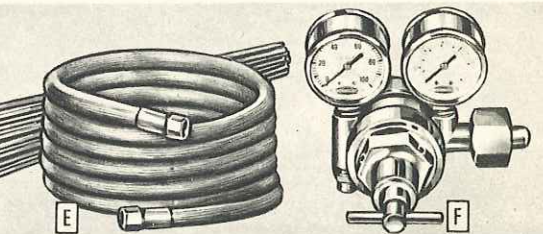
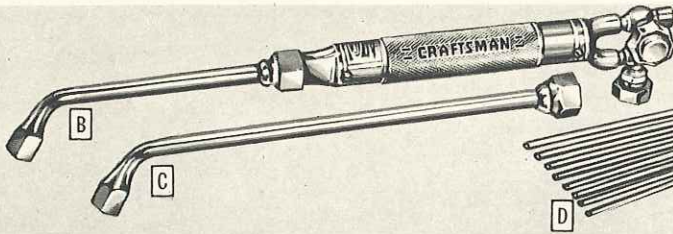
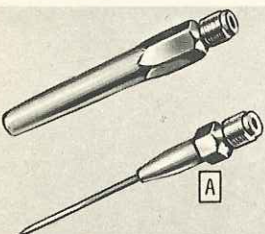
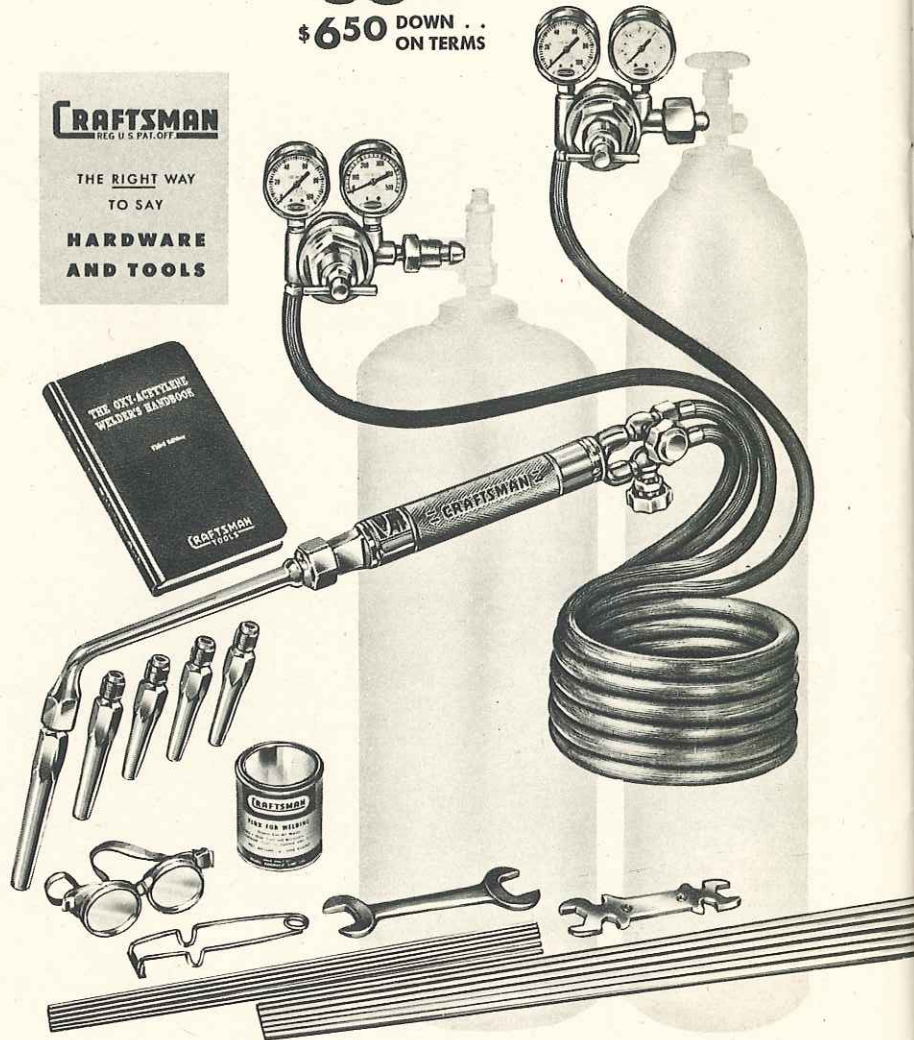

Welding Tips

A CRAFTSMAN. As supplied with above welding outfit. Interchangeable. Made by new "swaging" process from heavy, one-piece solid drawn pure copper containing minimum of lead and tin. Withstands extremely high (6000°F) oxy-acetylene flame temperatures. Highly polished. Shipping weight 4 oz. each. *State size wanted.*
9 T 5441 Each \$1.60

Size	Welding capacity; in.
AA-0	For soldering. . .
AA-1	1/16 to 1/8 in.
AA-2	3/16 to 1/4 in.
AA-3	1/2 to 3/8 in.
AA-4	3/8 to 1/2 in.
AA-5	1/2 to 3/4 in.
AA-6	3/4 to 1 in.
AA-7	1 to 1 1/4 in.
AA-8	1 1/4 to 1 1/2 in.

Welding Torch

B CRAFTSMAN. Model, A. 17 1/4 inches long. Bronze non-flash torch. Each
Gooseneck is solid bronze drop forging . . . will not bend. Permits you to cut steel, using 9 T 5444 cutting attachment, shown and described on the opposite page. Shipping weight 3 pounds.
9 T 5429 Each \$16.75

Mixing Chamber

C CRAFTSMAN. 12 inches long. Provides the longer mixing section that must be used when using the 9 T 5441 welding tips, sizes AA-6, AA-7 or AA-8, listed at the left. Solid drop forged bronze construction. Gooseneck type. Shpg. wt. 12 oz.
9 T 5443 Each \$6.50

Welding Rods

D CRAFTSMAN. 90 assorted rods. A complete selection of rods that permits you to do oxy-acetylene welding on bronze, cast iron, aluminum and mild steel. For most repair and production work, welding rod metal should be same as or similar in characteristics to metal being welded. (For example, mild steel rods on steel).
This assortment includes: four 1/8x18-in. Tobin bronze rods; four 3/16x18-in. Tobin bronze rods; thirty 3/32x18-in. mild steel rods; twenty-two 1/8x18-in. mild steel rods; twelve 3/16x18-in. mild steel rods; eight 1/4x18-in. drawn aluminum rods; and seven 1/4x24-in. cast iron rods.
9 T 5440—90 rods. \$4.50

1/4-inch Hose

E CRAFTSMAN. Tested to 800 lbs. per square inch. 12 1/2-ft. Working pressure 200 lbs. 1/4-inch inside diameter. One-braid construction with three tough layers. Rayon cord reinforcement stronger than usual cotton hose yarn. Super tough, heat and abrasion-resistant Neoprene cover. Threaded brass connectors. *State length:* 12 1/2 or 25-ft.
9 T 5437—Green Oxygen Hose, 12 1/2-foot length. Shpg. wt. 1 lb. 13 oz. \$1.80
25-foot length. Shipping weight 4 pounds. . . . \$2.95
9 T 5438—Red Acetylene Hose, 12 1/2-foot length. Shipping wt. 1 lb. 13 oz. \$1.80
24-ft. lgth. Wt. 4 lbs. . . . 2.95

Gas Regulators

F Guaranteed accurate! For oxygen and for acetylene.
9 T 5430 \$17.75
Oxygen Regulator. Two gauges: 0 to 80 and 0 to 3000 pounds. Dependable pressure indicators. Shpg. wt. 4 lbs.
9 T 5431 \$15.75
Acetylene Regulator. Two gauges: 0 to 80-pound and 0 to 500-pound pressures. Shpg. wt. 4 pounds.
9 T 5413—Adapter for Airco, Commercial or Searchlight tanks. Shipping weight 5 ounces. . . . \$1.45
9 T 5414—Adapter for Prest-O-Lite auto lighting tanks. Shpg. wt. 5 oz. \$1.65

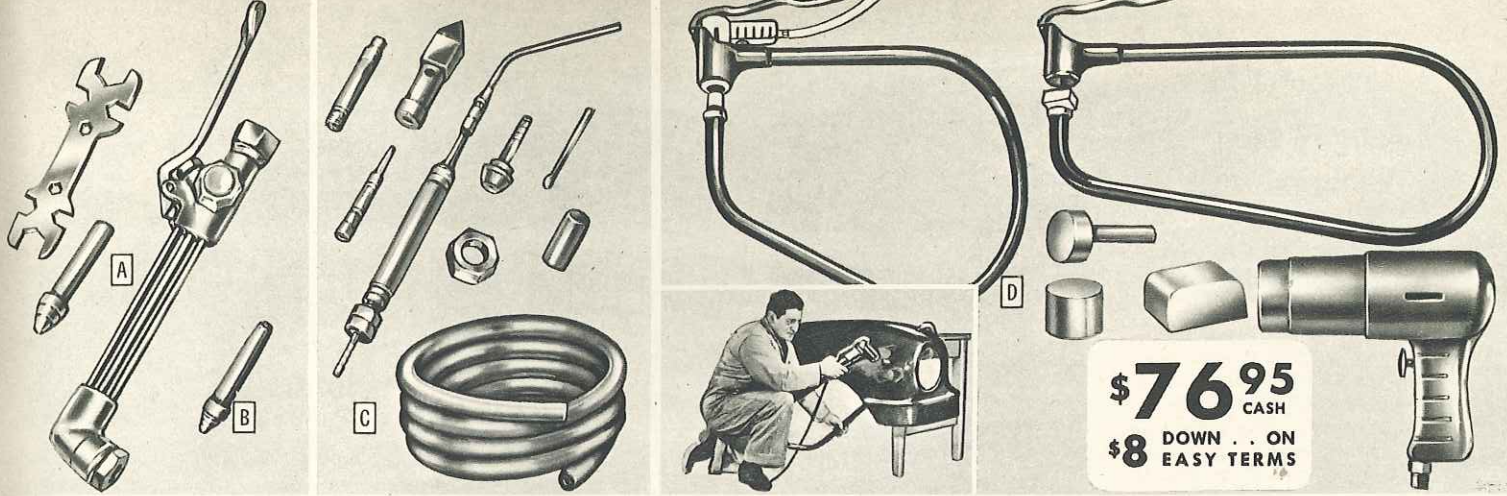

\$76⁹⁵
CASH
\$8 DOWN . . ON
EASY TERMS

Welding Needs . . . Body and Fender Tools

Cutting Attachment

A CRAFTSMAN. Replaces mixer on 99 T 05442 outfit on opposite page. One B-3 tip, wrench and instructions included.
9 T 5444—Shipping weight 3 pounds 6 ounces. . . . \$16.75

Cutting Tips

B CRAFTSMAN. For above cutting attachment. Shipping weight 6 oz. each. State size when ordering.
9 T 5447 Each \$2.35

Size	Cuts steel	Size	Cuts steel
B-1	up to 1/8 in.	B-4	1 1/2 to 4 in.
B-2	1/8 to 1/4 in.	B-5	4 to 6 in.
B-3	1/4 to 1 1/2 in.		

Brazing Outfit

C CRAFTSMAN. Professional heating, brazing and soldering outfit. Use with Prest-O-Lite cylinders. Operates on acetylene only; requires pressures up to 4 lbs. for largest tips. Do not use with oxygen or air pressure. Sturdy construction . . . will last for years if properly used!

Outfit includes: Handle; three heating tips; soldering copper; paint burning tip; tank connection; tip cleaner; 5 feet of rubber hose; and complete instructions.

9 T 5446—Shipping weight 2 pounds. \$6.50

CRAFTSMAN Pneumatic Body and Fender Set

D New, exclusive design! Features you'll find in no other outfit made! The most trouble-free set you can buy today. We think it's the finest body and fender set made—regardless of price! Built for extra heavy duty continuous service. Saves up to 70% of time ordinarily needed on body, fender and sheet metal work. Power unit detaches for use as pneumatic hand tool for chiseling, riveting, driving, etc. Pneumatic hammer has drop forged steel body; piston of ball bearing steel. All working parts heat treated and hardened. Gleaming chromium plated finish.

Check these four outstanding features of this tool: (1) *It's air lubricated* . . . needs no oil for lubrication. Free-floating piston actually glides on film of air, keeping hammer cool and clean. (2) *No delicate valves to pamper.* Dirt and scale which would clog ordinary air hammer blow out through large holes and exhaust port. Less air used, too, because air is used only for striking blow. Fatigue-resisting beryllium-copper spring returns piston to initial position after each stroke. (3) *"Easy Control" lever.* You can control pressure, speed and power without changing hand position . . . change power unit from one arm to the other without disconnecting hose or undoing any screws or nuts. You can move the tool over humps and irregularities without complicated adjustments. (4) *Safer because tool can't accidentally fly out of gun with tool off work.* No beehive spring!

Set includes: Two 1 5/16-inch tubular steel arms (one 20x23 in.; other 18x30 in.); 3/8-inch long pneumatic hammer; one upper dolly; two lower dollies. Use 90-lb. air supply at 10 C.F.M.

99 T 02510—Pneumatic Body and Fender Set. With instructions. Shpg. wt. 33 lbs. Set \$76.95

Sensational post-war improvements give CRAFTSMAN Air Hose super-strength!

Just look at the way this air hose is built! Three tough layers: (1) *Special rubber inner tube* that's not affected by oil or similar solvents. (2) *New rayon cord reinforcement* . . . the same rayon cord used in newest heavy duty truck tires . . . actually TWICE as strong as ordinary horse yarn! Tests prove this CRAFTSMAN hose with one-braid rayon cord reinforcement is stronger than ordinary two-braid hose. Maximum working pressure 250 lbs. (3) *New super-tough Neoprene cover* gives greater resistance to sun, heat, oil, chemicals and abrasion than hose with old-style rubber covers.

Ideal for use with all pneumatic tools; for air lines on spraying equipment; for tire inflation; for cleaning with compressed air; for use wherever air or non-corrosive gas is conducted. Complete with standard couplings.

E With brass couplings. 15 or 25-foot lengths. 9 T 1875—15-foot length; 3/4-inch inside diameter. Shpg. wt. 1 lb. 12 oz. \$1.89
9 T 1876—25-foot length; 5/16-inch inside diameter. Shipping weight 4 lbs. 8 oz. \$2.98

Also available by the foot without couplings. Any desired length up to 500 feet in one piece. State length wanted.

Catalog number	Inside diameter	Shipping weight per foot	Price per foot
99 T 08800	3/16 inch	2 ounces11c
99 T 08801	1/4 inch	2 ounces12c
99 T 08802	5/16 inch	3 ounces13c
99 T 08803	3/8 inch	3 ounces15c

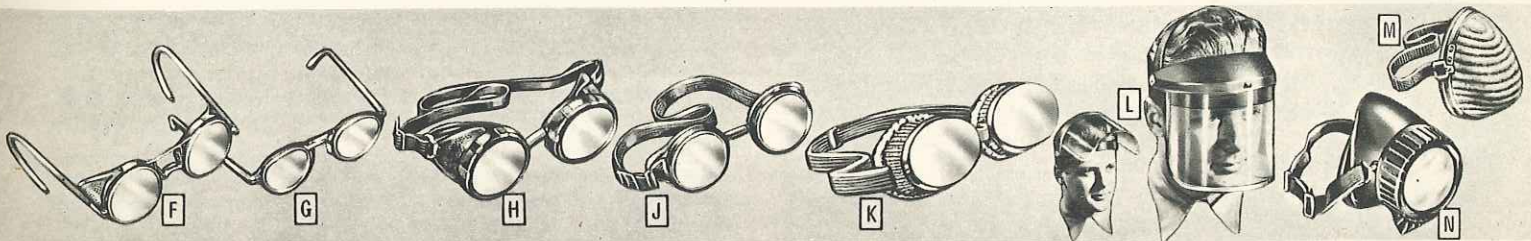
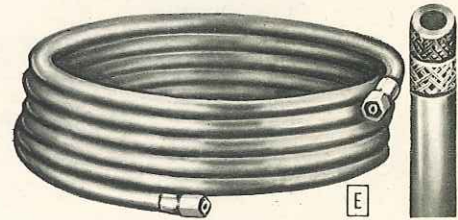

Spectacle type Safety Goggles

F With side shields. For grinding, chipping and hazardous work. Both frontal and side protection. Ample ventilation minimizes fogging. Non-corroding frame; wire mesh side shields. Insulated temple pieces. Heat and perspiration resistant. Adjustable nose piece. Clear, hardened, ground 50-mm. lenses. 28 T 6070—Shipping weight 8 ounces. \$1.59

G Lightweight type. No side shields. Crystal clear 44-mm. flat lenses. Full angle vision. Non-inflammable plastic frame. Wire cored padded temples. 28 T 6067—Shipping weight 5 ounces. \$1.49

Industrial type Safety Goggles

H For chipping and grinding. Eye protection from flying particles coming from all directions. Clear 50-mm. lenses hardened and ground. Wide angle vision. Composition frame; adjustable headband. 28 T 6060—As described. Shipping weight 9 oz. . . . \$1.79
28 T 6061—Similar to above, but larger, to fit over regular glasses. Shipping weight 12 oz. 1.98

Replacement 50-mm. Lenses. Not shown. Clear glass, hardened and ground. For 28 T 6070, 28 T 6060 and 28 T 6061. 28 T 6088—Shipping weight 3 oz. per pair Pair 59c

Welders' Goggles

J Shade 5 lenses. For light acetylene welding, cutting. Elastic headband; adjustable bridge. Ventilated side shields; no fogging. Screw caps for changing lens or cover glass. 28 T 6053—Shpg. wt. 4 oz. \$1.89

K Over-spectacle style. Worn over regular glasses. Similar to 28 T 6053. 28 T 6054—Shpg. wt. 12 oz. \$2.29

L Extra 50-mm. Filter Lenses for above. No. 4 density. For average acetylene welding, cutting, brazing, etc. 28 T 6055—Shpg. wt. 3 oz. Pair 69c
No. 6 density. Extra dark. For heavy acetylene welding, cutting, etc. 28 T 6057—Shpg. wt. 3 oz. Pair 69c

M Dust and Wind Goggles. Cloth sides filter out dust, prevent fogging. Chenille bound edges. Shatter-proof glass lenses. 28 T 6068—Shpg. wt. 4 oz. \$1.45
Similar to above. Plain glass lenses. 28 T 6062—Shpg. wt. 4 oz. 59c

Plastic Face Shield

L Protects eyes and face. Adjustable. Metal-bound window of non-inflammable plastic snaps onto shield. Sweatband; eye shade. 10 3/4 x 6 in. 28 T 6085—Shipping weight 1 lb. \$1.89
28 T 6086—Extra Window for above. Shpg. wt. 8 oz. 79c

Low-cost Respirator

M Protects against pollens and dust from processing wood, grain, stone and metal. Comfortable molded rubber frame. 28 T 6087—As described above. Shpg. wt. 8 oz. \$1.49

Industrial Respirators

N For all dust hazards—mineral, agricultural, etc. See below for fumes and vapors. Positive protection. Air-tight fit. Valve can't stick open. Sanitary, easy to clean. Pliable, non-irritating rubber face mask. Easily replaceable filter. 28 T 6073—As described above. Shpg. wt. 12 oz. \$2.98
28 T 6074—Extra Filter for above. Shpg. wt. 5 oz. 98c

For low concentration fumes and vapors such as paint spraying, dry cleaning, gasoline, benzene, etc. Design similar to 28 T 6073 described and shown above. Easily replaceable filter included. 28 T 6081—As described above. Shpg. wt. 12 oz. \$2.98
28 T 6084—Extra Filter for above. Shpg. wt. 5 oz. Each 59c

WARNING: Respirators cannot and should not be used as gas masks.



Learning to weld is easy!

Save time and money; do your own welding. It's easy to learn how! Each CRAFTSMAN Arc Welder Outfit includes a booklet of easy-to-follow instructions plus a generous supply of practice welding rods. Read the directions ... get a little practice ... soon you'll be able to weld well enough to do 95% of your repair jobs!



\$199⁰⁰ CASH
\$20 DOWN... ON EASY TERMS

\$150⁰⁰ CASH
\$15 DOWN... ON EASY TERMS

CRAFTSMAN Industrial Arc Welders

Built to the highest standards for continuous service

Buy a CRAFTSMAN and be SURE you're getting one of the finest electric arc welders made! Just look what you get.

- 1** A complete range of welding currents for every kind of work—welding, cutting, brazing, soldering or heating.
- 2** Greater efficiency and reduced current consumption because the welder transformer has a high power factor.
- 3** A welder that's almost impossible to burn out when used at correct voltage! That's because the windings are insulated with spun glass ... the finest insulation used in arc welders today! Coils dipped in varnish and baked.
- 4** A steady arc at ALL heats. Built-in reactance automatically increases voltage at low heats.

5 A safer welder ... one that's approved by Underwriters' Laboratories, Inc. ... one that meets all their standards for safety, freedom from fire hazard and maximum temperature rise. Natural draft cooling ... no fans used. Cooler operation even under continuous service! Fire-resistant all-metal cabinets. Control panel fully protected against dust and dirt. Approved code-type switch. Stub wire leads for power line connection.

6 Accessories: 5 lbs. of assorted welding electrodes, wire brush, carbon electrode, electrode holder, two 15-foot cables, welding helmet and instructions.

For use on single phase 220-230 volt 60-cycle A.C. only. Important: Before ordering, please check voltage, cycle, phase and capacity of your power line with local power company.

CRAFTSMAN 300-ampere A.C. Arc Welder

(Above at left.) The finest industrial welder we have ever sold! Extra heavy duty. Meets rigid requirements for professional use and production work. Especially suitable for factories, mills, foundries, welding shops, construction companies, etc. where heavy work is repaired or fabricated.

SPECIFICATIONS:
 Maximum amperes actual welding current delivered.....300 amperes
 Welding heats available (actual welding current).....Thirty; 20 to 300 amperes
 Maximum rod size..... $\frac{1}{4}$ inch
 Type of service.....Continuous heavy duty
 Current supply required.....Single phase 220-230 volts 60-cycle A.C. only
 Maximum open circuit secondary volts.....94 volts
 Maximum line draw.....65 amperes
 Maximum kilowatts.....8.2 kilowatts
 Maximum kilo-volt-amperes.....14.3 kilo-volt-amperes
 Cabinet dimensions: 37 inches high; 21 inches deep; 23 inches wide. Casters in front, wheels in rear.
 99 TM 2015—Complete as described. Shipping weight 330 lbs..... **\$199.00**

CRAFTSMAN 200-ampere A.C. Arc Welder

(Above at right.) Smaller capacity than 300-ampere model at left but still more than ample for steady continuous service in garages, mills, factories, body and welding shops, etc. Especially recommended for repair or production work. Gives maximum heat at the arc with minimum current consumption.

SPECIFICATIONS:
 Maximum amperes actual welding current delivered.....200 amperes
 Welding heats available (actual welding current).....Eighteen: 20 to 200 amperes
 Maximum rod size..... $\frac{3}{16}$ inch
 Type of service.....Continuous
 Current supply required.....Single phase 220-230 volts 60-cycle A.C. only
 Maximum open circuit secondary volts.....94 volts
 Maximum line draw.....48.5 amperes
 Maximum kilowatts.....6.2 kilowatts
 Maximum kilo-volt-amperes.....10.7 kilo-volt-amperes
 Cabinet dimensions: 33 inches high; 20 inches wide; 21 inches deep. Casters in front, wheels in rear.
 99 TM 2012—Complete as described. Shipping weight 260 lbs..... **\$150.00**

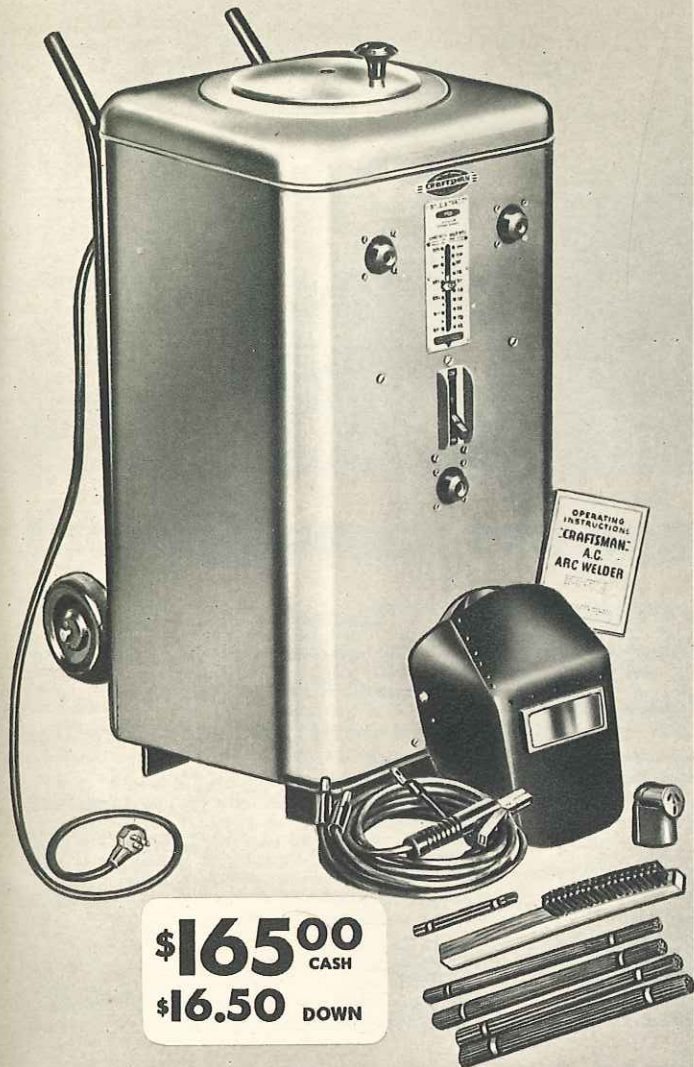

\$165⁰⁰ CASH
\$16.50 DOWN

CRAFTSMAN Arc Welder

Complete! Ready to plug in and weld

Farmers, garage, small welding and industrial shop men . . . here's your welder! Perfect for R. E. A. and other rural power lines and also city shops where local distribution transformer has capacity of 3 K.V.A. or more. Welds, cuts, brazes, heats and solders all thicknesses of metal.

Compact, portable, ready to use. Completely assembled and wired. Plug it in and weld! Two 6-inch diameter wheels and hand truck type handles for moving. Stepless current control . . . continuously adjustable from 20 to 150 amperes. Change heats under load without stopping work, or preset welder before you start. Visual current indicator permits current control to within 1/2 ampere. No cables or terminals to touch. Just rotate hand wheel on top of unit!

Safer construction: Meets N.E.M.A. and R.E.A. standards. Approved by Underwriters' Laboratories, Inc. No exposed terminals or switches. Strong all-metal cabinet fully encloses unit. Transformer has high power factor . . . needs no capacitor. Transformer highly insulated with low-volt secondary completely isolated, electrically and mechanically, from high-volt primary. All coils permanently mounted—current carrying parts not moved when adjusting amperage. Carefully inspected and factory tested. Approved code-type switch.

Spun glass insulation. Flameproof; safe even at high temperatures. Coils dipped in special varnish, then baked for complete burnout protection. Natural draft ventilation keeps coils from overheating . . . no fans used!

Includes: two work cables (12-ft. ground cable; 18-ft. electrode cable); assorted electrodes; electrode holder; steel brush; helmet; and instructions. For use on single phase 220-230-volt 60-cycle A.C. only. Check voltage, phase, cycle and capacity of your line with local power company before ordering.

SPECIFICATIONS:

- Maximum amperes actual welding current delivered 150 amperes
 - Welding heats available 20 to 150 amperes; continuously adjustable
 - Maximum open circuit secondary volts 60 volts
 - Maximum rod size 5/32 inch
 - Type of service Intermittent
 - Current supply required 220-230 volts, single phase 60-cycle A.C. only
 - Maximum line draw 37 amperes at 230 volts
 - Maximum kilowatts 5.4 kilowatts
 - Maximum kilo-volt-amperes 7.7 kilo-volt-amperes
- Cabinet dimensions: 38 1/2 in. high; 18 1/4 in. wide; 26 in. deep.
 99 TM 2010—Complete as described. Shipping weight 350 lbs. \$165.00



CRAFTSMAN Twin Carbon Torch

Industrial type. Doubles usefulness of any A.C. arc welder. Faster, easier, better brazing, soldering, heating. Ideal for work on thin metals. Lightweight; balanced. With cables, carbons, instructions. **\$1595**
 9 T 2007—Length 15 1/4 inch. Shpg. wt. 4 lbs. 6 oz. \$15.95

Cored Carbons for Twin Torches

Catalog number	Diameter	Length	Shipping weight	Each
9 T 2020	1/4 inch	6 inches	2 ounces	10c
9 T 2021	5/16 inch	6 inches	2 ounces	12c
9 T 2022	3/8 inch	6 inches	2 ounces	15c

CRAFTSMAN Electrode Holder

\$298
 Fully insulated. Light in weight. Rods quickly changed. For welders with capacity of 300 amperes or less. 9 in. long.
 9 T 2006—Shipping weight 1 pound. \$2.98

Dependable Welding Helmets

\$775
 One piece seamless vulcanized fiber construction. Shaped to fit head contour. Fiber head band adjustable over wide range of sizes. No metal touches head. Friction joint adjustable from outside for free-floating action. Bakelite glass holder. 2x4 1/2 inch clear cover glass provided. Filter lens not provided. See below.
 9 T 1324—Shipping weight 2 lbs. 6 oz. \$7.75

\$625
 Streamlined fabricated fiber construction. Helmet has automatic spring snap for "off" and "on" positions. Black fiber headband with genuine leather sweatband. Size adjustable over wide range. No metal touches head. Convenient glass holder keeps cover glass and filter lens in place yet readily removable. 2x4 1/2 inch clear cover glass supplied; filter lens not included. See below.
 9 T 1323—Shipping weight 2 lbs. 9 oz. \$6.25

\$345
 Fabricated fiber construction. Adjusts to fit head size. Can be thrown back without removing from head. Friction joint between headband and helmet make helmet readily adjustable and secure in both "on" and "off" positions. Clear cover glass and No. 10 density filter lens provided. Both are 2x4 1/2-inch size. Note our low price!
 9 T 1326—Shipping weight 2 lbs. 8 oz. \$3.45

Extra Filter Plates and Cover Glass. Not illustrated. For arc welding use. Size 2x4 1/2 inches. Fit almost all helmets. Shipping wt. of each is 5 oz.
 9 T 1327—No. 10 shade Filter Plate. For 75 to 250 ampere welding work. 87c
 9 T 1328—No. 12 shade Filter Plate. For 250 ampere or over welding work. 87c
 9 T 1329—Clear Cover Glass. 6c

Electrode Assortment

\$550
 CRAFTSMAN. Handy 20-pound assortment of welding rods for general utility work. About 380 rods in all. Assortment includes types and sizes for most general purpose welding jobs. For use with A.C. or D.C. welders (D.C. reverse polarity). Assortment includes: Rods for mild steel welding; 2 lbs. of 3/32-inch rods; 4 1/2 lbs. of 1/8-inch rods; and 4 1/2 lbs. of 5/32-inch rods. Rods for cast iron welding; 4 1/2 lbs. of 1/8-inch diameter rods. Rods for hard surfacing; 4 1/2 lbs. of 1/8-inch rods.
 99 T 02024—Complete assortment. Shipping weight 22 pounds. \$5.50

Welding Electrodes

\$
 CRAFTSMAN. Individual types for specific purposes. Specially flux-coated for use on all A.C. or D.C. (D.C. reverse polarity) welders. Easy striking; assure minimum spatter loss and easy slag removal. Shipping weight of 5-lb. size is 5 lbs. 12 oz.; 25-lb. size, 29 lbs. Order by catalog number and state size needed.

9 T 2003—General purpose type recommended for use on mild steel. Please state size wanted.

Size	5 lbs.	25 lbs.
3/32-inch	\$1.39	6.60
1/8-inch	\$1.05	4.90
5/32-inch	\$0.98	4.60
3/16-inch	\$0.95	4.40

9 T 2055—For use on cast iron. State size.

Size	5 lbs.	25 lbs.
3/32-inch	\$1.49	6.95
1/8-inch	\$1.19	5.60
5/32-inch	\$1.05	4.90
3/16-inch	\$0.98	4.60

9 T 2004—For hard surfacing. State size.

Size	5 lbs.	25 lbs.
1/8-inch	\$2.79	13.50
5/32-inch	\$2.65	12.75
3/16-inch	\$2.49	12.00

For Sears Easy Terms see inside back cover.

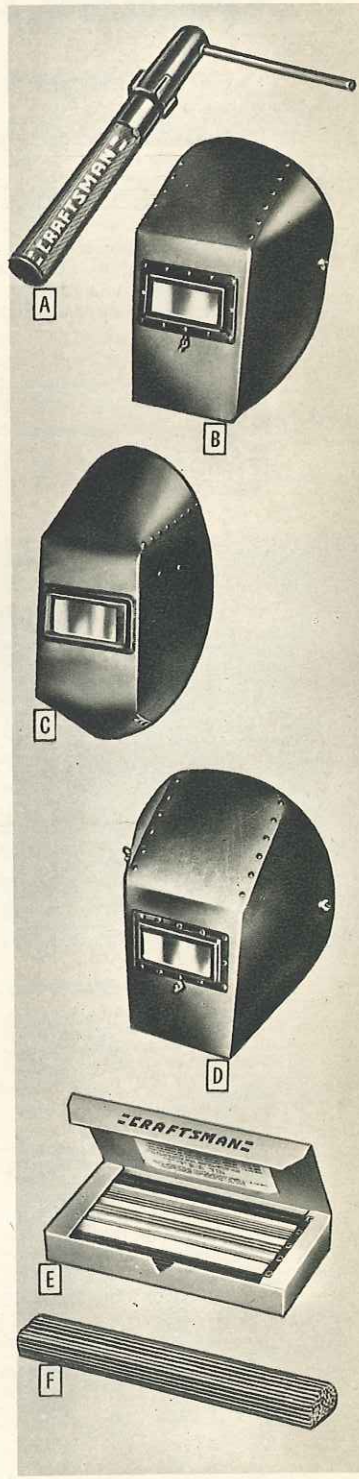

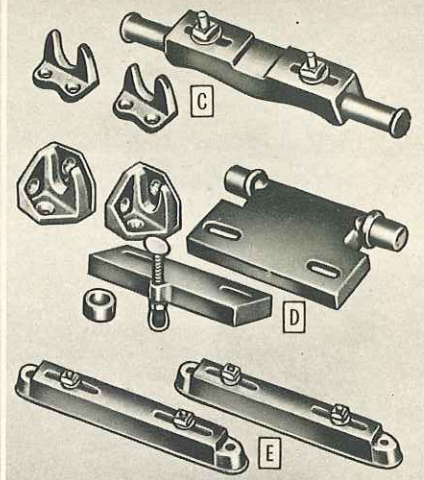
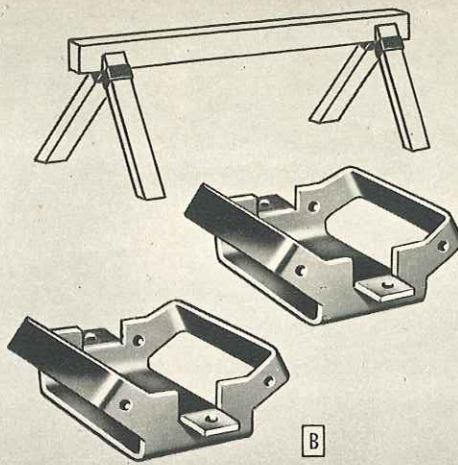
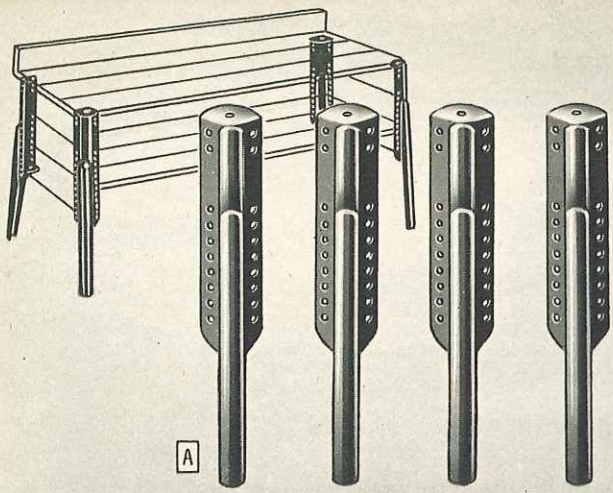

Quality Accessories for your power equipment

CRAFTSMAN Bench Leg Set

A Now you can build a strong, rigid work bench, machine table or lathe bench with CRAFTSMAN steel legs and your own lumber. In this way, you can own a rugged well-made bench, built to your own specifications, at an exceptionally low price. Each leg is made from one piece of extra heavy cold rolled steel; punched at top for attaching to bench top. Bottoms are punched for fastening to floor, to make work bench stationary, or for attaching casters. Each leg has perforations, enabling you to install a lower shelf or cross braces (stringers) at six different heights. Side boards may be added.

Set includes 4 steel bench legs with shelf support brackets; lag screws for fastening legs to bench top; cadmium-plated bolts, lock washers and nuts for fastening brackets, and instructions for assembling. Gray enameled finish. Wood parts are not included.

- 99 T 02732—Height, 26 inches. Shipping weight 17 pounds.
Set of 4 legs..... **\$6.25**
99 T 02731—Height, 31 inches. Shipping weight 18 pounds.
Set of 4 legs..... **\$6.25**

\$6.25
Set of 4

Sawhorse Brackets

B Make your own sawhorses quickly and easily—set up tables, platforms, etc. Brackets made of heavy gauge, rust-resistant plated steel. Electrically welded into one solid unit for strength and rigidity. Wedge-shaped design enables brackets to stand tremendous weight. The more weight applied, the tighter frame becomes.

With these brackets you can quickly dismantle your sawhorse. Brackets can be used again and again. All you need is a set of brackets and your own lumber. For use with 2x4's. Lumber not included. Shpg. wt. 3 lbs.

- 9 T 2889.....Set of 2 for **\$1.49**

\$1.49

CRAFTSMAN Motor Rails

C Floating Motor Rail. Use one motor for several tools! Just fasten clips near each tool, and shift motor with rail where needed. With one pair of clips.

- 9 T 2275—Shipping weight 1 lb. 13 oz.....Set **\$1.15**
9 T 2277—Pair clips only. Shpg. wt. 7 oz..... **.40c**

\$1.15
Set

D Deluxe Floating Motor Rail. All the advantages of ordinary rails... plus support for rear end of motor, rubber cushioning, and right angle clips. Clips allow motor to be mounted either behind or under tool. Rear rail pivot support carries rear end of motor.

- 9 T 2326—Shipping weight 2 pounds.....Set **\$2.09**
9 T 2328—Pair clips only. Shipping wt. 10 oz..... **.60c**

E Adjustable Motor Rails. Use where motor is not to be removed. To adjust belts, just loosen bolts, slide motor for belt tension wanted; then tighten bolts.

- 9 T 2279—Shipping weight 3 pounds..... Per pair **\$1.49**

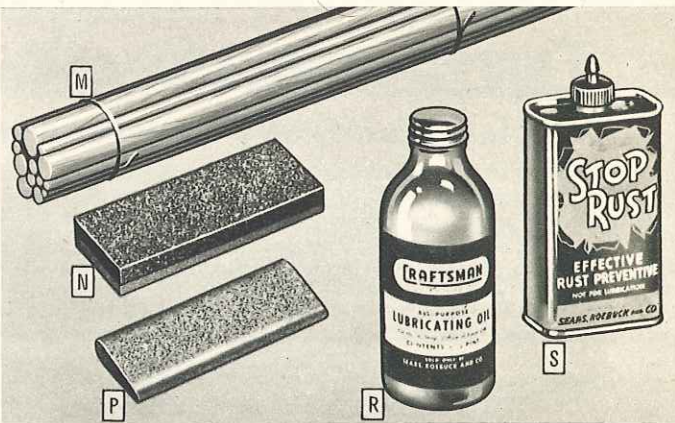
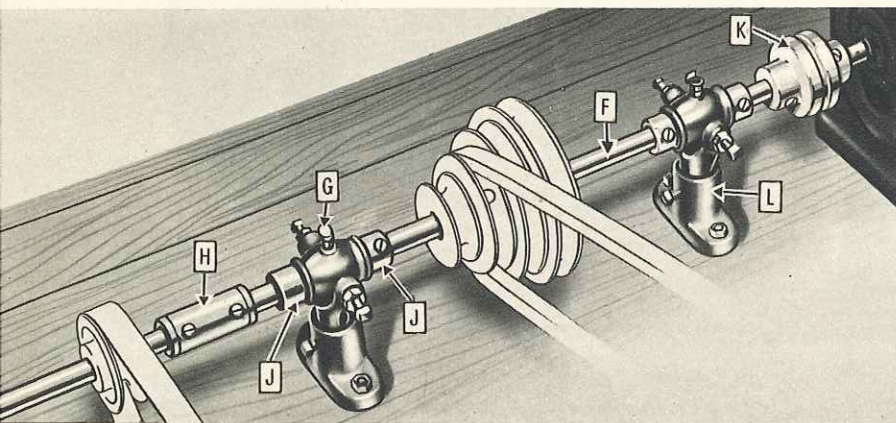

Line Shaft Accessories... accurately machined

A line shaft is used to drive a group of power tools from one permanently mounted motor. In such a setup, there is always some loss of power in the various belts and bearings. Because of this, we recommend a 1/2-H.P. motor or larger to drive a line shaft. The exact H.P. will depend on the number and type of tools, length of shaft, etc.

Accessories listed below are of very high quality. In some shops, floating rails (listed above) will prove more flexible and practical. We suggest you consider both setups.

Line shafts come in two sizes: 1/2-inch for light tools; 3/4-inch for heavier machines and larger motors. Oil cups easily installed in place of plugs.

Make sure bushings receive proper oiling. Rigid couplings frequently are used for connecting sections of line shafting. Line shaft collars prevent endwise "drift" of shaft. Flexible couplings are used on such jobs as connecting a motor shaft to a line shaft. Self-adjusting for minor misalignment, thus preventing excessive bearing wear. Bronze bearing hangers are adjustable to permit perfect shaft alignment. 1/2-inch hangers should be spaced every 18 inches; 3/4-inch hangers every 24 inches.

When your line shaft is set up, oil freely, and be sure it is perfectly in line and turns easily before turning on the motor. Will help give you longer, trouble-free service.

	Catalog number	Description	Shpg. wt.	Each
F	9 T 2833	1/2-inch x 24-inch Steel Shaft	1 lb. 15 oz.	\$0.35
	99 T 02834	3/8-inch x 48-inch Steel Shaft	3 lbs.	.67
	99 T 02835	3/4-inch x 48-inch Steel Shaft	7 lbs.	1.45
G	9 T 2820	Oil Cups	1 oz.	.07
H	9 T 2839	1/2-inch Rigid Coupling	5 oz.	.35
J	9 T 2824	1/2-inch Line Shaft Collar	2 oz.	.12
	9 T 2825	3/4-inch Line Shaft Collar	3 oz.	.19
K	9 T 2840	Flexible Coupling (Specify 1/2, 3/8 or 3/4 inch)	12 oz.	.65
L	9 T 2828	1/2-inch Bronze bearing Shaft Hanger	1 lb. 8 oz.	1.50
	9 T 2829	3/4-inch Bronze bearing Shaft Hanger	1 lb. 12 oz.	1.98

Handy Wood Dowel Assortment

- M** For model building, furniture mending, etc. 14 sizes, 1/4 to 3/4-inch diameter. Each rod 16 inches long. Clear-grain hardwood.
9 T 2909—Shipping weight 14 ounces.....Pkg. of 14 for **39c**

CRAFTSMAN Combination Sharpening Stone

- N** Keep your tools sharp. Vitrified silicon carbide. Fine grit one side; coarse grit other side. Please state size.
9 T 6440—Size 5x2x1/4 inch. Shipping weight 12 oz..... **\$1.10**
Size 6x2x1 inch. Shipping weight 1 lb. **1.45**
Size 7x2x1 inch. Shipping weight 1 lb. 8 oz..... **1.75**

Medium Fine Slip Stone

- P** DUNLAP. Round edge. For gouges and other round shaped tools. Size 4x1 1/4 inches; taper from 1/2 to 3/16 inch.
9 T 6454—Shipping weight 12 ounces..... **69c**

CRAFTSMAN Lubricating Oil

- R** For electric motor and general shop use. Will not gum or become sticky. Please state size wanted when ordering.
9 T 6547—1/2 pint. Shipping weight 8 ounces..... **19c**
1 pint. Shipping weight 1 pound..... **29c**

Stop-Rust... safe to handle

- S** DUNLAP. Protects tools from rust. Gives effective protection to metal surfaces where painting isn't desirable. Can be brushed, sprayed, or dipped on. Non-inflammable. 8-oz. can.
9 T 2927—Shipping weight 9 ounces..... Each **29c**

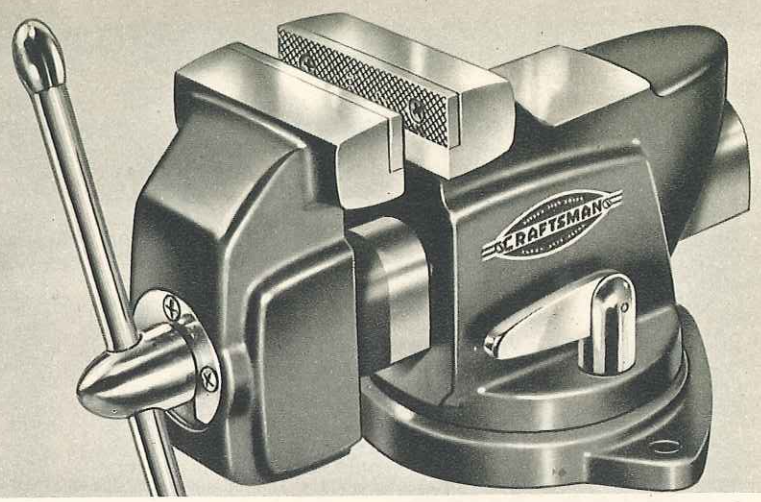
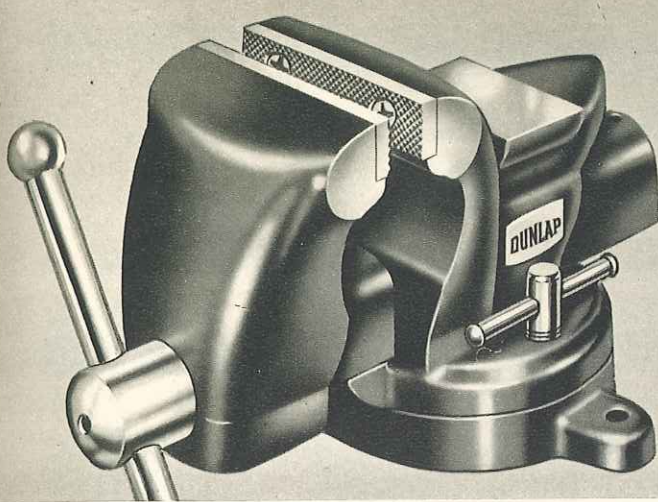

Bench Vises . . . extra Heavy Construction

DUNLAP Bench Vise . . . good quality priced low

Don't be misled by Sears low price! You'd expect to pay much more for a sturdy, well-made vise like this. There's rugged, heavy-duty quality built into every detail. Has everything a good bench vise should have . . . precision workmanship, extra weight, and added strength. This means better performance and longer life in your shop or garage.

\$650

Husky, semi-steel body . . . much stronger than cast iron . . . strongly reinforced at all points of strain. Oversize cold rolled steel U-shaped slide beam fits snugly, yet slides easily; jaws won't wobble . . . prevents filings and foreign matter from wearing threads. Smooth working Acme-threaded steel screw has more threads per inch for a tighter grip.

Replaceable, oil-tempered and hardened steel jaw faces have deep-cut knurls to assure a firm, strong grip on materials . . . hold objects rigidly regardless of shape. The 3½-inch jaws open to 4¼ inches.

Swivel base turns left or right a full 180 degrees . . . has positive-locking 3-point contact . . . locks securely in any position. Durable, rust-resisting red crackle finish. Actual weight 15¼ pounds.

99 T 05244—Shipping weight 17 pounds. Mailable **\$6.50**

CRAFTSMAN Bench Vise . . . professional quality

By far the finest vise of this type we've ever sold! You'll have an entirely new idea of vise quality when you see this superb new design and try its exceptionally smooth, easy action. Really a beauty to look at . . . built for extra heavy duty . . . packed with rugged brute strength in every part. Body is strongly reinforced at all points of strain. All parts precision-machined; complete interchangeability is possible.

\$1250

Hardened and tempered, deep-knurled jaw faces are replaceable to permit longer vise life . . . keep a firm, strong grip on the work. Cold rolled steel "U" beam slides easily . . . fits snugly . . . prevents jaw wobble. Beam completely covers the screw to protect it against dirt and filings . . . helps maintain the exceptionally smooth, easy action. Acme-threaded steel screw has 6 threads per inch.

New-type, oval-shaped stops at ends of the handle help prevent pinched fingers. Convenient, new-type handle on swivel base eliminates the nuisance of a sliding bar. Swivel base turns full 360 degrees . . . locks at any desired angle. Gray enamel finish; jaws, beam, anvil and handles are highly polished.

99 T 05176—3½-inch jaws open 5 inches. Shpg. wt. 29 lbs. Mailable **\$12.50**
99 T 05169—4 -inch jaws open 5 inches. Shpg. wt. 35 lbs. Mailable 14.50

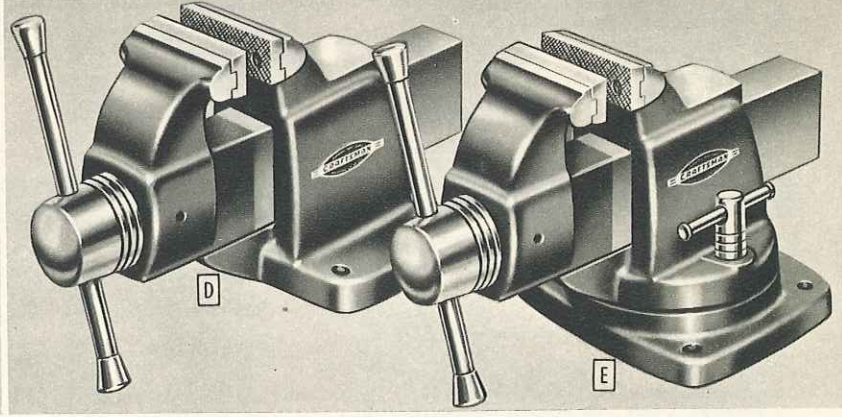
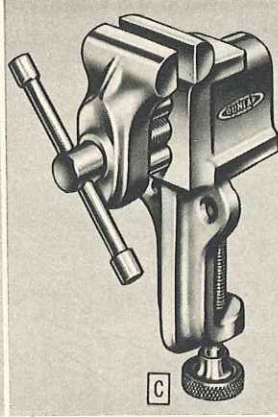
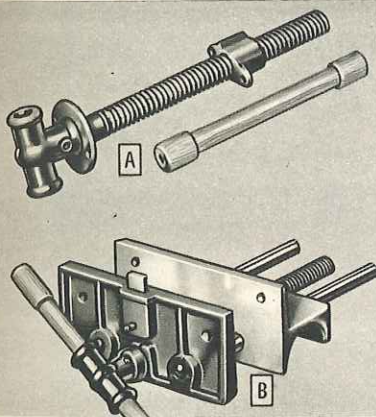

Bench Screw with Handle

A For replacement in old, worn-out bench vises, or making new woodworkers' vises, fruit presses, etc. Strong steel screw; Acme-cut threads. Standard 15½-in. length. 14-in. hardwood handle. 9 T 6662—Please state size wanted. 1-inch diameter screw. Shipping weight 5 pounds 8 ounces. **\$1.75**
1½-inch diameter screw. Shipping weight 6 pounds 10 ounces. **1.85**

Woodworkers' Vise

B CRAFTSMAN. Heavy semi-steel front and back jaws; smooth ground faces; holes for fastening wood faces to jaws if desired. Adjustable bench stop on front jaw. Acme-threaded steel screw assures smooth accurate movement of the jaws. 10-inch jaws; open to 10 in. 99 T 05200—Shpg. wt. 20 lbs. . . **\$10.95**
Quick-acting Woodworkers' Vise. (Not shown.) Similar to above, but half turn of handle disengages screw; permits jaw to slide back and forth. Turn in opposite direction again engages screw. 99 T 05201—Shpg. wt. 20 lbs. . . . **\$12.95**

DUNLAP Clamp Vise

C A splendid little vise for home, shop or farm. Ideal for the repairman who has to carry tools around on the job . . . for the model maker . . . or for anyone who works in limited space. Easily clamps to bench or table up to 2 inches thick. Twin-guide rod construction and clean-cut screw assure smooth action. Jaws and body of cast steel. Machined jaws meet squarely and give a firm grip. Jaws 1½ inches wide; open 2 inches.
Over-all height (with clamp closed) about 6 inches. Over-all width (with jaws closed) about 4 inches. 9 T 5245—Shipping weight 2 pounds 8 ounces. . . **\$1.65**
9 T 5247—(Not shown.) As above, but larger. Jaws 2½ in. wide; open 2½ in. Shpg. wt. 4 lbs. 8 oz. **\$2.95**

CRAFTSMAN Industrial Machinists' Vises

\$1650 Tremendously improved! So well made, we can positively guarantee them for 20 years against defects in materials and workmanship! Professional quality . . . especially constructed for daily service and heaviest machine shop work. You won't find a better machinists' vise in this price range anywhere else.

\$2100 CASH
99 T 05195
\$2.50 DOWN

Beautiful streamlined design. Semi-steel construction for greatest strength, reinforced at all points of strain. Alloy steel facings on jaws are replaceable to prolong life of vise; deep-knurled to hold work of any shape more firmly. All parts precision-machined for a snug fit, and to provide complete interchangeability. Heavy milled beam fits snugly; slides smoothly in double-broached rectangular hole through body. Head and collar bearings are machined to lessen screw wear. Three separate precision adjustments to take up end play and wear. Screw and handle are cold rolled steel. No pinched fingers, with new tapered ball ends and internal spring that prevents handle from dropping.

Machined base insures smooth bearing surface; jaws are always parallel to work bench . . . 4 anchor holes instead of only 3 eliminate all danger of vise working loose from the bench. Swivel-base model turns full 360 degrees; has cog swivel base lock and base track that locks positively in any position desired; gives just as much rigidity as solid base vise. All vises listed below have polished anvil surface for flat work. Two oil holes.

D CRAFTSMAN Solid Base Machinists' Vises				
Cat. no.	Jaws	Open	Shpg. wt.	Each
99 T 05190	3½-in.	5½ in.	32 lbs.	\$16.50
99 T 05191	4 -in.	7 in.	45 lbs.	17.95

Shpg. wts. above and right, are also actual wts. Sizes over 70 lbs., freight or express.

E CRAFTSMAN Swivel Base Machinists' Vises				
Cat. no.	Jaws	Open	Shpg. wt.	Each
99 T 05195	3½-in.	5½-in.	42 lbs.	\$21.00
99 T 05196	4 -in.	7 -in.	57 lbs.	24.75
99 TM 5197	4½-in.	8 -in.	72 lbs.	29.50
99 TM 5198	5 -in.	8½-in.	95 lbs.	42.90

Why not pay for your equipment while using it? See inside back cover for details on Sears Easy Terms

"EASI-BILD" full size Patterns

Just 3 simple steps . . . save money, time and effort . . .



TRACE

Place pattern on wood and trace with pencil



CUT OUT

Saw along traced lines with power or hand saw



ASSEMBLE

Put together according to easy-to-follow directions

NOW YOU can easily make your own household equipment, toys for the children, lawn or porch furniture, and gifts for your friends . . . with "Easi-Bild" full size Patterns. Build your own home, garage, poultry house and many other necessary out-buildings by using "Easi-Bild" Patterns.

Here's the ideal way to save money and have fun doing it. You'll have a great time making any of these things. Anyone who can drive a nail can build them. It's that simple! "Easi-Bild" Full Size Patterns take all the mathematical mystery out of building furniture, toys, etc. It's the dress pattern idea applied to the flat surface of lumber.

Just three simple steps as described above . . . trace, saw and assemble. No hard-to-read blueprints . . . no puzzling scale drawings . . . but, actual full-size patterns. Every pattern contains a list of needed materials, recommended kind of wood, easy-to-follow, step-by-step directions and assembly illustrations . . . even shows you where to use screws, nails, bolts, etc.

The many things YOU can build with these patterns are shown on these pages, set up. Look them over carefully now and decide the patterns you want. Lumber and materials not included. Price and pattern number listed below each pattern. Postpaid. (Shipping weight 6 ounces.)

9 T 2990—"Easi-Bild" Full Size Patterns. State pattern number wanted.

BIRD HOUSES

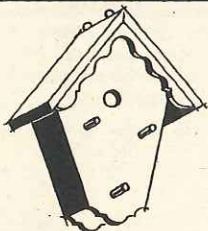

No. 111 Wren House . . . 15c



No. 11 Wren House . . . 20c



No. 69 Martin House . . . 50c

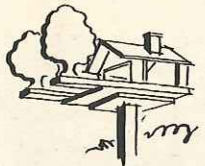

No. 9 Bird Feeder . . . 20c



No. 110 Bluebird House . . . 20c



No. 10 Bird House . . . 20c

LAWN AND PORCH FURNITURE



No. 56 Foldaway Chair . . . 25c

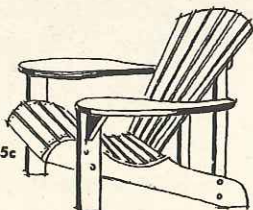

No. 32 Lawn Chair . . . 25c



No. 55 Foldaway Settee . . . 35c

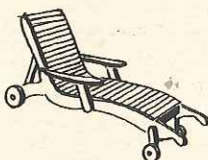

No. 78 Garden Chaise . . . 35c



No. 75 Terrace Table . . . 35c

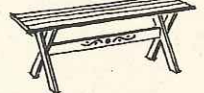

No. 57 Peasant Bench . . . 25c



No. 39 Lawn Settee . . . 35c



No. 94 California Sun Set . . . \$1.00



No. 76 Terrace Chair . . . 25c



No. 22 Picnic Table . . . 25c

BUILDINGS

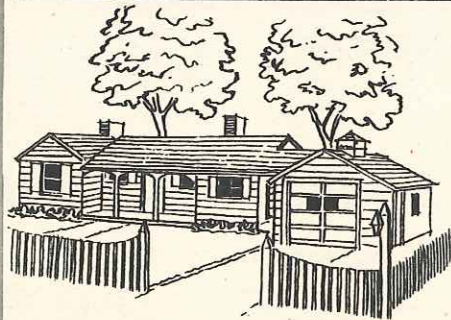

No. 910 2 Bedroom House . . . \$5.00

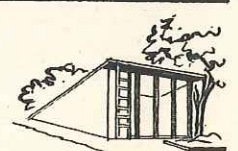

No. 100 Child's Playhouse . . . 60c



No. 14 Poultry House . . . 60c

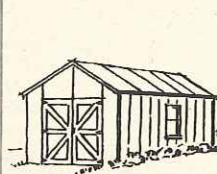

No. 101 Garage . . . 50c

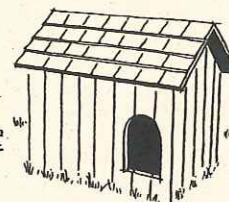

No. 28 Dog House . . . 35c

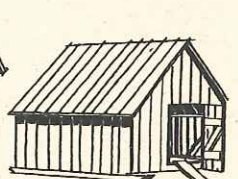

No. 13 Hog House . . . 50c

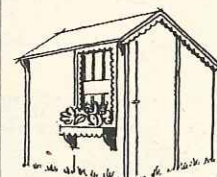

No. 51 Tool and Garden House . . . 50c

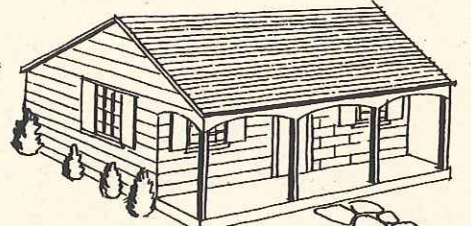

No. 91 Country Cottage . . . \$2.00

EVERY HOME NEEDS



No. 81 Lawn Ornaments . . . 25c

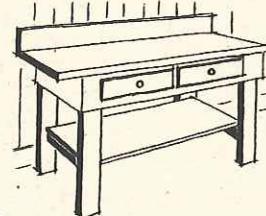

No. 15 Handy Workbench . . . 25c

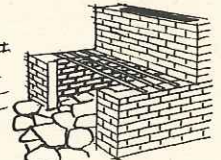

No. 73 Outdoor Fireplace . . . 25c

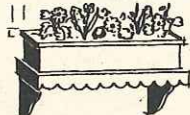

No. 19 Window Box . . . 25c

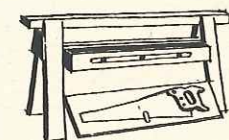

No. 44 Sawhorse Tool Chest . . . 35c

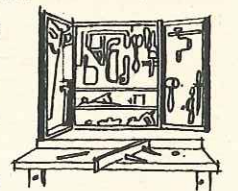

No. 71 Tool Chest . . . 25c

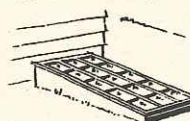

No. 12 Garden Hotbed . . . 25c

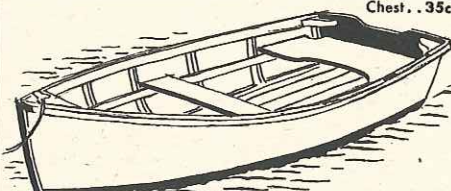

No. 85 Utility Boat . . . \$1.00

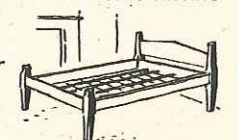

No. 68 Single or Double Bed . . . 25c

GIFTS AND TOYS



No. 54 Hobby Horse..20c

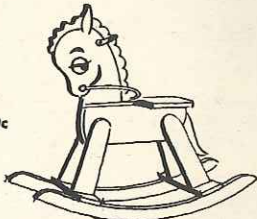

No. 53 Pony Ride Rocker..35c

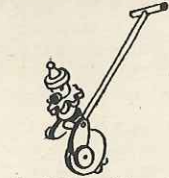

No. 47 Wheel Toy..25c

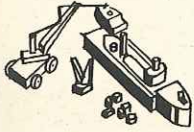

No. 60 Derrick-Ship..25c

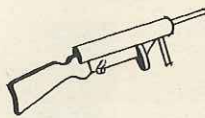

No. 58 Tommy Gun..20c

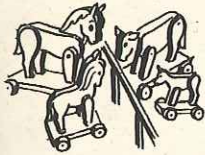

No. 83 Animals..25c



No. 48 Complete Circus..25c

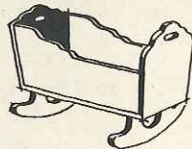

No. 64 Colonial Cradle..25c

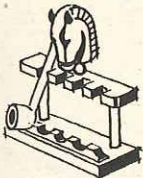

No. 49 Pipe Rack..25c

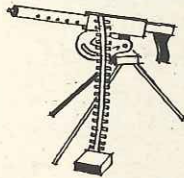

No. 62 Machine Gun..25c



No. 79 Animals..25c



No. 65 Toy Chest..25c



No. 59 Doll Carriage..35c

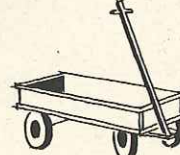

No. 40 Express Wagon..35c



No. 46 Plant Holder..25c

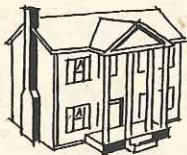

No. 33 Doll House..50c



No. 61 Doll Carriage..25c



No. 67 Ferry Boat..25c

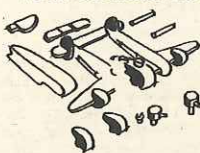

No. 50 Airplane Group..25c

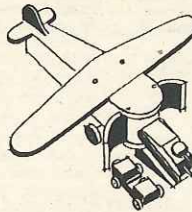

No. 70 Cargo Glider..25c

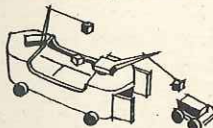

No. 72 Amphibious Freighter..25c

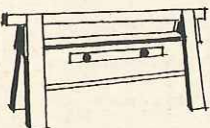

No. 45 Shoeshine Box..25c

CHILDREN'S EQUIPMENT

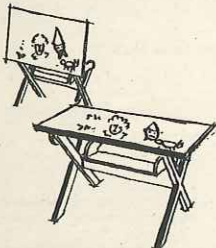

No. 117 Playtable..25c



No. 20 Sandbox..25c



No. 34 Clothesree..25c

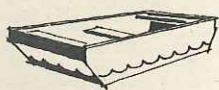

No. 77 Boat Sandbox..35c

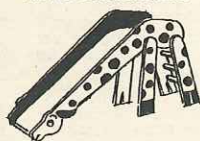

No. 63 Child's Slide..50c

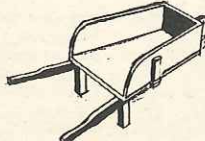

No. 66 Wheelbarrow..25c

INTERIOR



No. 38 Corner Cabinet..50c

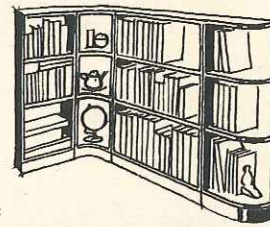

No. 42 Modern Bookcase..50c

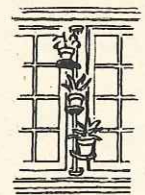

No. 7 Flower Pot Holder..15c

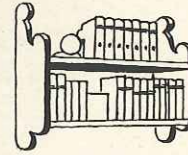

No. 21 Bookshelf..15c



No. 30 Window Valance..25c

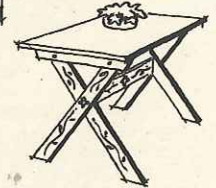

No. 17 Peasant Table..25c



No. 52 Coffee Table..25c

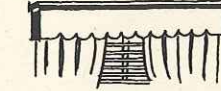

No. 27 Window Valance..25c

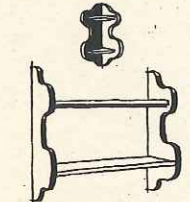

No. 35 Whatnot Shelf..20c

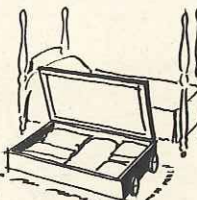

No. 37 Storage Chest..25c



No. 31 Whatnot Shelf..20c



No. 26 Wall Table..25c

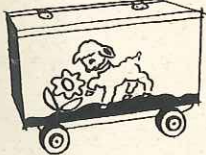

No. 49 Pipe Rack..25c



No. 59 Doll Carriage..35c

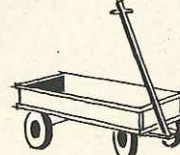

No. 40 Express Wagon..35c



No. 46 Plant Holder..25c

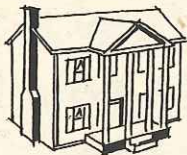

No. 33 Doll House..50c



No. 61 Doll Carriage..25c



No. 67 Ferry Boat..25c

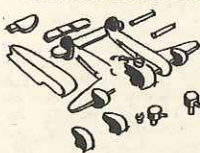

No. 50 Airplane Group..25c

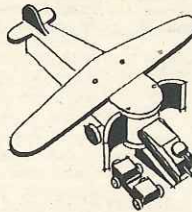

No. 70 Cargo Glider..25c

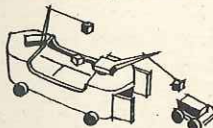

No. 72 Amphibious Freighter..25c

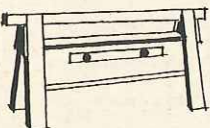

No. 45 Shoeshine Box..25c

No. 25 Magazine Rack..25c

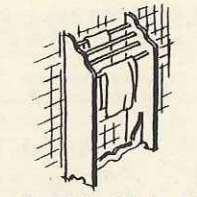

No. 29 Towel Rack..20c

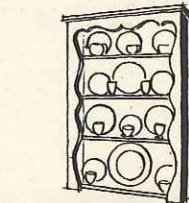

No. 36 Dutch Wall Cabinet..25c

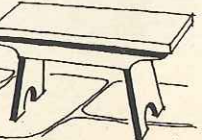

No. 23 Fireside Bench..25c

No. 29 Towel Rack..20c

No. 18 Bookcase..25c

No. 24 Wall Shelf..25c

KITCHEN EQUIPMENT

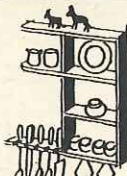

No. 5 Kitchen Shelf..25c

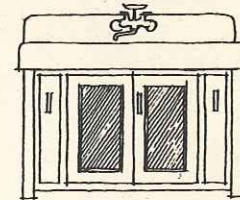

No. 41 Undersink Enclosure..50c

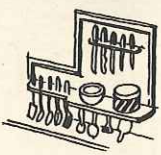

No. 8 Knife Rack..25c

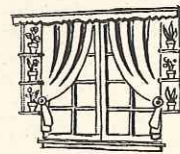

No. 1 Window Valance..25c

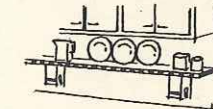

No. 4 Narrow Shelf..25c

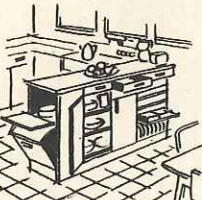

No. 80 Service counter..60c

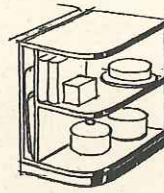

No. 3 Kitchen Unit..50c

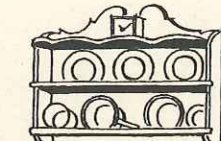

No. 6 All Purpose Shelf..25c

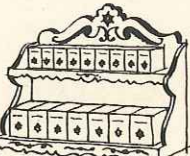

No. 2 Peasant Shelf..25c

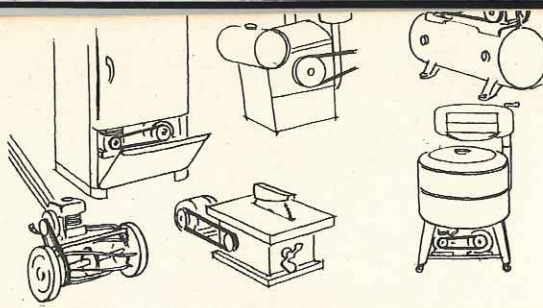

Replace worn out V-Belts now!

Faulty, worn out V-belts are costly! Power is wasted because of the increased slipping . . . they slow down production . . . they're hazardous and unsafe, helping to cause accidents. Replace them today with CRAFTSMAN V-Belts—the long wearing, true running V-belts. CRAFTSMAN V-Belts are built to resist slipping and stretching. They rarely need replacement. Your machines will perform at top efficiency . . . CRAFTSMAN V-Belts transmit maximum power with minimum friction loss.

Our complete line of CRAFTSMAN V-Belts afford you the correct size V-belt for use on power tools, electric refrigerators, washing machines, water pumps, air compressors, power lawn mowers, floor sanders, lathes, farm machinery, garage and shop power tools.

HOW TO MEASURE
Be sure to measure around the outside edge of pulleys (not in the groove) to get the correct length of V-belt wanted.

As low as
49c
Each

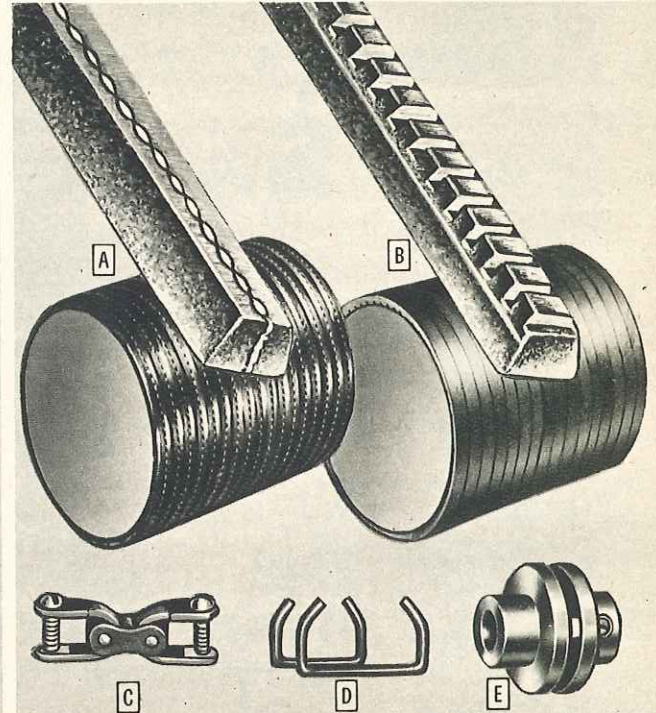

Get more pulling power, less frictional loss with CRAFTSMAN super-tough, pliable V-Belts

CRAFTSMAN V-Belts are expertly made from the finest materials available. Each belt has double-layer, closely woven cotton jacket around pliable, heat resistant rubber. Reinforcing cords pre-treated in liquid rubber.

1/2-inch V-Belts
CRAFTSMAN quality. Correct size for most applications with V-pulleys, 2-inch diameter or larger. Be sure to see "How to Measure" above.

Catalog no.	Length	Shpg. wt.	Each
9 T 1622	22 in.	4 oz.	51c
9 T 1624	24 in.	4 oz.	52c
9 T 1625	25 in.	4 oz.	53c
9 T 1626	26 in.	4 oz.	54c
9 T 1628	28 in.	4 oz.	55c
9 T 1629	29 in.	4 oz.	56c
9 T 1630	30 in.	5 oz.	57c
9 T 1631	31 in.	5 oz.	58c
9 T 1632	32 in.	5 oz.	60c
9 T 1633	33 in.	5 oz.	62c
9 T 1634	34 in.	6 oz.	63c
9 T 1635	35 in.	6 oz.	64c
9 T 1636	36 in.	6 oz.	65c
9 T 1637	37 in.	6 oz.	67c
9 T 1638	38 in.	7 oz.	69c
9 T 1639	39 in.	7 oz.	71c
9 T 1640	40 in.	7 oz.	73c
9 T 1641	41 in.	7 oz.	75c
9 T 1642	42 in.	7 oz.	77c
9 T 1643	43 in.	7 oz.	79c
9 T 1644	44 in.	7 oz.	81c
9 T 1645	45 in.	7 oz.	82c
9 T 1646	46 in.	7 oz.	83c
9 T 1647	47 in.	7 oz.	84c
9 T 1648	48 in.	7 oz.	85c
9 T 1650	50 in.	7 oz.	88c
9 T 1651	51 in.	7 oz.	90c
9 T 1652	52 in.	7 oz.	92c
9 T 1654	54 in.	7 oz.	94c
9 T 1656	56 in.	8 oz.	97c
9 T 1658	58 in.	8 oz.	\$1.00
9 T 1660	60 in.	8 oz.	1.03
9 T 1662	62 in.	8 oz.	1.06
9 T 1664	64 in.	8 oz.	1.09
9 T 1666	66 in.	9 oz.	1.12
9 T 1684	84 in.	10 oz.	1.39
9 T 16100	100 in.	11 oz.	1.59

3/8-inch V-Belts
CRAFTSMAN quality. Correct size for use on drives over small diameter pulleys. Be sure to see "How to Measure" explained above.

Cat. no.	Length	Shpg. wt.	Each
9 T 1520	20 in.	4 oz.	49c
9 T 1522	22 in.	4 oz.	50c
9 T 1524	24 in.	4 oz.	52c
9 T 1526	26 in.	4 oz.	53c
9 T 1528	28 in.	4 oz.	54c
9 T 1530	30 in.	4 oz.	55c
9 T 1532	32 in.	4 oz.	57c
9 T 1534	34 in.	4 oz.	60c
9 T 1536	36 in.	4 oz.	63c
9 T 1538	38 in.	4 oz.	65c

5/8-inch V-Belts
CRAFTSMAN quality. For heavier drives over minimum pulley diameter of 3 inches. Extra heavy duty. Machines perform at top efficiency.

Cat. no.	Length	Shpg. wt.	Each
9 T 1734	34 in.	5 oz.	79c
9 T 1736	36 in.	5 oz.	83c
9 T 1738	38 in.	5 oz.	87c
9 T 1740	40 in.	6 oz.	92c
9 T 1742	42 in.	6 oz.	98c
9 T 1743	43 in.	8 oz.	\$1.02
9 T 1744	44 in.	8 oz.	1.04
9 T 1746	46 in.	10 oz.	1.06
9 T 1750	50 in.	10 oz.	1.19
9 T 1752	52 in.	11 oz.	1.25
9 T 1754	54 in.	11 oz.	1.29
9 T 1771	71 in.	14 oz.	1.65
9 T 1778	78 in.	15 oz.	1.85
9 T 1788	88 in.	1 lb. 2 oz.	2.05
9 T 1793	93 in.	1 lb. 3 oz.	2.09
9 T 17100	100 in.	1 lb. 4 oz.	2.30
9 T 17108	108 in.	1 lb. 5 oz.	2.50

Leather V-Belting

A Use this fractional horsepower plain leather V-belting for rapid replacements on your power tools, and other machines. No need to remove machinery to replace belt. Made of two thick plies of tough, rugged oak-tanned leather cemented together and then sewn down the center. Steel wire hook is included with every length.

9 T 2777—Please be sure to state width and length wanted.
3/4-inch width. Shipping weight per foot 3 ounces. . . . Per inch 2c
1/2-inch width. Shipping weight per foot 4 ounces. . . . Per inch 3c
5/8-inch width. Shipping weight per foot 5 ounces. . . . Per inch 3 1/2c

V-belt Couplers

C Here's the ideal way to shorten old leather V-belts or to couple together new ones. Coupler consists of roller chain link between two bails. Will not cause additional vibration. So simple and easy to install. Use for 3/4-inch, 1/2-inch or 5/8-inch V-belting.
9 T 2842—Shpg. wt. 1 oz. . . 29c

Wire V-Belt Hooks

D Simple and easy to use. Just punch holes into belt, insert hook and clinch. That's all there is to connecting leather V-belt sections when you use these convenient wire belt hooks. Made of tough steel music wire. Makes a safe dependable connection. Shpg. wt. of six 1 oz.
9 T 2847—State size wanted.
Small size. For 3/8 or 1/2-inch belt. . . . Each 1c
Large size. For 1/2 or 5/8-inch belt. . . . Each 1c

"Notched" V-Belting

B Notched V-belting made of tough, strong oak-tanned leather. Fine grade of leather and expert tanning make this belting extremely flexible. Notches are cut crosswise in under surface. Gives belt greater flexing ability and more positive, non-slip-grip contact with the pulleys. Ideal for fractional horsepower drives. Heavy steel wire hook is included with every length. Be certain to measure carefully the length around the outside of your pulleys (not in grooves) to determine the length needed.

9 T 2778—Please be sure to state length and width wanted.
1/2-inch width. Shipping weight per foot 3 ounces. . . . Per inch 3c
5/8-inch width. Shipping weight per foot 4 ounces. . . . Per inch 4 1/2c
9 T 2779—3/8-inch oak-tanned leather V-belting. Similar to above but not notched. Shipping weight per foot 3 ounces. . . . Per inch 2c

Flexible Coupling

E The ideal coupling to use where motor is connected directly to a machine. This sturdy flexible coupling connects motor and machine shafts, and allows for slight misalignment between them. It helps prevent wear on the bearings which might result if a rigid coupling were used. Die cast metal construction. Accurately machined and well finished. Available for use with 1/2, 3/8 or 5/8-inch shafts. Please state bore size wanted when ordering. Shipping weight 12 ounces.
9 T 2840. Each 65c

For Easy Terms see inside back cover

Pulleys for Power Tools, Motors, etc.

CRAFTSMAN Pulleys and V-Belts on your power tools, pumps, etc. save you time and money! Here's the reason why. V-pulleys and belts are designed to transmit maximum power with a minimum friction loss and slippage. CRAFTSMAN V-Pulleys give you this, because the grooves are accurately turned to provide a positive non-slip grip for belts. Reduced belt slippage means less power loss . . . therefore quieter operation, less vibration and faster pickup. You accomplish your job faster, more efficiently.

CRAFTSMAN Pulleys and V-Belts are the most economical means of power transmission for power tools. Use CRAFTSMAN single or double groove V-pulleys on bench saws, builder's saw, band saw, etc. CRAFTSMAN cone type V-pulleys give multiple speeds when used in pairs on jig saws, lathes, etc.

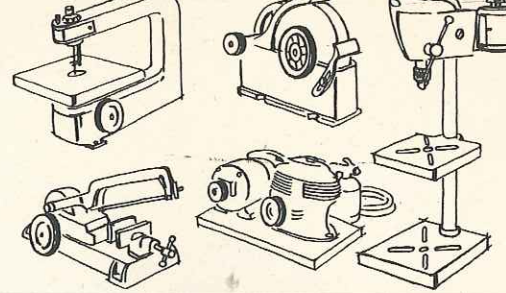

REMEMBER — when ordering CRAFTSMAN V-Pulleys be sure to state the exact size of bore wanted.



Gives a snug, non-slip grip.

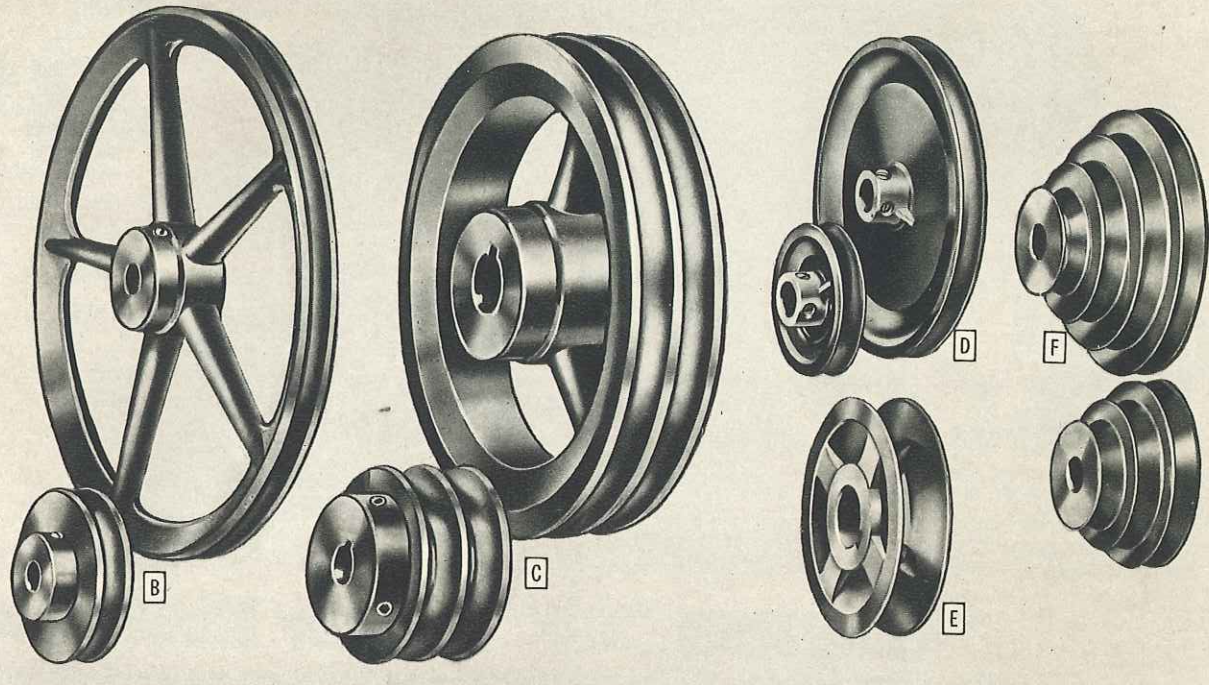
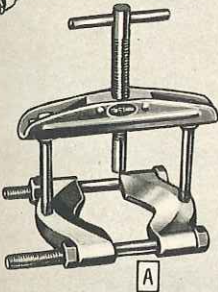

Scientifically designed for greater efficiency . . .

CRAFTSMAN V-Pulleys are available for most power tools

Pulley Remover

A CRAFTSMAN professional quality. An excellent sheave and pulley remover for removing small V-drive pulleys when frozen fast on electric motors or other power tool shafts, and for removing single or multiple drive sheaves.

Fits single or multiple groove pulleys, gears, bearings, etc. Eliminates the need for pulling on outer flange. Clamps down in V-groove of sheave or pulley and distributes the pulling strain evenly around a great part of the circumference. Gives a positive non-slip grip. Capacity 1 1/4 to 4 1/2 inches. Strong steel construction.

One of the handiest tools for the home workshop or for the man who does set-up and mechanical repair work. Solves many service and maintenance problems.

9 T 4696—Shpg. wt. 4 lbs. \$2.49

Table of Pulley Speeds

Use this table to determine the speed of your machine with varying sizes of motor and machine pulleys. Figures given are for use with belt at proper tension and a motor speed of 1750 R.P.M.

Diam. of Driving or Motor Pulley	Diameter in inches of Machine or Driven Pulley				
	1 1/2	2	2 1/2	3	4
1 1/2 inches . . .	1725	1290	1030	860	645
2 inches	2300	1725	1380	1150	860
2 1/2 inches	2890	2160	1725	1440	1080
3 inches	3450	2590	2070	1725	1290
4 inches	4600	3450	2760	2300	1725
5 inches	5750	4310	3450	2870	2160
6 inches	7460	5600	4490	3740	2800

EXAMPLE—the machine has a 2-in. pulley and should run 3450 or 3500 R.P.M. What size pulley should be used with a 1750 R.P.M. motor? From the above table, follow down the vertical 2-in. column to the speed of 3450, then to the left in column headed "Diameter of Driving or Motor Pulley." The answer is a 4-inch diameter pulley is required.

CRAFTSMAN offers a line of long-wearing, high quality V-pulleys in sizes and types for most every requirement. CRAFTSMAN pulleys are scientifically designed for greatest working efficiency and are carefully and accurately manufactured to give you top working performance from your machinery or power tools. All the belt grooves are painstakingly machined to run perfectly true. All bores are reamed to exact size. Please remember that diameters given in the table listings below refer to outer edge of pulleys, not to bottom of the groove. Before ordering, carefully check diameter and bore size wanted.

CRAFTSMAN single-groove V-Pulleys

B Made of heavy cast iron. Heavy duty for production work in the shop, household or on the farm. Use to replace single groove V-pulleys on any type electric motor or gas engine. Positive grip grooves are expertly machined and bores are accurately reamed. CRAFTSMAN single groove V-Pulleys have slotted-head, hardened, set screw. Standard keyways in 3/8-inch or larger bores. The grooves fit V-belts 3/8-inch (O section) or 1/2-inch (A section) wide. Order by catalog number and please remember to state clearly the size of bore which you require.

Cat. no.	Diam.	Bore, inch	Shpg. wt.	Each
9 T 2880 . . .	1 1/2 in.	1/2	9 oz.	49c
9 T 2881 . . .	2 in.	1/2, 5/8	11 oz.	59c
9 T 2882 . . .	2 1/2 in.	1/2, 5/8, 3/4	15 oz.	69c
9 T 2883 . . .	3 in.	1/2, 5/8, 3/4	1 lb. 6 oz.	80c
9 T 2884 . . .	4 in.	1/2, 5/8, 3/4	2 lbs. 3 oz.	98c
9 T 2885 . . .	5 in.	1/2, 5/8, 3/4	2 lbs. 7 oz.	\$1.09
9 T 2886 . . .	6 1/2 in.	1/2, 5/8, 3/4, 1	3 lbs.	1.29
9 T 2808 . . .	8 in.	1/2, 5/8, 3/4, 1	3 lbs. 15 oz.	1.75
9 T 2810 . . .	10 in.	1/2, 5/8, 3/4, 1	4 lbs. 7 oz.	2.09
9 T 2812 . . .	12 in.	1/2, 5/8, 3/4, 1	5 lbs. 11 oz.	2.65
9 T 2814 . . .	15 in.	3/4, 1	10 lbs.	5.30

CRAFTSMAN single groove V-Pulleys

D Made of tough alloy metal die cast. Strong flanges and hubs; machined grooves and reamed bores. Two-slotted head, hardened set screws insure positive locking of pulley on shaft. For 3/8-(O section) or 1/2-(A section) inch wide V-belts, except 9T2800, which is for use with 3/8-(O section) inch belt only. State bore size.

Cat. no.	Diam.	Bore, inch	Shpg. wt.	Each
9 T 2800 . . .	1 1/2 in.	1/2	3 oz.	39c
9 T 2801 . . .	2 in.	1/2, 5/8	5 oz.	42c
9 T 2802 . . .	2 1/2 in.	1/2, 5/8, 3/4	6 oz.	53c
9 T 2803 . . .	3 in.	1/2, 5/8, 3/4	7 oz.	57c
9 T 2804 . . .	4 in.	1/2, 5/8, 3/4	10 oz.	63c
9 T 2805 . . .	5 in.	1/2, 5/8, 3/4	15 oz.	75c
9 T 2806 . . .	6 1/2 in.	1/2, 5/8, 3/4	1 lb. 6 oz.	\$1.07

CRAFTSMAN hubless V-Pulleys

E Permit use of pulleys side by side for multiple drives. Sturdily built of tough alloy die cast metal. Machined grooves and reamed bores. Two slotted head, hardened set screws lock pulley on shaft. For 3/8-(O section) or 1/2-(A section) inch wide V-belts. State bore size.

Cat. no.	Diam.	Bore	Shpg. wt.	Each
9 T 29012 inches	1/2, 3/8 inch	6 ounces	42c
9 T 2902 . . .	2 1/2 inches	1/2, 5/8, 3/4 inch	9 ounces	49c
9 T 2903 . . .	3 inches	1/2, 5/8, 3/4 inch	11 ounces	50c

CRAFTSMAN two-groove V-Pulleys

C Made of heavy cast iron. For heavy production work. Use on electric motors or gas engines on industrial, farm, workshop or household machines. Standard keyways. Two hardened, hollow head set screws. With wrench. For V-belts 1/2 (A section) or 3/4 (B section) inch wide. State bore size.

Cat. no.	Diam.	Bore, inch	Shpg. wt.	Each
9 T 2940 . . .	3 in.	5/8, 3/4, 1	2 lbs. 11 oz.	\$2.95
9 T 2941 . . .	4 in.	5/8, 3/4, 1	4 lbs. 1 oz.	3.65
9 T 2942 . . .	5 in.	5/8, 3/4, 1, 1 1/16	4 lbs. 9 oz.	3.95
9 T 2943 . . .	6 in.	3/4, 1, 1 1/16	6 lbs. 6 oz.	4.79
9 T 2944 . . .	8 in.	1, 1 1/16	9 lbs. 11 oz.	5.95
9 T 2945 . . .	10 in.	1, 1 1/16	11 lbs. 8 oz.	6.95
9 T 2946 . . .	12 in.	1, 1 1/16	13 lbs. 15 oz.	8.25

CRAFTSMAN Cone Type V-Pulleys

F Use in pairs for variable speed applications. Made of tough alloy die cast metal. Three and four step. Two hardened, slotted head set screws lock pulley on shaft. For 3/8-(O section) or 1/2-(A section) inch wide V-belts. Have 1/2, 3/8 or 3/4-inch bore. State bore size wanted.

Cat. no.	Size	Diam., step, in.	Shpg. wt.	Each
9 T 2788 . . .	3 3/8 in.	3 3/8, 2 5/8, 2	1 lb.	95c
9 T 2792 . . .	4 in.	4, 3 3/8, 2 5/8, 2	1 lb. 10 oz.	\$1.15
9 T 2793 . . .	5 in.	5, 4, 3, 2	1 lb. 14 oz.	1.30

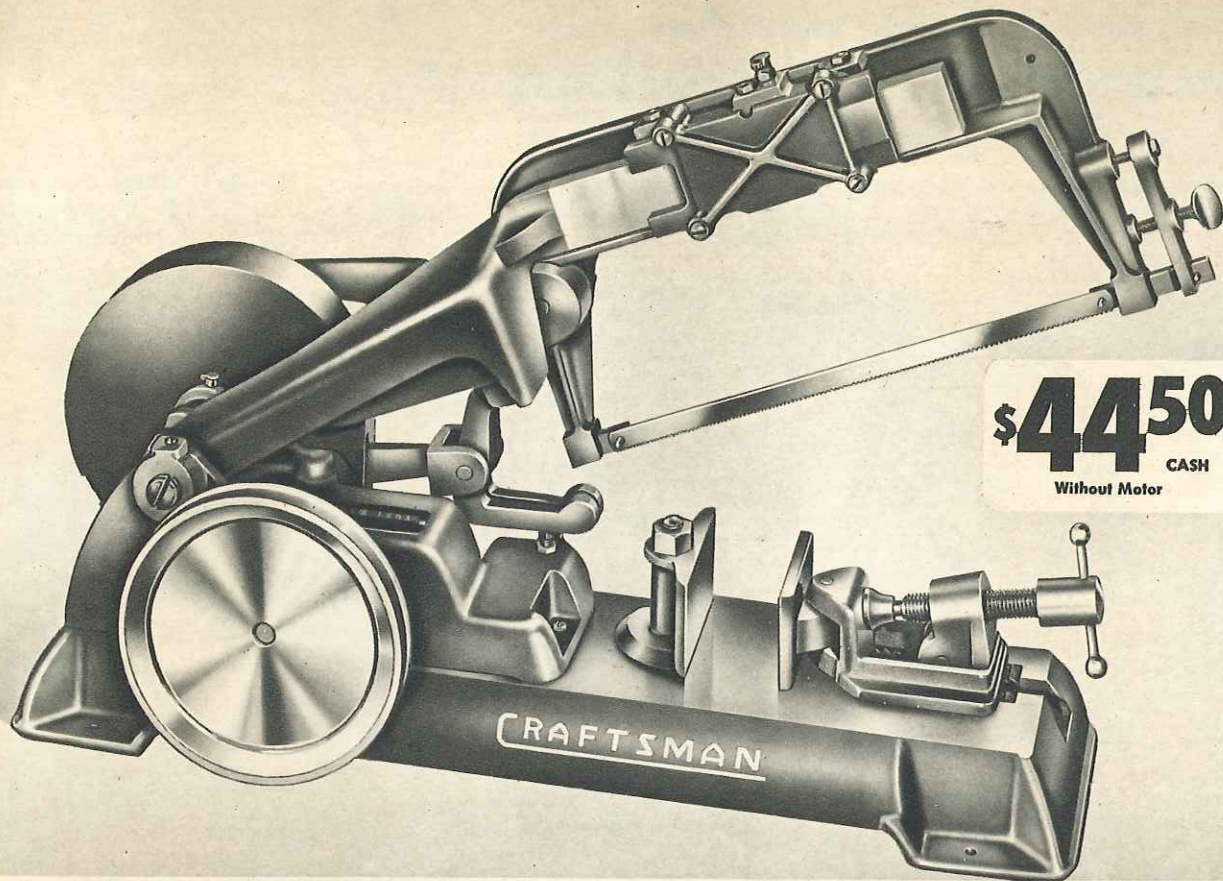

\$44.50 CASH
Without Motor

\$4.50 DOWN . .
ON TERMS

CRAFTSMAN "80" Power Hack Saw

Heavy duty model . . . semi-automatic . . . cuts accurately unattended

Save time . . . save labor . . . reduce operating costs . . . speed up production . . . when you use this CRAFTSMAN "80" Power Hack Saw. Ideal for plumbers, electricians, garages and other metal workers.

Extra large capacity. This power hack saw makes cuts on material up to 4x4 inches at 90° . . . makes angles cuts 90 to 45°. It will cut iron, steel, brass, aluminum, etc; quickly and accurately. It has a 5-inch stroke; 60 strokes per minute, at 400 R.P.M.

Fully automatic. The CRAFTSMAN "80" makes cuts alone while you work at other jobs. Just place material in quick-locking vise, adjust for correct angle and turn on the power. That's all there is to it. Draw

cut action lifts blade from the work on the return stroke. Gives a clean, accurate cut . . . adds many hours of service to the life of the blade.

Rugged construction. Shafts run on extra large bronze oilite bearings. Slide and arm made of special wear-resistant cast semi-steel. Arm pivot is cone type; adjustable construction. Oiled through spring oilers.

SPECIFICATIONS:

- Capacity, maximum 4x4 inches
- Angle cuts 90 to 45 degrees
- Bearings Bronze, oilite
- Length of blade 12 inches
- Width of blade 1/2 inch

- Machine pulley (included) 6 1/2-inch
 - Motor pulley (not included) 1 1/2-inch
 - Motor recommended, min. 1/2 H.P. 1750 R.P.M.
 - Base size 6x24 inches
 - Mounting dimensions 5 1/4 x 19 x 7/8 inches
 - Over-all dimensions: height 10 inches; width 9 inches; length (extended) 29 (not extended) 26 in.
- 99 TM 2294—Without motor. Shpg. wts. 60 lbs. \$44.50
- 99 TM 2285—With 1/2 H.P. 1750 R.P.M. split phase ball bearing 110-120 volt A.C. motor. Shpg wt. 90 lbs. \$63.00
- 99 T 6582—CRAFTSMAN—12-inch power hack saw blades. Special tool steel. 14 or 18 teeth per inch. *State choice wanted* Shpg. wt. 3 oz. 2 for 98c

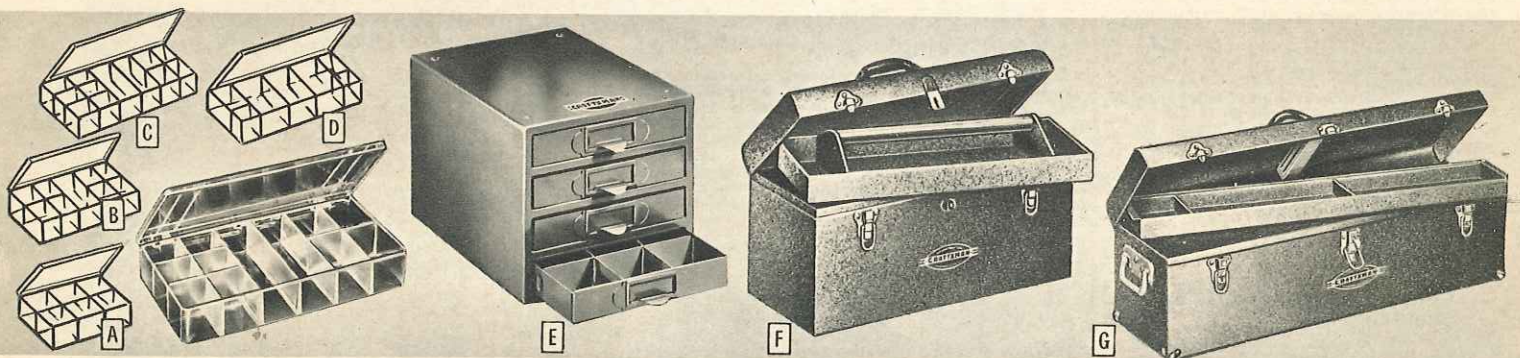

Transparent Plastic Utility Boxes

Don't mislay those small machine, radio or electrical parts! Store them safely in one of these transparent plastic boxes. The ideal container for holding hobby shop items, fishing tackle—flies, lures, hooks, etc.; tacks . . . screws, nails, washers, etc. They're so convenient and handy . . . a real time saver. Exceptionally lightweight. Thick transparent plastic walls keep items separated, yet easy to find without opening the box. Dirt and dust-free! Have snug covers with smooth working hinges. Available in various sizes with various size compartments. See small views above for the types available.

Catalog No.	Compartment	Length	Width	Depth	Shpg. wt.	Each
A . . . 9T6525	...Six . . .	4 1/2 in.	2 3/4 in.	1 in.	8 oz.	69c
B . . . 9T6523	...Nine . . .	7 in.	3 1/2 in.	1 1/4 in.	9 oz.	89c
C . . . 9T6530	...Twelve . .	8 1/2 in.	4 1/2 in.	1 1/4 in.	11 oz.	\$1.19
D . . . 9T6526	...Seven . . .	8 1/2 in.	4 1/2 in.	1 1/4 in.	11 oz.	1.19

Tool Cabinet

E Handy four-drawer tool cabinet. Ideal for storing small tools and parts. Drawer fronts have useful index card holders and pulls. Made of 24-gauge sheet steel, electrically welded. Dimensions: length 10 in.; width 7 1/2 in.; height 8 1/2 in. Each of four drawers, 7 1/2 x 10 x 1 1/4 in., have 12 partitions that are adjustable and removable. Smooth machinery gray finish. Shpg. wt. 8 lbs.

9 T 6531 \$5.25

Mechanics' Tool Box

F CRAFTSMAN quality. Size of tool box: 20x8 1/2 x 9 3/8 inches. Holds 75 to 100 sockets and socket wrench parts. Has sufficient room for all the tools a mechanic will need for the job. Made of 22-gauge steel, electrically welded for added strength. All edges are rounded for protection. Equipped with full length, easy-action piano-type hinge. The large, partitioned, lift out "tote" tray is excellent for keeping small tools in order. Has two lever-type latches and a hasp with padlock eye. Cover has heavy aluminum handle for easy carrying. Machinery gray rust-resisting finish. Shpg. wt. 11 lbs.

99 T 06512 \$4.95

Carpenters' Tool Box

G CRAFTSMAN. Size 30x8 1/2 x 9 inches. Large enough to hold a full set of carpenter's tools. Splendid for mechanics and plumbers who use long tools. Made of 22-gauge steel with 20-gauge steel end plates; electrically welded. Edges rounded for safety. Divided tray for storing small tools. Equipped with wood saw clips in both top and bottom to hold four hand saws. Metal handles on both ends and on top. Full-length piano-type hinge. High quality lock and keys. Extra strong loop-type side hasps. Rust-resisting machinery gray finish. Shpg. wt. 20 lbs.

99 T 06517 \$7.95

All Power Tools and Accessories can be bought on

SEARS EASY PAYMENT PLAN

Only 10% down EASY TERMS AS LOW AS

\$5

A MONTH

You, like thousands of our customers, will find our Easy Payment Plan a convenient, economical way to get the power tools and accessories you want now . . . to use and enjoy while paying for them over the months ahead.

You don't have to have all ready cash, nor is it necessary to disturb your savings to buy CRAFTSMAN power tools and accessories . . . the better quality merchandise . . . from this 1948 Power Tool catalog because everything we sell regardless of price is available on Easy Terms. A small down payment with your purchase and the balance in convenient monthly payments brings you the things you need when you need them.

Buy at Sears to save . . . use Sears Easy Payment Plan to buy . . . it's easy to open an account.



How to purchase on Sears Easy Terms

If you are buying through one of our retail stores or retail offices, our salespeople will handle your purchase quickly and courteously. If you wish to order direct from our mail order house, list the tools you wish to order on an Order Blank. Total the cash prices. *Be sure your order is for \$10 or more.* Fill in the answers to the Easy Payment questions and sign. Enclose a check or money order for the required down payment and mail your order to Sears nearest mail order house.



For amount payable monthly

Consult the Payment Table at the right. The monthly payment is only \$5 for an unpaid balance up to \$55. Many of your tool and shop needs can be filled on one Easy Payment order without increasing the amount you pay each month.



Additional purchases

Once you have an open account on our books you'll find it a real convenience. When you need new tools, accessories, or supplies, you may add them to your account—in most cases with no down payment and no increase in your monthly payments. *You need not make any Down Payment with your "add-on" orders.* Just give your account number and say, "Add it to my account."

SEARS GUARANTEE

- TO DELIVER ALL MERCHANDISE SAFELY
- TO SATISFY YOU PERFECTLY

We guarantee that every article in this catalog is honestly described and illustrated.

We guarantee that any article purchased from us will give you the service you have a right to expect.

If for any reason whatever you are not satisfied with any article purchased from us, we want you to return it to us at our expense.

We will then exchange it for exactly what you want, or will return your money.

SEARS, ROEBUCK AND CO.

MONTHLY PAYMENT TABLE

If unpaid balance amounts to	We shall add for Easy Payments	Amount payable monthly is
Up to \$16.00	\$1.00	\$5.00
\$16.01 to 18.00	1.25	
18.01 to 20.00	1.50	
20.01 to 22.00	1.75	
22.01 to 24.00	2.00	
24.01 to 26.00	2.25	
26.01 to 28.00	2.50	
28.01 to 30.00	2.75	
30.01 to 33.00	3.00	
33.01 to 36.00	3.30	
36.01 to 40.00	3.60	
40.01 to 45.00	4.00	
45.01 to 50.00	4.50	
50.01 to 55.00	5.00	
55.01 to 60.00	5.50	
60.01 to 65.00	6.00	
65.01 to 70.00	6.50	7.00
70.01 to 75.00	7.00	
75.01 to 80.00	7.50	8.00
80.01 to 85.00	8.00	
85.01 to 90.00	8.50	
90.01 to 95.00	9.00	9.00
95.01 to 100.00	9.50	
100.01 to 110.00	10.00	10.00
110.01 to 120.00	11.00	
120.01 to 130.00	12.00	10.50
130.01 to 140.00	13.00	
140.01 to 150.00	13.50	11.00
150.01 to 160.00	14.00	
160.01 to 170.00	14.50	12.00
170.01 to 180.00	15.50	
180.01 to 190.00	16.50	13.00
190.01 to 200.00	17.50	
200.01 to 210.00	18.00	13.50
210.01 to 220.00	19.00	
220.01 to 230.00	20.00	14.00
230.01 to 240.00	21.00	
240.01 to 250.00	22.00	14.50
250.01 to 260.00	23.00	
260.01 to 270.00	24.00	15.50
270.01 to 280.00	24.50	
280.01 to 290.00	25.00	16.00
290.01 to 300.00	25.00	
290.01 to 300.00	26.00	16.50
290.01 to 300.00	26.00	17.00
290.01 to 300.00	26.00	17.50
290.01 to 300.00	26.00	18.50

Write for terms over \$300.00

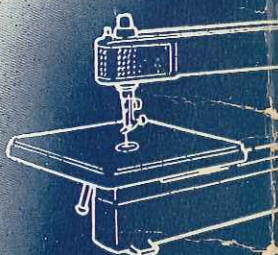
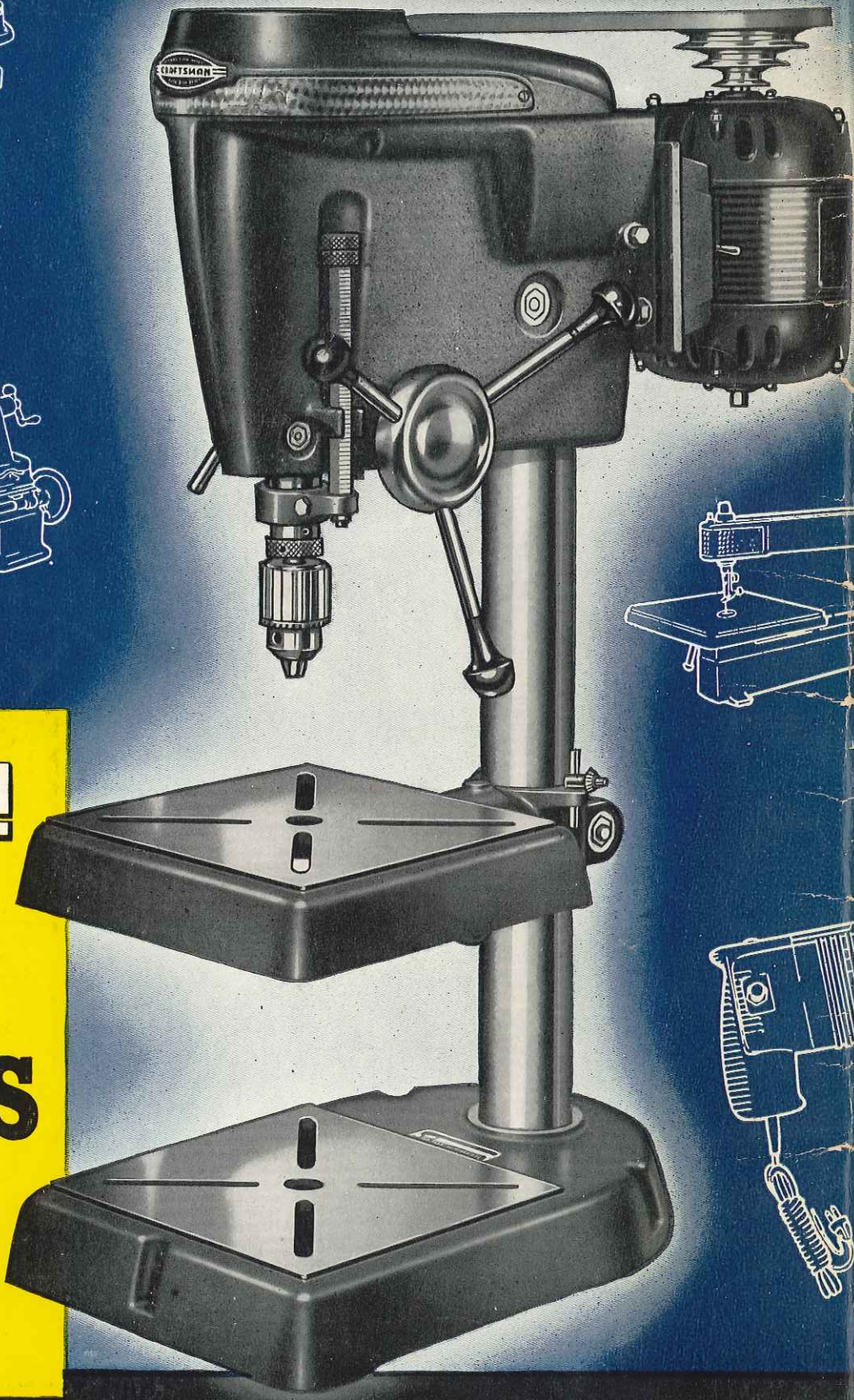
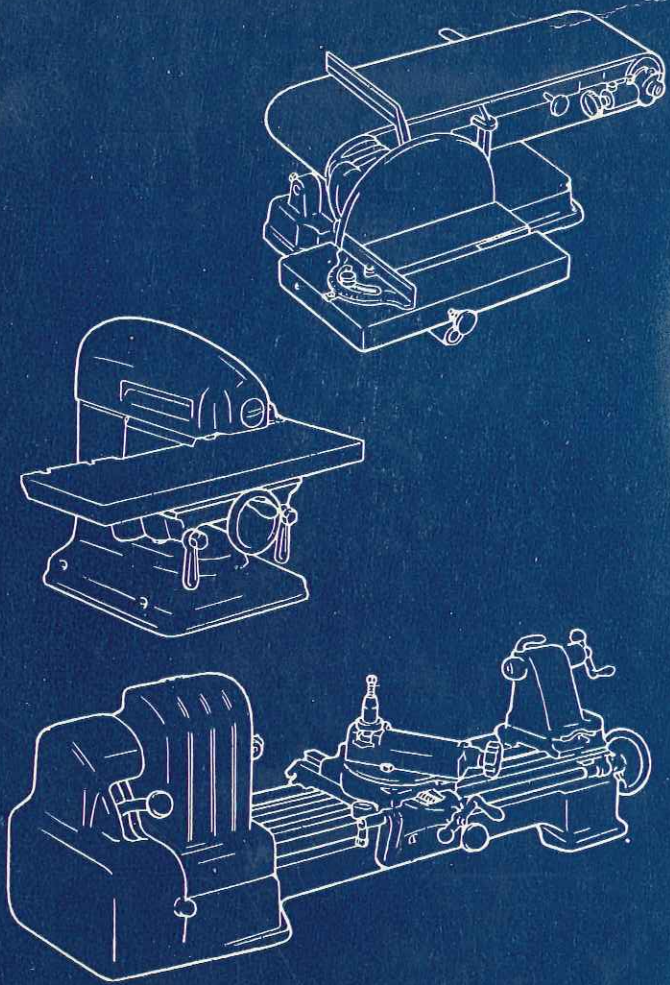

CRAFTSMAN
REG. U. S. PAT. OFF.

DRILL PRESSES

For a complete description
of **CRAFTSMAN** Drill Presses
REG. U. S. PAT. OFF.
and accessories, turn to
pages 28 and 29

SEARS ROEBUCK and CO.
Satisfaction Guaranteed or Your Money Back . . .