



CRAFTSMAN

**TYPICAL APPLICATIONS FOR
CRAFTSMAN POWER TOOL BENCHES
AND PEDESTAL STANDS**



SEARS, ROEBUCK AND CO. — U.S.A.
IN CANADA SIMPSONS — SEARS LIMITED

CRAFTSMAN POWER TOOL BENCHES

CATALOG NUMBERS 10525 AND 1071

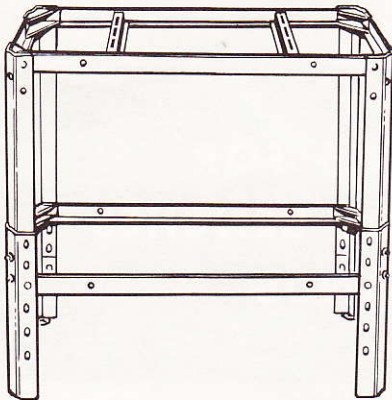

CATALOG NO. 10525

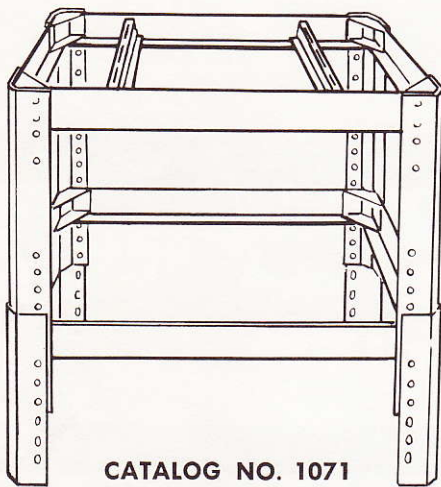

CATALOG NO. 1071

A Craftsman Power Tool Bench is the perfect companion to your Craftsman Power Tool. Two basic configurations (one rectangular and the other square) provide a wide variety of power tool mounting combinations.

Each bench is constructed of heavy-duty steel members bolted together to form a rigid structure.

The rectangular bench, No. 10525, (16-1/4 x 30 inches) can be adjusted in height from 23-1/4 to 29-5/8 inches.

The square bench, No. 1071, (26 x 26 inches) can be adjusted in height from 22-1/8 to 31-11/16 inches.

ADDITIONAL PARTS NECESSARY FOR MOUNTING OF SOME POWER TOOLS

(See Charts on pages 3 and 5)

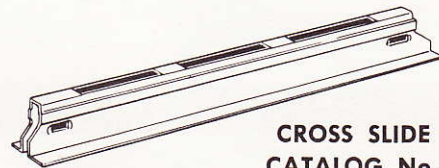

CROSS SLIDE RAIL
CATALOG No. 2729

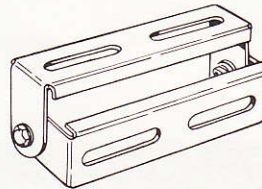

MOTOR MOUNT
CATALOG No. 2730

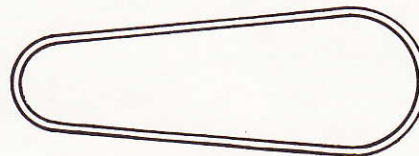

"V" BELT
(ORDER BY
LENGTH NEEDED)

OPTIONAL CASTERS

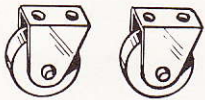

WHEELS
CATALOG No. 2244

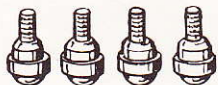

CASTERS
CATALOG No. 2819
(Used on Pedestals only)

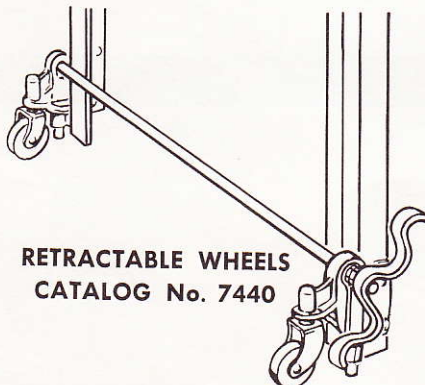

RETRACTABLE WHEELS
CATALOG No. 7440

SPECIFICATION DATA REQUIRED TO MOUNT POWER TOOLS ON BENCH NO. 10525

| Key No. | Tool | Cat. No. | Extra "V" Belt Needed | Extra Cross Slide Rail Needed | Motor Mount Needed |
|---------|----------------------|----------------|-----------------------|-------------------------------|--------------------|
| 1 | Band Saw | *2426 | 43" | None | 1 |
| 2 | Belt Sanders | 2236 | 25" | 1 | 1 |
| 3 | Belt Sanders | 2254 | 30" | None | 1 |
| 4 | Drill Presses | *2450 *2359 | None None | None None | None None |
| 5 | Hack Saws | 2292 2294 | 33" 33" | None None | 1 1 |
| 6 | Jig Saw | 2072 | 54" | None | 1 |
| 7 | Jointer Planer | 2186 | 32" | None | 1 |
| 8 | Shaper | *2394 | None | None | None |
| 9 | Bench Saw | *2428 | None | None | None |

*May also be used with Bench No. 1071.

BAND SAWS

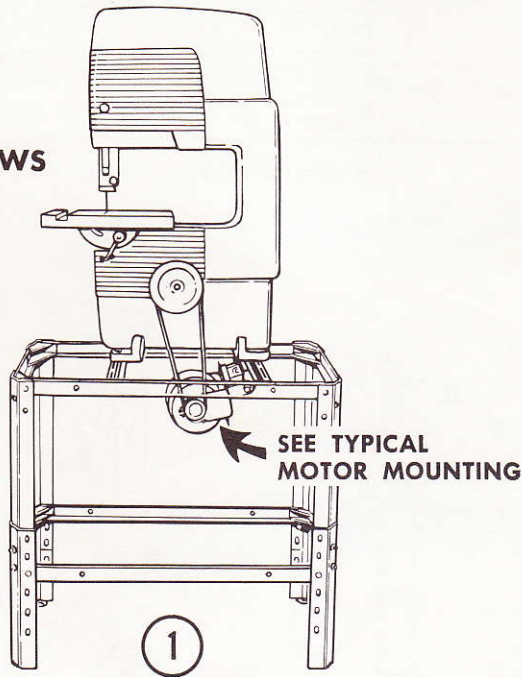

TYPICAL MOTOR MOUNTING

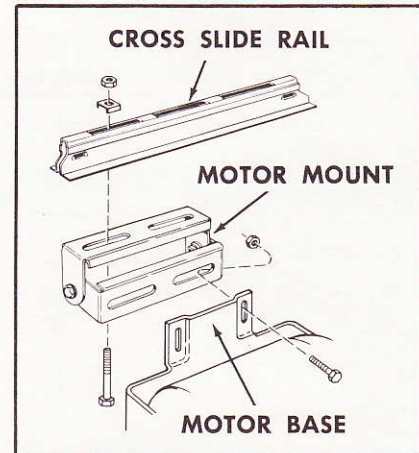

BELT SANDERS

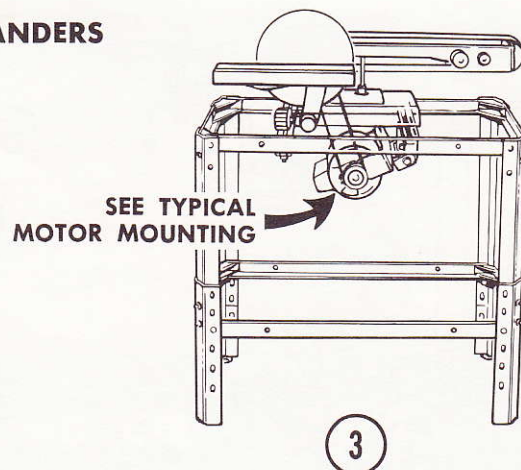
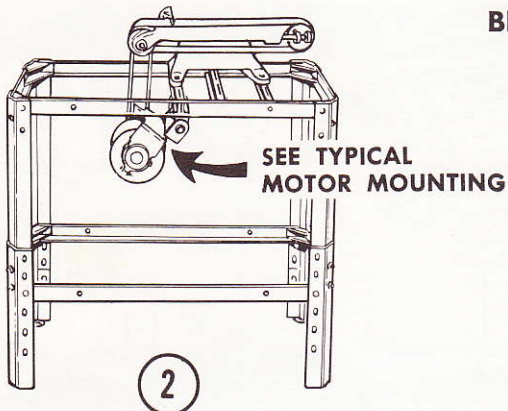

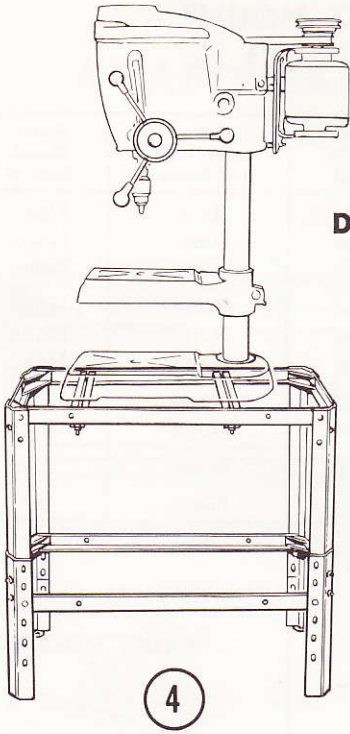

DRILL PRESSES

4

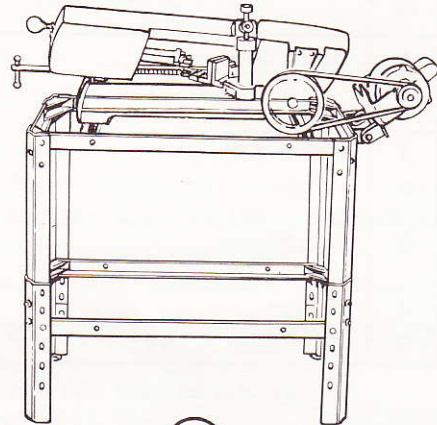

HACK SAWS

5

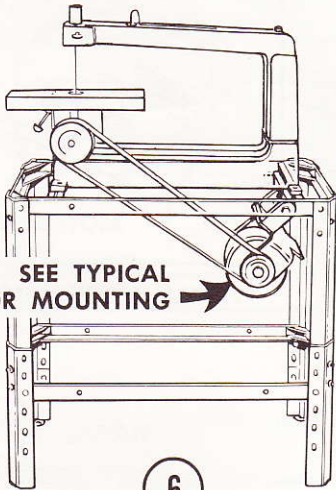

JIG SAW

SEE TYPICAL
MOTOR MOUNTING →

6

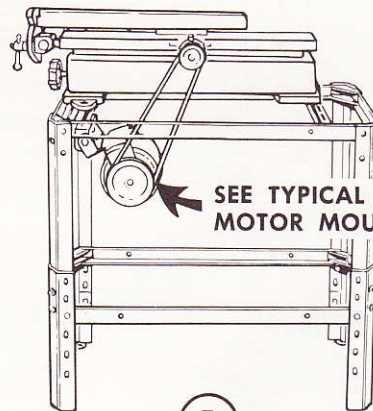

JOINTER PLANER

SEE TYPICAL
MOTOR MOUNTING →

7

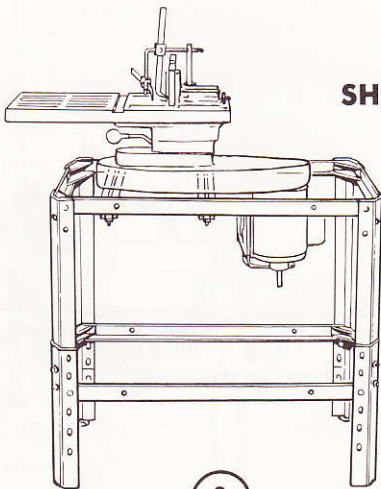

SHAPER

8

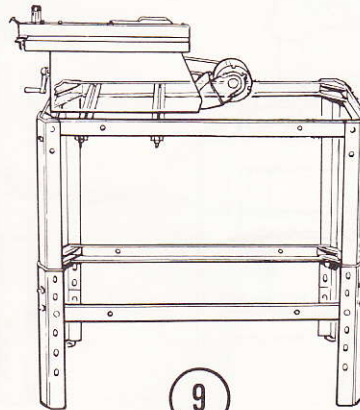

BENCH SAW

9

SPECIFICATION DATA REQUIRED TO MOUNT POWER TOOLS ON BENCH NO. 1071

| Key No. | Tool | Cat. No. | Extra "V" Belt Needed | Extra Cross Slide Rail Needed | Motor Mount Needed |
|---------|-----------------------|----------|-----------------------|-------------------------------|--------------------|
| 1 | Bench Saws | 2999 | None | None | None |
| | | 2990 | None | None | None |
| | | *2428 | None | None | None |
| 2 | Radial Arm Saws | 2935 | None | None | None |
| | | 2940 | None | None | None |
| | | 2941 | None | None | None |
| 3 | Drill Presses | *2450 | None | None | None |
| | | *2359 | None | None | None |
| 4 | Shaper | *2394 | None | None | None |
| 5 | Band Saw | *2426 | 43" | None | 1 |

*May also be used with Bench No. 10525.

BENCH SAWS

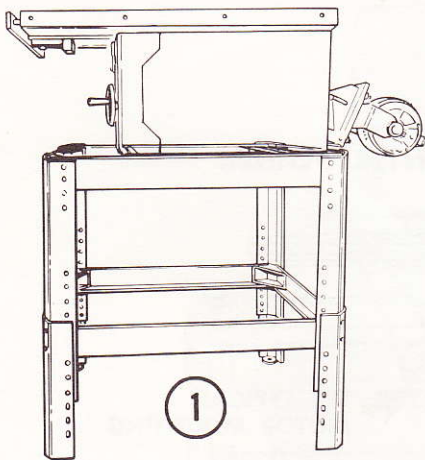

RADIAL ARM SAWS

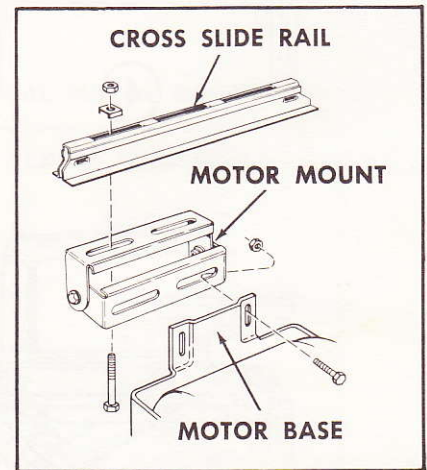
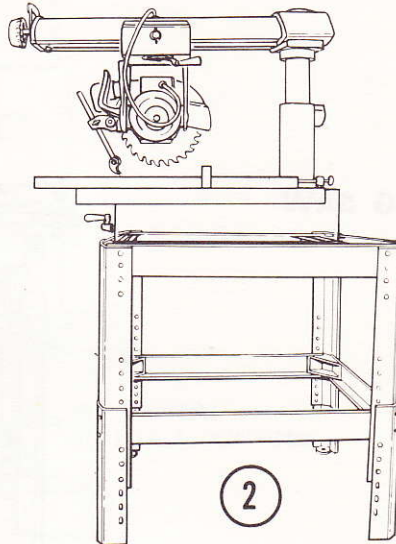

TYPICAL MOTOR MOUNTING

DRILL PRESSES

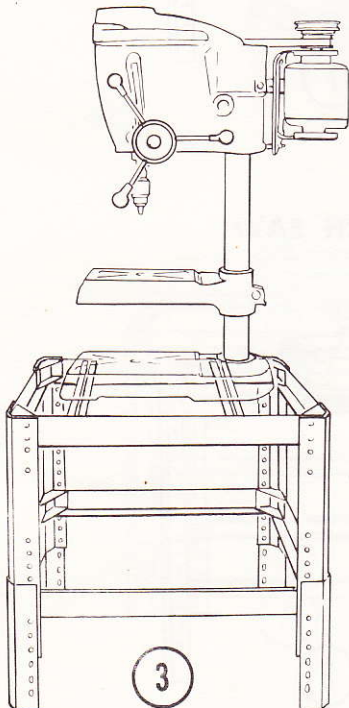

SHAPER

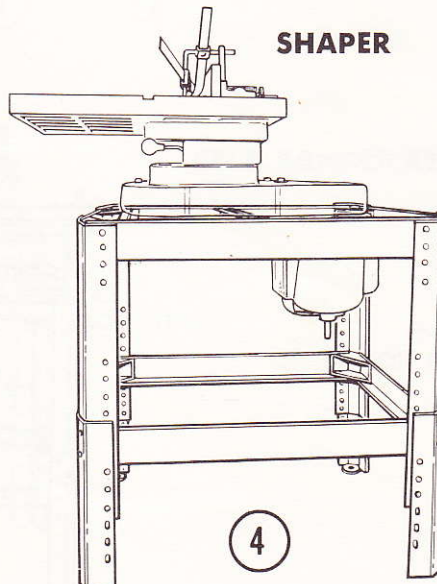

BAND SAW

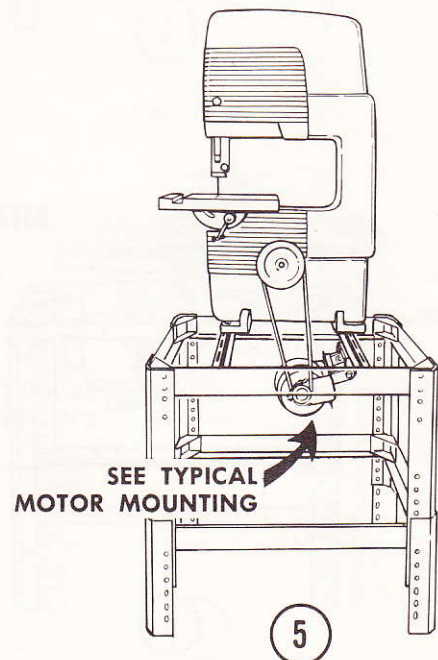

CRAFTSMAN PEDESTAL-TYPE TOOL STANDS

Craftsman Pedestal-Type, power-tool stands combine big, brawny strength with minimum space requirements. The heavy cast-iron base gives each stand maximum stability while the rigid tubular steel column and cast-iron brackets maintain the mounted tool precisely level.

The motor mount clamps securely to the tubular column, enabling the motor to be positioned directly under the tool or at the rear. A Tool Stand Guard (sold separately—see table below) provides safety protection from drive belts.

NOTE

When fitted with casters (see page 2) any pedestal type stand can be moved readily around the shop.

| PEDESTAL TYPE TOOL STANDS | | | | Tool Stand Guards (catalog no.) |
|---------------------------|----------|---------------------------|------------------|------------------------------------|
| Key No. | Cat. No. | Fits Tool | Tool Catalog No. | |
| 1 | 2964 | Grinder | 1957, 1958, 1959 | None |
| 2 | 2249 | Wood Turning Lathe | 2162, 2388 | None |
| 3 | 2225 | Wood Shaper | *2394** | None |
| 4 | 2204 | Six-Inch Sander | *2254 | 2251 |
| 5 | 29602 | 6-1/8-Inch Jointer-Planer | 2062 | 29082 |
| 6 | 2228 | 10-Inch Bench Saw | 2990** | None |
| | | 10-Inch Bench Saw | 2999** | None |
| | | 8-Inch Bench Saw | *2428** | None |
| 7 | 2957 | Two-Wheel Band Saw | *2426** | 2907 |

*May also be used with Bench No. 10525

**May also be used with Bench No. 1071

