

CAT. NO. 9-2340
VARI-SLO SPEED CONTROL ATTACHMENT
OPERATING INSTRUCTIONS
FOR CRAFTSMAN DRILL PRESSES CAT. NOS. 2313 AND 2314

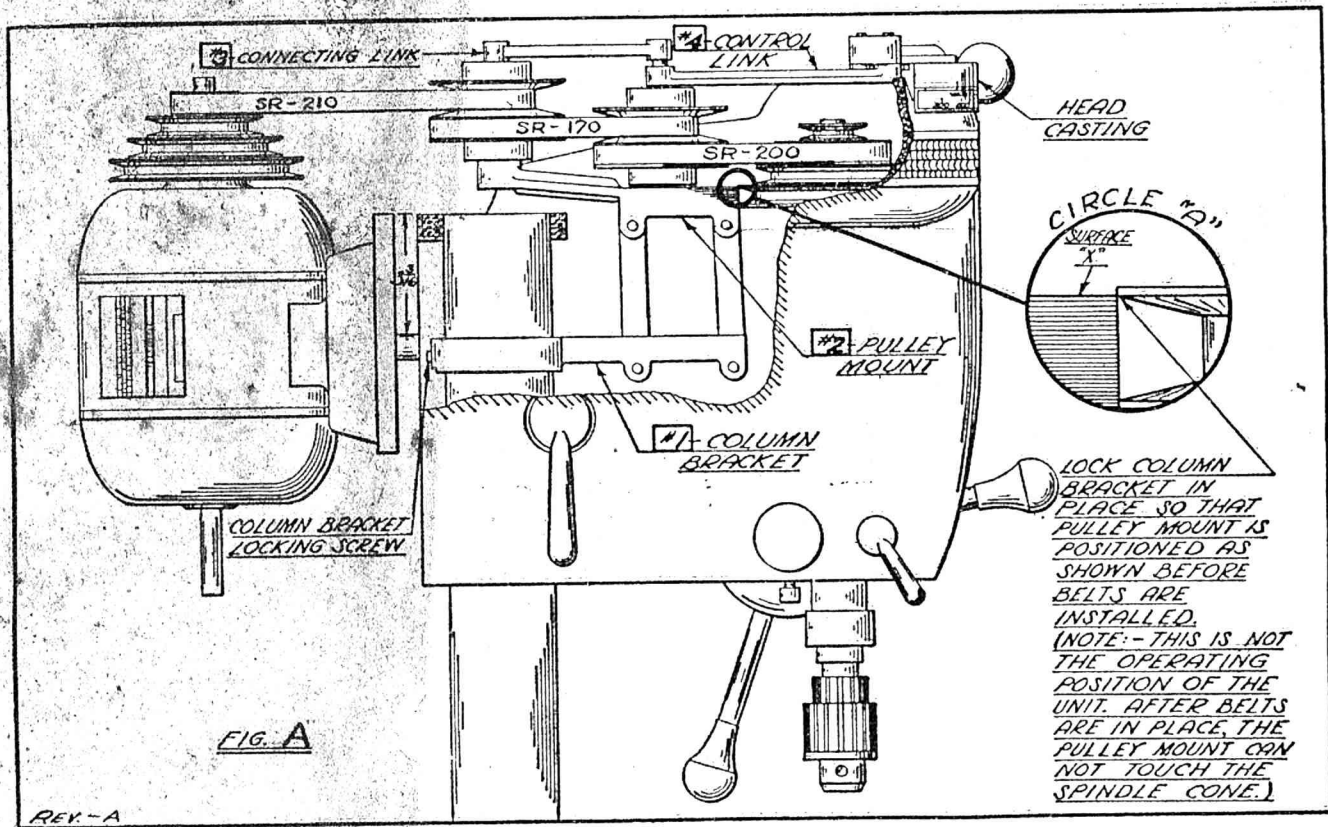

The Vari-Slo Speed Control attachment, when properly installed on either of the above listed drill presses, slows the original lowest speed of 625 R.P.M. down to 300 R.P.M. and gives any speed desired from 300 R.P.M. to 3750 R.P.M. quickly, with no belt changing. The operator can read the correct spindle speed directly from the indicator dial, and can change the R.P.M. quickly to any indicated speed from 300 to 3750 R.P.M.

INSTALLATION:

Remove the stamped metal cap from the top of the drill press column. Remove the motor and the motor base from the drill press. Raise the top of the drill press head about 4 inches above the top of the column. Insert the Vari-Slo Speed Control, with pulleys in place, into the drill press head so that the Column Bracket (#1) fits around the drill press column. (See Fig. A) Push the drill press head until the top of the head is with the top of the column and lock in place. Fit the pulleys of the Vari-Slo Speed Control forward until the Pulley Mount (#2) touches the step cone pulley on the spindle of the drill press. Raise or lower the Column Bracket (#1) on the drill press column until the top surface "X" of Pulley Mount (#2) is in line with the top edge of the largest groove of the spindle cone pulley as shown in Circle "A", Fig. A. When the Pulley Mount (#2) is in this position, adjust the Vari-Slo Speed Control on the drill press Column until its two pulleys are in direct line with the spindle

pulley. Be sure the top surface "X" of Pulley Mount (#2) is in line with the top edge of the lower groove of the spindle pulley as shown in Circle "A", Fig. A, and lock the Column Bracket Locking Screw against the drill press column with the hexagon wrench supplied with the attachment. With the pulleys of the Vari-Slo Speed Control still pushed forward, place the SR-200 V-belt in the bottom groove of the front pulley and around the second groove from the top of the drill press spindle pulley as shown in Fig. A. The second belt, SR-170, should be running from the bottom groove of the back pulley on the Vari-Slo Speed Control to the top groove of the front pulley (Fig. A).

Take the Head Casting Assembly, loosen the Control Knob, and make sure the Clamping Pad is in place as shown in Fig. C. Place the Head Casting Assembly on top of the most forward part of the drill press head, with the Control Link (#4) over the shaft of the front pulley of the Vari-Slo Speed Control as shown in Fig. A. This is done by slipping the Control Link (#4) over the front pulley shaft at the same time the Head Casting is seated on the drill press head with the Flat-Head Screws behind the drill press casting as shown in the cut-away view in Fig. D. This creates a clamp so that the Head Casting may be locked firmly in place. When the Head Casting is centered on the drill press head, lock in place by tightening the Lock Screw just above the Nameplate (Figs. B & D) with the hexagon wrench supplied. If the top of the drill press head is uneven, the Head Casting Assembly may be leveled by adjusting the two Leveling Screws as shown in Figs.

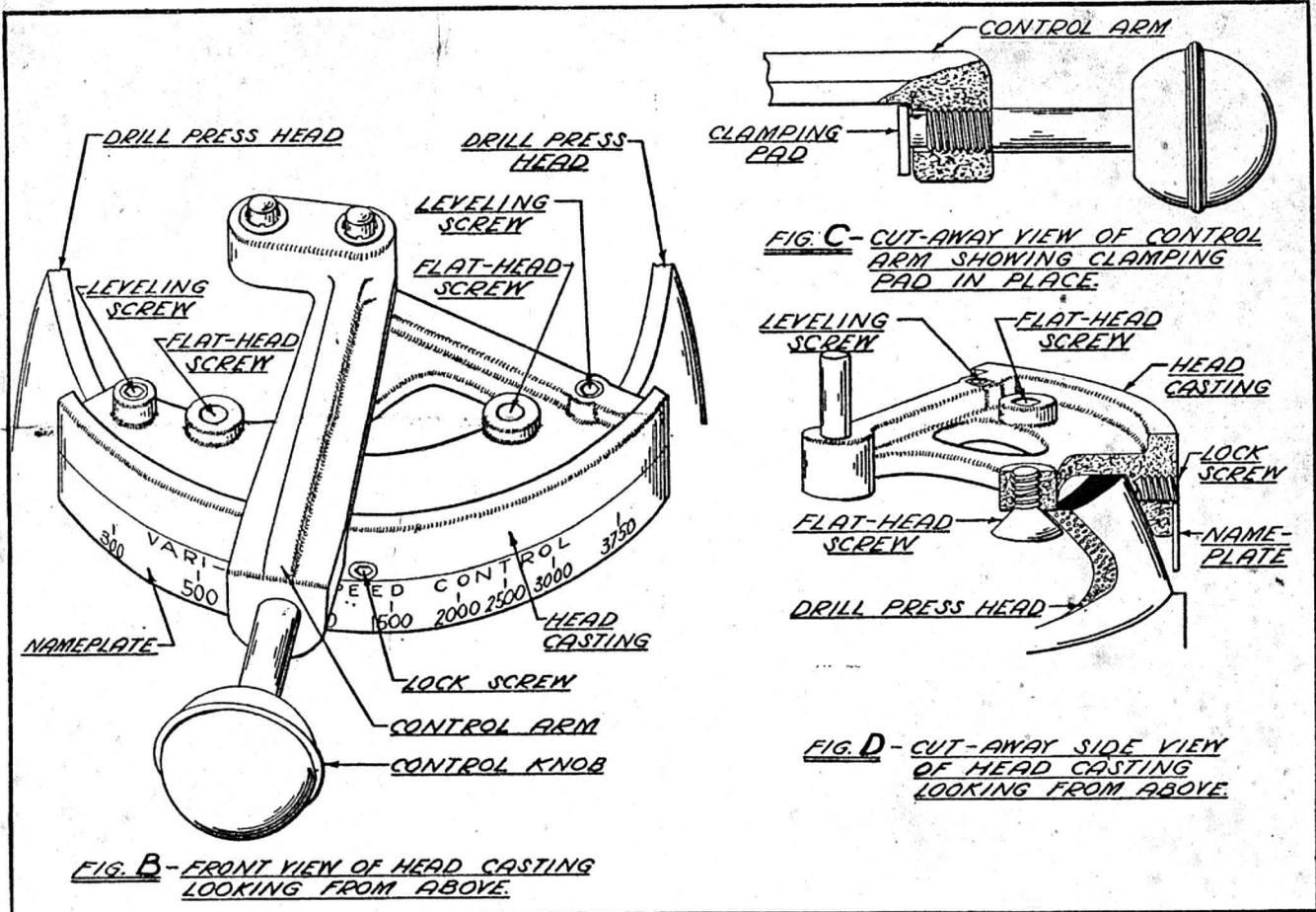

B & D. Caution: Do not tighten Leveling Screws so much that the Flat-Head Screws are raised out of place.

Replace motor and motor base to the measurements shown in Fig. A. The smallest step of the cone pulley on the motor should be at the top. (The above condition and measurements are for a Craftsman motor only. If other than a Craftsman motor is used, the motor may be shifted up or down on the motor base, the motor base inverted, and/or the motor pulley inverted in order to line up the smallest groove of the motor pulley with the top groove of the rear pulley of the Vari-Slo Speed Control.) Place the SR-210 V-belt in the top groove of the rear pulley of the Vari-Slo Speed Control and around the smallest groove of the motor pulley. Place the Connecting Link (#3) over the two shafts of the Vari-Slo Speed Control (Fig. A). Raise or lower the motor pulley until the SR-210 V-belt is level. Gently lock the Control Arm by turning the Control Knob in a clockwise direction. Turn on the motor switch and, with the drill press running, move the motor base back until proper tension on the V-belts is obtained and lock motor in place. V-belts should not be placed under undue tension. Further adjust the motor pulley so that the SR-210 V-belt is level and does not rub the next groove of the motor pulley.

To set the indicator pointer with the speed of the drill press spindle, start the drill press and move the Control Arm to its extreme leftward position and hold without

locking. If the indicator pointer does not read 300 R.P.M., loosen the Lock Screw above the Nameplate and move the Head Casting right or left to line up 300 R.P.M. with the indicator pointer, and then lock in place. This procedure may be repeated whenever belt stretching causes the indicator pointer to read improperly.

OPERATION:

The Vari-Slo Speed Control is operated simply by turning the Control Knob counter-clockwise to loosen and moving the Control Arm to the left or right until the indicator pointer is pointing to the speed you desire. Gently lock by turning the Control Knob clockwise. Due to the design of the Control Lever it is not necessary to tighten the Control Knob too tight. Also be sure the Control Knob is loosened enough to allow the Clamping Pad to move freely before the Control Arm is moved. *All speed changes are to be made with the drill press running.*

The pulleys of the Vari-Slo Speed Control are packed with grease for internal lubrication and also have self-lubricated ball bearings. When the unit is first used, the normal heat created may cause the grease to expand and push out at the ends. However, do not become alarmed as this is a normal condition with self-lubricated bearings. When the grease has fully expanded, no more will be forced out and the proper amount for good lubrication will remain.