



OPERATING INSTRUCTIONS AND PARTS LIST FOR CRAFTSMAN DRILL PRESS

MODEL NUMBER 103.24500 & 103.24510

The model number of your Drill Press will be found on a plate located on the base near the column. Always mention this number when communicating with us regarding your Drill Press, or when ordering parts.

HOW TO ORDER REPAIR PARTS

All parts listed herein may be ordered through SEARS, ROEBUCK AND CO. or SIMPSONS-SEARS LIMITED. When ordering parts by mail from the mail order house which serves the territory in which you live, selling prices will be furnished on request or parts will be shipped at prevailing prices and you will be billed accordingly.

WHEN ORDERING REPAIR PARTS, ALWAYS GIVE THE FOLLOWING INFORMATION AS SHOWN IN THIS LIST.

- | | | |
|---------------------|----------------------|--------------|
| 1. The PART NUMBER. | 3. The MODEL NUMBER. | 103.24500 or |
| | | 103.24510 |
| 2. The PART NAME. | 4. The NAME of item. | DRILL PRESS |

COAST TO COAST NATION-WIDE SERVICE FROM SEARS FOR YOUR CRAFTSMAN POWER TOOLS



SEARS, ROEBUCK AND CO. and SIMPSONS-SEARS LIMITED in Canada back up your investment with quick, expert mechanical service and genuine CRAFTSMAN replacement parts.

If and when you need repairs or service, call on us to protect your investment in this fine piece of equipment.

SEARS, ROEBUCK AND CO. - U.S.A. IN CANADA, SIMPSONS-SEARS LIMITED

OPERATING INSTRUCTIONS AND PARTS LIST FOR DRILL PRESS

MODEL NUMBER 103.24500 AND 103.24510

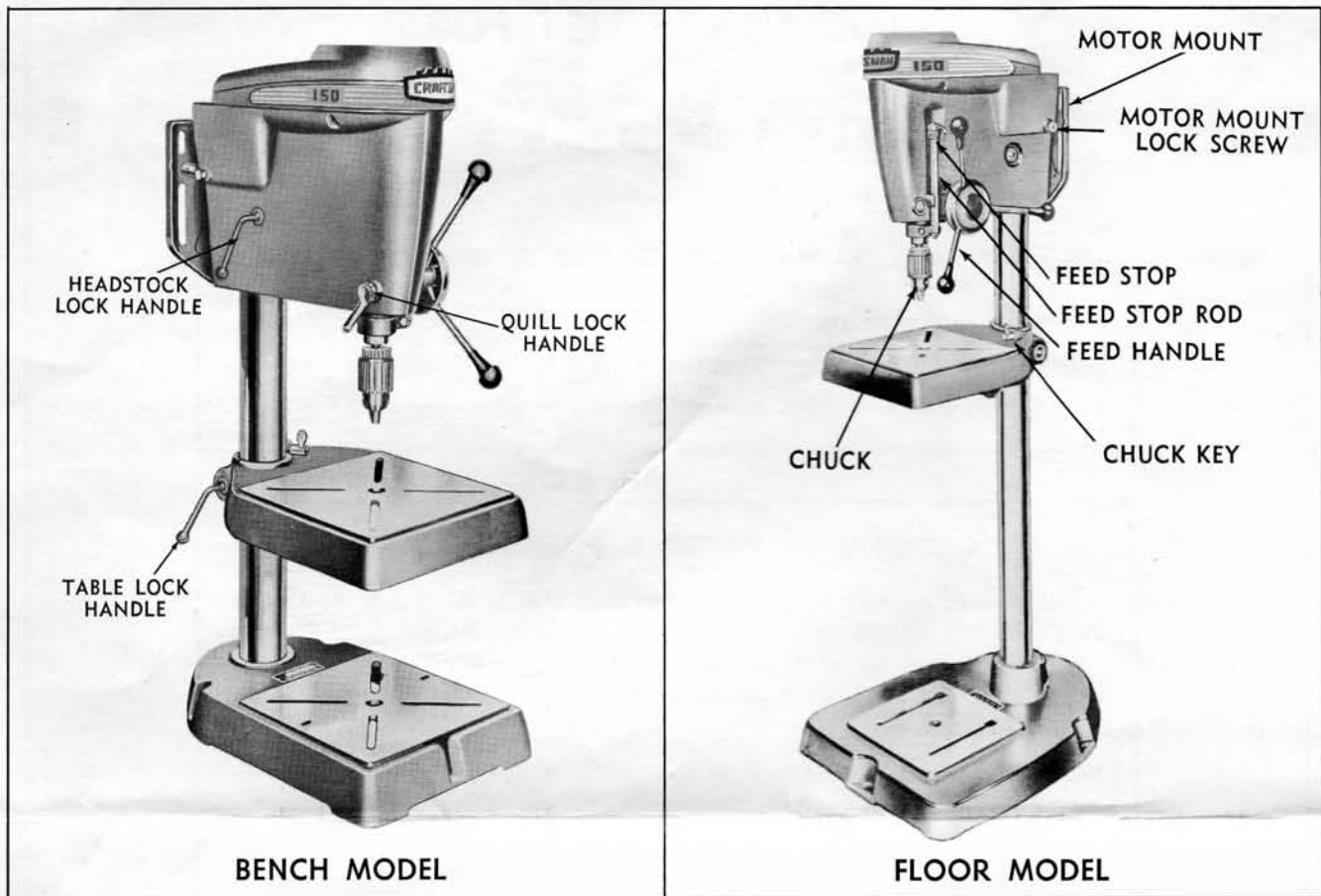

FIGURE 1

This drill press has been planned to give you the utmost in precision and efficiency of operation. Quality material coupled with rigid manufacturing standards are maintained to give you the high standard of quality found in this tool. The chuck furnished has a collar attached which will keep it firmly seated on the spindle taper for all operations especially where side thrust on the cutting tool, such as routing, might loosen the chuck.

Exterior styling of the head on this drill press encloses the revolving mechanism for safety, yet leaves the belt readily accessible for changing to obtain different spindle speeds.

All features combine to give you maximum trouble free service.

To prevent damage or loss in shipment some of the parts were disassembled from the tool. These parts are listed below. Be sure they are all accounted for before discarding any of the packing materials.

Box located under table contains:

1. Item No. 59, V-belt.
2. Item No. 28, Chuck key.
3. Item No. 60, Motor pulley with set screw.
4. Item No. 27, Chuck.
5. Three assemblies, each consisting of Item No. 53, Feed handle rod. Item No. 52, Feed handle knob.

6. Items No. 39, 40 and 41, Bumper and Stud Assembly.
7. Paper bag contains:
 - Item No. 14, Hex wrench 3/32.
 - Item No. 62, Hex wrench 5/32.
 - Item No. 41, 4 pcs. Motor bolt nuts.
 - Item No. 46, 8 pcs. Motor bolt washers.
 - Item No. 47, 4 pcs. Motor bolts.
 - Items No. 34, 35, 36 and 37 assembled.

ASSEMBLY:

Place **feed handles** on tool as shown in Fig. 1.

Clean taper on spindle and the tapered socket in chuck body. Be sure they are free of any particles which might not allow proper seating. Apply a film of light oil to both spindle taper and chuck socket. Place chuck on end of spindle and screw the collar onto the threaded portion of the spindle. Tap the chuck body, **not jaws**, from below with a piece of wood to firmly seat it on spindle, then tighten collar. The collar does not need to be excessively tight as it has a tendency to tighten when drill press is running.

Place the chuck key in the hole provided at side of table support, see Fig. 1.

Keep the Hex wrenches in a handy place near the tool.

INSTALLATION:

Three 13/32 inch diameter holes have been provided in the base through which bolts or screws may be inserted to secure the drill press to a well constructed bench or tool stand.

To install motor loosen the **motor mount lock screws**, Fig. 1, until the **motor mount** may be removed. Fasten the motor to the motor mount with the bolts, nuts, and washers provided so that when motor mount is reinstalled on the tool, the larger portion of the mount will be down. For convenience, if your motor has a switch, and rotation will be correct, place motor on motor mount so that the switch is on the left side. **Direction of rotation of the spindle must be clockwise when viewed from pulley end of spindle.**

Mount the motor pulley, No. 60, on motor shaft so that the small diameter is at bottom. For normal speeds, the largest groove on the motor pulley should be in line with the smallest groove on the spindle pulley, No. 1.

Tighten the pulley set screw with the larger Hex wrench, No. 62. If your motor shaft has a flat on it, position the pulley so that the set screw will tighten against the flat.

Place belt around the pulleys and tighten, not excessively, by sliding the motor mount away from tool. Tighten the motor mount lock screws to maintain this tension.

Adjust the screw, No. 40, until the center line of the motor is parallel with the center line of the column.

MOTOR:

A 1/3 horsepower 1750 R.P.M. **ball bearing** motor will provide sufficient speed and power for your drill press on general work. For continuous heavy duty operation a 1/2 horsepower motor is recommended.

SPEED:

The spindle speeds obtainable with these 4 step pulleys are shown in Fig. 2.

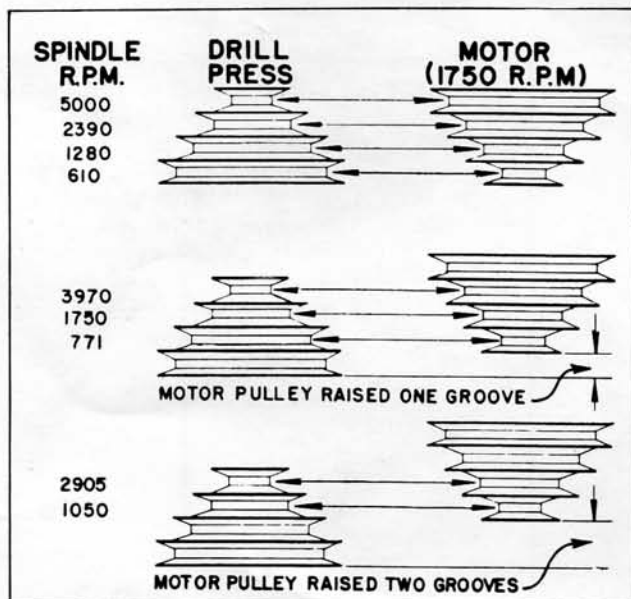

FIGURE 2

For slower speeds use a Multi-Speed Attachment available from your nearest Sears retail store or mail order house. Ask for Catalog No. 9A-2338.

LUBRICATION:

The spindle and pulley bearings have been packed with lubricant and will require no further attention for the life of the bearing.

Place a few drops of oil occasionally on the pinion shaft, No. 72. The oil hole is located in the hub on the right hand side of the head.

To maintain smoothness of operation and to prevent rust, occasionally apply a small amount of light cup grease to the quill while in a down position. With quill still fully extended, reach into the backside of the head and apply grease to the spindle, below the pulley, and to the upper portion of the quill.

Occasionally wipe the column, table and base with an oil soaked rag to prevent rust and maintain smooth sliding action.

CONTROLS:

The **chuck** is a key-type and has a capacity of 0-1/2 inch diameter. It is equipped with a lock collar to retain it on the spindle. This eliminates the necessity of having collet chucks for such tools that develop side thrust while in operation, such as routers.

The **feed stop unit** provides a means of presetting hole depths before drilling or for drilling several holes to the same depth.

The **lock screw**, No. 36, when tightened, holds the feed stop collar, No. 37, in place. The two pieces, as an assembly, can be moved on the stop rod for fast positioning by turning the unit a quarter turn and sliding it up or down to an approximate position.

The **feed stop** adjusting collar, No. 34, can then be adjusted to the exact depth desired.

CAUTION: The top of the adjusting collar should never be more than 1/8" away from the shoulder of the feed stop collar after an adjustment has been made. If the desired adjustment can not be made within the 1/8" allowance, reposition the unit and adjust the feed stop adjusting collar.

The **feed stop rod** is a gauge, with 5 inches of 1/16 inch graduations, carrying the feed stop and lock nut.

The **feed handle** is used to raise and lower the chuck 4 inches. It has an automatic spring loaded return action.

The **quill lock handle** when tight holds the quill at any depth of cut for such operations as shaping, routing, surface grinding, etc. Always release the quill lock before changing position of quill.

The **table lock handle** and **headstock lock handle** control the barrel locks which grip the column. When releasing either of these handles do so with care. Support the part you wish to adjust so that it will not drop too rapidly causing damage to the tool.

The **motor mount** has been hinged in order to make the changing of spindle speeds easier. The hinge action incorporated in this motor mount will allow quicker belt changes. To move the belt from one pulley groove to another, pivot the motor forward and slip the belt into the desired grooves.

ADJUSTMENTS:

The following adjustments may be necessary to keep your drill press at its most efficient operation.

If the automatic feed return fails to return the chuck to the top of the stroke or if the return action becomes sluggish, the tension may be adjusted as follows;

1. Lock the quill at the top of its stroke with quill lock handle.
2. Holding the feed handles pull pinion ass'y No. 72 straight out until it is dis-engaged or free to turn. Then turn handles counterclockwise approximately one-half turn and re-engage pinion.
3. Release quill lock handle and check tension. If return tension is still not sufficient repeat the above adjustment until it is.

To change the locked position of table lock handle or headstock lock handle (Fig. 1), remove handle and rotate table lock, item 66, or headstock lock, Item 51, 180°. Re-insert and tighten lock handle.

CAUTION: Headstock or table assembly should be securely supported when changing locked position of handles.

The **Quill Lock Handle**, (Fig. 1) for greatest ease of operation should point **down** when **locked**. To change the position of the handle, loosen the set screw, remove handle from hex head screw and rotate to correct position. Replace handle and tighten set screw.

Belt tension adjustment is made by loosening the motor mount lock screws and moving the motor mount away from the tool. Excessive tension shortens bearing life, causes excessive belt wear and robs the motor of power. Tension should be just enough to prevent slippage at normal operating speeds and feeds.

Tighten pulley set screws after a few hours operation.

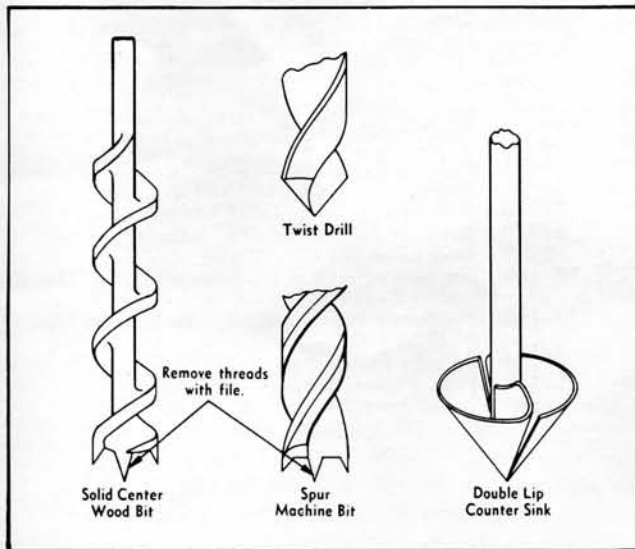

FIGURE 3

TYPES OF BITS:

A variety of bits are available for use in your drill press.

For metal drilling the standard twist drill will prove adequate for the home work shop. If exten-

sive commercial operations are to be performed, high speed steel drills although more expensive, will prove to be the better tool as higher operating speeds are possible plus longer cutting edge life.

The solid center wood bit has a single flute turning around a solid center but carries two spurs.

The fluted bit is an excellent all purpose wood bit. It has two flutes each terminating in a cutting edge and spur.

The best bit for high quality machine drilling in wood is the spur machine bit. It is the stiffest drill, tracks nicely and produces an exceptionally smooth hole.

For larger holes, a hole saw is available for either metal or wood. This bit has a center drill for pilot and teeth around the outer rim similar to a saw blade.

Also, for large holes in wood an expansion bit may be used. When the expansion bit or any hand wood bit is used in the drill press, the screw point must have the threads removed from it so that it will not enter the wood too rapidly. These threads may be filed off. (See Fig. 3.)

Countersinking in wood may best be accomplished by using the double lip style. It will give the cleanest cut and will not gum up under continuous operation.

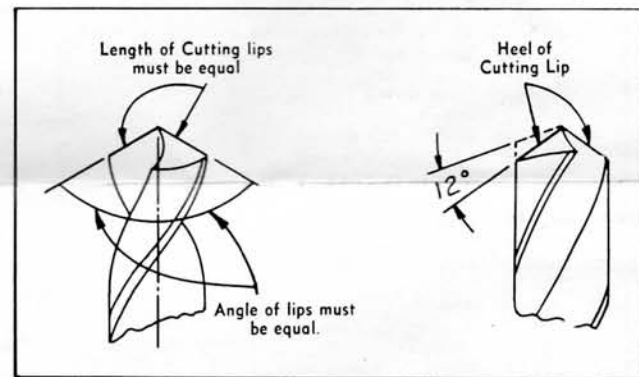

FIGURE 4

DRILL SHARPENING:

When grinding twist drills, in order to maintain the efficiency of the drill, extreme care should be exercised. The dead center of the point must be maintained, that is, the cutting lips must be the same length, Fig. 4. Also their angle in relation to the center line of the drill must be equal. The angle should be approximately 60 degrees, 120 degrees included, for metal and 35 degrees, 70 degrees included, for wood. The cutting lip should be relieved gradually behind the cutting edge so that the clearance at the heel is about 12 degrees.

OPERATION:

Chuck removal;

If at any time you wish to remove the chuck merely loosen the chuck holding collar and continue to turn it. This will force the chuck from the spindle taper. Do not attempt to drive or wedge the chuck off as you may damage the spindle or bearings.

For extensive use on woodworking, an auxiliary table of 3/4 inch plywood will prove its worth in added work area and the protection from shifting of your work. Fasten the plywood table to the drill press table with countersunk screws. This auxiliary table also provides a good surface for mounting a shaping fence, pivot pins and other similar units. It affords protection for the drill press table when drills break through the work piece.

When drilling through wood, a piece of scrap material under the work piece will eliminate splintering and mutilation as the drill point breaks through.

Another method of preserving the surface is to reverse the work piece when the point of drill breaks through and finish the hole from opposite side.

For drilling to a definite depth, such as a blind hole, the feed stop may be set to the desired depth

by lowering the drill to a mark on the edge of the work piece corresponding to the depth of the hole desired.

A straight piece clamped to the table, as a guide or fence, has many uses, as in drilling several holes the same distance from an edge or as a guide for grooving, fluting or milling.

SAFETY:

The work piece should be held securely on the table, either by clamps, pins, or a vise, to prevent its turning with the drill. A drill vise is an inexpensive means of holding many varieties of work and is readily adaptable for use with cylindrical work. The drill vise or a V-block should always be used for cylindrical work. In any case **secure** your work piece as it may break drills and fly off the table.

PARTS LIST

Key No.	Part No.	PART NAME
1	27415	Spindle Pulley
2	18413	Spindle & Pulley Sleeve
3	18212	Pulley Ball Bearing
4	18414	Inner Retaining Ring
5	18415	Outer Retaining Ring
6	38617	Panel Screw
7	38617	Panel Screw
8	27221	Drill Head Frame
9	27727	Panel
10	38632	Quill Lock Sleeve
11	18512	Quill Lock Screw
12	18120	Lock Handle and Set Screw
13	*X-181	Set Screw No. 10-24 x 1/4 Soc. Hd. Cone Point
14	*X-1407	Hex Wrench 3/32
15	27623	Lock Handle
16	38628	Head Lock Sleeve
17	58712	Roll Pin
18	18410	Spindle Collar
19	18429	Washer-Rubber
20	18422	Washer
21	18211	Quill Bearing
22	27625	Quill
23	27813	Quill Gasket
24	*X-277	Cap Screw 1/4-20 x 1 1/2 Hex Head
25	38422	Feed Stop Bracket
26	27130	Spindle Ass'y
27	38623	Chuck
28	**18129	Chuck Key
29	*X-413	Hex Nut Jam 3/8-16
30	*X-420	Hex Nut 1/4-20
31	*X-605	Lock Washer 1/4 Amer. Std.
32	27812	Retaining Ring
33	27627	Feed Stop Rod
34	27631	Feed Stop Adjusting Collar
35	38881	Spring
36	27628	Lock Screw
37	27629	Feed Stop Collar
38	*X-170	Set Screw 5/16-18 x 1/2 Soc. Hd. Cone Pt.
39	27814	Bumper

Key No.	Part No.	PART NAME
40	27632	Threaded Stud
41	*X-417	Hex Nut 5/16-18
42	38790	Motor Support Base
43	38460	Motor Mount Ass'y Complete
44	*X-417	Hex Nut 5/16-18
45	38876	Roll Pin
46	*X-601	Plain Washer 1 1/32 I.D. x 1 1/16 O.D.
47	*X-309	Mach. Bolt 5/16-18 x 1 Square Hd.
48	38692	Rod - Motor Support
49	38692	Rod - Motor Support
50	X-205	Cap Screw 5/16-18-3/4 Hex Head
51	38629	Head Lock
52	18916	Feed Handle Knob
53	27626	Feed Handle Rod
54	38452	Washer-Fiber
55	38989	Feed Return Spring
56	27617	Pin
57	38631	Quill Lock
58	*X-565	Mach. Scr. #8-32 x 3/4 Rd. Head
59	**X-1459	V-Belt 1/2 x 44 Inches Long
60	38390	Motor Pulley with Set Screw
61	*X-3609	Set Screw 5/16-18 x 1/2 Soc. Hd.
62	*X-1400	Hex Wrench 5/32
63	27219	Table
64	38633	Lock Handle
65	38627	Table Lock Sleeve
66	38626	Table Lock
67	27621	Column for Model 103.24500 Only
	27622	Column for Model 103.24510 Only
68	27370	Base for Model 103.24500 Only
	27380	Base for Model 103.24510 Only
69	38211	Base Lock Shoe
70	*X-185	Set Screw 1/2-13 x 1 1/4 Square Hd. for Model 103.24510
	*X-190	Set Screw 1/2-13 x 1 1/2 Square Hd. for Model 103.24500
71	27104	Spindle Pulley Ass'y.
72	27360	Hub, Pinion, Spring & Pin Ass'y.
	27989	Instruction Sheet and Parts List

For Illustration—See page 6

*Standard hardware items—may be purchased locally.

**Items are regular stock in Sears hardware departments and mail order houses. May also be ordered as repair parts by part number provided.

This sheet is intended for instruction and repair parts only and is not a packing slip. The parts shown and listed may include accessories not necessarily part of this tool.

