

PARTS LIST AND QUICK-CHANGE GEAR

OPERATING INSTRUCTIONS FOR

Craftsman 12-Inch Metal Turning Lathe

Model Number 101.27430 (24" Between Centers)

Model Number 101.27440 (36" Between Centers)

Model Number 101.07403

This is the Model Number of your Lathe. It will be found on the plate located on the rear of the Bed. Always mention this Model Number when communicating with us regarding your Lathe or when ordering parts.

Instructions for Ordering Parts

All parts listed herein must be ordered through a Sears retail store or mail order house. Parts are shipped prepaid, except those marked with an asterisk. When ordering repair parts, always give the following information:

1. The part number in the list.
2. The part name in the list.
3. The model number which is 101.27430 or 101.27440 or 101.07403

Filing Instructions

This list is valuable. It will assure your being able to obtain proper parts service. We suggest you keep it with other valuable papers.

SEARS, ROEBUCK AND COMPANY

QUICK-CHANGE PARTS

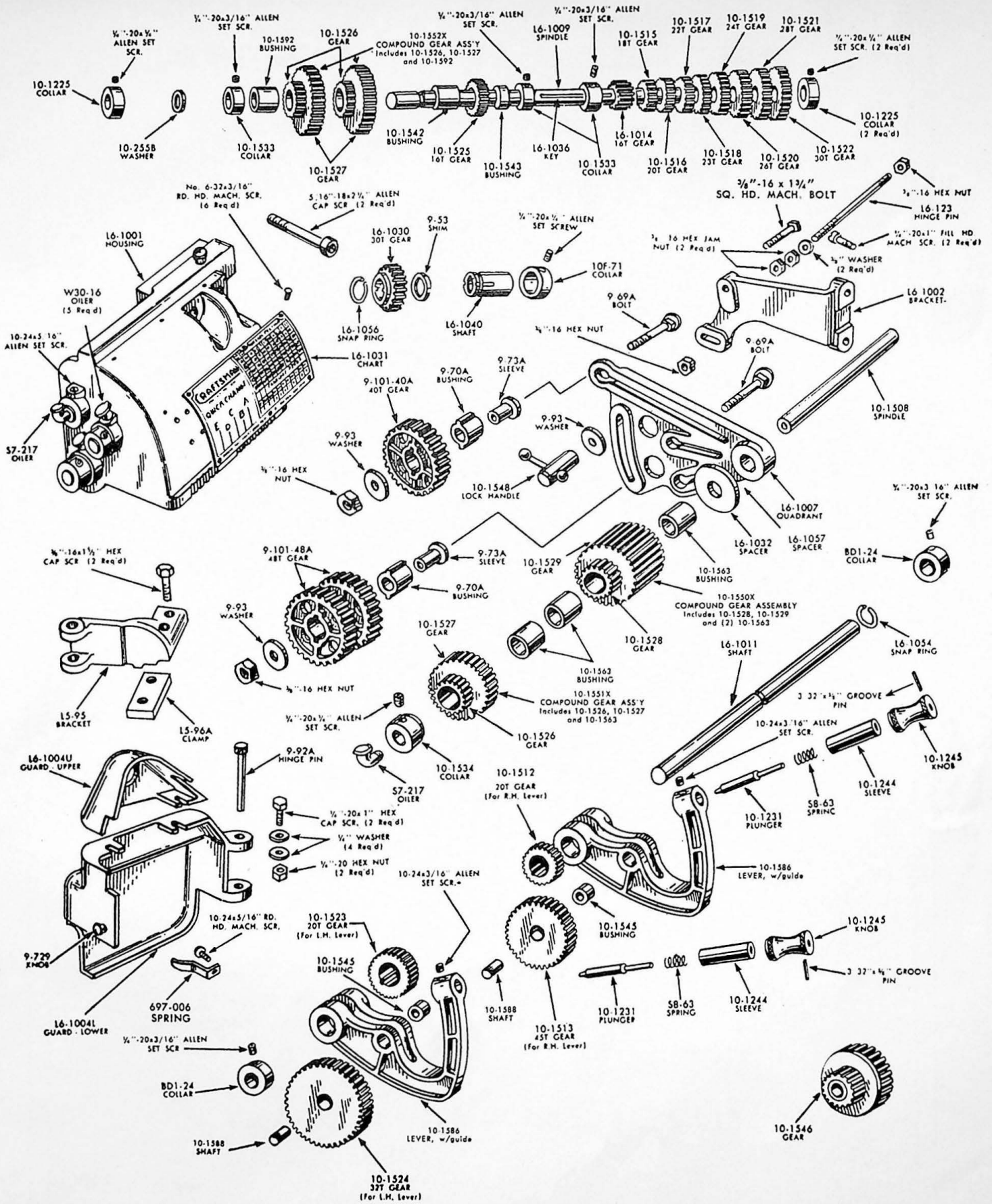

COUNTERSHAFT, BED AND LEAD SCREW PARTS

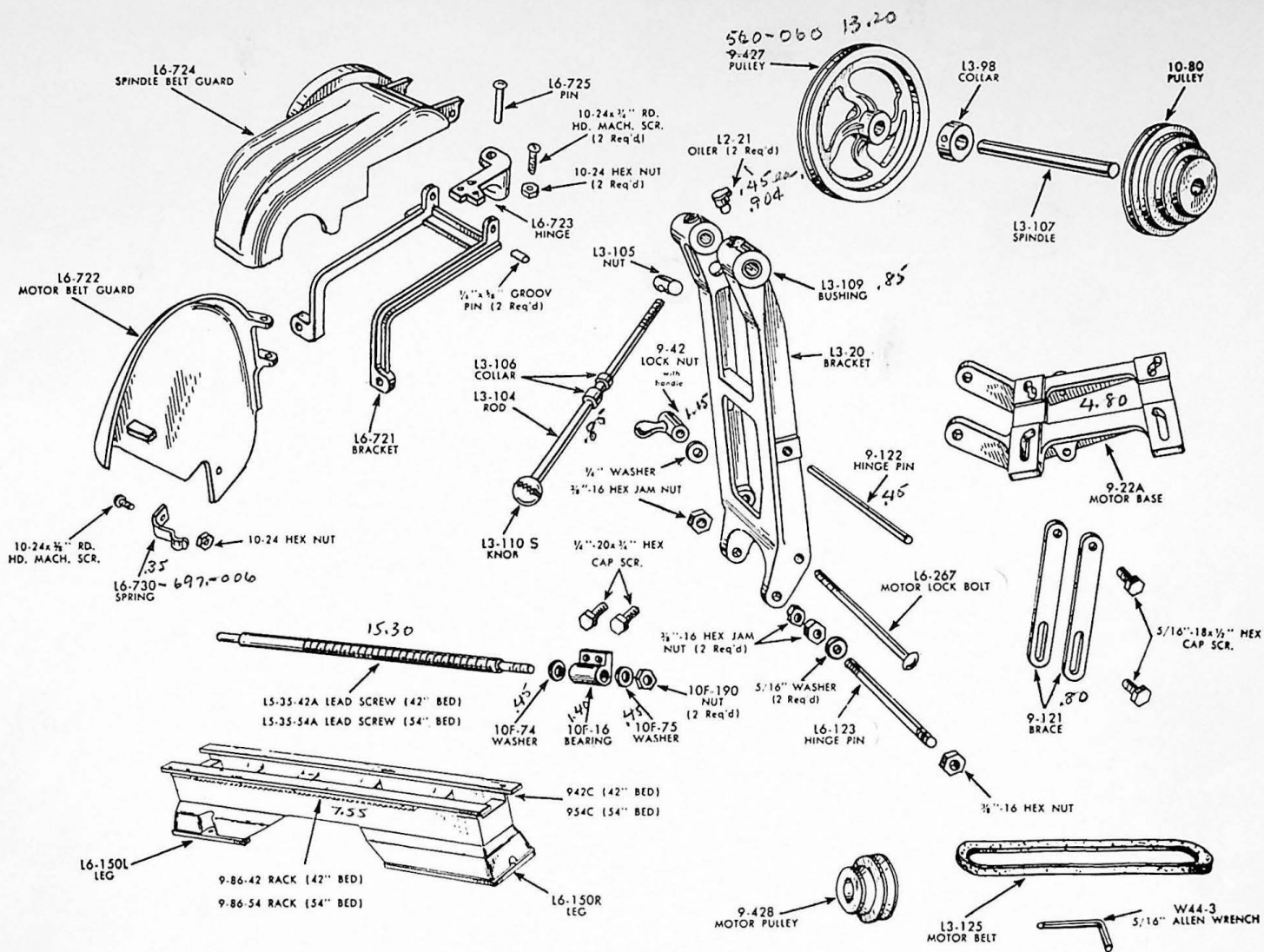

PARTS LIST

When ordering, always give Part Number, Name of Part and Model Number.

All parts are shipped prepaid except those marked with an asterisk (*).

Standard parts, such as bolts, nuts, washers, etc., shown on the picture parts list without part numbers should be purchased locally.

PART NO.	NAME
*942C	42" Bed
*954C	54" Bed
9-7	Tailstock Clamp
9-8	Tailstock Ram
9-13	Split Nut Guide
9-14	Carriage Clamp
9-22A	Motor Base
9-23	Handwheel, with handle (2 Req'd)
9-32	Spindle Collar
9-37A	Carriage Slide Guard
9-39	Tool Post
9-40	Tool Post Washer
9-41	Tool Post Rocker
9-42	Motor Base Lock Nut
9-42A	Ram Lock Nut
9-53	Shim
9-60	Plunger
9-61	Plunger Spring (4 Req'd)
9-62	Threading Dial
9-63	Threading Dial Body
9-64	Threading Dial Gear
9-65	Threading Dial Shaft
9-66	Split Nut Stud (2 Req'd)
9-67	Handwheel Shaft
9-68	Carriage Pinion Shaft
9-69A	Quadrant Gear Bolt (3 Req'd)
9-70A	Quadrant Gear Bushing (3 Req'd)
9-73A	Change Gear Sleeve (3 Req'd)
9-88-42	Carriage Rack, 42" Bed
9-88-54	Carriage Rack, 54" Bed
9-88	Center #2 Morse Taper (2 Req'd)
9-90	Ram Screw Thrust Washer
9-92A	Change Gear Guard Hinge Pin

PART NO.	NAME
9-98	Change Gear Washer (3 Req'd)
9-97	Headstock Clamp
9-100-32	Spindle Gear
9-101-20A	Reverse Tumbler Gear — 20 Teeth
9-101-24A	Reverse Tumbler Gear — 24 Teeth
9-101-32A	Change Gear (2 req'd)
9-101-36A	Change Gear
9-101-40A	Sliding Gear — 40 Teeth
9-101-44A	Change Gear
9-101-46A	Change Gear
9-101-48A	Quadrant Gear — 48 Teeth (2 Req'd)
9-101-52A	Change Gear
9-101-54A	Change Gear
9-101-56A	Change Gear
9-101-64A	Change Gear (2 req'd)
9-102-12S	Carriage Traverse Gear (2 Req'd)
9-102-24	Carriage Traverse Gear (2 Req'd)
9-103	Handwheel Handle (3 Req'd)
9-104	Cross Feed Wheel Handle (4 Req'd)
9-113A	Feed Screw Gear Spacer (2 req'd)
9-114	Feed Screw Gear Stud Washer
9-115	Combination Wrench
9-121	Motor Base Brace (2 Req'd)
9-122	Motor Base Hinge Pin
9-124	Set Screw Plug
9-136A	Tool Post Anchor
9-137A	Tool Post Anchor Stud
9-138	Center Sleeve
9-139L	Tool Holder
9-148	Tool Post Set Screw
9-154	Change Gear Guard Latch Handle
9-155	Threading Dial Screw Washer (2 Req'd)
9-157	Latch Spring

PARTS LIST (Cont'd)

PART NO.	NAME	PART NO.	NAME
9-165A	Tailstock Ram Set Screw, w/nut	10F-55	Carriage Bearing Plate (rear)
9-179	Threading Dial Screw (2 Req'd)	10F-57	Carriage Gib
9-190	Special 3/8" - 16 Hex Jam Nut (5 Req'd)	10F-62	Graduated Dial (2 Req'd)
9-204	Oil Cup (2 Req'd)	10F-71	Collar (2 Req'd)
9-210	3/16" Steel Ball (3 Req'd)	10F-74	Feed Screw Thrust Washer (left)
9-214	Cord	10F-75	Feed Screw Thrust Washer (right)
9-304	Tool Post Slide Gib	10F-81	Cross Feed Mitre Gear Bearing, with bushing
9-306	Feed Screw Nut	10F-82A	Cross Feed Mitre Gear
9-307	Thrust Plate	10F-83	Cross Feed Mitre Gear
9-427	Countershaft Pulley	10F-84	Cross Feed Gear Shift Knob
9-428	Motor Pulley, 1/2" bore	10F-85	Gear Bearing Shim
9-729	Knob	10F-129	Shift Gear Shaft
10-29	Split Nut Lever	10F-130	Felt Oiler (4 Req'd)
10-31T	Spindle	10F-131	Wiper (4 Req'd)
10-42A	Pulley Index Pin	10F-132R	Wiper Retainer (2 Req'd)
10-56	Cross Feed Gib	10F-132L	Wiper Retainer (2 Req'd)
10-79	Spindle Pulley	10F-190	Lead Screw Jam Nut (2 Req'd)
10-80	Countershaft Pulley	10F-305	Compound Rest Feed Screw
10-101-16A	Compound Gear with Bushing	41-43A	Switch Plate
10-167	Back Gear Tension Washer (2 Req'd)	41-44A	Switch
10-225	Gib Screw Nut (8 Req'd)	423-001	Insulator
10-226	Gib Screw Nut (8 Req'd)	697-006	Guard Latch Spring
10-241	Spindle Back Gear	711-001	Shim (.002)
10-242	Spindle Back Gear	711-002	Shim (.003)
10-243	Back Gear	711-007	Shim (.002)
10-244	Back Gear	711-008	Shim (.003)
10-245R	Back Gear Bracket	711-009	Shim (.002)
10-248	Back Gear Sleeve	711-010	Shim (.003)
10-250	Back Gear Shaft	BD1-24	Collar (2 Req'd)
10-251	Back Gear Eccentric (right)	L2-21	Gits Oiler (2 Req'd)
10-252	Back Gear Eccentric (left)	L2-61	Ball Crank, with handle
10-253	Set Collar (2 Req'd)	L3-20	Countershaft Bracket
10-254	Eccentric Handle	L3-27	Screw Stud Bracket
10-256	Back Gear Lock Pin	L3-47A	Spindle Gear Stud
10-257	Back Gear Oil Screw	L3-48A	Reverse Idler Stud (2 Req'd)
10-258	Bushing (3 Req'd)	L3-49	Reverse Idler Stud Washer (2 Req'd)
10-259	Dowel Pin	L3-52A	Screw Stud
10-261	Back Gear Shim (2 Req'd)	L3-58M	Change Gear Bracket
10-262	Headstock Clamp Washer	L3-60	Change Gear Bracket Bolt
10-264	Compound Tumbler Gear Bearing	L3-71A	Change Gear Bracket Bolt
10-301	Compound Rest Swivel (lower)	L3-98	Countershaft Collar
10-302	Compound Rest Swivel (upper)	L3-99D	Countershaft Collar
10-309	Swivel Lock Plunger Pin (2 Req'd)	L3-104	Threading Chart
10-1225	Stack Gear Spindle Collar (3 Req'd)	L3-105	Countershaft Tension Rod
10-1231	Lever Plunger (3 Req'd)	L3-105	Countershaft Tension Rod Nut
10-1244	Lever Sleeve (3 Req'd)	L3-106	Countershaft Tension Rod Collar (2 Req'd)
10-1245	Lever Knob (3 Req'd)	L3-107	Countershaft Spindle
10-1508	Compound Gear Spindle	L3-108	Countershaft Tension Rod Lock
10-1512	Stack Tumbler Drive Gear - 20 Teeth	L3-109	Countershaft Bracket Bushing (2 Req'd)
10-1513X	Stack Tumbler Gear - 45 Teeth, w/bushing	L3-110	Knob, use L3-110S
10-1516	Stack Gear - 18 Teeth	L3-110S	Knob
10-1516	Stack Gear - 20 Teeth	L3-125	Motor Belt
10-1517	Stack Gear - 22 Teeth	L3-303	Tool Post Slide
10-1518	Stack Gear - 23 Teeth	L4-2TA	Headstock
10-1519	Stack Gear - 24 Teeth	L4-5	Tailstock
10-1520	Stack Gear - 26 Teeth	L4-245L	Back Gear Bracket
10-1521	Stack Gear - 28 Teeth	L4-259	Dowel Pin
10-1522	Stack Gear - 30 Teeth	L5-28A	Change Gear Guard
10-1523	Compound Tumbler Drive Gear - 20 Teeth	L5-35-42A	Feed Screw, for 42" Bed
10-1524X	Compound Tumbler Gear - 32 Teeth, w/bushing	L5-35-54A	Feed Screw, for 54" Bed
10-1525	Compound Gear - 16 Teeth	L5-95	Gear Guard Bracket
10-1533	Stack Gear Spindle Collar (3 Req'd)	L5-96A	Gear Guard Bracket Plate
10-1534	Compound Gear Collar	L5-152	Change Gear Guard (inner)
10-1539	Compound Gear Plate	L6-9A	Carriage Apron
10-1543	Compound Gear Bushing	L6-21	Reverse Gear Tumbler
10-1545	Change Gear Tumbler Bushing (4 Req'd)	L6-38	Split Nut Scroll
10-1546	Reverse Tumbler Gear Assembly	L6-123	Countershaft Bracket Hinge Pin
10-1548 X	Lock Assembly	L6-150L	Bench Leg (left)
10-1550X	Compound Gear Ass'y, includes 10-1528, 10-1529 and (2) 10-1263	L6-150R	Bench Leg (right)
10-1551X	Compound Gear Ass'y, includes 10-1526, 10-1527, and 10-1263	L6-263	Plunger Return Spring
10-1552X	Compound Gear Ass'y, includes 10-1526, 10-1527, and 10-1542	L6-264	Spring Spacer
10-1563	Bushing (3 Req'd)	L6-265	Plunger
10-1586	Lever, w/guide (2 Req'd)	L6-267	Motor Tension Lock Bolt
10-1588	Tumbler Lever Shaft (2 Req'd)	L6-721	Belt Guard Bracket
10-1592	Compound Gear Bushing (2 Req'd)	L6-722	Motor Belt Guard
10A-3	Dust Cover (2 Req'd)	L6-723	Outer Belt Guard Hinge
10A-5	Spindle Collar	L6-724	Belt Guard
10A-6	Spindle Spacer	L6-725	1/4" x 2 1/2" Rd. Hd. Rivet
10A-7	Inside Baffle Plate	L6-1001	Gear Housing, w/bushings and oilers
10A-8	Inside Baffle Plate (left)	L6-1002	Housing Support Bracket
10A-9C	Spindle Bearing (front)	L6-1004L	Gear Guard - Lower
10A-11C	Spindle Bearing (rear)	L6-1004U	Gear Guard - Upper
10A-89	Spindle Thrust Collar	L6-1007	Change Gear Quadrant
10D-6	Tailstock Base	L6-1009	Stack Gear Spindle
10D-30	Tailstock Screw Bearing	L6-1011	Gear Tumbler Spindle
10D-34	Tailstock Ram Screw	L6-1014	Stack Gear - 16 Teeth
10D-59	Tailstock Gib	L6-1030	Feed Screw Gear - 30 Teeth
10D-60	Tailstock Gib Adj. Screw (2 Req'd)	L6-1031	Threading Chart
10D-260	Oil Dropper	L6-1032	Compound Gear Spacer
10D-262	Special Ball Crank Nut (2 Req'd)	L6-1036	Stack Gear Spindle Key
10D-308	Compound Rest Ball Crank, w/handle	L6-1040	Feed Screw Gear Shaft
10F-9	Carriage	L6-1054	Tumbler Spindle Retaining Ring, 5/8" hole
10F-11	Traverse Gear Case	L6-1056	Feed Screw Retaining Ring, 1" hole
10F-11X	Traverse Gear Case Assembly	L6-1057	Spacer
10F-12	Split Nut, 1 pr.	LJS-37	Oiler (3 Req'd)
10F-12XS	Half-nut Assembly	M6-44	Tailstock Ram Lock Sleeve
10F-16	Feed Screw Bearing	M6-45	Tailstock Ram Lock Sleeve
10F-17	Mitre Gear Stud	M6-93	Tailstock Ram Washer
10F-19	Carriage Slide Nut	S7-126	Spindle Belt
10F-33	Cross Feed Screw Gear	S7-217	Oiler
10F-36	Cross Feed Slide Screw	S8-63	Lever Plunger Spring (3 Req'd)
10F-45	Feed Screw Bushing (2 Req'd)	S8-88	Compound Tumbler Washer
10F-46	Cross Feed Screw Bearing	W30-16	Oiler (8 Req'd)
10F-54	Carriage Bearing Plate (front)	W44-3	5/16" Allen Wrench

