

Save This Manual
For Future Reference

SEARS

owners manual

**MODEL NO.
113.236110
SCROLL SAW**

Serial
Number 89290R0425

Model and serial number
may be found attached to
the underside of the
worktable.

You should record both
model and serial number
in a safe place for future
use.

CAUTION:

Read **GENERAL**
and **ADDITIONAL**
SAFETY
INSTRUCTIONS
carefully



CRAFTSMAN

16 INCH SCROLL SAW

- *assembly*
- *operating*
- *repair parts*

Sold by SEARS, ROEBUCK AND CO., Chicago, IL 60684 U.S.A.

FULL ONE YEAR WARRANTY ON CRAFTSMAN SCROLL SAW

If within one year from the date of purchase, this Craftsman Scroll Saw fails due to a defect in material or workmanship, Sears will repair it, free of charge.

WARRANTY SERVICE IS AVAILABLE BY RETURNING THE CRAFTSMAN SCROLL SAW TO THE NEAREST SEARS RETAIL/CATALOG STORE OR SERVICE CENTER/DEPARTMENT IN THE UNITED STATES.

This warranty gives you specific legal rights, and you may also have other rights which vary from state to state.

SEARS, ROEBUCK AND CO., Sears Tower, BSC 41-3, Chicago, Illinois 60684

general safety instructions for power tools

1. KNOW YOUR POWER TOOL

Read and understand the owner's manual and labels affixed to the tool. Learn its application and limitations as well as the specific potential hazards peculiar to this tool.

2. GROUND ALL TOOLS

This tool is equipped with an approved 3-conductor cord and a 3-prong grounding type plug to fit the proper grounding type receptacle. The green conductor in the cord is the grounding wire. Never connect the green wire to a live terminal.

3. KEEP GUARDS IN PLACE

—in working order, and place adjustment and alignment.

4. REMOVE ADJUSTING KEYS AND WRENCHES

Form a habit of checking to see that keys and adjusting wrenches are removed from tool before turning it on.

5. KEEP WORK AREA CLEAN

Cluttered areas and benches invite accidents. Floor must not be slippery due to wax or sawdust.

6. AVOID DANGEROUS ENVIRONMENT

Don't use power tools in damp or wet locations or expose them to rain. Keep work area well lighted. Provide adequate surrounding work space.

7. KEEP CHILDREN AWAY

All visitors should be kept a safe distance from work area.

8. MAKE WORKSHOP CHILD PROOF

—with padlocks, master switches, or by removing starter keys.

9. DON'T FORCE TOOL

It will do the job better and safer at the rate for which it was designed.

10. USE RIGHT TOOL

Don't force tool or attachment to do a job it was not designed for.

11. WEAR PROPER APPAREL

Do not wear loose clothing, gloves, neckties or jewelry (rings, wristwatches) to get caught in moving parts. NONSLIP footwear is recommended. Wear protective hair covering to contain long hair. Roll long sleeves above the elbow.

12. USE SAFETY GOGGLES (Head Protection)

Wear safety goggles (must comply with ANSI Z87.1) at all times. "Everyday eyeglasses only have impact resistant lens, they are NOT safety glasses." Also, use face or dust

mask if cutting operation is dusty, and ear protectors (plugs or muffs) during extended periods of operation.

13. SECURE WORK

Use clamps or a vise to hold work when practical. It's safer than using your hands and frees both hands to operate tool.

14. DON'T OVERREACH

Keep proper footing and balance at all times.

15. MAINTAIN TOOLS WITH CARE

Keep tools sharp and clean for best and safest performance. Follow instructions for lubricating and changing accessories.

16. DISCONNECT TOOLS

before servicing; when changing accessories such as blades, bits, cutters, etc.

17. AVOID ACCIDENTAL STARTING

Make sure switch is in "OFF" position before plugging in power cord.

18. USE RECOMMENDED ACCESSORIES

Consult the owner's manual for recommended accessories. Follow the instructions that accompany the accessories. The use of improper accessories may cause hazards.

19. NEVER STAND ON TOOL

Serious injury could occur if the tool is tipped or if the cutting tool is accidentally contacted.

Do not store materials above or near the tool such that it is necessary to stand on the tool to reach them.

20. CHECK DAMAGED PARTS

Before further use of the tool, a guard or other part that is damaged should be carefully checked to ensure that it will operate properly and perform its intended function. Check for alignment of moving parts, binding of moving parts, breakage of parts, mounting, and any other conditions that may affect its operation. A guard or other part that is damaged should be properly repaired or replaced.

21. DIRECTION OF FEED

Feed work into a blade or cutter against the direction of rotation of the blade or cutter only.

22. NEVER LEAVE TOOL RUNNING UNATTENDED

Turn power off. Don't leave tool until it comes to a complete stop.

additional safety instructions for scroll saw

Safety is a combination of operator common sense and alertness at all times when the scroll saw is being used.

WARNING: FOR YOUR OWN SAFETY, DO NOT ATTEMPT TO OPERATE YOUR SCROLL SAW UNTIL IT IS COMPLETELY ASSEMBLED AND INSTALLED ACCORDING TO THE INSTRUCTIONS...AND UNTIL YOU READ AND UNDERSTAND THE FOLLOWING:

	Page
1. General Safety Instructions for Power Tools	2
2. Assembly	6
3. Getting To Know Your Scroll Saw	12
4. Basic Scroll Saw Operation	14
5. Maintenance	16

6. Stability of Machine.

Your scroll saw must be bolted securely to stand or work bench. In addition, if there is any tendency for the scroll saw to move during certain operations, bolt your scroll saw stand or workbench to the floor.

7. Location

This scroll saw is intended for indoor use only.

8. Protection: Eyes, Hands, Face, Ears, Body

- A. To avoid being pulled into the blade:
 - 1. Roll long sleeves above elbows
 - 2. Do not wear:
 - a. Gloves
 - b. Jewelry
 - c. Ties or other loose clothing
 - 3. Tie back long hair.
- B. Do not cut pieces of material too small to hold by hand outside the blade guard.
- C. Avoid awkward hand positions where a sudden slip could cause a hand to move into the blade.
- D. To avoid slips due to lifting of the work piece make sure the blade teeth point downward toward the table.
- E. To avoid blade breakage always adjust blade tension correctly.
- F. To avoid losing control of the work piece or tool:
 - 1. When cutting a large piece of material make sure it is fully supported at table height.
 - 2. Hold the work piece firmly against the table.
 - 3. Do not feed the material too fast while cutting. Only feed the material fast enough so that the blade will cut.
 - 4. Use caution when cutting off material which is irregular in cross section which could pinch the blade before the cut is completed. A piece of molding, for

example, must lay flat on the table and not be permitted to rock while being cut.

- 5. Use caution when cutting off round material such as dowel rods, or tubing. They have a tendency to roll while being cut causing the blade to bite. Use a V-block to control the piece.
- G. When backing the blade out of the workpiece, the blade may bind in the kerf (cut)...this is usually caused by sawdust clogging up the kerf. If this happens: Turn off the scroll saw...remove plug from power source outlet...wedge open the kerf...back the blade out of the workpiece.
- H. To avoid unsupervised work, use or accidents due to inattention:
 - 1. Never leave the scroll saw work area with the power on, before the machine has come to a complete stop, or without removing and storing the switch key.
 - 2. Do not perform layout, assembly or set up work on the table while the cutting tool is in operation.
 - 3. Turn saw "OFF" and remove plug from power supply outlet before installing or removing an accessory attachment.
 - 4. Never turn your scroll saw "ON" before clearing the table of all objects: (tools, scraps of wood, etc.) except for the work piece and related feed or support devices for the operation planned.
- 9. Should any part of this scroll saw be missing, bent, or fail in any way, or any electrical component fail to perform properly, shut off power switch and remove plug from power supply outlet. Replace damaged, missing, and/or failed parts before resuming operation.
- 10. Think Safety.

Safety is a combination of operator common sense and alertness whenever the scroll saw is in operation.



The operation of any power tool can result in foreign objects being thrown into the eyes, which can result in severe eye damage. Always wear safety goggles complying with ANSI Z87.1 (shown on Package) before commencing power tool operation. Safety goggles are available at Sears retail or catalog stores.

DANGER FOR YOUR OWN SAFETY—Read and understand owner's manual before operating Scroll Saw.

1. ALWAYS wear SAFETY GOGGLES complying with ANSI Z87.1.
2. Hold workpiece down firmly.
3. Turn saw off and REMOVE SWITCH KEY before adjusting saw, changing blade, or leaving area.
4. When INSTALLING BLADE: Blade teeth must always point down. Put tension on blade by turning knob (at rear) clockwise one full turn beyond take-up of slack. Follow complete installation and checking procedure in owner's manual.

Electrical: 120-volts
60 Hz AC only, 2.0 amps



E 62443

WARNING: ALWAYS KEEP ALERT. DO NOT ALLOW FAMILIARITY (GAINED FROM FREQUENT USE OF YOUR SCROLL SAW) TO CAUSE A CARELESS MISTAKE. ALWAYS REMEMBER THAT A CARELESS FRACTION OF A SECOND IS SUFFICIENT TO INFLICT SEVERE INJURY.

motor specifications and electrical requirements

This machine is equipped with a 1725 RPM motor. It is wired for operation on 110-120 volts, 60 Hz., alternating current. For replacement motor refer to parts list in this manual.

CONNECTING TO POWER SUPPLY OUTLET

If power cord is worn or cut, or damaged in any way, have it replaced immediately.

WARNING: IF NOT PROPERLY GROUNDED THIS POWER TOOL CAN CAUSE AN ELECTRICAL SHOCK PARTICULARLY WHEN USED IN DAMP LOCATIONS CLOSE TO PLUMBING. IF AN ELECTRICAL SHOCK OCCURS THERE IS THE POTENTIAL OF A SECONDARY HAZARD SUCH AS YOUR HANDS CONTACTING THE SAW BLADE.

If you are not sure that your outlet, as pictured below, is properly grounded, have it checked by a qualified electrician.

Your unit is for use on 110-120 volts, and has a plug that looks like illustration below.

This power tool is equipped with a 3-conductor cord and grounding type plug which has a grounding prong, approved by Underwriters' Laboratories and the Canadian Standards Association. The ground conductor has a green jacket and is attached to the tool housing at one end and to the ground prong in the attachment plug at the other end.

This plug requires a mating 3-conductor grounded type outlet as shown.

WARNING: DO NOT PERMIT FINGERS TO TOUCH THE TERMINALS OF PLUGS WHEN INSTALLING OR REMOVING THE PLUG TO OR FROM THE OUTLET.

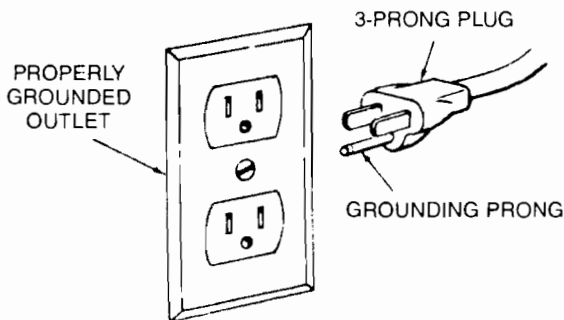

Plug power cord into a 110-120V properly grounded type outlet. If the outlet you are planning to use for this power tool is of the 2 prong type, DO NOT REMOVE OR ALTER THE GROUNDING PRONG IN ANY MANNER. Use an adapter as shown below and always connect the grounding lug to known ground.

It is recommended that you have a qualified electrician replace the TWO prong outlet with a properly grounded THREE prong outlet.

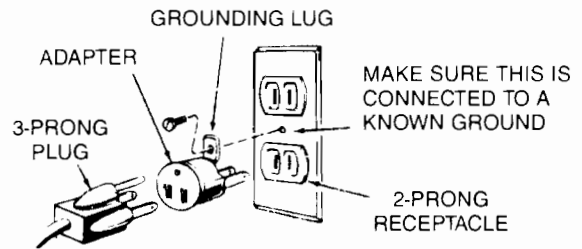

An adapter as illustrated is available for connecting plugs to 2-prong receptacles.

WARNING: THE GREEN GROUNDING LUG EXTENDING FROM THE ADAPTER MUST BE CONNECTED TO A PERMANENT GROUND SUCH AS TO A PROPERLY GROUNDED OUTLET BOX. NOT ALL OUTLET BOXES ARE PROPERLY GROUNDED.

If you are not sure that your outlet box is properly grounded, have it checked by a qualified electrician.

NOTE: The adapter illustrated is for use only if you already have a properly grounded 2-prong receptacle. Adapter is not allowed in Canada by the Canadian Electrical Code.

The use of any extension cord will cause some loss of power. Use only 3 wire extension cords which have 3-prong grounding type plugs and 3-pole receptacles which accept the tools plug.

Extension Cord Length	Wire Size A.W.G.
Up to 100 Ft.	16
100-200 Ft.	14
200-400 Ft.	10

contents

Warranty Information	2	Making Interior Cuts	13
General Safety Instructions for Power Tools . . .	2	Mounting an Auxilliary Surface for the	
Additional Safety Instruction for Scroll Saws . .	3	Work Table	14
Motor Specs and Electrical Information	4	Maintenance	15
Unpacking & Checking Contents	5	Glossary of Terms for Woodworking	16
Assembly	6	Wiring Diagram	16
Setting the Table for Horizontal or Bevel Cutting	6	Recommended Accessories	16
Aligning the Bevel Indicator	7	Trouble Shooting	17
Removing and Installing Blades	9	Repair Parts	18
Mounting the Scroll Saw	12	Service Information	20
Operation	13		

unpacking and checking contents

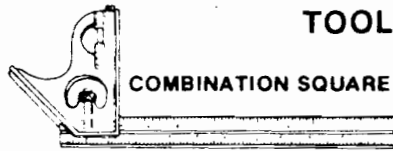

COMBINATION SQUARE



MEDIUM PHILLIPS SCREWDRIVER

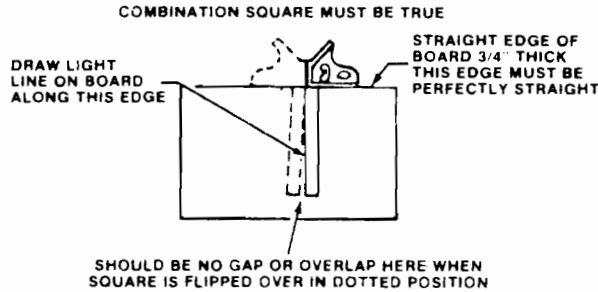

WARNING: FOR YOUR OWN SAFETY, NEVER CONNECT PLUG TO POWER SOURCE OUTLET UNTIL ALL ASSEMBLY STEPS ARE COMPLETE, AND YOU HAVE READ AND UNDERSTAND THE SAFETY AND OPERATIONAL INSTRUCTIONS.

CAUTION: NEVER LIFT THIS SAW BY THE ARM WHICH HOLDS THE BLADE OR DAMAGE WILL OCCUR TO YOUR SAW.

Separate all parts from packaging materials and check each item with illustration and "Table of Loose Parts". Make certain all items are accounted for, before discarding any packaging material.

If any parts are missing, do not attempt to assemble the Scroll Saw, plug in the power cord, or turn the switch on until the missing parts are obtained and installed correctly.

Table of Loose Parts

	Qty.
1. 16" Scroll Saw	1
2. Blade Guard	1
3. Owner's Manual	1
4. Loose Parts Bag (containing)	
Blade	1
Re-Oil Caps	4
Switch Key	1

NOTE: Hardware to mount this scroll saw to a bench or leg set is NOT supplied. See mounting instructions for recommended hardware size.

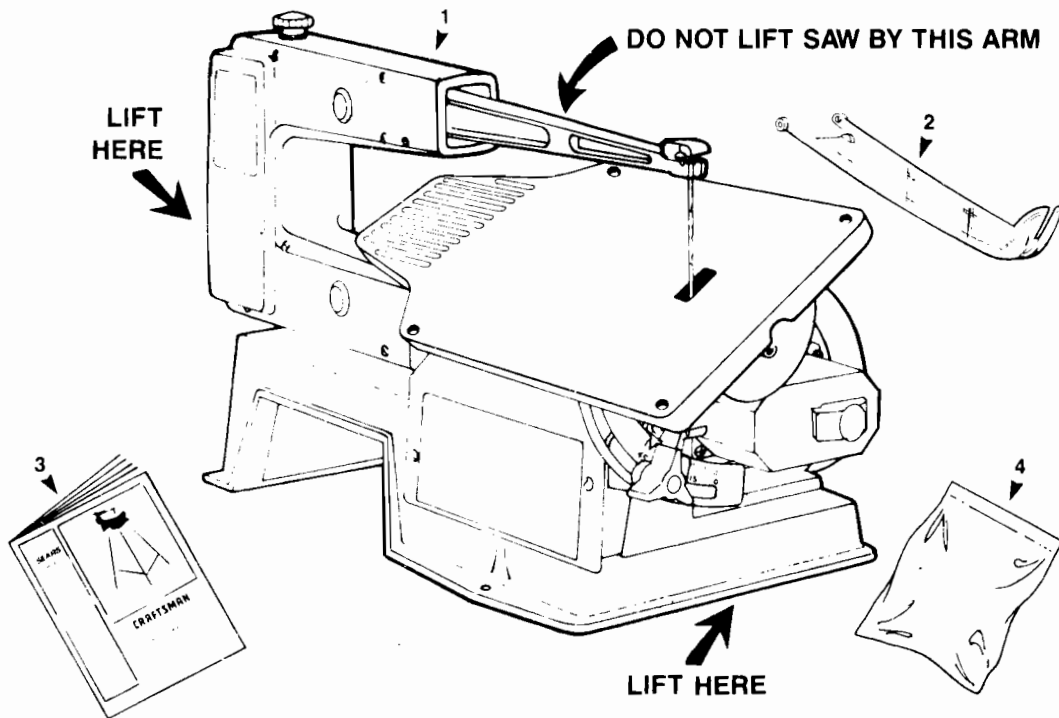

assembly

WARNING: FOR YOUR OWN SAFETY, NEVER CONNECT PLUG TO POWER SOURCE OUTLET UNTIL ALL ASSEMBLY STEPS ARE COMPLETE, AND YOU HAVE READ AND UNDERSTAND THE SAFETY AND OPERATIONAL INSTRUCTIONS.

1. Lift the saw by the frame and base and place scroll saw on work bench.
2. Familiarize yourself with the controls and features of this scroll saw indicated in the illustration.

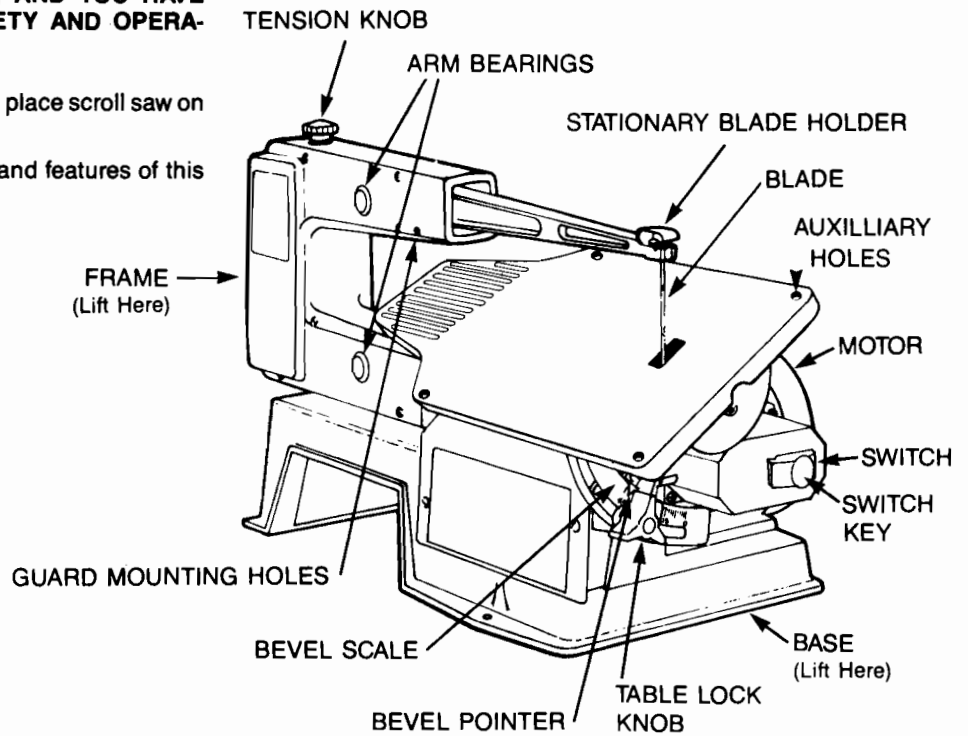

SETTING THE TABLE FOR HORIZONTAL OR BEVEL CUTTING.

1. The scroll saw work table can be tilted to the left for bevel cutting up to 45 degrees from the 0 degree or horizontal cutting position.

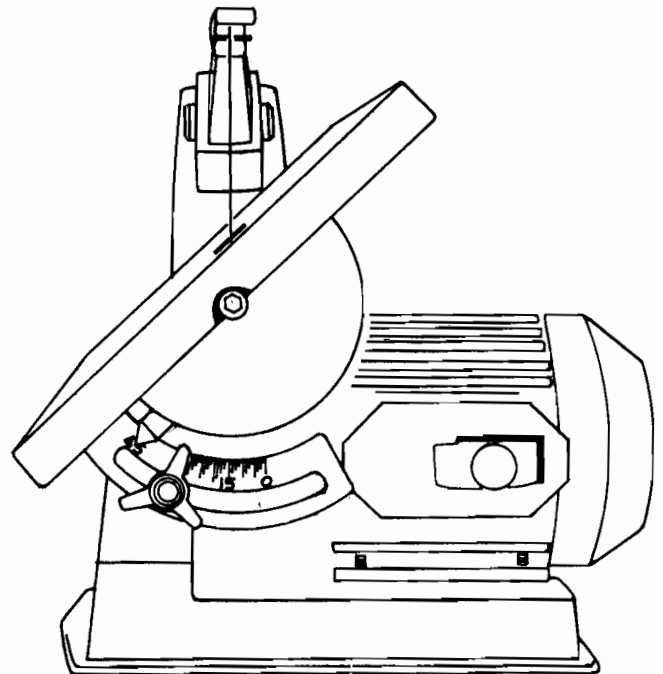

2. A bevel scale is provided under the work table as a convenient reference for setting the approximate table angle for bevel cutting.

When greater precision is required, make practice cuts and adjust the table as necessary for your requirements.

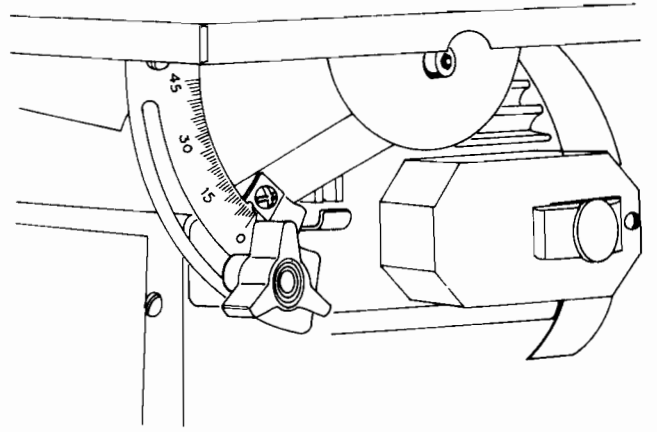

TO ALIGN THE BEVEL INDICATOR

1. Loosen the table bevel lock knob and move the table until it is approximately perpendicular, or at a right angle, to the blade.

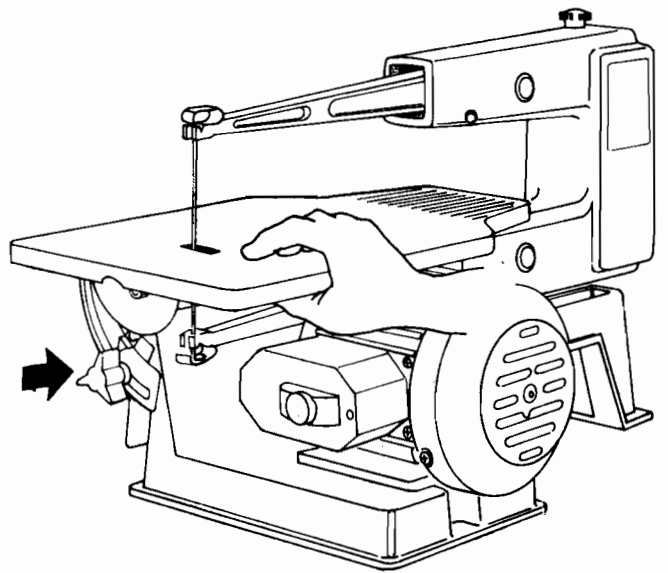

2. Use a small square to set the table at 90 degrees to the blade. If there is too much space between the square and the blade the table must be adjusted.

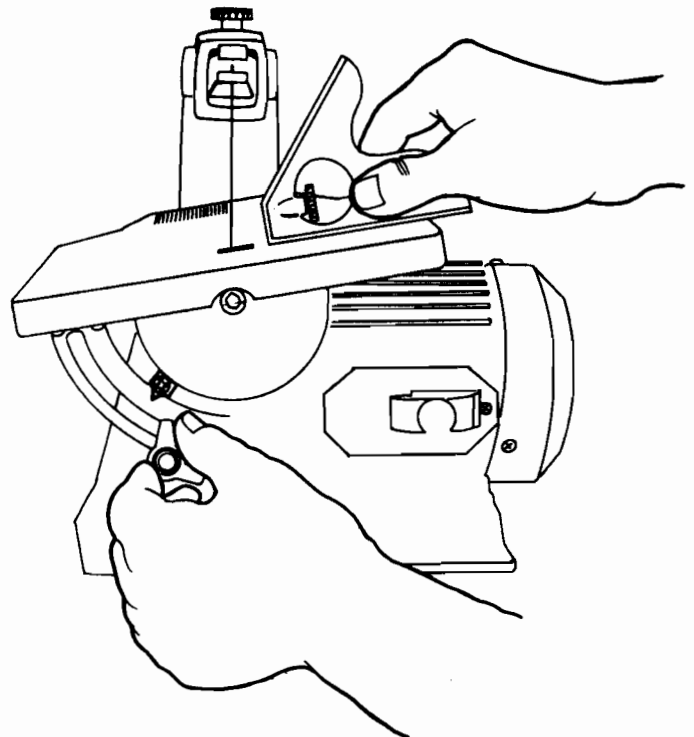

3. When the space between the square and the blade is minimal tighten the bevel lock knob.

The table should now be approximately 90 degrees to the blade.

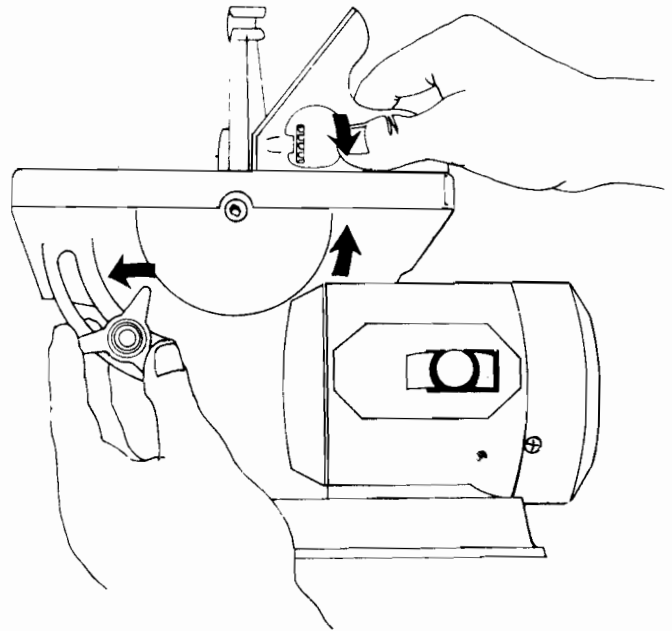

-
4. Loosen the screw holding the bevel scale pointer and adjust pointer to 0 degrees. Tighten screw.

Remember, the bevel scale is a convenient guide but should not be relied upon for precision.

Make practice cuts in scrap wood to determine if your angle settings are correct. Adjust the table as required.

NOTE: AVOID SETTING THE EDGE OF THE TABLE AGAINST TOP OF MOTOR WHICH COULD CAUSE NOISE WHEN THE SAW IS USED.

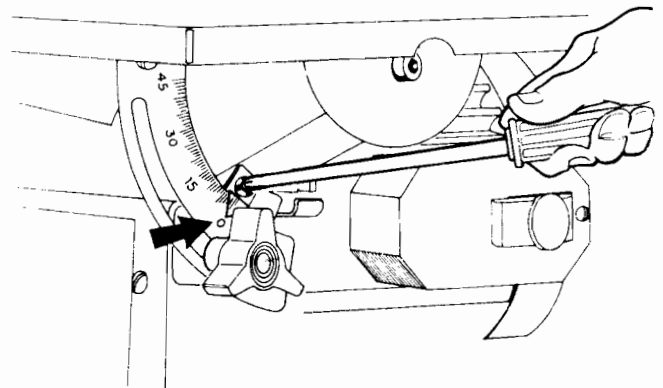

removing and installing blades

WARNING: TO AVOID INJURY FROM ACCIDENTAL STARTING, ALWAYS TURN SWITCH "OFF" AND REMOVE SWITCH KEY BEFORE REMOVING OR REPLACING THE BLADE.

- 1.. Loosen tension on blade by turning tension knob counter-clockwise  about two full turns.

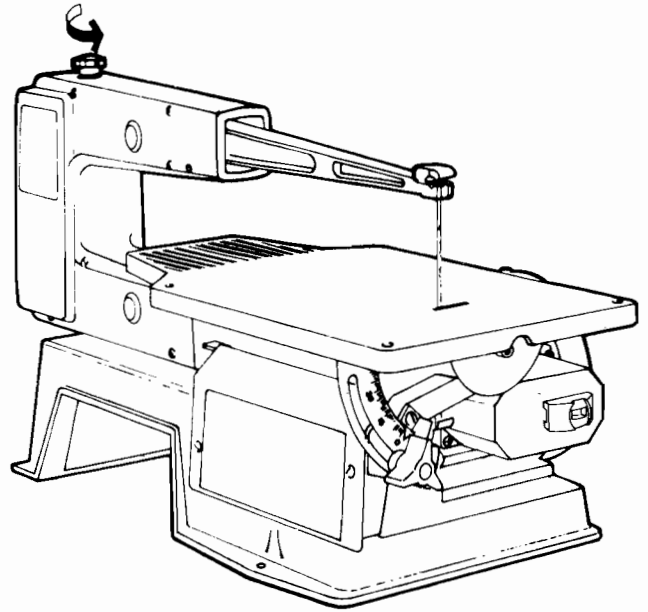

2. Remove blade by pulling forward on blade and then lifting the blade through the access hole in the table.

Slight downward pressure against the upper arm may be helpful when removing blade from upper holder.

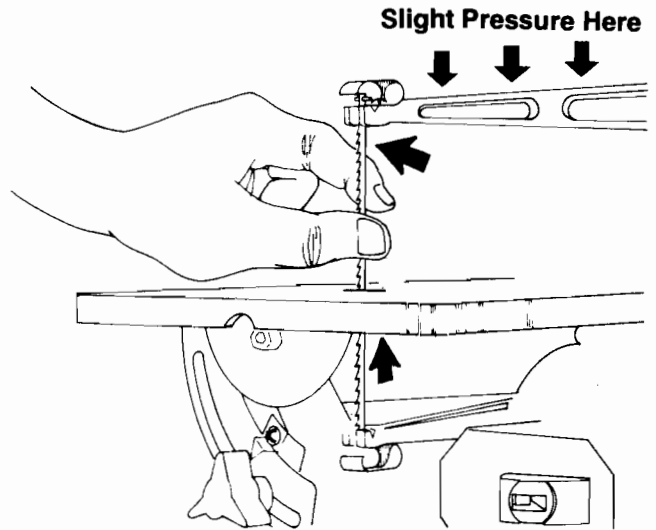

3. Look at the blade holders closely and notice the blade slots and pin recesses in the blade holder. The blade holder is made so you can position the blade for cutting from the front or one side of the saw.

Cutting from the side of the saw will be necessary when your work piece exceeds 16 inches in length. For zero degree bevel angle only.

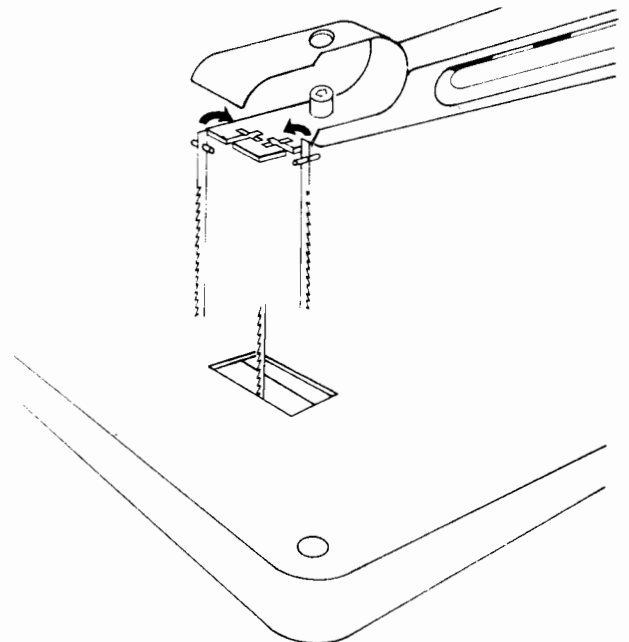

4. Locate the blade guard and carefully install it onto the saw as shown.

Lightly spread apart the blade guard so pins will go into holes in frame.

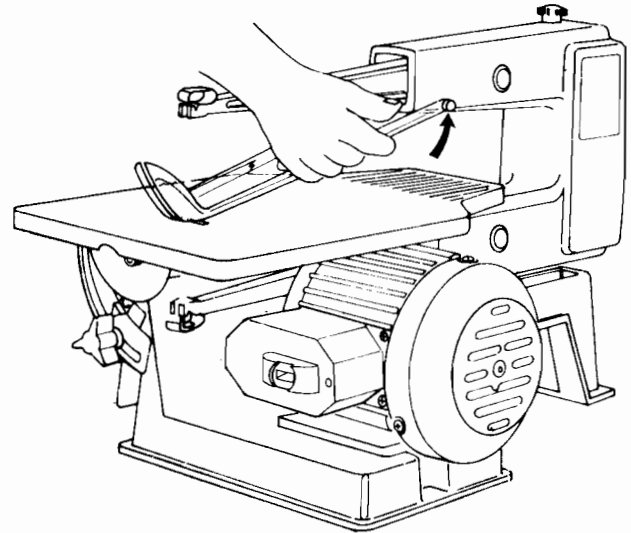

5. In order to cut, and to avoid uncontrollable lifting of the work piece, the teeth of the blades used on the scroll saw should always point downward when installed on the scroll saw.
6. Install the blade by inserting one end of the blade through the slot in the blade guard then the access hole in the table until you can hook the blade pin in the pin recess in the bottom blade holder. Slide the top blade pin into the pin recess of the top blade holder. You may need to press down lightly on the arm to install the blade.

NOTE: Use 5 inch long, pin end type blades only.

7. Carefully tighten the blade tension by turning the tension knob clockwise  just until you feel the slack in the blade is removed.

Double check to see that pins are properly located in the slots.

Then turn the tension knob an additional ONE full turn clockwise.

This amount of blade tension should do well for most cutting operations and blades.

Before applying power, use screwdriver in slot at end of motor shaft to turn mechanism while checking that the blade is properly installed.

OVERTENSIONING or UNDERTENSIONING of the blade will cause blades to break rapidly.

The thicker, harder and more abrasive the wood you are cutting the more blades you will have to use.

Blade breakage is caused by the following:

- overtension or undertension
- over working the blade by going too fast
- twisting or bending the blade
- over use—blade life exhausted
- **OVER AGGRESSIVE FEEDING** of the workpiece into the blade.

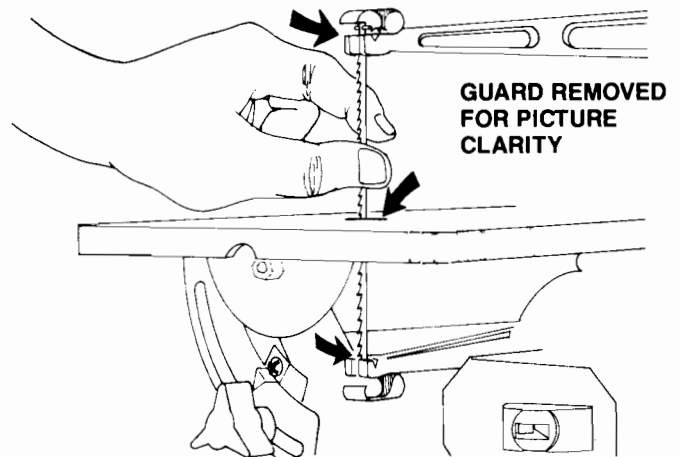

mounting the scroll saw to a bench

1. When mounting this saw to a workbench a solid wood bench is preferred over a plywood bench where noise and vibration will be more noticeable.

2. Hardware to mount this saw to a workbench is NOT supplied with the saw. However, we recommend the hardware used be no smaller than the following.

Quantity	Description
4	Hex Head Screws, 1/4"-20 x Length Required
4	Flat Washers, 9/32" I.D.
4	Lockwashers, 9/32" I.D.
8	Hex Nuts, 1/4"-20

3. A soft foam pad to place between your scroll saw and workbench is NOT supplied with the saw. However, we highly recommend the use of such a pad to reduce noise and vibration.

Quantity	Description
1	Soft foam pad such as carpet padding, 24" x 12" x 1/2"

Do NOT overtighten mounting bolts—leave some cushion in the foam pad for absorbing noise and vibration.

4. Example of mounting this scroll saw to workbench.

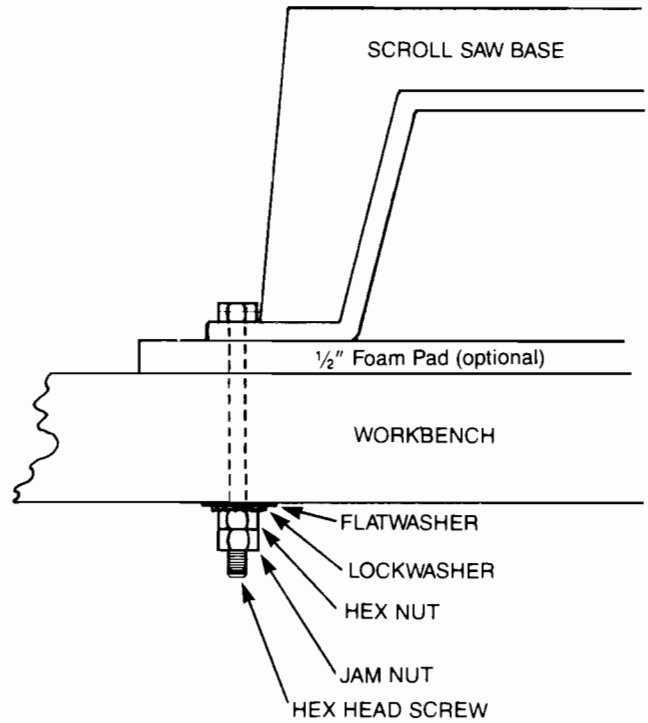

4. If you prefer to mount your saw to a leg set we recommend the leg set for bench top tools which is available through Sears Retail or Catalog Stores. The number of this leg set is 9-22244. This leg set is an optional accessory and instructions to mount the scroll saw to this leg set are included in the leg set package.

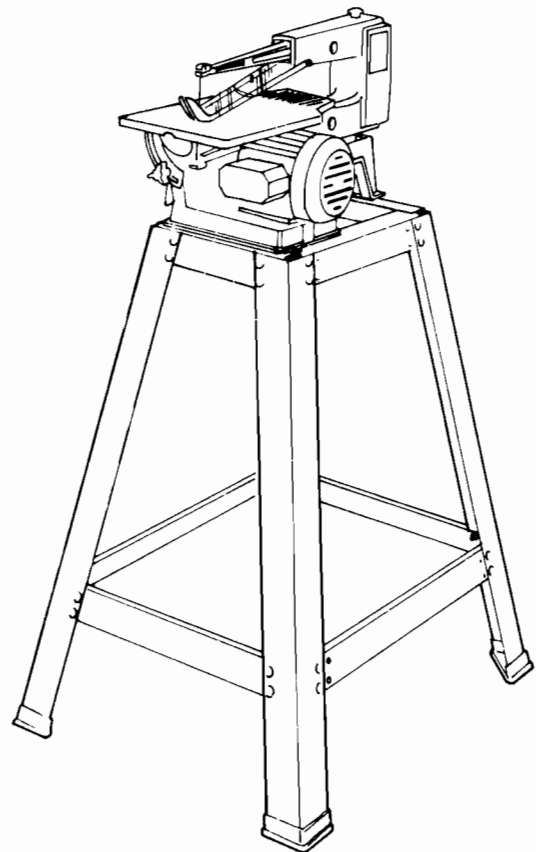

getting to know your scroll saw

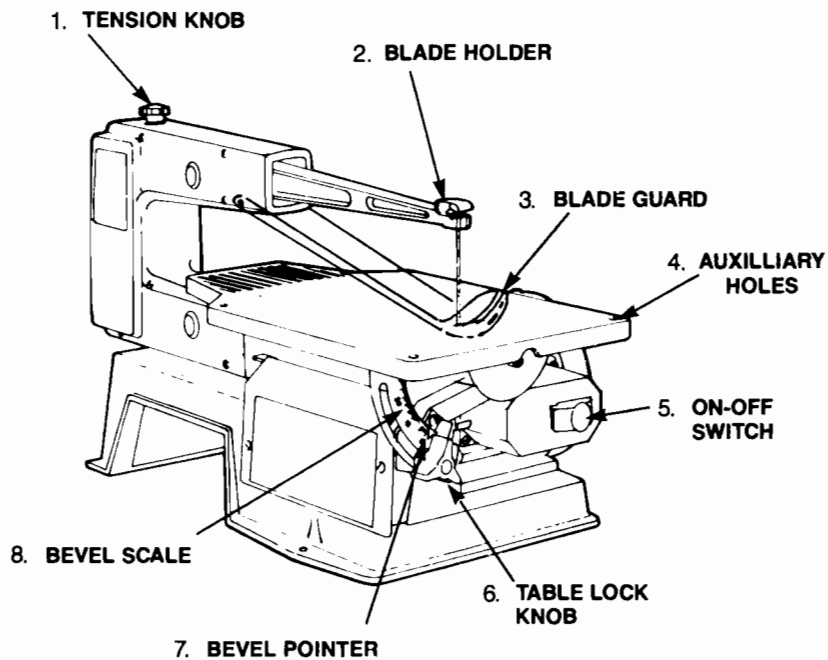

1. **TENSION KNOB**...Tightening the knob (clockwise) will increase the tension on the blade. Loosening it (counterclockwise) will decrease the tension.
2. **BLADE HOLDER**...retain and position the blade.
3. **BLADE GUARD**...Provides added control of workpiece by being directly against thickness of material. Protects hands from blade contact.
4. **AUXILLIARY HOLES**...Allows you to easily attach an auxilliary work surface to the saw table.
5. **ON-OFF SWITCH**...The On-Off Switch has a locking feature. **THIS FEATURE IS INTENDED TO PREVENT UNAUTHORIZED AND POSSIBLY HAZARDOUS USE BY CHILDREN AND OTHERS.**

A. Insert Key into switch.

NOTE: Key is made of yellow plastic.

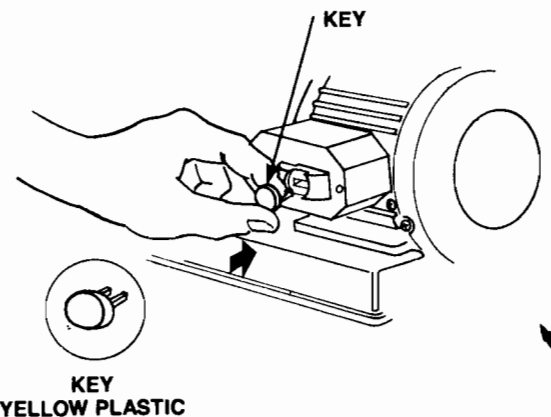

- B. To turn machine on, place finger under switch lever and pull end of switch out.

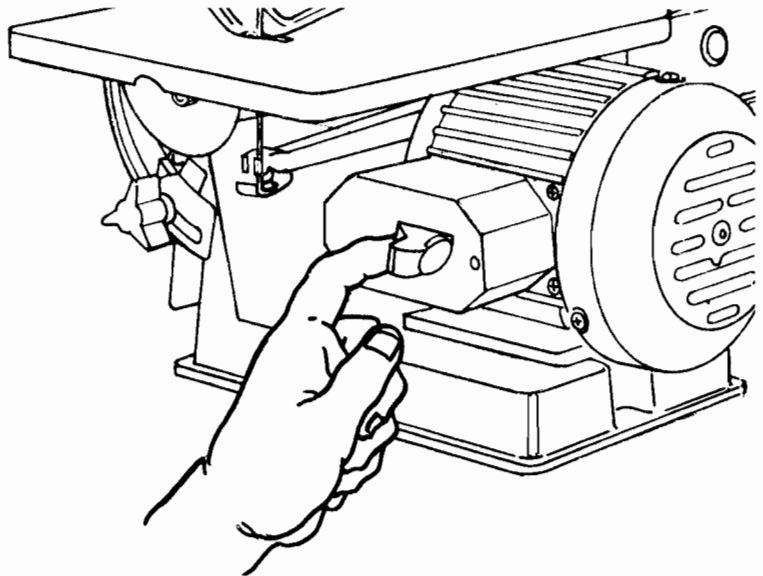

- C. To turn machine OFF...PUSH lever in.
NEVER LEAVE THE MACHINE UNATTENDED UNTIL IT HAS COME TO A COMPLETE STOP.

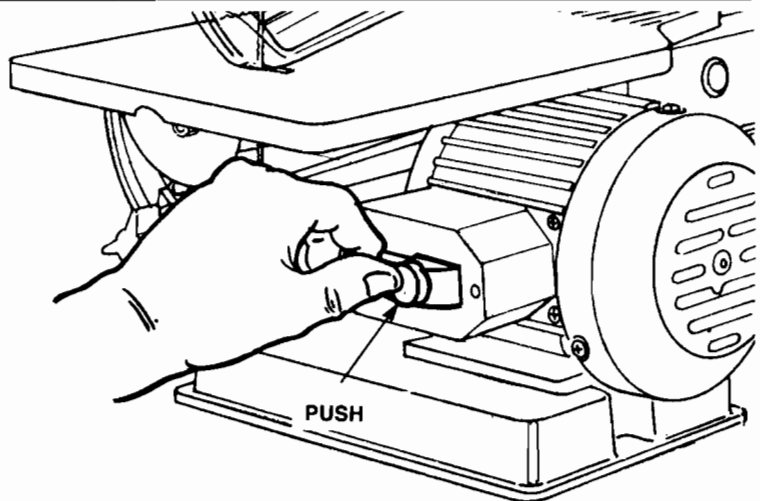

- D. To lock switch in OFF position... hold switch IN with one hand...REMOVE key with other hand.
WARNING: FOR YOUR OWN SAFETY, ALWAYS LOCK THE SWITCH "OFF" WHEN MACHINE IS NOT IN USE...REMOVE KEY AND KEEP IT IN A SAFE PLACE...ALSO...IN THE EVENT OF A POWER FAILURE (ALL OF YOUR LIGHTS GO OUT) TURN SWITCH OFF...REMOVE THE KEY AND STORE IT REMOTE FROM THE SCROLL SAW. THIS WILL PREVENT THE MACHINE FROM STARTING UP AGAIN WHEN THE POWER COMES BACK ON.

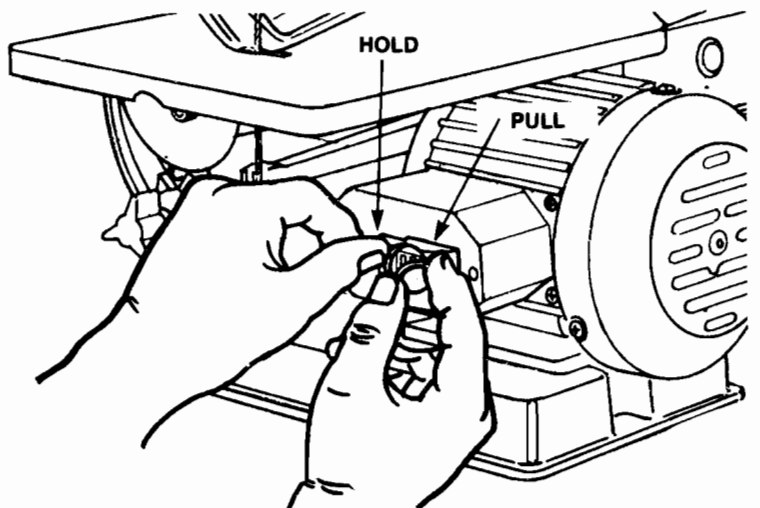

6. **TABLE LOCK KNOB**...Loosening the knob allows table to be tilted up to 45° for bevel cutting. Tightening the knob locks the table in the position you have selected.
7. **BEVEL POINTER**...Indicates what angle you have selected on the bevel scale.
8. **BEVEL SCALE**...Used to set the approximate table angle for bevel cutting.

operation of your scroll saw

PLEASE, read and understand the following items about your scroll saw before attempting to use the saw.

1. The saw does not cut wood by itself. You allow the saw to cut wood by guiding the wood into the blade as it moves.
2. The blade teeth cut wood ONLY on the down stroke.
3. You must guide the wood into the blade slowly because the teeth of the blade are very small and they can only remove wood when they are on the down stroke.
4. There is a learning curve for each person who wants to use this saw. During that period of time it is expected that some blades will break until you learn how to use the saw and receive the greatest benefit from the blades.
5. Best results are achieved when cutting wood less than one inch thick.
6. When cutting wood thicker than one inch the user must guide the wood very, very slowly into the blade and take extra care not to bend or twist the blade while cutting in order to maximize blade life.
7. Teeth on scroll saw blades wear out and as such must be replaced frequently for best cutting results. Scroll saw blades generally stay sharp for 1/2 hour to 2 hours of cutting.
8. To get accurate cuts be prepared to compensate for the blades' tendency to follow the wood grain as you are cutting.
9. This scroll saw is intended to cut wood or wood products only.
10. When choosing a blade to use with your scroll saw consider the following carefully.
 - Very fine, narrow blades should be used to scroll cut in thin wood 1/4 inch thick or less.
 - To cut wood over 1/4 inch thick use wider blades.
 - Most blade packages state the size or thickness of wood which that blade is intended to cut, and the radius, size of curve, which can be cut with that blade.
 - Wider blades can't cut curves as tight or small as thinner blades.
 - Narrower blades work well only on thinner wood material.
11. This saw uses 5 inch long, pin end type blades only. See your Sears Catalog or Retail Store for accessory blades.
12. Blades wear faster when cutting plywood, which is very abrasive; when sawing wood which is thicker than the 3/4 inch blade stroke; and when sawing hardwood, or when side pressure is placed on the blade.

MAKING INTERIOR SCROLL CUTS

1. One of the features of this saw is that it can be used to make scroll cuts on the interior of a board without breaking or cutting into the outline or perimeter of the board.

WARNING: TO AVOID INJURY FROM ACCIDENTAL STARTING, ALWAYS TURN SWITCH "OFF" AND REMOVE SWITCH KEY BEFORE REMOVING OR REPLACING THE BLADE.

2. To make interior cuts in a board remove the scroll saw blade as explained in the Assembly Section.
3. Drill a 1/4 inch hole in the board you will use to make interior cuts.
4. Place the board on the saw table with the hole in the board over the access hole in the table.
5. Install blade through hole in board and adjust blade tension.
6. When finished making the interior scroll cuts simply remove the blade from the blade holders, as described in the Assembly Section, and remove the board from the table.

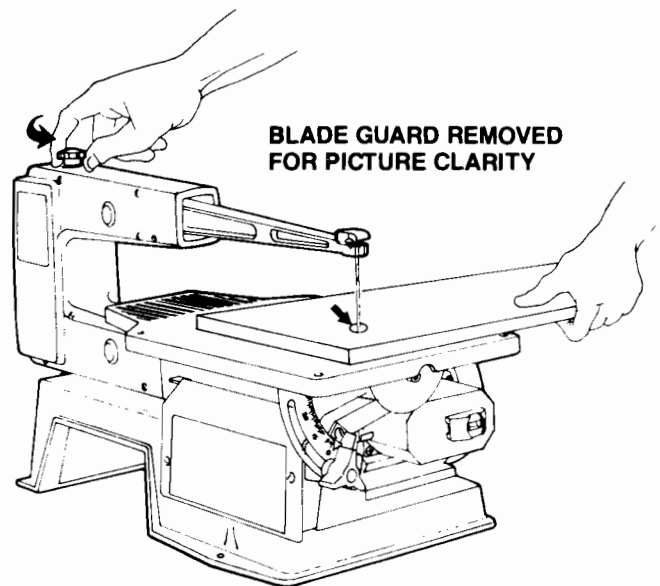

MOUNTING AN AUXILLIARY WORK TABLE

1. Four holes are provided in the work table so you can easily attach an auxilliary work surface to the saw if your needs require.
2. Mounting an auxilliary table can allow you to build a larger support area to suit your project, and could render a smoother work surface, as your needs require and an auxilliary surface can give you more support close to the blade for special cutting needs like very small or detailed projects.

EXAMPLE OF MOUNTING AN AUXILLIARY WORK SURFACE TO THE SAW TABLE

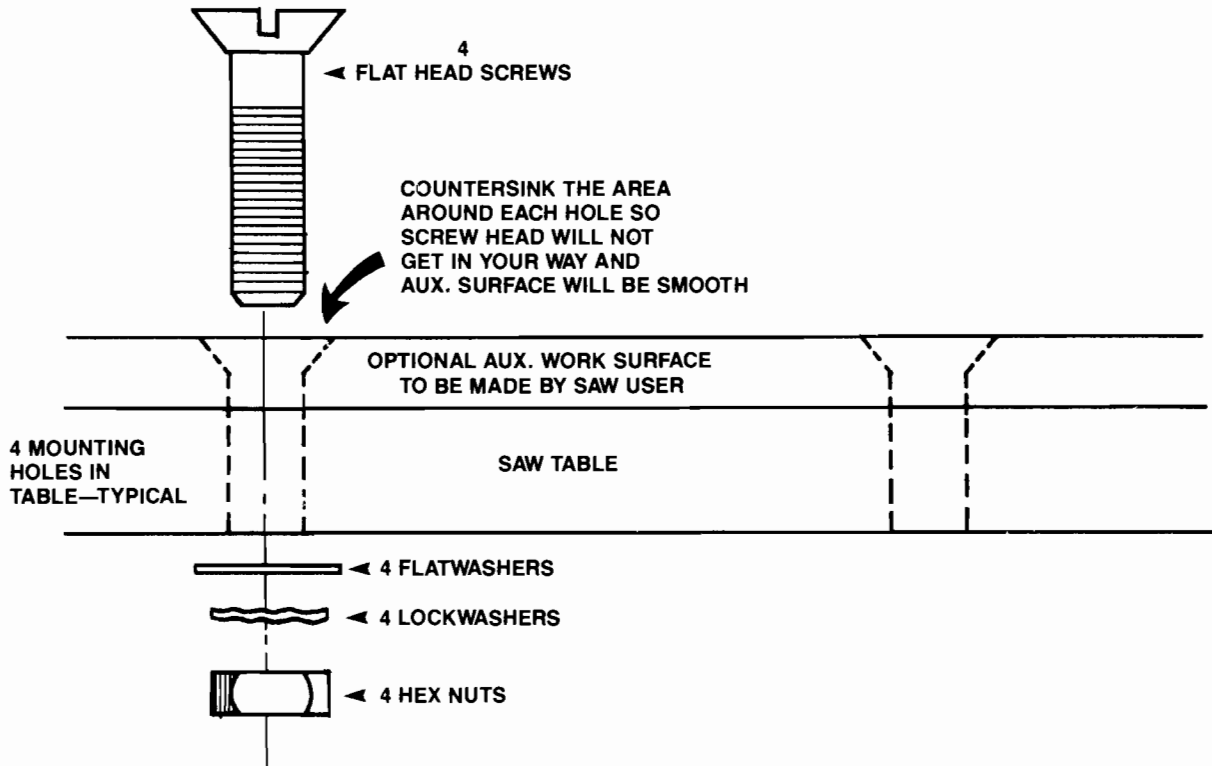

WARNING: TO AVOID TOOL TIPPING OR SUPPORT FAILURE, AUXILLIARY WORK SURFACE SHOULD NOT EXCEED 24" x 12" x 1/4"

At least an 1/4 inch hole will be needed in the auxilliary surface to insert blades.

DRILL the hole for the blade first. Then MARK location of other holes.

HARDWARE—not supplied—recommended to mount auxilliary surface to saw worktable.

Quantity	Description
4	Flat Head Screws #8-32 x 1
4	Flat Washers #8
4	Lockwashers #8
4	Hex Nuts #8-32

maintenance

WARNING: FOR YOUR OWN SAFETY, TURN SWITCH "OFF", REMOVE KEY AND REMOVE PLUG FROM POWER SOURCE OUTLET BEFORE MAINTAINING OR LUBRICATING YOUR SAW.

GENERAL

An occasional coat of paste wax on the work table will allow the wood being cut to glide smoothly across the work surface.

MOTOR

If the power cord is worn, cut, or damaged in any way, have it replaced immediately.

Do not attempt to oil the motor bearings or service the motor internal parts.

ARM BEARINGS

Lubricate the arm bearings after 10 hours of use. Re-oil after every 50 hours of use or whenever there is a squeak coming from the bearings. Four plastic bearing caps are provided with this saw. Add SAE 20 oil into each cap and then snap cap onto arm bearing. Leave caps on bearings for overnight and then remove and store caps for later use.

ALTERNATE METHOD OF OILING BEARINGS IF RE-OIL CAPS ARE LOST.

1. Turn saw on its side.
2. Squirt a generous amount of SAE 20 oil around the shaft end and bronze bearing.
3. Let the oil soak in overnight in this condition.
4. Next day repeat the above procedure for the opposite side of the saw.

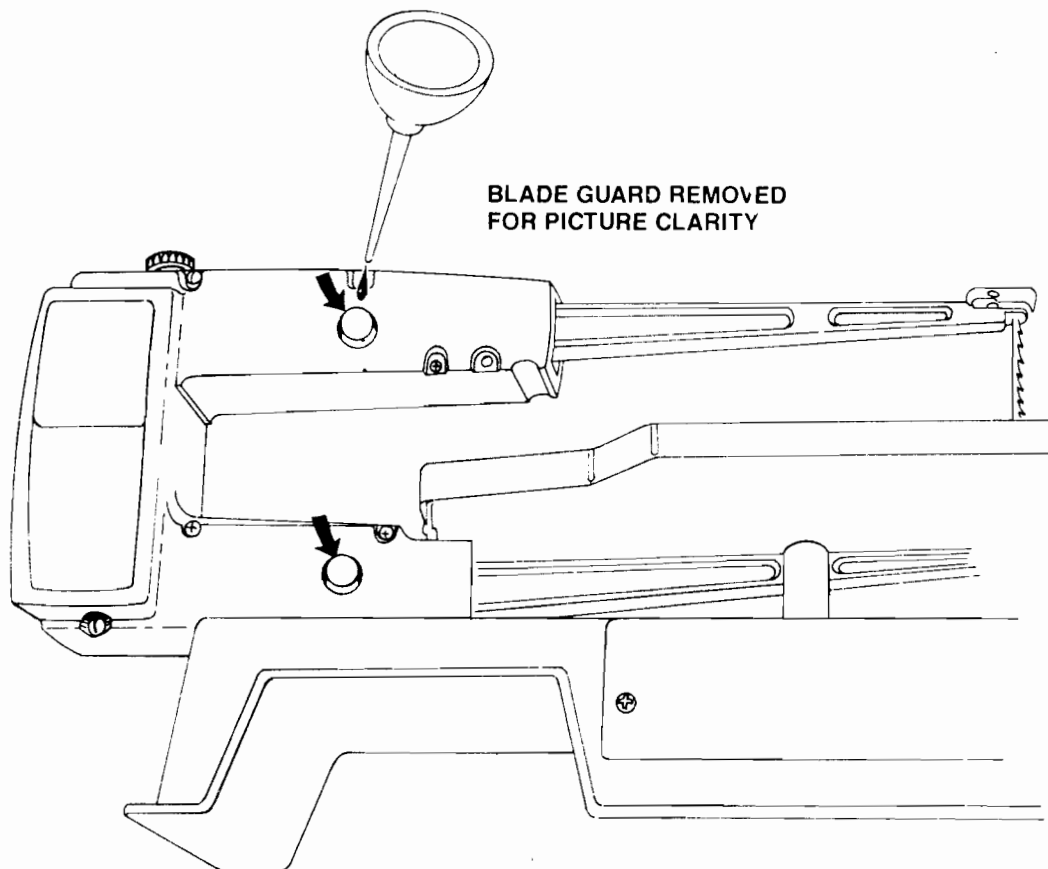

wiring diagram

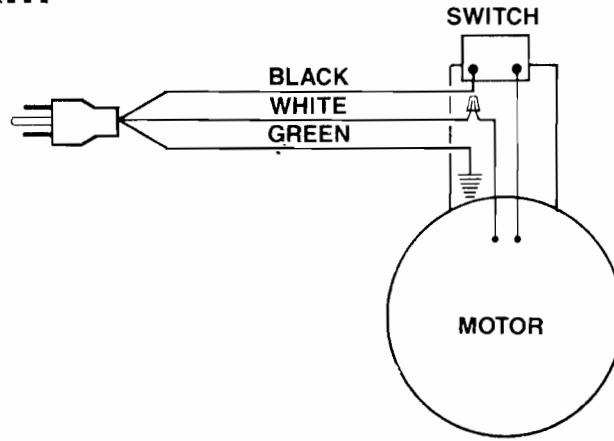

recommended accessories

Item	Sears Number
Leg Set	9-22244
Blades	See Catalog—For 5" long, pin end type blades
	9-26873—medium radius cuts in wood up to 1½" thick
	9-26879—fine radius cuts in wood up to ¼" thick

The above recommended accessories are current and were available at the time this manual was printed.

glossary of terms for woodworking

- Kerf**—the slot cut by the blade
- Leading Edge**—the edge of the work piece which is pushed into the blade first.
- Sawblade Path**—The area of the workpiece directly in line with and moving toward the sawblade edge.
- Blade Tooth Set**—the distance that the edge of the sawblade tooth is bent (on set) outward from the side of the blade.
- Trailing Edge**—the workpiece edge last cut by the sawblade.
- Work Piece**—the item on which the cutting operation is being performed.

trouble shooting

WARNING: FOR YOUR OWN SAFETY, TURN SWITCH "OFF", REMOVE KEY AND REMOVE PLUG FROM POWER SOURCE OUTLET BEFORE TROUBLESHOOTING YOUR SCROLL SAW.

PROBLEM	PROBABLE CAUSE	REMEDY SUGGESTED
Breaking Blades.	<ol style="list-style-type: none"> Wrong tension. Over working blade. Wrong blade application. Twisting blade in wood. 	<ol style="list-style-type: none"> Adjust blade tension. Reduce feed rate. Use narrow blades for cutting thin wood, wide blades for thicker wood. Avoid side pressure on blade.
Motor will not run.	<ol style="list-style-type: none"> Defective cord or plug. Defective motor. 	<ol style="list-style-type: none"> Replace defective parts before using saw again. Consult Sears Service. Any attempt to repair this motor may create a HAZARD unless repair is done by a qualified service technician. Repair service is available at your nearest Sears Store.
Vibration NOTE: There will always be some vibration present when the saw is running because of the motor operation.	<ol style="list-style-type: none"> Improper mounting of saw. Unsuitable mounting surface. Loose table or table resting against motor. Loose motor mounting 	<ol style="list-style-type: none"> See mounting instructions in this manual for proper mounting technique. The heavier your work bench is the less vibration will occur. A plywood workbench will not be as good a work surface as the same size solid lumber. Use common sense in choosing a mounting surface. Tighten table lock knob. Tighten motor mounting screws.
Blade Runout—Blade not in-line with arm motion	Blade holders not aligned	<ol style="list-style-type: none"> Loosen cap screws holding blade holders to arms. Adjust position of blade holders—Retighten holders.

**PARTS LIST FOR CRAFTSMAN 16-INCH MOTORIZED SCROLL SAW
MODEL NO. 113.236110**

Always order by Part Number—Not by Key Number

Key No.	Part No.	Description
1	66055	Motor (includes Switch & Cord)
2	66066	Housing Asm, (Includes Key No. 48)
3	STD 522507	*Hex, Head Screw 1/4-20 x 3/4
4	STD 551125	*Lockwasher 1/4
5	66047	Coupling, Eccentric
6	STD 503103	*Screw, Set 5/16-18 x 5/16
7	STD 510602	*Screw Pan Cross 6-32 x 1/4
8	60256	Key Switch
9	62442	Switch, Locking
10	66049	Guard Blade
11	66056	Cord With Plug
12	66070	*Screw, Hex, Soc. Cap #8-32 x 3/8
13	STD 551208	*Lockwasher, External No. 8
14	66050	Holder, Upper Blade
15		†Blade
16	66067	Arm, Upper
17	66065	Table
18	431957	*Screw, Hex Soc. Cap 1/4-20 x 1-5/8
19	66058	Spring, Anti-Rattle
20	STD 541025	*Nut, Hex 1/4 x 20
21	66064	Support Table
22	66044	Bracket, Tilt
23	STD 601103	*Screw, Pan Cross Type "T" 10-32 x 3/8
24	66052	Indicator, Tilt
25	66053	Knob
26	STD 551025	*Washer 17/64 x 1/2 x 1/32
27	STD 551131	*Lockwasher 5/16

Key No.	Part No.	Description
28	STD 523107	Screw, Hex Hd. 5/16 - 18 x 7/8
29	66063	Spring, Compression
30	193250	*Screw, Hex Soc. Cap 10-32 x 7/8
31	66069	Washer
32	66060	Spacer, Bearing
33	66051	Holder, Lower Blade
34	66045	Bushing
35	66054	Link Arm
36	STD 551110	*Lockwasher No. 10
37	STD 541110	*Nut Hex 10-32
38	60116	*Screw, Hex Soc. Cap 10-32 x 3/4
39	66071	*Screw, Pan Cross Type "T" 8-32 x 1-1/8
40	66046	Cap, Re-Oil
41	66072	*Screw, Pan Cross Type "T" 8-32 x 1-3/8
42	STD 511103	*Screw Pan Cross 10-32 x 3/8
43	66057	Plate, Cover
44	66040	Base
45	STD 532510	*Bolt, Carriage 1/4" x 20 x 1
46	STD 551108	*Lockwasher No. 8
47	66059	Retainer
48	66041	Bearing, Flanged
49	66068	Arm, Lower
50	66061	Spring
51	66042	Knob Asm. Tension
52	66062	Retainer, Bolt
53	66043	Bumper
	66048	Owners Manual (not illustrated)
54	STD 512505	*Screw Pan Cross 1/4-20 x 1/2

* Standard hardware items—may be purchased locally.

† Stock Item—May be secured through the Hardware Dept. of most Sears Retail Stores or Catalog Order Houses.

**PARTS LIST FOR CRAFTSMAN 16-INCH MOTORIZED SCROLL SAW
MODEL NO. 113.236110**

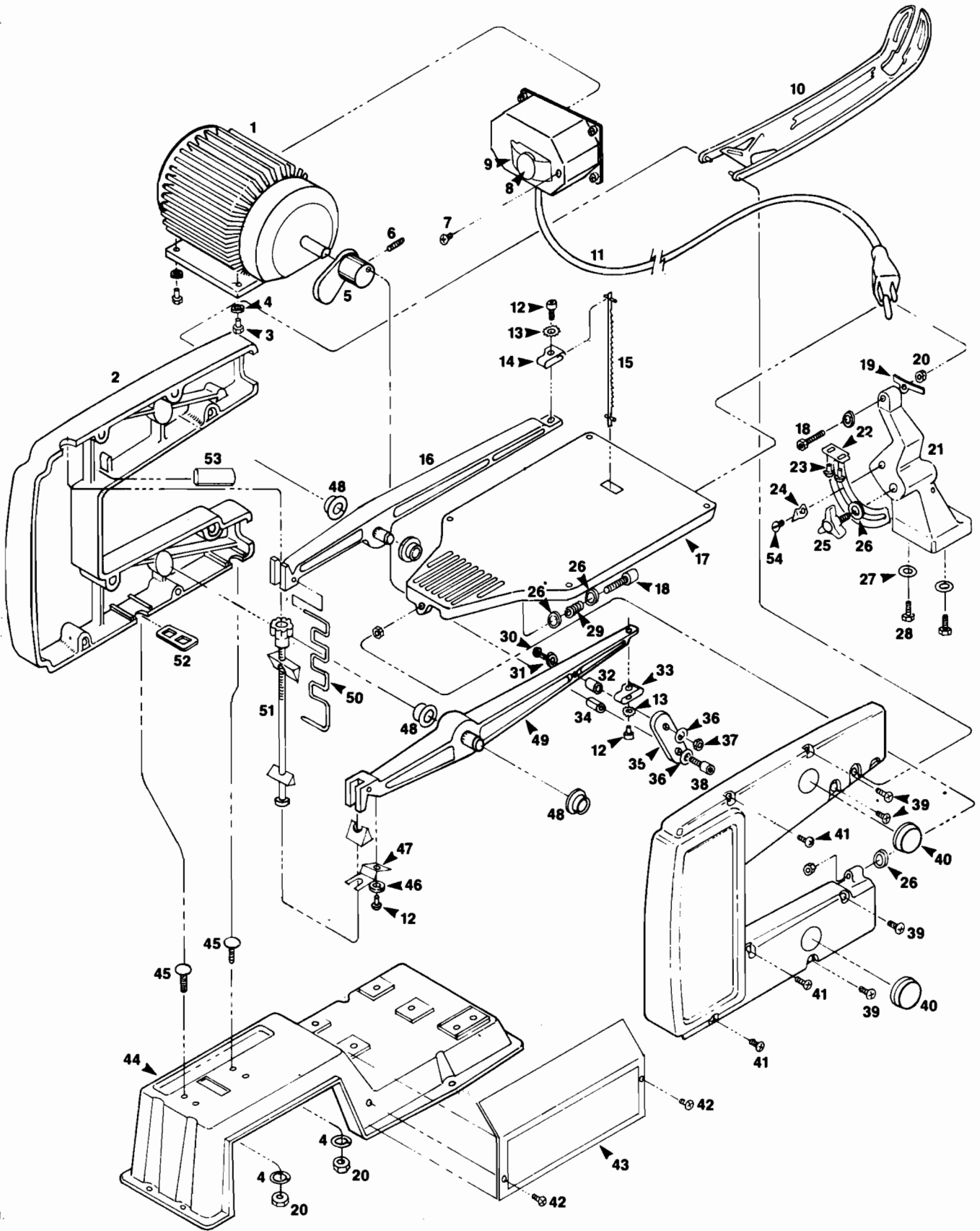

SEARS

owners manual

SERVICE

MODEL NO. 113.236110 SCROLL SAW

HOW TO ORDER REPAIR PARTS

16 INCH SCROLL SAW

Now that you have purchased your Scroll Saw should a need ever exist for repair parts or service, simply contact any Sears Service Center and most Sears, Roebuck and Co. stores. Be sure to provide all pertinent facts when you call or visit.

The model number of your Scroll Saw will be found attached to the underside of the worktable.

WHEN ORDERING REPAIR PARTS, ALWAYS GIVE THE FOLLOWING INFORMATION:

PART NUMBER	PART DESCRIPTION
MODEL NUMBER 113.236110	NAME OF ITEM 16 inch Scroll Saw

5/11 800 1 N 6425

All parts listed may be ordered from any Sears Service Center and most Sears stores. If the parts you need are not stocked locally, your order will be electronically transmitted to a Sears Repair Parts Distribution Center for handling.

Sold by SEARS, ROEBUCK AND CO., Chicago, IL 60684 U.S.A.