



Sears

1972

CRAFTSMAN®

POWER AND HAND TOOL CATALOG

CABINET AND BUILDERS' HARDWARE
PLUS AUTOMOTIVE TOOLS

This Saw described
on page 3

You can equip your entire workshop
with the hand and power tools
and accessories in this catalog

INDEX ON PAGE 118

Prices in effect until
December 31, 1972

Sears, Roebuck and Co.
*Satisfaction Guaranteed
or Your Money Back*

CRAFTSMAN® 12-inch Tilting Arbor



**Sears Has a Credit Plan
to Suit Your Needs**
See Big Book or ask for details

floor model Saw Outfit

with electro-mechanical brake that stops saw blade automatically



Compound cut. Saw at bevel angle and a miter angle for making tapered forms

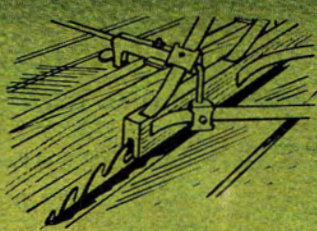

Edge cutting. Cut groove on narrow work edges; use hold down set for accuracy



Metal cuts made with cut-off wheel. Also cuts concrete, plastic, brick or glass



Cove cut. With proper blade, use to shape cove mouldings of various designs and sizes

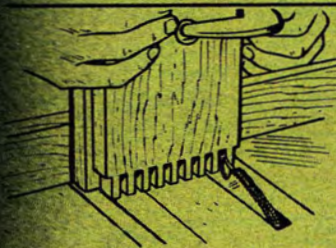

Dado and groove cuts. Make precision dado, ploughing, lap, joint or rabbet cuts

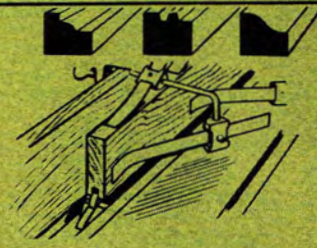

Moulding cutter. Mount moulding head in place of saw blade; shape various designs



Rip. Fast accurate ripping through center of a panel over 6 feet wide



Sanding. For that "finishing touch," just replace saw blade with sanding plate



EXACT-I-CUT . . . exclusive up-front aligning device that indicates and aligns cut exactly to blade

- 3450 rpm direct drive capacitor start motor . . . develops 4½ HP on 220-240 volts
- Outfit includes saw, motor, support legs and 3 extensions
- Exclusive work-guide panel makes fast work set-ups easy
- Micro-adjustment knob positions rip fence
- Extra-large 57x27-inch work area (fully extended)

Complete Outfit **\$369⁰⁰**

Heavy-duty cast iron construction. Extra power and capacity for most big production and/or commercial applications. Extra large work area (57x27 inches extended). Two 10-inch solid type extensions and one adjustable extension with extra rip fence . . . let you make accurate cuts to center of a 76-inch work piece; lower extra rip fence and there's almost no limit to size of work that can be handled. Rip fence locks front and rear . . . exactly to desired line of cut.

Solid extensions provide no openings to catch small work. All controls in front for operating speed and ease. Cuts through wood up to 3¾ inches thick. 13½ inches from blade to front of table at maximum cutting depth. Rip fence aligns itself to blade with single lock handle.

With 4 rugged angle steel legs—no stand required. Includes built-in sawdust collector for use with HOME-N-SHOP Vac; also 12-in. Kromedge® combination blade (¾-in. center hole); see-through plastic blade guard with splitter, anti-kickback pawls. Miter gauge; positive stops at 0° and 45°.

Direct-drive motor, sealed ball bearings. 8-ft. 3-wire cord; adapter. 220-240-volt, 60-c. AC (factory wired for 240-volt). UL listed. *One year guarantee* (see page 8).
9 KT 2993N—Shpg. wt. 240 lbs. \$369.00

Inserts for 1 2-inch saw (9 KT 2993N) described above. Shpg. wt. 1 lb. 10 oz.
9 KT 29935—Dado Insert. \$4.99
9 KT 29936—Molding Head Insert 4.99

SPECIFICATIONS

- Depth of cut (maximum) 3¾ in.
- Depth of cut at 45° (maximum) 2½ inches
- Blade type—Kromedge® combination
- Blade size—12-in. diameter (¾-inch center hole)
- Blade speed—3450 rpm; approximately 10,800 peripheral feet per minute
- Blade tilt. 45 degrees, left
- Distance in front of blade—(at full depth) 13½ inches (at 1-inch depth) 16¼ in.
- Table size—20 inches wide, 27 inches long
- Base size—18 inches wide, 19¾ inches long
- Working height. 35 inches
- Over-all width. 57 inches (extended)
- Over-all length. Measures 37¼ inches
- Length of fence—33½ inches (30-inch work face)
- Dado capacity (using 8-inch dado set) . . . 1 inch wide, 1¼ inches deep

Bench saw Attachments and Accessories

1 CRAFTSMAN® Miter Gauge. Adjustable with stops at 45° and 90°. Bar slide for most saws with ¾x½ in. miter slot. Fits above and saws on pages 2, 4, 5 (except 9 KT 2421C) and most former bench saws. Will also fit Disc Sander 9 KT 2254L; Shaper 9 KT 2394N, Band Saw 9-2429. 9 KT 29929—Shpg. wt. 4 lbs. 5 oz. . . \$11.99

2 Miter Gauge Stop Rods. For use with Miter Gauge (1) above as well as with former 9-29925C. 9 KT 29924—Shpg. wt. 1 lb. 4 oz. . . . \$2.99

3 Hold-down Clamp. For Miter Gauge (1) above. Automatic release. 9 KT 29928—Shpg. wt. 2 lbs. 5 oz. . . \$8.99

4 CRAFTSMAN Hold-down Set. Designed for use with bench saws, radial-arm saws, shapers and jointer-planers. With four steel fingers, two clamps and two L-rods. Shipping weight 2 lbs. 11 oz. 9 KT 3230. Set \$5.99

5 Taper Jig. Designed for cutting tapers on bench or radial saws. Made of extruded aluminum. Includes locking bracket, handle and metal scale that designates degrees of taper as well as inches. Cuts to 3 inches per foot (15°). Shipping weight 2 lbs. 3 oz. 9 KT 3233. \$5.99

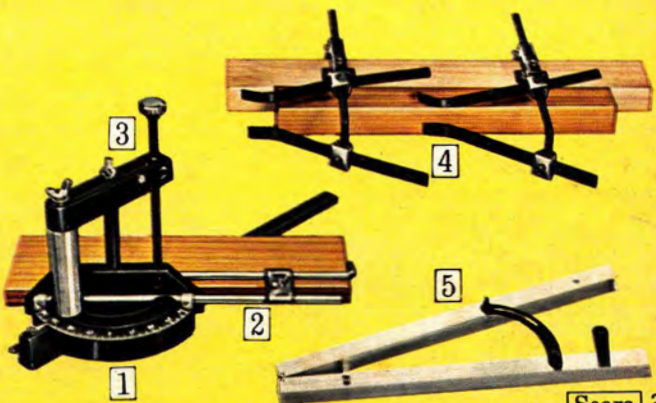



CRAFTSMAN® 10-inch Bench Saw

- Exact-I-Cut aligns cut exactly to blade
- Up front push-pull, on-off switch . . . key locks
- Convenient color-coded controls . . . give you fast set-ups and adjustments.

Without motor, extensions or floor base **\$189⁰⁰**

In addition to sculptured styling, you also enjoy the convenience of pre-tensioned controls to hold depth, angle settings . . . no readjusting for repeated cuts. Bevel handle can be mounted on left or right side. Belt guard encloses belt, motor pulley behind saw. Maximum depth of cut 3 3/4 in. Motor, blade, belt tilt together to eliminate belt twisting for positive power transmission. Motor mount floats . . . belt stays tight.

Pick-off rip fence removes at any point. One lever locks fence against table (not guide bar) for extra accuracy. A twist of the micro-adjustment knob adjusts rip fence to desired cut. Permanently lubricated sealed ball bearings. 10-inch Kromedge® chisel-tooth blade

with 5/8-inch center hole. Extra large work area measures 20 in. wide x 27 in. deep. See-through blade guard made of tough plastic (including splitter and anti-kickback pawls), aluminum miter gauge, motor mount, machine and motor pulleys and V-belt. 1-year guarantee . . . p. 8. 9 KT 2994N—Wt. 150 lbs. \$189.00

Above saw with CRAFTSMAN 1-HP Motor (9 KT 1217C, page 30), 3450-rpm, sleeve-bearing, capacitor-type. 110-120-volt, 60-c. AC., 4-ft. 3-wire cord. Shipping weight 176 lbs. 9 KT 13433N2 \$214.95

1 Rugged steel Floor Base for above saw (9 KT 2994N) only. Sides and top 18-ga. steel for extra rigidity and accuracy. Feet with rubber pads. 22x23 3/4 in. at bottom. Height adjusts 21 to 23 1/2 in. Unassembled. 9 KT 2227C—Shipping weight 29 pounds. \$29.99

2 10-inch solid-type Table Extension. No openings for material to lodge in. Mounts on either side. Incl. bolts, rip fence rack extension. Also fits 9-29911N. 9 KT 29925C—Shpg. wt. 11 lbs. . . . \$19.99

Extension Fence Conversion Kit (not shown). For using solid extensions on former Models 113, 2990, 29901, 29902. Shipping weight 1 pound. 9 KT 29923 \$1.99



A mere twist of the micro adjustment knob adjusts rip fence exactly to desired cut. Never needs trial run. With push-pull safety switch and key lock.

CRAFTSMAN® 10-inch Bench Saw

Without motor **\$159⁰⁰**

Motor, blade and belt tilt together. Cuts through wood up to 3 3/4 in. thick. Handy 20x27-in. work area. Pre-tensioned controls hold depth and angle settings—no readjusting for repeated cuts. Rip fence locks at front and rear simultaneously . . . stays rigid. Measures 13 in. from blade to front of table at maximum depth of cut. Positive tilt stops at 45°, 90°. Fine Acme threads for extra precision in adjustment.

Pick-off rip fence removes at any point. One lever locks fence against table (not guide bar) for extra accuracy. Sealed ball bearings.

3 20-inch Adjustable Table Extension. 9 KT 2178—Shpg. wt. 12 lbs. . . . \$19.99

Steel Floor Base for 8-inch and 10-inch bench saws (not for 9 KT 2294N). Not shown. Slides and top of 18-ga. steel. Rails and feet 14-ga.; feet with rubber pads. 19 1/4 x 24 1/2 in. at bottom. Height adjusts 23 1/4 to 26 1/2 in. Unassembled. 9 KT 2226C—Shpg. wt. 27 lbs. \$27.99

ings. 10-inch Kromedge® blade (5/8-in. center hole). See-through plastic blade guard (incl. spreader and anti-kickback pawls), aluminum miter gauge, motor mount, machine, motor pulleys and V-belt. No motor, extensions, stop-rods, hold-down or base. One-year guarantee—p. 8. 9 KT 29911N—Wt. 139 lbs. \$159.00

Above saw with 1-HP Motor (9KT1217C—p. 30). 3450 rpm sleeve-bearing, capacitor-type. 110-120-v., 60-c. AC. Four-foot cord. *Separate prices total \$208.99. Save \$19.99.* 9 KT 13401N2—Wt. 165 lbs. \$189.00

Molding Head and Dado Inserts. Use for a variety of jobs—plough, dado, lap, groove, joint and rabbet. Use with most CRAFTSMAN 10-inch bench saws. Set screw leveling adjustment. Shipping weight 1 lb.

Dado Insert
9 KT 29958 \$4.99
Molding Head Insert
9 KT 29959 4.99

SPECIFICATIONS for both 10-inch Saws

	9 KT 2994N	9 KT 29911N
Depth of cut (maximum)	3 3/4 inches	3 3/4 inches
Blade type—Kromedge® combination	chisel-tooth, free-cut	taper-ground, free-cut
Blade size (5/8-inch center hole)	10-in. diam.	10-in. diam.
Blade speed (approx. peripheral feet per min.)	9,000	9,000
Blade tilt	45°	45°
Distance in front of blade at full depth	13 in.	13 in.
Distance in front of blade at 1 in. depth	15 1/2 in.	15 1/2 in.
Table size (width x length)	20x27 in.	20x27 in.
Base size (width x length)	20x23 in.	15 1/4 x 19 1/8 in.
Over-all height x width x length	19 1/4 x 24 x 37 in.	15 x 23 1/4 x 28 in.
Length of fence (32 1/2 in. work face)	30 in.	34 in.
Dado capacity (using 7-in. dado set)	1 3/8-in. wide, x 1 3/8-in. deep	1 3/8-in. wide, x 1 3/8-in. deep
Motor pulley (included)	2 1/2 in.	2 1/2 in.
Machine pulley (included)	2 1/2 in.	2 1/2 in.
V-belt (included—length x width)	41 x 1/2 in.	41 x 1/2 in.

CRAFTSMAN® 8-inch Tilting-arbor Bench Saw

Cuts through wood up to 2½ inches thick . . large 17x20-inch table area provides ample work space



On-off Switch



Without motor, base or extensions **\$109⁰⁰**

SPECIFICATIONS

- Depth of cut (maximum) 2½ inches
- Blade type . . Kromedge® chisel-tooth combination
- Blade size . . 8-in. diameter (½-inch center hole)
- Blade speed . . 9000-10,000 peripheral ft. per min.
- Distance in front of blade (at full depth) 10¼ in. (at 1-in. depth) 12¼ in.
- Table size . . 17 inches wide, 20 inches long
- Base size . . 15 inches wide, 17½ inches long
- Over-all height . . . 11½ in.
- Over-all length . . . 22 in.
- Over-all width . . . 20½ in.
- Length of fence . . . 25 in. (23-inch work face)
- Dado capacity (using 6-in. dado set) . . 1½ in. wide, 1¾ in. deep
- Motor pulley (incl.) 2½ in.
- Machine pulley (incl.) 2 in.
- V-belt (included) ¾x29 in.

Meets demand for a truly fine bench saw at moderate price. Separate tilt and depth controls. Accurate tilt indicator. Rip fence aligns automatically to blade with single lock handle. Pick-off type fence can be removed at any point. Motor rides horizontally on self-aligning motor mount . . no need to lift motor when blade is tilted. With blade guard, rip fence, miter gauge, machine and motor pulleys, V-belt. Use minimum of ¾-HP 3450-rpm motor. Guaranteed for 1-year . . see page 8.

9 KT 24282N—Shipping weight 80 pounds \$109.00

Saw above with CRAFTSMAN ¾-HP capacitor-start motor, 3450 rpm (9KT1226C). Sleeve bearings, 110-120-volt, 60-cycle AC. 4-foot cord included.

- 9 KT 13462N2—Shipping weight 104 pounds \$147.50
- 9 KT 2178—20-in. Adjustable Extension. Wt. 12 lbs. . . 19.99
- 9 KT 24297—8½-in. Grid type Extension. Wt. 7 lbs. . . 14.99
- 9 KT 24291—Steel Dado Insert. Shpg. wt. 1 lb. 2 oz. . . 2.69
- 9 KT 24292—Molding Head Insert. Shpg. wt. 1 lb. 2 oz. . 2.69

Steel Floor Base for saw above. 15¼x19 ½ in., top; 19¼x24 ½ in., bottom. Heights: 23½ to 26¾ in. Unassembled.

9 KT 2226C—Shipping weight 27 pounds \$27.99

1 On-off Rocker Switch. For bench power tools; mount it yourself. For motors up to 1 HP (universal motors to 1¼ HP). 8-foot 3-wire cord. Operates on 110-120-volt AC. 15 amps. Two 3-prong receptacles—one controlled by switch; one always "on" for lamps, etc.

9 KT 12085—Shipping weight 1 pound 8 ounces \$7.99

Sears Has a Credit Plan to Suit Your Needs
See Big Book or ask for details

CRAFTSMAN® Power Shop Combination . . 8-inch Saw, jointer-planer, base plus fence, extension and motor



\$259⁰⁰

Buying this complete outfit costs far less than buying separate tools with individual motors and bases.

You get the CRAFTSMAN 8-in. tilting-arbor bench saw described at left plus 4½-in. jointer-planer attachment with tilting fence; 20-in. adjustable extension; steel base described at left; ¾-HP 3450-rpm sleeve-bearing capacitor motor for 110-120-volt, 60-cycle AC. 4-ft. cord. Guaranteed 1 yr., pg. 8.

9 KT 13 43N6—Shipping weight 179 pounds . . . \$259.00

4½-inch Jointer-Planer Attachment only. For 9KT24282N at left and former saws 99-2218, 99-2104, 99-2217, 99-2428. Tilting fence not included.

9 KT 2184C—Shipping weight 31 pounds \$59.99

Tilting Fence only. For 9KT2184C above. Adjustable. Tilts 45° to left. Positive stops at 45° and 90°.

9 KT 2181—Shipping weight 4 lbs. 7 oz. \$14.99

Compact 7½-inch Tilting-arbor Bench Saw

\$89⁹⁹

Complete with built-in, 3450-rpm capacitor motor that develops 1 HP

Cuts through wood up to 1¾ in. thick. You get a work space 26 in. wide and 14 in. long with the extensions included. 7½-in. Kromedge chisel-tooth combination blade (½-inch center hole) tilts to 45°. 6½ inches in front of blade at maximum depth of cut; 6¼ inches at 1-inch depth of cut. Dado capacity with 6-inch dado set: ¾ inch wide, 1½ inch deep. Direct-drive ball-bearing motor with thermal overload protector. Table size: 14x14 in. Overall-all dimensions: 26 in. wide, 18½ in. long. 18-in. rip fence has 15-in. work face.

Includes: Two 6-inch extensions. Aluminum blade guard with swing-away action. Convenient side-mounted on-off switch. 6-ft. 3-wire cord and adapter. Operates on 110-120-volt, 60-cycle AC. UL listed.

- 9 KT 2421C—Shipping weight 31 pounds \$89.99
- 9 KT 24212—Molding Head Insert. Shipping weight 6 ounces 1.49
- 9 KT 24211—Dado Insert. Shipping weight 6 ounces 1.49
- 9 KT 24214—Stop Rods. Shipping weight 9 ounces 2.19



12-inch Radial-Arm Saw develops 4½ HP



Our largest and most powerful . . . designed to handle tough commercial jobs. Lower retractable blade guard as standard equipment. Extra-large table provides plenty of work space. No need to buy stand. Steel legs can be mounted horizontally for use as carrying handles. Carriage glides on round replaceable steel tracks. Converts from one tool operation to another—quickly and easily.



Cuts wood up to 4 inches thick

\$369⁰⁰

It's practically a one-tool workshop. You can tenon, rip, bevel cut and bevel rip, cross cut, jack rafter, miter, plough, dado, rout, rabbet and shape with this versatile saw by itself and with accessories. Conversion from one type of operation to another requires little set-up. No belts to shift, no heavy parts to move and fasten in place. A work function chart right in front of operator makes set ups fast and effortless. Cuts from top . . . marked lines always in view.

Settings hold fast . . . give precision cuts even with repeated operations. Single-hand control keeps you in command at all times. Push-pull on-off switch with key lock provides extra safety when tool runs unattended. Electro-mechanical brake stops blade quickly. Carriage glides on sealed, permanently lubricated ball bearings. Motor, yoke and carriage easily removed. Extra-large 28½x44-in. table. Standard ½-in. arbor with ½-in. x 20-thread . . . needs no special adapters for standard accessories. 12-in. Kromedge® combination blade.

Direct drive for full power . . . no belts to replace. Permanently lubricated ball bearings on capacitor-start motor for long life. Automatic thermal overload protector resists motor burnout. Adjustable anti-kickback and splitter. Operates on 220-240-volt, 60-cycle AC. UL listed. *Guaranteed 1 year . . . see page 8.* Accessories listed at right. *See CRAFTSMAN COMMERCIAL Story on page 13.*

9 KT 2951N—Shipping weight 242 pounds. \$369.00

SPECIFICATIONS

Motor develops 4½ HP on 220/240-v. AC, 3450 RPM
 Blade size 12-in. x ½-in. hole
 Depth of cut (max.) 4 inches
 Depth of cut 45° (max.) . . . 2 1/16 inches
 Width of crosscut (maximum) in 1-inch stock 16 inches
 Width of rip (max.) 26½ inches
 Dado size 8-in. diameter x 1 3/16 in.
 Dado depth (maximum) . . . 1 1/8 inches
 Miter index stops Arm rotates 360°; fixed stops: 0°, 45°, 90° right or left

Height adjustment 10½ inches
 Yoke . . . Swivels 180° left or right with fixed stops at 0° and 90° right or left
 Bevel index Motor tilts 180°—fixed stops at 0°, 45° and 90° right or left
 Table Resin-bonded chipboard 28½x44x1 inch
 Column diameter 3 inches
 Distance from center line of column to end of arm 30½ inches
 Over-all size 38¾x44x34¼ inches high

These handy Accessories increase the kinds of jobs you can do with your CRAFTSMAN® Radial-Arm Saw

1 Hold-down Attachment. Fits most bench saws, radial-arm saws, shapers and jointers. Keeps hands away from cutting blade. Includes 2 clamps, 2 tempered steel "L" rods, 4 holding fixtures and 4 spring steel hold-down fingers. Mounting hardware and instructions also included. Shipping weight 2 pounds 11 ounces.

9 KT 3230 Set \$5.99

2 CRAFTSMAN Key Chuck. Converts your saw for routing and drilling. Precision geared. Holds standard shank boring tools up to ½ inch diameter. Fits ½-inch x 20-thread shaft. Capacity: ¼ to ½-in. key. Shipping weight 1 pound.

9 KT 2980 \$6.99

3 Miter Vise. Double-jaw vise for cutting 45° miters (90° miter joints) on all radial-arm and swing saws. Holds molding, frame sections up to 3 in. wide. Aluminum base, jaws; steel screws. For wood and metal. Shipping weight 2 pounds.

9 KT 3279 \$9.99

4 Shaper Fence. With 3-inch movement, 45° adjustment. Good for use when cutting picture, window or door frames. Steel. Shipping weight 4 pounds 3 ounces.

9 KT 2954 \$6.99



Informative Radial-Arm Saw Book

Tells all about radial-arm saws shown in this catalog. Contains complete instructions for over 200 operations concerning wood, plastic, and metal working. Also saw maintenance for peak performance. Fully illustrated. 102 pages in all. Bound in a durable red plastic cover.

9 KT 2938—Shpg. wt. 15 oz. \$3.99

CRAFTSMAN® 10-inch Radial-Arm Saw

- Direct-drive motor develops 2½ HP. . . cuts wood three inches thick
- Larger 27x40-inch work table . . . also doubles as a work bench
- Easy-to-use push-pull safety switch within convenient reach
- Color-coded controls positioned up front for fast setups
- Special electro-mechanical brake stops blade quickly



\$269.00 without stand

This new saw cuts with greater horsepower and cutting capacity than any other 10-in. radial-arm saw we've ever offered. Rugged motor develops 2.5 HP. Saw cuts to 3-in. depth. For added versatility, see accessories listed below.

Carriage glides on permanently lubricated ball bearings for a maintenance-free life and extra-smooth carriage travel. Electro-mechanical brake stops blade automatically when power is shut off . . . won't drag when saw is started. Push-pull key lock. Cuts from top. . . workpiece remains stationary so layout marks are always in full view. Standard ¾-in. arbor and ½-in. x20-thread accessory shaft . . . no special adapters needed for handling accessories. Guard equipped with adjustable anti-kickback device for safety in operation. Exclusive built-in work light.

Capacitor-start motor with permanently lubricated ball bearings. Automatic thermal overload protector. Kromedge® combination blade. Operates on 110-120 or 220-240-v. 60-c. AC. Factory-wired 110-120-v., 60 c. AC. UL listed. Order stand below. Guaranteed 1 yr. . . see page 8.

9 KT 2946N—Shipping weight 183 pounds. \$269.00

SPECIFICATIONS

- | | |
|----------------------------------------------------------------------------------|----------------------------------------------------------------------------------|
| Motor . . . develops 2.5 HP, 3450 rpm | Yoke . . . Swivels 180° left or right, fixed stops at 0°, and 90°, left or right |
| Blade size . . . 10-in., ¾-in. hole | Bevel index . . . tilts 180°, fixed stops at 0°, 45° and 90° left or right |
| Depth of cut (max.) . . . 3-in. | Scales Miter, bevel, in-and-out rip |
| Depth of cut 45° (maximum) 2½ inches | Table . . . Resin bond chip-board, 27x40x1-inch |
| Width of crosscut (maximum) 1-inch stock . . . 15½ inches | Column diameter. . . 3 inches |
| Width of rip (max.) . . . 25½-in. | Distance from center line of column to end of arm, 30½-in. |
| Height adjustment . . . 9½-in. | Overall size . . . 29¾ in. high, 40-in. wide, 34½-in. long. |
| Dado Size . . . 8-inch diameter x ¾ inches | |
| Dado depth (max.) . . . 1½-in. | |
| Miter index stops. . . Arm rotates 360°, fixed stops at 0° and 45° left or right | |

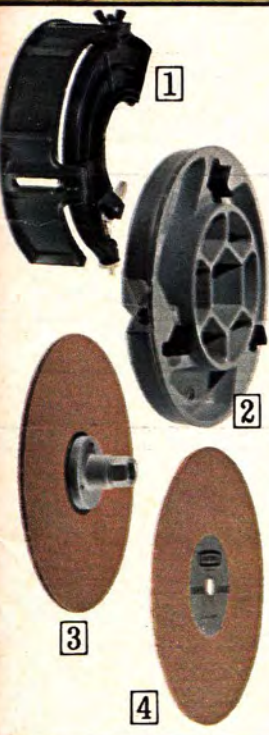

1 Molding Head Guard.

For extra protection when saw is used as a shaper. Use with molding heads and dadoes up to 7-inch diameter on page 17. Fits radial-arm saw 9KT2946N, 9KT2951N, former 9-2944, 9-2952, 9-2943, 9-2932, 9-2941. *Not for 9 KT 2922N.*

Shpg. wt. 1 lb. 1 oz.
9 KT 29524 \$8.99

Same as (1) above, but fits molding heads and dadoes up to 8 inches in diameter.
Shpg. wt. 1 lb. 8 oz.
9 KT 29523 \$8.99

2 Rotary Surface Planer Attachment.

Three blades give extra-smooth finish. With ¾-inch hole. Fits all CRAFTSMAN radial-arm saws sold in this book *except 9 KT 2922N on page 8.*

Shipping weight 1 pound.
9 KT 29512 \$6.99

Surface Planer Attachment with Carbide Tip.

Similar to (2) above, but carbide tips stay sharp much longer than non-tipped surface planers. *Not for use on 9 KT 2922N.*
9 KT 29513—Wt. 1 lb. . . . \$9.99

3 Sanding Plate.

One side medium grit, other side coarse. Diameter 10 in. Flat sanding surface measures ¾x 12-in. Acme thread hub. Fits most CRAFTSMAN radial-arm saws, saw above and saws on pages 6 and 8. Also fits former saws 9-2952, 9-2943, 9-2932, 9-2941. *Not for use with 9 KT 2922N.*
9KT22724—Wt. 4 lbs. 6 oz. \$5.99

Convert your bench saw or radial-arm saw to a disc sander. Replaceable disc.

4 8-inch Sanding Wheel.

Aluminum construction. 1 side tapered, 1 side flat. For ⅝ to ¾-inch center hole. Medium grit on both sides.
9 KT 2274—Wt. 1 lb. 3 oz. \$3.79

10-inch Sanding Wheel.

Steel. For ¾ to ¾-in. center hole. Medium grit on one side; coarse grit on the other.
9KT22723—Wt. 3 lbs. 14oz. \$4.79

Repl. Sanding Discs. For (4) above. 3-in. center hole. Pkg. of 6: 2 fine, 2 med., 2 coarse.

8-in. diameter.
9KT22732—Wt. 9 oz. Pkg. \$1.19

10-in. diameter. Wt. 12 oz.
9 KT 22731 Pkg. \$1.69

Stand Cabinet with 3 drawers and door

\$52.95 without casters

Heavy duty. Provides solid support for radial-arm saws, and other heavy tools. Use with 9 KT 2946N above, saw 9 KT 2934N, also former 9-2944 and 9-2933. Converts into a shop cart with casters (listed below). Holds 5 drawers (listed below). Door perforated to hold hooks for tools and accessories. Basic stand has top tray with 1¼-in. rim. Use with rim down as shelf or up as tray. Adjustable feet. Steel. Gray. 23½x 24¼x33 in. high. Unassembled.



Stand with back. No doors, drawers.
9 KT 1038L—Shipping weight 52 pounds. \$29.99

Stand with 3 drawers and door. See description of drawers and door below.
9 KT 10315L5—Shipping weight 87 pounds. \$52.95

Steel Drawer.* Red trim. 16¾x16 ½x4 ¼ inches deep. With mounting rails, slides.
9 KT 10328C—Shipping weight 9 pounds. \$5.99

Steel Door.* 24 ¼x20 ¾ inches. Full-length hinge. Tumbler lock, two keys.
9 KT 10336C—Shipping weight 8 pounds. \$5.99

*These accessories fit stand above and 9 KT 10265N2 on page 115.

Wheel Set (illustrated on cabinet). Strong 450-lb. capacity. Step on lever to raise plungers. Steel wheels. For stand above. Also for 9 KT 10525C, 9 KT 1071C on page 15; 9 KT 10265N2 on page 115. Also fits former 9-1026, 9-10425, 9-1030 and 9-10307. Set of four casters.
9 KT 1042C—Wt. 8 lbs. . . . Set \$13.99

Heavy-duty Caster Set (insert view). Heavy aluminum. Rubber-ball casters. Fits all stands at left. Set of 4. Wt. 8 lbs.
9 KT 1041C. . . . Set \$19.99

CRAFTSMAN® Sawdust Collector Attachment

\$14.99

Collects sawdust through 2 ¼-inch hose connected to 9 ½x10-inch shroud behind blade and through 1 ¼-inch hose connected to blade guard. Shroud easily attaches to table. Effective in crosscut, bevel cut, rip or miter positions. Fits most CRAFTSMAN radial-arm saws. Use with any CRAFTSMAN HOME-N-SHOP VAC® (page 29). Does not fit 9 KT 2922N and former saws 9-2930 and 9-2931.
9 KT 16996—Shpg. wt. 5 lbs. 6 oz. \$14.99

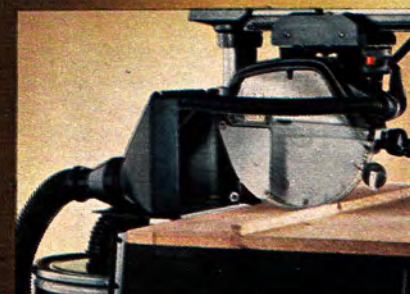

10-inch
Radial Arm Saw
develops 2-HP
cuts wood
3 in. thick

9-inch Saw
develops 1¾-HP
cuts wood
2½ in. thick



Both **CRAFTSMAN®** Saws are powered by direct drive motors for steady, even cutting. On-off safety switch can be used with strong key lock for safety when saw is unattended

\$199⁰⁰ without stand

\$159⁰⁰ without stand

Permanently lubricated ball bearings let saw glide along radial-arm . . . entire carriage mechanism moves with only slight pressure. Color-coded work function chart on top of arm for fast, easy set-ups. Thermal overload protector resists burnouts. Back end of 5/8-inch motor shaft is standard 1/2 inch x 20-thread . . . no special adapter needed.

Anti-kickback device gives protection to operator. Direct-drive, capacitor-start motor. Manually operated safety brake stops blade quickly after completed cut. Includes 10-inch Kromedge® combination blade. Stand not included (page 7). With available accessories (page 7), saw is designed to do many more workshop tasks. Saw operates on 110-120-volt, 60-cycle AC. UL listed. Guaranteed for one year . . . see details below.

9 KT 2945N—Shipping weight 100 pounds. \$199.00

New design arm and guard give added rigidity, accuracy. Cuts from top, layout marks always visible for squaring blade to fence. Permanently lubricated ball bearings. Work function chart. Push-pull safety switch with key-lock. Manual brake. Epoxy insulated motor. Blade guard has anti-kickback device. Triangular base. Die-cast aluminum. Full 5/8-inch arbor, back-end 1/2 in. x 20-thread to take standard accessories, no adapters needed. 9-in. Kromedge combination blade. 110-120-volt, 60-cycle AC. UL listed. Guaranteed 1 year . . . see below for details.

9 KT 2934N—Shipping weight 100 pounds. \$159.00

Manual Brake for former saws 9-2932 and 9-2935.

9 KT 2935E—Shipping weight 14 ounces. 5.99

8-inch Radial-arm Saw

Gear-drive universal motor develops 2-HP . . . no-load speed 5000-rpm
Compact and lightweight for easy portability from job to job

\$99⁵⁰



Handles nearly all jobs with the ease and accuracy of saws costing considerably more. Combines the quality and dependability demanded by a professional in a saw designed for the home craftsman. Carriage has set screw adjustment for heeling conditions and squaring blade to fence. Ball, roller and sleeve bearings are sealed and permanently lubricated. . . lets saw move easily along radial-arm. Anti-kickback device and safety clutch give added protection to operator, help motor resist burnouts.

With 11½-inch crosscut travel you can crosscut standard 1x12-inch stock. Armature is dynamically balanced for minimum vibration . . . wound with special heat-resistant wire. Push-pull safety switch with key-lock. Hardened helical gears give positive power transmission. Uses standard type dado (not for use with adjustable dado). 110-120-volt, 60-cycle AC. UL listed. Guaranteed for one year . . . see details at right. Shipped by motor carrier or express.

9 KT 2922N—Shipping weight 68 pounds. \$99.50

SPECIFICATIONS for 8, 9, 10-inch Radial-arm Saws on this page

	10-in. (9KT2945N)	9-in. (9KT2934N)	8-in. (9 KT 2922N)
Motor (Develops)	2 HP 3450 rpm	1¾ HP 3450 rpm	2 HP 5000 rpm
Blade size (¾ in. hole)	10 inch	9 inch	8 inch
Depth of cut (max.)	3 inches	2½ inches	2½ inches
Depth of cut 45° (max.)	2 inches	2 inches	2 inches
Width of crosscut (max.) in 1 in. stock	15½ inches	15½ inches	11½ inches
Width of rip (max.)	25¼ inches	25¼ inches	20¾ inches
Height adjustment	8¼ inches	8¼ inches	4½ inches
Dado size (x1¼ in.)	8 inches	7 inches	6 inches
Dado depth (max.)	1½ inches	1½ inches	1½ inches
Miter index stops. (All rotate 360° except 8 inch)	0°, 45°, 90° left or right	0°, 45°, 90° left or right	0° and 45° left or right
Yoke swivels 180°, fixed stops at	0° and 90° left or right	0° and 90° left or right	0° and 90° left or right
Bevel index motor tilts 180°, fixed stops at	0°, 45°, 90° left or right	0°, 45°, 90° left or right	0° and 45° left only
Scales	Miter, bevel, rip	Miter, bevel	Miter, bevel
Table (Chipboard). (Resin bond exc. 8 in.)	26x36x¾ inches	26x32x¾ inches	21¼x32x¾ inches
Column diameter	2½ inches	2½ inches	2½ inches (sq.)
Distance from center of column to end of arm	26½ inches	26½ inches	27¾ inches
Overall size	31½x36x27¼ in.	31½x32x27¼ in.	32x30¼x26in.high

CRAFTSMAN BENCH AND FLOOR POWER TOOL GUARANTEE

During the first year, upon return, we will repair CRAFTSMAN bench and floor power tools, free of charge, if defective in materials or workmanship (first 90 days for non-CRAFTSMAN). Simply return the product to any Sears Store in U.S.

Sears Has a Credit Plan to Suit Your Needs
See Big Book or ask for details

CRAFTSMAN® Precision-built Wood-turning Lathe

Big 12-inch swing . . . handles pieces up to 37 inches long and a foot in diameter accurately, even at high speeds



SPECIFICATIONS

- Swing over bed 12 in.
- Center to center 37 in.
- Length of bed 45½ in.
- Spindle, inboard end . . . ¾ in. x 16 right-hand thread with No. 1 Morse, female taper
- Ram travel 1½ in.
- Spindle bearings . . . two sealed radial thrust ball bearings
- Machine pulley (included) . . . 4-inch, 4-step V-type cone
- Mounting 49½ x 6 7/16 in.
- Tailstock taper No. 1 Morse, female
- Motor pulley (not included) . . . 4-inch, 4-step V-type cone

Head and tailstock of rugged cast-iron. Permanently lubricated ball bearings for long life. Precision-ground steel tubing bed is 45½ inches long. Motor can be mounted behind or below headstock. Headstock spindle measures ¾-inch x 16-thread with indexing pin for fluting. Rigid 3-point mount for maximum stability. Two ball bearings on spindle for easy operation. Number 1 Morse taper in headstock, tailstock.

Steel key guides tailstock and tool rest. Support and tool rest holder have double acting lock for added strength and safety. Four spindle speeds (875, 1350, 2250 and 3450 rpm). Measures 54½ inches long, 7 1/16 inches wide, 11 1/16 inches high overall. 12-inch graduated tool rest, spur, cup centers. 4-inch, 4-step machine pulley. Manual included. Shipped with motor carrier or express. Guaranteed for one year . . . see page 8 for details.

Without motor, motor pulley, V-belt or stand.

9 KT 2388N—Shipping weight 80 pounds. \$99.50

With CRAFTSMAN ½ HP, 1725-rpm split-phase motor (9 KT 1211C). For 110-120-volt, 60-cycle AC. 4 foot cord. With 4 inch, 4-step motor pulley.

9 KT 23886N3—Shipping weight 80 pounds. \$124.50

1 Work Bench. For above. Steel with 2x5-ft. laminated wood top. Unassembled.

9 KT 10271N2—Shipping weight 79 pounds. \$34.99



Versatile Speed Reducer (shown at right). Widens speed range of lathe, above, to 250-3450 rpm. Belt shifting provides low speeds for turning diameter over 6 inches and out-of-balance work pieces. Built-in belt tension adjustment for smooth operation. Cast aluminum construction. Shpg. wt. 6 lbs. 8 oz. 9 KT 2389 \$15.99



Arbors . . Centers . . Face Plates . . other Accessories

- 2 Work Arbors with Chucks. 3-jaw screw-on type. ½-inch capacity; ½-inch x 20-thread.
9 KT 22342—No. 1 Morse taper. Wt. 1 lb. 8 oz. . . \$4.99
9 KT 21522—No. 2 Morse taper. Wt. 1 lb. 10 oz. . 5.29
- 3 Work Arbors. Two steel flanges; nut on head end for clamping wheels. ½-inch x 20-thread.
9 KT 21532—No. 1 Morse taper. Wt. 11 oz. . . \$3.29
9 KT 21522—No. 2 Morse taper. Wt. 13 oz. . . 3.29
- 4 Chuck Arbors. No. 1 Morse. No. 33 Jacobs taper.
9 KT 2123—Shipping weight 5 oz. \$3.49
No. 2 Morse and No. 33 Jacobs taper.
9 KT 2124—Shipping weight 8 oz. 2.69
No. 1 Morse and No. 33 Jacobs taper.
9 KT 2154—Shipping weight 8 oz. 3.29
No. 2 Morse and No. 33 Jacobs taper.
9 KT 2126—Shipping weight 9 oz. 2.69
- 5 Screw Centers. For woodworking.
9 KT 21162—No. 1 Morse taper. Shpg. wt. 8 oz. 2.99
9 KT 21152—No. 2 Morse taper. Shpg. wt. 12 oz. . 2.99
- 6 Ball-bearing 60° Centers. For hardwood, metal.
9 KT 21122—No. 1 Morse taper. Wt. 11 oz. \$4.49
9 KT 21132—No. 2 Morse taper. Shpg. wt. 13 oz. 4.49
- 7 Spur Centers. Use for wood turning.
9 KT 21062—No. 1 Morse taper. Shpg. wt. 6 oz. 2.69
9 KT 21072—No. 2 Morse taper. Shpg. wt. 9 oz. . 3.29

- 8 Tailstock Cup Centers. For wood turning.
9 KT 21002—No. 1 Morse taper. Wt. 5 oz. . . \$2.49
9 KT 21012—No. 2 Morse taper. Wt. 6 oz. . . . 2.79
- 9 60-degree Centers. For metal turning.
9 KT 21102—No. 1 Morse taper. Wt. 5 oz. . . 2.19
9 KT 21112—No. 2 Morse taper. Wt. 6 oz. . . . 2.19
- 10 Work Arbors. Convert motor to grinder, polisher, etc. 3 3/8 inches long. 2 3/8-inch spindle. ½-inch x 20-thread. Sturdy steel flanges.
9 KT 21643—½-inch bore. Wt. 14 oz. . . . \$2.39
9 KT 21644—¾-inch bore. Wt. 14 oz. 2.39
- (11 and 12) Lathe Centers. For former 99-2162 or ¾-inch unthreaded arbor.
(11) 9 KT 21052—Headstock Spur. Wt. 7 oz. . \$2.29
(12) 9 KT 21022—Tailstock Cup. Wt. 7 oz. . . 2.29
- 13 Comb. Face Plate, Sanding Plate. Cast iron. For inboard turning, sanding. 8-in. diam. ¾-in. x 16 right-hand thread. Sanding disc, cement.
9 KT 24905—Shpg. wt. 4 lbs. 4 oz. \$7.99
- 14 Face Plate. For ¾-in. x 16 right-hand thread arbor. 4-in. diameter. For inboard turning.
9 KT 2489—Shipping weight 1 lb. 12 oz. . . . \$4.99
- 15 Face Plate. With 3-inch diameter. Cast iron. With spurs, removable center, screw center. Fits ¾-in. x 16-thread spindle.
9 KT 20912—Shipping weight 1 lb. 12 oz. . . . \$6.99

- 16 4-piece Carbide-tipped Wood-turning Set. Stays sharp 20 times longer than ordinary steel. 10-inch handles. For wood, plastic, aluminum, brass. Set includes ½-inch parting tool, ½-inch gouge, one each ¾-inch round-nose and ¾-inch skew chisel.
9 KT 3629—Shpg. wt. 2 lbs. 6 oz. Set \$21.99
- (17 thru 24) Wood-turning Tools. Polished 4 ½-inch carbon steel blades, ground to hold edge. 10-inch handles, heavy ferrules.
(17) 9 KT 2863—1-in. skew chisel. Wt. 11 oz. \$3.29
(18) 9 KT 2862—¾-in. skew chisel. Wt. 11 oz. 2.99
(19) 9 KT 2858—¾-in. parting tool. Wt. 11 oz. 2.99
(20) 9 KT 2856—¾-in. round nose. Wt. 11 oz. 2.99
(21) 9 KT 2854—¾-in. spear point. Wt. 11 oz. 2.99
(22) 9 KT 2852—¾-in. gouge. Wt. 13 oz. . . . 3.29
(23) 9 KT 2851—¾-in. gouge. Wt. 11 oz. . . . 2.99
(24) 9 KT 2850—¾-in. gouge. Wt. 10 oz. . . . 2.99

5-piece Set. As described above. Set includes ¾-inch gouge (23), ¾-inch parting tool (19), one each ½-inch spear point (21), ½-inch round nose (20), and ½-inch skew chisel (18).
9 KT 2855—Shpg. wt. 2 lbs. 4 oz. Set \$12.99

Only the CRAFTSMAN® 12-inch Band-Saw-Sander gives you these 10 exclusive features

1

\$159⁹⁵

without rip fence, miter gauge, base, motor, belt guard

2

3

4

- Sawdust ejection system . . . use with HOME-N-SHOP® vac
- Color-coded controls for fast set-ups
- Scales for proper blade and belt tension can be read from the inside or outside
- Micro-adjust upper and lower blade guides
- Spring tension on upper guides prevents guard from dropping during height adjustment
- Sight lines on guides for correct setting
- Built-in work light for better visibility
- Built-in on-off switch, outlet and power cord
- Extra fast cutting hook tooth blade
- Sanding attachment with sanding belt included

1 Look at these other important features, too: Heavily ribbed 14½x12½-in. cast-iron work table tilts from 0° to 45° . . . calibrated bevel scale. Large table insert speeds setups . . . does not move when workpiece is turned. Adjustable table stop. Balanced, true-running wheels with rubber tires for better blade life and tracking. Tires replaceable . . . no adhesive needed. Measures 38 in. high. Cuts to center of 24-inch circle in wood up to 6 inches thick. 2x7½-inch or 6x12-inch re-sawing capacity. Blade speed 2900 ft. per minute. 5-in. machine pulley, 2½-inch motor pulley. 43-inch belt. Use minimum of ¼-HP, 1725-rpm motor (motor not incl.). Order base, belt guard, rip fence and miter gauge below. Guaranteed 1 year . . . page 8.
9 KT 2429N—Shipping weight 74 pounds . . . \$159.95

With motor (9 KT 1211C). ¼-HP, 1725-rpm, sleeve-bearing, split-phase CRAFTSMAN. 110-120-v., 60-c. AC. 4-ft. cord.
9 KT 24293N2—Separately \$189.94. Shipping wt. 92 lbs. . . \$184.95

SPECIFICATIONS

- Distance from blade to column 12 inches
- Thickness of cut (maximum) 6 inches (7½ inches on material up to 2 inches wide)
- Table size 14½x12½ inches wide
- Length of blade 80 inches
- Width of blade (takes ⅛ to ½-inch widths) ¼ inch
- Blade speed 2900 feet per minute
- Machine pulley (included) 5 inches
- Motor pulley (included) 2½ inches
- Motor recommended (minimum) ¼ HP, 1725 rpm
- Size (without base) 38 in. high x 26 in. wide x 14½ in. deep.
- Table tilts and locks in any position from 0° to 45°
- Ball-bearing thrust rollers

2 Band Saw Rip Fence. Rips planks and boards evenly at predetermined widths. Locks at front . . . won't slip. Necessary fittings included. Use ¼-inch blade. Tilts to 45° left.
9 KT 23432—Shipping weight 4 pounds 10 ounces . . . \$14.99

3 CRAFTSMAN Miter Gauge. For saw above and most saws with ¾x¾-inch miter slots. Stops at 0°, 45° left and right.
9 KT 29929—Shipping weight 4 pounds 5 ounces . . . \$11.99

4 Steel Floor Base. Rubber-capped feet guard against creeping. 24½ in. wide, 20 in. deep. Height adjusts from 27¼ in. to 30½ in. Motor mount incl. Shipped unassembled.
9 KT 2224C—Shipping weight 35 pounds . . . \$29.99
9 KT 22242—Belt Guard. Use with (4). Wt. 1 lb. 15 oz. . . . 2.99
Replacement Sanding Belts for (1). ¼x80 in. Pkg. of 5.
9 KT 22361—Shipping weight 10 ounces Package 2.19

Professional Band Saw Blades

Cut exceptionally fast and smooth. Use as replacement blades for cutting wood, nonferrous metals or steel.

All blades made of special alloy steel, then heat-treated and hardened. Precision ground to give maximum life. Every blade is endless . . . set and filed for its recommended use.

Catalog Number	For sawing	Width in.	Length in.	Shpg. wt.	Each
9 KT 26641	Wood	¼	62	5 oz.	\$1.99
9 KT 26642	Wood	⅜	62	5 oz.	1.99
9 KT 26572	Wood	¼	78	6 oz.	2.49
9 KT 26232	Wood	¼	80	6 oz.	2.49
9 KT 26233	Wood	⅜	80	7 oz.	2.49
9 KT 26234	Wood	½	80	8 oz.	2.49
9 KT 2624	Brass, non-ferrous metals	¼	80	6 oz.	2.99
9 KT 2625	Steel	¼	80	6 oz.	3.99
9 KT 26581	Wood (fine scroll cutting)	⅜	54	4 oz.	1.99
9 KT 26582	Wood hard-board, plywood, chipboard	⅜	54	4 oz.	1.99
9 KT 26584	Wood	¼	54	4 oz.	1.99
9 KT 26592	Plywood	⅜	80	4 oz.	2.49
9 KT 26593	Plywood	¼	80	6 oz.	2.49
9 KT 26255	Steel	⅜	54	4 oz.	2.99

†Fine-tooth for minimum splintering and smoother finish cuts.

Sears Has a Credit Plan to Suit Your Needs
See Big Book or ask for details



CRAFTSMAN® 18-inch belt-driven Jig Saw

Convert from Jig to Sabre Saw by removing arm

\$99.00 without base, motor, pulley guard

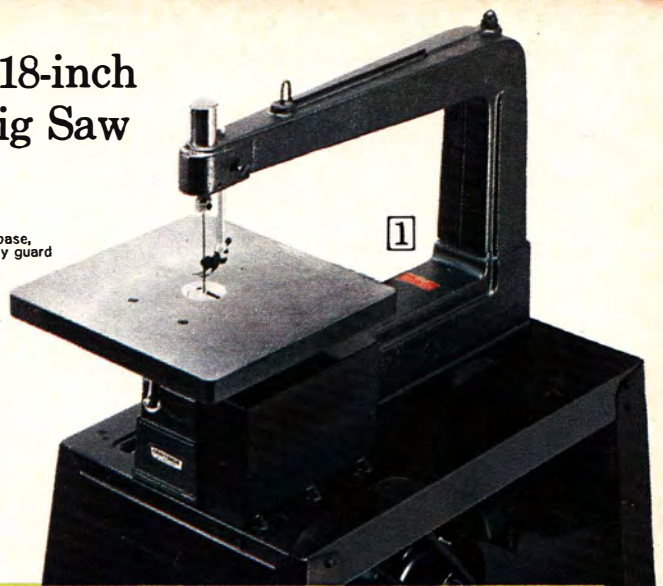

1 Ideal for fine scroll work in wood, nonferrous metal and plastic . . . unlimited capacity as a sabre saw by simply removing arm. Big 12x12-inch table has calibrated bevel scale . . . tilts 45° to the left for bevel cutting. Upper and lower blade guides have ball bearings for a long, dependable life. Spring hold-down foot keeps work steady at various blade thicknesses. Blade chucks let you use flat end blades up to 3/4-inch wide . . . adjustable for straight blade alignment. Rotate 90 degrees for straight or scroll cutting material longer than 18 inches. Sawdust blower keeps line of cut clear. Runs in oil bath for smooth, quiet operation. 1-year guarantee . . . see page 8.

9 KT 2072N—Shipping weight 71 pounds \$99.00

With CRAFTSMAN 1/2-HP, 1725-rpm, sleeve-bearing, split-phase motor (9 KT 1211C) 110-120-v., 60-c. AC. 4-ft. cord. 9 KT 20724N2—Shipping weight 89 pounds \$124.95

2 Steel floor base only. Adjusts 27 1/2 to 30 1/2 in. high. 9 KT 2223C—Unassembled. Shipping weight 35 pounds. 29.99

Pulley Guard for above. Encloses pulley, belt above base. 9 KT 22232—Shipping weight 1 pound 10 ounces \$2.99

SPECIFICATIONS

- Depth of throat 18 inches
- Table size 12x12 inches
- Sawdust blower built-in
- Stroke 1 inch
- Depth of cut (max.) 2 inches
- Bearings porous bronze
- Blade 6-inch plain-end
- Cutting strokes per minute approximately 875
- Machine pulley (included with saw) 4 inches
- Motor pulley (included with saw) 2 inches
- Motor recommended (minimum) 1/2-HP, 1725-rpm
- Mounting dimensions (three-point) 5 1/2 x 22 1/4 in.
- Dimensions 18 inches high, 12 inches wide, 29 inches long

18-inch Band Saw

\$699.00 without motor

Cuts to the center of a 36-in. circle in wood 12 in. thick. Setups can be made in minimum time. Ball bearing gear reduction assembly; 4 blade speeds: 118 to 3550 ft. per min. Table tilts to 45° . . . locks. 2 11-ft. blades (3/4-in. metal-cutting and 1/2-in. wood-cutting), 2 miter gauge slots, miter gauge, 2 rubber-tired ball-bearing wheels. V-belt. Steel frame. 1-year guarantee . . . page 8. See Shipping Note below. See CRAFTSMAN COMMERCIAL story on page 13. F9 KT 2358N—Shipping weight 407 lbs. \$699.00

Rip Fence for saw above. Sent unassembled. F9 KT 23586—Shipping weight 13 lbs. \$29.99

Shpg. Note: Saw and fence from Cincinnati, Ohio factory. No C.O.D.'s. For saw, pay motor carrier or express charges from factory. For fence, pay postage from c. o. plant.

SPECIFICATIONS

- Depth of throat 17 inches
- Depth of throat without shroud 18 inches
- Capacity of cut (maximum) 12 inches
- Table size 20 1/4 x 17 1/4 inches wide
- Bearings 6 sets of grease-sealed ball bearings
- Wheel size (each wheel) 18 inches
- 4-step machine pulley (included) 7 inches
- 4-step motor pulley (included) 3 inches
- Dimensions overall Height 75 inches, width 22 1/2 inches, depth 31 inches
- Motor (not incl.) minimum 1-HP, 1725-rpm

11-ft. Blades for saw above. From Boone, N.C. factory. No C.O.D.'s. Allow extra time. Postpaid.

Width	Catalog No.	Teeth	Cuts	Sizes	Wt.
For metal Each \$5.99					
3/4-in.	F9 KT 27525	18 per in.	0 to 3/4 in.	(8 oz.)	
1 1/2-in.	F9 KT 27526	14 per in.	3/4 to 1 1/2 in.	(10 oz.)	
1 1/2-in.	F9 KT 27527	10 per in.	3/4 to 2 in.	(12 oz.)	
3/8-in.	F9 KT 27524	8 per in.	2 in. and up	(14 oz.)	
For wood Each \$3.99					
3/4-in.	F9 KT 27151	6 per in.	Use on woods	(5 oz.)	
3/4-in.	F9 KT 27152	6 per in.	to size limit of	(6 oz.)	
3/8-in.	F9 KT 27153	6 per in.	band saw	(8 oz.)	

10-inch Hobby Jig Saw . . fun for any age

Not CRAFTSMAN. Operates so easily a child can learn to use it. Short, fast strokes cut neatly, leave almost no saw marks . . . there's little or no sanding to do. Does full-scale cutting in soft woods, plywood, Masonite Presdwood®, plastics . . . even thin aluminum, brass or copper. Motor needs no oiling. No belts or pulleys.

Tempered spring steel blade return maintains cutting tension. Rubber feet. Table with 1/2-inch grid pattern aids guiding. 6-ft., 2-wire SJ cord, instructions, 2 blades. UL listed. 90-day guarantee . . . see page 8.

9 KT 2478—Wt. 9 lbs. 6 oz. \$17.99

SPECIFICATIONS

- Throat depth 10 in.
- Depth of cut (soft wood) 1 inch max.
- Chuck stationary
- Motor (built in) magnetic type, 110-120-v., 60-c. AC.
- Table 6 1/2 x 8 1/2 in.
- High speed stroke 7200 per minute
- Bearings torsion
- Blades 4-in. pin end
- 7 3/8 x 6 x 14 1/2 in. long

\$17.99



CRAFTSMAN® Alloy steel Jig Saw Blades

Professional quality . . . heat-treated and hardened for long use and fast cutting. All blades listed are for use on jig saws. 6-inch plain-end blades can be snipped off to fit machines taking shorter plain-end blades. When cutting metal with blades indicated for metal cutting, lubricate blade with beeswax. Sabre-saw blades can be used for heavy work as well as sabre sawing on jig saws.

Shipping weight 2 ounces per package.

Catalog Number	lgth. inches	Width inches	Thick. inches	Teeth per in.	Recommended uses	No. in pkg.	Per pkg.
(Pin-type blades)							
(3) 9KT2688	.4.	.062	.010	18	For wood and plywood. Fit magnetic or reciprocating-motor jig saw.8.	59c
9KT2687	.4.	.082	.010	18	For wood and plywood. Fit magnetic or reciprocating-motor jig saw.8.	59c
9KT26903	.5.	.095	.015	20	For wood, plastic, soft metal. Fit magnetic or reciprocating-motor jig saw.4.	59c
(4) 9KT27053	.5.	.110	.020	15	Medium; for wood or metal.4.	59c
9KT27083	.6.	.110	.020	15	Wood or metal.4.	59c
(Plain-end blades; for most jig saws)							
9KT26901	.5.	.110	.020	15	Wood or metal.4.	59c
9KT27013	.6.	.110	.020	15	Fine; for wood and soft metal.4.	59c
(5) 9KT27023	.6.	.085	.020	15	Extra fine; for wood and soft metal.4.	59c
(6) 9KT27003	.6.	.110	.020	10	Coarse; for wood and soft metal.4.	59c
(7) 9KT27093	.6.	.110	.020	20	For thin sheet metals, including steel.4.	59c
(Fo. use with 9 KT 2072N above as Sabre Saw)							
(8) 9KT28673	.6.	.250	.028	20	For wood and metal.3.	79c
(9) 9KT28693	.6.	.187	.028	10	For wood and soft metal.3.	79c
(10) 9KT28663	.6.	.250	.028	7	For coarse cuts in wood.3.	79c

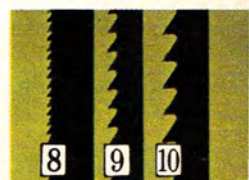
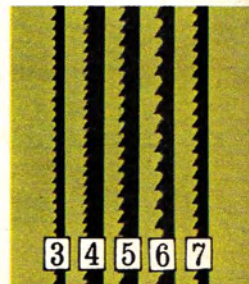

Only CRAFTSMAN® 15½-inch Drill

Include 4 exclusive features: 8 operating speeds (instead of usual 4) from 380 to 8550 rpm. Powerful torsion spring for positive quill return is inside the head. Can be adjusted quickly without endangering operator's hands. Up-front chart shows correct drill size and speed for precision drilling in metal, wood or plastic. Up-front built-in motor switch, outlet and power cord.

Plus: Streamlined 1-piece cast-iron head plus balanced drive for extremely accurate drilling. Power cords inside drill head . . . meet all safety codes. 6-in. diam., 8-step cone-type motor and machine pulleys give complete speed range without reversing or raising motor pulley. Steel splines in drive pulley for true running, long life. ¾x45-in. V-belt delivers maximum torque.

Exclusive color-coded controls tell you what to do and how to do it—simplify adjustment and operation. Basic operating instruction panel on front of head with color-coded speed selector chart. Built-in worklight. Built-in power switch and light switch operate independently. Diagonal slots in 10x12 ½-inch work table. 1 ½-inch diameter quill. ½-inch diameter spindle. Depth scale is graduated in ¼ inches.

Without motor. See specifications at right.

Floor model.

9 KT 2459N—Shipping weight 190 lbs. . . . \$179.95

Bench model.

9 KT 2458N—Shipping weight 153 lbs. . . . 169.95

With sleeve-bearing motor (9 KT 1214C). ½-HP. 1725-rpm, capacitor-start. Operates on 110-120-v., 60-cycle AC. UL listed. Incl. 4-ft. cord.

Floor model.

9 KT 24591N2—Shipping weight 211 lbs. . . . \$219.95

Bench model.

9 KT 24581N2—Shipping weight 174 lbs. . . . 209.95

Quick change guard completely encloses belt. Hinged motor mount. Permanently lubricated precision ball-bearings on pulleys and spindle. 3-jaw chuck (0 to ½-in. capacity) locks securely to solid spindle . . . doesn't drop on side-thrust loads. Chuck key storage space. Bit not included.

Big 4 ¼-in. quill bearing surface contact during full stroke for greater precision. Micro-adjust pointer on depth gauge. Cast-iron work table is slotted to hold fixtures: has parallel edges for clamping workpieces to table. Drill head and table held in position on 2 ¼-in. steel column by clamps which lock with levers. Column collar prevents head or table from dropping during adjustment. Parallel slots in base. Use min. ½ HP, 1725-rpm motor (not incl.). Guaranteed 1 year . . . page 8.

SPECIFICATIONS

- 8 speeds. 380 to 8550 rpm
- Depth of throat. 7 ¾ inches
- Spindle. Number 33 Jacobs taper
- Bearings. 2 sets of 2 precision ball
- Chuck capacity. 0 to ½ inch
- Spindle travel. 4 inches
- Quill diameter. 1 ½ inches
- Depth graduations. 1/16 inch
- Work surface. 10x12 ½ inches
- V-belt (included). ¾x16x45 inches
- Machine pulley (included). 6 inches, 8-step
- Motor pulley (incl.). 6 in., 8-step with ¾-in. bore

Measurement	Floor model	Bench model
• Table travel.	42 ½ in.	15 ½ in.
• Distance, base to chuck, maximum.	48 ¾ in.	19 ¾ in.
• Mounting dimensions.	14 ¾x11 ½ in.	14 ¾x9 in.
• Height.	72 in.	43 ¾ in.
• Width.	15 in.	11 ¾ in.
• Depth.	27 in.	27 in.



Floor model without motor or bit
\$179⁹⁵

Bench model without motor or bit
\$169⁹⁵

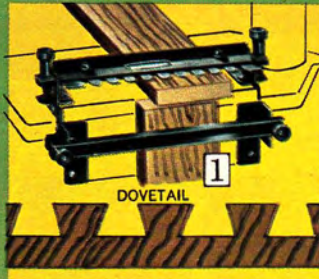

1 Dovetailing Attachment.

Makes accurate dovetail joints. Clamp holds workpieces at 90°; cuts both at same time. Hardened-steel slotted comb controls spacing and depth of cut. End plates, comb, screw fittings, clamps, wood parts included. Use with ¼-inch dovetailing bits only (not incl.).

Instructions show how to make dovetail joints like those used in manufacturing fine furniture. Duplicate joints used in making drawers, chests, etc.
9 KT 2462—Wt. 5 lbs. 10 oz. \$19.99

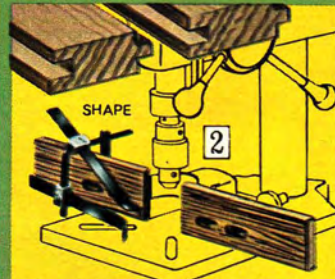

2 CRAFTSMAN Shaper Fence Attachment.

Fits drill presses above and those on facing page. Converts drill press into shaper. Forms support for making picture frames, sashes, moldings and trimmings. Hardwood fences open 1 to 3 in. Each adjusts separately. Micrometer-type adj. with 1 ½-inch max. forward, back travel.

Hold-downs keep pressure on work. Shift ends of unit for reg. or reverse feeds.
9 KT 2487—Wt. 6 lbs. 2 oz. \$19.99



3 CRAFTSMAN Hold-down and Guide.

Fits almost any drill press table. For mortising, routing, planing, repetitive drilling. Strong cast-iron construction throughout.

Fingers on hold-down prevent workpiece from lifting when chisel or drill is raised . . . keeps work lined up. Easily adjustable to thin and thick work materials. Hold-down and guide bolt to table. Bolts are not included.

Shipping weight 6 lbs. 2 oz.
9 KT 2457 \$8.99

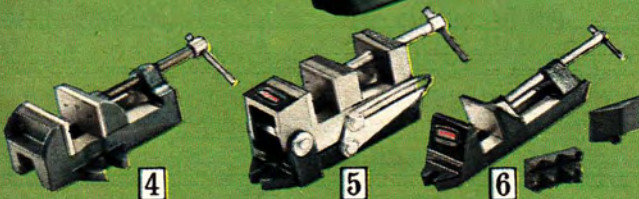

(4 and 5) Drill Press Vises. Sturdy cast iron. Jaws are steel-faced . . . one face grooved . . . one plain.

4 General purpose Vise.

Precision steel adjusting screw holds jaws firmly for accurate use of your drill press . . . fewer errors . . . less wasted materials. 3-in. wide jaws open to 3 in. . . built to hold curved or tapered pieces, 8 in. long. Mounting lugs. No bolts. Heavy-duty construction. Wt. 8 lbs. 2 oz.
9 KT 2757 \$13.99

5 CRAFTSMAN Angle Vise.

Fast, accurate, without clamps, wedges. Adjust 0° to 90° or use horizontally. Use with magnetic chuck, too. 2 ½-in. wide jaws open max. 2 ½ in. 9 in. long.
Shipping weight 8 lbs. 4 oz.
9 KT 2754 \$13.99

6 Drill Press Work Holder.

Cast-iron base: 10 ½ inches long, 2 ½-inch steel-faced jaws open 3 inches at maximum. Extra cast-iron jaws . . . 1 for irregular work and 1 for tapered work.
9 KT 2437—Wt. 4 lbs. 15 oz. \$7.99

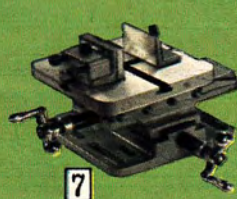

7 Universal Compound Vise.

Bolts to drill press table. Also adapts to shapers, lathes, milling machines, grinders. Work is locked on 7x7-inch table between adjustable jaws. Maximum opening 4 ¾ in.

One jaw swivels, other has movable face. 6 ½-inch cross feed travel (lower) . . . 5 ½-inch traverse feed travel (upper). Upper slide graduated 90° right or left. With wrench, bolts. Wt. 35 lbs.
9 KT 2432C \$79.50



8 CRAFTSMAN Rotary Table

with cross slide. Use for layout and indexing . . . as rotary milling table. For drill presses, milling machines, surface grinders and shapers.

Eight-in. diam. table rotates 360°. Rotary dial calibrated in 3-min. intervals. Dual cross feed, 2 ½ in. on each side, 4 ¾ in. over-all.

Dials in 1000ths. Vise jaws incl. Removable jaw set 2 ¼ inches wide. 5 inches high. Shipping weight 41 lbs.
9 KT 2495L \$149.95

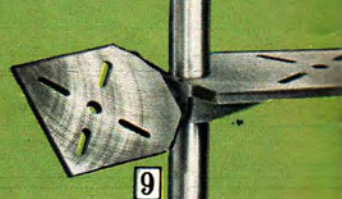

9 Tilt Table for drill presses.

Makes end, angle routing and drilling simpler, more precise. Rugged 8 ¾x11 ½-inch cast-iron table with ground flat surface. Indexes at 45° and 90°, left or right. Designed so long workpiece clears column when clamped to table at 90°. Can be used without knocking down set-up on normal table. Includes mounting hardware. Shpg. wt. 25 lbs.
9 KT 2439C \$14.99

Presses offer 8 operating speeds



Industrial-quality . . . built for continuous duty operation

Without motor, bit or rotary table

\$239⁹⁵

With motor, without bit or rotary table

\$289⁵⁰

- Eight speeds380 to 8550 rpm
- SpindleNo. 33 Jacobs taper
- Chuck capacity0 to 1/2 inch
- Quill diameter1 1/4 inch
- Work surface14x14 1/2 inches
- Machine pulley (incl.) . . .6-in., 8-step
- Motor pulley (included) . . .6-inches, 8-step; 3/4-inch bore keyed
- Drive splines6
- Table travel42 1/2 inches from table to chuck, maximum

- Depth of throat7 3/4 inches
- Bearings2 sets of 2 precision ball
- Spindle travel4 inches
- Depth graduations1/2 inch
- V-belt (included)3/4x45 inches
- Distance (chuck to base) . . .48 1/2 in.
- Mounting Dimensions . . .14 3/4x11 1/2 in.
- Height72 inches
- Width15 inches
- Depth27 inches

Sears Best. Equipped with all the outstanding features (except built-in worklight) that are on the facing page. Designed for close tolerances and extreme accuracy for tool and die work, commercial drilling and other industrial applications. With attachments (below, facing page), unit can mortise, dovetail, rout, shape, carve, or plane. *Exclusive* pinion backlash take-up and pre-loaded, double-row, lower spindle bearing minimize quill drop and prolong long-drill life. *Exclusive* tap and drill chart shows correct drill size for tap.

Split head with take-up adjustment to compensate for wear. Built-in push-pull safety switch. Big 14x14 1/2-inch work table with "T" slots and oil troughs. Quill diameter is 1 1/4 inch. Spindle diameter is 3/4 inch.

Depth gauge graduated in 1/32 inch. From base to chuck is 47 3/4 inches. Measures 15x21x72 1/2 inches high overall. Maximum table travel 41 1/2 inches. Motor not included. Order rotary indexing table (8) from facing page.

9 KT 2463N—Shipping weight 196 pounds \$239.95

With CRAFTSMAN ball-bearing motor (9KT1213C). 1/2 HP, 1725-rpm capacitor-start. Strong, moisture resistant windings. Overload protector. 110-120 or 230-v., 60-c. AC. UL listed. 4-ft. cord. *Separate prices total \$294.94.*

9 KT 2463IN2—Shipping weight 218 pounds \$289.50

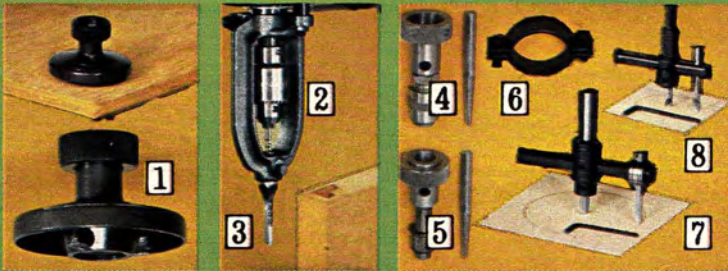

1 CRAFTSMAN Rotary Planer. Converts drill press to planer. Dresses, trues up, finishes wood surfaces. Also removes paint and varnish. Fits CRAFTSMAN drill presses above, facing page, others with No. 33 Jacobs taper. 1 1/8-in.x20-thread side-thrust nut or locking collar. 3 3/8-in. diameter. With hex wrench, instructions.

Shipping weight 1 pound.
9 KT 2745 \$8.99

2 Mortising Chisel-Housing. Holds hollow chisels below. Fits CRAFTSMAN drill presses with 1 1/4 or 1 1/2-in. diameter quill. Mounts on quill.

Shipping weight 4 pounds 2 ounces.
9 KT 2465 \$7.99

3 Hollow Chisels. For former 9-2464, 9 KT 2465 above. Wt. each 4 oz.

Catalog No.	Size	Cut depth	Each
9 KT 24201	1/4-inch	1 1/2-inch	\$4.99
9 KT 24202	3/8-inch	3 -inch	5.19
9 KT 24203	1/2-inch	3 -inch	5.49

Mortising Bits. (Not shown.) For above. Shipping weight each 4 ounces.
9 KT 24221—1/4-inch size \$3.49
9 KT 24222—3/8-inch size 3.99
9 KT 24223—1/2-inch size 4.39

4 Collet Chuck with holding collar. For wood-working cutters (8), (9) and (10) on page 41; others with 1/2 or 3/4-inch shank. Fits drill press spindle with No. 33 Jacobs taper.

9 KT 24672—Shipping weight 10 oz. \$4.99

5 Adapter with holding collar. For 1/2-inchx20-thread spindle. Fits drill presses on both pages, most former CRAFTSMAN models or models with No. 33 Jacobs tapered spindle.

9 KT 24832—Shipping weight 12 oz. \$4.99

6 Column Collar. Prevents head from falling when rotating. Install or remove without removing head from column. Fits presses with 2 3/4-in. col.

9 KT 2438—Shipping weight 1 lb. \$1.99

7 CRAFTSMAN Heavy-duty Circle Cutter. 1/2-in. shank. Cuts holes 1 1/4 to 7 1/2 in. diam. in steel, brass, wood, plastic. Steel bit, set-screw wrench.

9 KT 3640—Shpg. wt. 14 oz. \$5.49

8 CRAFTSMAN Circle Cutter. 1/4-in. shank. Use in drill press or bit brace. Cuts holes 1/2 to 4-in. diam. in wood, brass, plastic. Includes high-speed steel bit, set-screw wrench.

9 KT 3645—Shpg. wt. 7 oz. \$2.49

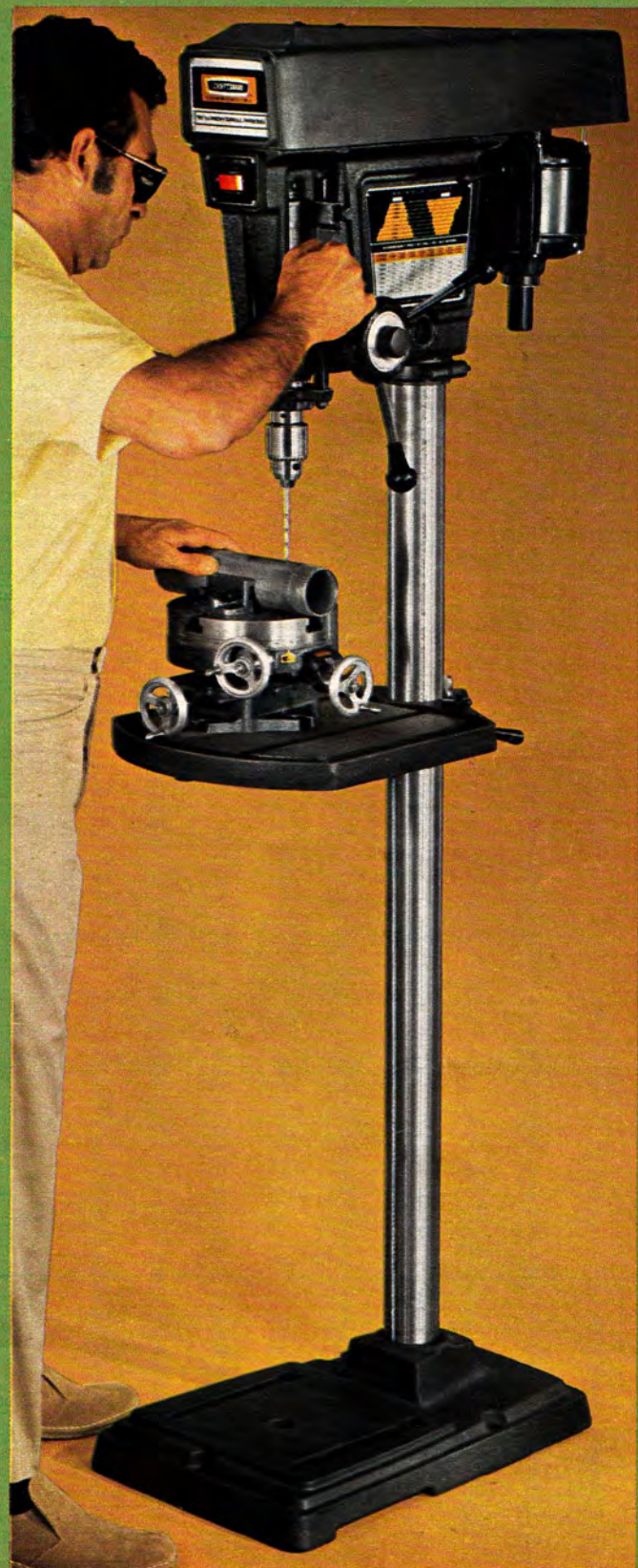

Look for this label . . . it means top quality



- A specially designed tool to meet the exacting requirements of industrial use
- Extra heavy duty to stand continuous operation
- Superb precision construction for extra accuracy
- And a Sears price that makes it an outstanding buy for the professional and the home craftsman who demands the very top quality in tools

Versatile Drill Press Tapping Head Kit

Attaches to 1/2-in. capacity chucks of any drill press with spindle speeds from 500 to 3500 rpm. Hole tapping capacity is from #10 to 3/8 in. Tapper increases drill press torque by means of a 4:1 planetary gear reduction system. Requires no special skill to operate. When tap comes into contact with work piece, all-metal positive-action clutch engages. Tap direction automatically reverses when drill press handle is raised. Kit includes tapping head, steel storage case, extra tap chuck collet, chuck nut and body wrench, column stop and 2 hex keys.

Shipping weight 8 pounds 10 ounces.
9 KT 2431 Kit \$79.99



CRAFTSMAN® Jointer-Planers

Industrial and home-workshop sizes



1

6 1/4-inch size—
our largest-capacity,
most accurate Jointer-Planer

Without floor base, motor, machine pulley guard

\$169.00

1 Handles stock up to 6 in. wide. Large work table area increases accuracy compared with 4 1/4-in. size at right. Base, rear table, legs cast in one piece. Cast iron fence extends full length of rear table, locks flush—stops at 45° and 90°. Bearing housing part of base casting. Depth of cut scale in full view of operator; 6 micro-adjustment screws align 3 alloy steel blades. Rabbets to 1/2-inch depth. Two sets sealed ball bearings, permanently lubricated. Includes machine and motor pulleys and V-belt. No motor or floor base. *Guaranteed 1 year—see p. 8.*
9 KT 2062N—Shipping weight 122 lbs. \$169.00

Jointer-Planer with motor (9 KT 1216C), 1/2 HP, 3450 rpm. Sleeve-bearing capacitor-start. 4-ft. cord.
9 KT 20623N2—110-120-v., 60-c. AC. Wt. 141 lbs. . \$204.95

Steel Floor Base for Jointer-Planer (1) above, similar to Base (3), right. Table top 37 1/2 x 15 1/4 in. Height adjusts 27 1/2 to 30 1/2 in. Leveling feet, rubber pads. Motor mount incl. Unassembled. Sent motor carrier, express.
9 KT 2229N—Shpg. wt. 42 lbs. \$29.99

Protective machine pulley Guard. Covers V-belt, machine pulley above table surface. For steel base above.
9 KT 22291—Shpg. wt. 2 lbs. \$2.99

Extra Knives. Package of 3.
9 KT 2293—Shpg. wt. 13 oz. Pkg. \$6.99



2

4 1/4-inch Jointer-Planer

Without floor base or motor **\$99.00**

2 Fence lock handle minimizes "whip." Semi-steel tables . . front table adjusts cutting depth. Three-point suspension provides for perfect alignment with cutter head. Removable spring-loaded guard. Steel cutter with three 4 1/2-in. blades included. Self-lubricating sleeve-bearings. Fence tilts 45° either side. Machine and motor pulleys, V-belt included. No motor or stand. *Guaranteed 1 year, p. 8.*
9 KT 2186L—Shipping weight 62 lbs. \$99.00

Jointer-Planer with motor (9 KT 1216C)—1/2 HP, 3450 rpm. Sleeve-bearing, capacitor type. 4-ft. cord. 110-120-volt, 60-cycle, AC operation.
9 KT 21861L2—Shipping weight 81 lbs. \$134.50

Extra Cutler Knives for above. Package of 3.
9 KT 21866—Shipping weight 6 oz. Pkg. 4.99

3 Steel Floor Base for above Jointer-Planer. Table top measures 25 1/2 x 15 1/4 in. wide. Height adjusts 27 1/2 to 30 1/2 inches. Leveling feet plus rubber pads help eliminate vibration. Motor mount included. Order guard below. Unassembled.
9 KT 2223C—Shipping weight 35 lbs. \$29.99

Machine Pulley Guard. Fits above Floor Base.
9 KT 22231—Shipping weight 1 lb. 4 oz. 2.99

SPECIFICATIONS for 6 1/4-inch and 4 1/4-inch Jointer Planers

Model Number	9 KT 2062N	9 KT 2186L
Width of cut	6 1/4 inch	4 1/4 inch
Depth of cut (maximum)	1/2 inch	3/8 inch
Front table	16 1/2 x 8 inches	11 1/2 x 6 1/2 inches
Rear table	18 1/2 x 6 1/2 inches	11 1/2 x 5 1/2 inches
Cutter knives (3)	6 1/4 x 1 1/2 x 1/4 in.	4 1/4 x 1 1/2 x 1/4 in.
Recommended arbor speed	4300 rpm (approx.)	4300 rpm (approx.)
Motor recommended (minimum)	1/2 HP, 3450 rpm	1/2 HP, 3450
Pulleys—machine and motor	2-inch and 2 1/2-inch	2-inch and 2 1/2-inch
V-belt	1/2 x 37-inch	1/2 x 30-inch
Height x width x length	9 3/4 x 20 1/2 x 40 1/2 in.	8 x 9 x 29 1/4 in.

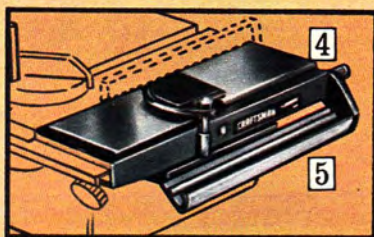

4

5

Extension Jointer-Planer converts 8-in. bench saw **\$59.99**

4 CRAFTSMAN Handy accessory for Saw, 9KT24282N, pg. 5. Uses saw motor. Planes boards to 4 in. wide. Mounts flush with forward edge of saw table. Use Tilting Fence below as added accessory.
9 KT 2184C—Shipping weight 31 lbs. \$59.99

5 Tilting Fence. Use with Extension (9 KT 2184C) above. Stops at 90° and 45°.
9 KT 2181—Shipping weight 4 lbs. 7 oz. \$14.99



Knife-setting Gauge Set

\$7.99

For use with Jointer-planers. Use to install jointer blades after sharpening. Machined cast iron gauge with micrometer adjustments for maximum accuracy. Handy touch-up stone included.
9 KT 2647—Shipping weight 1 lb. 10 oz. Set \$7.99

CRAFTSMAN® Planer-Molder for carpentry shops

- Turns hard or soft lumber into moldings, trims, floorings, etc.
- Planes and molds in a single pass or does either separately
- Planes to 12 1/4 inches wide, 6 inches thick

Without motor or stand **\$399.00**

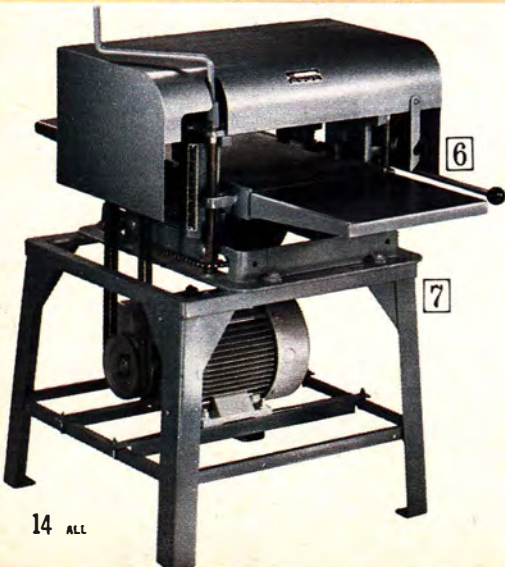

6

7

6 Power feeds at 12 feet per min. 42-in. long bed. Maximum depth of cut, 3/16-in. Three-knife ball bearing cutterhead; 3 1/2-in. diam. With 3 1/2-in. machine pulley. Face or edge mold up to 6 in. wide—order cutter bits at right. Use 1 to 5 HP motor for 4000 rpm head speed. With stand (7), takes 5-in. motor pulley and 56-in. V-belt for 2 HP 3450 rpm motor. Motor, stand, motor pulley, V-belt not incl. For planers and stand pay motor carrier or express charges from factory near Kansas City, Mo. Allow extra time. No C.O.D.'s. *Guaranteed 1 year—see page 8.* Shpg. wt. 220 lbs.
F9 KT 2339N \$399.00

Thickness Planer. As left but 18-in. bed and no molding feature.
F9 KT 23394N—Shipping wt. 201 lbs. \$379.00

7 Steel Stand for either F9 KT 2339N or F9 — 23394N. 22 1/2 in. high, 24 1/2 in. sq. bottom.
F9 KT 23395N—Shipping weight 32 lbs. \$34.99

Molding Cutter Bits.* Set of 3, each pattern. For F9 KT 2339N.
F9 KT 23311—1-inch and F9 KT 23305—3-bead
1/2-inch radius flute F9 KT 23308—Window, door stop
F9 KT 23301—Rabbet F9 KT 23304—1/4-1/2-in. qtr. round
F9 KT 23307—Glue joint F9 KT 23313—3/16-3/8-in. qtr. rnd.
F9 KT 23309—90° flute F9 KT 23303—Base mold
F9 KT 23306—Clover-leaf F9 KT 23312—3/16-in. qtr. rnd.; cove
(Shipping weight set 3 ounces) Price per set \$3.99

Tongue and Groove Molding Cutter Bits.* For F9 KT 2339N.
F9 KT 23302—Set of 6. (Shipping weight 6 oz.) Set \$7.99
*Sent postpaid from factory near Kansas City, Mo. Allow time. No C.O.D.'s.

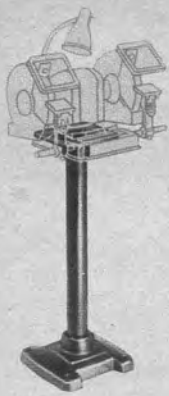

Sturdy Pedestal
\$2499

Use for CRAFTSMAN Electric grinders. Heavy-duty construction gives solid, positive support.

Sturdy 2 3/4-inch diameter tubular steel post measures 32 1/2 inches high. Cast-iron base bolts to floor (bolts not included). Pre-bored platform.

Shpg. wt. 33 lbs.
 9 KT 2964C.....\$24.99

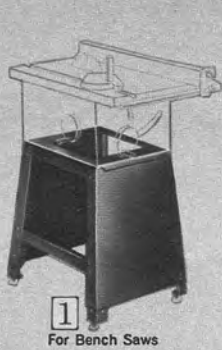

1 For Bench Saws

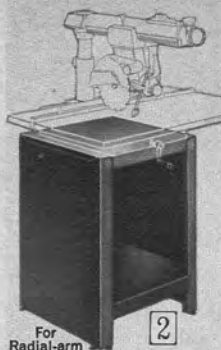

2 For Radial-arm Saws

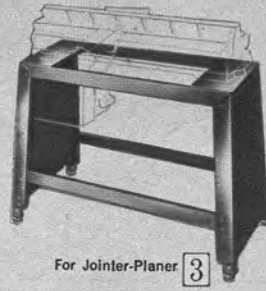

3 For Jointer-Planer



4 For Belt and Disc Sander, Wood Shaper and Band Saw

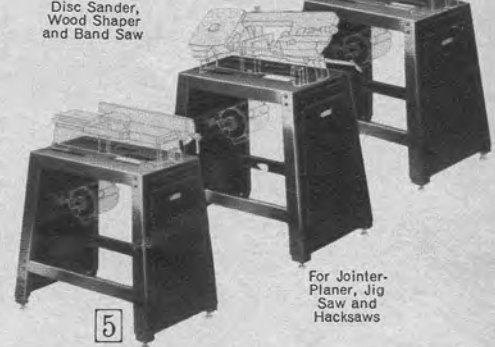

5 For Jointer-Planer, Jig Saw and Hacksaws

CRAFTSMAN® Steel Power Tool Floor Bases

Exceptionally sturdy and steady. All power tool bases with rubber-padded adjustable feet. Each base measures 32 1/2 in. high, to provide best over-all working height for power tool being used. Metal belt guards (sold separately in chart below) house V-belt from motor to power tool, prevent slippage. Sent unassembled.

Power Tool Bases				Belt Guards		
Catalog No.	Fits power tool:	Wt.	Price	Cat. No.	Shpg. wt.	Price
(1) 9 KT 2226C	10-in. Bench Saw 9 KT 2994N	27 lbs.	\$27.99	None
(2) 9 KT 1038L	8-in. Bench Saw 9 KT 24282N	52 lbs.	29.99	None
(3) 9 KT 2229N	Radial-arm Saws: 9-2943N, 9-2932N	42 lbs.	29.99	9 KT 22291	2 lbs.	\$2.99
(4) 9 KT 2224C	6 1/8-in. Jointer-Planer 9 KT 2062N	35 lbs.	29.99	None
(5) 9 KT 2223C	Belt and Disc Sander 9 KT 2254L	35 lbs.	29.99	9 KT 22242	1 lb. 15 oz.	2.99
	Wood Shaper 9 KT 2394N			9 KT 22231	1 lb. 4 oz.	2.99
	12-in. Band Saw 9 KT 2429N			9 KT 22232	1 lb. 10 oz.	2.99
	4 1/8-in. Jointer-Planer 9 KT 2186L			9 KT 22233	1 lb. 2 oz.	2.99
	Jig Saw 9 KT 2072N			9 KT 22234	1 lb. 2 oz.	2.99
	Hacksaw 9 KT 2292N					
	Hacksaw 9 KT 2294L					

CRAFTSMAN® Instruction Manuals give you dozens of new ideas for using your power tools



6 "Master Shop Guide." New... with 12 plastic-coated boards printed on both sides. Covers essential information on nails, screws, bolts, wall fasteners, lumber, moldings, plywood, etc. plus lawn care, math problems. Top board incl. ruler, protractor, 45° triangle, beam compass. Spiral bound... set up like an easel. Perforated... hangs on tool panel. Size: 8 1/4 x 11 inches.
 9 KT 2911—Shpg. wt. 10 oz.\$3.49

7 "Power Tools and how to use them." Includes 1100 illustrations of steps taken in doing 600 operations. 192 pages.
 9 KT 2912—Shipping weight 11 oz.\$1.79

8 "The Drill Press." With 200 illustrations. Covers over 100 operations. 32 pages.
 9 KT 2921—Shipping weight 2 oz.49c

9 "Bench Saws." Over 200 illustrations. Tells set up, blade selection, problems and special sawing; also for dadoing, molding and sanding. With 56 pages.
 9 KT 2929—Shipping weight 10 oz.\$3.99

10 "The Jig Saw and Band Saw." Describes short-cuts to efficient operation. More than 160 illustrations. 32 pages.
 9 KT 2919—Shipping weight 2 oz.49c

11 "The Jointer, Shaper and Thickness Planer" Instruction Book. Describes over 100 operations. Over 200 illustrations. A complete manual. 32 pages.
 9 KT 2916—Shipping weight 2 oz.49c

12 "The Wood Lathe." Over 150 operations described. Tells how to mount attachments. With 230 illustrations. 32 pages.
 9 KT 2920—Shipping weight 2 oz.49c

13 "How to Sharpen" Manual. Shows how to give almost any cutting tool a keen edge. Over 200 illustrations. 32 pages.
 9 KT 2924—Shipping weight 2 oz.49c

14 "Arc Weld it Yourself" Manual. Comprehensive training manual. Details techniques. About 100 illus. 32 pages.
 9 KT 20256—Shipping weight 5 oz.49c

15 "Metal Lathe" Manual. Shows practical operations. Illustrated. 258 pages.
 9 KT 2925—Shpg. wt. 1 lb. 4 oz.\$3.99

16 "The Oxy-Acetylene Welder's Handbook." Shows how to weld, cut, braze. For beginners and pros. 278 pgs., many illus.
 9 KT 5411—Shipping weight 10 oz.\$3.99

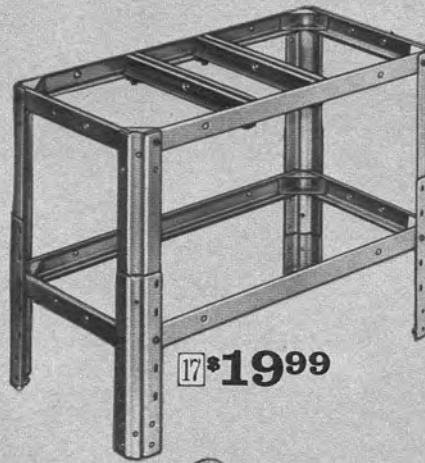

17 \$19.99

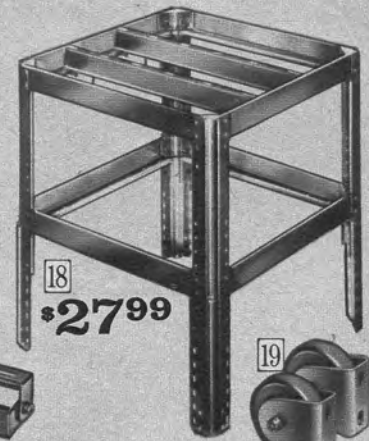

18 \$27.99

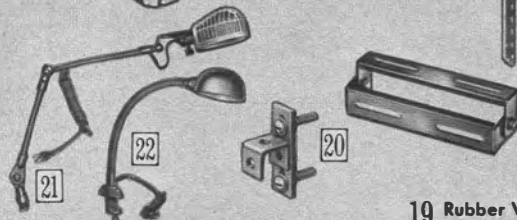

22

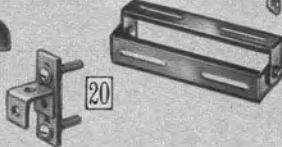

19

(17 and 18) Heavy-duty bolted steel frames. 2 steel cross-slide rails. Unassembled.

17 16 1/4 x 30-inch. Adjusts 23 1/4 to 29 3/4 in. Fits tools listed in chart below.
 9 KT 10525C—Shpg. wt. 28 lbs.\$19.99

Fits these Power Tools	Catalog No. of tool	Motor mount needed
Band Saw.....	9 KT 2429N.....1
Belt Sander.....	9 KT 2254L.....1
Bench Saw.....	9 KT 24282N.....None
.....	9-2218N.....None
Drill Press.....	9-2450.....None
.....	9 KT 2458N.....None
Hack Saw.....	9 KT 2292N.....1
Jig Saw.....	9 KT 2072N.....1
Jointer-Planer.....	9 KT 2186L.....1

18 26x26-inch. Adjusts 22 1/4 to 31 1/4 in. high. Fits following tools: Bench Saw—9 KT 2994N, 9 KT 24282N, 9 KT 2996N, 9-2218N; Shaper—9 KT 2394N; Radial-Arm Saw—9-2932N, 9 KT 2934N, 9-2935, 9-2943N, 9-2944. No motor mount needed.
 9 KT 1071C—Shpg. wt. 39 lbs.\$27.99

SHIPPING NOTE: "N" items (as 9 KT 2229N) shipped by motor carrier or express.

19 Rubber Wheels. For (17) and (18) at left. Help make it easy to move any mounted power tool. Smooth rolling hard rubber wheels resist grease. Box of 2.
 9 KT 2244—Weight 1 lb. 12 oz. . . .Box \$2.29

20 Swivel Motor Mount. For 9 KT 10525C bench at left. Maintains V-belt tension. Made of steel to keep motor vibration at a minimum. Fastens to motor base; mounts on top rail of bench or cross slide.
 9 KT 2730—Shpg. wt. 1 lb. 9 oz.\$1.99

21 Workbench Lamp. Tubular steel arm adjusts on two ball-and-socket joints and one swivel joint. Reflector with ivory-colored nylon mesh coolshield protects against burning hands. Measures 36 inches long. Incl. 6 1/2-foot cord. UL listed.
 9 KT 2504—Shpg. wt. 3 lbs. 7 oz.\$7.99

22 18-inch Bench Lamp. Can be installed on walls. Flexible gooseneck lets you direct light up, down or sideways. Interlocking socket metal shade swivels 360°. Includes 6-foot cord. UL listed.
 9 KT 2536—Shipping wt. 3 lbs.\$5.99

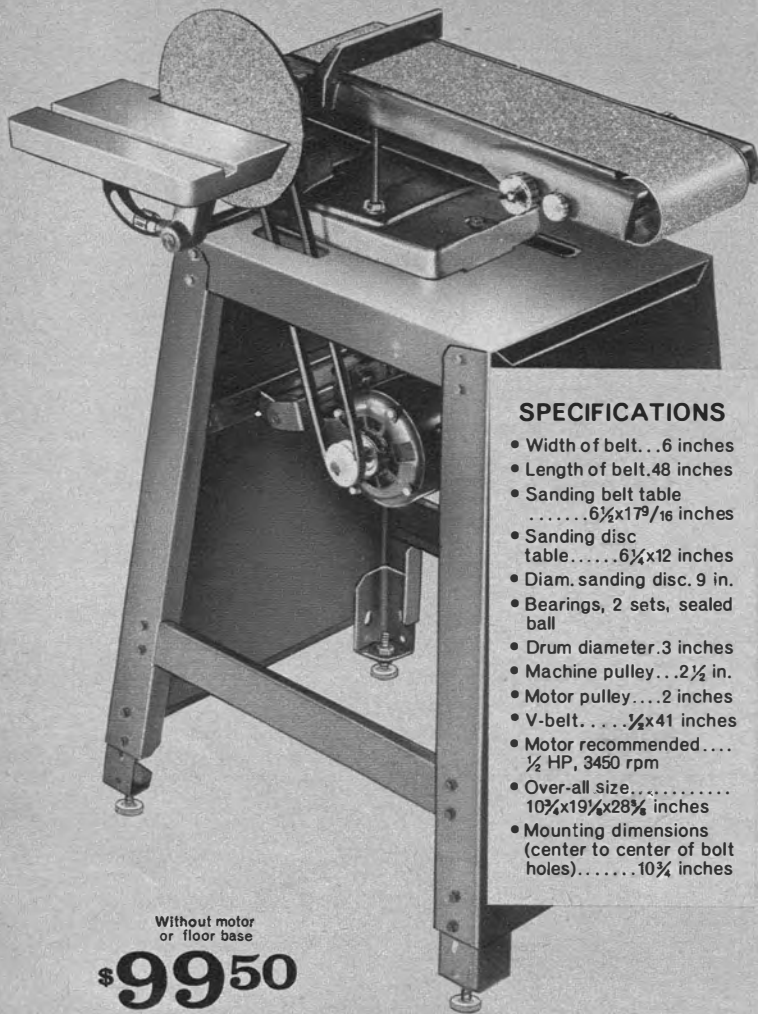

SPECIFICATIONS

- Width of belt... 6 inches
- Length of belt... 48 inches
- Sanding belt table... 6½x17⁹/₁₆ inches
- Sanding disc table... 6¼x12 inches
- Diam. sanding disc... 9 in.
- Bearings, 2 sets, sealed ball
- Drum diameter... 3 inches
- Machine pulley... 2½ in.
- Motor pulley... 2 inches
- V-belt... ½x41 inches
- Motor recommended... ½ HP, 3450 rpm
- Over-all size... 10¼x19¼x28¾ inches
- Mounting dimensions (center to center of bolt holes)... 10¾ inches

Without motor or floor base

\$99⁵⁰

CRAFTSMAN® Continuous Belt and Disc Finishing Machine

Over 100-sq. in. surface. Ideal for finishing most woods, metals, plastics and composition materials.

Great for finishing most woods, soft metals, plastics and composition materials. Surface large pieces on belt, small work on disc. Two pre-lubricated, sealed ball bearings on drive and idler shafts. Belt table tilts and locks in any position from horizontal to vertical. Two knobs on each side tension and track the belt. Work table tilts from 0 to 45 degrees. Fence adjusts from 90 to 45 degrees. Heavy cast-iron frame. (For extra accuracy, order miter-gauge 9 KT 29929 shown on page 3). V-belt included.

Without motor or Floor base.

9 KT 2254L—Shipping weight 65 pounds... \$99.50

Machine with ½-Horsepower 3450-rpm sleeve-bearing capacitor-type motor (9KT1216C). 110-120-volt, 60-cycle AC. 4-foot cord included. 9 KT 22542L2—Shipping weight 84 pounds... \$134.95

CRAFTSMAN steel Floor Base for 9 KT 2254L. See description on page 15. 9 KT 2224C—Shipping weight 34 pounds... \$29.99



SPECIFICATIONS

- Cutter height capacity... 2½ inches
- Cutter bore... ¼ inch
- Bearings... 2 sets, sealed ball
- Table surface... 8½ in. from bottom
- Miter gauge slot... ¾x¾ inches
- Length of fence... 18¾ to 21 inches
- Spindle diameter... ½-inch ends; 3/16-inch center
- Spindle adjustment... ¼ inch
- Spindle... ½-in. x 16-thread Acme
- Spindle speed suggested 9000 rpm
- Machine pulley (included)... 2 inches
- Motor pulley (incl.)... 4¾ in. flat
- V-belt... ½x33 inches
- Minimum motor... ½-HP, 3450-rpm
- Mounting dimensions... 3 holes: 2 rear are 11½ in., front is 9¼ in.
- Height 10¾ inches; width 27 inches; depth less motor guard 19 inches

Without motor or floor base

\$119⁹⁵

CRAFTSMAN® High-speed Wood Shaper

There is no end to the variety of attractive designs you can shape on the edges of your work—straight, irregular or curved. Make door, drawer and sash cuts. Features: (1) Extra-big 27x19-inch polished, ground semi-steel table. (2) Fence adjusts either side in or out without loosening. (3) Floating upper bearings for greater accuracy. (4) Built-in guard encloses belt, motor pulley for safety. (5) Collars, nuts and washers hardened to prevent burring. (6) Greater spindle diameter between bearings prevents whip and vibration. Spring hold-downs. Solid-type spindle turns either direction. 3 spindle collars. Recommended spindle speed 9000 RPM.

Without motor or Floor base.

9 KT 2394N—Shipping weight 87 pounds... \$119.95

With CRAFTSMAN ½-HP, 3450-rpm capacitor motor (9 KT 1216C).

9KT23942N2—(With 4-ft. cord. 110-120-volt, 60-cycle AC.) Wt. 106 lbs.. \$154.95

Steel Floor Base for shaper above. Description on page 15. Unassembled. 9 KT 2224C—Shipping weight 35 pounds... \$29.99

Alloy-steel Shaper Cutters

Precision machined for professional quality work. All cutters 1 inch high with ½-inch bore, except (8) 9KT3288 which is ½ inch high and (10) 9KT3287 which is ¼ inch high. For use with drill press, use with 9 KT 24832 adapter described on page 13.

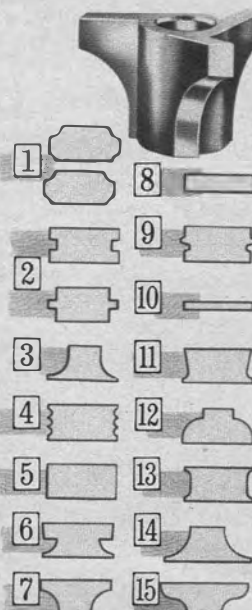

Shaper Cutter Type	Catalog Number	Wt. oz.	Price
--------------------	----------------	---------	-------

2-inch diameter Shaper Cutters			
(1) ¼ and ¼-in. radius Ease Edge or ¼-in. Glass Bead...	9 KT 3295	6	\$5.49
(2) ¼-in. Tongue and Groove Matched Set	9 KT 3283	10	9.99
(3) ½-inch Radius Base Shoe Molding or ½-in. Quarter Round...	9 KT 3285	6	5.49
(4) 3-bead ¼-in. Molding	9 KT 3293	6	5.49
(5) 1-inch Jointer...	9 KT 3289	7	5.49
(6) Lip Cupboard Door or ¾-inch Quarter Round...	9 KT 3294	6	5.49
(7) Drop Leaf Bead...	9 KT 3291	6	5.49
(8) ½-inch Groove...	9 KT 3288	5	4.49
(9) Reversible Glue Joint	9 KT 3284	6	5.49
(10) ¼-inch Groove...	9 KT 3287	4	4.49
(11) Taper Edge...	9 KT 3292	6	5.49
(12) Drop Leaf Cove...	9 KT 3290	6	5.49
(13) ¼-inch Ease Edge or Screen Molding...	9 KT 3286	6	5.49
(14) 2½-in. diameter ¾-in. Quarter Round...	9 KT 3281	6	7.19
(15) 2½-in. diameter ¾-in. Ogee Molding...	9 KT 3282	6	7.19



Sash and Door Cutting Kit

\$7¹⁹

For use with 9KT2394N upper right or former shaper 9-2392.

Kit includes: 5 spacer collars (⅜, ¼, ⅜, ½ and 1 in. wide) with ½-in. bore and sash cutter blade. 3 recessed nuts (⅜x24, ½x20 and ½x16 Acme thread). Hex key.

On drill press, use with adapter with holding collar (9 KT 24832) described on page 13. Shipping weight 8 oz. 9 KT 2407... Kit \$7.19

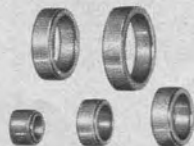

Shaper Collars

5-piece set. Use above or below cutter to provide bearing surface for portion of workpiece edge which is not to be shaped. Makes it possible to easily do freehand edge shaping of curved workpieces. Collars fit ½-inch spindle. Shipping wt. 8 oz. 9 KT 23672... Set \$3.79

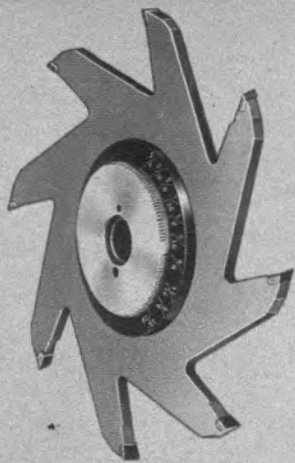

Just dial width of groove desired with
CRAFTSMAN®
SHOP-TESTED*
Adjustable Dado
***\$24.99**

Use to plough, dado, lap, groove, joint and rabbet. Precision-cut adjustable hub lets you dial width from 1/4 to 1 3/8 inch without removing dado from saw. Calibrated in 16ths of an inch. Maximum depth of cut is 2 inches. Once dado is set following cut will not vary.

Seven-inch tempered, selected tool steel blade. Eight precision-ground carbide-tipped teeth . . . bevel ground on front face for free cutting on plywood, and crosscutting on all hard and soft woods. Also use on Formica® laminated plastic, other laminates and sensitive materials. 3/8-inch arbor with 5/8-inch bushing for use on 8, 9, 10, 12 and 14-inch radial-arm and bench saws.

Not for use with 8-inch radial-arm saw 9 KT 2922N or 7 1/2-inch bench saw 9 KT 2421N.
9 KT 3267—Shipping weight 2 pounds 12 ounces. \$24.99

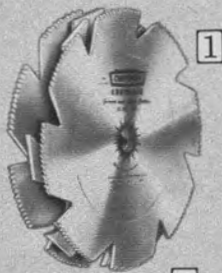

1

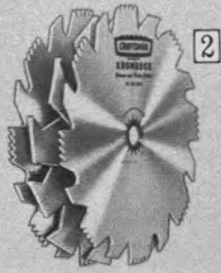

2

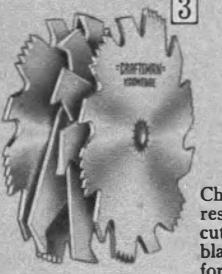

3

CRAFTSMAN®
SHOP-TESTED*
Dado sets with
Kromedge Blades

Stay sharp up to 5 times longer than ordinary blades

Chrome-nickel-moly steel . . . extra-tough, resists rust. Kromedge blades for clean cutting . . . long service. Precision-ground blades for accuracy. Matched chippers for years of smooth cutting.

1 Professional-quality satin-cut Dado Sets. Our best . . . even cut fine veneers and other sensitive materials. Also for plywood. Practically no splintering . . . straight, smooth sides. Outside cutters taper-ground for proper clearance, accurate tooth alignment. Two 1/8-inch outside cutters, four 1/8-inch chippers, one 1/16-inch chipper. For radial-arm and bench saws. Dadoes to 1 1/4 inches deep, 1 1/8 inches wide, Fits 5/8-inch round arbor.

9 KT 3257—7-inch Set. Shpg. wt. 4 lbs. 12 oz. Set \$27.99
9 KT 3253—8-inch Set. Shpg. wt. 5 lbs. 8 oz. Set 29.99

2 8-inch heavy-duty Set. For extra-tough jobs on bench, radial arm or swing saws. Includes six 1/8-inch chippers, two outside cutters 1/8 inch thick. Fits 3/8-inch round arbor. Fiber washers included for width adjustments by 1/16 inch.

Shipping weight 6 pounds 8 ounces.
9 KT 32473 Set \$26.99

3 6-inch Set. Four chippers 1/8 inch thick, one 1/16 inch thick. Two 1/8-inch thick outsidecutters. For radial-arm, benchsaws.

Fits 1/2-inch round arbor.
9 KT 3248—Shipping weight 3 pounds 2 ounces. . . . Set \$14.99
Fits 5/8-inch round arbor.
9 KT 3249—Shipping weight 3 pounds 4 ounces. . . . Set 14.99

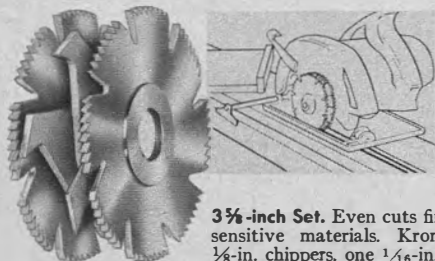

***\$12.99**

CRAFTSMAN®
SHOP-TESTED*
Dado Set for electric hand saws

3 3/8-inch Set. Even cuts fine veneers and other sensitive materials. Kromedge blades. Two 1/8-in. chippers, one 1/16-in. chipper. Two 1/8-in. outside cutters. Width of cut 1/8 to 3/16 in. Max. depth 3/16 in. Includes mounting hardware.
9 KT 3268—Shpg. wt. 1 lb. 8 oz. . . . Set \$12.99

Increased versatility for your radial arm or bench saw
CRAFTSMAN®
Molding Heads
Kromedge® bits stay sharp up to 5 times longer than ordinary cutters



SHOP-TESTED* Three-cutter Head for fastest and smoothest work

4 3/4-in. cutting diam. Best for 8, 9, 10-in. saws. Not for use with 8-in. radial saw 9 KT 2922N or 7 1/2-in. bench saw 9 KT 2421N.

21-piece Set. Incl. bits (six 3-piece sets) to cut patterns A through F below, wrench, spacer-washer, bushings, instructions and plastic case. Fits 1/2, 5/8 or 3/4-inch round arbors.
9 KT 3221—Shipping weight 2 lbs. 4 oz. Set \$19.99

Cutter-head only. As above, but without bits (bits below).
9 KT 3200—Shipping weight 1 lb. 7 oz. \$6.99

7-in. cutting diam. For 10, 12-in. radial and bench saws.

27-piece Set. With 24 bits (eight 3-piece sets) to cut patterns A through H below. Wrench, space-washer, bushing and plastic case. Fits 5/8 and 3/4-in. round arbors.
9 KT 3217—Shipping weight 4 lbs. 3 oz. Set \$29.99

Cutter-head only. As above but without bits (bits below).
9 KT 3214—Shipping weight 2 lbs. 10 oz. \$8.19

Kromedge Cutter-bit Sets, Tool steel, 3 in each set.

Illus.	Cat. No.	Type of cut (all bits 1 inch wide)	Wt.	Set
(A)	9KT2353	Cabinet Door Lip.	4 oz.	\$3.19
(B)	9KT2355	Base Molding.	4 oz.	3.19
(C)	9KT3201	Glue Joint.	5 oz.	3.19
(D)	9KT2352	3 bead (1/4 inch each).	5 oz.	3.19
(E)	9KT3212	3/4-inch Cove and Bead.	5 oz.	3.19
(F)	9KT2302	1-inch Planer and Joiner.	5 oz.	3.19
(G)	9KT3211	Window Sash.	5 oz.	3.19
(H)	9KT3204	90° Flute.	4 oz.	3.19
(J)	9KT2351	1/4-inch and 1/2-inch Quarter Round.	5 oz.	3.19
(K)	9KT3206	1-inch Flute (1/4-inch radius).	5 oz.	3.19
(L)	9KT3207	5/16-in. Qtr.Rd. 5/16-in. Cove (DropLeaf).	5 oz.	3.19
(M)	9KT3208	3/16-in., 3/8-in. Quarter Round; 1/4-in. Bead.	4 oz.	3.19
(N)	9KT2354	Clover Leaf and Screen Mold.	4 oz.	3.19
(P)	9KT3202	"Ogee" Window and Door Stop.	4 oz.	3.19
(R)	9KT3203	1/4-inch Flute and 1/2-inch Cove.	4 oz.	3.19
(S)	9KT3209	3/8-inch Cove.	4 oz.	3.19
(T)	9KT3210	Panel Cupboard Door.	5 oz.	3.19
(V)	9KT3213	Cupboard Door Rail End.	5 oz.	3.19
(W)	9KT3203	Tongue-Groove. Has 6 bits.	7 oz.	5.99

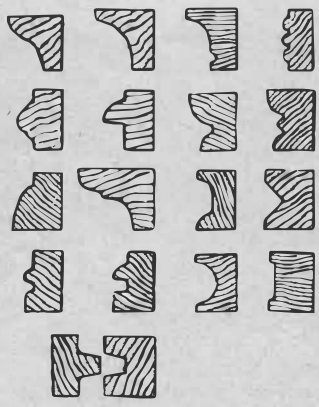
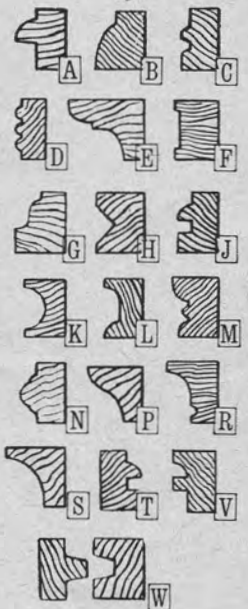

CRAFTSMAN® SHOP-TESTED* single-cutter Molding Head Set for bench, radial-arm saws . . . Kromedge Bits

21-piece set ***\$24.99**

5 1/2-inch cutting diameter . . . best for 9 and 10-inch saws

Includes 18 single bits which permit you to make 18 different designs of trim, molding and joints (see designs above). You can also use bits in combination to make many more designs.

This set is designed for Sears radial-arm and bench saws, but it will also fit other saws with 1/2 or 5/8-inch arbor.

Bits can't turn in cutter head . . . stay in perfect alignment at all times. Smooth cutting; turns out trim or moldings uniform in shape and size.

Set includes cutter-head, 18 bits, wrench, spacer washer, bushing and instructions. Comes complete with sturdy plastic 8x8-inch storage case. Not for use with radial saw 9 KT 2922N.

9 KT 3215—Shipping weight 3 pounds. Set \$24.99

*Blades and cutters tested by the manufacturer under actual use conditions.

Kromedge® Saw Blades

Stay sharp up to 5 times longer than ordinary blades..
outlast, by far, all synthetic-coated blades

Made from extra-tough chrome-nickel-molybdenum saw steel, tempered under pressure, evenly tensioned to run true and reduce wobble to a minimum. Then blades are precision-ground for perfect balance . . . and finally hard-chrome plated to produce super-hard surfaces that resist rust, build-up of gum and pitch.

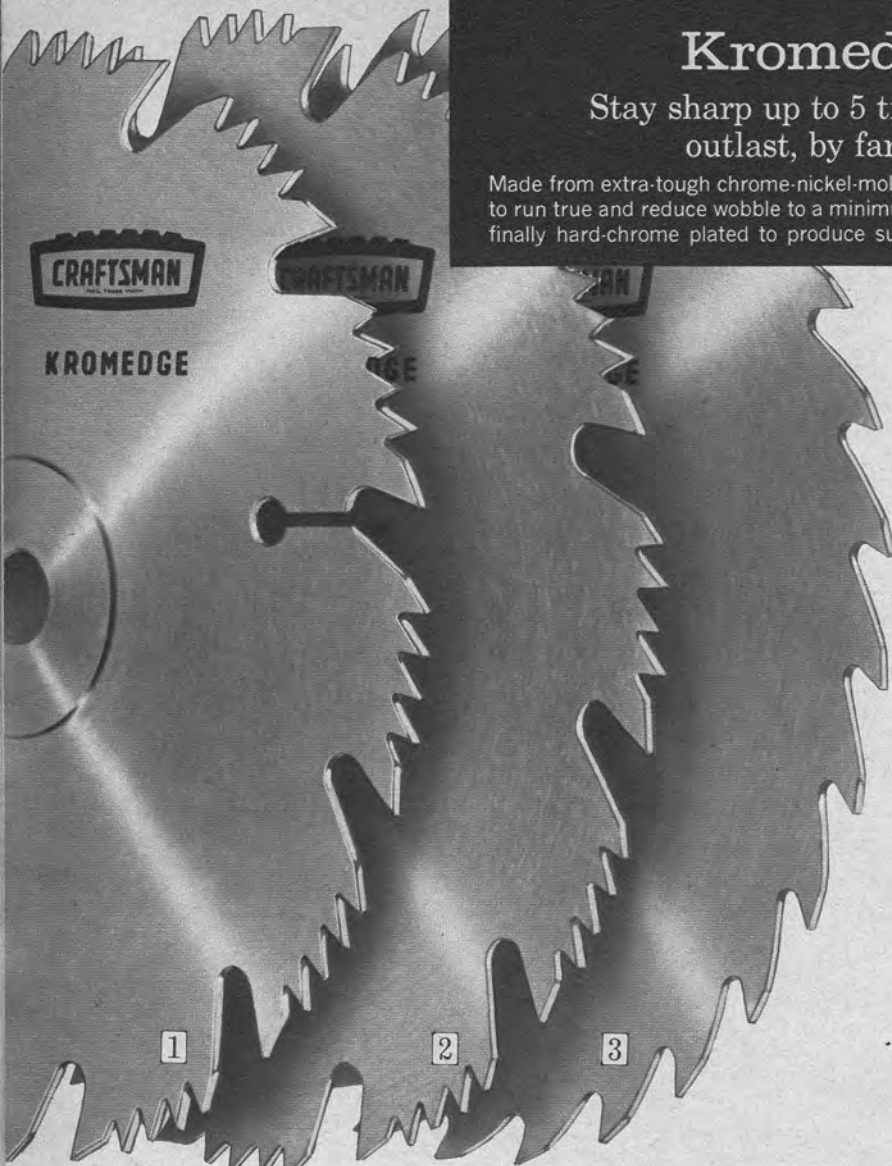

Sears exclusive "Free-Smooth Cut" and "Free-Cut" blade designs for exceptional sawing efficiency

1 "Free-Smooth Cut" Combination Blade. Deep hollow ground for freer cutting than standard. Stabilizer slots and holes give free, accurate and quiet operation even in tough wood or plastics. Prevents warping and distortion from heat.

Extra-heavy center for stability . . . helps blade give "glue-joint" cuts (need no sanding). For fine-finish woodwork, ripping, crosscutting, mitering. Teeth need no set. With $\frac{3}{8}$ - $\frac{1}{2}$ -inch hole* . . . except 10 and 12-inch with $\frac{3}{4}$ - $\frac{5}{8}$ -inch hole*.

Catalog No.	Diameter	Gauge Taper	RPM	Shpg. wt.	Price
9 KT 32641	6 in.	15-18	5080-7640	10 oz.	\$4.19
9 KT 32649	6½ in.	15-18	4700-7200	11 oz.	4.79
9 KT 32642	7 in.	15-18	4350-6550	14 oz.	5.19
9 KT 32644	8 in.	15-18	3820-5730	1 lb.	6.19
9 KT 32645	9 in.	14-17	3400-5090	1 lb. 6 oz.	8.19
9 KT 32646	10 in.	13-16	3050 4580	1 lb. 10 oz.	10.19
9 KT 32647	12 in.	12-16	2540-3820	2 lbs. 15 oz.	13.19

(2 and 3) Taper-ground and set for faster, freer, more precise cutting than most. Heavy center for great stability, true-running, minimum vibration and wobble. Tempered and tensioned.

2 "Free-cut" Combination. Crosscuts and miters. Also can be used for ripping on furniture woods and trim.

Catalog Number	Diam. inches	Gauge	Center hole, in.*	RPM	Shpg. wt. lbs. oz.	Price
9 KT 32631	6	18	$\frac{5}{8}$ - $\frac{1}{2}$	5080-7640	9	\$2.99
9 KT 32639	6½	18	$\frac{5}{8}$ - $\frac{1}{2}$	4700 7200	10	3.19
9 KT 32632	7	17	$\frac{5}{8}$ - $\frac{1}{2}$	4350-6550	12	3.29
9 KT 32633	7½	15	$\frac{5}{8}$ - $\frac{1}{2}$	4190-6140	15	3.49
9 KT 32634	8	17	$\frac{5}{8}$ - $\frac{1}{2}$	3820-5730	1	3.79
9 KT 32635	9	16	$\frac{5}{8}$ - $\frac{1}{2}$	3400-5090	1	4.39
9 KT 32636	10	16	$\frac{3}{4}$ - $\frac{5}{8}$	3050-4580	1	4.99
9 KT 32637	12	12	$\frac{3}{4}$ - $\frac{5}{8}$	2540 3820	2	6.89

3 "Free-cut" Rip-tooth.

Catalog Number	Diam. inches	Teeth	Gauge	Center hole, in.*	RPM	Shpg. wt. lbs. oz.	Price
9 KT 32629	6½	30	18	$\frac{5}{8}$ - $\frac{1}{2}$	4700-7200	11	\$3.19
9 KT 32622	7	30	18	$\frac{5}{8}$ - $\frac{1}{2}$	4350-6550	12	3.29
9 KT 32624	8	36	18	$\frac{5}{8}$ - $\frac{1}{2}$	3820-5730	1	3.79
9 KT 32625	9	36	16	$\frac{5}{8}$ - $\frac{1}{2}$	3400-5090	1	5 4.39
9 KT 32626	10	36	16	$\frac{3}{4}$ - $\frac{5}{8}$	3050-4580	1	4.99

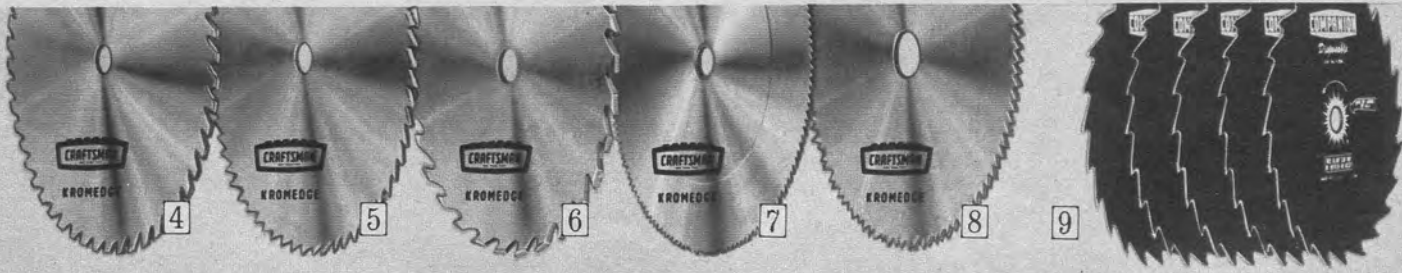

CRAFTSMAN® Shop-tested Kromedge flat-ground and thin-rim Saw Blades

4 Cabinetwork Combination. Extra-thin gauge. Almost invisible joints. No teeth marks. For 7 to 10-in. bench saws. With $\frac{3}{8}$ - $\frac{1}{2}$ -in. hole*. 6½-in. diameter. 9 KT 32431—52 teeth. Wt. 11 oz. . . . \$3.19

7-inch. With 52 teeth, $\frac{5}{8}$ - $\frac{1}{2}$ -inch hole*. 9 KT 32433—Shpg. wt. 12 oz. . . . \$3.39

8-inch. With 56 teeth, $\frac{5}{8}$ - $\frac{1}{2}$ -inch hole*. 9 KT 32432—Shpg. wt. 1 lb. 1 oz. . . . \$4.19

10-inch. With 72 teeth, $\frac{3}{4}$ - $\frac{5}{8}$ -inch hole*. 9 KT 32434—Shpg. wt. 2 lbs. . . . \$5.19

5 Flooring Saw Blades. Flat-ground. Alloy steel. For flooring, lumber salvage. Crosscuts, rips. With $\frac{3}{8}$ - $\frac{1}{2}$ -in. round center hole*. 6½-in. diameter. 64 teeth. 9 KT 32383—Shpg. wt. 10 oz. . . . \$3.29

7-inch. With 70 teeth, $\frac{5}{8}$ - $\frac{1}{2}$ -inch hole*. 9 KT 32385—Shpg. wt. 13 oz. . . . \$3.49

6 Chisel-tooth Combination. Flat-ground. Specially ground beveled teeth. Crosscuts and rips.

Catalog Number	Diam. in.	Teeth	Center hole	Shpg. wt.	Price
9 KT 32401	4	30	$\frac{1}{4}$ - $\frac{3}{8}$ in.*	4 oz.	\$1.79
9 KT 32403	5½	24	$\frac{1}{2}$ -in. round	9 oz.	2.29
9 KT 32663	6½	24	$\frac{5}{8}$ - $\frac{1}{2}$ in.*	11 oz.	2.49
9 KT 32669	7	26	$\frac{5}{8}$ - $\frac{1}{2}$ in.*	15 oz.	2.99
9 KT 32665	7½	26	$\frac{5}{8}$ - $\frac{1}{2}$ in.*	15 oz.	3.29
9 KT 32666	8	28	$\frac{5}{8}$ - $\frac{1}{2}$ in.*	1 lb. 2 oz.	3.79
9 KT 32667	9	28	$\frac{5}{8}$ - $\frac{1}{2}$ in.*	1 lb. 8 oz.	4.19
9 KT 32668	10	28	$\frac{3}{4}$ - $\frac{5}{8}$ in.*	1 lb. 13 oz.	4.79
9 KT 32702	12	24	$\frac{3}{4}$ - $\frac{5}{8}$ in.*	2 lbs. 15 oz.	5.49

7 Veneer, plywood Blade. For satin-smooth cuts. Taper-ground rim, teeth need no set. With $\frac{3}{8}$ - $\frac{1}{2}$ -inch hole*, except 10-in., $\frac{3}{4}$ - $\frac{5}{8}$ -inch hole*.

Catalog Number	Diameter	Teeth	Shipping weight	Price
9 KT 32532	6½ inches	150	12 oz.	\$4.89
9 KT 32534	7 inches	200	15 oz.	5.19
9 KT 32537	8 inches	176	1 lb. 3 oz.	6.19
9 KT 32538	9 inches	200	1 lb. 10 oz.	7.79
9 KT 32539	10 inches	200	1 lb. 13 oz.	9.19

8 Fine-tooth Crosscut Blade for plywood. Cuts Celotex, veneers, etc. For electric hand, radial-arm and bench saws. Use 4-inch for 5½-inch saw, ½-in. electric drill attachments. (9 KT 32443 with $\frac{5}{8}$ - $\frac{1}{2}$ -in. round*, ½-in. square and diamond-shaped hole.)

Catalog No.	Diameter	Teeth	Center hole	Shipping weight	Price
9 KT 32441	4 in.	100	$\frac{1}{2}$ -in. round	5 oz.	\$1.99
9 KT 32442	6½ in.	150	$\frac{5}{8}$ - $\frac{1}{2}$ in.*	10 oz.	2.59
9 KT 32443	6 in.	96	see above	10 oz.	2.29
9 KT 32445	7 in.	200	$\frac{5}{8}$ - $\frac{1}{2}$ in.*	13 oz.	2.99
9 KT 32449	7½ in.	200	$\frac{5}{8}$ - $\frac{1}{2}$ in.*	14 oz.	3.49
9 KT 32447	8 in.	176	$\frac{5}{8}$ - $\frac{1}{2}$ in.*	1 lb. 2 oz.	3.89
9 KT 32448	9 in.	200	$\frac{5}{8}$ - $\frac{1}{2}$ in.*	1 lb. 8 oz.	4.29
9 KT 32446	10 in.	200	$\frac{3}{4}$ - $\frac{5}{8}$ in.*	1 lb. 12 oz.	4.89
9 KT 32451	12 in.	200	$\frac{3}{4}$ - $\frac{5}{8}$ in.*	3 lbs.	5.79

COMPANION Disposable Blades

9 With 6½-inch diameter. Not CRAFTSMAN. For framing cuts on timbers, 2x4's, etc. Not for finish cuts, trims. Flame-hardened, high-carbon steel chisel teeth. 17-gauge tempered body. $\frac{5}{8}$ - $\frac{1}{2}$ -in. arbor. Set, beveled. Can't be reset or filed. Black oxide finish. 24 teeth. Pkg. of 5. 9 KT 3261—Shpg. wt. 2 lbs. 15 oz. . . . Pkg. \$5.19

7-inch diameter. 26 teeth. $\frac{5}{8}$ - $\frac{1}{2}$ -in. arbor. Pkg. of 4. 9 KT 3251—Shipping weight 3 lbs. 12 oz. . . . Pkg. \$5.19

*NOTE: Round center hole knockout bushed for arbor sizes listed.

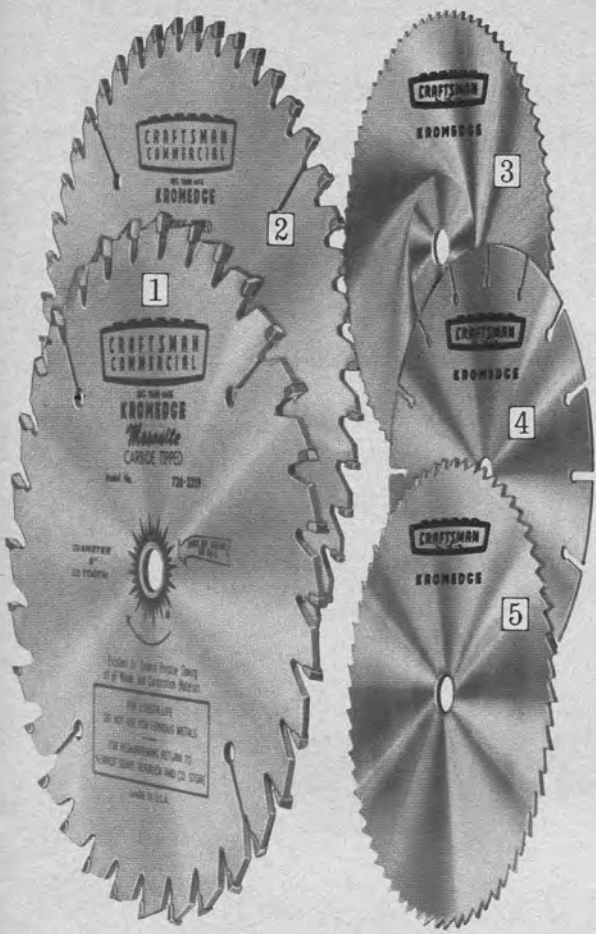

Kromedge® Blades

(1 and 2) Long-life industrial quality blades for commercial and home shop applications. Tipped with tungsten-carbide, one of the hardest-cutting man-made materials. That's why these blades cut so fast and smoothly... stay sharp so long. See the CRAFTSMAN COMMERCIAL story on page 13.

1 For cutting Masonite Presdwood®, hardboards, waterproof plywood and wood laminates. Carbide tips give you a blade that outlasts ordinary blades up to 20 times. Precision, diamond-ground teeth alternately beveled.

Catalog No.	Diameter	Center hole*	Teeth	Shipping weight	Price
9 KT 3259	8 in.	5/8-1/2 in.	32	1 lb. 13 oz.	\$39.99
9 KT 3255	10 in.	3/4-5/8 in.	40	2 lbs. 12 oz.	49.99
9 KT 32555	12 in.	3/4-5/8 in.	48	3 lbs. 6 oz.	59.99

2 Multi-purpose blade for finish cuts in nearly any material other than ferrous metals and masonry. Perfect for composition, plastics, brass, aluminum, bronze and all types of wood. Big 10-inch diameter. With 3/4-5/8-inch arbor*, 48 teeth. 9 KT 3250—Shipping weight 2 lbs. 12 oz. \$59.99

3 For copper, brass, aluminum. Specially treated for longer life; made of tempered alloy steel. (Not carbide tipped.)

Catalog No.	Diameter	Center hole*	Teeth	Shipping weight	Price
9 KT 32505	6 1/2 in.	5/8-1/2 in.	80	10 oz.	\$4.99
9 KT 32506	8 in.	5/8-1/2 in.	80	1 lb.	5.99

4 For sheet-metal roofing and iron. Wear goggles when using. Tempered alloy steel. Specially treated to resist rust for long-lasting blade life. (Not carbide tipped.)

Catalog No.	Diameter	Center hole*	Shipping weight	Price
9 KT 32507	6 1/2 in.	5/8-1/2 in.	10 ounces	\$3.79
9 KT 32503	7 in.	5/8-1/2 in.	12 ounces	3.99

5 For Masonite Presdwood, hardboard, and waterproof plywood. Tempered chrome-nickel-moly steel. Specially treated blades resist rust, prolong life. (Not carbide tipped.)

Catalog No.	Diameter	Center hole*	Teeth	Shipping weight	Price
9 KT 32583	6 1/2 in.	5/8-1/2 in.	64	12 oz.	\$3.29
9 KT 32584	7 in.	5/8-1/2 in.	70	13 oz.	3.79

*NOTE: Center hole knockout bushed for arbor sizes listed.

Cut vibration and wobble with Blade Stabilizers

For 7 to 10-in. diameter blades. Use for carbide tipped and most regular blades. With 4-in. diameter. Center hole knockout bushed for 5/8-1/2-in. arbor. Package of 2. 9 KT 4952—Shpg. wt. 1 lb. 6 oz. Pkg. \$2.99

CRAFTSMAN® CARBIDE-TIPPED BLADES

Outlast non-tipped blades 20 to 1

Tungsten carbide—one of the hardest cutting materials made by man. That's why these blades cut so fast and stay sharp so long

Low as \$819 6 1/2-inch diameter

One CRAFTSMAN carbide-tipped blade costs only a fraction of what you'd spend for non-tipped blades used in same amount of time.

Cut smoother and feed more evenly. Requires less power than most standard blades.

Kromedge blades treated to resist rust and build-up of pitch and gum. Rip, crosscut, miter and bevel. Cut woods, most plastics, Masonite Presdwood, Formica® and other laminated plastics, asbestos, thin brass, aluminum, wall-board (not for masonry or ferrous metals). Width of cut about 1/8 inch.

Catalog Number	Teeth	Diameter	Center hole*	Shipping weight	Price
9 KT 32465	8	6 1/2 inches	5/8-1/2 inch	1 pound 5 ounces	\$8.19
9 KT 32461	8	7 inches	5/8-1/2 inch	1 pound 7 ounces	8.99
9 KT 32467	8	7 1/2 inches	5/8-1/2 inch	1 pound 12 ounces	9.99
9 KT 32454	8	8 inches	5/8-1/2 inch	2 pounds 4 ounces	10.99
9 KT 32457	8	9 inches	5/8-1/2 inch	2 pounds 6 ounces	13.99
9 KT 32468	8	10 inches	3/4-5/8 inch	2 pounds 10 ounces	15.99
9 KT 32469	12	12 inches	3/4-5/8 inch	3 pounds 3 ounces	19.99

*NOTE: Round center hole knockout bushed for arbor sizes listed.

CRAFTSMAN® Circular Saw Sharpener

Only \$2199

Re-tooths... sharpens and joints

Save yourself the time and money it takes to have your circular-saw blades sharpened and reconditioned in an outside shop. This professional-type sharpener pays for itself in service charges you save.

Designed to handle all regular-blade sizes up to 12-inch diameter. With grinding wheel bushed for 1/2 and 5/8-inch arbor hole. Two index dials and safety guide for your protection. Use with bench and radial-arm saws. Bushed for 1/2, 5/8, 3/4 and 1-in. round blade holes. Instructions included. 9 KT 3532—Shipping weight 5 lbs. \$21.99

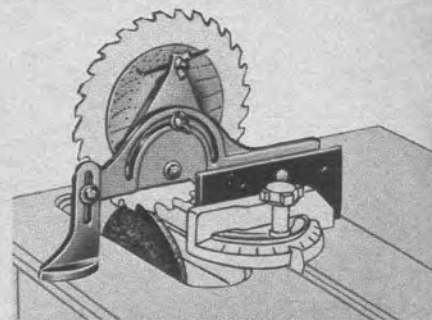

6 CRAFTSMAN Circular Saw Blade-setter Set.

Just a hammer tap sets teeth. For 4 to 12-inch blades with 1/2, 5/8, 3/4 or 1-in. center hole. Steel anvil and plungers assure long-lasting accuracy. Die-cast zinc body parts for longer life. Wrench, 4 bushings and instructions included. 9 KT 3530—Shipping weight 14 ounces. Set \$3.79

7 CRAFTSMAN Gum and Pitch Remover.

Thin coating dissolves pitch, gum on circular or band saw blades, planer, jointer knives, shaper cutters, other wood-working tools. Inhibits rust. 1 pint. 9 KT 49191—Shpg. wt. 1 lb. 7 oz. Pint 99c



CRAFTSMAN® Metal-turning Lathe

6-inch swing .16 speeds
..4 feeds. Accuracy tested
to 1/1000 of an inch

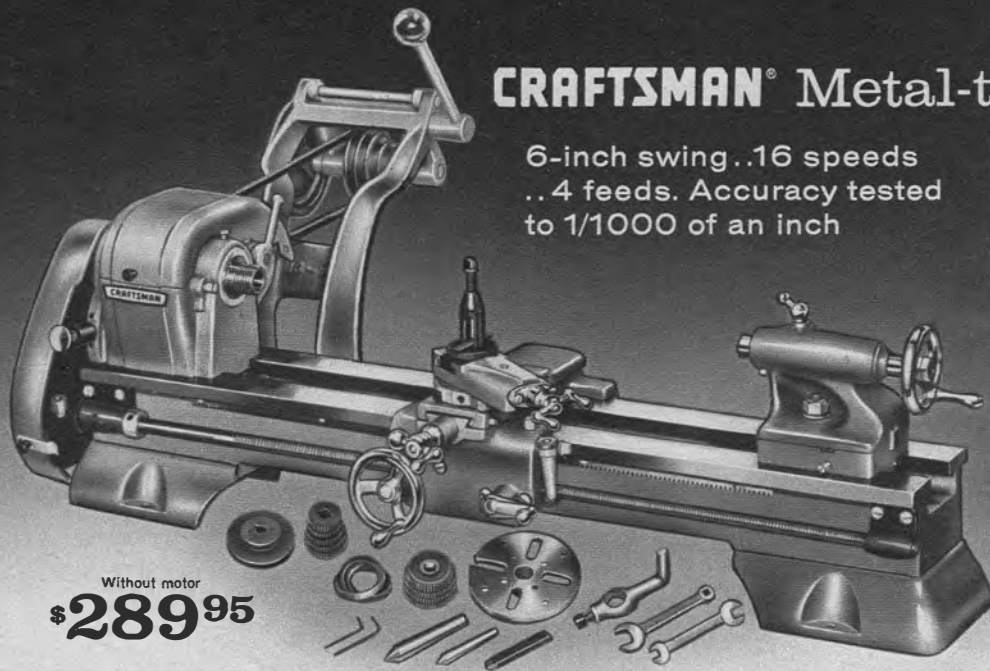

Without motor
\$289⁹⁵

It actually matches our larger lathes in accuracy. True professional quality in every detail. Designed for precision work... for toolmakers, model-makers and hobbyists who demand top-quality tools. Compare features and specifications at right with other metal-turning lathes in this price range.

Timken tapered roller bearings in headstock for long life. Cast semi-steel bed with precision-ground ways. 16 spindle speeds from 54 to 3225 rpm. Eight back-gear speeds. Graduated compound rest swivels 360°. Countershaft bench-mounted to reduce vibration; adjustable for speed changes.

Outfit includes 258-page lathe manual at right, and all accessories shown above.

Accessory group includes the following items: 2-step motor pulley, 4-step machine pulley, 4-step quick-change countershaft, two 60-degree centers, 5/8-inch tool bit, 9 threading gears, 1-inch lathe dog, 3/8-inch V-belt, two hex wrenches, 5 1/2-inch face plate and two standard-dimension wrenches, 1 combination and 1 open end.

Motor not included. Use your present motor (if at least 1/2 HP, 1725-rpm) or order motor separately from those shown on pages 30 and 31.

Lathe designed to be used with Mica Undercutter (F9 KT 1518) listed below. Also see pages 21 to 23 for additional accessories.

9 KT 2140N—Shipping weight 100 lbs. \$289.95

SPECIFICATIONS

- Swing over bed.....6 inches
- Distance between centers....18 inches
- Spindle: Nose.....1 inch x 10-thread Taper.....No. 2 Morse Bore.....1/2 inch
- Spindle bearings. Timken tapered roller
- Thread range.... .8 to 96 per inch, right or left hand. Metric threads .5 to 3mm
- Bed.....1-piece cast semi-steel
- Carriage... hand wheel for hand operation; feed lever for reversible automatic longitudinal power feed
- Feeds......0024, .0039, .0048 and .0078
- Back gear ratio.....about 6 1/2 to 1
- Countershaft, back gear bearings......4 porous bronze
- Swing over cross slide......3 3/4 inches
- Compound rest travel.....1 1/4 inches
- Cross slide travel......4 3/4 inches
- Tailstock taper.....No. 1 Morse
- Tailstock ram travel.....1 1/4 inches
- Tailstock setover......7/16 inch
- Motor needed, min....1/2-HP, 1725 rpm
- Machine pulley (included)......4 step
- Motor pulley (included)......2 step
- Mounting dimensions......4 3/4 x 27 1/4 in.
- Over-all dimensions.....16 1/2 x 24 x 33 1/2 in.

Lathe Manual

Helpful to beginner or "old timer". 258 pages of photos, drawings, machinist's tables, easy directions. Attractively paperbound with handy index tabs. 6x8 3/4 inches.

Shipping wt. 1 lb. 4 oz.
9 KT 2925..... \$3.99

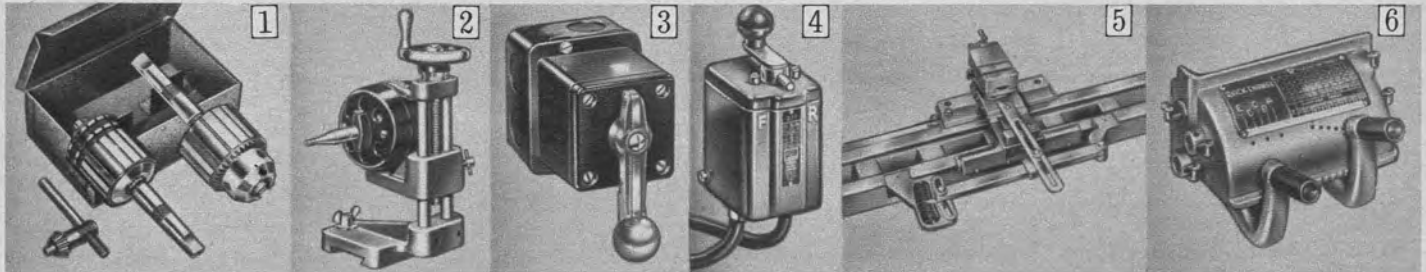

Accessories for 6-inch and 12-inch Metal-turning Lathes

1 Commutator Kit. Holds armatureshafts for reconditioning. No. 75A armature driving chuck; No. 100 center rest chuck (3/4-inch to 3/4-inch capacity); 2 arbors: No. 2 Morse, No. 3 Jacobs taper. Key.

For 12-inch lathe.
Shpg. wt. 6 lbs. 14 oz.
9 KT 2129..... Kit \$49.50

For 6-inch lathe. As above except arbors are No. 1 and No. 2 Morse taper.

Shpg. wt. 6 lbs. 3 oz.
9 KT 2122..... Kit \$49.50

2 Mica Undercutter. Screw feed regulates height of cutter. Carriage feed moves cutter into commutator slot. New grooves are always clean, square, parallel and uniform in depth. 110-120-volt, 60-cycle AC-DC. With universal motor, switch, cord, 5 undercutting saws: .015, .020, .025, .030, .035 in.

For 12-inch lathe.
F9 KT 2989—Shpg. wt. 10 lbs. \$84.95

For 6-inch. Use with 9 KT 2140N, F9 KT 1518—Shpg. wt. 9 lbs. \$84.95

Replacement Blades. Set of 10. 2 each .015, .020, .025, .030, .035 inch thick. *Sent postpaid.*
F9 KT 1519—(Wt. 2 oz.).... Set \$5.99

3 Reversing Switch. For 6, 12-in. lathes to stop, reverse split-phase and capacitor motors up to 1 HP. For voltages up to 550-v. AC. Diagram. Wt. 1 lb. 9 oz.
9 KT 2982..... \$19.95

4 Reversing Switch. For any CRAFTSMAN 12-in. lathe. 1 1/2-HP capacity for volt. to 550-v. AC. both single and 2-HP capacity 3-phase circuits. With cord, instr.
F9 KT 2018—Wt. 5 lbs. \$29.95

5 CRAFTSMAN Taper Attachment. Cuts duplicate tapers on pieces of different lengths. Also for internal boring, external work. Index plate is graduated 7°, 3 in. both sides of center line; equals 3-in. taper per foot, right or left. Use with any CRAFTSMAN 12-in. lathe. Travels 6 in. Wt. 11 lbs.
F9 KT 29845..... \$64.95

6 Quick-change Gear Attachment. Fits former CRAFTSMAN lathes 9-2758, 9-2759. S4 threads or feeds between .0042, .250-in. per spindle rev.; right or left-hand threads from 4 to 240 in standard; National Coarse (USS), National Fine (SAE), Acme, Square and Whitworth. No drilling or tapping to install. Replace std. gear change assembly. Overload clutch. Wt. 24 lbs.
F9 KT 20145..... \$149.95

SHIPPING NOTE: "F" items (as F9 KT 2989) from Kalamazoo, Michigan factory. Pay postage from c.o. plant for mailable items except 9 KT 1519. Pay motor carrier or express charges from factory for unmailable items. Allow time. No C.O.D.'s.

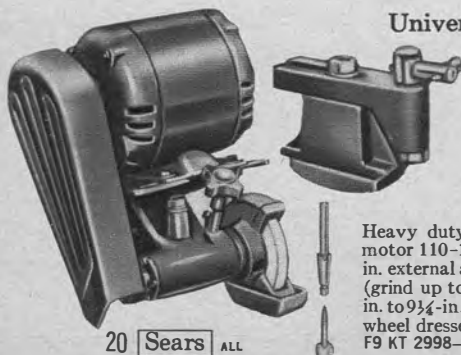

Universal Tool Post Grinder

\$179⁹⁵

For 12-in. lathes. Ideal for grinding tools, dies, bearings, shafts, valves, etc. Mounts on tool slide of lathe compound rest. Equips lathe for internal, external precision grinding. 2 speeds: 4900 and 9100 rpm.

Heavy duty spindle. With 1/2-HP 3450-rpm motor 110-120-v., 60-c. AC. Includes belt, 4-in. external and 3/2-in. internal grinding wheels (grind up to 4 1/4-in. external diam.; from 1/4-in. to 9 1/4-in. internal diameters). With diamond wheel dresser and quill for internal work.
F9 KT 2998—Shpg. wt. 37 lbs. \$179.95

CRAFTSMAN® Lathe Table

For 12-inch lathes. Gray, heavy cast iron, crossbraced legs. Can be anchored to floor. Pre-finished hardwood table top resists oil and coolants. Overall height 33 3/8 in. See Shipping Note.

For lathes 45 inches long.
Shpg. wt. 166 lbs.
F9 KT 1596N..... \$99.99

For lathes 57 inches long.
Shpg. wt. 176 lbs.
F9 KT 1597N..... \$109.00



Low as
\$99⁹⁹

**CRAFTSMAN[®]
COMMERCIAL**

Metal-turning Lathe

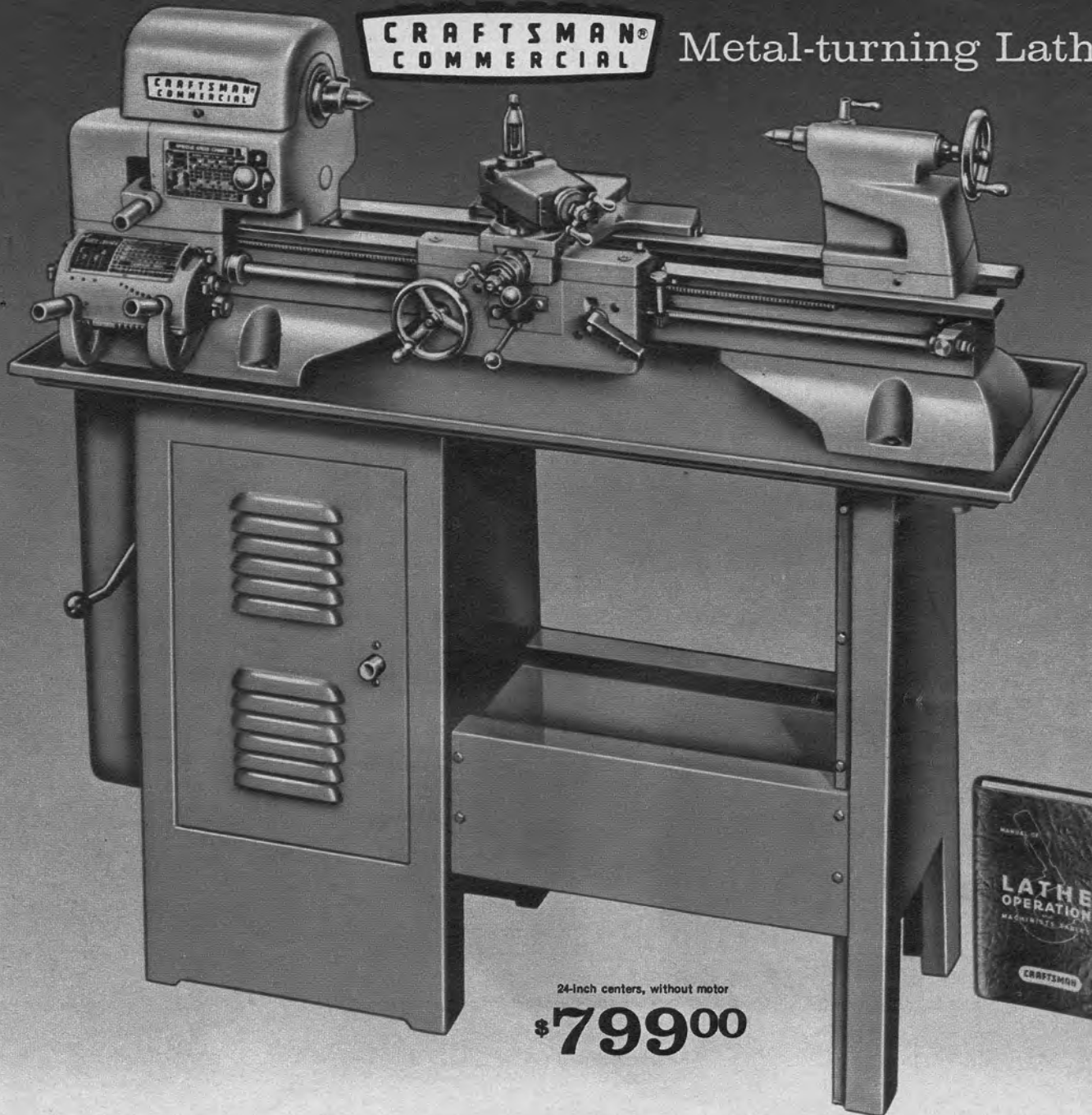

24-inch centers, without motor

\$799⁰⁰

12 $\frac{1}{4}$ -inch swing, 16 speeds, 54 feeds. Accuracy tested to 1/1000 of an inch

SPECIFICATIONS

- Swing over bed.... 12 $\frac{1}{4}$ inches
- Swing over carriage... 7 $\frac{3}{4}$ inches
- Collet capacity..... $\frac{1}{2}$ inch
- Lead Screw... $\frac{3}{4}$ -inch diameter, 8 Acme threads per inch
- Spindle Nose... 1 $\frac{1}{2}$ in. x8 thread
- Spindle Nose Taper..... Bored No. 3 Morse with reducing sleeve to No. 2 Morse
- Hole through spindle... 2 $\frac{3}{4}$ -inch
- Back Gears. 12 pitch, $\frac{3}{4}$ -in. wide
- Back Gear shaft bearings... oil-impregnated; bronze
- Back Gear Ratio... about 6 to 1
- Spindle Gear. 16 pitch, 32 teeth, $\frac{7}{8}$ -inch wide
- Spindle bearings... 2 Timken tapered roller
- Tailstock Ram... 1 $\frac{1}{2}$ -in. diam.
- Tailstock Ram travel... 2 $\frac{3}{4}$ -inches
- Tailstock Ram graduations.... 0 to 3 inches by $\frac{1}{16}$ inch
- Tailstock Setover, forward or back..... $\frac{3}{4}$ inch
- Cross feed travel... 6 $\frac{1}{2}$ inches
- Cross feed screw. $\frac{1}{2}$ -inch diameter Acme threaded
- Compound rest travel... 2 $\frac{1}{4}$ in.
- Tool Post... $\frac{3}{8}$ x $\frac{1}{2}$ -inch slot to take $\frac{3}{8}$ -in. tool bits or holder for $\frac{1}{4}$ -in. tool bits
- Compound Rest swivel. Graduated 0° to 90° right and left
- Motor recommended (min.) $\frac{1}{2}$ HP 1725 rpm
- Motor pulley (incl.) 2-step, 4 $\frac{1}{2}$ in.
- Countershaft bearings... 2 ball; 2 bronze, oil-impregnated
- V-belt.... A section $\frac{1}{2}$ -in. wide
- Drive pulley (incl.) dual, 3-inches

Quick-change gear attachment included... gives 54 threads or feeds. 16 spindle speeds from 28 to 2072 rpm. Heavy Timken roller bearings in headstock maintain spindle alignment... minimize friction. Leadscrew turns on roller thrust bearings for smoother action. Feed-engagement for power cross and longitudinal feeds lever-controlled... to engage and disengage faster.

One-spot apron lubrication system. Cross-feed and toolpost slide dials with lock screws for accurate setting. 60-hole index on headstock. Cast semi-steel bed; precision-ground ways. 7 $\frac{3}{4}$ -inch swing over carriage, 12 $\frac{1}{4}$ -in. swing over bed. Spindle nose has 2 $\frac{3}{4}$ -inch bore. 1 $\frac{1}{2}$ -inch 8-thread spindle with No. 3 female Morse taper reduced to No. 2 $\frac{1}{2}$ -inch collet capacity.

Tailstock has No. 2 Morse taper; $\frac{3}{4}$ -inch set-over for taper turning. Comes with 4-step machine pulley, 2-step motor pulley, V-belt, two 60° centers, tool post and wrenches. 258-page illustrated manual. Use a minimum $\frac{1}{2}$ -HP, 1725-rpm motor (see motors on pages 30 and 31). Motor not included with lathes. Guaranteed 1 year. Please see page 8.

With Floor-model Cabinet. Underneath drive. $\frac{3}{16}$ -inch plate, floor-type cabinet. Countershaft and belt-tension handles extend outside of cabinet. *See Note.*
 F9 KT 2898N—24-in. centers; 50 $\frac{1}{2}$ in. long. Shpg. wt. 475 lbs.....\$799.00
 F9 KT 2899N—36-in. centers; 62 $\frac{1}{2}$ in. long. Shpg. wt. 505 lbs..... 819.00

Without Cabinet. Countershaft mounted behind headstock, free of bed. Lever release both belts at once. *See Shipping Note below.*
 F9 KT 2890N—24-in. centers; 45 in. long. Shpg. wt. 335 lbs.....\$619.00
 9 KT 2891N—36-in. centers; 57 in. long. Shpg. wt. 348 lbs..... 649.00

SHIPPING NOTE. "F" items (as F9 KT 2898N) pay motor carrier or express shipping charges from factory in Kalamazoo, Michigan. Allow extra time for delivery. No C.O.D. orders.

Multi-purpose Unimat Lathe

Versatile and accurate. Compact—14½x4x5 inches high

***149⁵⁰**



Use as lathe, miller, surface grinder, polisher-grinder, hand drill or drill press—just change attachments. Accurate to .0005-in. Weighs only 29 lbs. Handles wood, metal, plastic. Headstock mounts to cast aluminum lathe bed or on vertical column; rotates 360°, locks at any angle. Belt-driven spindle drive. 11 speeds, 900 to 7200 rpm. Develops 1/10 HP. Ball-bearing spindle—3/4-in. quill feed, spring return. 6.90-in. between centers. 3-inch swing.

Includes: 3/4-in. capacity tool post, vertical column and adapter, 1/4-inch capacity, 3-jaw Jacobs-type drill chuck, key, grinding wheel arbor, face plate, lathe dog, 2 dead centers, slotted adapter, pinion and hand lever, drive belts, Allen wrench, alignment pin, tool bit, case, manual. 110-120-v., 60-c. AC. UL listed. 1-year guarantee—see page 8. From Austria. 9 KT 2140—*Lathe only*. Shpg. wt. 29 lbs. \$149.50
9 KT 21414—*3-jaw Chuck*. Shpg. wt. 1 lb. 2 oz. 29.50
9 KT 21413—*Power Feed*. Wt. 6 lbs. 2 oz. 29.50
9 KT 21415—*Machine Vise*. Shpg. wt. 15 oz. 11.50
9 KT 21416—*Milling Table*. Wt. 2 lbs. 2 oz. 14.50
9 KT 21417—*4-jaw Chuck*. Wt. 1 lb. 2 oz. 29.50
9 KT 21418—*6-pc. Tool Bit Set*. Wt. 10 oz. Set 12.50
9 KT 21419—*Live Center*. Shpg. wt. 5 oz. 7.50

Lathe Accessories



1 Milling Attachment. Graduated swivel vise, flat block, V-block. For face-milling, cutting keyways, etc. For metal lathes 9 KT 2140N (page 20). Vise capacity 2 in. Vertical feed 1 3/4 in. Cross feed 3 3/8 in. 9 KT 2057—Shpg. wt. 8 lbs. 6 oz. \$54.95 For CRAFTSMAN 12-in. lathes. Vise capacity 2 3/4 in. Vertical feed 3 3/4 in. Cross feed 5 in. F9 KT 2987—Shpg. wt. 17 lbs. \$64.95

2 Follower Rest. Mounts back of carriage dovetail slide. For work on long slender rods. For metal lathe 9 KT 2140N, page 20. 9 KT 2042—Shpg. wt. 3 lbs. 2 oz. \$14.95 For any CRAFTSMAN 12-inch lathe. 9 KT 2988—Shpg. wt. 3 lbs. 4 oz. 16.95

3 Steady Rest. Clamps to bed ways. Has bronze jaws, hinged type. For diameters to 2 3/4 inches. For CRAFTSMAN 12-inch lathes. F9 KT 20506—Shpg. wt. 10 lbs. \$27.95

As above, but not hinged type. For diameters to 2 3/4 inches. For metal lathe 9 KT 2140N, see page 20. 9 KT 2041—Shpg. wt. 3 lbs. 2 oz. \$17.95

4 Lathe Dogs. Forged steel. For any face plate with slots. 9 KT 21831—1/4-in. Wt. 8 oz. \$2.69
9 KT 21832—3/8-in. Wt. 10 oz. 2.99
9 KT 21833—1-in. Wt. 12 oz. 3.89
9 KT 21834—1 1/2-in. Wt. 14 oz. 3.99

(5 and 6) **Face Plates.** For work which cannot be machined on center or in chuck. Fit on headstock spindle. Machined gray-iron casting; slots clamp work or drive lathe dog.

5 5 1/4-inch diameter. For lathes with 1-inch 10-thread spindle (9 KT 2140N). Has 4 slots. F9 KT 21405—Shpg. wt. 2 lbs. \$9.99

6 8 1/2-inch diameter. For 12-inch lathes, lathes with 1 1/2-inch 8-thread spindle. Has 8 slots. 9 KT 24755—Shpg. wt. 7 lbs. \$16.95

7 Boring Tool Holder. For 6-inch lathes. With clamp ring, V-block, plain block and 1/4-inch high-speed boring tool. Slots hold boring tools of 3/16, 1/4, 5/16, 3/8-inch diameter. F9 KT 1515—Wt. 1 lb. \$10.99

Same as above but for 12-in. lathes. With clamp ring (has 1 1/4-in. outside diameter, 1 1/8-in. inside diameter); V-block and plain block; 1/4-in. boring tool. Clamp ring has 3 slots—holds 3/16, 1/4, 5/16, 3/8-in. diam. tools. F9 KT 1511—Wt. 1 lb. \$9.99

Please see Shipping Note at bottom of this page

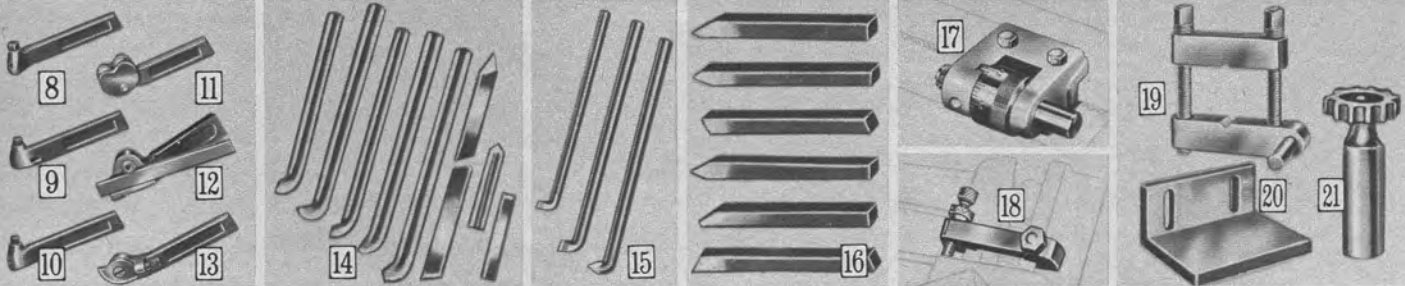

Lathe Tool Holders. Forged steel, without bit.

Type	Cat. No.	Bit size	Fits Lathe	Wt.	Each
8 Straight...	9 KT 2033	3/16-inch	9 KT 2140N.....	8 oz.	\$4.89
	9 KT 2196	1/4-inch	Craftsman 12-in. lathes	10 oz.	4.99
	9 KT 2035	3/16-inch	9 KT 2140N.....	8 oz.	4.79
9 Left hand... offset...	9 KT 2194	1/4-inch	Craftsman 12-in. lathes	10 oz.	4.99
	9 KT 2034	3/16-inch	9 KT 2140N.....	8 oz.	4.79
10 Right hand... offset...	9 KT 2192	1/4-inch	Craftsman 12-in. lathes	10 oz.	4.99
	9 KT 2036	9 KT 2140N.....	10 oz.	10.99
11 Knurling...	9 KT 2202	Craftsman 12-in. lathes	13 oz.	11.99
	9 KT 2037	9 KT 2140N.....	10 oz.	5.79
12 Cutoff...	9 KT 2200	Craftsman 12-in. lathes	12 oz.	6.49
	9 KT 2031	9 KT 2140N.....	10 oz.	9.99
13 Threading...	9 KT 2198	Craftsman 12-in. lathes	12 oz.	10.99

Replacement Blades. For cutoff tools. See (12) above. 9 KT 2238—For 9 KT 2200. Shipping weight 4 ounces.... Each \$3.29
9 KT 2009—For 9 KT 2037. Shipping weight 2 ounces.... Each 2.89

14 Tool Post Sets. 4 boring bars; internal, external, threading; external turning tools; spacer, V-block. For 9 KT 2140N. 9 KT 2038—Shipping weight 1 pound.....Set \$21.95

For any CRAFTSMAN 12-inch lathe.

9 KT 2189—Shipping weight 2 lbs. 2 oz.Set 24.99

15 Boring Tool Set. 1/4, 3/16-in. boring; 3/4-in. threading tools; spacer, V-block. For lathe 9 KT 2140N. 9 KT 2008—Shpg. wt. 4 oz. Set \$10.99

16 6-piece Formed Tool Bit Sets. Threading bit; left-hand and right-hand facing bits; left-hand, right-hand, round-nose turning bits. High-speed steel. 9 KT 2043—3/16-inch size. Wt. 5 oz. Set \$4.99
9 KT 2205—1/4-inch size. Wt. 5 oz. Set 4.99

17 Carriage Stop. Clamps to bed way of 6-inch or 12-inch lathes. F9 KT 2185—Shpg. wt. 2 lbs. \$12.49

18 Cross Slide Stop. Designed to show depth at which to stop cross feed. Slide stop is not intended to stop the cross feed automatically. To install, simply clamp the cross slide stop to dovetail. Fits 12-inch lathes. Sent *postpaid*. F9 KT 1510—(Shpg. wt. 8 oz.) \$8.99

19 Clamp-type Dog. Handles square, round, rectangular and hexagonal work. Clamp bars are carefully machined and hardened—screws are heat treated. For 12-inch and 6-inch lathes. Jaws open to 2 inches. F9 KT 1512—Shipping weight 1 lb. \$12.99

20 Angle Plate. For 12-inch and 10-inch lathes. Simplifies off-center work and the machining of odd-shaped pieces. Bolt to face plate. Horizontal face is 6x4 1/4 x 3/8 inches. Vertical face is 6x2 3/4 x 3/8 inches. F9 KT 1509—Shipping wt. 10 lbs. . \$14.99

21 Woodruff Keyway Cutters. 3/8-in. shank. *Postpaid*. (Wt. ea. 9 oz.)

Catalog No.	Diameter	Thickness	Each
F9 KT 29961	1/2 in.	3/8 in.	\$7.49
F9 KT 29962	3/4 in.	3/16 in.	7.99
F9 KT 29963	1 in.	3/4 in.	8.59
F9 KT 29964	1 1/4 in.	5/16 in.	10.99
F9 KT 29965	1 1/2 in.	3/8 in.	12.99

Shpg. Note. All "F" items (as F9 KT 2987) shipped from factory in Kalamazoo, Michigan. Allow extra time. No C.O.D.'s. Allow postage from c. o. plant unless marked "Postpaid".

Chucks, Arbors and Lathe Accessories

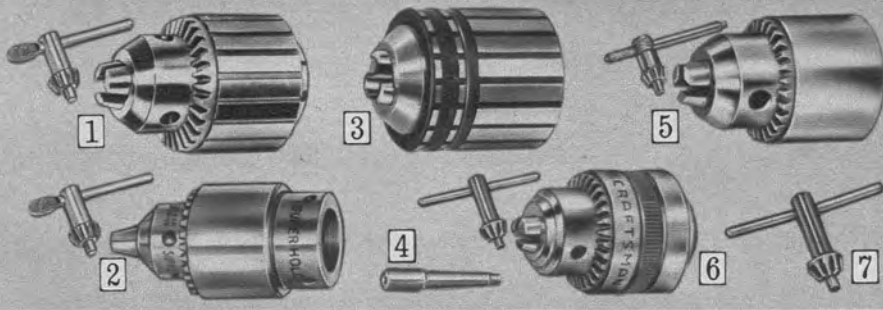

1 Geared Key Headstock Chucks. Key type. Key included.

Capacity 0 to 1/2 inch. Fits 1-in. 10-thread spindle. Do not use with arbor.

9 KT 2763—Shpg. wt. 2 lbs. 14 oz. . . . \$27.99

Capacity 1/8 to 3/8 inch. Fits 1 1/2-inch 8-thread spindle. Do not use with arbor.

9 KT 2144—Shpg. wt. 3 lbs. 2 oz. . . . \$34.99

Capacity 3/8 to 3/4 inch. Fits 1 1/2-in. 8-thread spindle. Do not use with arbor.

9 KT 2121—Shpg. wt. 4 lbs. 10 oz. . . . \$44.99

2 Lock type Chuck. For drill presses with 1 1/8-in. x 20-thread collar; No. 33 Jacobs taper. Swiveling threaded lock collar locks chuck on spindle. No special collet chucks or adapters for router, dovetailing, carving bits required. Capacity 0-1/2 inch. Key included with chuck.

9 KT 2962—Shpg. wt. 1 lb. 15 oz. . . . \$14.99

3 Center rest Chuck. Cap 1/4 to 3/4 inch. Supports centerless armatures. Must be used with No. 3 Jacobs taper arbors.

9 KT 2991—Shpg. wt. 2 lbs. 10 oz. . . . \$29.99

4 Chuck Arbors. For chuck (5) at right. No. 1 Morse and No. 33 Jacobs taper.

9 KT 2123—Shipping wt. 5 oz. . . . \$3.49

No. 2 Morse and No. 33 Jacobs taper.

9 KT 2124—Shipping wt. 8 oz. . . . \$2.69

Chuck Arbors. For chuck 9 KT 2991 (3) above and 9 KT 2129 on page 20.

No. 1 Morse and No. 3 Jacobs taper.

9 KT 2154—Shipping wt. 8 oz. . . . \$3.29

No. 2 Morse and No. 3 Jacobs taper.

9 KT 2126—Shipping wt. 9 oz. . . . 2.69

5 Drill Press Chuck. Key type, to fit No. 33 Jacobs taper. Capacity 0 to 1/2 inch. Key included.

Shipping weight 1 pound 11 ounces.

9 KT 2143 \$15.99

6 Electric Drill Chucks. With 3-jaw screw-on key type for Sears and other electric drills. Key included.

Catalog Number	Fit Threads	Capacity	Shipping weight	Price
9 KT 29721	3/8-in. x 24	1/4 to 1/2 in.	8 oz.	\$3.99
9 KT 2975	3/8-in. x 24	1/4 to 3/8 in.	15 oz.	5.49
9 KT 2980	1/2-in. x 20	3/4 to 1/2 in.	1 lb.	6.99

7 Chuck Keys. Fits Jacobs, Supreme or Sears chucks for drill presses or electric drills.

Catalog Number	Fits Jacobs Chuck	Supreme Chuck	Sears Chuck	Shpg. wt.	Each
9 KT 2052	3A, 3B, 3AE, 6A, 2A, 6A33, 6B, 6AE, 3A, 3AB, 14N, 633C	4B, 6D, 6F, 6T2, 6T6, 6T33, 6T33C, 8F, 8T3, 8D	9 KT 2143, 9 KT 2962	10 oz.	\$1.09
9 KT 2054	11N, 32, 33	3A, 3T2, 5A, 5T33, 15T33, 22T2	9-2142	7 oz.	79c

For Electric Drills:					
9 KT 2051	11A, 1B, 1BS, 1A, 1T1	9-2972	4 oz.	59c	
9 KT 2073	7, 7B, 7-1A	H17A, 4A, 4B, 4C, 4T1, 4T2	9-2979, 9-2976	7 oz.	69c
9 KT 2058	MC1, MC2, U4G	B1A, B80A, BMI A, S80A	9 KT 2975, 9 KT 2972I	4 oz.	49c
9 KT 2059	MC4K6I	B13A, B14T33, 814B, B16B, 816A, B16T33	9-2973, 9 KT 2980	4 oz.	69c
9 KT 2149	30, 30B	H13A, H13C, 7A, 7B, 7T1, 7T2		4 oz.	79c
9 KT 2054	32B, 33B, 33C	3B, 5B, 5D		7 oz.	79c

SHPG. NOTE: "F" items (as F9 KT 21408) from Kalamazoo, Mich. Allow postage from C.O. plant unless marked "Postpaid." Allow extra time for shipment. No C.O.D. orders.

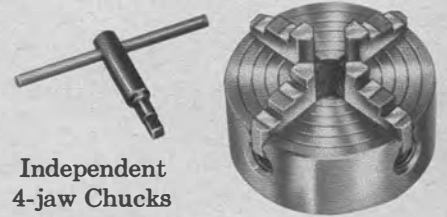

Independent 4-jaw Chucks

CRAFTSMAN®. Precision-made to assure accuracy of performance. Body of chuck of semi-steel casting with deep jaw slots for great strength and bearing surface. All four reversible jaws work independently. Especially useful for holding irregularly shaped pieces. Large jaw screw. T-handle wrench. Will fit lathe spindles as indicated below. Made in England.

Catalog No.	Will fit spindle	Diam.	Shpg. wt.	Each
9 KT 2155	3/4 inch by 16 thread	4 in.	4 lbs.	\$42.99
9 KT 2159	1 inch by 10 thread	4 in.	3 lbs. 14 oz.	39.99
9 KT 2150	1 1/2 inch by 8 thread	6 in.	10 lbs.	62.99
9 KT 21581	1 1/2 inch by 8 thread	8 in.	14 lbs.	74.99

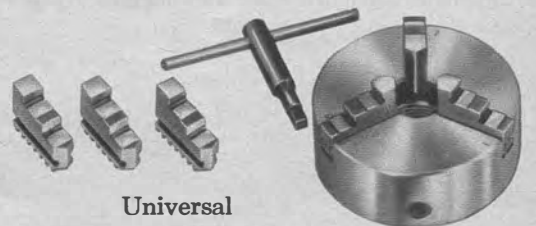

Universal 3-jaw Lathe Chucks

CRAFTSMAN. Fine quality. Heavy-duty self-centering type. Jaws controlled by single screw and pinion gear. Perfect for centering work. Body casting of semi-steel. Alloy metal scroll, alloy steel pinion. Alloy steel jaws heat-treated and hardened, feature raised steps. With inside and outside gripping jaws. T-handle chuck wrench. Will fit lathe spindles as indicated below. Made in England.

Catalog No.	Will fit spindle	Diam.	Shpg. wt.	Each
9 KT 21407	1 inch by 10 thread	4 in.	5 lbs. 8 oz.	\$64.99
9 KT 2165	1 1/2 inch by 8 thread	5 in.	9 lbs.	74.99
9 KT 2168	1 1/2 inch by 8 thread	6 in.	12 lbs. 2 oz.	94.99

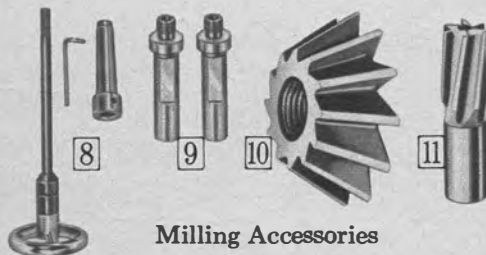

Milling Accessories

8 Milling Cutter Holder. 1/2-inch arbor included. For lathe 9 KT 2140N only, page 20.

F9 KT 21408—Shipping weight 2 pounds. . . . \$14.99

For CRAFTSMAN 12-inch lathes.

F9 KT 29945—Shipping weight 3 pounds. . . . 19.99

Four Bushings. For use with 1/4, 5/16, 3/8 and 7/16-in. end mills. 4 in set. Postpaid.

F9 KT 2985—(Shipping weight 8 ounces) . . . Set \$4.99

9 Arbors for milling cutter holder (8). Needed to adapt angular cutters. Postpaid. (Wt. 3 oz.)

F9 KT 1566—For 3/8-in. x 24-thread cutter. . . . \$4.99

F9 KT 1567—For 1/2-in. x 20-thread cutter. . . . 4.99

10 Angular Cutters. For face milling, dovetailing cuts angles less than 90°. Included angle—60°. Threaded hole adapted to fit milling holder (8)

F9 KT 29945 or F9 KT 21408 above with arbors (9)

F9 KT 1566, F9 KT 1567, above. Sent postpaid.

3/8 inch thick (1 1/4-in. diam. 3/8-in. x 24-thread hole.)

F9 KT 29951—(Shpg. wt. 9 oz.) . . . \$18.99

1/2-inch thick (1 3/8-in. diam. 1/2-in. x 20-thread hole.)

F9 KT 29952—(Shpg. wt. 9 oz.) . . . \$19.99

11 R.H. Spiral End Mills. For slots. Held in milling holder F9KT29945 or F9KT21408 with bushing 9 KT 2985, see (8). Postpaid. (Shpg. wt. each 9 oz.)

Catalog Number	Diameter	Length flute	Each
F9 KT 29971	1/4 in.	3/8 in.	\$5.69
F9 KT 29972	5/16 in.	11/16 in.	5.89
F9 KT 29973	3/8 in.	3/4 in.	5.99
F9 KT 29974	7/16 in.	7/8 in.	6.19
F9 KT 29975	1/2 in.	1 1/16 in.	6.49

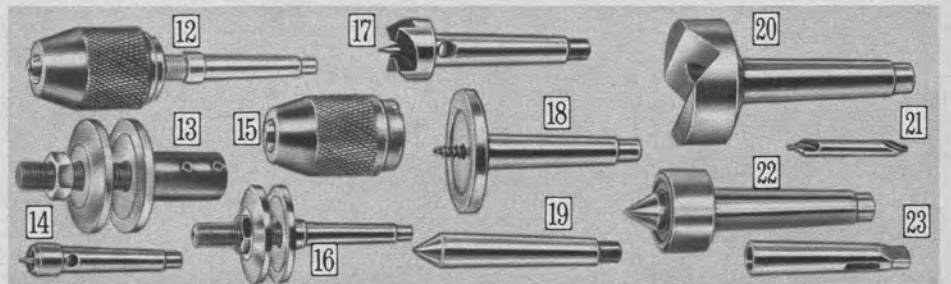

12 Work Arbors with Chuck. Rugged 3-jaw screw-on type. 1/2-inch capacity; 1 1/2-inch x 20-thread. Morse taper on arbor's shank end.

9 KT 22342—No. 1 Morse taper. Wt. 1 lb. 8 oz. \$4.99

9 KT 22472—No. 2 Morse taper. Wt. 1 lb. 10 oz. . . . 5.29

13 Work Arbor. Converts motor into grinder, polisher, etc. Get more use from your motor at little extra cost. 3 3/8 in. long. 2 3/8-in. spindle with 1/2-in. x 20-thread. Carbon steel. Steel flanges.

9 KT 21643—1/2-inch bore. Shpg. wt. 14 oz. . . . \$2.39

9 KT 21644—3/8-inch bore. Shpg. wt. 14 oz. . . . 2.39

14 Tailstock Cup Centers for wood turning.

9 KT 21002—No. 1 Morse taper. Wt. 5 oz. \$2.49

9 KT 21012—No. 2 Morse taper. Wt. 6 oz. . . . 2.79

15 CRAFTSMAN Keyless Chucks. Tough 3-jaw screw-on type with knurled surface for firmer grip. Fit 1/2-inch x 20-thread spindle.

9 KT 22482—1/4-in. capacity. Shpg. wt. 7 oz. . . \$1.39

9 KT 22562—1/2-in. capacity. Shpg. wt. 13 oz. . . 2.49

16 Work Arbors. Two steel flanges. Nut on head end for clamping wheels. 1/2-inch x 20-thread.

9 KT 21532—No. 1 Morse taper. Wt. 11 oz. . . . \$3.29

9 KT 21522—No. 2 Morse taper. Wt. 13 oz. . . . 3.29

17 Spur Centers. Use for wood turning.

9 KT 21062—No. 1 Morse taper. Wt. 6 oz. . . \$2.69

9 KT 21072—No. 2 Morse taper. Shpg. wt. 9 oz. 3.29

18 Screw Centers. Use for woodworking.

9 KT 21162—No. 1 Morse taper. Wt. 8 oz. . . 2.99

9 KT 21152—No. 2 Morse taper. Wt. 12 oz. . . 3.29

19 60-degree Centers. Use for metal turning.

9 KT 21102—No. 1 Morse taper. Wt. 5 oz. . . \$2.19

9 KT 21112—No. 2 Morse taper. Shpg. wt. 6 oz. 2.19

20 Crotch Center. For cross drilling round work.

V-slot. Steel shank. No. 2 Morse taper.

9 KT 21142—Shipping weight 1 lb. 2 oz. . . . \$2.99

21 High-speed Center Drill. Shpg. wt. ea. 2 oz.

9 KT 20601—1/8-in. size; 1/4-in. body. . . . 1.49

9 KT 20602—3/8-in. size; 5/16-in. body. . . . 1.49

22 Precision Ball-bearing 60° Center. For hard-

wood, metal. Recommended for high speeds.

9 KT 21122—No. 1 Morse taper. Wt. 11 oz. . . \$4.49

9 KT 21132—No. 2 Morse taper. Wt. 13 oz. . . 4.49

23 Adapter Sleeve. To reduce from No. 2 Morse taper to No. 1 Morse taper.

9 KT 21612—Shipping weight 7 ounces. . . . \$4.19

CRAFTSMAN® AC Arc Welder with *exclusive color-matic* continuous control . . lets you weld like a pro every time

Just pick color-coded rod for the job, match its color with color on heat-selector by turning lever (X) . . now you're ready to weld



There's an infinite selection of heat ranges . . cam lock holds settings. Aluminum-wound transformer with fiber glass insulation permits operation at full duty cycle in more heats than any other welder we sell. Color-coding instruction manual (Y) further simplifies operation. No long hours of study required.

30 to 180 amperes

\$129⁵⁰

40 to 230 amperes

\$139⁵⁰

1 You don't have to be a technician to operate this super-simplified arc welder. Technical calculations have been converted into an easy-to-understand, easy-to-operate system—lets you do professional-quality work right off without prolonged study or training.

You can weld, cut, solder, braze, heat and bend metal . . even thaw pipes. Good for auto and farm machinery repair; construction equipment maintenance. Cabinet size: 16x16x22 1/4 inches high. Cooling fan. UL listed. With 18-ft. electrode cable, 12-ft. ground cable, cable storage hanger, input cable with plug, wall receptacle, electrode holder, ground clamp and helmet. Base can be mounted on wheels (see kit 9 KT 20481 below) for easy movement. Runs on 220-240-v., 60 c., AC.

See specification table (opposite page) for further information.

180-ampere. Max. current draw 37 amps. Primary voltage 230volts.

Shipping weight 130 pounds.
9 KT 20245N \$129.50

230-ampere. Max. current draw 55 amps.; 230-v., Higher heat, faster with larger rods than 180-amp unit.

9 KT 20125N—Wt. 130 lbs. \$139.50

2 Wheel Assembly Kit. Two 3-inch rubber tires. Fits all Sears Welders except former numbers 9-2097 and 9-20996.

9 KT 20481—Shipping weight 1 pound 14 ounces. Kit \$4.99

Cable Extension for ground or electrode cables. Long 25-foot coil and connectors. No. 2 gauge copper wire, rubber covered, insulated. Use on all CRAFTSMAN arc welders except gasoline-powered type.

9 KT 20696—Wt. 8 lbs. 2 oz. Coil \$24.99

"Arc Weld It Yourself" Manual. A 36-page illus. book details arc welding process and AC electric arc welding techniques.

9 KT 20256—Wt. 5 oz. 49c

CRAFTSMAN® ARC WELDER GUARANTEE: During the first year, we will repair the CRAFTSMAN ARC WELDER free of charge, if defective in material or workmanship. This guarantee service is available by simply returning the welder to any Sears store throughout the United States.



CRAFTSMAN®
AC Arc Welder
with 12 heats . .
60 to 180 amps

\$94⁵⁰

Rugged 180-ampere welder specifically designed for farm and shop work. Operates perfectly on REA and other rural power lines. Insulated coils and transformer guard against electrical problems. Fan cools coils . . blows away dust and dirt. With on-off switch.

UL listed. Cabinet measures 16 inches wide; 16 inches deep; 22 3/4 inches high. With 18-ft. electrode cable, 12-ft. ground cable, cable storage, hanger, wall receptacle, electrode holder, ground clamp, helmet and manual.

See Sears arc welder guarantee above, right. Also see power requirements and specifications in table on facing page.

9 KT 20781N—Shipping weight 85 pounds. \$94.50

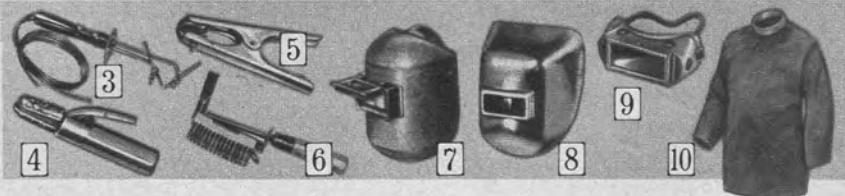

Accessories and Equipment to use with Arc Welders

3 Twin-Carbon Torch. Use with any arc welder. Produce flame similar to that of gas welding torch to braze, solder, heat metals for bending. With 2 cored carbons. 5-ft. cables. 15 3/4 in. long.
9 KT 20073—Wt. 4 lbs. 2 oz. \$17.99

Cored Carbons for above Torch.

Catalog Number	Size inches	Shpg wt.	Pkg. of	Per Pkg.
9 KT 2020	1/4 x 6	7 oz.	10	\$2.79
9 KT 20221	3/8 x 6	11 oz.	10	3.29

4 Electrode Rod Holder. Copper alloy construction. Big 200-ampere capacity. Asbestos jaw covers. For electrodes up to 1/4 inch. Spring adjusted.
9 KT 2071—Shpg. wt. 1 lb. \$7.99

5 Ground Clamp. Copper alloy. Use with current up to 500 amperes.
9 KT 2075—Shpg. wt. 1 lb. 6 oz. . . . \$3.79

6 Combination Wire Brush and Chipper. Tough forged steel head. Convenient quick-change holder.
9 KT 2074—Shpg. wt. 1 lb. 4 oz. . . \$4.99

Extra Brush for (6)
9 KT 2081—Shpg. wt. 6 oz. 99c

7 Industrial Fiber Glass Helmet. Ratchet-type head adjustment. With slide-in, lift-front plate holder. Order filter plate and cover glass below.

9 KT 1325—Helmet only. Wt. 2 lbs. 10 oz. Each \$12.99
9 KT 13277—No. 10 filter plate*. Wt. 4 oz. Each 1.49
9 KT 13278—No. 12 filter plate**. Wt. 4 oz. Each 1.49

Clear Cover Lens. For (7) above. Pkg. of 5.
9 KT 13291—Shipping weight 7 ounces. Pkg.*59c

8 Economy Fiber Glass Helmet. With cover glass, lens holder and No. 10 filter lens.*
9 KT 1320—Shpg. wt. 2 lbs. 1 oz. \$3.99

9 Oxy-acetylene Welder's Goggles. Soft polyethylene material. 2x4 1/4-in. window. Shade No. 5 filter plates. Designed to fit over spectacles.
9 KT 18636—Shipping weight 9 ounces. \$4.49

Replacement Filter Plates for goggles above. Wt. 4 oz.

Catalog No.	Shade	To cut steel	To weld steel	Each
9 KT 13274	No. 4	up to 1-inch	up to 1/2-inch	\$1.49
9 KT 13275	No. 5	up to 6-inch	up to 1/2-inch	1.49
9 KT 13276	No. 6	over 6-inch	over 1/2-inch	1.49

*for up to 5/32-in. electrodes **for up to 1/4-in. electrodes

Protector plate for (9).
9 KT 13279—Package of 4. Shpg. wt. 4 oz. 99c

10 Welder's Jacket. 10-oz. cotton twill. Flame resistant. Order size larger if worn over clothing.

Medium(37-40)Wt. 1 lb. 7 oz. Large(41-44)Wt. 1 lb. 7 oz.
9 KT 13232. \$4.99 9 KT 13233. \$4.99

**Sears Has a Credit Plan
to Suit Your Needs**

See Big Book or ask for details

CRAFTSMAN® 295 ampere AC Arc Welder

Best for use on thicker steels. 24 heats—45 thru 295 amps—give higher temperatures needed for tough jobs . . . weld, braze, solder, cut, pierce, bend, harden, temper

\$224⁵⁰ helmet, electrode holder, ground clamp and manual included

Designed for heavy-duty service requiring high heats such as in maintenance shops and on the farm; also for welding cast-iron. Built-in reactance increases open circuit voltage on all heats for easier arc maintenance. Down-draft fan exhausts through cabinet bottom . . . cools double-insulated coils to keep welder operating at high efficiency. Continuous control also built-in. Fan motor permanently lubricated. Recessed panel protects controls.

Many other applications such as: *Building* tailor-made items like boats, wagons, racks, bench and table frames; *Rebuilding* farm equipment such as worn cutting edges on plow shares, sweeps, teeth on spike harrows; *Repairing* items such as garden tools, appliances, lawn equipment, gears, sprockets, wheel rims, cars, trucks, trailers, etc.

Cabinet measures 16 inches wide x 16 inches deep, 22½ inches high. Base can be mounted on wheels (see kit 9 KT 20481 on facing page) so welder can be moved easily to any point.

Operates on 30-arc volts. NEMA rated. Includes 18-ft. electrode cable, 12-ft. ground cable, electrode holder, heavy-duty ground clamp, industrial flip-front helmet and two cable hangers. Convenient hand grips in front for lifting or moving from cart to bench. See specifications below and guarantee on page 24.

9 KT 20153N—Shipping weight 155 pounds. \$224.50



BEFORE ORDERING READ THESE SPECIFICATIONS CAREFULLY

Specification Note: Check voltage, cycle, phase and capacity of your line with your electric utility company or local REA office.

Catalog Number	Prim. Volts	AC (single phase) cy.	Amperes max. input	Prim. max. short circuit	Fuses amps.	Rod sizes (inches)	Max. KVA	Max. KW	Max. open circ. secondary	Duty cycle	Power factor
9 KT 20245N	230	60	37	62 amps.	40	1/16 to 3/16	8.5	7.0	.80 volts..	↑	.72
9 KT 20125N	230	60	55	81 amps.	60	1/16 to 3/16	12.7	9.3	.80 volts..	↑	.73
9 KT 20153N	230	60	75	120 amps.	75	3/32 to 3/8	17.3	12.8	.80 volts..	↑	.75
9 KT 20781N	230	60	37	60 amps.	40	3/32 to 3/16	8.5	6.8	.80 volts..	20%	.78

†From 20% to 100% depending on heat.

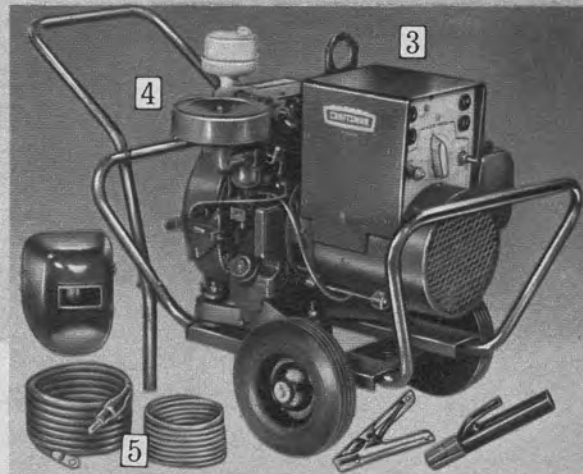

180-amp AC Welder/Generator

Buy a continuous-duty portable generator and a rugged AC welder for one low price

120-240-volt pushbutton¹ battery start without accessories

\$899⁰⁰

120-240-volt manual start without accessories

\$799⁰⁰

3 CRAFTSMAN. A 180-amp AC welder and generator capable of delivering 5000 watts of either 120 or 120/240-volt. AC current on a continuous duty basis. Powered by a 12-HP ONAN gasoline engine. Use AC power and weld at the same time. Handles 1/16 through 3/32-inch AC electrodes including low hydrogen rods and most other electrodes. Rated at 25 arc volts at 50% duty cycle. Measures 23x24x30¾ in. long. Guarantee on facing page. Pay motor carrier or express charges from factory.

Push-button battery start model.* With 120/240-volt ignition system. Mounting tray, 12-volt battery. F9 KT 20193N—Shipping weight 400 pounds. \$899.00

Manual-start models.* Rope pull starter. F9 KT 20192N—120/240-v. AC. Shpg. wt. 350 lbs. \$799.00
F9 KT 20191N—120-v. AC. Shpg. wt. 350 lbs. 699.00

4 Dolly Kit* for (3) above. Lightweight tubular steel. F9 KT 20195†—Shipping weight 20 pounds. \$89.99

5 Accessory Kit** for (3) above. With 18 foot electrode cable, 12 foot ground cable, holder, clamp. F9 KT 20196†—Shipping weight 12 pounds. \$39.00

*From factory in Minneapolis, Minn. **From factory in Paris, Tenn. †Allow extra time for factory shipment. . . . no C.O.D.'s. For mailable items (4 and 5), allow postage from catalog order plant. ALL **Sears** 25

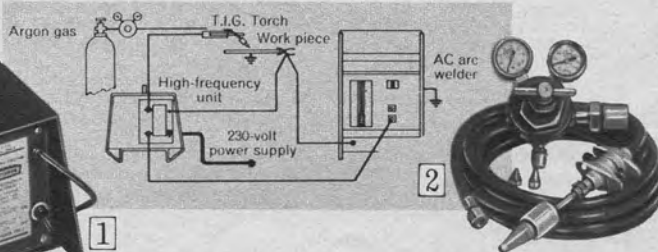

Convert your AC Arc Welder to the versatile T.I.G. (Tungsten Inert Gas) process with these units

Both units **\$149⁵⁰**

You too, can weld metals such as aluminum, bronze, nickel, stainless steel . . . also metals of very light gauge and up to ¼-inch thick. Process floods molten steel with a non-combining inert gas (usually argon)—prevents oxidation and embrittlement of weld. No preheating. 3 collets (1/16, 3/32, 1/8-inch) included. Use both units to connect AC or AC-DC arc welders.

1 Arc Stabilizer (only). For easier starts with AC or AC-DC welders in stick electrode process. 13¼x8½x9½ inches wide. Use 230-volt outlet or wire into welder circuit. Shipping weight 17 pounds.
9 KT 20993C. \$74.99

Tungsten-tip Electrodes. Shipping wt. 4 oz.
9KT20161—1/16-in. . . \$1.49
9KT20164—3/32-in. . . 1.99
9KT20166—1/8-in. . . . 2.69

Arc Stabilizer (1) and T.I.G. Torch (2). Combine for extremely fast welding on light gauge metals. Operates continuously to maintain arc. Rated for 30% duty cycle.

Arc Stabilizer provides long arc for AC units—tip need not touch metal during welding. **TIG Torch** (not sold separately) uses 1/8-inch tungsten electrode—won't pass impurities to weld. Air cooled. 200-amp. Shutoff valve, regulator hose. Insert gas not incl. (see local supplier for argon and other inert gases).
9 KT 20118C2—Wt. 22 lbs. Outfit \$149.50

CRAFTSMAN® Color-coded Contact Rods which you can weld almost like drawing on a blackboard

For arc welding. No special technical skill needed to hold an arc with CRAFTSMAN contact rods. The arc starts as soon as rod tip touches the metal to be welded. Powdered metal in the coating melts more slowly than solid metal core . . . keeps core from touching or sticking to workpiece. Coating also maintains correct arc distance from workpiece . . . makes it possible to produce a professional-like welding bead without special training.

1 Mild-steel Contact Rods. For body, fender and sheet metal work, structural steel fabrication, heavy equipment. Meets A.W.S.* Specification 6024-7024. Color-coded for identification.
9 KT 20294— $\frac{5}{16}$ x12-in. (5-lb. pkg.). Wt. 5 lbs. 8 oz. . . . Pkg. \$4.49
9 KT 20295— $\frac{3}{32}$ x12-in. (5-lb. pkg.). Wt. 5 lbs. 8 oz. . . . Pkg. 3.99
9 KT 20296— $\frac{1}{8}$ x14-in. (10-lb. pkg.). Wt. 10 lbs. 12 oz. . . . Pkg. 5.79

Pure Nickel Contact Rods. Use for cast-iron repairs (engine blocks, crankcases, valve seats) or on any gray, malleable or ductile iron. Can be machined. No A.W.S.* specifications. Color-coded.
9 KT 20272— $\frac{1}{8}$ x13 $\frac{1}{2}$ in. (1-lb. pkg.). Wt. 1 lb. 5 oz. . . . Pkg. \$4.49

Hard-surface Contact Rod. For building up hard surfaces on plowshares, scraper blades, power shovels and hitches or drive sprockets. No A.W.S.* specification. Color coded.
9 KT 20043— $\frac{1}{8}$ x14-in. (5-lb. pkg.). Wt. 5 lbs. 9 oz. . . . Pkg. \$4.49

CRAFTSMAN® Standard-type Rods

Mild-steel Production Rods for arc welding. Use to fabricate new steel products or where metal is fairly clean. Arc is stable at higher amperages needed for stepped-up welding speeds. Use in vertical or horizontal position. Meets A.W.S.* Spec. 6013. Color-coded. Comes in 10-pound package. Measures $\frac{1}{8}$ x14 inches.
9 KT 20101—Shipping weight 10 lbs. 15 oz. . . . Pkg. \$5.49

Mild-steel All-purpose Rods for arc welding. Most useful rod for repairs. Welds over rust, dirt, grease, galvanized steel or plated steel in vertical or horizontal position. Deep penetration; low slag volume. Meets A.W.S.* Spec. 6011. Color-coded.
9 KT 20011— $\frac{5}{16}$ x12-in. (5-lb. pkg.). Wt. 5 lbs. 9 oz. . . . Pkg. \$4.39
9 KT 20017— $\frac{3}{32}$ x12-in. (5-lb. pkg.). Wt. 5 lbs. 9 oz. . . . Pkg. 4.39
9 KT 20031— $\frac{1}{8}$ x14-in. (10-lb. pkg.). Wt. 10 lbs. 12 oz. . . . Pkg. 5.49
9 KT 20036— $\frac{5}{32}$ x14-in. (10-lb. pkg.). Wt. 10 lbs. 12 oz. . . . Pkg. 5.49

Cutting Rods for arc welders. Cut through all metals of any alloy. For scarfing or gauging in castings and cutting scrap. No A.W.S.* specification. Color-coded. Comes in 1-pound package.
9 KT 2028— $\frac{1}{8}$ x12-in. Shpg. wt. 1 lb. 3 oz. . . . Pkg. \$1.49
9 KT 20282— $\frac{1}{8}$ x14-in. Shpg. wt. 1 lb. 3 oz. . . . Pkg. 1.39

Professional Assortment for arc welders. In 11 sizes, types; contact, mild steel, cast-iron, hard-surfacing. In 25-lb. package.
9 KT 2047C—Shipping weight 27 pounds Package \$14.79

Special Farm-pack Assortment for arc welding. For welding tractors, cultivators, other farm implements. In 25-lb. package.
9 KT 20472C—Shipping weight 27 pounds Package \$13.99

2 Gas Rod Assortment. Over 4 lbs. (approximately 106 rods) with two 4-ounce cans of flux. For welding and brazing almost all metals. Includes approximately the following amounts of rods: four $\frac{3}{32}$ -in. aluminum; six $\frac{1}{16}$ -in. die-cast zinc; 72 copper-coated steel ($\frac{1}{16}$, $\frac{3}{32}$, $\frac{1}{8}$, $\frac{3}{16}$ -in.); four $\frac{1}{8}$ -in. cast iron; sixteen $\frac{3}{32}$, $\frac{1}{8}$ -in. bronze; four $\frac{3}{32}$ -in. flux-coated bronze. 18 inches long.
9 KT 2006—Shipping weight 5 pounds 11 ounces Package \$6.79

3 Copper-coated Gas Welding Rods. Designed especially for mild steel. $\frac{3}{32}$ -in. diameter. 18 in. long. About 140 in. pkg.
9 KT 20404—Shipping weight 5 pounds 2 oz. Package \$2.79

Gas Brazing Rods. For steel, cast iron and copper alloys.
9 KT 20452— $\frac{3}{32}$ x18 in. (pkg. of 26). Wt. 1 lb. 4 oz. Pkg. 2.99
9 KT 20454— $\frac{1}{8}$ x18 in. (pkg. of 12). Wt. 1 lb. 4 oz. Pkg. 2.99

Flux-coated Gas Brazing Rods. 1-lb. pkg. Shpg. wt. 1 lb. 4 oz.
9 KT 20464— $\frac{3}{32}$ x18 in. (about 25 in package) Package \$3.49
9 KT 20466— $\frac{1}{8}$ x18 in. (about 14 in package) Package 3.49
*A.W.S.—American Welding Society

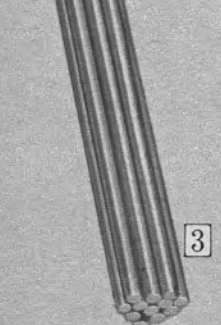
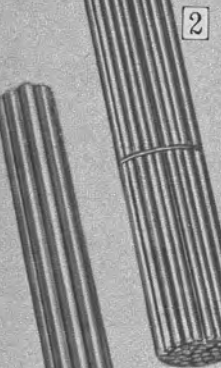
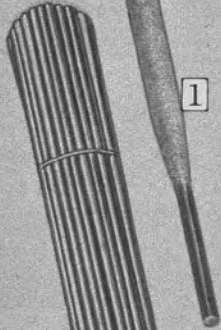
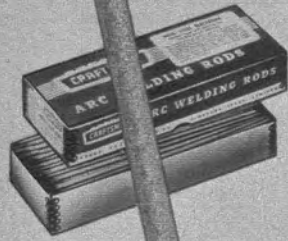

Exclusive anti-slip triangular grip

CRAFTSMAN® Single-stage light-duty Oxy-Acetylene Welding and Cutting Outfit

\$99.50

Lightweight, feathertouch 7-ounce torch for fatigue-free continuous duty. With 11-ounce cutting unit. Three welding tips: size D1 welds up to $\frac{3}{16}$ inch; size D3 welds up to $\frac{1}{8}$ inch; size D4 welds up to $\frac{1}{4}$ inch. One cutting tip (E2) cuts from $\frac{1}{8}$ inch to 1 inch.

Solid forged aluminum body. Needle shutoff valves. Stainless steel stems. Front-mounted valves. With 12 $\frac{1}{2}$ -ft., $\frac{3}{16}$ -inch diameter Siam-ez hose. Full-view vinyl mask, lighter, wrench and instructions included.

Shipping weight 16 pounds.
9 KT 54122C Outfit \$99.50



Acetylene Outfit for light brazing and soldering

\$39.99

Use for plumbing, air conditioning, auto body work. Also heats metal. Pre-set regulator draws correct pressure from acetylene cylinder. Gauge shows tank pressure. Torch handle with valve for adjusting flame. Two tips (fine and medium flame). Includes 10-ft. hose and spark lighter. UL listed. Regulator fits standard "B" size acetylene cylinder (no oxygen tank needed).

9 KT 5419—Shpg. wt. 3 lbs. 6 oz. Set \$39.99



Carrying Case for welding outfits

\$24.99

Large steel case holds any welding outfit on these 2 pages (including hose). Holders keep all pieces secure to help prevent damage. Size: 9 $\frac{5}{8}$ x9 $\frac{5}{8}$ x24 $\frac{1}{2}$ in. long. Tools not included.

9 KT 5420C—Shpg. wt. 20 lbs. \$24.99



4

4 Handbook for oxy-acetylene welding. 278 pages.
9 KT 5411—Wt. 10 oz. \$3.99

5 12-in. Mix Chamber. Naval bronze, gooseneck type. Extends cap. of 9 KT 54224C, 9 KT 54762C, 9 KT 5474 with tips 9 KT 54417, 9 KT 54418, 9 KT 5488—Wt. 1 lb., 10 oz. \$12.50

6 Tip Cleaners. Set of nine and ten, respectively. Case.
9 KT 5425—For welding tips
9 KT 5445—For cutting tips
Shipping weight 3 oz. Set \$2.79

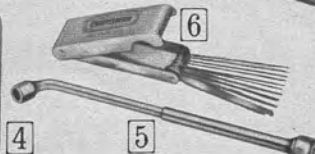

6

5

7 Tank Adapters for cylinders with right-hand male threads. For AIRCO (CGA) acetylene cylinders.

9 KT 5413—Shpg. wt. 12 oz. . . . \$2.99
For small Prest-O-Lite "B" cyls.
9 KT 5414—Shpg. wt. 12 oz. . . . \$2.99



Gas-cylinder Truck

\$24.99

Designed to hold one medium-size oxygen cylinder (122-cu. ft.) and one medium-size acetylene cylinder (145-cu. ft.). Can also be used as a regular 2-wheel truck.

Platform base 16 in. wide, 10 in. deep. Over-all truck height 40 in. All-steel construction; rust-resistant galvanized tubular frame. Shipped unassembled; bolts together (bolts and instructions included). Shipping weight 22 lbs.
9 KT 5424C \$24.99

Oxy-acetylene or Oxy-LP Gas Welders

Heavy duty production quality Welding and Cutting Outfits with long-life stainless steel valve stems. Genuine "needle type" shut-off valve . . . won't "chafe" or score

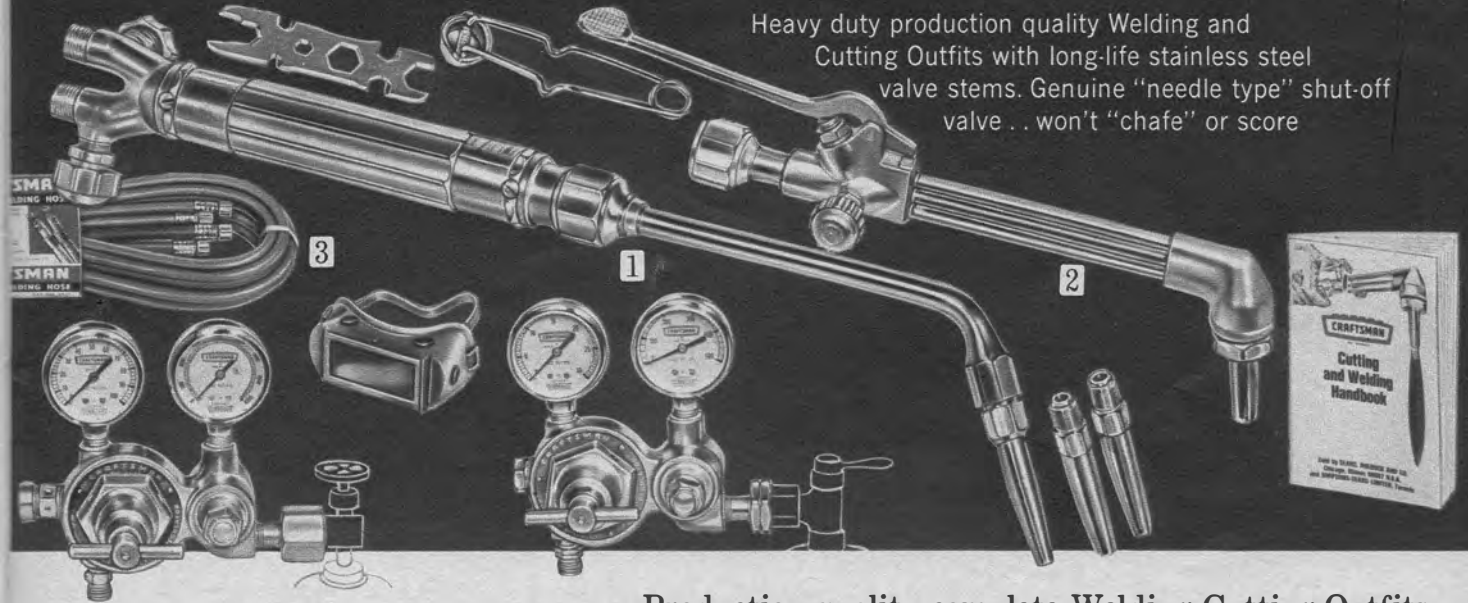

CRAFTSMAN® Production-quality Torch, Cutting Unit, Tips, Hose

1 Welding Torch. Shpg. wt. 3 lbs. 2 oz. 9 KT 5474..... \$29.99

Welding Tips. Same as in outfit 9 KT 54224C at right. Use only with welding torch (1) above. Shpg. wt. ea. 6 oz.... Ea. \$3.79

Catalog Number	Size	Capacity inches
9 KT 54419	AA-0	Use to solder
9 KT 54411	AA-1	1/8 to 1/16
9 KT 54412	AA-2	1/8 to 1/8
9 KT 54413	AA-3	1/8 to 1/16
9 KT 54414	AA-4	3/16 to 3/16
9 KT 54415	AA-5	3/16 to 1/4
9 KT 54416	AA-6	1/2 to 1/4
9 KT 54417	AA-7	1/2 to 1/2
9 KT 54418	AA-8	1 and up†

†Use only with 9 KT 5488 mixing chamber on facing page.

2 Cutting Attachment. Fits torch (1) 9 KT 5474 only. Wt. 2 lbs. 8 oz. 9 KT 5477..... \$29.99

*LP Gas means bottled propane or butane gas or mixtures of them.

Cutting Tips for (2) 9 KT 5477. For oxy-acetylene gas only. One-piece construction. Shpg. wt. ea. 7 oz.... Ea. \$5.99

Catalog No.	Size	Cuts steel
9 KT 54471	B1	Up to 1/8 in.
9 KT 54472	B2	1/8 to 1/2 in.
9 KT 54473	B3	1/2 to 1 1/2 in.
9 KT 54474	B4	1 1/2 to 3 in.
9 KT 54475	B5	3 to 6 inches

Cutting Tips for (2) 9 KT 5477. For oxy-LP* gas only. 2-pc. Shpg. wt. ea. 7 oz.... Ea. \$5.99

Catalog No.	Size	Cuts steel
9 KT 54781	BL-1	Up to 1/8 in.
9 KT 54782	BL-2	1/8 to 1/2 in.
9 KT 54783	BL-3	1/2 to 1 1/2 in.
9 KT 54784	BL-4	1 1/2 to 3 in.
9 KT 54785	BL-5	3 to 6 inches

3 Siam-eez Welding Hose. 3/4-inch inside diameter. 25 feet long. Shipping wt. 6 lbs. 7 oz. 9 KT 5427..... \$14.99

Production-quality complete Welding-Cutting Outfits



2-stage Outfit \$159.50

CRAFTSMAN® 1-stage Outfit \$129.50

- Drop forged naval-bronze goose neck on torch . . . resists bending
- Full view vinyl face mask • Three popular size welding tips
- Cutting attachment features exclusive oxygen cutting valve . . . locks in "off" position on long cuts. Tip for oxy-acetylene use included (order cutting tips for oxy-LP* gas separately at left)
- For welding, use oxy-acetylene only. Use oxy-acetylene or oxy-LP gas for cutting, brazing, heating or bending metals

Outfit with 2-stage regulators. (Includes all items shown.) First and second regulator stages maintain constant gas pressure at torch even though pressure inside the cylinder drops as gas supply lessens. Eliminates frequent adjusting . . . maintains maximum efficiency. Gauges in brass cases. Every regulator tested under pressure.

Three tips for welding steel: sizes AA-1, AA-3, AA-5; also B-3 cutting tip. See at left for capacities, and additional tips for welding steel to thickness of 1 inch and above and for cutting up to 6 inches.

All tips are uniformly swaged solid copper for accurate sizing. Individually flame tested to give proper flame pattern.

Solid brass forged torch and cutting attachment. Balanced-pressure heavy duty torch, individually flame tested . . . has non-flash mixer ahead of handle. Double "O" ring-protected channels in mixer provide leak-free connections. 25-ft. 3/4-inch diameter Siam-eez hose with solid brass fittings. Wall reinforced with tightly-braided rayon cord.

Spark lighter and combination wrench also included. Cutting and Welding Handbook. See CRAFTSMAN COMMERCIAL story on page 13. 9 KT 54224C—Wt. 27 lbs. Outfit \$159.50

Outfit with single-stage regulators (not shown). All other parts same as in outfit above. 9 KT 54762C—Wt. 26 lbs. Outfit \$129.50



CRAFTSMAN® Safety Equipment

(4 and 5) Hearing Protectors. Protects against harmful effects of noise caused by power equipment, firearms, motors, farm equipment, snowmobiles, etc. Muff-type multi-position.

4 For high noise levels. 9 KT 1868—Wt. 1 lb. . . . \$9.99

5 For moderate noise levels. Lightweight, adjustable. 9 KT 1869—Wt. 13 oz. . . . \$5.99

6 Respirator.†† Helps protect against sawdust, cement, glass, aluminum dust. Relief from allergies caused by pollen. 9 KT 1872—Wt. 5 oz. . . . \$2.99

7 Respirator†† for organic vapors, gases, paint fumes, degreasing, cleaning solvents. 9 KT 1871—Wt. 10 oz. . . . \$5.49

Filters†† for (7) 1 cartridge, 5 pre-filters. 9 KT 18762—Shpg. wt. 5 oz. Pkg. \$1.49

Respirator†† (Not shown.) For nuisance dusts: pollen, grains, cotton and wood. 9 KT 1857—Shpg. wt. 9 oz. \$4.99

Extra Filter for 9 KT 1856 above. Pkg. of 5. 9 KT 18565—Shpg. wt. 6 oz. Pkg. 99c

8 Insecticide Respirator. For dust, mist, vapor of most common insecticides. 9 KT 18571—Shpg. wt. 1 lb. 3 oz. . . . \$7.49

Replacement Filter-Cartridge for (8). 9 KT 18572—Pkg. of 2. Wt. 8 oz. . . . Pkg. \$1.99

Paint Spray Respirator. (Not shown.) For latex base paint, enamels, lacquers, epoxys, (not for use with ammonia). With cartridges. 9 KT 18573—Shpg. wt. 1 lb. 1 oz. . . . \$8.49
††Do not use as gas mask.

Repl. Cartridge for 9 KT 18573. 9 KT 18574—Pkg. of 2. Wt. 8 oz. Pkg. \$2.99

9 Flexible Mask Goggles. Wide .050-in. clear plastic lens. Fit over eyeglasses. 9 KT 1859—Shpg. wt. 7 oz. . . . \$1.59

Replacement Lens for 9 KT 1859. 9 KT 18591—Shpg. wt. 3 oz. 69c

10 Industrial Goggles. Hardened ground lenses. Adjustable frames. Side shields. 9 KT 1860—Shpg. wt. 7 oz. . . . \$2.99

Industrial Goggles. Like (10) but fit over regular glasses. 9 KT 18615—Shpg. wt. 9 oz. . . . \$3.99

11 Safety Glasses. Industrial quality. Clear and hardened lenses. Saddle-type bridge fits all noses. Shipping weight 5 ounces. 9 KT 1854 \$3.99

As (11) but with side shields. 9 KT 1855—Wt. 5 oz. . . . \$4.49

12 Face Shield. 6x11 1/4-in. window; crown deflector. Polyethylene headgear. 9 KT 18611—Wt. 15 oz. . . \$3.49

Extra Replacement Window for 9KT18611, 9KT18613. 9 KT 18612—Wt. 5 oz. . . . \$1.19

13 Face Shield. Glasses can fit behind thick 8x11 1/4-in. acetate window. Vulcanized fiber spark deflector. 9 KT 18613—Wt. 1 lb. 1 oz. \$3.99

Shield Replacement Window. For 9 KT 18613, 9 KT 18611. 9 KT 18614—Wt. 5 oz. . . . \$1.49



CRAFTSMAN® Endless-blade Hack Saw

Cuts up to 10 times faster than reciprocal type

Without motor,
base or guard **\$147⁹⁵**

SPECIFICATIONS

- Capacity of cut (maximum) . . . 3x6 in.
- Angle cuts 90° to 45°
- Bearings bronze, steel
- Machine pulley 6 inches
- Motor pulley 1½ inches
- Motor needed (minimum) . . . ½ HP
- Base size 6¼x22½ inches
- Mounting size 19⅞x5½ inches
- Blade ½ inch wide, .020 inches thick, 60 inches long, 14 teeth per inch.

Cuts through steel, cast iron, brass and aluminum. Handles any shape metal: rounds, flats, tubing, angles. Vise jaw adjusts for cuts from 90° to 45°.

Hydraulic control sets rate of blade feed. Blade speed: 135 ft./min. Nylon pinion reduces noise. With motor pulley, machine pulley (single groove, ½-inch bore) and V-belt. Use at least ½-HP, 1725-rpm motor. Order base and guard at left. Guaranteed 1 year . . . see page 8.

Saw without motor, base or guard.
9 KT 2292N—Shipping weight 76 lbs. \$147.95

Saw with CRAFTSMAN ½-HP capacitor motor (9 KT 1214C). Sleeve bearings. 1725 rpm. 110-120-v., single phase, 60-cycle, AC. 4-foot, 3-wire cord.
9 KT 2292N2—Shipping weight 97 lbs. \$184.95

Extra Blades

- For metal cutting.
Shipping wt. 6 oz.
- Ten teeth per inch. Cut over 1 inch.
9 KT 2292E—Ea. \$3.99
 - 14 teeth per inch. Cut ¼ to 1 inch.
9 KT 2292T—Ea. \$3.99
 - 24 teeth per inch. Cut up to ¼ inch.
9 KT 22929—Ea. \$3.99

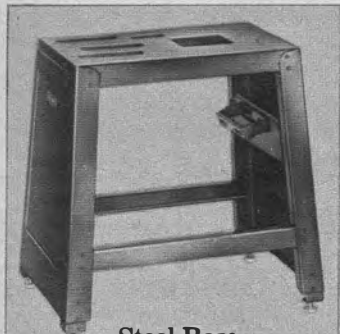

Steel Base and Steel Guards

Base **\$29⁹⁹**

Steel Base. For both hack saws. 20x30¼ in. at base. Height adjusts from 27¼ to 30¾ inches. Unassembled.
9 KT 2223C—Wt. 35 lbs.. \$29.99

Guards. (Not shown.) Enclose machine pulley and belt above table.

For 9KT 2292N. Wt. 1 lb. 2 oz.
9 KT 22233 \$2.99

For 9KT 2294L. Wt. 1 lb. 2 oz.
9 KT 22234 \$2.99

CRAFTSMAN® Reciprocal-type Hack Saw

*Semi-automatic for "hands-off"
working . . . set it and leave it*

Without motor,
stand or guard **\$109⁹⁵**

It cuts by itself . . . accurately and automatically. Blade lifts on backward stroke . . . helps prolong life of blade.

Cuts any shape of iron, brass, aluminum. Has big 4x4-inch maximum capacity to handle large work pieces. Heavy cast-iron vise locks quickly and easily . . . anchors stock solidly in place. Adjusts for angle cuts from 90° to 45°.

Cast semi-steel slide and arm with adjustable cone-type arm pivot. Takes any standard 12-inch power hack saw blade (1 included). Arm length extended is 29 inches; not extended, 26 inches. Has 5-inch stroke; operates at 60 strokes per minute at 400 rpm. With 6½-inch machine pulley, single groove, 2-inch motor pulley and ¼-inch wide x 42-inch long V-belt. Motor not included. Order base and guard at upper left. Guaranteed 1 year . . . see page 8.

Saw without motor, base or guard.
9 KT 2294L—Shipping weight 61 pounds. \$109.95

Saw with CRAFTSMAN ½-HP motor (9KT1211C). 1725 rpm split phase. Sleeve bearings. 110-120-v., 60-c. AC. 4-ft. cord.
9 KT 2294L2—Shipping weight 79 pounds \$129.50

CRAFTSMAN High-speed Hack Saw Blades. Alloy steel. ½x12 inches long. Package of 2. From Sweden.
9 KT 65888—14 teeth per inch 9 KT 65889—18 teeth per inch
Shipping weight package 5 ounces. Package \$2.29

SPECIFICATIONS

- Capacity, maximum 4x4 inches
- Angle cuts 90° to 45°
- Bearings porous bronze
- Machine pulley, single groove 6½ inches
- Motor pulley 2-inch
- Motor recommended (not included) . . . ½ HP, 1725 rpm
- Base size 6x24 inches
- Mounting size 5½x19¼ inches
- Stroke 5 inches; 60 strokes per min. at 400 rpm

CRAFTSMAN® Vacs..quickly clean any area..wet or dry

Made of Permanex™ super-tough blow-molded polyethylene. Won't crack, chip, peel or rust; resists acids, alkalis, solvents and oil. Withstands temperatures down to 20° below zero.

In addition, you get powerful and full-strength pickup from empty to full tank-container because of direct-line air flow. Debris or liquids by-pass motor, fall directly into tank-container—can't reduce suction or re-circulate through motor.

As a result, "clean", dirt-free air blows through motor fans for longer life. Guaranteed 1 year.



CRAFTSMAN® 27-gallon HOME-N-SHOP® Vac

With dolly and dry nozzle **\$69⁹⁹**

All the features of vac at right except has 3-bushel container, one by-pass motor that develops 1¼ HP (peak output) and beige Permanex tank-container is 31½ inches high, 22¾-inch diameter. Excellent for home or shop use. With 8-foot 3-wire cord, filter bags. UL listed at 120-volt, 60-cycle AC. For heavy-duty wet pickup order special wet pickup nozzle (4), below.
9 KT 17821N—Shipping weight 41 pounds.....\$69.99

GUARANTEE: During the first year, upon return, we will repair any CRAFTSMAN HOME-N-SHOP Vac, free of charge, if defective in material or workmanship. During the first 90 days, upon return, we will repair any Sears non-CRAFTSMAN brand vac, free of charge, if defective in material or workmanship.

SHIPPING NOTE: "N" items (such as 9 KT 17831N) shipped by motor carrier or express

CRAFTSMAN® 45-gallon Industrial Vac

With dolly and dry nozzle **\$99⁹⁹**

A clean sweep for schools, shops, factories . . . anywhere heavy-duty pickup action is needed. 5-bushel container. Two by-pass motors. Each develops 1¼ HP (peak output) . . . use 1 for light, 2 for heavy pickup. Sealed ball bearings. Powerful 2-stage suction or blower action. Air flow shuts off when filled with liquid. Permanex tank-container. 40½ inches high with dolly, 26¾-inch diameter. Beige color. Drain plug. Lift-off steel cover, gray enameled.

Flexible 6-ft. hose, 2½-inch diameter. Swivels 360°. Triangular nozzle. Hose, cord store on cover. Dolly with casters snaps on, off. 8-ft. 3-wire cord, filter bags. UL listed at 120-volt, 60-cycle AC.

Shipping weight 60 pounds.
9 KT 17831N.....\$99.99

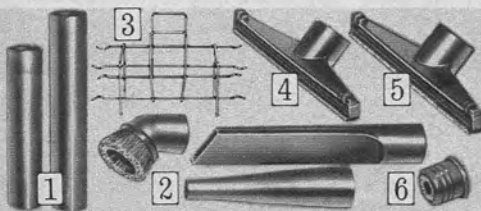

Home-N-Shop Vac

1 2-piece 46-inch Extension Handle, Plastic. Wt. 1 lb. 4 oz.
9 KT 16964.....\$4.99

2 Accessory Set, 1 blower, 1 brush, 1 crevice tool, Plastic. Shpg. wt. 1 lb. 4 oz.
9 KT 16973...Set \$4.99

3 Rack for accessories. Hang on vac or wall. Holds 7 accessories. Shpg. wt. 1 lb. 10 oz.
9 KT 17816.....\$1.99

4 Wet Nozzle. Only for vac 9 KT 17821N and vac 9 KT 17831N above. 14 in. wide. Shpg. wt. 1 lb. 3 oz.
9 KT 17817.....\$4.99

5 14-in. Dry Nozzle. Fits hose and extension handle. Made of plastic. Shpg. wt. 1 lb. 3 oz.
9 KT 16925.....\$4.99

6 Hose Adapter. Takes most standard home vac attachments. 9 KT 16966—Wt. 6 oz. \$1.99

6-ft. Hose, 2½-in. diam. Shpg. wt. 3 lbs. 4 oz.
9 KT 17818.....\$6.99

Cloth Filter Bag. Fits over and protects motor. 9 KT 16967—Wt. 4 oz. \$1.69

Paper Filter Bag. Use over cloth bag for fine dust. Pkg. of 5. Shpg. wt. 4 oz.
9 KT 16946....Pkg \$1.49



Radial Arm Saw Dust Collector

CRAFTSMAN. Cuts time needless clean-up time. Collects saw dust through 9½ x 10-inch shroud opening in rear and 1¼-inch hose from saw guard. 2½-in. reducer bushing at rear of shroud connects to any HOME-N-SHOP vac on this page. Shroud easily attaches to table as illustrated.

Effective in crosscut, rip, double cut or miter positions. Tough construction for long use. NOTE: Does not fit 9 KT 2922 Radial Saw. Shipping weight 5 pounds 6 ounces.
9 KT 16996...Kit \$14.99

CRAFTSMAN® HOME-N-SHOP Vac . . . holds 3-bushel dry load

Without dolly **\$39⁹⁹**

Similar to 9 KT 17821N but for *dry pickup only*. Single-stage motor (not by-pass) develops 1 HP (peak output). 27-gal. beige Permanex container 27 in. high, 22¾ inch diam. 8-ft. 2-wire cord. UL listed. 120-v., 60-c. AC.
9 KT 1781N—Shpg. wt. 29 lbs.....\$39.99

Steel Dolly for above. With 4 plastic casters. 9 KT 17814—Shpg. wt. 4 lbs. 2 oz.....\$6.99

Home-N-Shop Vac

Without dolly **\$29⁹⁹**

Dry pickup only. 1-stage motor (not by-pass) develops 1 HP (peak output). Rugged 8-gal. steel body for durability. 14½-inches high, 15-inch diam. 6-foot hose swivels 360°. Triangular nozzle. 6-ft. 2-wire cord. UL listed at 120-v., 60-c., AC. 90 day guarantee . . . above.
9 KT 1690C—Shpg. wt. 17 lbs.....\$29.99

Dolly for above. Steel frame, plastic casters. 9 KT 16901—Shpg. wt. 2 lbs. 1 oz.....\$4.99



CRAFTSMAN® Motors have



3450-rpm Capacitor-start for bench saws, jointer-planers, shapers, etc.

1/2-HP **\$4499**

For hard-starting high-speed tools. Rigid base mounts in any position in cradle. Knockout for BX or conduit. Quick voltage links for fast voltage changes. Mounting 3x4 3/4-inch NEMA 56 frames. Reversible rotation. Quick-connect terminals. Ground lug meets local electric codes. Double-end shaft. 3/8-inch diameter with 3/16-inch square keyway; opposite end, 1/2-inch diam., 3/8-inch deep flat. Single phase, 60-c. AC. 4-foot, 3-wire cord, adapter.

With ball bearings. Manually reset overload protector and shaft cover.

Catalog Number	HP	RPM	Volts	Shipping weight	Each
9 KT 1218C	1/2	3450	110-120 or 230	20 pounds	\$44.99
9 KT 1219C	3/4	3450	110-120 or 230	24 pounds	54.99
9 KT 1220C	1	3450	110-120 or 230	26 pounds	59.99
9 KT 1221C	1 1/2	3450	110-120 or 230	27 pounds	79.99

With sleeve bearings. No overload protector or quick voltage links.

Catalog Number	HP	RPM	Volts	Shipping wt.	Each
9 KT 1216C	1/2	3450	110-120	19 pounds	\$39.99
9 KT 1226C	3/4	3450	110-120	24 pounds	44.99
9 KT 1217C	1	3450	110-120	26 pounds	49.99

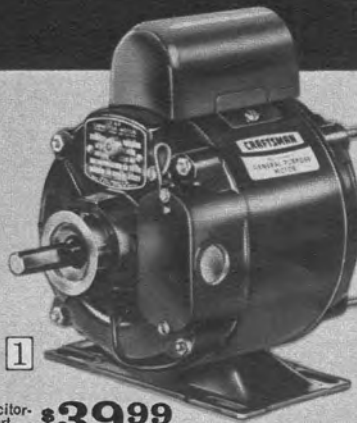

1
Capacitor-start **\$3999**
1/2-HP



2
Split-phase **\$2699**
1/2-HP

1725-rpm Capacitor-start for bench saws, pumps, compressors, etc.

1 Mount in any position. Reversible. 56-frame. 1-phase 60-c. AC. Mounting 3x4 3/4 in. 4-ft., 3-wire cord, adapter (except 9 KT 1227C).

1/2-HP. *Sleeve bearings.* Overload protector. Single-end shaft (1/2-in. diam., 3/8-inch deep flat with 3/16-in. adapter sleeve). Resilient base.

9 KT 1970C—(110-120 or 230-volt.) Shipping weight 19 pounds. \$39.99

1/2-HP. *Sleeve bearings.* Double-end shaft 1/2-in. 3/8-in. deep flattened shaft (with 3/8-inch adapter) and 3/8 with 3/16-inch square keyway. Resilient base.

9 KT 1214C—(110-120-volt.) Shipping weight 21 pounds. \$44.99

1/2-HP. *Ball bearings.* For pumps, compressors, etc. Overload protector. Double-end shaft (1/2-inch, 3/8-inch adapter sleeve, 3/8-inch diameter). Rigid base.

9 KT 1213C—(110-120 or 230-volt.) Shipping weight 22 pounds. \$54.99

3/4-HP (not shown). *Sleeve bearings.* For CRAFTSMAN metal-turning lathes. Single-end shaft (3/8-in. diameter with 3/16-in. keyway). Resilient base. No cord.

9 KT 1227C—(110-120 or 230-volt.) Shipping weight 25 pounds. \$57.99

1-HP. *Ball bearings.* For pumps, compressors, etc. Overload protector. Single-end shaft (3/8-in. diameter with 3/16-in. keyway). Rigid base.

9 KT 1215C—(110-120 or 230-volt.) Shipping weight 32 pounds. \$74.99

Split-phase for loads that start easily . . . small drill presses, lathes, jig saws

2 Also for small band saws, grinders, belt sanders, etc. Bolts are extended through for end-bell mounting. Reversible rotation. 110-120-v., 60-c. single phase AC. 1725 rpm. Sleeve bearings. 3x4 3/4-in. resilient base mounting. Mounts in any position. Mylar polyester insulated. 4-ft., 3-wire cord, plug and adapter. Overload protector not incl. Order on-off switch below.

Catalog No.	HP	Shaft-end diameter	Shpg. wt.	Each
9 KT 1210C	1/2	Single 1/2 in.*	16 lbs.	\$26.99
9 KT 1211C	3/4	Single 1/2 in.*	18 lbs.	29.99
9 KT 1212C	1	Double 3/8*-5/8 in.**	19 lbs.	33.99

*With 3/8-inch adapter sleeve and 3/16-inch flat on sleeve
**With 3/16-inch square keyway †Registered DuPont trademark

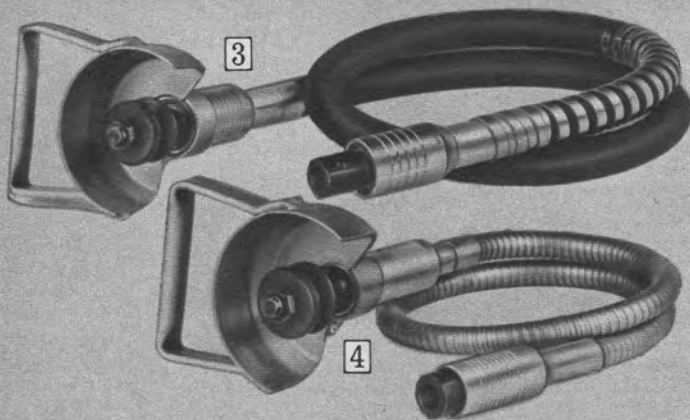

Flexible Shafts with Wheel Guards

3 CRAFTSMAN 72-inch heavy-duty Shaft. Extra long. 1/2-inch wire core. Spiral-steel liner has oil-resistant fabric jacket; reinforced synthetic rubber cover for longer life and maximum durability. Chrome-plated steel motor couplings with handy knurled hand piece. Extra-large ball bearings. 1/2-inch x 20-thread spindle. Fits any 1/2 or 3/8-inch motor shaft up to 1-HP capacity. Operates at 1725 or 3450 rpm. Includes wheel guard (for 4-inch wheels) with convenient hand grip.

Shipping weight 15 pounds.
9 KT 26558C2. \$59.50

4 50-inch Shaft. For farm or home workshop uses. 3/8-inch core. Aluminum-alloy handpiece and coupling with long wearing ball bearings. Steel end fittings. 1/2-inch x 20-thread spindle. Fits any 1/2 or 3/8-inch motor shaft with 1/2-HP capacity. Operates at 1725 or 3450 rpm. Includes wheel guard (for 4-inch wheels) with convenient hand grip.

Shipping weight 7 lbs. 8 oz.
9 KT 26337. \$34.50

38-inch Extension. Use with (4) above. Wt. 3 lbs. 2 oz.
9 KT 2634. \$9.99



Low as **\$3799**

Blower and Fan Motors

Replace 1/2, 1/2, 1/2, 1/2-HP furnace, attic, window-blower motors. 1/2-HP split-phase, 110-120-v., 60-c. AC. Reversible. Mount in any position. Automatic reset overload protector. Single-end 1/2-in. shaft with 3/8-in. flat, 3/8-in. adapter. Sleeve bearings. Through-bolts for direct drive fans. Flexible NEMA mounting—2 7/16x4 1/2 in. (48 frame); 3x4 3/4 in. (56 frame).

Single-speed. 1725 rpm. 2 7/16x4 1/2-in. mounting.

9 KT 19835C—Shipping weight 18 lbs. \$37.99

Single-speed. 1725 rpm. 3x4 3/4-in. mounting.

9 KT 1983C—Shipping weight 20 lbs. 37.99

2-speed. 1140 or 1725 rpm. 3x4 3/4-in. mounting.

9 KT 1971C—Shipping weight 22 lbs. \$42.99

Motor Accessories for bench power tools



5 Floating Motor Rails. For motors 1 HP and less moved from one power tool to another. 2 3/8 to 5 inches between centers. Fasteners included.

9 KT 2265—Set of 1 rail, 2 clips. Wt. 15 oz. \$2.19
9 KT 2268—Pkg. of 2 clips only. Wt. 6 oz. 79c

6 On-off Rocker Switch. For bench power tools; can be mounted. For motors up to 1 HP (universal motors to 1 1/2 HP). 8-ft., 3-wire cord. 110-120-v. AC, 15 amps. Two 3-prong receptacles—one controlled by switch; one always "on" for lamps, etc.

9 KT 12085—Shipping weight 1 lb. 8 oz. \$7.99

standard mounts..will replace any make motor

Extra-torque 1/3 to 7 1/2-HP Motors..for compressors, pumps, sprayers, machine tools

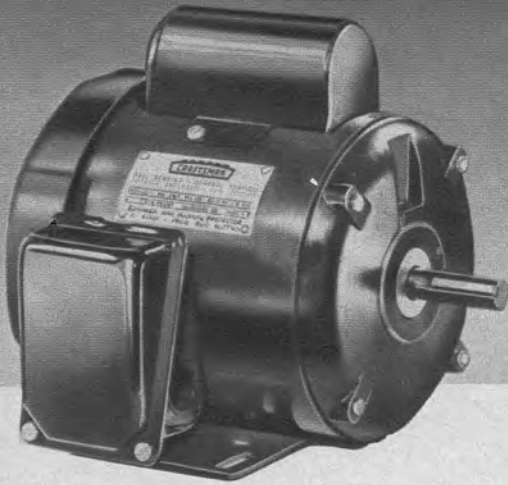

CRAFTSMAN® general-purpose, capacitor-start Motor

1/2-HP \$49.95

1725 rpm. Induction-run, extra-torque. For tough-starting loads on the farm such as grain-handling augers . . many other jobs in the workshop, etc. Rigid base mount—measures 3x4 3/4 inches 56-frame. Totally enclosed and fan-cooled. 5/8-inch keyed single end shaft.

Permanently sealed ball bearings—need no lubrication . . run quietly and longer. Manual reset overload protector. Electrically reversible. Mount in any position. No oil cups or drainage. 110-120 or 230-volt, 60-cycle, single phase AC. No switch or cord.

Catalog Number	HP	Shipping weight	Price
9 KT 1222C	1/8	.22 pounds	\$49.95
9 KT 1223C	1/4	.26 pounds	54.50
9 KT 1224C	3/8	.35 pounds	64.99
9 KT 1225C	1	.40 pounds	76.99

MOTOR BOOK

This book included with each Sears motor. Gives valuable information on motor installation, applications and maintenance.



MOTOR GUARANTEE

We will repair at no charge, any Sears Electric Motor proving defective in materials or workmanship, if returned within one year from date of purchase.

SHIPPING NOTE: "N" items (as 9 KT 12816N) shipped by motor carrier or express.

Sears Has a Credit Plan to Suit Your Needs

See Big Book or ask for details

CRAFTSMAN® Heavy-duty Motors . . be sure they'll fit

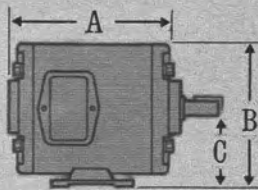

LEGEND FOR DIAGRAM AND TABLE BELOW: "A"—length of motor housing (excluding motor shaft). "B"—distance from bottom of base plate to top of motor housing. "C"—distance from bottom of base plate to center of motor shaft. "D"—max. width of motor housing.

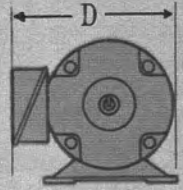

NOTE: DIMENSIONS IN THE TABLE BELOW GIVEN IN INCHES

Catalog Number	A	B	C	D	Catalog Number	A	B	C	D
9 KT 12806L	12 1/4	8 1/4	4 1/2	11 1/4	9 KT 12706L	11 5/8	8 1/4	4 1/2	11 1/4
9 KT 12816N	13 5/8	8 3/4	4 1/2	11 1/4	9 KT 12716N	12 1/8	8 3/4	4 1/2	11 1/4
9 KT 12826N	13 3/8	10	5 1/4	12 1/4	9 KT 12726N	12 1/2	9 3/4	5 1/4	12 3/8
9 KT 12836N	14 5/8	8 3/4	4 1/2	11 1/4	9 KT 12736N	12 5/8	8 3/4	4 1/2	11 1/4
9 KT 12847N	15 3/8	10	5 1/4	12 1/4	9 KT 12747N	13 1/2	9 3/4	5 1/4	12 5/8
9 KT 12856N	15 3/8	10 3/4	5 1/4	14	9 KT 12756N	14	10 1/4	5 1/4	15
9 KT 12866N	16 3/8	10 3/4	5 1/4	14	9 KT 12766N	15	10 1/4	5 1/4	15

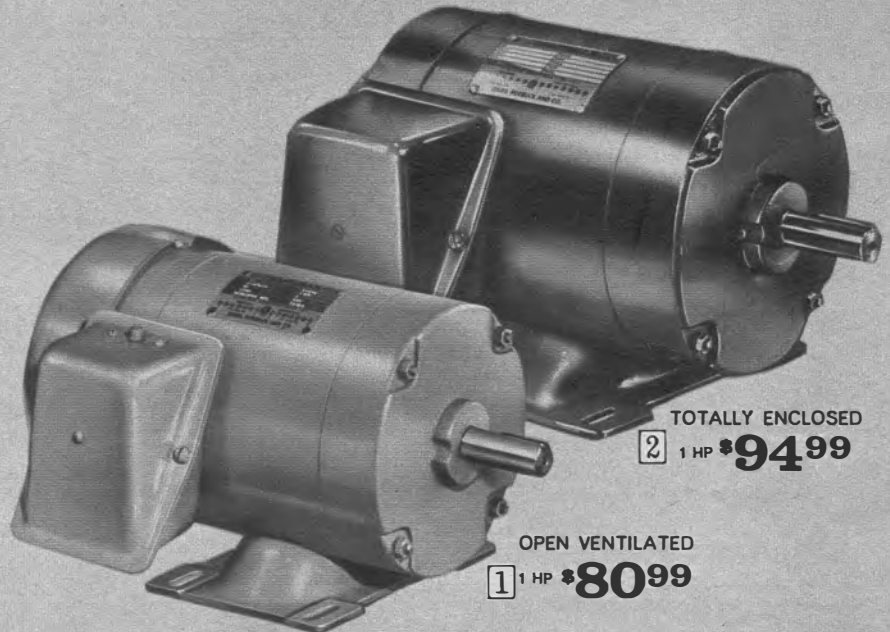

TOTALLY ENCLOSED

2 1 HP \$94.99

OPEN VENTILATED

1 1 HP \$80.99

CRAFTSMAN® open-ventilated Motors

1 **Big overload capacity, capacitor-start, induction-run.** For equipment with high-starting torque—pumps, crop driers, ventilating fans, blowers, deep freezers, air compressors. Permanently lubricated, grease-sealed ball bearings for extra thrust loads. Manual reset overload protector prevents burn-outs. Electrically reversible. *Open frame.* Mount in any position.

No oil cups, drainage. Single end shaft. No switch or cord. 60-cycle single phase 110-120 or 230-volt, AC (3, 5 and 7 1/2-HP motors, 230-volt only). Guaranteed 1 year (see Guarantee, left).

Catalog Number	HP	RPM	Frame size	Shaft diameter	Key width	Base mount inches	Shipping weight	Price
9 KT 12706L	.1	1725	.182	7/8 inch	3/16 inch	4 1/2 x 7 1/2	63 pounds	\$80.99
9 KT 12716N	.1 1/2	1725	.184	7/8 inch	3/16 inch	5 1/2 x 7 1/2	74 pounds	92.99
9 KT 12726N	.2	1725	.213	1 1/8 inch	1/4 inch	5 1/2 x 8 1/2	92 pounds	109.95
9 KT 12736N	.2	3450	.184	7/8 inch	3/16 inch	5 1/2 x 7 1/2	74 pounds	114.95
9 KT 12747N	.3	1725	.215	1 1/8 inch	1/4 inch	7 x 8 1/2	113 pounds	159.95
9 KT 12756N	.5	1725	.215	1 1/8 inch	1/4 inch	7 x 8 1/2	122 pounds	184.95
9 KT 12766N	.7 1/2	1725	.215	1 1/8 inch	1/4 inch	7 x 8 1/2	176 pounds	274.95

CRAFTSMAN® totally enclosed Motors

2 **Fan-cooled, capacitor-start, induction run.** For outside installations; also for use where dust or dirt is a problem such as with grain conveyors, barn cleaners, silo unloaders, hay elevators and the like. Drain holes allow installation outside or in unprotected locations. Permanently lubricated grease-sealed ball bearings for long-wearing performance.

Manual reset overload protector prevents burn-outs. Electrically reversible. Mount in any position. Single-end shaft. No switch or cord. 60-cycle single phase 110-120 or 230-volt AC (3, 5, 7 1/2-HP motors for 230-volt only). Guaranteed one year—see details at left.

Catalog Number	HP	RPM	Frame Size	Shaft diameter	Key width	Base mount inches	Shipping weight	Price
9 KT 12806L	.1	1725	.182	7/8 in.	3/16 inch	4 1/2 x 7 1/2	63 pounds	\$94.99
9 KT 12816N	1 1/2	1725	.184	7/8 in.	3/16 inch	5 1/2 x 7 1/2	65 pounds	107.95
9 KT 12826N	.2	1725	.213	1 1/8 in.	1/4 inch	5 1/2 x 8 1/2	90 pounds	129.95
9 KT 12836N	.2	3450	.184	7/8 in.	3/16 inch	5 1/2 x 7 1/2	75 pounds	132.95
9 KT 12847N	.3	1725	.215	1 1/8 in.	1/4 inch	7 x 8 1/2	93 pounds	189.95
9 KT 12856N	.5	1725	.215	1 1/8 in.	1/4 inch	7 x 8 1/2	104 pounds	244.95
9 KT 12866N	.7 1/2	1725	.215	1 1/8 in.	1/4 inch	7 x 8 1/2	196 pounds	344.95

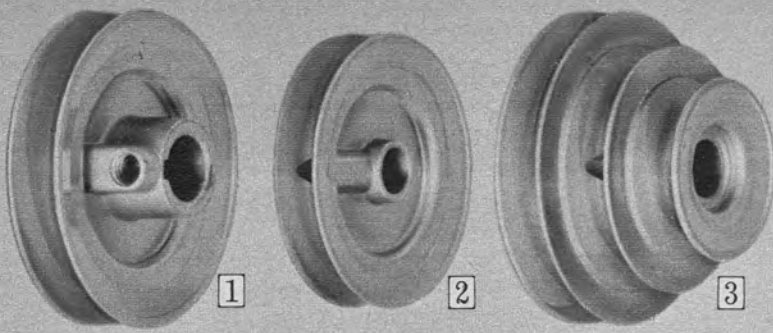

CRAFTSMAN® precision-machined V-pulleys

(1 thru 3) Scientifically designed to give you top working performance. Grooves machined to maximum accuracy . . . helps eliminate belt slipping, power loss. All bores reamed to exact size.

To determine motor pulley diameter—multiply the diameter of the machine pulley by the machine rpm wanted. Divide this figure by the motor rpm for the motor pulley diameter needed.

To determine machine pulley diameter—multiply the motor pulley diameter by the motor rpm. Divide this figure by the machine rpm you want.

NOTE: All the diameters given in tables are for outer edge of pulleys only.

1 Die-cast Single-groove V-pulleys. Made of zinc alloy with an aluminum finish. Socket-head set-screw. Fit $\frac{3}{8}$ (3L) or $\frac{1}{2}$ -in. (4L) V-belts, except 9 KT 2800 which is for $\frac{3}{8}$ -inch (3L) belt only. Both $\frac{3}{8}$ and $\frac{1}{2}$ -inch bores have standard keyway.

Catalog Number	Outside diam., in.	Bore size inches	Shpg. wt.		Each
			lbs.	oz.	
9 KT 2800	1 1/2	1/2	4		69c
9 KT 28011	2	3/4	5		79c
9 KT 28012	2	3/4	5		79c
9 KT 28021	2 1/2	3/4	7		89c
9 KT 28022	2 1/2	3/4	7		89c
9 KT 28023	2 1/2	3/4	7		89c
9 KT 28031	3	3/4	7		99c
9 KT 28032	3	3/4	8		99c
9 KT 28033	3	3/4	8		99c
9 KT 28041	4	3/4	10		\$1.19
9 KT 28042	4	3/4	10		1.19
9 KT 28043	4	3/4	10		1.19
9 KT 28051	5	3/4	12		1.39
9 KT 28052	5	3/4	12		1.39
9 KT 28053	5	3/4	12		1.39
9 KT 28061	6	3/4	15		1.59
9 KT 28062	6	3/4	1		1.59
9 KT 28063	6	3/4	1		1.59

*These pulleys are spoke type.

2 Hubless Single-groove V-pulleys. Zinc alloy, aluminum finish. Use side by side for multiple drives. Socket-head setscrew. Fit $\frac{3}{8}$ -in. (3L) or $\frac{1}{2}$ -in. (4L) V-belts. 2 1/2, 3-in. diam. pulleys in $\frac{3}{8}$, $\frac{1}{2}$ -in. bores have std. keyways.

Catalog Number	Outside diameter	Bore size	Shipping weight	Each
9 KT 29011	2 in.	3/8 in.	5 oz.	79c
9 KT 29012	2 in.	3/8 in.	5 oz.	79c
9 KT 29021	2 1/2 in.	3/8 in.	6 oz.	89c
9 KT 29022	2 1/2 in.	3/8 in.	6 oz.	89c
9 KT 29023	2 1/2 in.	3/8 in.	7 oz.	89c
9 KT 29031	3 in.	3/8 in.	7 oz.	99c
9 KT 29032	3 in.	3/8 in.	8 oz.	99c
9 KT 29033	3 in.	3/8 in.	8 oz.	99c

3 Die-cast Cone V-pulleys. Made of zinc alloy with aluminum finish. 3 or 4-step. Socket-head setscrew. Fit $\frac{3}{8}$, $\frac{1}{2}$ -in. V-belts. $\frac{3}{8}$, $\frac{1}{2}$ -inch bores have standard keyway.

Catalog Number	Bore size, inches	Step diameter, inches	Shpg. wt. lbs. oz.	Each
9 KT 27881	3/8	3/8, 2/8, 2	1	\$1.69
9 KT 27882	3/8	3/8, 2/8, 2	1	1.69
9 KT 27883	3/8	3/8, 2/8, 2	1	1.69
9 KT 27921	3/4	4.3, 3/8, 2/8, 2	1 6	1.99
9 KT 27922	3/4	4.3, 3/8, 2/8, 2	1 7	1.99
9 KT 27923	3/4	4.3, 3/8, 2/8, 2	1 6	1.99
9 KT 27931	3/4	5.4, 3.2	1 9	2.49
9 KT 27932	3/4	5.4, 3.2	1 10	2.49
9 KT 27933	3/4	5.4, 3.2	1 10	2.49



CRAFTSMAN® V-Belts

Low as **\$1.19**

Length-coding assures you of perfect matching for multiple drives. Every belt balanced to run true. Tough, yet elastic enough to handle heavy shock loads. High twist cover fabric, neoprene impregnated. Resists oils, heat, etc.



HOW TO MEASURE BELTS

Measuring width: Measure across broader (outside) surface of belt being replaced (see sketch "A" above).

Measuring length: Measure around outside edge of both pulleys, not in groove (see sketch "B" above). Use steel tape. Check manufacturer's number on your old belt.

Catalog No.	Length	Mfr's. No.	Shpg. wt.	Each
3/8-inch (For CRAFTSMAN Drill Presses only.)				
9 KT 1745	45 in.	3L370	3 oz.	\$3.99
1/2-inch				
3L-Section				
9 KT 1529	29 in.	3L290	4 oz.	\$1.19
9 KT 1537	37 in.	3L370	4 oz.	1.19
4L-Section				
9 KT 1617	17 in.	4L170	4 oz.	\$1.19
9 KT 1618	18 in.	4L180	4 oz.	1.19
9 KT 1619	19 in.	4L190	4 oz.	1.19
9 KT 1620	20 in.	4L200	4 oz.	1.19
9 KT 1621	21 in.	4L210	4 oz.	1.19
9 KT 1622	22 in.	4L220	4 oz.	1.19
9 KT 1623	23 in.	4L230	4 oz.	1.19
9 KT 1624	24 in.	4L240	4 oz.	1.19
9 KT 1625	25 in.	4L250	4 oz.	1.19
9 KT 1626	26 in.	4L260	5 oz.	1.19
9 KT 1627	27 in.	4L270	5 oz.	1.19
9 KT 1628	28 in.	4L280	5 oz.	1.19
9 KT 1629	29 in.	4L290	5 oz.	1.19
9 KT 1630	30 in.	4L300	5 oz.	1.19
9 KT 1631	31 in.	4L310	5 oz.	1.29
9 KT 1632	32 in.	4L320	5 oz.	1.29
9 KT 1633	33 in.	4L330	5 oz.	1.29
9 KT 1634	34 in.	4L340	5 oz.	1.29
9 KT 1635	35 in.	4L350	5 oz.	1.29
9 KT 1636	36 in.	4L360	5 oz.	1.29
9 KT 1637	37 in.	4L370	5 oz.	1.29
9 KT 1638	38 in.	4L380	6 oz.	1.29
9 KT 1639	39 in.	4L390	6 oz.	1.29
9 KT 1640	40 in.	4L400	6 oz.	1.29
9 KT 1641	41 in.	4L410	6 oz.	1.39
9 KT 1642	42 in.	4L420	6 oz.	1.39
9 KT 1643	43 in.	4L430	6 oz.	1.39
9 KT 1644	44 in.	4L440	6 oz.	1.39
9 KT 1645	45 in.	4L450	6 oz.	1.39
9 KT 1646	46 in.	4L460	7 oz.	1.39
9 KT 1647	47 in.	4L470	7 oz.	1.39
9 KT 1648	48 in.	4L480	7 oz.	1.39
9 KT 1649	49 in.	4L490	7 oz.	1.39
9 KT 1650	50 in.	4L500	7 oz.	1.39
9 KT 1652	52 in.	4L520	7 oz.	1.59
9 KT 1654	54 in.	4L540	7 oz.	1.59
9 KT 1656	56 in.	4L560	7 oz.	1.69
9 KT 1658	58 in.	4L580	7 oz.	1.69
9 KT 1660	60 in.	4L600	8 oz.	1.69
9 KT 1662	62 in.	4L620	8 oz.	1.69
9 KT 1664	64 in.	4L640	8 oz.	1.69
9 KT 1666	66 in.	4L660	8 oz.	1.69
9 KT 1668	68 in.	4L680	8 oz.	1.69
9 KT 1670	70 in.	4L700	8 oz.	1.79
9 KT 1672	72 in.	4L720	9 oz.	1.79

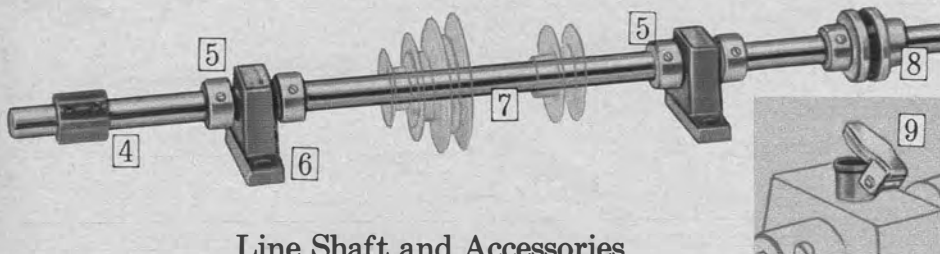

Line Shaft and Accessories

Mount line shaft, couplings and collar on bench or as overhead drive. Use $\frac{1}{2}$ -HP motor or larger.

Steel Line Shaft—use $\frac{1}{2}$ -inch for light tools; use $\frac{3}{8}$ or $\frac{1}{2}$ -inch for heavier machines, larger motors.

Rigid Coupling—use to connect sections.

Flexible Coupling—use to connect motor to shaft.

Line Shaft Collar—helps prevent endwise drift.

NOTE

Line shaft collar (listed in table at right) has $\frac{3}{8}$ -inch bore with bushings for $\frac{1}{2}$ and $\frac{3}{8}$ -inch shafts.

Catalog No.	Size	Accessory	Shpg. wt.	Each
4 9 KT 28393	3/4-inch	Rigid Coupling	11 oz.	\$1.99
9 KT 28394	1/2, 3/8-inch	Rigid Coupling	8 oz.	1.99
5 9 KT 28255	1/2, 3/8, 3/4-in.	Line Shaft Collar	6 oz.	99c
6 9 KT 27501	1/2-inch	Pillow Block	14 oz.	2.49
9 KT 27502	3/4-inch	Pillow Block	14 oz.	2.49
9 KT 27503	3/4-inch	Pillow Block	1 lb.	2.49
7 9 KT 2833	1/2x24-inch	Steel Line Shaft	1 lb. 15 oz.	1.49
9 KT 2834C	1/2x48-inch	Steel Line Shaft	3 lbs.	2.49
9 KT 2830C	3/4x48-inch	Steel Line Shaft	5 lbs.	3.49
9 KT 2835C	3/4x48-inch	Steel Line Shaft	7 lbs.	4.49
8 9 KT 28403	3/4-inch	Flexible Coupling	13 oz.	2.29
9 KT 28404	1/2, 3/8-inch	Flexible Coupling	13 oz.	2.29
9 9 KT 2820	1/4-inch	Cup Oiler	2 oz.	39c

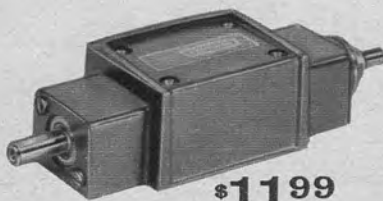

\$11.99

CRAFTSMAN® Single-end Mandrel

Excellent for polishing and buffing metals and plastic; ideal for removing paint and rust. Sturdy aluminum alloy construction with permanently lubricated ball bearings for long life. Two removable machine flanges with $\frac{1}{4}$ -in. diameters included. $\frac{5}{8}$ x12 $\frac{1}{2}$ -in. shaft with $\frac{1}{2}$ -in. x20 right-hand thread on one end; other end flattened with $\frac{3}{8}$ -in. diameter for pulley and setscrew. Machine pulley not included . . . see listings above. Speed should not exceed 3450 rpm. Shipping weight 3 pounds 1 ounce. 9 KT 4955 . . . \$11.99



Sanding Drum

10 With 3-inch face. Diameter measures 2 1/4-inches. Screws on 1/2-inch x 20-thread shaft. Comes with medium grit sanding sleeve over expanding rubber drum. 9 KT 25246—Wt. 1 lb. 3 oz. . . \$3.49

11 Extra Sanding Sleeves for above.

Catalog No.	Grit	Shpg. wt.	Each
9 KT 25221	Fine	3 oz.	39c
9 KT 25222	Medium	3 oz.	39c
9 KT 25223	Coarse	3 oz.	39c

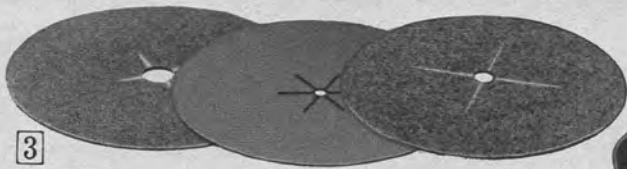
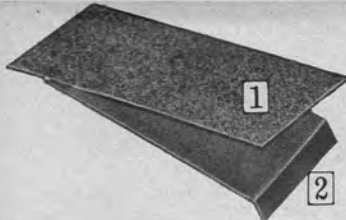

ABRASIVES

Smooth, fast cutting Sanding Sheets

1 Aluminum Oxide Sanding Sheets. Cost less per job; grits outlast most other types. Paper-backed for hand or machine work on hard woods.

3x7 3/4-inch Sheets. Package of 18... Pkg. 69c

Catalog Number	Grit	Wt. oz.
9 KT 27461	Fine... 3	...
9 KT 27462	Medium... 4	...
9 KT 27463	Coarse... 5	...

3 3/8x9-inch Sheets. Package of 12... Pkg. 79c

Catalog Number	Grit	Wt. oz.
9 KT 25131	Fine... 3	...
9 KT 25132	Medium... 4	...
9 KT 25133	Coarse... 5	...
9 KT 25134	X-coarse... 7	...

4 1/2x11-inch Sheets. Package of 12... Pkg. 79c

Catalog Number	Grit	Wt. oz.
9 KT 27401	Fine... 4	...
9 KT 27402	Medium... 4	...
9 KT 27403	Coarse... 6	...
9 KT 27404	X-coarse... 10	...

Non-clog Sanding Sheets. Rubber-treated paper back. Ideal for orbital, reciprocating power sanders. *Fine grits are silicon carbide. Medium and coarse are aluminum oxide.*

3x7 3/4-inch Sheets. Package of 12... Pkg. 69c

Catalog Number	Grit	Wt. oz.
9 KT 67621	Fine... 5	...
9 KT 67622	Medium... 6	...
9 KT 67623	Coarse... 7	...

3 3/8x9-inch Sheets. Package of 12... Pkg. 79c

Catalog Number	Grit	Wt. oz.
9 KT 67645	Fine... 5	...
9 KT 67646	Medium... 6	...
9 KT 67647	Coarse... 8	...

4 1/2x11-inch Sheets. Package of 12... Pkg. 89c

Catalog Number	Grit	Wt. oz.
9 KT 67635	Fine... 6	...
9 KT 67636	Medium... 8	...
9 KT 67637	Coarse... 10	...

For 9x11-in. sanding sheets, see at far right below.

Tungsten Carbide Karbo-Grits

2 Neoprene-backed Sheets. Outlast ordinary sandpaper 40 to 1. Grits permanently brazed to steel wheels, discs, sheets. If clogged, shake out and wirebrush... use gum, pitch remover. For platen-sanders, orbital and dual-action electric sanders.

3 3/8x9 1/8-inch Sheets.

9 KT 30281	Fine	...
9 KT 30282	Medium	...
9 KT 30283	Coarse	...

Wt. ea. 5 oz. ... Ea. \$1.49

4 1/2x11 1/8-inch Sheets.

9 KT 30291	Fine	...
9 KT 30292	Medium	...
9 KT 30293	Coarse	...

Wt. ea. 7 oz. ... Ea. \$1.99



4 Abrasive Wheel. For bench, radial-arm saws. For plywood, veneers. Coarse grit, one side, edge; medium grit, other side. Each has knockout-bushed round hole. Outlasts ordinary sandpaper 40 to 1.

8-in. diameter. 5/8 to 1/2-in. hole.
9 KT 30001—Wt. 2 lbs. 10 oz. ... \$4.99

10-in. diameter. 3/4 to 5/8-in. hole.
9 KT 30003—Wt. 4 lbs. 2 oz. ... \$6.99

5 CRAFTSMAN Steel Wool. Pkg. of 16 pads, Wt. 1 lb. 3 oz.

Catalog No.	Texture	Pkg.
9 KT 67919	Very Fine #0000...	\$1.39
9 KT 67911	Extra-Fine #000...	1.19
9 KT 67912	Fine #0...	79c
9 KT 67913	Medium #1...	79c
9 KT 67914	Med. Coarse #2...	79c
9 KT 67915	Coarse #3...	79c

3 Discs for portable, bench-type sanders.

Diam.	Hole	Grit	Pkg.	Catalog Number	Wt. lbs.	Price Pkg.
Aluminum Oxide, paper-backed						
4-in.	1/4-in.	Asstd.*	6	9 KT 2544	...	59c
5-in.	None	X-Fine	6	9 KT 26051	...	59c
		Fine	6	9 KT 26052	...	59c
		M-Fine	6	9 KT 26053	...	59c
5-in.	1/4-in.	Coarse	3	9 KT 2542	...	59c
		Asstd.†	6	9 KT 2543	...	59c
		Fine	6	9 KT 25321	...	79c
6-in.	1/4-in.	Med.	6	9 KT 25322	...	79c
		Coarse	4	9 KT 25323	...	79c
		Asstd.*	6	9 KT 25325	...	79c
7-in.	1/4-in.	Asstd.*	6	9 KT 2531	...	99c
		Fine	6	9 KT 25251	...	\$1.19
		Med.	6	9 KT 25252	...	1.19
8-in.	None	Coarse	5	9 KT 25253	...	1.19
		Asstd.*	6	9 KT 22732	...	1.19
		Fine	6	9 KT 25261	...	1.29
9-in.	3/8-in.	Med.	6	9 KT 25262	...	1.29
		Coarse	5	9 KT 25263	...	1.29
		Asstd.*	6	9 KT 22731	...	1.69
10-in.	3-in.	Asstd.*	6	9 KT 22731	...	1.69
Aluminum Oxide, fiber-backed						
6-in.	3/8-in.	Med.	10	9 KT 25297	...	\$3.99
		Fine	10	9 KT 25299	...	3.79
		Med.	10	9 KT 25291	...	3.99
7-in.	3/8-in.	Coarse	10	9 KT 25292	...	4.19
		Med.	10	9 KT 25297	...	3.99
		Fine	10	9 KT 25299	...	3.79
No-load (F. silicon carbide, M., C., alum. oxide)						
5-in.	1/4-in.	Fine	6	9 KT 67615	...	69c
		Med.	6	9 KT 67616	...	69c
		Coarse	6	9 KT 67617	...	69c
Silicon Carbide, open coat						
6-in.	1/4-in.	Coarse	3	9 KT 25324	...	79c

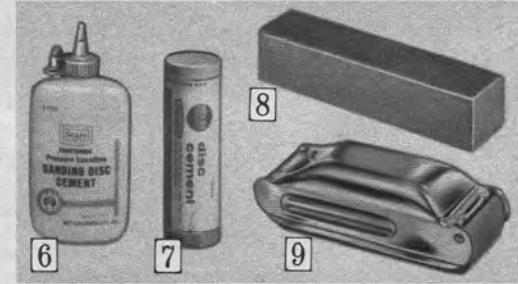

Cement Supplies

6 CRAFTSMAN Pressure-sensitive Cement. Stays tacky. Comes in 8-ounce plastic bottle. Wt. 14 oz.
9 KT 2220... Ea. 89c

7 Stick Dry Cement. A non-drying cement. The disc peels off after use. Made of a mixture of rosin, animal, vegetable and mineral greases and waxes. Comes in a convenient 4 1/2-oz. tube. Shpg. wt. 6 oz.
9 KT 2219... Ea. 59c

Sanding Blocks and Refills

8 Sanding Block... for fast stock removal. Wears to shape of irregular surfaces. Manufactured from silicates. 9x2x2 inches.
9 KT 6439—Shpg. wt. 6 oz. ... 39c

9 COMPANION Sanding Block. Not CRAFTSMAN. Opens to replace sand paper. 30x1 1/2-in. roll. 6-in. steel frame. Felt cushion.
9 KT 3681—Shpg. wt. 12 oz. ... \$1.49

Garnet Refills for (9) above. Long rolls measure 30x1 1/2 inches.

9 KT 36881	Fine	...
9 KT 36882	Medium	...
9 KT 36883	Coarse	...

Shpg. wt. roll 3 oz. ... Each 25c

Sanding Sheets

Quality-made abrasives bonded to strong backings

No-load Paper. 9x11-in. Pkg. of 6.

9 KT 67624	Med. Fine	Wt. 5 oz. ... Pkg. 79c
9 KT 67625	Fine	Shpg. wt. 6 oz. ... Pkg. 79c
9 KT 67626	Medium	Wt. 8 oz. ... Pkg. 79c
9 KT 67627	Coarse	Wt. 10 oz. ... Pkg. 79c

Aluminum Oxide, paper-backed. For hardwood. 9x11-in. sheets. Pkg. of 6.

9 KT 27411	X-Fine	Shpg. wt. 6 oz. ... Pkg. 79c
9 KT 27412	Fine	Wt. 8 oz. ... Pkg. 79c
9 KT 27413	Medium	Wt. 11 oz. ... Pkg. 79c
9 KT 27414	Coarse	Wt. 15 oz. ... Pkg. 79c

Aluminum Oxide, cloth-backed. For metal. 9x11-in. sheets. Package of 3.

9 KT 67891	Fine	Shpg. wt. 6 oz. ... Pkg. 99c
9 KT 67892	Medium	Wt. 7 oz. ... Pkg. 99c
9 KT 67893	Coarse	Wt. 9 oz. ... Pkg. 99c

Garnet Paper. 9x11-in. Pkg. of 6.

9 KT 67956	X-Fine	Wt. 6 oz. ... Pkg. 79c
9 KT 67957	Fine	Shpg. wt. 8 oz. ... Pkg. 79c
9 KT 67958	Medium	Wt. 11 oz. ... Pkg. 79c
9 KT 67959	Coarse	Wt. 1 lb. ... Pkg. 79c

Emery Cloth. 9x11-in. Pkg. of 3.

9 KT 67981	Fine	Shpg. wt. 6 oz. ... Pkg. 59c
9 KT 67982	Medium	Wt. 6 oz. ... Pkg. 59c
9 KT 67983	Coarse	Wt. 7 oz. ... Pkg. 59c

Flint Sandpaper. For soft woods only. 9x10-inch sheets. Package of 12.

9 KT 67931	X-Fine	Shpg. wt. 8 oz. ... Pkg. 59c
9 KT 67932	Fine	Wt. 10 oz. ... Pkg. 59c
9 KT 67933	Medium	Wt. 12 oz. ... Pkg. 59c
9 KT 67934	Coarse	Wt. 1 lb. 2 oz. ... Pkg. 59c

Silicon Carbide Watersand Finishing-paper. 9x11-in. sheets. Package of 6.

9 KT 30111	Super Fine	Wt. 5 oz. ... Pkg. 79c
9 KT 30112	X-Fine	Wt. 6 oz. ... Pkg. 79c
9 KT 30113	Med. Fine	Wt. 6 oz. ... Pkg. 79c

CRAFTSMAN® Grinding Wheels

Low as **89c** medium fine or fine grit, 3x 1/2 inch

Made of aluminum-oxide abrasive grains, first quality and uniform size. Perfectly balanced. Both sides and face precision ground... fully vitrified (crystallized) in an electrically controlled kiln. Meet the highest industrial standards, including safety standards of American Standards Association. 3/4-in. center hole. Bushings for 3/8, 1/2 and 5/8 in. included with 3 and 4-in. wheels. Bushings for 3/4 and 5/8 in. included with 5, 6, 7 and 8-in. wheels. Made in the U.S.A.

IMPORTANT SAFETY RULES: (1) Do not grind on side of wheels. (2) Grinding wheels should be used only with concave flanges as large as, or larger than, shown in table below. (3) Use guard and shatterproof glass shield covering 3/4 of wheel. (4) For all wheels, never exceed rpm shown. (5) Wear safety goggles. (6) Stand aside one minute after starting wheel. (7) Follow safety instructions shown on grinding wheels and cutoff wheels. Do not use on wood.

Wheel diameter, inches.	3	4	5	6	7	8
Flange diameter, inches.	1 3/4	1 3/4	1 3/4	2	2 1/2	3
RPM.	8276	6207	4966	4138	3600	3600

Fine... for knives, keen-edged tools, finish grinding and polishing.
Medium Fine... for axes, woodcutting tools, preparation for finish.
Medium Coarse... for machine shop use, or fast removal of stock.

Diameter and thickness	Min. size	Shpg. wt.	Fine 100 grit		Medium Fine 60 grit		Medium Coarse 36 grit	
			Cat. No.	Each	Cat. No.	Each	Cat. No.	Each
3x 1/2 in.	3/8-in.	1.1	9 KT 64311	89c	9 KT 64201	89c
3x 3/4 in.	3/8-in.	1.1	9 KT 64312	99c	9 KT 64202	99c
4x 1/2 in.	3/8-in.	1.1	9 KT 64313	\$1.29	9 KT 64203	\$1.29
4x 3/4 in.	3/8-in.	1.2	9 KT 64314	1.49	9 KT 64204	1.49
4x 1 in.	3/8-in.	1.2	9 KT 64205	1.69
5x 1/2 in.	1/2-in.	1.2	9 KT 64206	1.79	9 KT 64239	\$1.79
5x 3/4 in.	1/2-in.	1.3	9 KT 64317	2.19	9 KT 64207	1.99
5x 1 in.	1/2-in.	1.3	9 KT 64318	2.29	9 KT 64208	2.29
6x 1/2 in.	1/2-in.	1.3	9 KT 64319	2.19	9 KT 64209	1.99
6x 3/4 in.	1/2-in.	1.3	9 KT 64321	2.39	9 KT 64211	2.29	9 KT 64232	2.39
6x 1 in.	1/2-in.	1.4	9 KT 64322	2.69	9 KT 64212	2.69	9 KT 64233	2.69
7x 3/4 in.	1/2-in.	1.4	9 KT 64213	2.79
7x 1 in.	1/2-in.	1.5	9 KT 64214	3.19	9 KT 64235	3.19
8x 1 in.	3/4-in.	1.6	3.89	9 KT 64236	3.89

Grinding Wheel for carbide-tip tools. Fine grit. 6x 1/2-in. thick.
9 KT 64242—Shipping weight 3 pounds... \$2.69



CRAFTSMAN® Electric Grinders

Fully enclosed to seal out grinding dust, dirt. Permanently lubricated ball bearings for smooth running. Guaranteed 1 full year

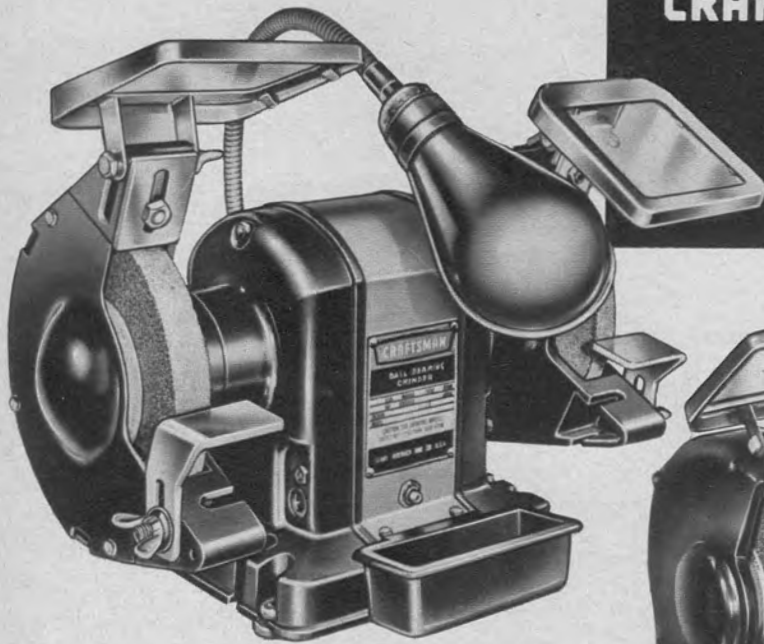

CRAFTSMAN® with 1/2-HP motor and two 6x3/4-inch wheels

***\$6999**

Split-phase 3450-rpm motor. Super-hard aluminum oxide grinding wheels . . . one 36 grit (med. coarse), one 60 grit (med. fine). Flat-faced cast aluminum housing for maximum work area; rubber mounted. Adjustable tool rests and safety-glass eye shields. Spark arrestors. Removable quench tray. 15-in. gooseneck lamp. 1/2-in. x 20 thread shaft. On-off switch. 11-in. x 16 1/4-in. long. 6-ft., 3-wire cord, adapter. UL listed. 110-120-volt, 60-cycle AC only. See guarantee at right. 9 KT 1958C—Shipping weight 30 pounds.....\$69.99

Same as above but without lamp and tray. 9 KT 19589C—Shipping weight 29 pounds.....\$59.99

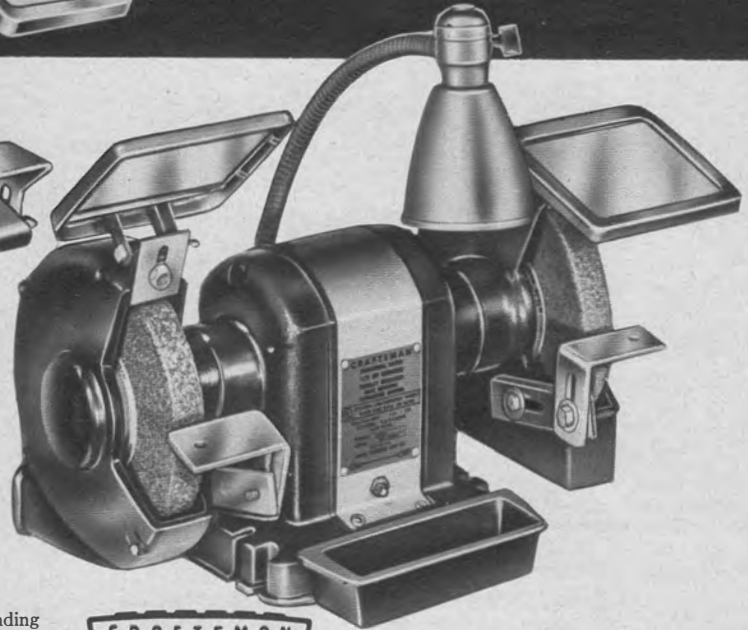

1/2-HP motor . . . two 7x1-inch wheels

***\$9999**

Capacitor-start 3450-rpm motor. Super-hard aluminum oxide grinding wheels . . . one 36-grit, one 60-grit. Flat-faced cast aluminum housing for maximum clearance . . . rubber-mounted to cut vibration. Adjustable metal-rimmed safety-glass eye shields and 2-piece all-position tool rests. Removable side guards, spark arrestors, water tray. Switch in front. 18-inch flexible gooseneck lamp. 1/2-in. x 20-thread shaft. Size 11 inches high, 18 3/4 inches long. 8-foot, 3-wire cord, adapter. UL listed. 110-120 or 230-volt, 60-cycle AC. See guarantee below. 9 KT 1959C—Shipping weight 39 pounds.....\$99.99

GRINDER GUARANTEE

We will replace grinders free of charge, if defective in material or workmanship, within the time period specified (1 year for CRAFTSMAN grinders, 90 days for grinder 9 KT 1964). This guarantee service is available by simply returning the grinder to any Sears store throughout the United States.



CRAFTSMAN® with 1/4-HP motor and two 6x1/2-inch wheels

***\$4999**

Split-phase 3450-rpm motor. Two aluminum oxide grinding wheels: one fine, one medium. Flat-faced housing, convenient on-off switch in front. Adjustable tool rests and plastic eye shields. Removable guards. 1/2-inch x 20-thread shaft. Size 10 inches high, 15 1/2 inches long. Base measures 8 3/16 inches wide, 7 1/4 inches front to back. With 6-ft., 3-wire cord, adapter. UL listed. 110-120-v., 60-c. AC. See guarantee at right. 9 KT 1940C—Shipping weight 25 pounds.....\$49.99

Sears 5-inch Electric Grinder

***\$1599**

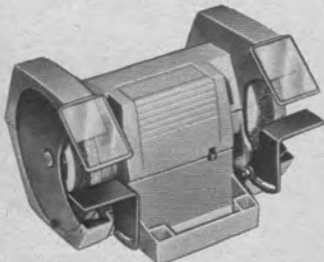

Not CRAFTSMAN. Shaded-pole motor. Self-aligning bronze bearings. Two 5x1/2-inch grinding wheels: one fine, one medium coarse. Adjustable tool rests and plastic eye shields. Convenient on-off switch. 6-foot, 3-wire cord and adapter. UL listed. 6 in. high; 9 3/4 in. long overall. 7 3/4 in. front to back. 110-120-volt, 60-cycle AC. Guaranteed for 90 days. See guarantee at right above. Shpg. wt. 12 lbs. 10 oz. 9 KT 1964.....\$15.99



CRAFTSMAN® 6-inch Belt-driven Grinder

***\$2799**

Sturdy aluminum alloy and stress-resistant polystyrene. 1 3/16-in. clearance in front of housing for grinding long workpieces. 12 1/2 x 3/8-in. shaft reduced to 1/2-in. x 20-thread at ends. 2 1/4-in. diam. stamped flanges. Two 6x3/4-in. wheels. 1 fine, 1 coarse. Wrap-around tool rests fully adjustable, up, down, in, out. Removable guards. 8 in. high, 12 1/2 in. long. 7 3/4 in. front to back. 2-in. machine pulley. Order motor separately. Guarantee above. Speed not to exceed 3450 RPM. 9 KT 6605—Shipping wt. 11 lbs.....\$27.99



CRAFTSMAN® Polishing Head

***\$1499**

Bufs and polishes metals, plastics . . . removes paint, rust . . . NOT for grinding. Die-cast aluminum housing . . . stress-resistant polystyrene base. Permanently lubricated ball bearings. 3/8 x 12 1/4-in. spindle reduced to 1/2-in. x 20-thread at ends. 2 1/4-in. diameter flanges. 6 1/4 in. high; 12 1/2 in. long; 3 3/4 in. front to back. For wheels to 6-in. diameter. 2-inch machine pulley. Order motor separately. Speed not to exceed 3450 RPM. Wt. 4 lbs. 11 oz. 9 KT 6601.....\$14.99



3/4-HP

Heavy-duty Grinder with two 8x1-inch wheels

\$129⁰⁰

Designed for continuous operation in toolrooms, service stations, machine shops, farms and ranches.

1 Our Finest. Powerful single-phase 3450-RPM capacitor motor. Super-hard aluminum-oxide grinding wheels; one 36 grit, one 60 grit; 12 3/8-inch clearance between wheels. Extra-heavy one-piece cast iron base plus dynamically-balanced rotor to cut vibration. Quench tray. Flat-faced aluminum housing for maximum work area. On-off switch in front.

Adjustable 2-piece all-position tool rests and metal-rimmed safety glass eyeshields. Removable side-guards, spark arrestors. Dual exhaust outlets. 18-inch flexible gooseneck lamp. 3/4-inch x 18-thread shaft. 11 1/8 x 20 inches long, 13 inches high. With 8-foot 3-wire cord, adapter. UL listed. 110-120 or 230-volt, 60-cycle AC. Shipped by motor carrier or express. 1-year guarantee . . . see full details of guarantee on facing page. CRAFTSMAN COMMERCIAL story, page 13. Shipping weight 58 pounds.

9 KT 1967N \$129.00

2 Pedestal Stand. For CRAFTSMAN 1/4, 1/3, 1/2-HP grinders (also 9 KT 1967N above). Heavy-duty construction. Gives solid, positive support for accurate grinding. 2 3/4-in. diam. tubular steel post. 32 1/2 in. high. Cast iron base can be bolted to floor (bolts not included). Platform pre-bored for fast mounting. Shipping weight 33 pounds.

9 KT 2964C \$24.99

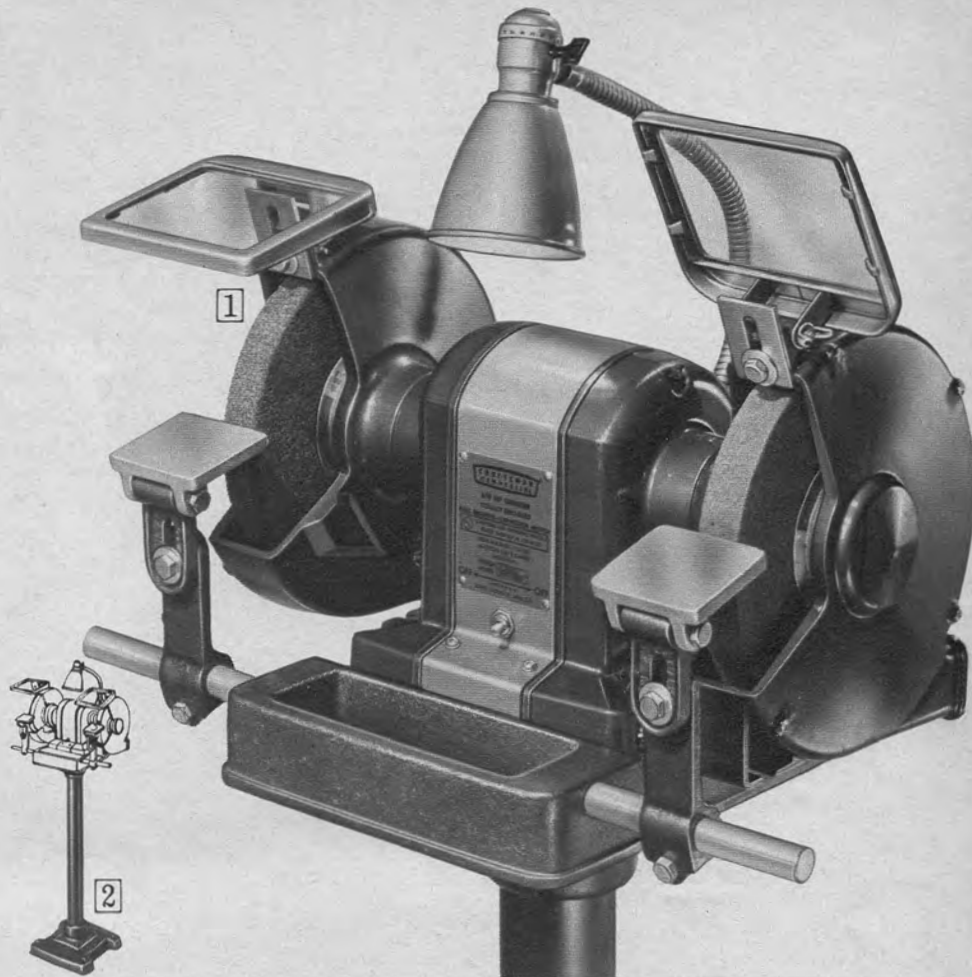

Grinder Attachment holds tools

\$12⁹⁹

For smooth, balanced sharpening of tools, blades, scissors, screwdrivers, etc. Holds work at pre-set angle for precise accuracy. Makes hollow or conventional grinding easier. Convenient guide for long knives and garden tools. 4-in. travel.

Fine feed adjustment. Strong steel and die-cast construction. Simple to assemble. Instructions. Fits CRAFTSMAN grinders except 9KT1967.

9 KT 19495—Shipping wt. 4 lbs. 15 oz. \$12.99

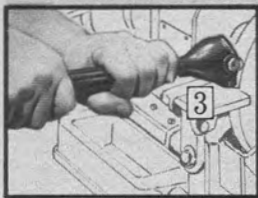
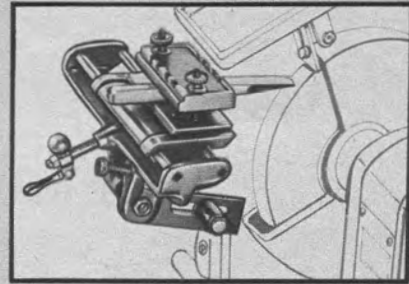

3 Grinding-wheel Dresser. High carbon-steel cutters. Dresses, shapes, removes glaze from abrasive wheels. Overall length 12 inches.

Shipping weight 2 lbs. 2 oz.
9 KT 6492 \$1.99

Extra Cutters for above. Package of 4.

Shipping weight 2 ounces.
9 KT 6495 Pkg. 29c

4 CRAFTSMAN Lamb's Wool Polishing Bonnets. Fit over sanding discs.

Catalog Number	Fits discs (linch)	Pile (in.)	Wt.	Each
9KT2520	3/2 to 4	1	3 oz.	69c
9KT2521	4 to 5/2	1	3 oz.	99c
9KT2522	5 to 6	1	4 oz.	\$1.39
9KT2523	6 to 7	1 1/4	5 oz.	1.59

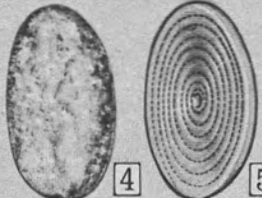

Grinding, Polishing and Cleaning Accessories

5 CRAFTSMAN Buffing Wheels. Spiral-sewed muslin; raked edges. 30 layers. 64x64-in. thread count. Fits 1/2 or 3/4-in. shafts. Use buffing compound. Use 2 or more in tandem for wider work areas.

4-in. diam. Wt. 3 oz.
9 KT 64933 69c

6-in. diam. Wt. 6 oz.
9 KT 64931 99c

8-in. diam. Wt. 8 oz.
9 KT 64932 \$1.39

6 CRAFTSMAN Buffing Compound. Set of four 3-oz. bars: emery (black); Tripoli (brown); red rouge; white rouge.

Shpg. wt. 1 lb. 8 oz.
9 KT 2896 Set 99c

CRAFTSMAN Buffing Compound. For metals and plastics. 3-ounce bar.

9 KT 2865—Shipping wt. 7 oz. 39c

White Rouge Buffing Compound. For stainless steel, aluminum, cast brass, chromium, similar finishes. 3-oz. bar.

9 KT 2860—Shipping wt. 8 oz. 39c

7 CRAFTSMAN Wire Scratch Wheels. Use on grinders, polishing heads and mandrels to remove rust and paint, deburr, etc. Use 2 or more in tandem. Widths in table are approx.

Catalog Number	Diam. (in.)	Width (in.)	Hole		Weight (lbs.oz.)	Each
			Diam.	Depth		
Coarse						
9KT64811	4	3/8	1/2	1/8	11	\$1.19
9KT64812	6	3/8	3/8	1/8	15	1.59
9KT64813	8	1/2	3/8	1/8	10	2.29
Fine						
9KT64823	4	3/8	1/2	1/8	11	1.39
9KT64824	6	3/8	3/8	1/8	15	1.99

Wide-face Coarse Wheels

9KT64834	6	1 1/2	3/8	1/8	12	3.89
9KT64835	8	1 1/2	3/8	1/8	3	5.59

1/2-in. center hole bushed for 3/8 in.
3/8-in. center hole bushed for 1/2 in.

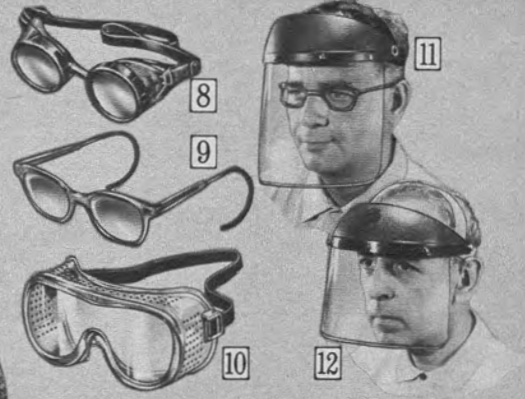

CRAFTSMAN® Safety Equipment

8 Industrial Goggles. For chipping, grinding. Adjustable plastic frames. Hardened 50mm lenses. Protective side shields.

9 KT 1860—Shipping weight 7 ounces \$2.99

Industrial Goggles. As above, but designed to fit comfortably over regular glasses.

9 KT 18615—Shipping weight 9 ounces \$3.99

9 Industrial Safety Glasses. Clear, hardened lenses. Saddle-type bridge.

9 KT 1854—Shipping weight 5 ounces \$3.99

Glasses as above but include side shields.

9 KT 1855—Shipping weight 5 ounces 4.49

10 Flexible Mask/Goggles. Grinding, chipping. .050-in. plastic lens. Fit over glasses.

9 KT 1859—Shipping weight 7 ounces \$1.59

11 Face Shield. 8x11 1/2-in. acetate window. Vulcanized fiber spark deflector. Headband adjust.

9 KT 18613—Shipping weight 1 lb. 1 oz. \$3.99

Extra Window for 9KT18613 above, 9KT18611 below.

9 KT 18614—Shipping weight 5 ounces 1.49

12 Face Shield. 6x11 1/2-in. plastic window, crown deflector. Polyethylene headgear, cross strap.

9 KT 18611—Shipping weight 15 ounces \$3.49

Extra Window for 9KT18611, 9KT18613 above.

9 KT 18612—Shipping weight 5 ounces 1.19

You can equip your entire workshop with power and hand tools from this book