

OPERATING INSTRUCTIONS AND PARTS LIST FOR

CRAFTSMAN BAND SAW

12 INCH

MODEL NUMBER 103.24260

This is the model number of your Band Saw. It will be found on a plate on the back cover. Always mention this model number when communicating with us regarding your Band Saw or when ordering parts.

HOW TO ORDER REPAIR PARTS

All parts listed herein may be ordered through SEARS, ROEBUCK AND CO. or SIMPSONS-SEARS LIMITED. When ordering parts by mail from the mail order house which serves the territory in which you live, selling prices will be furnished on request or parts will be shipped at prevailing prices and you will be billed accordingly.

WHEN ORDERING REPAIR PARTS, ALWAYS GIVE THE FOLLOWING INFORMATION AS SHOWN IN THIS LIST:

- | | | |
|---------------------|----------------------|-----------|
| 1. The PART NUMBER. | 3. The MODEL NUMBER. | 103.24260 |
| 2. The PART NAME. | 4. The NAME of item. | BAND SAW |

COAST TO COAST NATION-WIDE SERVICE FROM SEARS FOR YOUR CRAFTSMAN POWER TOOLS



SEARS, ROEBUCK AND CO. and SIMPSONS-SEARS LIMITED in Canada back up your investment with quick, expert mechanical service and genuine CRAFTSMAN replacement parts.

If and when you need repairs or service, call on us to protect your investment in this fine piece of equipment.

SEARS, ROEBUCK AND CO. — U.S.A.
IN CANADA, SIMPSONS-SEARS LIMITED

OPERATING INSTRUCTIONS AND PARTS LIST FOR BAND SAW
MODEL NUMBER 103.24260

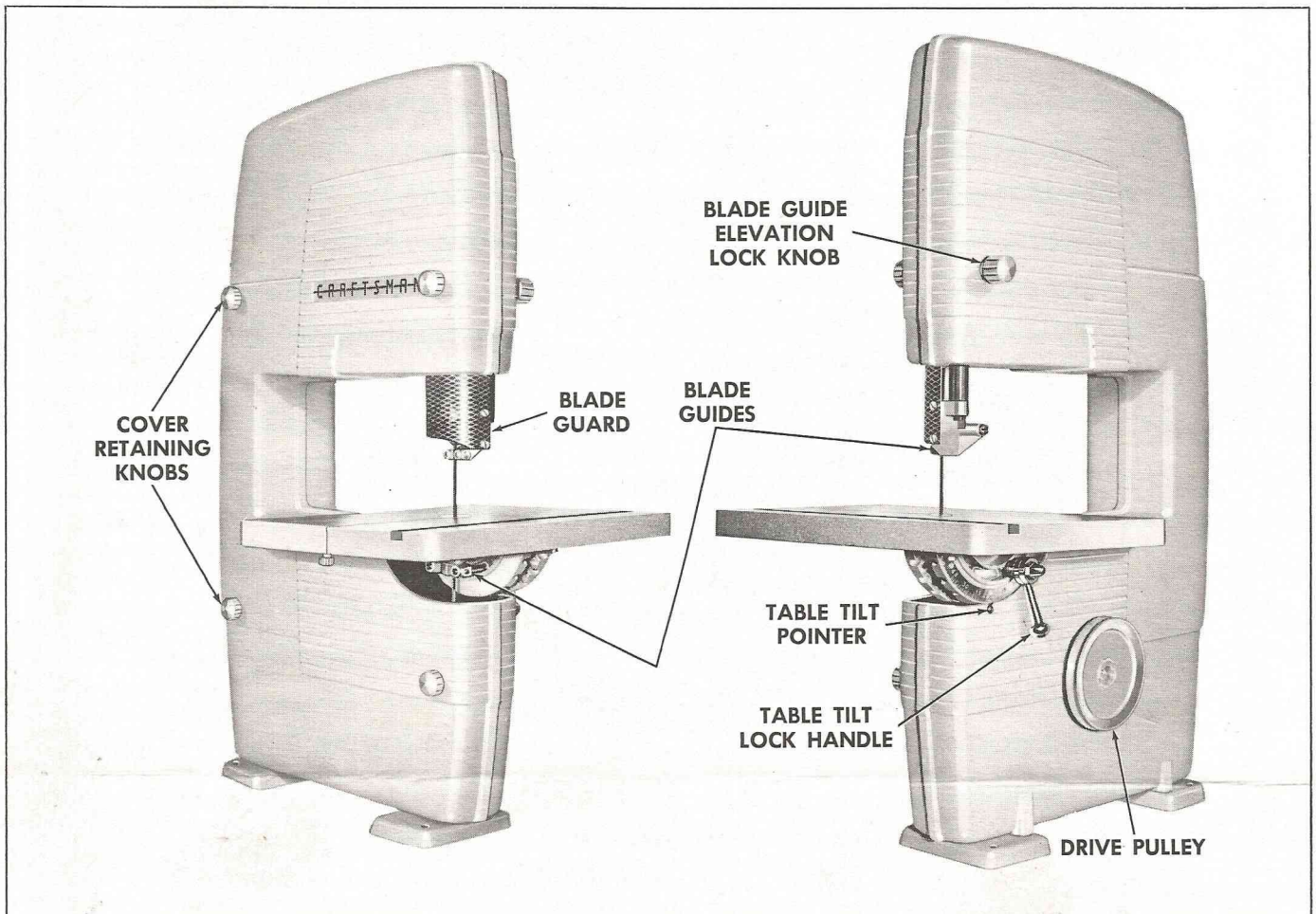

FIGURE 1

To prevent damage in shipment some of the parts were disassembled from the tool. These parts are listed below. Be sure they are all accounted for before discarding any of the packing material.

1. Saw blade, No. 4. See page 5.
2. Table and mounting bracket assembly complete; Nos. 11, 13, 16, 17, 18, 19, 21, 22, 23, 29, 30, 34, 35, 58, 59, 63, 64, 65, 66, 67, 69, 71, and 89.
3. Bag of miscellaneous small parts consisting of items No. 20, 21, 32, 62, 87, 88.

Assembly:

Remove the 4 **cover retaining knobs** and slide the cover off studs, see Fig. 1.

IMPORTANT; Place the 2 **mounting bolts**, No. 62, in the two holes of the **trunnion support bracket** and mount the **table and support bracket assembly** to the **frame** as shown in Fig. 2. Leave these 2 bolts **loose** enough to allow the entire assembly to be shifted.

Before proceeding with assembling be sure the table is locked so that the **90° stop screw**, No. 22, is

resting on the **trunnion support bracket**, No. 63. Locking of the table is accomplished with the **table tilt lock handle** as shown in Fig. 1.

Install the saw blade with the teeth pointing **down**, and **away** from the saw blade guides. Apply tension to the blade to take up the slack. Refer to paragraph under tracking.

With an accurate square resting on the table surface, see Fig. 2, square the table and mounting bracket assembly with the saw blade.

Thread leveling screw, No. 89, into bottom hole of trunnion support bracket, No. 63. Insert threaded stud, No. 87, thru leveling screw and thread into tapped hole in frame.

Place lock washer, No. 88, over stud and start the hex nut, No. 21. Adjust the leveling screw in or out until table is square with the back edge of blade (use combination square). Lock in place with hex nut.

Finish tightening the two mounting bolts, No. 62. Place the knurled screw, No. 20, in the table saw slot.

Before replacing the cover check the blade for "Tension" and "Tracking" as explained under "Adjustments".

Installation:

Three holes have been provided to secure Band Saw to bench. There are two holes in the front foot on the outside of the tool. The rear foot has one hole accessible from inside the cover.

The motor may be installed behind or below tool.

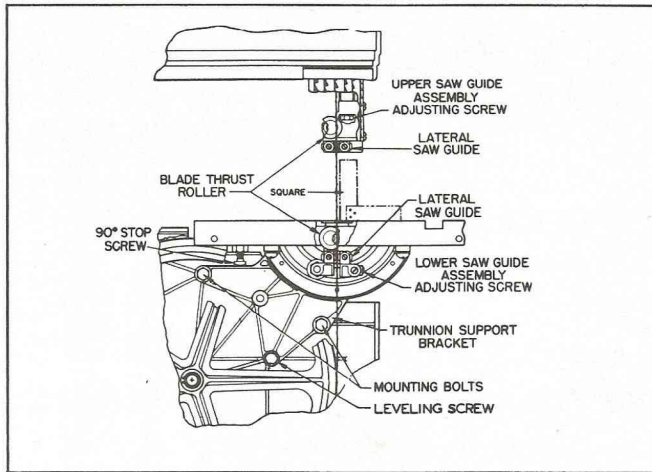

FIGURE 2

MOTOR:

A $\frac{1}{3}$ horsepower 1750 R.P.M. motor is recommended for general usage.

Install the motor so that the direction of rotation of the drive pulley, see Fig. 1, is counter-clockwise when viewed from the drive pulley side of the tool.

SPEED:

The above motor equipped with a 2-inch diameter pulley will give an arbor speed of approximately 640 R.P.M. This is recommended for general use with wood and similar material.

When purchasing the motor pulley be sure to specify the shaft diameter of your motor and that the pulley is for a $\frac{1}{2}$ -inch V-belt.

BELT:

The drive pulley is designed for use with a standard $\frac{1}{2}$ -inch V-belt. The length of this belt may be determined after the motor position has been selected by measuring with a steel tape around the outside of the pulleys, not in the grooves.

Lubrication:

A special double row ball bearing built into the drive shaft and the two single row ball bearings in the idler wheel have been packed with lubricant and sealed at the factory. They require no further attention.

The blade thrust rollers, as shown in Fig. 2, should be lubricated occasionally. Other moving and sliding parts such as the guide slide bar, No. 57, and table trunnions, Nos. 18 and 64, may require occasional lubrication to maintain smooth operation.

Controls:

The table tilt lock handle locks the table in any position from 90° to 45° with saw blade.

The table tilt pointer indicates the table angle on the calibrated trunnion scale.

The blade guides back up the blade for both lateral and direct thrust.

The blade guide elevation lock knob controls the upper assembly in relation to table surface for various work piece thicknesses.

The blade alignment screw provides a means of tilting the upper wheel for correct saw blade tracking.

The blade tension cam, No. 52, provides a quick and easy means for changing saw blades. Pull the cam handle down to release the upper wheel and loosen saw blade. Push cam handle up to reposition wheel and tighten the saw blade.

Adjustments:

Check the following points to insure proper operation.

TENSION;

Proper tension for all recommended blades is built in requiring no further attention.

TRACKING;

To operate properly the upper and lower wheels Nos. 3 and 82 must be in the same vertical plane. This position has been established in assembly of the tool. If, due to rough handling during shipment, the lower wheel has become misaligned, the proper alignment may be accomplished as follows. After assembling and tensioning the saw blade, place a straightedge across the wheels. See sketch 1. If in proper alignment, the straightedge should contact the wheels at four points A — B — C and D.

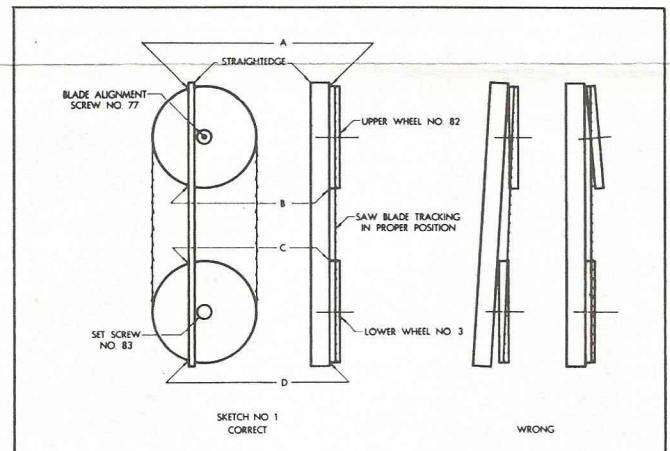

SKETCH 1

To compensate for any misalignment, loosen the set screw No. 83 and with the straightedge contacting points C and D on the lower wheel, adjust it in or out until the straightedge contacts points A and B of the upper wheel. If only one point A or B is contacted, adjust the blade alignment screw No. 77 to tilt the upper wheel until all four points are in contact. After proper alignment has been accomplished re-tighten screw No. 83 in the lower wheel.

If a $\frac{1}{8}$ " width blade is used, the alignment screw, No. 77, will require further adjustment.

GUIDES;

Saw guide assemblies are provided both above and below the table to support the blade against lateral and direct thrust.

The **upper saw guide assembly**, Fig. 3, must operate so that the distance from the back of the saw blade to the thrust roller remains the same throughout the entire up and down movement of the assembly. If adjustment is necessary remove the cover and turn the **upper saw guide bar adjusting screw**, Fig. 3, either in or out as required. When adjustment is completed lock the **adjusting screw lock nut**, Fig. 3, to maintain adjustment.

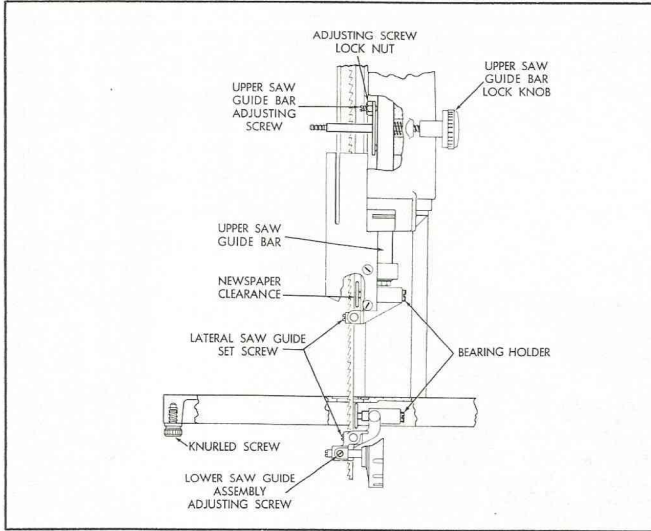

FIGURE 3

Adjust the saw guide assemblies so that the **lateral saw guides**, see Fig. 2, when adjusted, will contact the blade on the solid portion only, not on the teeth or valleys between teeth. To do this loosen the **saw guide assembly adjusting screws** (Fig. 2) and move the saw guide assemblies forward or backward as necessary. Lock the saw guide assemblies in position.

The **lateral saw guides** must be set as close as possible to the blade without binding it at any point or deflecting it sideways. Lock the set screws securing the lateral saw guides.

The **blade thrust rollers**, as shown in Fig. 2, should be set the thickness of a piece of newspaper, see Fig. 3, from the back edge of the blade. Using a screw driver, turn the bearing holder, see Fig. 3, in or out until the roller is in the correct position. The blade should touch these rollers only when cutting, not when saw is running free.

The above adjustments should result in a free running saw blade when no cutting is being done.

The **table should be square with the blade** and at the same time the pointer indicate zero on the scale. If correction is necessary it may be made with an accurate square resting on the table surface and against the saw blade. Adjust the **90° stop screw**, see Fig. 2, until correction has been made.

The **table tilt pointer**, as shown in Fig. 1, may now be readjusted to the zero mark on the scale by loosening the screw which holds the pointer to the tool.

After making adjustments on the Band Saw, check carefully by turning the mechanism by hand several revolutions before applying power.

NOTE: After a few hours of operation tighten all pulley set screws.

BLADE:

Following are several common causes of Band Saw blade breakage. Avoid these situations by frequently checking adjustments and by exercising care in operation, and you will be rewarded by an increased life and service from your blade.

Failure to bring the upper guide assembly down close to the work allows distortion of the blade which encourages breakage.

Excessive feed pressure causes the blade to ride hard on the thrust rollers causing cracking and eventual breakage. A dull blade, or one that has been improperly set or sharpened will require much greater feed pressure than a good, sharp, properly set blade.

If the lateral guides are set too close to the blade and rubbing constantly or causing blade deflection, the blade life and service are definitely shortened.

Both of the guides and the blades will be damaged if the guides touch the teeth rather than the smooth sides of the blade.

A poor weld where the blade ends are joined, or a weld that is improperly dressed leaving a bump, is often the cause of short blade life.

If the blade is allowed to rust, either on the tool or in storage, pitting caused by rust may be severe enough to cause breakage. Oil all blades before storing—wipe oil off before installing on Band Saw.

Finally, one of the most common causes of blade difficulty is the practice of cutting too sharp a radius or turning the work piece too fast when cutting a radius thus binding or twisting the blade. Following is a table showing the approximate minimum diameters which should be cut with various width blades.

BLADE WIDTH INCHES	MINIMUM DIAMETER INCHES
1/8	1/2
1/4	2
3/8	3
1/2	5

Operation:

Hold the work piece firmly against the table surface during cutting operations.

Do not force the work against the blade beyond the cutting capacity of the blade as this will make the following of the pattern extremely difficult.

Safety:

Always set the upper blade guide and guard as close to the work as possible to keep blade breakage to a minimum and to protect the operator. Always stop the tool before moving the blade guide.

ACCESSORIES for this tool are a rip fence, a miter gage, and a Slo-Speed Converter. The Slo-Speed Converter can be quickly attached to your band saw. Proper speeds are then instantly available for wood or metal cutting operations. These accessories may be purchased from your nearest Sears retail store or mail order house.

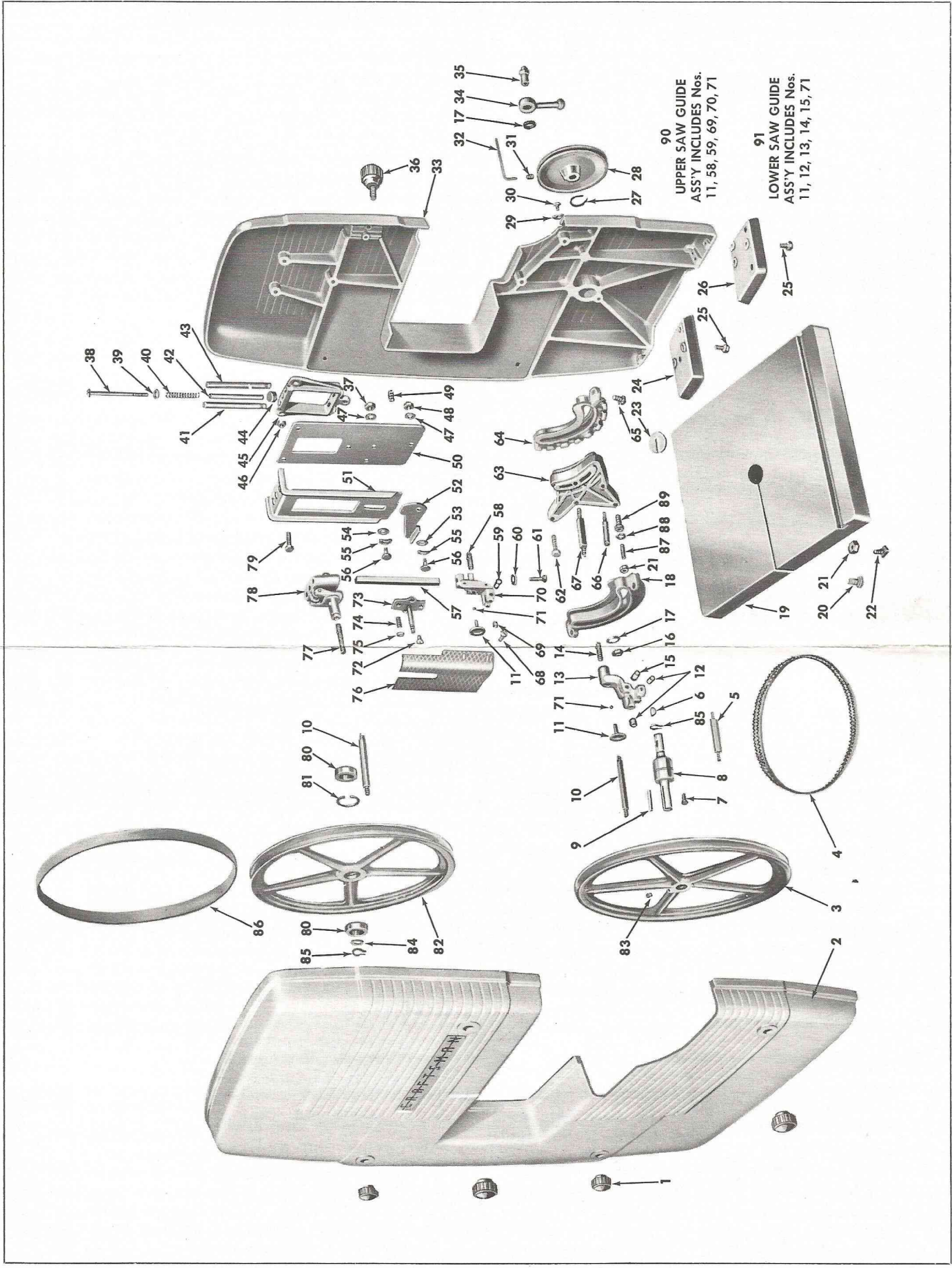

90
UPPER SAW GUIDE
ASS'Y INCLUDES Nos.
11, 58, 59, 69, 70, 71

91
LOWER SAW GUIDE
ASS'Y INCLUDES Nos.
11, 12, 13, 14, 15, 71

FIGURE 4

PARTS LIST

Do not use Key Numbers when ordering Repair Parts, always use Part Numbers.

Key No.	Part No.	Part Name	Key No.	Part No.	Part Name
1	41638	Knob	48	*X-417	Hex Nut 5/16-18
2	41510	Cover Assembly	49	41816	Guide Bar Tension Spring
3	41311	Lower Wheel	50	41722	Tensioner Support Bracket
4	**41716	Band Saw Blade 1/4 x 80" long	51	41723	Tensioner Slide Bracket
5	41625	Cover Stud — Lower Right	52	41724	Blade Tension Cam
6	X-1603	Woodruff Key — No. 606	53	X-646	Plain Washer 29/64 I.D. x 1 1/8 O.D. x 20 Ga.
7	*X-383	Machine Screw 1/4-20 x 3/8 Slot. Truss Hd.	54	X-637	Plain Washer 29/64 I.D. x 3/4 O.D. x 16 Ga.
8	41819	Bearing	55	38782	Spring Washer
9	38831	Key — Square	56	41632	Shoulder Bolt
10	41624	Cover Stud — Left	57	41617	Saw Guide Bar
11	18232	Blade Thrust Roller	58	41635	Thrust Bearing Bushing
12	*X-100	Set Screw 1/4-20 x 1/4 Slot. Hd.	59	41636	Saw Guide Pin
13	41428	Lower Saw Guide Holder	60	*X-607	Plain Washer 17/64 I.D. x 19/32 O.D. x 18 Ga.
14	41635	Thrust Bearing Bushing	61	X-2958	Thread Cutting Screw 1/4-20 x 1 1/4
15	41636	Saw Guide Pin	62	X-745	Machine Screw 5/16-18 x 1 Hex Head with External Tooth Lock Washer
16	*X-432	Hex Nut 3/8-24	63	41433	Trunnion Support Bracket
17	*X-630	Plain Washer 25/64 I.D. x 3/4 O.D. x 1/8	64	41150	Trunnion
18	41417	Trunnion	65	X-746	Machine Screw 5/16-18 x 3/4 Rd. Phil. Hd. with Internal Tooth Lock Washer
19	41217	Table	66	41616	Guide Holder Stud
20	38794	Knurled Screw	67	41621	Trunnion Lock Screw
21	*X-417	Hex Nut 5/16-18	68	*X-377	Machine Screw 10-24 x 3/8 Bind. Hd.
22	*X-309	Machine Screw 5/16-18 x 1 Sq. Hd.	69	*X-100	Set Screw 1/4-20 x 1/4 Slot Hd.
23	38416	Table Insert	70	41429	Upper Saw Guide Holder
24	41219	Foot — Rear	71	X-1308	Ball 7/32 Dia.
25	X-737	Machine Screw 5/16-18 x 3/4 Hex Hd. with External Tooth Lock Washer	72	X-382	Machine Screw 1/4-20 x 3/8 Bind. Hd.
26	41218	Foot — Front	73	41530	Cover Stud Assembly — Upper Right
27	41715	Retaining Ring	74	*X-193	Screw 1/4-20 x 1/2 Slot Head
28	**38450	Pulley with Set Screw 5" O.D. x 1/2 V-Groove x 5/8 Bore — Keyed	75	*X-420	Hex. Nut 1/4-20
29	18922	Pointer	76	41728	Guard
30	*X-516	Machine Screw #8-32 x 1/4 Rd. Hd.	77	38524	Self Locking Screw
31	*X-179	Set Screw 5/16-18 x 5/16 Soc. Hd.	78	41101	Upper Wheel Fulcrum Assembly
32	*X-1403	Hex Wrench 5/32	79	X-743	Machine Screw 5/16-18 x 1 1/4 Hex Hd. with Internal Tooth Lock Washer
33	41520	Frame	80	41818	Ball Bearing
34	38414	Table Tilt Lock Handle	81	41812	Retaining Ring
35	38417	Trunnion Lock Nut	82	41312	Idler Wheel
36	41720	Knob & Stud Ass'y.	83	*X-3609	Set Screw 5/16-18 x 1/2 Soc. Hd.
37	X-417	Hex Nut 5/16-18	84	41711	Spring Washer
38	X-571	Machine Bolt 5/16-18 x 5 1/2 Slot Rd. Hd.	85	38716	Retaining Ring
39	*X-601	Plain Washer 11/32 I.D.	86	41815	Tire
40	41822	Spring	87	41639	Threaded Stud
41	41631	Upper Wheel Guide Rod	88	X-611	Lock Washer 5/16 Am. Std.
42	41725	Blade Tension Spacer	89	41642	Leveling Screw
43	41631	Upper Wheel Guide Rod	90	41107	Upper Saw Guide Assembly
44	41823	Bumper	91	41106	Lower Saw Guide Assembly
45	41426	Upper Wheel Support Bracket		41939	Instruction Sheet and Parts List
46	41637	Spacer			
47	*X-624	Plain Washer 11/32 I.D. x 1-1/16 O.D. x 1/16			

*Standard hardware items — may be purchased locally.

**Items are regular stock in Sears hardware department and mail order houses.

May also be ordered as repair parts by part number provided.

This sheet is intended for instruction and repair parts only and is not a packing slip.
The parts shown and listed may include accessories not necessarily part of this tool.