

Sears

OWNERS
MANUAL

MODEL NO.
315.25710

CAUTION:
Read Rules for
Safe Operation
and Instructions
Carefully

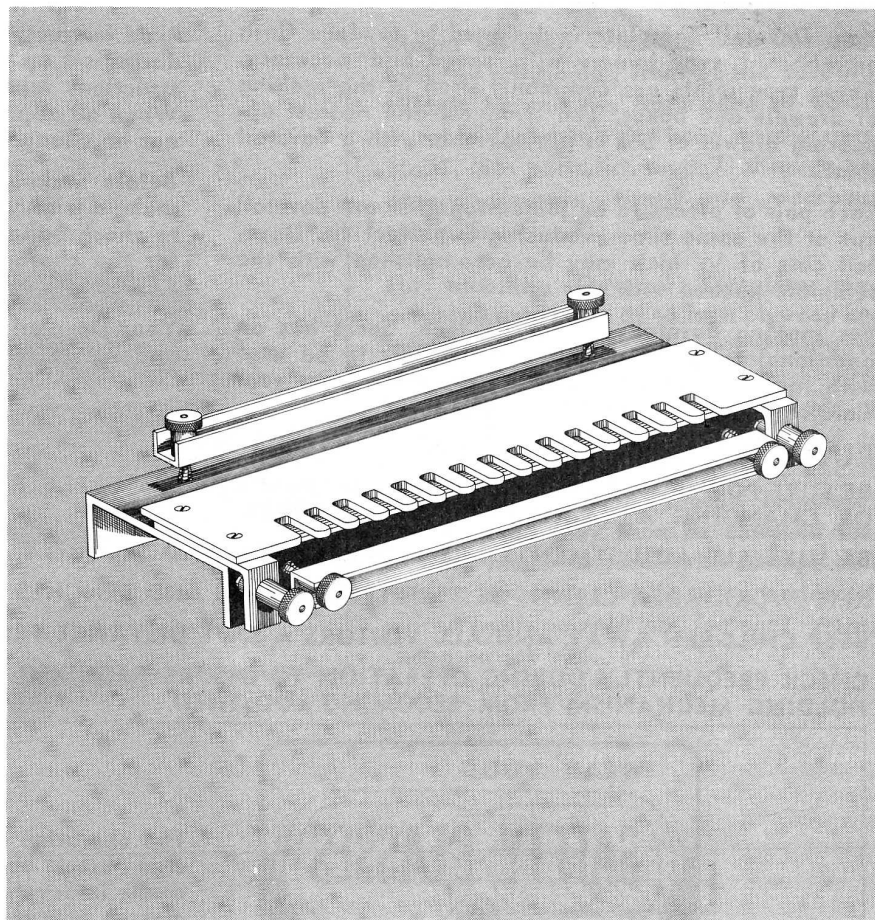

CRAFTSMAN®

DOVETAIL TEMPLATE

(FOR USE WITH ROUTER MODEL NOS. 17350, 17360,
17370, 17380, 25031, 25060, 25066 AND 25070)

Introduction
Operation
Repair Parts

Sold by SEARS, ROEBUCK AND CO., Chicago, IL 60684 U.S.A.
and SIMPSONS-SEARS LIMITED, Toronto, Ontario, Canada

introduction

Your Dovetail Template is designed to produce flush or rabbeted type joinery with speed and accuracy. These type joints are commonly used in the making of drawers and boxes. The strongest and neatest appearing drawer or box is put together with a dovetail joint.

Each pair of pieces to be joined together are dovetail cut at the same time producing a perfect fit. Dovetail cuts of $\frac{1}{2}$ inch may be accomplished with the template packed with this unit.

For making dovetail cuts of $\frac{1}{4}$ inch, Sears has an additional template designed exclusively to be used with this unit. This template is available from your Catalog Order House or Retail Store.

RULES FOR SAFE OPERATION

BE SURE POWER CORD IS DISCONNECTED FROM POWER SUPPLY BEFORE ASSEMBLING, SERVICING OR CHANGING ATTACHMENTS, BITS, CUTTERS, ETC.

BE SURE ALL ADJUSTMENTS ARE PROPERLY SET AND SECURELY FASTENED.

KEEP WORK AREA CLEAN, AS CLUTTERED AREAS AND BENCHES INVITE ACCIDENTS.

KEEP CHILDREN AWAY AND ALL VISITORS A SAFE DISTANCE FROM THE WORK AREA.

CHECK FREQUENTLY DURING OPERATION TO INSURE REQUIRED POSITION AND TO PREVENT HOLDING MECHANISM FROM BECOMING LOOSE.

Read instructions completely and carefully before and during set up and making adjustment alterations. Instructions must be followed closely for best results. When all adjustments are properly made, they should not be changed until all dovetails are made.

Before making the final joint in the finished work, make a trial cut on two scrap pieces of the same wood to check adjustments of attachment and compensate for the characteristics of the particular wood being worked.

Your Dovetail Template is packaged fully assembled and set up for making flush $\frac{1}{2}$ inch joints.



The operation of any power tool can result in foreign objects being thrown into the eyes, which can result in severe eye damage. Always wear safety glasses or eye shields before commencing power tool operation. We recommend Wide Vision Safety Mask for use over spectacles, or standard safety glasses . . . available at Sears retail or catalog stores.

operating

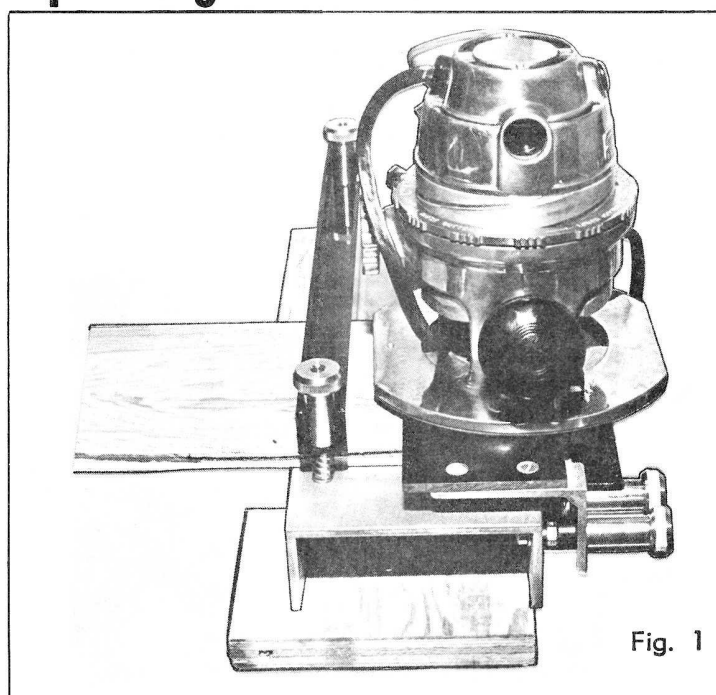

Fig. 1

MOUNTING

This Dovetail Template is designed for making flush or rabbeted $\frac{1}{2}$ inch dovetail joints using Craftsman Routers Model Numbers 315.-17350, 315.17360, 315.17370, 315.17380, 315.25031, 315.25060, 315.25066 and 315.-25070 with Adapter and Guide Bushings Catalog Number 25059 or 25069 and Dovetail Cutter Catalog Number 25531. When using router Model Number 315.25031, flat side of router base must be parallel to top clamping bar of Dovetail Template to allow proper depth of cut when routing dovetail joints (See Fig. 1).

For proper assembly of the Guide Bushings to your Router consult the operating instructions of the Adapter and Guide Bushings which you are using.

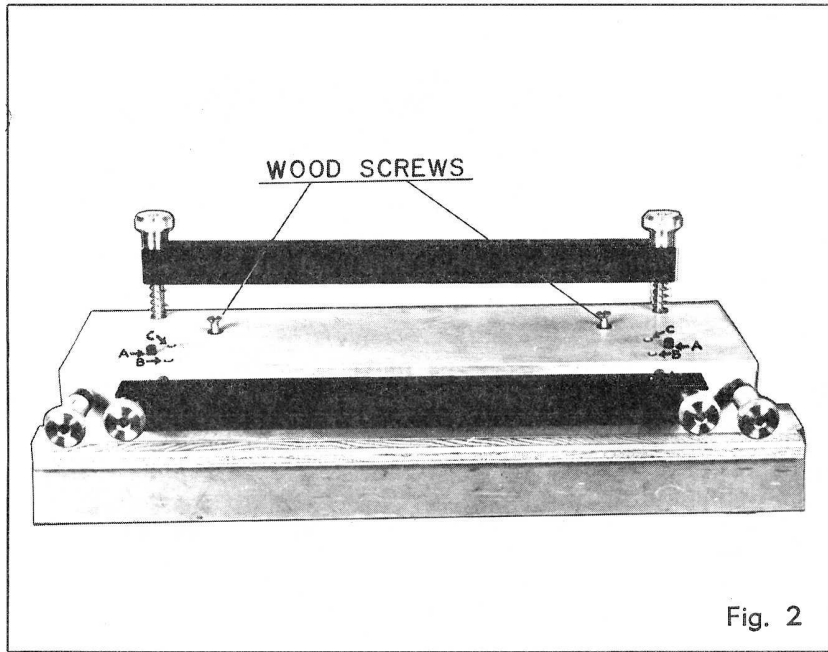
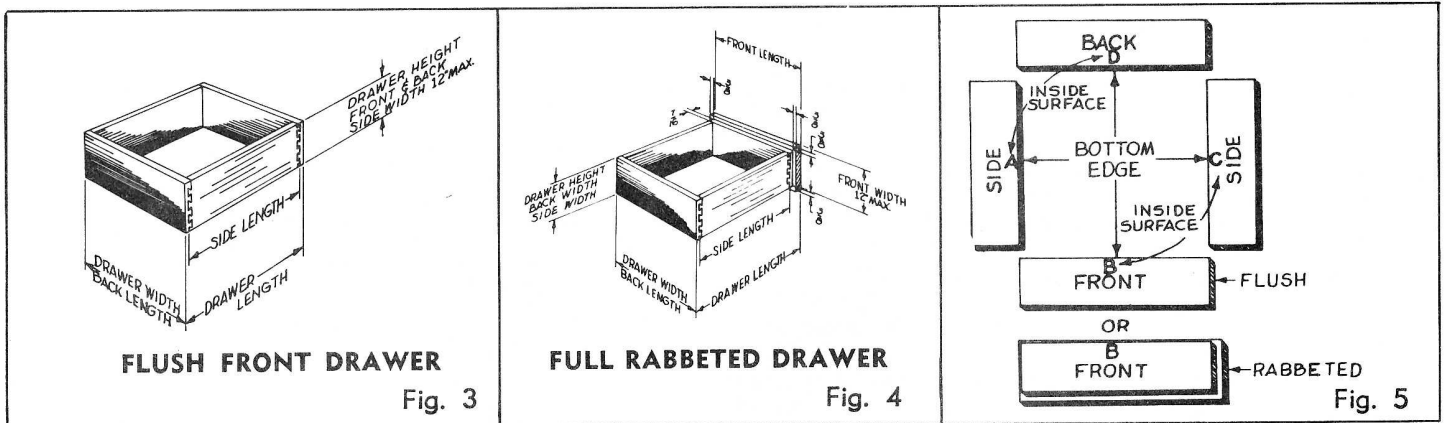

Fig. 2

Mount Dovetail Template onto workbench or table by positioning front of the base flush or slightly beyond the front edge of workbench or table. Insert two flat head wood screws, Key No. 1, (See parts list, page 7) through holes in base and secure firmly into workbench or table (See Fig. 2).

For mobility, Dovetail Template may be mounted onto piece of $\frac{3}{4}$ inch plywood approximately six inches wide and twenty inches long. Position front of base flush with the front and equidistant from the ends of the board and insert two flat head wood screws Key No. 1, through holes in base and secure firmly into plywood. Dovetail Template with wooden base may then be clamped securely to work bench or table with clamps or other holding apparatus while using and easily removed upon completion for easy storage or changing job site.



FLUSH FRONT DRAWER

Fig. 3

FULL RABBETED DRAWER

Fig. 4

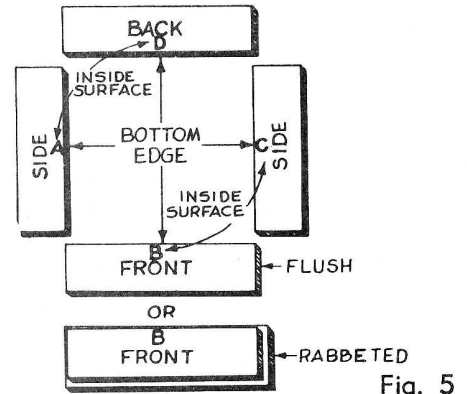

Fig. 5

SECTION	RECOMMENDED THICKNESS	LENGTH	WIDTH
Back	$\frac{1}{2}$ " to $\frac{3}{4}$ "	Width of opening less clearance	Height of opening less clearance
Sides	$\frac{3}{8}$ " to $\frac{3}{4}$ "	Depth of opening less clearance less back thickness	Same as Back
Bottom	$\frac{1}{4}$ " to $\frac{3}{8}$ "	Length of side less $\frac{1}{4}$ "	Length of back plus $\frac{1}{2}$ " less 2 times side thickness
Flush Front	$\frac{1}{2}$ " to $\frac{3}{4}$ "	Same as Back	Same as Back
$\frac{3}{8}$ Inch Rabbeted Front	$\frac{3}{4}$ "	Back length plus $\frac{3}{4}$ "	Back width plus $\frac{3}{4}$ "

NOTE: Front, back and sides should be grooved $\frac{1}{4}$ inch deep to receive bottom piece and may be done before or after dovetailing. If groove depth is more or less than $\frac{1}{4}$ inch, bottom dimensions must be altered to compensate.

FLUSH FRONT DRAWER OR BOX

SET-UP

IMPORTANT—BE SURE POWER CORD IS DISCONNECTED FROM POWER SUPPLY. Attach guide bushing with 7/16" pilot diameter to router base following instructions supplied with Adapter and Guide Bushings.

Insert the dovetail cutter bit through the guide bushings and into chuck collet at least 1/2 inch and tighten carefully. Adjust base height adjustment on router until the cutter extends 17/32 inch below the router base.

Insert four (4) stop screws into threaded holes (A) into top and front of dovetail base and tighten screws firmly (See Fig. 6).

Mark the boards for the drawer or box on the inside with identifying letters near bottom edge (See Fig. 5). The reverse sides of the board will be the outside of the finished drawer or box. The outside of the boards are always clamped towards the dovetail base and all pieces are routed in an "inside-out" position. They are reversed to assemble. The material for front (B) and back (D) should be the same size and should be cut to fit the opening neatly. The side pieces (A and C) should also be the same size. (See chart on page 3 for computing proper sizes and recommended material thicknesses.)

Insert board (A) between front clamping bar and front surface of dovetail base with bottom edge toward left stop screw. Temporarily clamp board (A) "inside-out" to the left front of the fixture so that it extends above the base (See Fig. 7). This is done to assist in properly positioning of board (B).

Insert board (B) between top clamping bar and top surface of dovetail base with bottom edge against left stop screw and flush with extended portion of board (A). Tighten top clamp knobs (E) to hold board (B) securely. Attach dovetail template (F) to the dovetail base with spacers (G) located inside brackets (See Fig. 8). Holding template flat on boards with one hand, tighten template clamp knobs (H) securely. Be sure Template finger ends are parallel to edge of board (B) to assure even fit after cutting. Relocate board (A) so that it is flush with the top of board (B) and against stop screw in left front of dovetail base. Tighten front clamp knobs (I) to hold board (A) securely.

ROUTING

To make sure all adjustments and settings are as required, it is best to first make a trial cut on two pieces of scrap lumber of the same wood that is to be used. Allowance should be made in fit of dovetail joint for gluing when completed joints are assembled. A "too tight" condition in fit will force glue out of dovetail joint causing a dry joint.

Place Router with base resting flat on dovetail template so that the guide bushing contacts along the end of teeth on template and cutter engages along the edge of board (A). Make a straight cut from right to left across board (A, See Fig. 9). This is done to prevent chipping the wood when the Router is moved in and out of the fingers of the dovetail template.

USE CAUTION WHEN OPERATING ROUTER AT EITHER EXTREME END OF DOVETAIL TEMPLATE. DOVETAIL CUTTER BIT MAY MAKE CONTACT WITH ANGLE BRACKET IF MOVED TOO FAR OUTSIDE FIRST OR FINAL CUT.

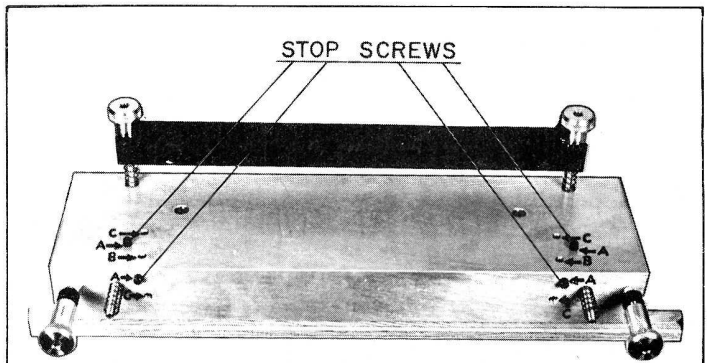

Fig. 6

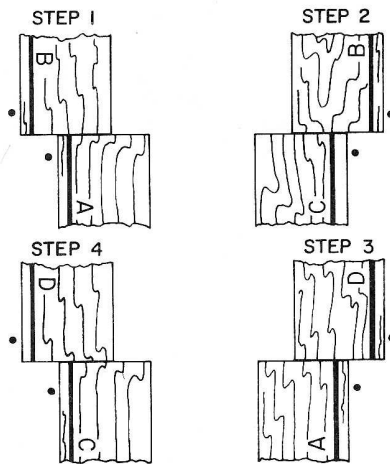
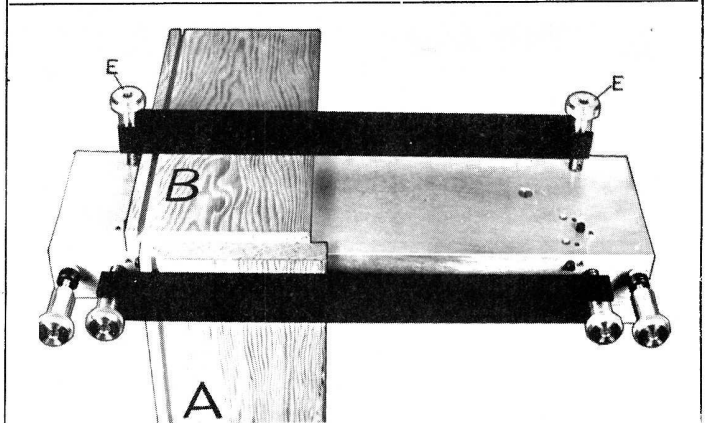

Fig. 7

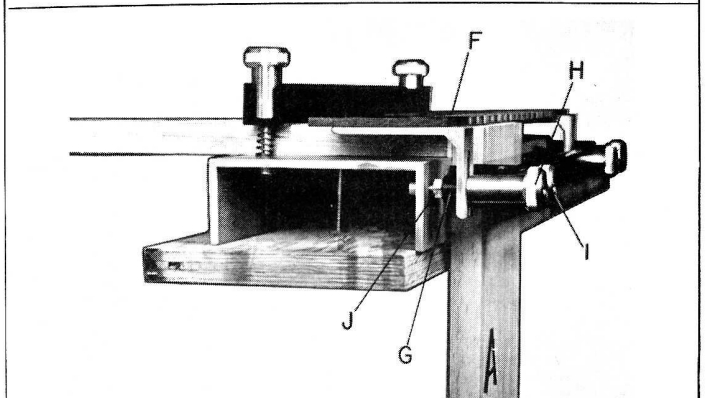

Fig. 8

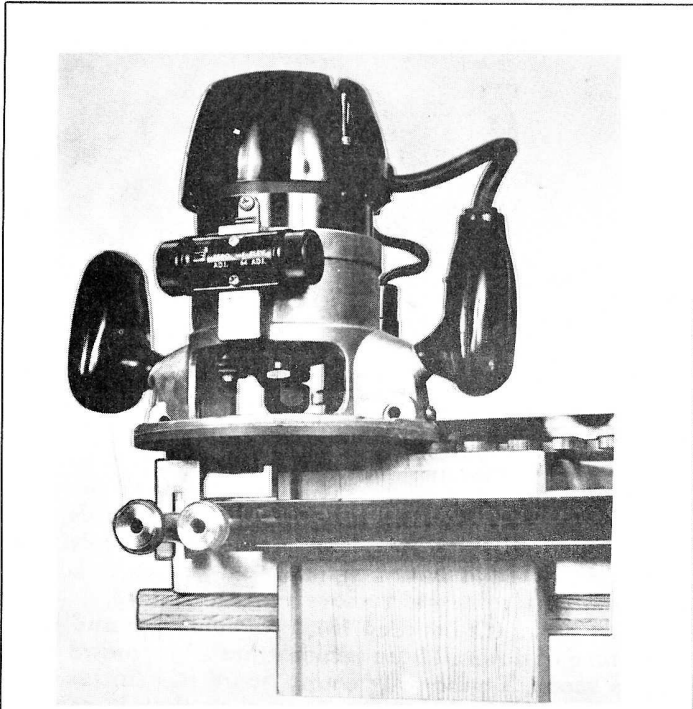

Fig. 9

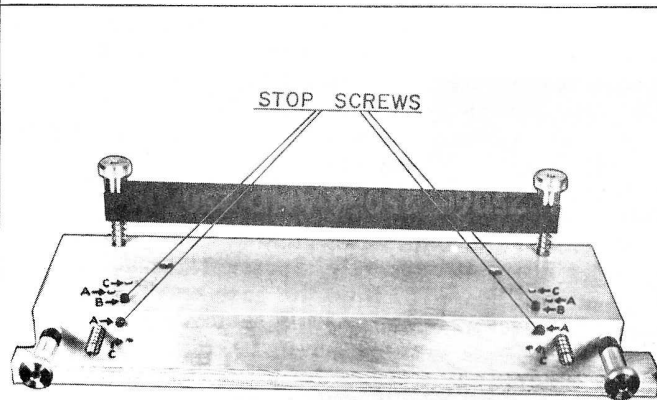

Fig. 10

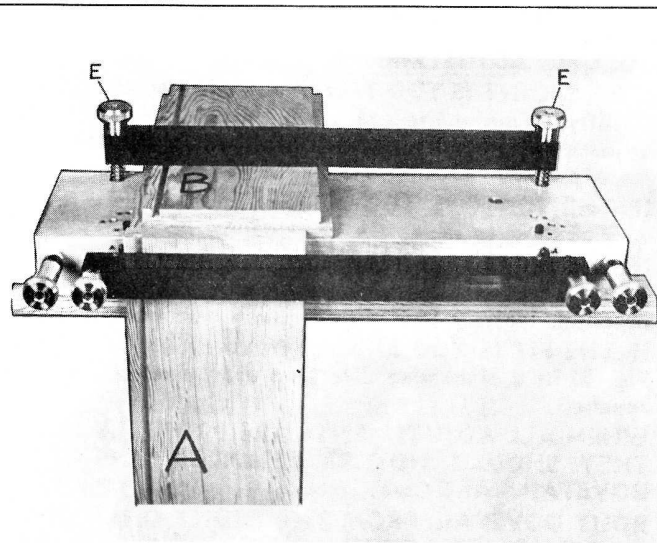

Fig. 11

Cut the dovetail joint, feeding the Router from left to right until the complete edge is accomplished. Before removing the Router from the dovetail template, recut the dovetail, moving the Router from right to left to correct any imperfections.

When the dovetail joint is completed wait until cutter bit has stopped completely before removing the Router from the dovetail template. This precaution will prevent damage to the template. When removing the Router, it should not be lifted but should be moved toward the operator until clear.

Loosen all clamp screws and remove routed sections. Insert board (C) between front clamping bar and front surface of dovetail base with bottom edge toward right stop screw. Temporarily clamp board (C) "inside-out" to the right front of the fixture so that it extends above the base. This is done to assist in properly positioning of board (B).

Insert board (B) between top clamping bar and top surface of dovetail base with bottom edge against right stop screw and flush with extended portion of board (C). Tighten top clamp knobs to hold board (B) securely. Attach dovetail template to the dovetail base with spacers located inside brackets. Holding template flat on boards with one hand, tighten template clamp knobs securely. Relocate board (C) so that it is flush with the top of board (B) and against stop screw in right front of dovetail base. Tighten front clamp knobs to hold board (C) securely. Cut dovetail joint as described above.

Loosen all clamp screws and remove routed sections. To dovetail two remaining corners, repeat above procedure by positioning boards (A and D) on the right side of base with bottom edges against right stop screws. Then position boards (C and D) on left side of base with bottom edges against left stop screws.

MAKING ADJUSTMENTS

IF THE JOINT IS TOO TIGHT, raise the cutter bit very slightly to make the cut more shallow. (Follow depth adjustment instruction as described in Router Owners Manual.)

IF THE JOINT IS TOO LOOSE, lower the cutter bit very slightly to make the cut deeper.

IF THE FIT IS TOO DEEP, turn lock nut (J, See Fig. 8) in a counter-clockwise direction until desired depth is reached. (Adjust lock nuts equally and carefully.)

IF THE FIT IS TOO SHALLOW, turn lock nut (J, See Fig. 8) in a clock-wise direction until desired depth is reached.

WHEN ALL ADJUSTMENTS ARE PROPERLY MADE, THEY SHOULD NOT BE CHANGED UNTIL ALL DOVETAILS ARE CUT.

ROUT DOVETAIL FROM THE FRONT ONLY — DO NOT RAISE OR LOWER ROUTER OR CUTTER BIT WHILE BIT IS BETWEEN DOVETAIL TEMPLATE FINGERS, KEEP ROUTER BASE FLAT AGAINST TEMPLATE.

RABBETED FRONT DRAWER

SET-UP

IMPORTANT—BE SURE POWER CORD IS DISCONNECTED FROM POWER SUPPLY. Attach guide bushing with 7/16" pilot diameter to router base following instructions supplied with Adapter and Guide Bushings.

Insert the dovetail cutter bit through the guide bushing and into chuck collet at least 1/2 inch and tighten carefully. Adjust base height adjustment on router until the cutter extends 17/32 inch below the router base. Insert two (2) stop screws into threaded holes (B) on top of dovetail base and two (2) stop screws into threaded holes (A) in front of dovetail base. Tighten stop screws securely (See Fig. 10).

Mark the boards for the drawer on the inside with identifying letters near bottom edge (See Fig. 5). The reverse sides of the board will be the outside of the finished drawer. The outside of the boards are always clamped toward the dovetail base and all pieces are routed in an "inside-out" position. They are reversed to assemble. The front piece (B) should be $\frac{3}{4}$ " longer and $\frac{3}{4}$ " wider than the opening less clearance. The rabbet cut on the inside of the front board should be $\frac{3}{8}$ " wide and $\frac{7}{16}$ " deep. The side pieces (A and C) should be the same size. (See chart on page 3 for computing proper sizes and recommended material thicknesses.)

Insert board (A) between front clamping bar and front surface of dovetail base with bottom edge toward left stop screw. Temporarily clamp board (A) "inside-out" to the left front of the fixture so that it extends above the base (See Fig. 11). This is done to assist in properly positioning of board (B).

Insert board (B) between top clamping bar and top surface of dovetail base with bottom edge against left stop screw and flush with extended portion of board (A). Tighten top clamp knobs (E) to hold board (B) securely. Attach dovetail template (F) to the dovetail base with spacers (G) located inside brackets (See Fig. 8). Holding template flat on boards with one hand, tighten template clamp knobs (H) securely. Be sure Template finger ends are parallel to edge of board (B) to assure even fit after cutting. Relocate board (A) so that it is flush with the top board (B) and against stop screw in left front of dovetail base. Tighten front clamp knobs (I) to hold board (A) securely. Loosen top clamp knobs (E) and remove board (B) from the base and replace with a piece of scrap lumber of the same wood. This provides support in area of cut in board (A) which prevents splintering as the cutter bit moves through cut.

USE CAUTION WHEN OPERATING ROUTER AT EITHER EXTREME END OF DOVETAIL TEMPLATE. DOVETAIL CUTTER BIT MAY MAKE CONTACT WITH ANGLE BRACKET IF MOVED TOO FAR OUTSIDE FIRST OR FINAL CUT.

ROUTING

To make sure all adjustments and settings are as required, it is best to first make a trial cut on two pieces of scrap lumber of the same wood that is to be used. Allowance should be made in fit of dovetail for gluing when completed joints are assembled. A "too tight" condition in fit will force glue out of dovetail joint causing a dry joint.

Place Router with base resting flat on dovetail template so that the guide bushing engages along the edge of board (A). Make a straight cut from right to left across board (A, See Fig. 9). This is done to prevent chipping the wood when the Router is moved in and out of the fingers of the dovetail template.

Cut the dovetail joint, feeding the Router from left to right until the completed edge is accomplished. Before removing the Router from the dovetail template, recut the dovetail, moving the Router from right to left to correct any imperfections.

When the dovetail joint is completed wait until cutter bit has stopped completely before removing the Router from the dovetail template. This precaution will prevent damage to the template. When removing the Router, it should not be lifted but should be moved toward the operator until clear. Loosen template clamp knobs and remove dovetail template. Without removing board (A) loosen top clamp knobs (E), remove scrap piece and replace with piece that is to be finished front board (B), flush with edge of board (A).

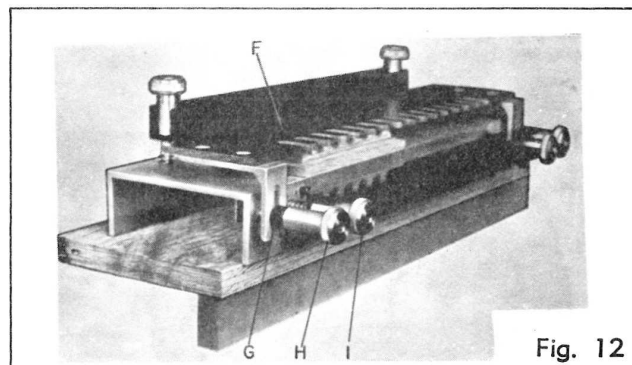

Fig. 12

Tighten top clamp knobs (E) firmly. After board (B) is properly positioned, loosen front clamp knobs (I) and remove board (A). Attach dovetail template (F) to the dovetail base with spacers (G) located outside brackets (See Fig. 12). Holding template flat on boards with one hand, tighten template knobs (H) securely. Cut dovetail joint in board (B) as a single piece. Loosen all clamp screws and remove routed sections.

Insert board (C) between front clamping bar and front surface of dovetail base with bottom edge toward right stop screw. Temporarily clamp board (C) "inside-out" to the right front of the fixture so that it extends above the base. This is done to assist in properly positioning of board (B).

Insert board (B) between top clamping bar and top surface of dovetail base with bottom edge against right stop screw and flush with extended portion of board (C). Tighten top clamp knobs to hold board (B) securely. Attach dovetail template to the dovetail base with spacers located inside brackets. Holding template flat on boards with one hand, tighten template clamp knobs securely. Relocate board (C) so that it is flush with the top of board (B) and against stop screw in right front of dovetail base. Tighten front clamp knobs to hold board (C) securely. Loosen top clamp knobs and remove board (B) from the base and replace with a piece of scrap lumber of the same wood. This provides support in area of cut in board (C) which prevents splintering as the cutter bit moves through cut. Cut dovetail joint as described above.

Loosen all clamp screws and remove routed sections. Dovetail cuts in board (D) and boards (A and C) may be accomplished by following instructions as described under "FLUSH FRONT DRAWER OR BOX."

MAKING ADJUSTMENTS

IF THE JOINT IS TOO TIGHT, raise the cutter bit very slightly to make the cut more shallow. (Follow depth adjustment instructions as described in Router Owners Manual.)

IF THE JOINT IS TOO LOOSE, lower the cutter bit very slightly to make the cut deeper.

IF THE FIT IS TOO DEEP, turn lock nut (J, See Fig. 8) in a counter-clockwise direction until desired depth is reached. (Adjust lock nuts equally and carefully).

IF THE FIT IS TOO SHALLOW, turn lock nut (J, See Fig. 8) in a clockwise direction until desired depth is reached.

WHEN ALL ADJUSTMENTS ARE PROPERLY MADE, THEY SHOULD NOT BE CHANGED UNTIL ALL DOVETAILS ARE CUT.

ROUT DOVETAIL FROM THE FRONT ONLY — DO NOT RAISE OR LOWER ROUTER OR CUTTER BIT WHILE BIT IS BETWEEN DOVETAIL TEMPLATE FINGERS. KEEP ROUTER BASE FLAT AGAINST TEMPLATE.

DOVETAIL TEMPLATE—MODEL NUMBER 315.25710

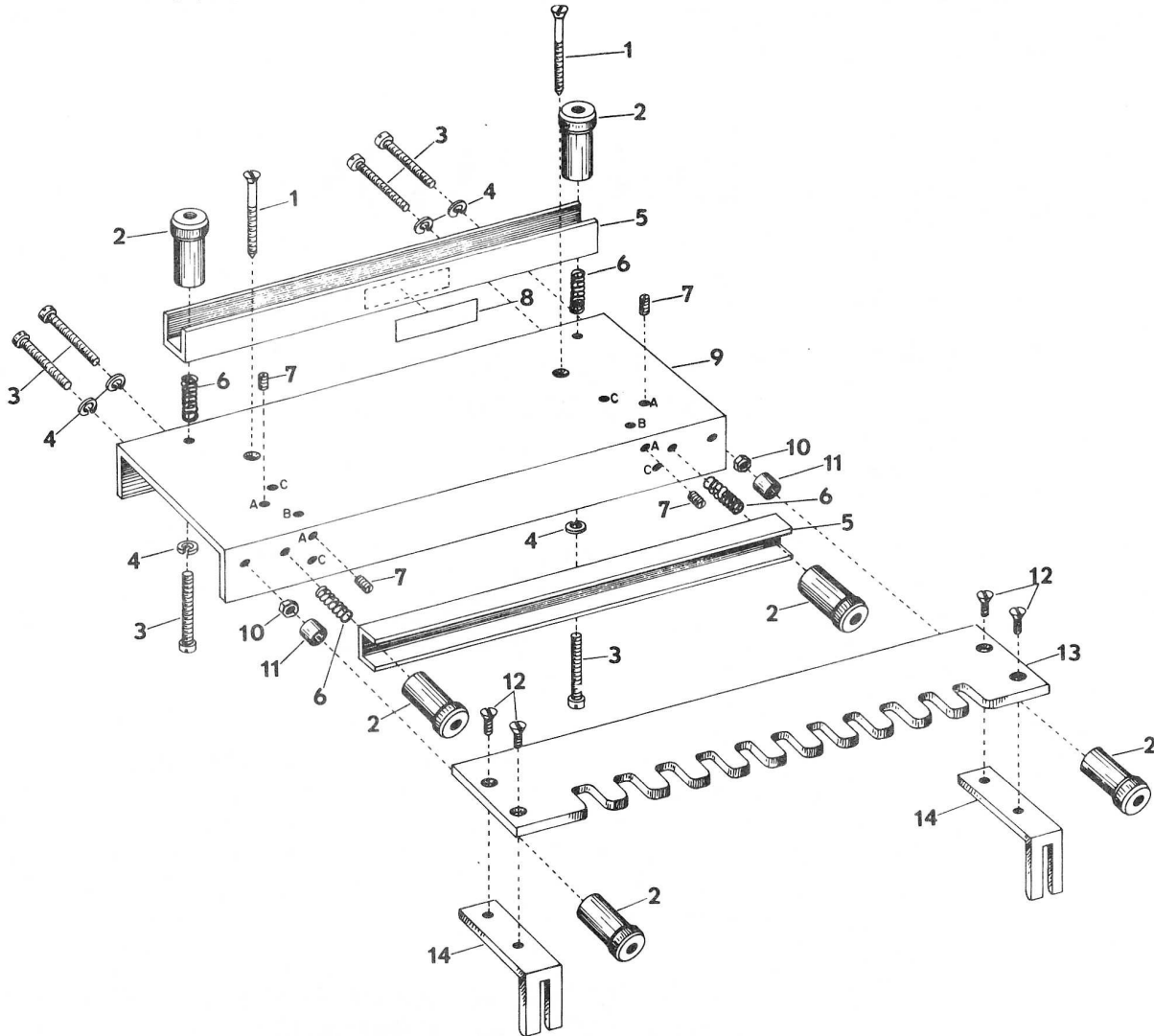

The Model Number will be found on a plate attached to the front of the top clamping bar. Always mention the Model Number in all correspondence regarding the **DOVETAIL TEMPLATE** or when ordering repair parts.

SEE BACK PAGE FOR PARTS ORDERING INSTRUCTIONS

PARTS LIST

Key No.	Part Number	Description	Quan.	Key No.	Part Number	Description	Quan.
1	1-714784-03	*Wood Screw (#12 x 2-3/4 Flat Hd.)	2	8	1-616550-01	Nameplate	1
2	1-616656-02	Knob	6	9	4-616543-04	Base	1
3	1-876368-23	Screw (1/4-20 x 1-3/4 Fil. Hd.)	6	10	1-606162-01	Lock Nut (1/4-20)	2
4	1-703473-34	Lock Washer (1/4)	6	11	1-616564-02	Spacer	2
5	3-616547-04	Clamping Bar	2	12	1-930443-04	*Screw (#10-24 x 3/8 Flat Hd.)	4
6	1-714801-00	Spring	4	13	3-616544-01	Dovetail Template	1
7	1-616549-02	Stop Screw	4	14	2-616548-04	Angle Bracket	2
					EN-632	Instruction Sheet	

*Standard Hardware Item, May Be Purchased Locally

Sears

OWNERS
MANUAL

MODEL NO.
315.25710

HOW TO ORDER
REPAIR PARTS

CRAFTSMAN[®]

DOVETAIL TEMPLATE

(FOR USE WITH ROUTER MODEL NOS. 17350, 17360,
17370, 17380, 25031, 25060, 25066 AND 25070)

The Model Number will be found on the plate attached to the front of the top clamping bar. Always mention the Model Number when requesting service or repair parts for your Dovetail Template.

All parts listed herein may be ordered from any SEARS, ROEBUCK AND CO. or SIMPSONS-SEARS LIMITED retail or catalog store. If the parts you need are not stocked locally, your order will be electronically transmitted to a Sears Repair Parts Distribution Center for expedited handling.

WHEN ORDERING REPAIR PARTS, ALWAYS GIVE THE FOLLOWING INFORMATION:

1. PART NUMBER
2. PART DESCRIPTION
3. MODEL NUMBER
315.25710
4. NAME of ITEM—
DOVETAIL
TEMPLATE

Your Sears merchandise takes on added value when you discover that Sears has over 2000 Service Units throughout the country.

Sold by SEARS, ROEBUCK AND CO., Chicago, IL 60684 U.S.A.
and SIMPSONS-SEARS LIMITED, Toronto, Ontario, Canada