

**OPERATION
AND
MAINTENANCE**

OF THE

618 MICROMASTER

SURFACE GRINDING MACHINES

Brown & Sharpe

Price \$2.75

OPERATION AND MAINTENANCE
of the
618 MICROMASTER
SURFACE GRINDING MACHINES



BROWN & SHARPE MFG. CO.
PRECISION PARK, NORTH KINGSTOWN, R. I., U. S. A.

FOREWORD

The purpose of this book is to give a thorough working knowledge of the Brown & Sharpe 618 Micromaster Surface Grinding Machine.

The Operator and Set-up Man will need to be thoroughly familiar with the information given in Chapter III. It includes a detailed explanation of each set-up adjustment and operating control, instructions on mounting and truing grinding wheels and suggestions on set-up and operation. Many additional suggestions are given in the next chapter which illustrate and describe typical operations. Chapter VII outlines the points to be considered in selecting grinding wheels.

The Maintenance Man will be particularly interested in Chapter V. This chapter covers installation and maintenance, including disassembling and reassembling of the plain-bearing spindle unit. Familiarity with the facts presented in Chapter III will also prove of value to the maintenance man.

As Brown & Sharpe is constantly improving the design of its machines, there may be some instances where this book differs somewhat from the machine that you are concerned with.

★ ★ ★ ★ ★ ★

CONTENTS

	PAGE
CHAPTER I	
Installing or Relocating the Machine	5
CHAPTER II	
Operating Controls and Principal Parts	6
Power Table Travel and Power Cross Feed (6) ; Hand Table Travel and Hand Cross Feed(7).	
CHAPTER III	
Set-up Adjustments	8
Wheel Spindle (8) ; Care and Use of Grinding Wheels (9) ; Longitudinal Table Travel (10) ; Cross Feed (11) ; Suggestions on Set-up and Operation (12).	
CHAPTER IV	
Typical Operations	13
Representative Set-ups Illustrated and Described.	
CHAPTER V	
Maintenance	16
Lubrication (16) ; Wheel Spindle (16) ; Removing the Spindle (16) ; Antifriction-Bearing Spindle Unit (16) ; Plain-Bearing Spindle Unit (16) ; Disassembling and Repairing the Plain-Bear- ing Spindle Unit (17) ; Reassembling the Plain-Bearing Spindle Unit (18) ; Replacing the Spindle Bearing in the Machine (19) ; Possible Sources of Grinding Troubles (19) ; Table and Cross Feed Mechanisms (19) ; Electrical Controls (19).	
CHAPTER VI	
Hydraulic System	20
Cleaning Hydraulic Reservoir (20) ; Adjustment of Pressure Relief Valves (20) ; Hydraulic Operation (20) ; Table Circuit (21) ; Table Reversing (21) ; Cross Feed Circuit (21) ; Power Down Feed Arrangement (21) ; Lubrication (21) ; Hydraulic Maintenance — Table Circuit (21) ; Four-color Schematic (22) ; Cross Feed Circuit (23).	
CHAPTER VII	
Grinding Wheels and How to Select Them	24
CHAPTER VIII	
Optional Mechanisms and Additional Equipment	25
Exhaust Attachment (25) ; Exhaust Nozzle (25) ; Power Down Feed Arrangement (25) ; Extra Vertical Capacity Parts (27) ; Vertical Rapid Positioning Arrangement (27) ; Illuminated Dust Guard (27) ; Wet Grinding Attachment (27) ; Castered Base (28) ; 4¾ Inch Index Centers (28) ; High Speed Surface Grinding Attach- ment (29) ; No. 101-5 Adjustable Vise (29) ; No. 202 Adjustable Swivel Vise (30) ; No. 421-4 Flanged Vise (30) ; Over-the-wheel Truing Attachment (30) ; Radius and Angle Wheel Truing Attach- ment (31) ; Continuous Radius and Tangent Wheel Truing Attach- ment (32) ; Magnetic Chucks (32) ; Sine, Perma-Sine and Perma- nent Magnet Sine Plates (32) ; Mist Coolant Arrangement (33) ; Vertical Position Indicator (34).	

CHAPTER I

Installing or Relocating the Machine

In lifting or moving the machine, it is recommended that the rope be rigged as shown in Figs. 1 and 2. Place wooden blocks or protective material between the rope and the machine wherever the rope is liable to damage any part.

If it is convenient, this machine can be lifted with a fork truck. There is a slot cast into the under-side of the machine for this purpose. One fork is inserted in this slot and the other fork on the under-side of the front portion of the machine. However, when using a fork truck to lift this machine, the table bed guard at one end of the machine will have to be removed and the table moved to the opposite side of the machine. The fork will then be inserted from this side of the machine.

The machines are shipped with a brace clamped to the machine. This brace holds the upright in position as a safety measure during shipment. This brace must be removed before the machine is used. However, we recommend this brace be installed on the machine whenever the machine is moved.

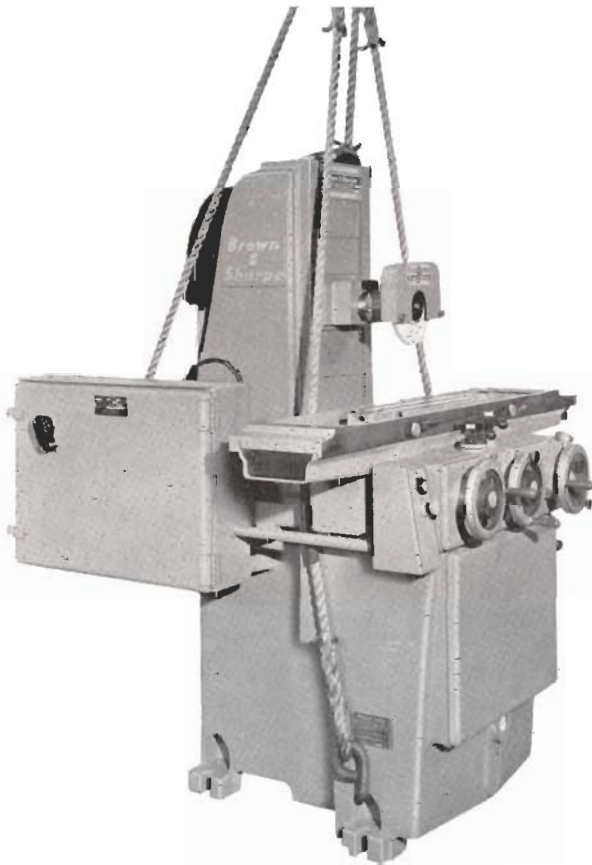

Fig. 1. Proper method of rigging machine.

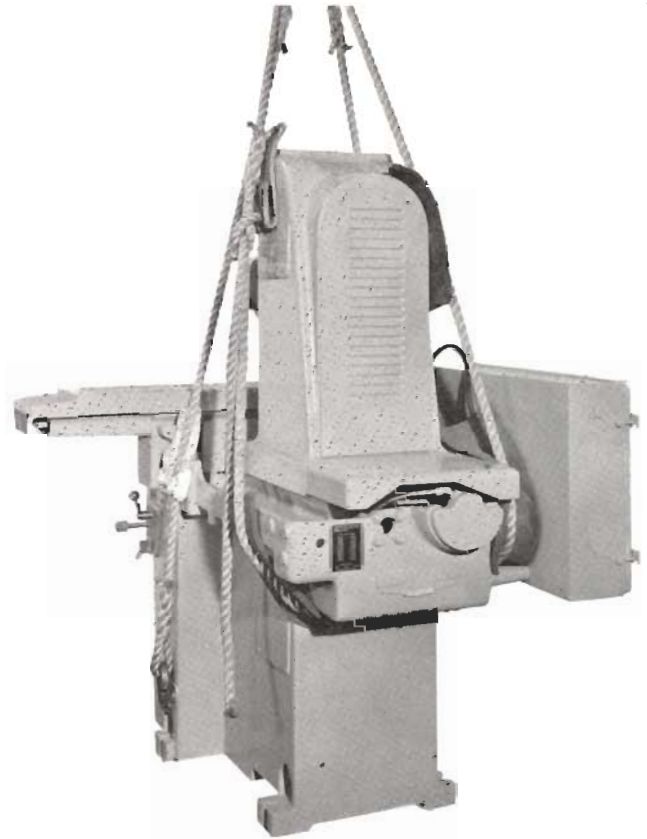

Fig. 2. Rear View of Machine.

The machine should be located on a level foundation or floor, a solid vibrationless foundation being essential where the finest finish must be produced. If the machine must be set on a wooden floor, locate it over a beam and on a portion of the floor which is free of vibration. In case the foundation or floor unavoidably transmits vibration to the machine, set the machine on isolation mounts.

With the machine in position, test the surface of the table both longitudinally and transversely with a precision spirit level and drive a wooden shingle under any corner or corners that may be low. Make sure that all four corners are supported; then tighten the lag screws, test the level of the table surface again in both directions and readjust if necessary.

The subject of connecting to the power supply is covered on page 19. CAUTION: To avoid damage, be sure to check direction of motor rotation as explained on page 19 before running the machine.

CHAPTER II

Operating Controls and Principal Parts of the 618 Micromaster Surface Grinding Machine

Machine illustrated has power table travel and power cross feed, with elevating handwheel located on front of bed.

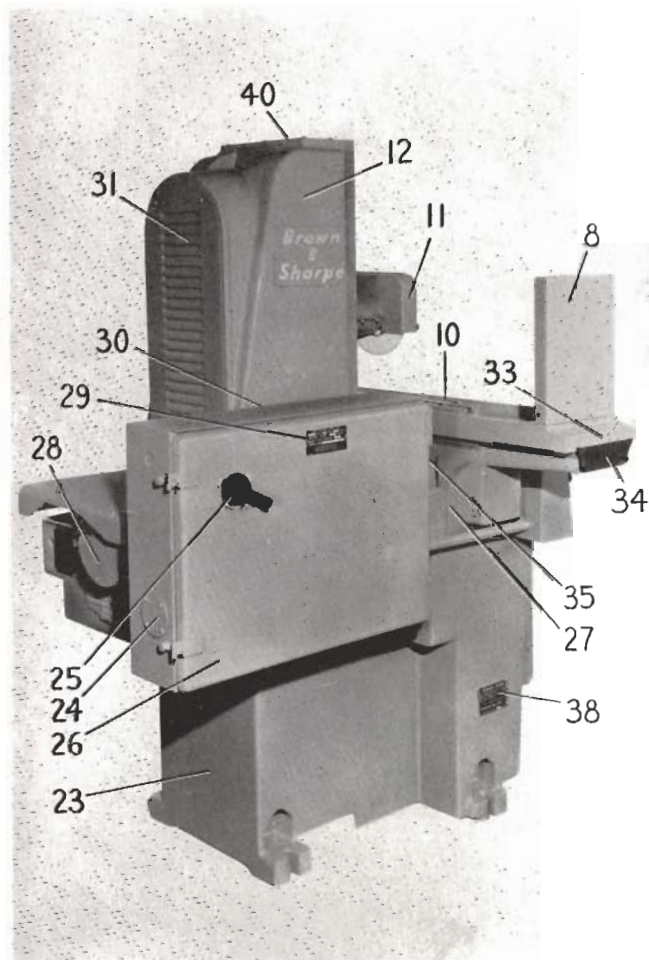
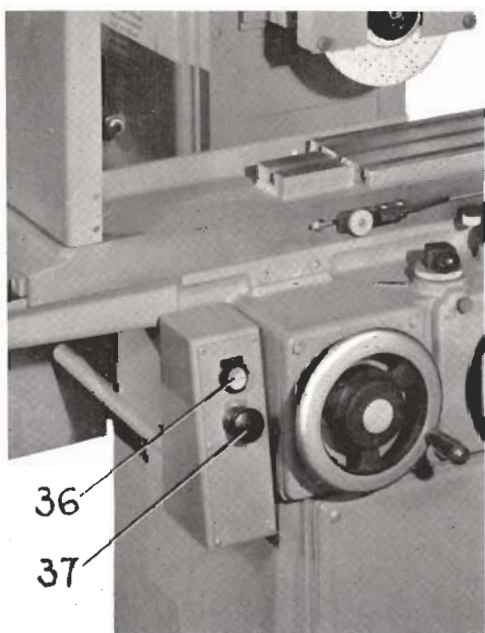
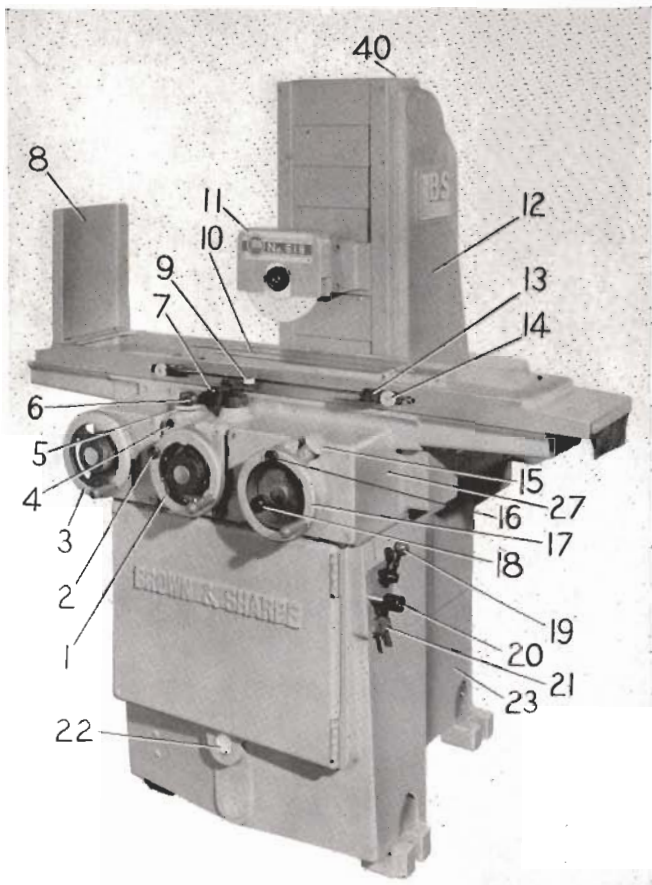

Hand Table Travel and Hand Cross Feed

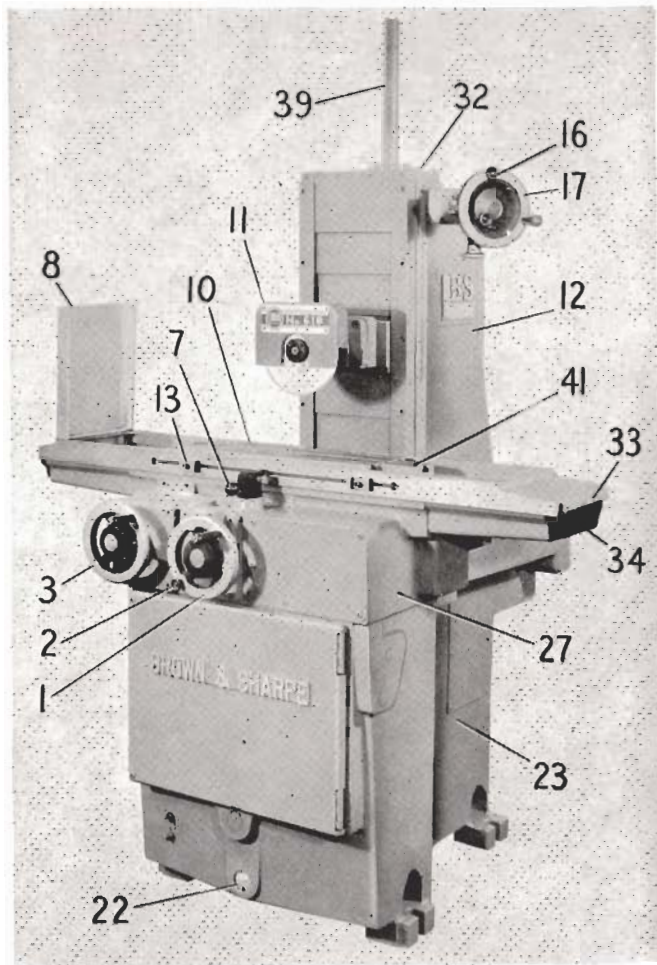

Machine illustrated has hand table travel and hand cross feed, with elevating handwheel located near top of column.

- | | | | |
|----|--|----|--|
| 1 | Cross Feed Handwheel | 22 | Oil Level Sight Glass |
| 2 | Dial Locknut, Cross Feed Handwheel | 23 | Base |
| 3 | Table Handwheel | 24 | Receptacle Box Plate |
| 4 | Set Screw, Throttle Adjustment Bushing | 25 | Disconnect Switch |
| 5 | Throttle Adjustment Bushing | 26 | Electric Compartment Door |
| 6 | Table Throttle Lever | 27 | Bed |
| 7 | Table Reversing Lever | 28 | Cross Feed Cylinder Mounting Plate |
| 8 | Dust Deflector | 29 | Power Specification Name Plate |
| 9 | Reversing Lever Contact Roller | 30 | Wheel Motor Cable (behind compartment) |
| 10 | Table | 31 | Upright Cover, Rear |
| 11 | Wheel Guard | 32 | Elevating Screw Guard Flange |
| 12 | Upright | 33 | End Guard Strap |
| 13 | Table Dog | 34 | End Guard |
| 14 | Carrier Locknut | 35 | Table Bed Guard, Rear (not shown) |
| 15 | Fine Feed Adjustment Knob | 36 | Stop Button |
| 16 | Dial Locknut, Elevating Handwheel | 37 | Stop Button |
| 17 | Elevating Handwheel | 38 | Instruction Plate, Lubrication System |
| 18 | Fine Feed Locknut | 39 | Elevating Screw Guard |
| 19 | Cross Feed Directional Lever | 40 | Elevating Screw Guard, Upper |
| 20 | Cross Feed Regulating Screw | 41 | Serial Number* |
| 21 | Wheel Truing and Rapid Positioning Lever | | |

*Serial number can also be found on the upper part of the base at the rear of the machine.

CHAPTER III

Set-up Adjustments

This chapter explains the purpose and use of each of the controls and adjustments used in setting up and operating the 618 Micromaster Surface Grinding Machine. Although the machine is equipped with Power Table Travel and Power Cross Feed, much of the following information also applies when the machine is equipped with Power Table Travel and Hand Cross Feed or Hand Table Travel and Hand Cross Feed.

Starting the Machine. The push-button located on the left side of machine starts and stops the motors for the spindle drive and the hydraulic pump. In starting the machine, follow instructions below under the heading, "Starting the Spindle".

Vertical Adjustment. The elevating handwheel comes installed on the front of the machine at the

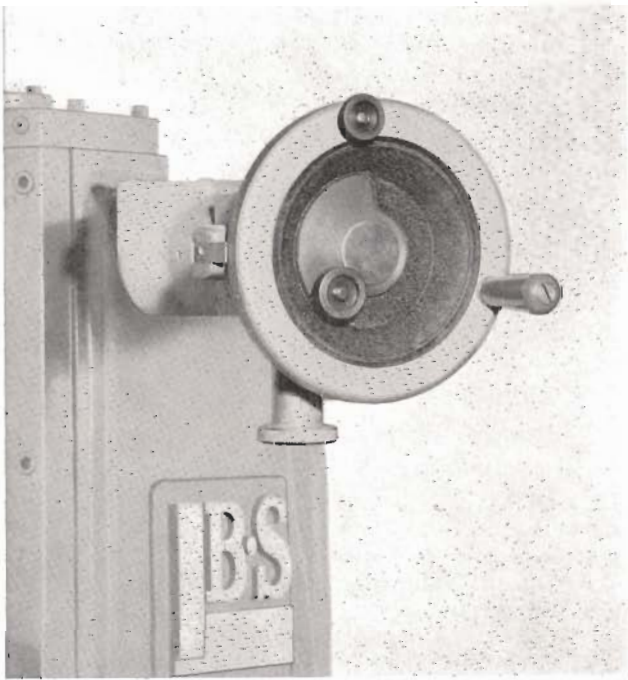

Fig. 3. Elevating Handwheel on the Upright.

right or, if desired, near the top of the upright on the right side. The handwheel has an adjustable dial graduated to read to 0.000,2". A fine feed knob mounted adjacent to the handwheel is graduated to indicate vertical adjustment to 0.000,1".

One revolution of the handwheel moves the grinding wheel 0.05". With the handwheel on the front of the machine, the vertical adjustment is 14 $\frac{3}{4}$ " and the height of the work ground with an 8" diameter wheel is 14". If a 7" diameter wheel is used the height of work ground is 14 $\frac{1}{2}$ ".

When the handwheel is located on the upright, the vertical adjustment is 12 $\frac{3}{4}$ " and the height of

the work ground with an 8" diameter wheel is 12". If a 7" diameter wheel is used the height of work ground is 12 $\frac{1}{2}$ ".

For machines after beginning serial number 523-618-227, add one inch to all vertical capacities.

See Chapter VIII for Extra Vertical Capacity Parts where increased vertical adjustment is desired.

Wheel Spindle

Starting the Spindle. The antifriction-bearing spindle can be started immediately at any time.

When starting a plain-bearing spindle for the first time, or after a few days' idleness, press the START button and almost immediately push the STOP button. Do this three or four times so that the bearings will be adequately lubricated before running the spindle at operating speed.

Instructions on oiling the plain-bearing spindle are given on a plate on the upright, and should be carefully followed in operating the machine.



Fig. 4. Antifriction-Bearing Spindle with Oriflex Drive.

End Play Take-up. In the antifriction-bearing spindle, end thrust in both directions is taken by two opposed preloaded ball thrust bearings.

End play in the plain-bearing spindle is taken up by compression springs which act against a thrust collar in the spindle assembly. (A section drawing of the spindle is shown on page 17.) To take up end play, release and then tighten the clamp screw. CAUTION: The clamp screw should be tightened only while the spindle is running, and only after it has reached its maximum temperature (1 $\frac{1}{2}$ hour of running).

Since the clamp screw merely holds the thrust collar in position and does not govern the closeness of adjustment, there is no reason to use excessive clamping pressure.

For normal surface grinding or when grinding shoulders with the outer face of the wheel, the clamp screw can be released, leaving the thrust springs to take up end play automatically.

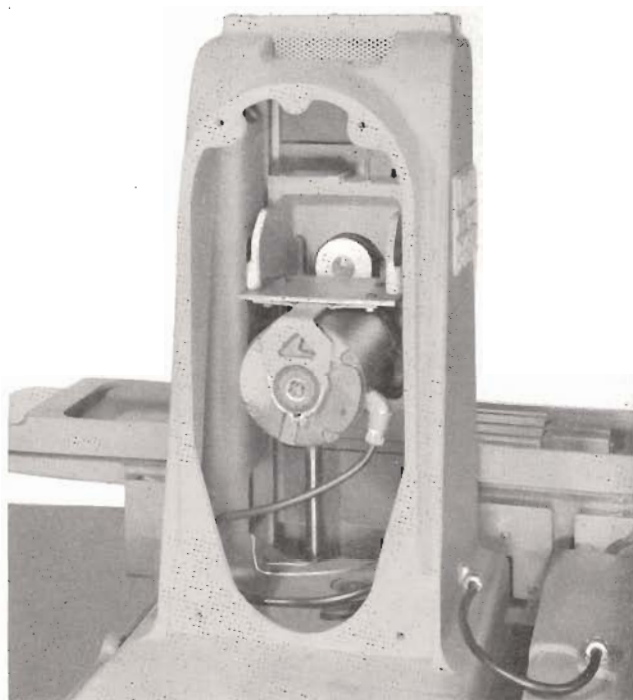

Fig. 5. Rear View of Upright Compartment Showing Motor With Oriflex Drive.

Wheel Speed. When the Spindle is driven by a 60 cycle direct drive motor, the full load speed is 3450 R.P.M. using a 7" diameter wheel, $\frac{1}{2}$ " thick.

With the spindle using the Oriflex drive, the full load speed is 2860 R.P.M. using an 8" diameter wheel, $\frac{1}{2}$ " thick.

Wheel Guard. The wheel guard is a one-piece unit with a hinged cover on the front. The hinged cover opens upward and is held closed by two knurled-head screws. All that is required to remove the wheel is to lift the hinged cover.

However, it is necessary to remove the wheel to remove the wheel guard.

Two clamp screws located on the clamping edge of the wheel guard support can be loosened and the guard tipped either side of horizontal if necessary.

Always make sure that the guard is securely clamped before starting the machine. Never run a wheel without having the guard and its cover in place.

Care and Use of Grinding Wheels

Selecting the Wheel. In order to produce the desired quality of work in the shortest time, real care is necessary in choosing the wheel which is best for the job at hand. The items to consider in making this choice are discussed in Chapter VII (page 24).

Mounting Wheels. One general-purpose grinding wheel and one wheel sleeve are furnished with

the machine. When additional wheels are used, extra wheel sleeves should be procured so that each wheel can be kept on its own sleeve. Thus, in changing from one type of wheel to another, the wheel and sleeve can be changed as a unit and will remain concentric, requiring only a minimum amount of truing.

The wheel should fit easily on the wheel sleeve, yet not loosely. If it is loose it cannot be centered accurately and will consequently be out of balance. Do not wrap the sleeve with paper etc. to make a wheel fit when the hole is too large. It is better from all standpoints either to discard such a wheel or recast the core.

A wheel that fits a trifle tightly may crack if forced on the sleeve. If the hole is only a little under size it can easily be scraped out to fit.

Before mounting a wheel, hang it in the air on one finger; then lightly tap the edge of the wheel and see if it gives a clear ringing sound. A wheel that does not ring clear is probably cracked and should not be used.

The inner of the two flanges between which the wheel is mounted is a part of the wheel sleeve (see Fig. 6). The outer flange consists of a steel disk or washer which is keyed to the wheel sleeve to keep it from turning and loosening the clamping nut.

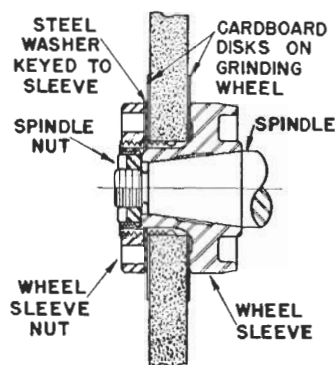

Fig. 6. Proper mounting of grinding wheel.

To equalize the clamping pressure, washers of cardboard or rubber should be placed between the wheel and the two flanges. Most wheels of the size used on this machine have a ring of heavy blotting paper on each side, which serves the purpose.

Using the pin wrench furnished, tighten the clamping nut enough to hold the wheel firmly in place on the sleeve. Do not tighten too much, however, as excessive clamping pressure will crack the wheel.

Changing Wheels. In removing a wheel sleeve from the spindle, always use the wheel sleeve puller (furnished with the machine) to avoid any chance of cracking the wheel or damaging the spindle bearings by pounding. Remove the spindle nut (this nut has a *left-hand* thread); then thread the

outer member of the wheel sleeve puller into the wheel sleeve and tighten the inner screw against the spindle, thus loosening the wheel sleeve without harmful jarring.

In putting a wheel on the spindle, first see that both the wheel sleeve hole and the spindle end are perfectly clean. Then slip the sleeve onto the spindle, seat it by hand and tighten by means of the clamping nut and wrench.

Balance of Wheel. It is essential that the wheel run perfectly true and without vibration. Grinding wheels are balanced by the manufacturer and, in the case of wheels of the size used on this machine, should not require attention in this respect other than truing. A wheel that runs badly out of balance after truing should be discarded or returned to the wheel manufacturer—though in cases of necessity the condition may be corrected by digging out part of the wheel beneath the flange and filling with lead as indicated by a test for static balance.

Wheel Truing. A wheel truing fixture is furnished with the machine. The truing diamond (not furnished) may be applied to the wheel along any line on the lower half of the wheel circumference, though preferably at the bottom of the wheel as shown in Fig. 7. To prevent gouging, the center line of the diamond tool should point slightly beyond the center of the wheel in the direction of movement of the wheel surface.

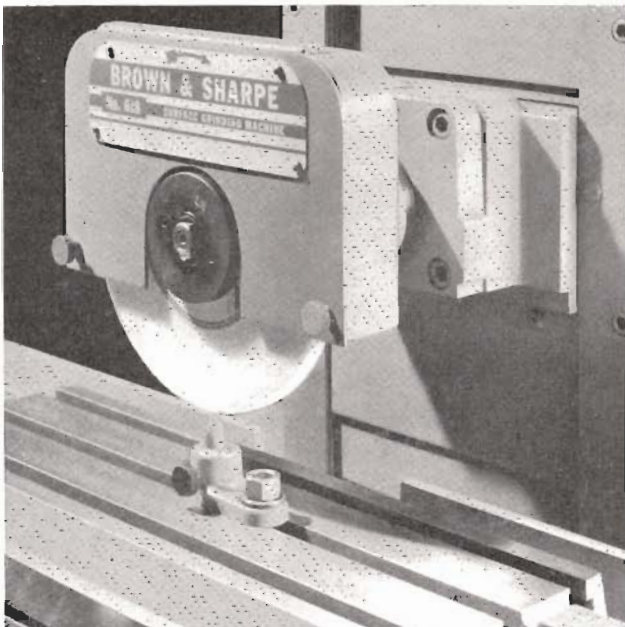

Fig. 7. Wheel truing fixture in use.

The wheel should be trued each time it is put on the spindle and whenever it becomes loaded, dull or glazed. Pass the diamond across the wheel with

a slow, steady manual cross feed, taking care to avoid any longitudinal movement of the table.

In truing a wheel for rough grinding, take a cut about 0.000,5" deep in one pass of the diamond across the wheel and finish with a similar cut 0.000,25" deep. If the wheel is to be used for finish grinding, take two 0.000,5" cuts; then take two or three additional cuts removing about 0.000,25" each time, and finally pass the diamond across the wheel once or twice without further advance of the wheel. The figures stated are approximate and under some conditions should be varied somewhat to give desired results.

The wheel can be trued to a radius or angle and combinations of radial and angular shapes can be obtained by using the Radius and Angle Wheel Truing Attachment described on page 31.

Accurate radii, both concave and convex, with accurate tangents at either or both sides of the radii can be formed with the Continuous Radius and Tangent Wheel Truing Attachment described on page 32.

Longitudinal Table Travel

Power Travel. To engage the power table travel, turn the Table Throttle Lever (Fig. 8) clockwise until the desired table speed is attained. Loosen the bushing set screw and turn the Throttle Adjustment Bushing until the pin rests against the lever; then tighten the set screw. The machine is now set at a table speed which will not require resetting if the machine is stopped.

The Table Throttle Lever not only adjusts the power table speed, it also provides a convenient means of starting and stopping the table travel.

Power table travel is obtained through a hydraulic piston at a speed of from 5 to 100 feet per minute.

The handwheel automatically disengages when using power table travel.

Maximum longitudinal table travel is 22".

Table Reversal. For power operation, table reversal is controlled either manually or automatically. The Reverse Lever is shown in Fig. 8.

In setting the table dogs for automatic reversal, be sure to allow enough over-travel. The work must go beyond the grinding wheel in both directions to assure the completion of cross feeding before the work comes back under the wheel.

Hand Table Travel. The table handwheel is located on the front of the machine and to the left (Fig. 8). Hand table travel is driven through a cog belt rather than the conventional rack and

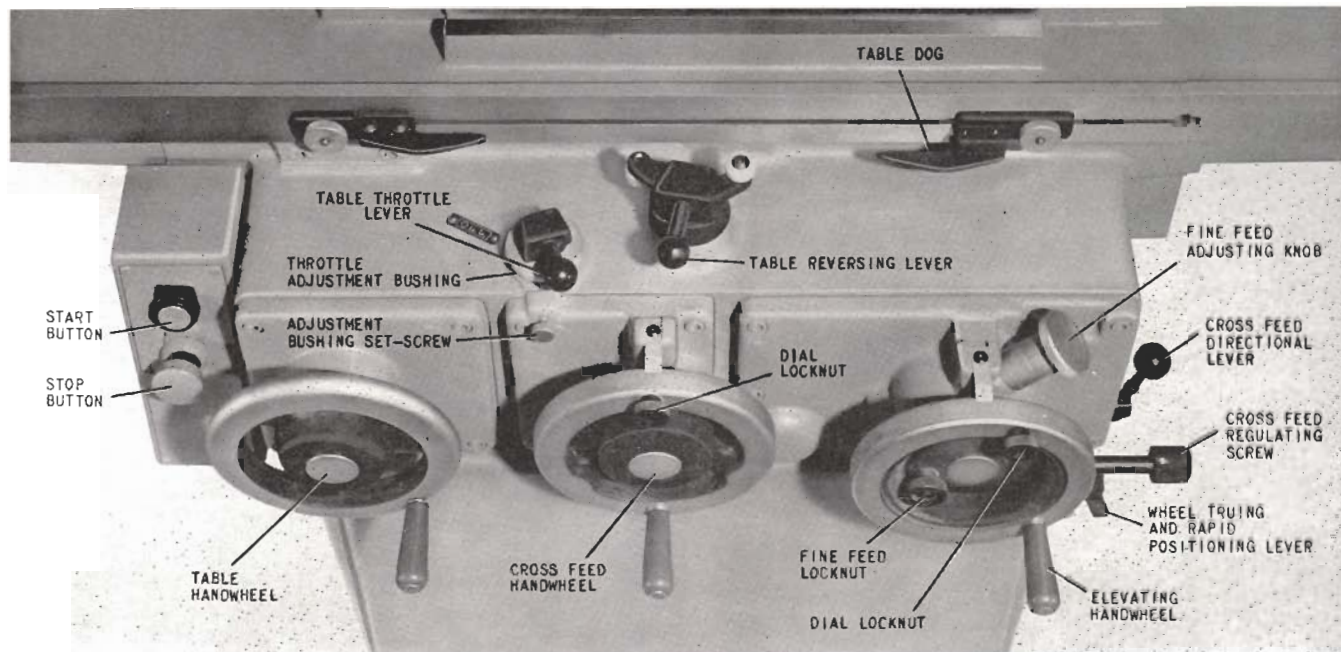

Fig. 8. Front Controls.

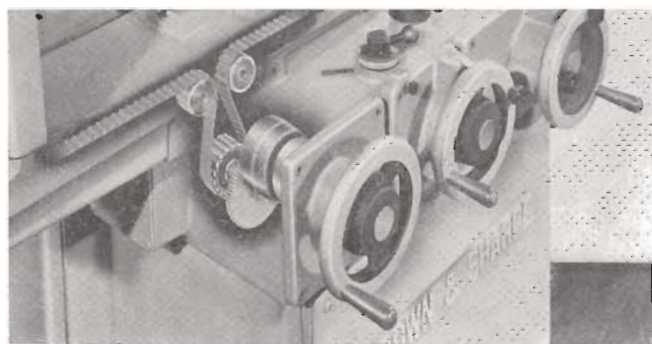

Fig. 9. This set-up provides for smooth operation of the table.

pinion gears. One turn of the handwheel moves the table $2\frac{1}{2}$ " (see Fig. 9).

Although the handwheel is always engaged for manual operation, it disengages automatically when using power table travel.

Drive. The machine is equipped with a 1 HP motor for driving the wheel spindle. An Antifriction Bearing Spindle is furnished with Oriflex Drive (Fig. 4) which transmits the full power of the motor to the spindle through 5 "O" rings at a speed of 2860 R.P.M.

If preferred the Antifriction Bearing Spindle can be furnished with Direct Motor Drive with a spindle speed (full load) of 3450 R.P.M.

If desired a Plain Bearing Spindle is available (at extra cost) with a speed of 2860 R.P.M. and equipped with Oriflex Drive.

The illustration (Fig. 4) shows the motor with Oriflex Drive located in the upright compartment.

Cross Feed

Power Cross Feed. The cross feed handwheel is located centrally on the front of the machine (Fig. 8). It has an adjustable dial graduated to read to 0.000,2". A handwheel (at extra cost) is available which has a separate adjustable dial graduated to read to 0.000,1".

Any cross feed from 0.01" to 0.25" can be obtained at each reversal of the power longitudinal table travel. The maximum travel is 7". A continuous hydraulic cross feed of 10 inches per minute is provided for wheel truing and a fast positioning of the wheel at 12 feet per minute.

To start the intermittent cross feed, turn the selector lever to the grind position. Next, turn the cross feed directional lever for forward or reverse direction of wheel slide upright. Start the table with the table throttle lever and adjust the amount of cross feed desired with the cross feed regulating screw.

To obtain wheel truing speed, turn the wheel truing and rapid positioning lever to true position. The cross feed can be started by turning the table throttle lever clockwise. The cross slide direction is selected by the cross feed directional lever.

For power positioning of the wheel slide upright, turn the wheel truing and rapid positioning lever to rapid position. Turn the table throttle lever clockwise and select the cross slide direction with the cross feed directional lever.

Table Dogs. It is advisable to check the table dogs (Fig. 8) before running the power table

travel to prevent any mishap. The dogs can be set to limit table travel in either direction.

Use the handwheel to bring the work to the desired points of reversal. Loosen the carrier locknuts so that the table dogs can be moved along the front of the table. Move the table to the left and locate the desired point of reversal. Next, move the right table dog so that it contacts the right reversing lever contact roller. Then set the right table dog by tightening the carrier locknut.

Locate the position of the left table dog in the same way, moving the table to the right to locate the desired point of reversal. Next, move the left table dog so that it contacts the left reversing lever contact roller. Then set the left table dog by tightening the carrier locknut.

Suggestions on Set-Up and Operation

Clamping Work to Table. In clamping workpieces, chucks, vises etc. to the table of the machine, use only enough clamping pressure to hold the part from slipping. Tight clamping is not necessary, since the forces exerted on the work are quite small. Excessive clamping might spring the table enough to cause inaccuracies in the work.

Rough and Finish Grinding. In general, it is not advisable to use one machine consistently for heavy hogging cuts and for highest-quality finish grinding as well. If large amounts of heavy roughing

work are to be done, it is best to use one machine for that class of work and do the finish grinding on a machine reserved for finish grinding only.

Form Grinding. Under proper conditions of maintenance and by using adequate care in operation, highly accurate form grinding can be performed on these machines.

Spindle Alignment. The contacting surfaces of the spindle head and spindle sleeve flange are ground at our factory to give a good commercial accuracy of alignment of the spindle with relation to the table ways. For shoulder grinding jobs which demand greater-than-ordinary closeness of parallelism between the side of the wheel and the table travel, the required alignment can be secured by carefully scraping the spindle sleeve flange. Note that any alteration by scraping should be done on the flange and not on the face of the spindle head. The spindle head should remain untouched so as to permit other spindles to be used in the machine.

Dry Grinding. In dry grinding operations use an exhauster to protect the operator, the machine itself and neighboring machines from the grit and dust produced. Either connect the machine to a central exhaust system or use an exhaust attachment such as the one described on page 25.

CHAPTER IV

Typical Operations

The operations shown in this chapter are representative of the various types of work performed on these machines. While no attempt has been made to describe each job in detail, the main features of set-up and operation are outlined as a guide to good grinding practice.

Operations shown utilize available additional equipment as well as equipment furnished with the machine. Operations within the capacity of the 618 Micromaster can be performed with ease and efficiency.

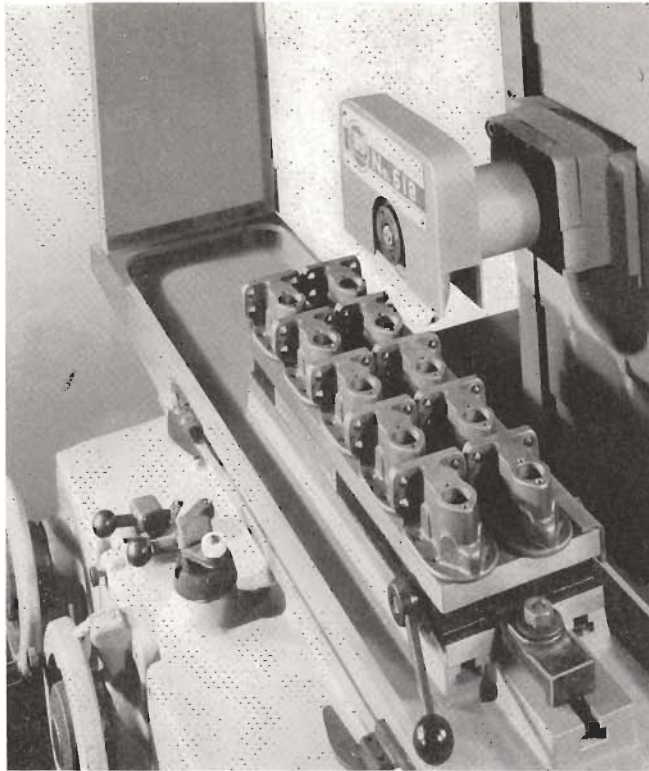

Fig. 10. A representative production job grinding the surface of ten pieces with one loading of the permanent-magnet chuck.

Fig. 11. That the table sets in fixed ways contributes immeasurably to slot and other forms of side wheel grinding.

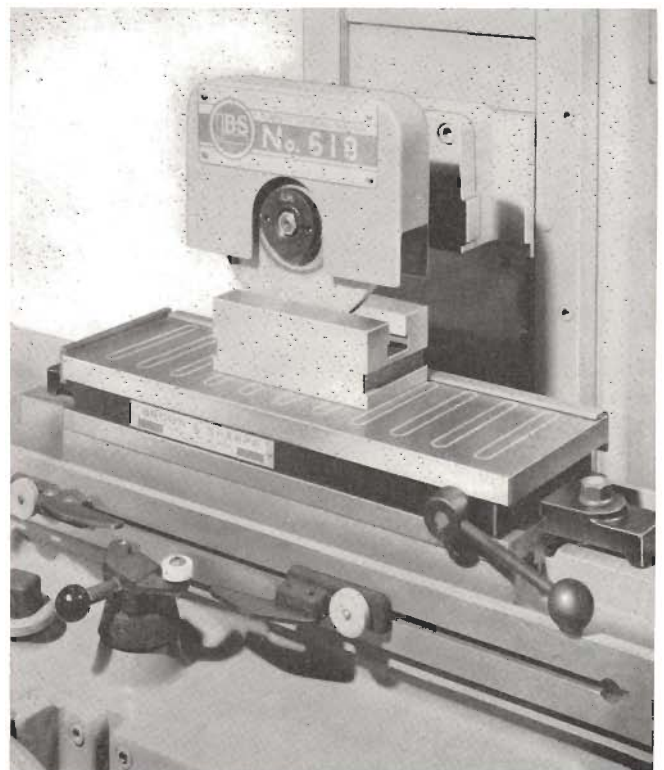

Fig. 12. Picture at right illustrates the vertical capacity of the machine.

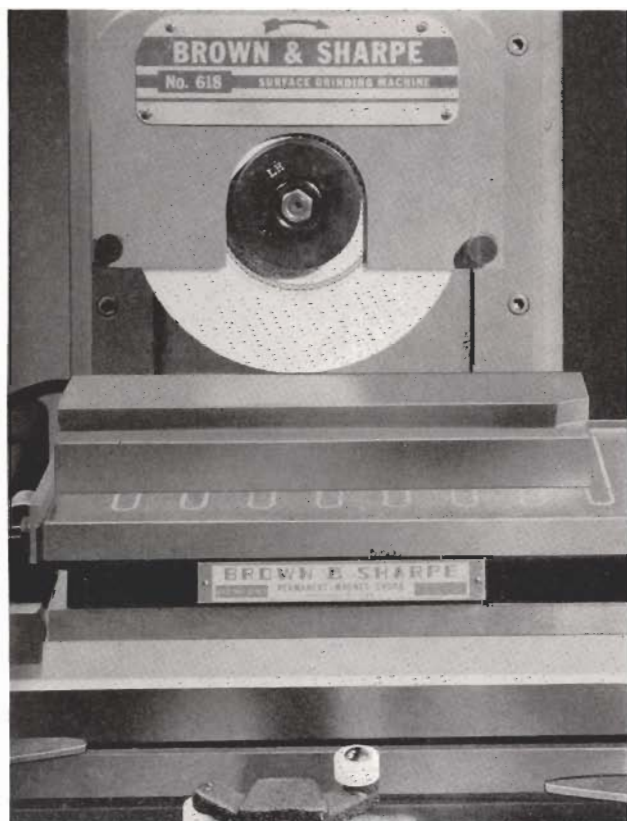
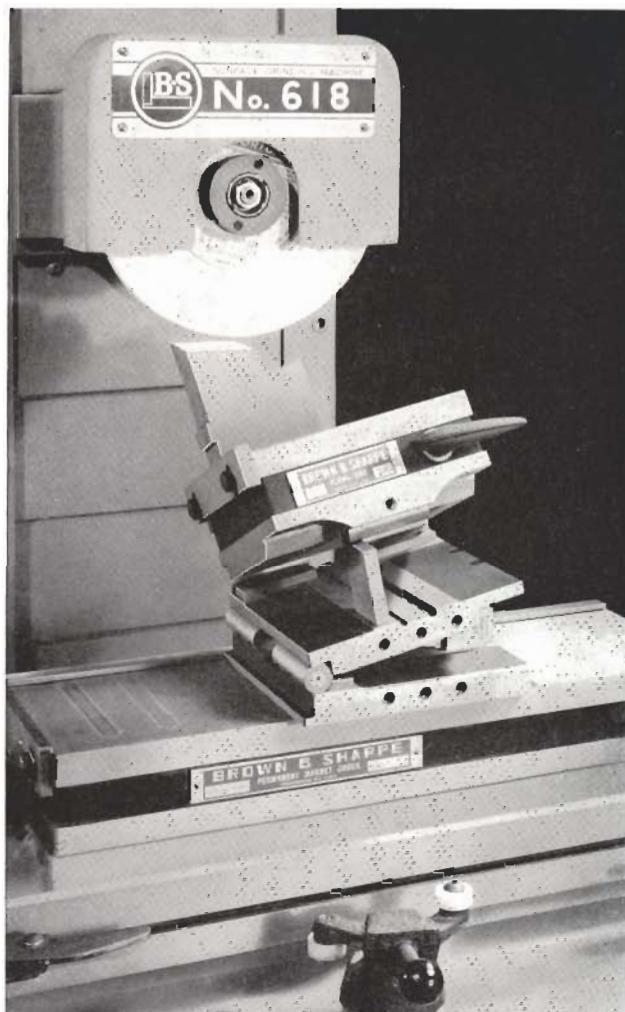

Fig. 13. Another typical operation in which slot and side wheel grinding are featured.

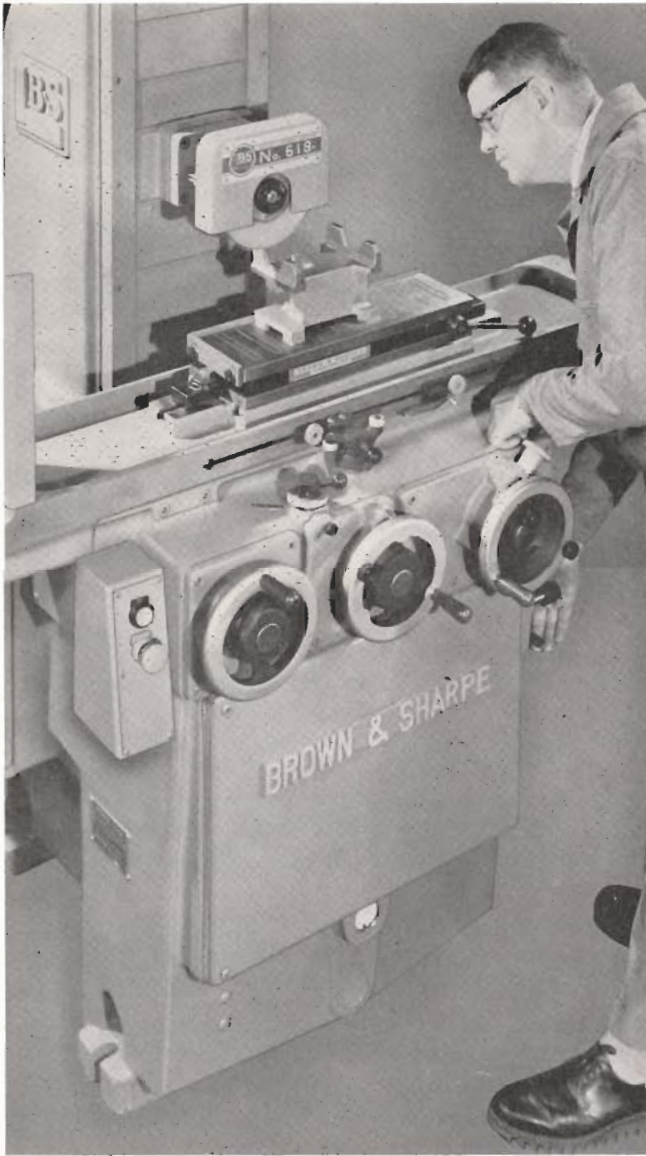

Fig. 14. Finishing four legs of a drill jig to uniform height.

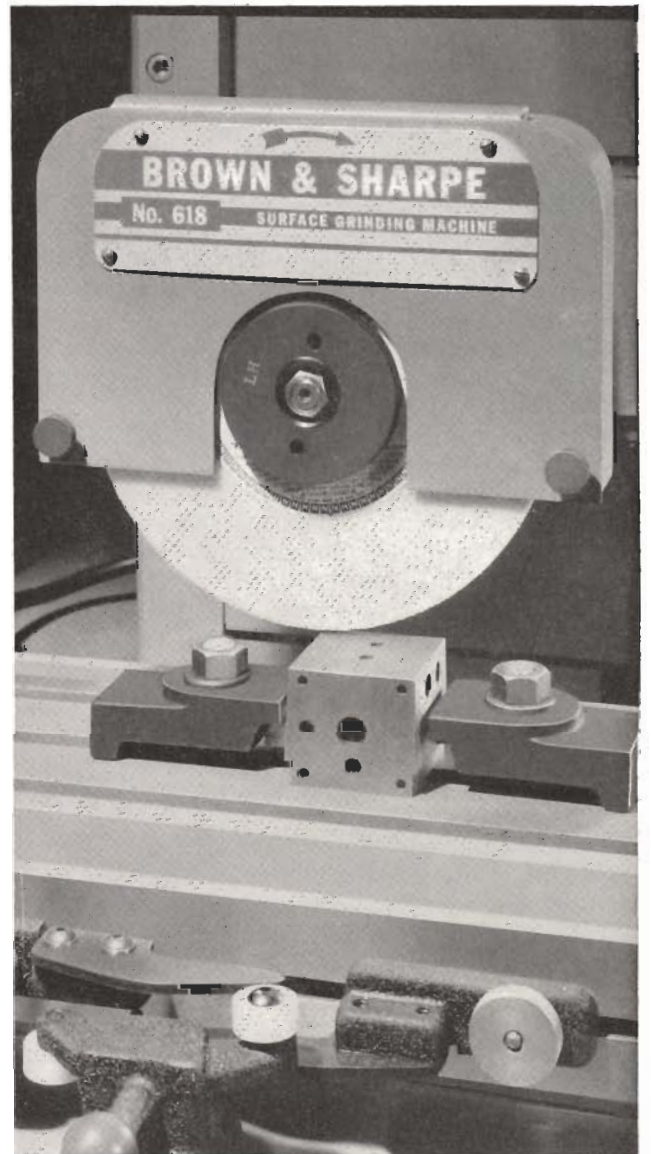

Fig. 15. Typical operation showing work piece clamped to the table.

CHAPTER V

Maintenance**Lubrication**

With machines having power table travel or both power table travel and power cross feed, lubrication is obtained by tapping off the hydraulic panel. Tank capacity is approximately 15 gallons. A good grade, high lubricity hydraulic and way oil having a viscosity of 150 S.S.U. at 100° F. is recommended. It is further recommended that the oil and the filter be changed annually.

With machines having hand feed only, a lubrication pump is operated by the movement of the table. Here too, a good grade, high lubricity table way oil is recommended. This oil should have a viscosity of 300 S.S.U. at 100° F. The tank capacity is approximately 5 gallons. Oil and filter should be replaced annually.

Wheel Spindle

Wheel Spindle. Machine is equipped with a super-precision antifriction-bearing unit with a choice of either Oriflex drive (through 6 "O" rings) or direct motor drive. Either drive is from a 1 H.P. motor. They are removable unit-type construction and are interchangeable.

The wheel sleeve furnished takes wheels up to 1/2" thick and an available sleeve (at extra cost) takes wheels up to 1" thick.

A plain-bearing spindle unit is available at extra cost (with Oriflex drive only).

A grinding machine spindle may be properly classified as a high-precision tool. The accuracy of construction required will be realized from the fact that a variation of one hundred-thousandth of an inch (0.000,01") in a ground flat surface will be visible to the naked eye as a wheel mark. Consequently, the best results can be obtained only if the spindle is treated with the consideration due to any fine precision instrument. *Hammering on the ends of the spindle, dropping it on the floor or work bench, or any other undue application of force or impact must be carefully avoided* if the spindle is to be kept in proper running condition.

If eventually a spindle should need repair or adjustment, we recommend that it be returned to our factory for reconditioning. By installing an extra spindle unit, kept on hand for such contingencies, production can continue with little interruption. It is a quick and simple matter to change spindles on these machines. If necessary, detailed instructions for the plain-bearing spindle on the following page will frequently permit the required work to be done successfully in the customer's shop by a careful workman having adequate skill and equipment.

Removing Spindle Unit from Machine

Open the wheel guard cover, remove the wheel, and then the wheel guard. Then take out the four clamping screws in the spindle unit flange.

If equipped with Oriflex drive remove the guard at the rear of the upright and lift the six "O" rings away from the spindle pulley. Remove pulley set screw locking screw, and back-off set screw (located in one of the grooves). Take pulley off spindle. Draw out the spindle unit from the front of the machine.

For direct drive follow the instructions in the first paragraph and loosen the knurled spindle head screw. Remove the guard at the rear of the upright, disconnect motor cable and draw out the spindle unit from the rear of the machine.

Antifriction-Bearing Spindle Unit

This spindle unit has the spindle mounted on super-precision, preloaded ball bearings at both front and rear. Grease lubrication is used and the spindle's cool running temperature is quickly reached. The unit is sealed and requires no additional lubrication after it leaves our factory. As dirt cannot enter past the seal this spindle has a long trouble-free life.

Lubrication. All the spindle bearings are packed with a special grease at the factory and the unit requires no further lubrication.

Maintenance. Because of the extreme care required in disassembling and reassembling this spindle, we strongly recommend that any antifriction-bearing spindle unit which needs repair be returned to our factory for reconditioning.

Plain-Bearing Spindle Unit

The spindle in this unit has small clearance in its boxes, which practically eliminates radial play and cuts spark-out time to a minimum. The light spindle oil used results in low running temperature, quickly reached after starting. (Provision is made for quickly removing end-play without removing the spindle unit, through spring take-up controlled by a screw clamp which serves as a positive lock.)

Lubrication. Automatic lubrication is provided by a rotating pump unit integral with the spindle. A constant level oiler (Fig. 16) supplies oil to a reservoir in the spindle unit.

To fill the spindle reservoir, tilt the constant-level oiler bottle down and fill it through the spout. then tip it back into working position. When the reservoir is empty, fill the bottle twice to bring the oil to the required level. Never start a spindle without oil showing in the oiler bottle.

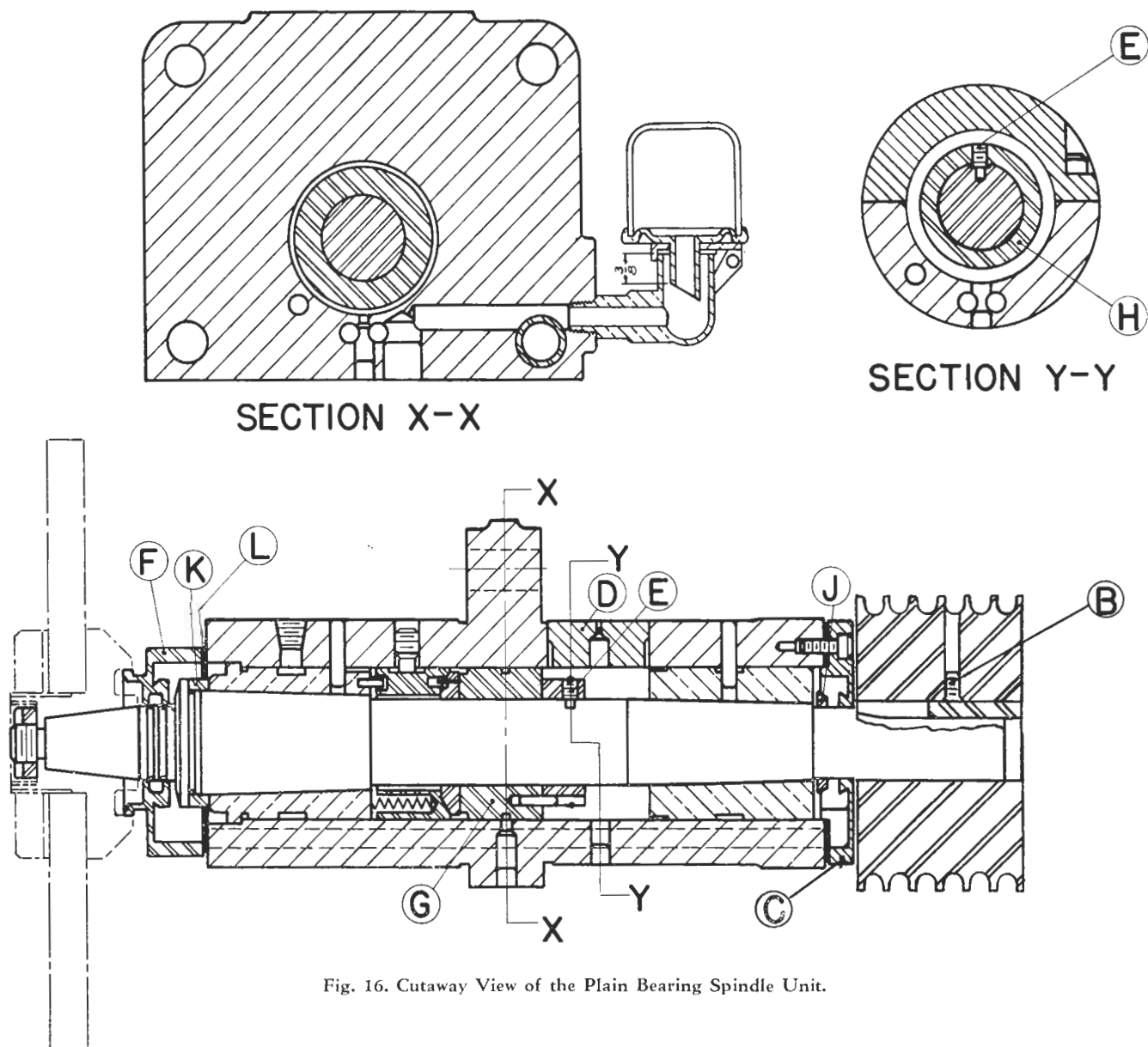

Fig. 16. Cutaway View of the Plain Bearing Spindle Unit.

Take particular care to keep the oil clean. Use a clean oil can, and always wipe the oiler bottle and adjacent parts before tilting the bottle for filling. Preventing grit and dust from reaching the oil space will increase the life of the spindle bearings materially.

Correct Height of Oiler. To assure proper height of oil in the spindle reservoir, the vertical distance from the shorter side of the diagonally-cut spout to the top edge of the cup (with bottle swung down) must be $\frac{3}{8}$ " (see Fig. 16).

Disassembling and Repairing the Plain-Bearing Spindle Unit

Removing the Spindle. Remove the spindle unit from the machine as described on page 16, grip

it securely in a horizontal position between the soft (leather or brass) jaws of a vise, and proceed as follows:

1. Take out the screw B (Fig. 16) that holds the driving pulley on the spindle.
2. Remove the spindle dust guard C (Fig. 16).
3. Take off the spindle bearing sleeve cover D and remove teated screw E.
4. Remove the screws in the dust guard F; then pull off the spindle dust guard F unless the dowels are so tight as to make this difficult.
5. Tap the rear end of the spindle to free the thrust collar G, oil slinger J and (if necessary) spindle dust guard F. Use a soft hammer for this,

and be careful not to use any more force than is necessary.

6. Pull out the spindle and place the loose parts on a clean cloth or sheet of paper.

Checking Oil Space in Boxes. The taper in the front and rear boxes is a continuous one — that is, the two boxes are like one long taper box with a section cut away in the middle. The thickness of the oil space is governed by the thickness of the spindle front box thrust washer K and should be 0.000,7".

With the spindle boxes properly scraped, the correct thickness of washer K is determined as follows:

1. Leave the spindle sleeve clamped horizontally in the vise, strap it to a plate or otherwise secure it against endwise movement.

2. Insert the spindle with washer K in place but leaving off all other parts. (It makes no difference if the washer is too thick for a fit.)

3. Fasten a dial indicator so it cannot move with relation to the spindle unit and set the point of the indicator on the rear end of the spindle.

4. Push the spindle in so that washer K is well seated and set the indicator to read zero.

5. Remove the spindle, take off washer K and put the spindle back in the sleeve. Push the spindle into the boxes with a force of approximately 6 lbs. to get metal-to-metal contact, and note the indicator reading. Be careful to use only enough pressure to bring the spindle in contact with the boxes. Excessive pressure will distort the spindle and boxes, causing a faulty indicator reading and resulting in too small an oil space.

6. To determine the required thickness of washer K, subtract the indicator reading from the measured thickness of the washer and add 0.017". Bring the washer to the required thickness by grinding and lapping, working to the limits of plus 0.000,25", minus 0.000,00".

Repairing a Stuck Spindle. A spindle which has stalled or become stuck in the boxes will project quite noticeably at the front box thrust washer K. This looks like a much more serious condition than it actually is. If the spindle should be held away from the boxes by as little as 0.000,5" on a side, the space at the front washer would be increased by about $\frac{1}{32}$ " due to the small angle of taper of the boxes.

Disassemble the spindle as instructed and examine the bearing surfaces in both boxes. If there are just a few high spots in one of the boxes they can usually be removed by careful scraping, using the spindle as a test plug. Carefully clean the spindle of any adhering foreign matter and make sure that all fine chips or bronze dust are cleaned out of the boxes before testing. In removing the high

spots, continue the scraping until the spindle goes into the boxes with the original washer bearing against the end of the front box. After completing this operation it is advisable, even if only a few spots were scraped, to check the thickness of the oil space as described above.

If the bearing surfaces have become badly scored a thorough rescraping job will be required, again using the spindle as a test plug. Watch the alignment as shown by the bearing on both boxes, and scrape the seized box or boxes so that the spindle will center properly in both boxes as the scraping nears completion. After completing the scraping, clean all parts thoroughly and correct the thickness of the front box thrust washer K to give the proper oil space as described at left.

Reassembling the Plain-Bearing Spindle Unit

First make sure that all parts are perfectly clean and that dirt or dust will not get into the spindle sleeve during reassembly. Then, holding the spindle sleeve between brass or leather vise jaws, proceed as follows:

1. Put the front box thrust washer K on the spindle and insert the spindle in the boxes, slipping the thrust spring retainer (with springs in place), the central thrust washer and the thrust collar H onto the spindle in that order as shown in Fig. 16.

The thrust collar G is made a wringing fit on the spindle, and the hole must *not* be enlarged to make it fit more freely.

2. Fasten the thrust collar G in position. The teated screw E engages one of three radial holes spaced 120° apart around the spindle and at different distances from the spindle end. When the front box thrust washer K is at full normal thickness ($\frac{3}{16}$ " or more), locate thrust collar G so screw E will engage the hole nearest the rear end of the spindle. When washer K is between $\frac{3}{16}$ " and $\frac{1}{8}$ " thick, put screw E in the middle hole; when washer K is $\frac{1}{8}$ " thick or less, put screw E in hole nearest the front of the spindle. This maintains proper pressure of the thrust springs as the spindle is brought inward.

3. Replace the spindle bearing sleeve cover D. Since this cover must be oil tight, lightly coat the horizontal clamping surfaces and fill grooves in the sides of the cover D with a sealing compound. To help keep the sealing compound out of the spindle unit, take care not to coat the side surfaces of the cover other than to fill the grooves.

4. Replace the spindle dust guard F.

After the front box thrust washer K has been reduced in thickness about $\frac{1}{16}$ " in connection with rescraping the spindle, the spindle dust guard F (which does not drop back with the spindle) may begin to interfere with the wheel sleeves. To pre-

vent this, remove about $\frac{1}{16}$ " from rear surface L of the dust guard into proper relation with the grooves in the spindle. In doing this, be careful to keep surface L square with the sides of the dust guard. Fasten the dust guard in place and check with a feeler gage to see that there is clearance all around between the spindle and dust guard. If the guard touches the spindle, scrape it at that point just enough to clear the spindle.

5. Replace the oil slinger J locating it within $\frac{3}{32}$ " of the end of the rear box.

6. Replace the spindle dust guard C and the driving pulley or coupling, thus completing the spindle assembly.

Replacing Spindle Unit in Machine.

If the spindle has Oriflex drive, insert the spindle unit through the front of the spindle head and replace the pulley on the rear of the spindle (do not tighten pulley at this time). Clamp the spindle unit flange to the spindle head. Tighten the four screws in rotation using a wrench on a screwdriver to bring the flange up tight. Remove the two screws holding the guards to the lower front of the spindle head, and "drop" the guards. Working through the opening thus exposed, line up the face of the spindle pulley with the face of the motor pulley (a steel scale can be used for this purpose). With the pulley faces lined up (this is important), tighten the set screw in the spindle pulley, and replace the set screw lock screw. Install the six "O" rings in the grooves of both pulleys. Replace the guards at both the front and rear of the upright.

If a direct drive spindle is used, insert spindle unit in the rear of the machine upright. Connect motor cable and replace guard at the rear of upright. Next, tighten the knurled spindle head screw. Do not under any circumstances remove the flange. This flange aligns the spindle and is set at the factory.

It is possible to increase the transverse capacity on the direct-drive spindle by simply moving the unit in or out.

Connecting to Power Supply. The machine should be connected to the power line and properly grounded. The lines from the power source should be connected to the electrical control panel through a hole at the back of the machine provided for this purpose.

Checking Motor Rotation. Before running a newly-connected machine, check the direction of motor rotation as follows:

Press the START button, *immediately* press the

Possible Sources of Grinding Trouble

Work shows wheel marks (chatter finish)

Chatter may be due to poor choice of wheel for the material being ground (see page 24).

The grinding wheel may be out of balance. If so, it should be balanced or replaced (see page 9).

The condition may be due to vibration of the floor or foundation on which the machine is located. If this is the case, the situation may be improved by using isolation mounts between the floor and the machine.

Excessive oil space in a plain-bearing spindle, or loose bearings in an antifriction-bearing spindle, will result in a chatter finish.

If the grinding wheel is not securely clamped to the wheel sleeve, repeated starting and stopping may shift the position of the wheel, resulting in chatter finish.

Spindle runs too hot or stalls

Using the wrong kind of oil will cause this. Use only an extra-light, high-quality spindle oil having a viscosity of 60 Seconds S.U.V. at 100° F. for the plain-bearing spindle.

May be due to insufficient oil. With the plain-bearing spindle, check the vertical position of the constant-level oiler (see page 17).

Plain-bearing spindle leaks oil

This may be due to flooding of the spindle reservoir as a result of improper filling. The correct method of filling the reservoir is described on page 16 under "Lubrication".

Air may be leaking into the oiler bottle, resulting in too high an oil level in the spindle reservoir. In this case it is usually best to replace the oiler.

Table and Cross Feed Mechanisms

These mechanisms seldom require adjustment or replacement, and their relatively simple construction will enable any competent maintenance mechanic to do the necessary work without difficulty.

The illustrations in the Repair Parts booklet will prove helpful in working on all parts of the machine.

Electrical Controls

STOP button and observe the direction of rotation of the wheel spindle. The spindle should rotate clockwise as seen from the front. If the direction of rotation is counterclockwise, reverse one phase of the power supply. (This is conveniently done by transposing two of the wires at the line disconnect switch.) Do not change the internal wiring of the machine. To avoid serious damage to the spindle, do not under any circumstances allow the machine to run with the spindle turning in the wrong direction.

CHAPTER VI

Hydraulic System*

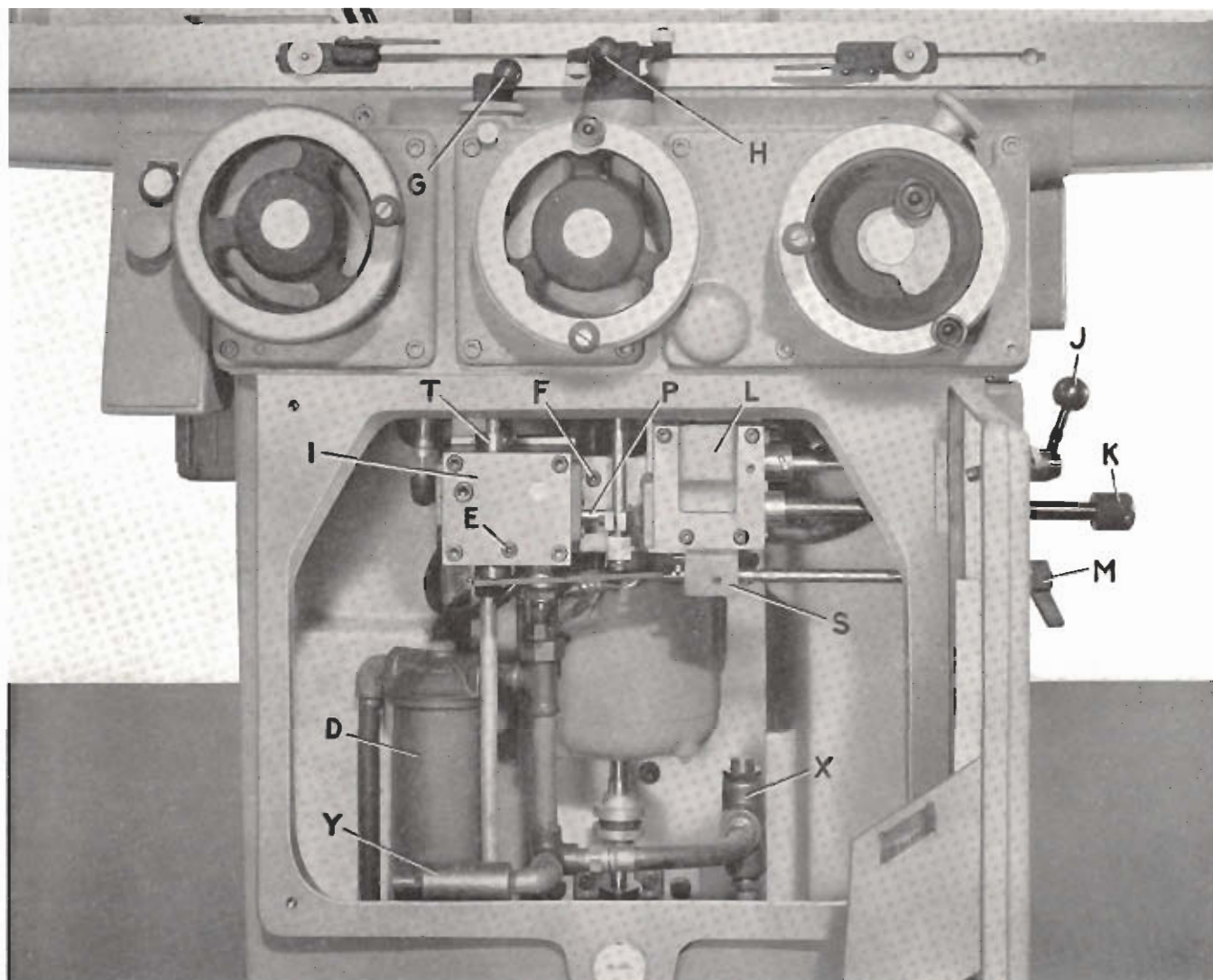

Fig. 17. Front Compartment Reveals Hydraulic System.

The reservoir for the hydraulic system should be filled with approximately 15 gallons of high lubricity hydraulic oil having a viscosity of 150 S.S.U. at 100°F. The by-pass filter cartridge (D) and the oil should be renewed annually and the base compartments thoroughly cleaned to remove any foreign substance which may have entered the system. When first starting a new machine or after changing the oil, run the pump for about an hour with the table speed control in the off position. This will allow any contamination in the new oil to be filtered out and settled at the bottom of the reservoir. If the machine is not run for a long period of time, gum deposits may form in the valves causing the pistons to stick. If this happens, use one of the

solvents available from the several oil companies to flush out the system.

Cleaning Hydraulic Reservoir. The oil can be removed from the reservoir by connecting a flexible line from the pump discharge to a barrel outside the machine. It will then be necessary to remove the drain plugs for the oil remaining at the very bottom. When the reservoir is empty, wipe with a lint-free rag saturated with solvent.

Adjustment of Pressure Relief Valves. There are two pressure relief valves which are adjusted and locked at our factory. If through some unforeseen circumstance or accident their setting is dis-

*Refer to Figure 17 and the full color schematic diagram on page 22 for identification of parts and check points mentioned in the copy.

turbed, they can easily be reset. The high pressure relief valve (X) is tested by removing the one-quarter inch pipe plug (E) and attaching a pressure gage. With the table speed control set at middle position (just before the table starts to creep), the pressure should read 110 P.S.I. If the pressure is higher than this, there is danger of overloading the $\frac{3}{4}$ H.P. motor.

The low pressure relief valve (Y) is similarly tested. The gage is attached at point F. This pressure should read between 5 to 6 P.S.I. If this pressure is too low, it will be insufficient for lubrication.

Hydraulic Operation. A schematic diagram of the hydraulic circuit is shown on page 22. The pump supplies power to the following cylinders: table, cross slide, table handwheel, cross feed handwheel and downfeed pawl.

Table Circuit. The hydraulic pump is started and stopped by the machine's START-STOP push button on the left of the machine. When started oil will immediately flow to the table speed control valve (T). This valve is actuated by the table throttle lever (G) on the front shelf of the machine. This lever has three positions. First, the OFF position has a by-pass feature which allows the oil to return to the reservoir unrestricted. The two table cylinder lines are also connected together to enable motion of the table by hand. In this OFF position, there will be only 25 P.S.I. or less in the system.

The middle position (just before the table starts to creep) blocks the flow and diverts all the oil through the pressure relief valve. There is then 110 P.S.I. pressure available to perform a cross feed motion. The middle position is the truing position on the machine equipped with power cross feed.

A third position opens a throttle and permits flow at varied rates to the table cylinder. Whenever there is high pressure, the table handwheel disengages automatically through a friction clutch.

Table Reversing. There are two valves required to perform this function: a pilot valve and a table reversing valve. The pilot valve (P) is connected mechanically to the table reverse lever (H). By actuating this pilot valve, the high pressure is directed to one end or the other of the reversing valve, depending on its position. It is the relative position of this reversing valve which governs the table direction.

All three table control valves combine into one valve block (I). This valve block is held by four screws on the left side of the hydraulic panel.

Cross Feed Circuit. This circuit requires four control valves: a cross feed direction valve, a cross feed amount valve, a cross feed control valve and a cross feed truing and rapid positioning valve.

The direction valve is actuated manually by a lever on the right side of the machine (J). This valve has three positions: OFF, IN and OUT. When set for "IN" or "OUT" the oil under pressure coming from the amount valve goes to either side of the cross feed cylinder. At the same time, the cross feed handwheel is disengaged by pressure acting on a half nut against a spring.

The "OFF" position allows both cross slide cylinder leads and exhaust to interconnect. The pressure is also released on the half nut and allows the spring to re-engage the nut.

Cross Feed movement at table reversal is varied by changing the stroke of the amount valve. The stroke is adjusted by turning, in or out, the knurled knob (K) on the right side of the machine. A cross feed control valve is actuated hydraulically at each table reversal. Each time this valve is shifted, high pressure is applied to the cross feed amount valve and diverts the measured oil from the amount valve into the cross feed cylinder.

These three valves are combined into one block (L) and mounted on the right side of the panel. When the power cross feed is not required on the machine, this block is removed and replaced with a blank.

The cross feed selector valve (S) is mounted on the bottom of the cross slide block. It has three positions: truing, grind and rapid positioning. It is actuated manually by the knob (M) at the right side of the machine. There is a mechanical interlock to prevent table and continuous cross slide motion at the same time. When the cross slide is in continuous motion, the high pressure is by-passing the amount valve through the truing valve and cross feed direction valve and on to the cross slide cylinder.

Power Down Feed Arrangement. By removing the pipe plug at the right edge of the hydraulic panel and adding a throttle valve and a flexible hose, pressure is brought up to the down feed valve. With the valve turned on, pressure can be applied to a spring loaded piston attached to a down feed pawl. When the selector valve is off, the pressure to the down feed piston is blocked. Whenever the table reverses at the left end, pressure is applied to the flexible hose from a line between the cross feed amount and cross feed control valves to the down feed cylinder. When the table reverses at the right end, this line is connected to the exhaust and the spring retains the piston pawl. Down feed will only occur at the left end reversal of the table, i.e., with the wheel at the right of the work.

Lubrication. Lubricating oil is supplied directly from the hydraulic system by tapping into the exhaust line in the panel. There will be 5 to 6 P.S.I. pressure at this point which will force the oil through the median unit for lubrication when nec-

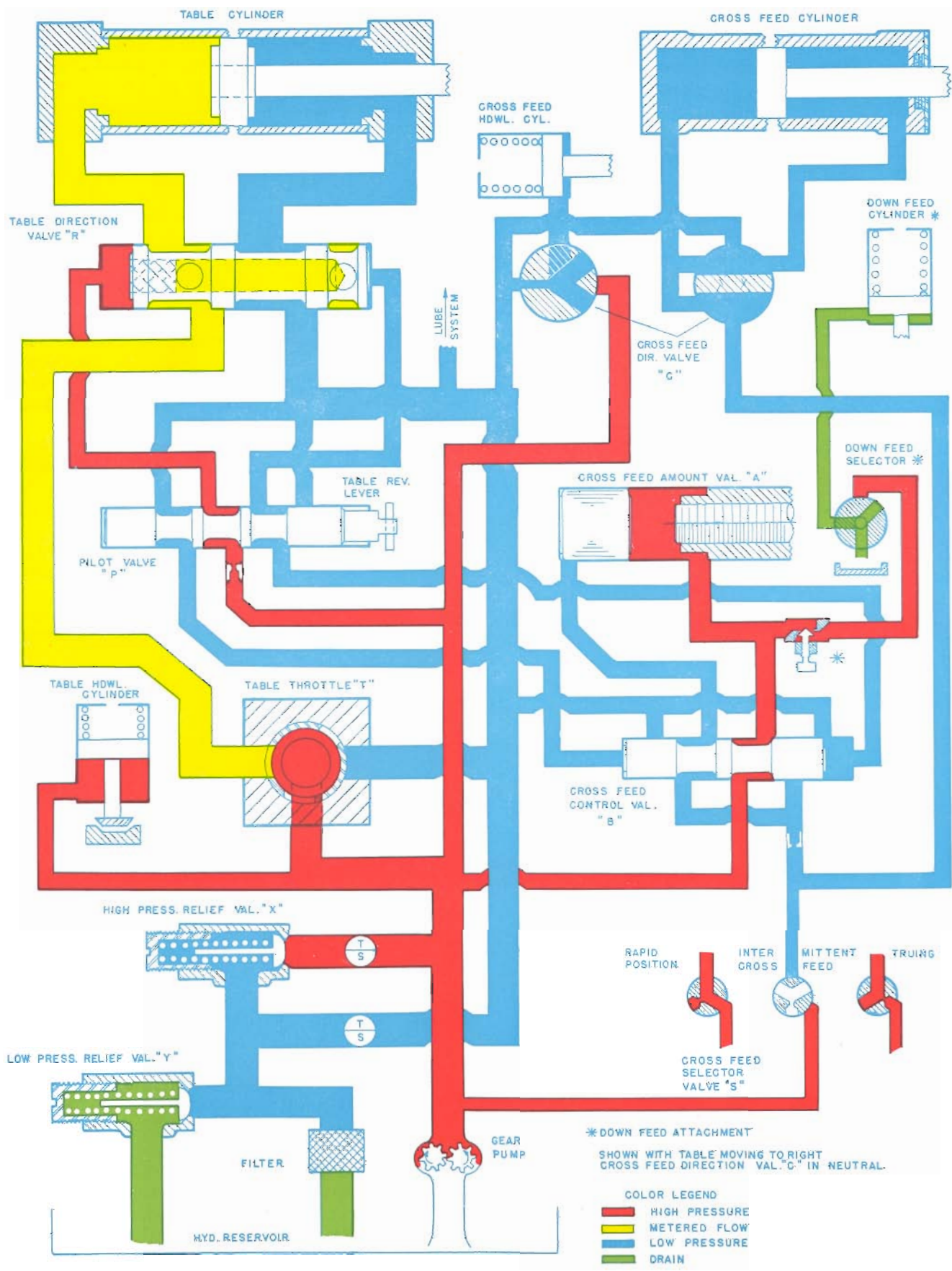

essary. This oil drains back to the reservoir through a filter.

Hydraulic Maintenance

Table Circuit. Table is jumpy: it will be found, when first starting machine, that there will be air in the table cylinder. This can be flushed out by operating the table at high speed, under power, with the table dogs set far apart. Check the high pressure relief valve (X). If you can not obtain the 110 P.S.I. with the throttle valve in its middle position, then the relief valve may be stuck open. If the table is slow to reverse, has excessive over-travel, or no reversal at all, it may be due to clogging of the resistance plug (see hydraulic diagram). This plug is built into the table control block.

Cross Feed Circuit. When set up for intermittent cross feed, the cylinder should be completely free from air. The best way to eliminate this air is by running the slide at rapid position backward

and forward. The fine feed rates are very often erratic with air in the cylinder. If the cross feed is found to be sluggish, it may be due to dirt at the resistance plug (see circuit diagram). This plug is located in the cross feed block.

If the truing speed is too slow, there may be dirt in the orifice located in the cross feed selector valve (S). When down feeding, if the repeat accuracy is erratic, or if there is any shock, a slight adjustment can be made at the throttle valve. This throttle valve is located in a line leading from the right side of the panel to the back of the down feed handwheel. If the lubrication oil is spilling on to the floor, this would indicate a clogged lubrication filter cartridge. This is easily remedied by changing the cartridge. To change the cartridge, remove the collar at the right side of the machine. A large bolt at the top of the filter container should be loosened and the container will drop down exposing the cartridge. This cartridge should be replaced at least once a year.

CHAPTER VII

Grinding Wheels and How to Select Them

Grinding wheels are made of crushed abrasive or cutting grit held together by a substance known as the bond.

Abrasive. The most common abrasives are aluminum oxide and silicon carbide.

Aluminum oxide crystals, though not particularly hard, are tough and hence are usually preferred for grinding materials of high tensile strength such as alloy and high-speed steels. This abrasive is known by such trade names as Borolon, Aloxite, Alundum and others.

Silicon carbide crystals are very hard but quite brittle. Hence, wheels of this material are used in grinding easily-penetrated materials such as copper, rubber and celluloid, and hard materials of low tensile strength such as cast iron and cast bronze. This abrasive is known by the trade names Electrolon, Carborundum, Crystolon and others.

Bond. Differences in bond give the grinding wheels varied characteristics.

Vitrified clay is the bond most commonly used. Wheels of this type are usually preferred for general production and toolroom grinding, for they are unaffected by heat, cold, water and oils and have many other advantages. They are usually not as strong as wheels of other bonds, and have practically no elasticity. Consequently, it is not advisable to attempt a heavy side cut with wheels of this type.

Silicate or semi-vitrified wheels (bonded with sodium silicate) as a rule cut smoothly and with little heat, hence are suitable for work requiring a delicate edge such as cutter or tool grinding.

Shellac forms a strong bond, and very thin wheels made of it are safe. These wheels produce a smooth finish and deep side cuts can be taken.

Rubber forms a bond of great strength, and wheels bonded with this material are used to cut grooves and for similar work.

Grain. This term refers to the size of the particles of abrasive used in the wheel. A 46-grain wheel, for example, is one made of abrasive that will just pass through a 46-mesh screen (that is, a screen having 46 meshes or openings per linear inch).

Several sizes of abrasive are often combined to produce a wheel of special characteristics. Such a wheel is called a *combination* wheel.

The grains commonly used for surface grinding range from 46 to 80. For rough grinding, when the finish is not important, coarse-grain wheels are used. When the finish is more important or the surface to be ground is narrow and requires a

sharp edge, fine-grain wheels are used. Combination wheels usually cut fast yet leave a good finish.

Wheel Structure. This term refers to the spacing between the abrasive particles in the wheel. Since the chips produced from soft, ductile materials will be relatively large, a wheel of open structure is needed in order to give enough chip-space to prevent the wheel from becoming loaded. Hard, brittle materials, yielding smaller chips, are ground most efficiently with a wheel of denser structure. In most cases a wheel of medium structure will be satisfactory, although a change in structure may often result in better grinding and longer wheel life.

Grade. Wheels from which the grit is readily torn are known as soft bond or soft grade wheels, while those that strongly retain the grit are called hard bond or hard grade. Note that the term *grade* refers to the breakdown resistance of the wheel and not to the hardness of the abrasive.

The grade of grinding wheels is designated in different ways by the various manufacturers. In most cases, it is indicated by letters, though some makers employ a numerical system.

In general, hard grade wheels are used in grinding soft steel and similar metals, and soft grade wheels are used on the very hard metals. If coolant is used, the wheel used should be of harder grade than if the job were ground without coolant. Also, the greater the contact between work and wheel, the softer the grade should be. The faster a wheel runs, the harder it will act.

Selection of Grinding Wheels

As indicated above, a most important consideration in the selection of grinding wheels is the nature of the material to be ground. Surface speeds of wheel and work, amount of material to be removed, and accuracy and quality of finish desired, are also matters to be considered.

The abrasive, grain, structure, grade and bond of the wheel regularly furnished with the Brown & Sharpe 618 Surface Grinding Machines are such as to suit this wheel to general-purpose grinding. However, the material, finish requirements or volume of work, may often make desirable the use of a wheel more perfectly suited to the particular job at hand. The various wheel manufacturers publish literature which will be of particular help in selecting grinding wheels of their own make. Or, if desired, all details of the grinding operation may be submitted to the wheel manufacturer for advice and recommendations.

CHAPTER VIII

Optional Mechanisms and Additional Equipment (Furnished at Extra Cost)

Various items of additional equipment available as extras are described and illustrated in this chapter. Instructions are also given on their set-up and use.

These extras include an Exhaust Attachment, Wet Grinding Attachment, Castered Base (for use with Wet Grinding and Exhaust Attachments), Magnetic Chucks, 4 $\frac{3}{4}$ Inch Index Centers, High Speed Surface Grinding Attachment, No. 101-5 Adjustable Vise, No. 202 Adjustable Swivel Vise, No. 421-4 Flanged Vise, Over-The-Wheel Truing Attachment, Radius and Angle Wheel Truing Attachment, Continuous Radius and Tangent Wheel Truing Attachment, Extra Vertical Capacity Parts, Isolation Mounts and Illuminated Dust Guard.

Exhaust Attachment

This attachment removes grit and dust-laden air from the region of the grinding operation and separates out the foreign matter, leaving the air well-cleaned. It is readily moved from one machine to another, and is recommended for all dry grinding operations as a means of providing the necessary protection to the operator and machine. The attachment is shown complete in Fig. 18.

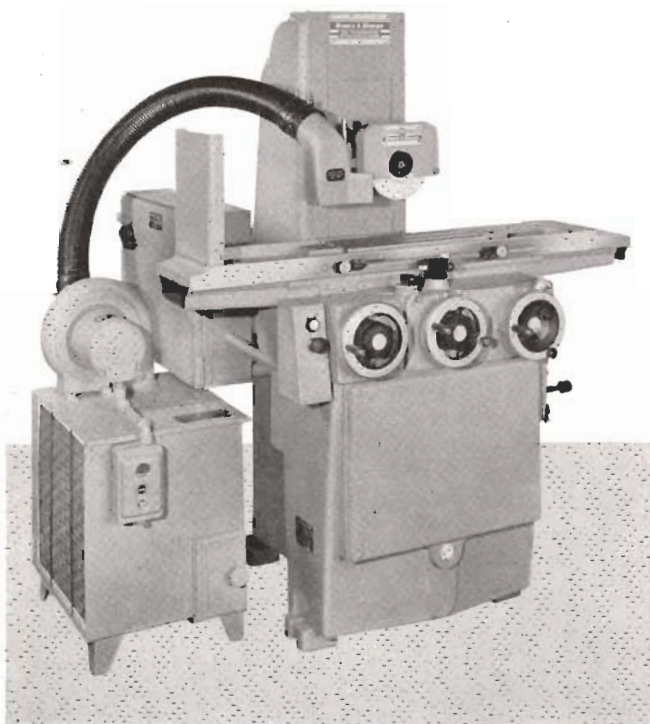

Fig. 18. Exhaust Attachment.

The motor-driven fan on the separator tank draws the air at high speed through a flexible pipe from an adjustable exhaust nozzle attached to the wheel guard and blows it into a spiral separator, where the heavier particles are removed by centrifugal force. The air then passes slowly out through two viscous-coated renewable filter pads which remove the remaining finer particles. The separator chamber is emptied through the vertical sliding gate at the right front of the tank, while the filter pads are released for replacement by lifting out the two vertical rods which hold them in position.

For most efficient dust removal, adjust the position of the exhaust nozzle on its supporting stud so as to keep the nozzle close to the work.

The $\frac{1}{4}$ h.p. fan motor is controlled by a starting switch having overload protection, and is designed to be connected directly to the power line. However, if the grinding machine is fitted with the receptacle used with the Wet Grinding Attachment, the Exhaust Attachment can be equipped with a plug and cable for plugging into the receptacle.

Exhaust Nozzle

for Use with Central Plant Exhaust System

The Exhaust Nozzle (Fig. 19) offers a convenient means for connecting the machine to a central exhaust system. A special stud is included for attaching the nozzle to the wheel guard of the machine and permits adjusting the position of the nozzle. A flexible pipe with a 4" hole is used for connecting to exhaust system.

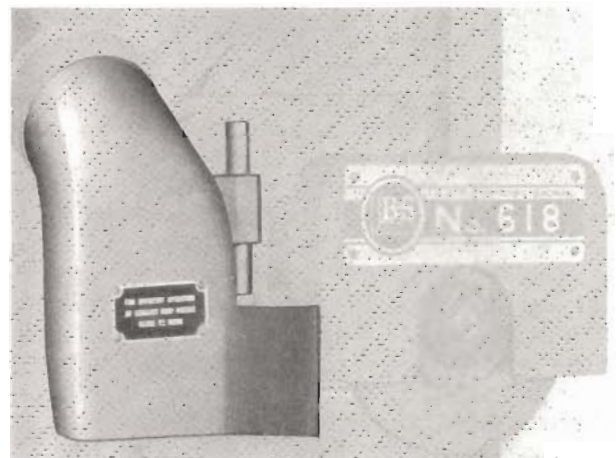

Fig. 19. Exhaust nozzle for use with central exhaust system.

Power Downfeed Arrangement

This hydraulic-mechanical feed arrangement is mounted as part of the elevating handwheel

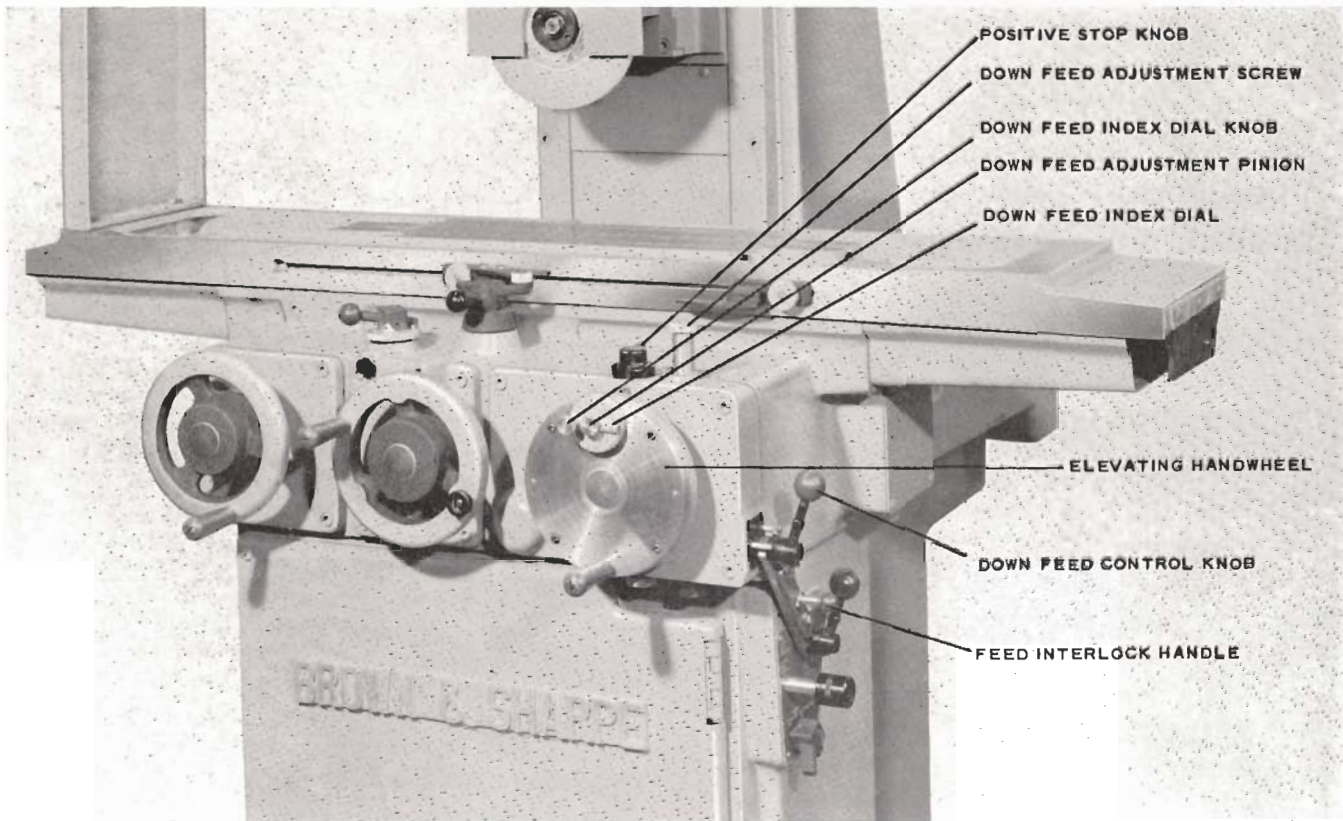

Fig. 20. Power Down Feed Arrangement.

bracket on machines with a hydraulic power table. The ON-OFF control for this arrangement is the downfeed control knob on the right side of the bracket, above and slightly to the front of the power crossfeed directional lever. This control is mechanically interlocked to the crossfeed directional lever on machines with power crossfeed to eliminate the possibility of inadvertently engaging the cross feed while slot grinding. This arrangement provides for downfeeding of the spindle at each alternate table reversal.

The amount of this automatic feed may be varied between 0.000,2" and 0.003" by the Down Feed Adjustment Screw located above and to the right of the elevating handwheel. A positive stop allows termination of the feed at any desired depth up to approximately 0.045". This stop may be retracted to permit automatic downfeeding over the entire range of the wheel slide movement.

The mechanism is designed so that the pawl is completely withdrawn from the tooth spaces of the ratchet wheel during each recovery stroke thereby not scraping the top of the teeth during recovery. This contributes to longer part life and lower maintenance.

Index Dial. The index dial is that segment of the power downfeed arrangement by which fine adjustments are made. The handwheel can be set at zero at the positive stop position and readings

made directly from the index dial. To get accurate readings, it is necessary that the wheel stop bear against the right side of the positive stop. With the handwheel set at the positive stop, the index dial is turned back the desired amount. The mechanism will then feed down the required amount.

If the handwheel has to be turned a considerable distance, pull out the downfeed adjustment pinion in the center of the index dial to disengage the handwheel. Turn the handwheel the required amount and push in the pinion. Then make any necessary fine adjustments by turning the index dial.

Setting the Positive Stop. A pin in the back of the elevating handwheel, located behind the index dial, comes in contact with the right hand side of the positive stop as the wheel is brought down, thus providing a positive stop for the downfeed movement. Reading on the handwheel then is zero. To set the stopping point for the desired finished size of the work, proceed as follows:

1. With the other set-up adjustments completed and a workpiece in place, adjust the handwheel until the grinding wheel just touches the work.
2. Pull out the downfeed adjustment pinion, freeing the handwheel, turn the handwheel until the pin comes against the right hand side of the positive stop.

3. Re-engage the downfeed adjustment pinion. Check the size of the work and make necessary adjustments with a downfeed index dial, always working to the positive stop. The repeat accuracy will then be insured, under normal operating conditions.

Included in this arrangement is a friction device which keeps a drag on the handwheel. This device can be adjusted for individual taste when the handwheel is used manually. This device also prevents backlash of the handwheel when the ratchet is engaged. The adjustment for this device is located below the handwheel.

In addition to the advantages of automatic downfeeding with this arrangement, it is also possible to operate this unit manually. The positive stop can be adjusted for the desired size and the mechanism operated manually rather than waiting for the unit to down-feed automatically at every other table reversal.

Also, the positive stop pin can be located on either side for grinding the front or back of a slot.

Isolation Mountings

This set of four mountings will eliminate the need for expensive machine foundations by completely isolating the machine from external vibration.

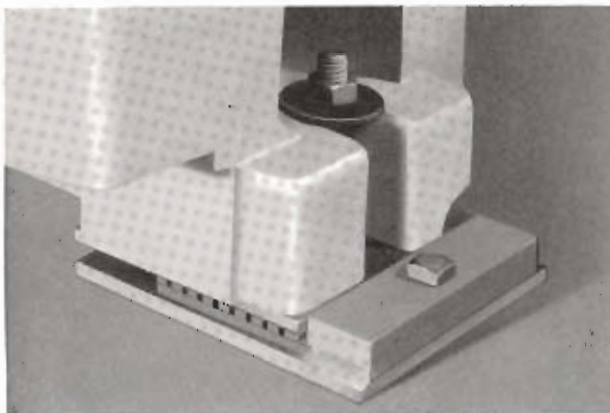

Fig. 21. Isolation Mounting.

Extra Vertical Capacity Parts

Vertical adjustment is increased by using a 4" raising block. This increases the height of the work ground, on a machine having the vertical adjustment handwheel located on the bed, to 18".

This modification is built into the machine at the factory. The machine comes with a Direct-Drive Spindle, a 7" grinding wheel and the Elevating Handwheel is located on the front.

Vertical Rapid Positioning Arrangement

For increasing production, this arrangement with a push-button controlled motor positions the

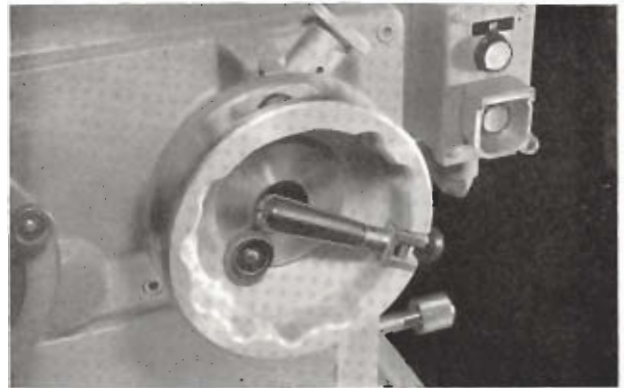

Fig. 22. Handwheel for Vertical Rapid Positioning Arrangement.

grinding wheel vertically at the rapid rate of 40 inches per minute.

Illuminated Dust Guard

This guard provides a bright background for such jobs as form grinding, etc. It fits over the dust guard (standard equipment) located on the left end of the table. Fluorescent tubes mounted behind frosted safety glass provides an excellent background for the operator.

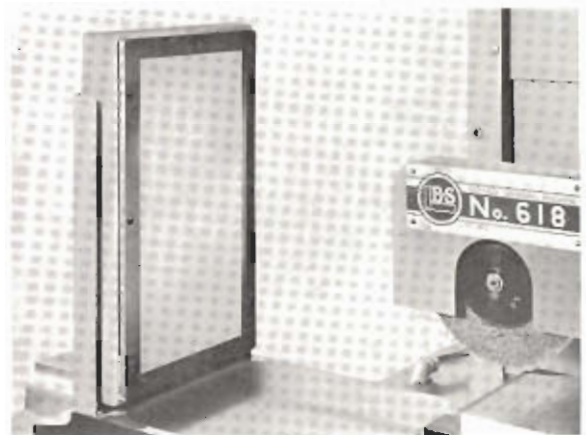

Fig. 23. Illuminated Dust Guard.

Wet Grinding Attachment

The Wet Grinding Attachment Pump Motor connects into a receptacle at the back of the machine. This receptacle is energized by the spindle START-STOP button on the left side of the machine.

The Wet Grinding Attachment Coolant is supplied to the wheel through a nozzle and flexible piping from a 1/4 H.P. motor-driven centrifugal pump mounted in the supply tank (Figure 24). A plug, receptacle, overload relay and wiring are included.

The working surface of the table is surrounded by a three-piece overlapping splash guard, a guard for the right end, and the deflector at the left end of the table.

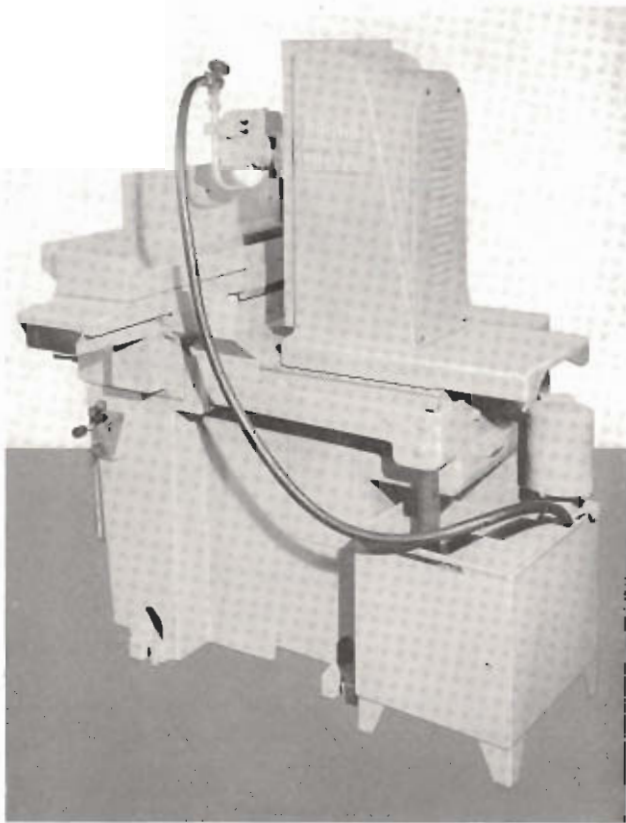

Fig. 24. Wet Grinding Attachment

Coolant collects in the table channels and is delivered to a trough in the bed at the rear of the table which then discharges into a trough at the side of the machine and goes to the supply tank through a flexible hose. The 18-gallon floor type tank is of welded steel and has a two-plate removable baffle unit which provides for efficient setting.

Castered Base for Use with Wet Grinding and Exhaust Attachments

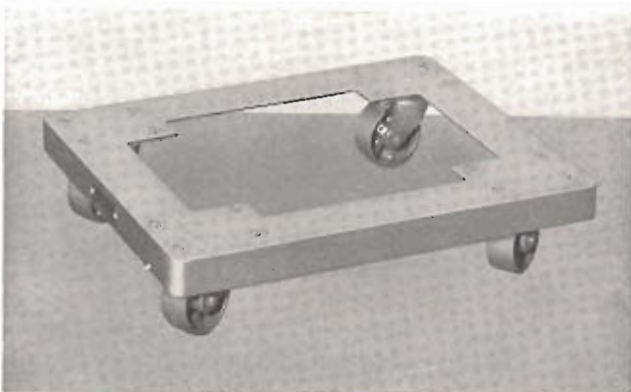

Fig. 25. Castered Base.

The castered base or dolly (Fig. 25) provides a ready means of moving the coolant tank or separator tank to other machines or to a convenient place for emptying and cleaning. It is sturdily constructed of heavy steel, is equipped with ball bearing casters and fits into the corners formed by the feet of the tank, raising the feet about $\frac{1}{4}$ " off the floor to permit free movement.

It measures $19\frac{1}{2}$ " long, $15\frac{1}{2}$ " wide and $3\frac{7}{8}$ " high.

$4\frac{3}{4}$ Inch Index Centers

These Index Centers (Fig. 26) permit accurate indexing of the more common circular divisions, facilitating the grinding of taps, reamers, formed cutters and similar work. The centers are clamped in position by T-bolts and are aligned by tongues which fit the table T-slots.

A spring-loaded locking pin on an adjustable arm, together with six rows of holes in the face of the combined index plate and worm wheel, provide for indexing all divisions from 2 to 14 and all even-numbered divisions from 18 to 28. The index plate can be turned by the worm, or the worm can be thrown out of mesh and the index plate turned by hand. To disengage the worm, loosen the adjacent clamp screw and swing the worm downward.

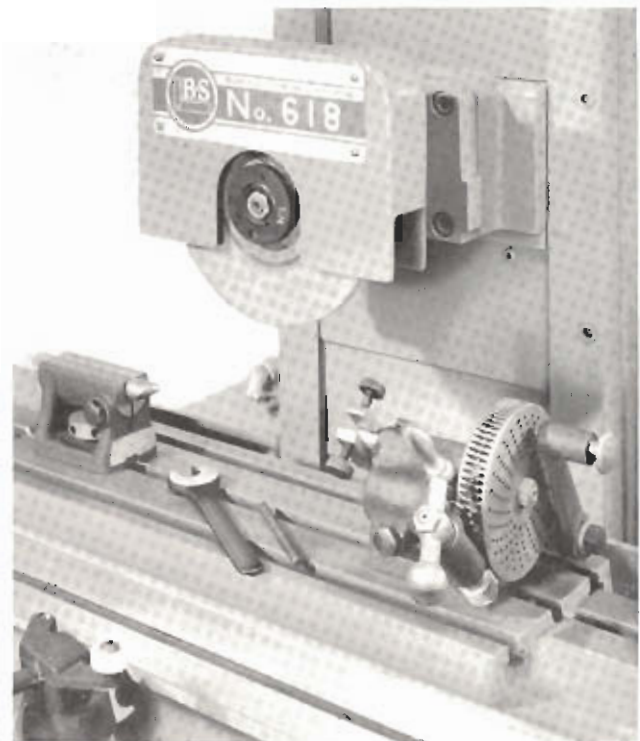
Fig. 26. $4\frac{3}{4}$ Inch Index Centers

In using the Index Centers for sharpening formed cutters or similar work having radial tooth faces, first turn the cross feed handwheel to

bring the face of the grinding wheel in line with the index centers. Then, with the work mounted between centers, disengage the index pin and turn the worm to feed the face of a tooth into the grinding wheel, feeding the work a small amount and running the table back and forth by hand in successive steps until that tooth is properly sharpened. Next loosen the index pin arm, insert the pin in a hole in the proper circle and securely clamp the arm.

In sharpening the rest of the teeth where a considerable amount of stock is to be removed from each tooth face, feed the work to the grinding wheel by means of the worm to take the necessary number of successive cuts on each face until the index pin enters the proper hole. In case the grinding wheel requires dressing before all of the teeth are sharpened, readjust the position of the grinding face of the wheel relative to the index centers after dressing the wheel. Moving the Spindle Slide Upright to bring the Grinding Wheel into contact with the face of the last tooth ground is generally efficient. After sharpening the remainder of the teeth, a final adjustment of the Spindle Slide Upright may be necessary for required accuracy, after which a light finishing cut all around will compensate for errors due to wheel wear.

The centers as illustrated in Fig. 26, swing work up to $4\frac{3}{4}$ " diameter. Used with raising blocks (available at extra cost), the centers swing work up to $8\frac{1}{4}$ " diameter.

Centers have reversible tongues for T-slots $\frac{1}{2}$ " or $\frac{9}{16}$ " wide.

High Speed Surface Grinding Attachment

Slots and other surfaces which do not permit the use of a wheel of large diameter can be ground with this attachment. The attachment spindle is mounted on super-precision ball bearings and is belt-driven from a pulley mounted on the spindle of the machine.

As shown in Fig. 27, the attachment body fits onto the machine spindle sleeve in place of the wheel guard and can be used in practically any angular position around the machine spindle. With the attachment spindle in the lowest position, the maximum vertical distance between center of the attachment spindle and top of machine table is 12" with the handwheel on the upright, this distance is reduced to 10".

To install the attachment, remove the grinding wheel and wheel guard from the machine and slip the attachment bracket onto the spindle sleeve. Then, attach the driving pulley and the belt. Next place the guard over the pulley and fasten. Finally, bring the attachment spindle to the desired angular position around the machine spindle, turn the

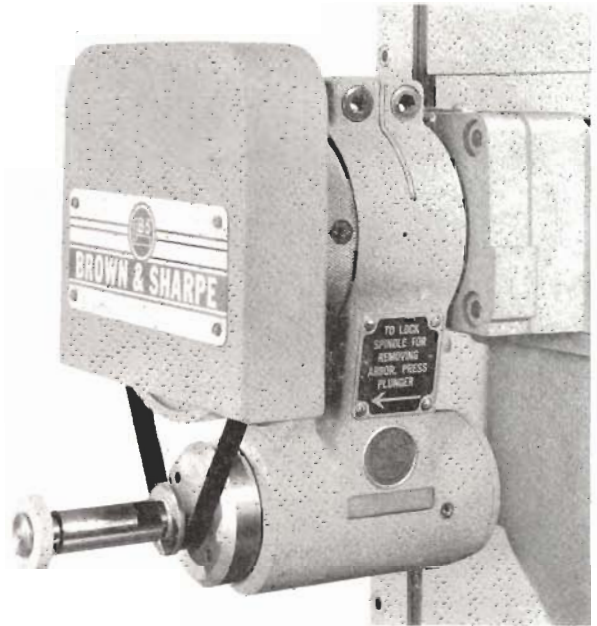

Fig. 27. High Speed Surface Grinding Attachment. Wheel arbors and grinding wheels are furnished at extra cost.

large knurled shoulder behind the belt guard to adjust the belt tension, and clamp both of these adjustments by tightening the rear hollow-head screw at the top of the attachment body. Make sure that the other hollow-head screw is also tight before grinding.

The spindle is grease-packed and requires no lubrication.

A variety of wheel arbors and grinding wheels are available at extra cost. The exacting limits and fine finish demanded of this equipment require extreme accuracy in the taper fit between spindle and wheel arbor. Therefore, we strongly recommend that all wheel arbors be furnished by us to assure the utmost in precision and finish.

In changing wheels or arbors, a spring-loaded plunger in the front of the attachment body above the spindle can be pushed in to hold the spindle from rotating. Make sure that the spindle hole and arbor shank are perfectly clean before inserting an arbor, and seat the arbor firmly in the spindle. Keep in mind that the arbors have a left-hand thread. Never put a cold arbor in a warm spindle; for when the arbor expands (or the spindle cools and contracts), the taper fit will be so tight that removal of the arbor will be difficult.

No. 101-5 Adjustable Vise

The vise proper is mounted on a hinged base and can be set and clamped at any angle in the vertical plane up to 90° , a dial graduated to degrees indicating the setting. Removable tongues in the base provide for aligning the jaws parallel to the table T-slot.

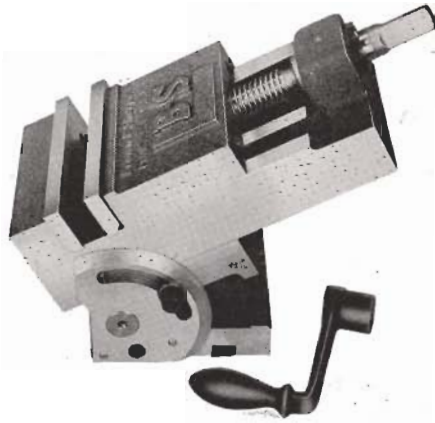

Fig. 28. No. 101-5 Adjustable Vise

The removable jaws are of tool steel, hardened and ground, $4\frac{1}{4}$ " wide and $1\frac{1}{8}$ " deep, and open 2". Distance from bottom of base to top of jaws with vise horizontal is $4\frac{5}{8}$ ".

No. 202 Adjustable Swivel Vise

As illustrated in Fig. 29, this vise can be clamped to the table with the jaws at any horizontal angle to the table T-slots. The jaws can also be tilted in a vertical plane to any angle up to 45° each side of horizontal. The latter setting is indicated by a scale graduated in degrees and is clamped by the nut at the right.

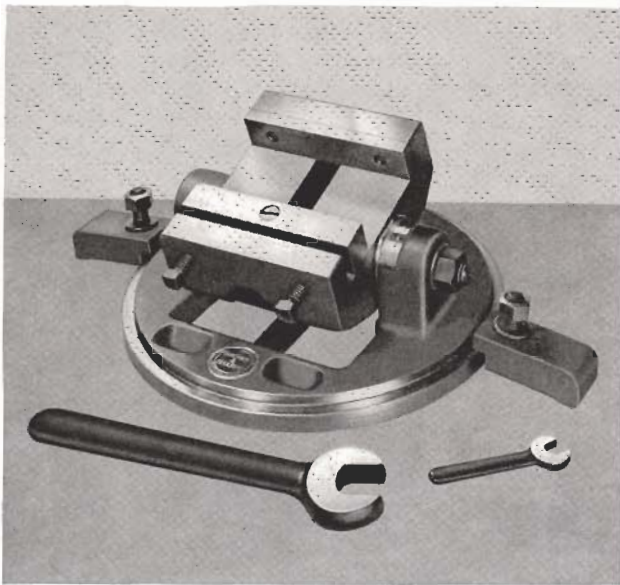

Fig. 29. No. 202 Adjustable Swivel Vise.

The hardened tool steel jaws are 5" wide, 1" deep and open $2\frac{3}{4}$ ". The movable jaw is opened and closed by the two screws at the front. With the jaws horizontal, the distance from bottom of base to top of jaws is 4".

No. 421-4 Flanged Vise

This vise can be clamped at right angles or parallel to the wheel spindle.

The removable jaws are of tool steel, hardened and ground, $4\frac{1}{4}$ " wide and $1\frac{1}{8}$ " deep, and open 2". Distance from bottom of base to top of jaws is 3".

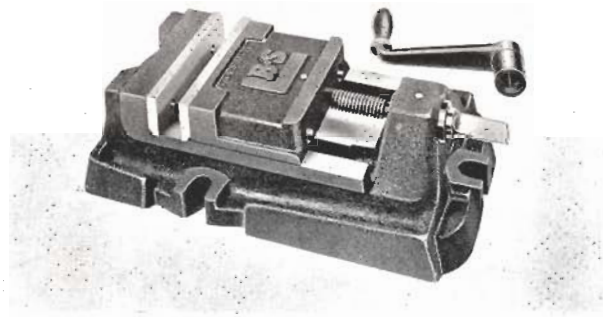

Fig. 30. No. 421 Flanged Vise.

Over-The-Wheel Truing Attachment

The Over-The-Wheel Truing Attachment greatly reduces the time required for wheel truing. It can be used on the majority of everyday jobs where *extreme* accuracy is not required. With this Attachment the diamond remains close to the wheel, ready for immediate use and the work-piece remains undisturbed beneath the wheel.

Before using the attachment the top of the template on the right-hand side (beneath the ball handle) must be made parallel to the top of table. This is done by using a dial indicator mounted on the machine table and moving the Spindle Slide Upright transversely. Any adjustment necessary

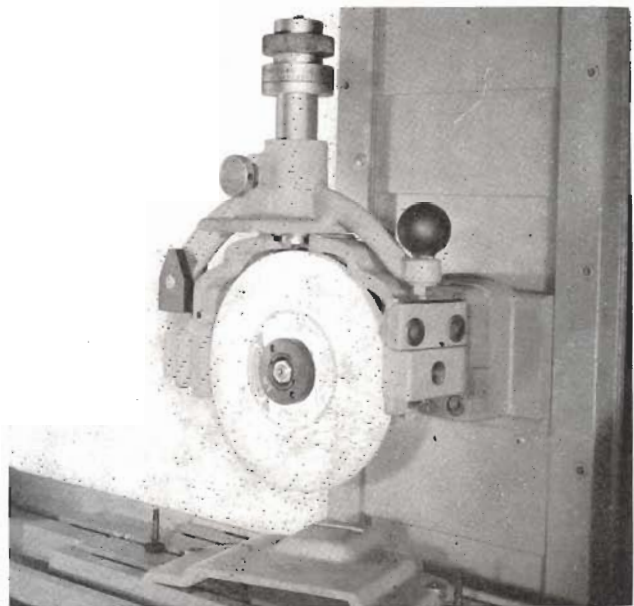

Fig. 31. Over-the-Wheel Truing Attachment shown with wheel guard cover removed.

is made by means of the two screws upon which the template rests.

To start the initial truing, the scale at the top of the attachment is turned to read zero. The knurled screw at the front is then loosened, the diamond brought into contact with the wheel, and the diamond carrier clamped. The ball handle at the right of the attachment is then moved back and forth with the stylus beneath it in contact with the template. This moves the diamond across the wheel to true it.

After the initial truing of the wheel, the operation of this attachment is extremely rapid. The diamond is fed into the wheel by turning the knurled knob at the top of the Attachment. Then the diamond is passed across the wheel by moving the ball handle. After the wheel is trued, the wheel is lowered an amount equal to that trued off the wheel as indicated on the scale at the top of the attachment. This brings the grinding surface of the wheel into the same position with relation to the surface being ground as it was before the wheel was trued.

Included with this attachment are (1) a special wheel guard and cover, (2) a coolant nozzle and bracket for use when the attachment is used with a Wet Grinding Attachment.

The diamond (approximately one carat) is available at extra cost.

Radius and Angle Wheel Truing Attachment

This Attachment provides a ready means of forming wheels with accurate convex or concave

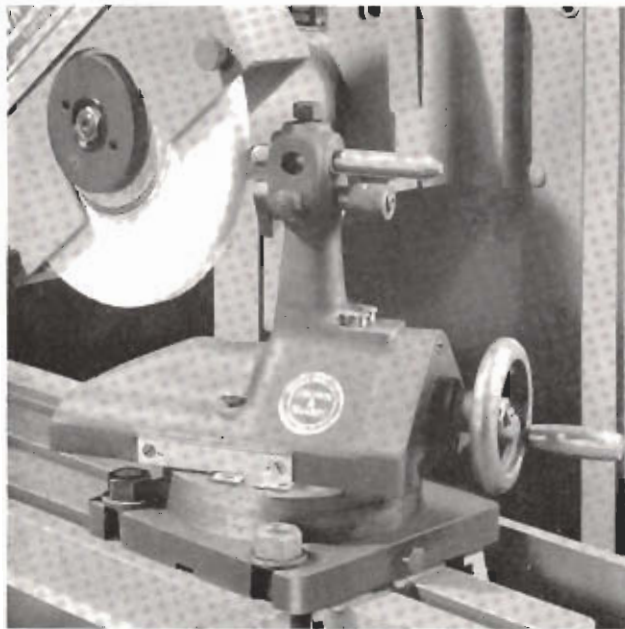

Fig. 32. Shaping a radial contour with Radius and Angle Wheel Truing Attachment. The slide is clamped at the required radius, the diamond tool is set by the gage just below it and the slide is swiveled to form the wheel.

outlines up to 1" in radius and face angles up to 90° either side of zero, and permits combinations of radial and angular shapes to be developed.

The base of the attachment carries a swivel platen upon which is mounted a slide which can be moved longitudinally by handwheel. A gib and adjusting screw provide means of compensating for wear in the slide. The base is keyed for accurate alignment.

To form concave or convex outlines, clamp the diamond tool (diamond not furnished) in the upright parallel to the slide as shown in Fig. 32, locating the diamond point by means of the diamond tool setting gage (turned upward 180° from the position shown). Adjust the slide by handwheel to the desired radius as shown by the scale on the side, setting the slide to the right of center to form a convex shape on the wheel and to the left of center to form a concave shape. Tighten the clamping screw on the back of the slide (not visible in illustrations) to lock the adjustment, and pass the diamond across the wheel by swiveling the attachment on its base.

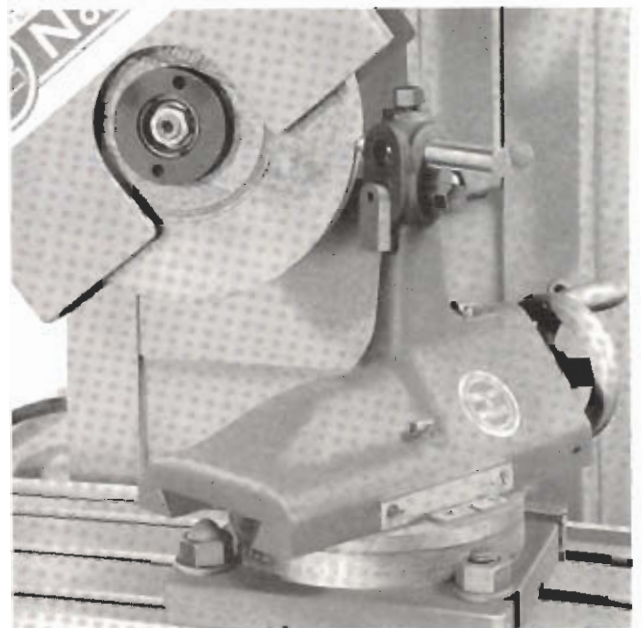

Fig. 33. Forming an angle. The swivel platen is clamped at the required angle and the slide is operated by the handwheel to true the wheel. In both cases the diamond is advanced by hand feed of the machine table.

To true a wheel to an angle, swivel the slide to the desired setting as indicated in degrees by the scale on the base and tighten the clamp screw in the front of the base. Clamp the diamond tool in the upright at right angles to the slide (see Fig. 33) and pass the diamond across the wheel by running the slide back and forth by handwheel.

In either case, to obtain the desired shape adjust the height of the spindle head to bring the center of the spindle horizontal with the diamond point.

Continuous Radius and Tangent Wheel Truing Attachment

This attachment (Fig. 34) is designed to form, with one continuous movement of the diamond, accurate radii on grinding wheels with accurate tangents at either or both sides of the radii. Convex radii up to $\frac{1}{2}$ " , with tangents to $\frac{3}{8}$ " in length in any direction from parallel to the side of the wheel to 110° away from the side, can be formed. Concave radii from $\frac{1}{32}$ " to 1" (larger radii with diamonds having longer holders than one furnished), having tangents up to $\frac{3}{8}$ " long in any direction from 70° to 180° away from the side of the wheel, can also be formed. The angles of the tangents are independent of each other (on a concave shape having a radius over $\frac{3}{8}$ " the included angle must be 90° or more).

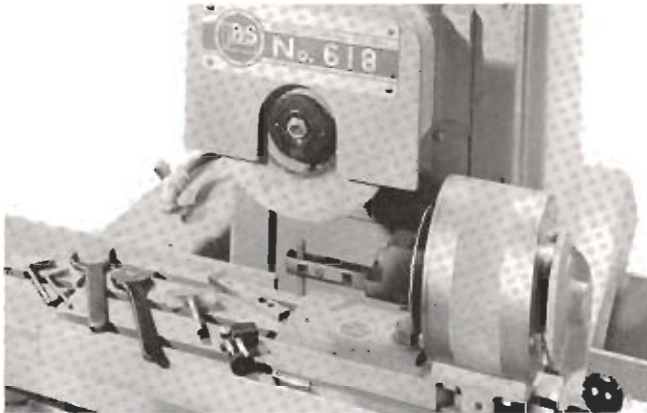

Fig. 34. Continuous Radius and Tangent Wheel Truing Attachment and its equipment (including diamond, mounted). An attractive metal case is furnished.

Concave radii less than $\frac{3}{32}$ " and all concave radii $\frac{3}{8}$ " or less having the included angle of the tangents less than 90° , require diamond tools other than the one furnished.

The attachment is firmly clamped to the machine table by a single T-bolt. Accurate alignment is assured by two reversible tongues for T-slots $\frac{1}{2}$ " or $\frac{3}{16}$ " wide. These tongues are easily removed when the attachment is to be used on a magnetic chuck.

Detailed specifications furnished on request.

Magnetic Chucks

The Brown & Sharpe rectangular-model Permanent Magnet Chucks provide a quick, easy means of holding a variety of ferrous work for surface grinding. A 180° movement of the control lever (see Fig. 35) turns the chuck on or off. Since the chuck does not use electric current, it can be left turned on for as long as desired without heating. Auxiliary top plates are available to permit holding smaller work than can usually be held on a magnetic chuck.



Fig. 35. Brown & Sharpe Permanent Magnet Chuck.

For highest accuracy in grinding work parallel, the top surface of the chuck should be ground each time the chuck is mounted on the machine. Be sure that the chuck is turned on before doing this, and remove only the minimum amount of metal required to grind the entire top surface.

The chuck should not be subjected to excessive heat, shocks or blows, and the top should be kept free from pits and scratches. Regrind the top surface occasionally if necessary, as a smooth surface is essential for grinding work parallel.

Two removable stop plates are furnished with each chuck, one for the back and one for the left-hand end. These stop plates may be adjusted vertically to suit the work.

Wet grinding is preferable to dry grinding if the machine is equipped for this in order to reduce the possibility of distortion in the top plate which might be caused by heat from the grinding.

Chuck No.	Working Surface, Inches	Magnetic Surface, Inches (Approx.)	Height of Chuck, Inches
510-1	$5\frac{1}{8} \times 10\frac{1}{4}$	$3\frac{7}{8} \times 8\frac{13}{16}$	2
510-4	$5 \times 10\frac{3}{32}$	5×8	$2\frac{5}{8}$
612	6×12	$4\frac{13}{16} \times 10\frac{11}{16}$	$2\frac{3}{8}$
618-2	6×18	$4\frac{9}{16} \times 15\frac{1}{2}$	$2\frac{1}{2}$
618-4	6×18	$6 \times 15\frac{3}{4}$	$2\frac{1}{2}$

Electromagnetic chucks and controlling equipment together with a rectifier and neutrofrer are also available. Information on application.

Sine, Perma-Sine and Permanent Magnet Sine Plates

The Brown & Sharpe Inspection Sine Plates offer reliable means for establishing precise angles for surface grinding, for tool making, for inspection

— for work wherever precision angular settings are required. With an overall accuracy within .0002", they give angular settings at gage block accuracy.



Fig. 36. Compound Sine Plate

Simple and Compound Sine Plates are available in 5" and 10" sizes. The simple 5" size working surface is 3½" x 6", the 5" compound working surface is 6" x 6". The 10" size working surface is 6" x 11".

Sine plates are furnished with side and end plates, held in place by knurled-head screws and have tapped holes in their sides, ends and top for the application of clamps or other holding devices.

Lower hinge on compound plates (Fig. 36) can be furnished on opposite end if desired at no extra cost.

The Brown & Sharpe No. 510 Permanent Magnet Chucks can be used with either 10" Sine Plate by adding two bolt holes to the base of chuck. When ordering chuck for this purpose so specify.

The Simple and Compound Perma-Sines are available in the 5" and 10" sizes. The 5" simple and compound plates have a working surface 6" x 6". The 10" simple and compound have a working surface of 6" x 12".

With an overall accuracy within .0002" all over, they give angular settings at gage block accuracy.

No electric connections are needed and the holding power is turned on or off by a turn of the lever.



Fig. 37. Compound Perma Sine.

The Compound Plate (Fig. 37) is superbly suited for complex angles.

Perma-Sines are furnished with both end and side plates, held in place by knurled-head screws.

Lower hinge on compound plates can be furnished on opposite end if desired at no extra cost.

Mist Coolant Arrangement

This arrangement combines compressed air with coolant to develop a mist that evaporates on contact with the work, cooling as it evaporates. Full-time visibility of the work is provided.

A solenoid valve connected to the machine's electrical circuit synchronizes the starting of the mist

Fig. 38. Flexible Distributor.

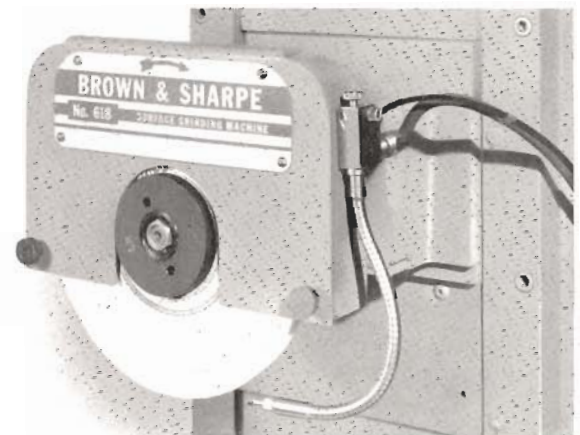

stream with the starting of the machine.

Precision control of mist is provided by a needle valve on the jet. This valve permits accurate control from a very fine mist to a heavy spray. There is never any flooding or "sputtering". The mist is generated right in the end tip of the jet. There is no condensation in tubes, and no dripping or spurting of coolant when starting or stopping.

Fig. 39. Coolant Reservoir.

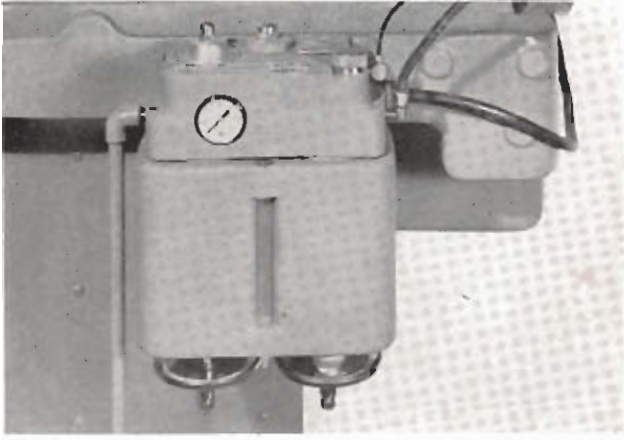

Vertical Position Indicator

The Vertical Position Indicator greatly reduces set-up time by permitting rapid accurate vertical

positioning of the grinding wheel. This eliminates the time wasting motion of "feeling" for the work piece. The arrangement is adjustable over the entire vertical range of the grinding wheel.

Wheel position is indicated by a dial indicator precisely adjusted with a micrometer. Position is easily detected by noting the dial indicator reading.

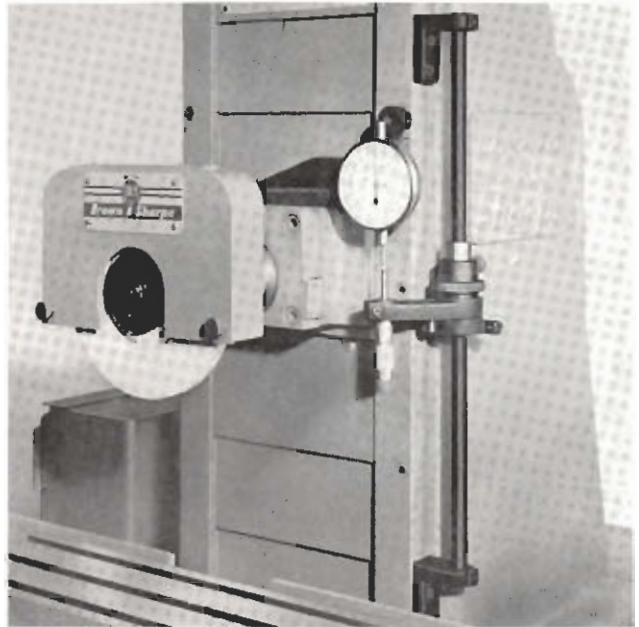

Fig. 40. Vertical Position Indicator.

The Brown & Sharpe line includes the following.

Milling Machines — Plain, Universal, Rangemaster, and Vertical.

Attachments: Milling Cutters, Arbors, Adapters and Collets.

Grinding Machines — Universal, Plain, Surface, Universal and Tool. Attachments and Grinding Equipment.

Screw Machines — Automatic, Automatic Forming and Cutting-Off, and Automatic Chucking.

Attachments: Spring Collets, Feeding Fingers, Screw Machine Tools and Cams.

Turret Drilling Machines — Hand, Semi-automatic, Automatic and Tape Controlled.

Accessories-Attachments: Work Positioning Tables (manual and tape controlled), Work Orientation Devices, Tool Holding Devices and Fixtures.

Machining Centers — Semi-automatic, Automatic and Tape Controlled.

Accessories-Attachments: Work Orientation Devices, Tool Holding Devices and Fixtures.

Other Brown & Sharpe Products:

Precision Tools and Gages, Electronic Measuring Equipment, Gage Blocks, Cutting Tools (High Speed Steel and Carbide), Permanent Magnet Chucks (Rectangular and Rotary), Vises (Plain, Flanged, Swivel, and Toolmakers' Universal), and Hydraulic Products (Pumps, Valves, and Power Units).

BROWN & SHARPE MFG. CO.

Precision Park, North Kingstown, R. I., U. S. A.