

*Installation,
Operation and Maintenance*

INSTRUCTIONS

and

PARTS LIST

for

Model No. 12

**Van Norman Ram Type
Milling Machine**



VAN NORMAN COMPANY

Springfield, T. Massachusetts, U. S. A.

Installation, Operation and Maintenance Instructions for

MODEL No. 12 VAN NORMAN RAM TYPE MILLING MACHINE

The No. 12 Van Norman Ram Type Milling Machine is a precision tool, built of the best material obtainable and to the highest degree of accuracy. Each machine and its parts are checked many times during construction for both quality and accuracy. With ordinary care and observance of the suggestions in this booklet your No. 12 Van Norman Ram Type Milling Machine will give you many years of satisfactory service.

In the general operation of the No. 12 Milling Machine it is important to note that this machine can be used for an exceptionally wide range of milling operations with the minimum of effort on the part of the operator.

In milling operations involved on most jobs where one or a few pieces are required, much time can be saved and the highest degree of accuracy will be assured, by keeping in mind at all times that your No. 12 Van Norman Ram Type Milling Machine has as an important part of its design, a spindle which can be instantaneously adjusted to any angle between horizontal and vertical. Also, the spindle cutterhead is adjustable in or out with respect to the column by means of the ram on which it is mounted; thereby providing added range and adaptability to a wide range of milling operations with the minimum of changes in setups.

Before setting up the piece to be milled it is suggested that the operator carefully analyze the operations to be done in order to position the piece for most advantageous use of the horizontal, vertical and angular adjustments of the cutterhead as well as adjustability of the ram unit.

VAN NORMAN COMPANY, Springfield 7, Mass., U. S. A.

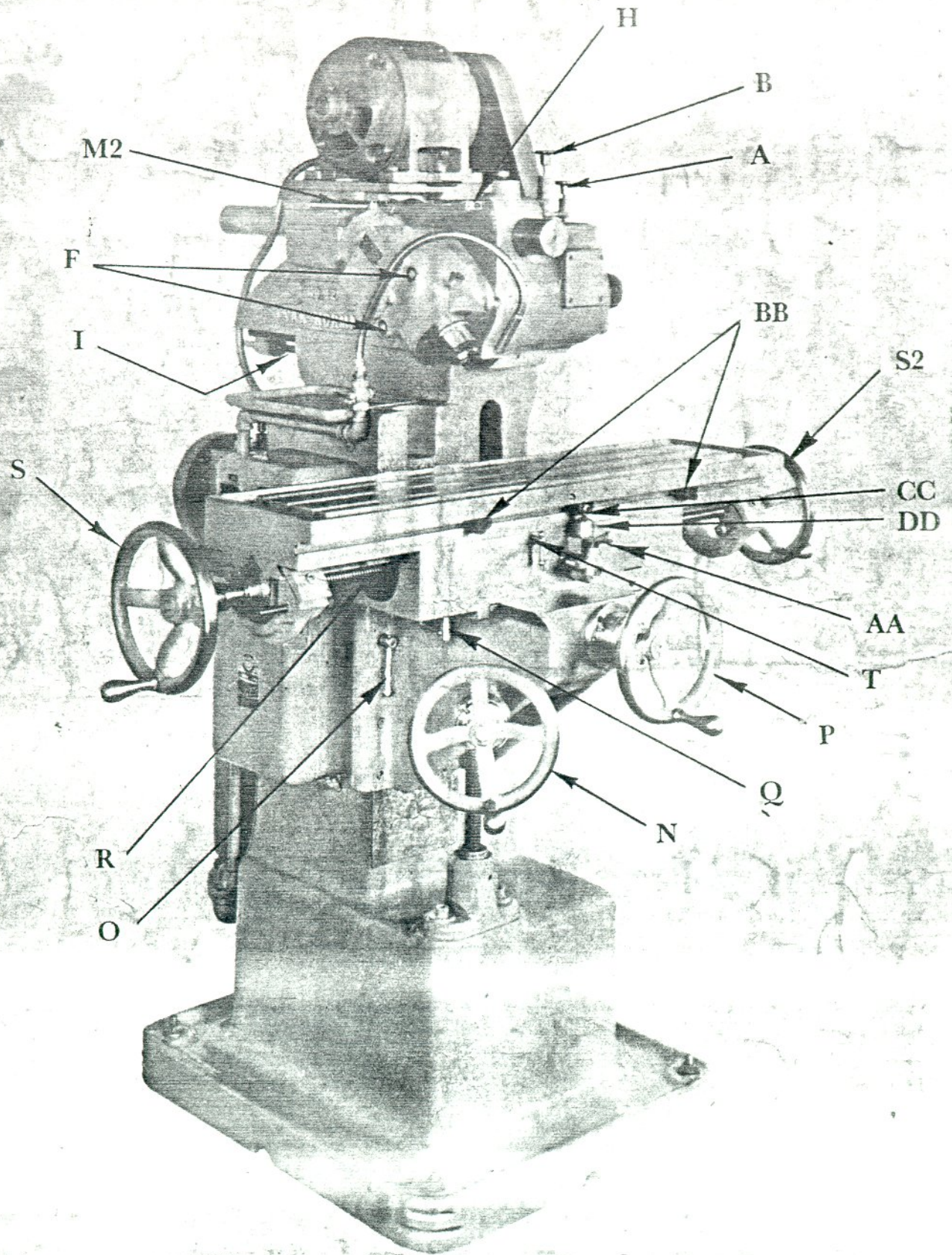

FIG. 1—Left Front View

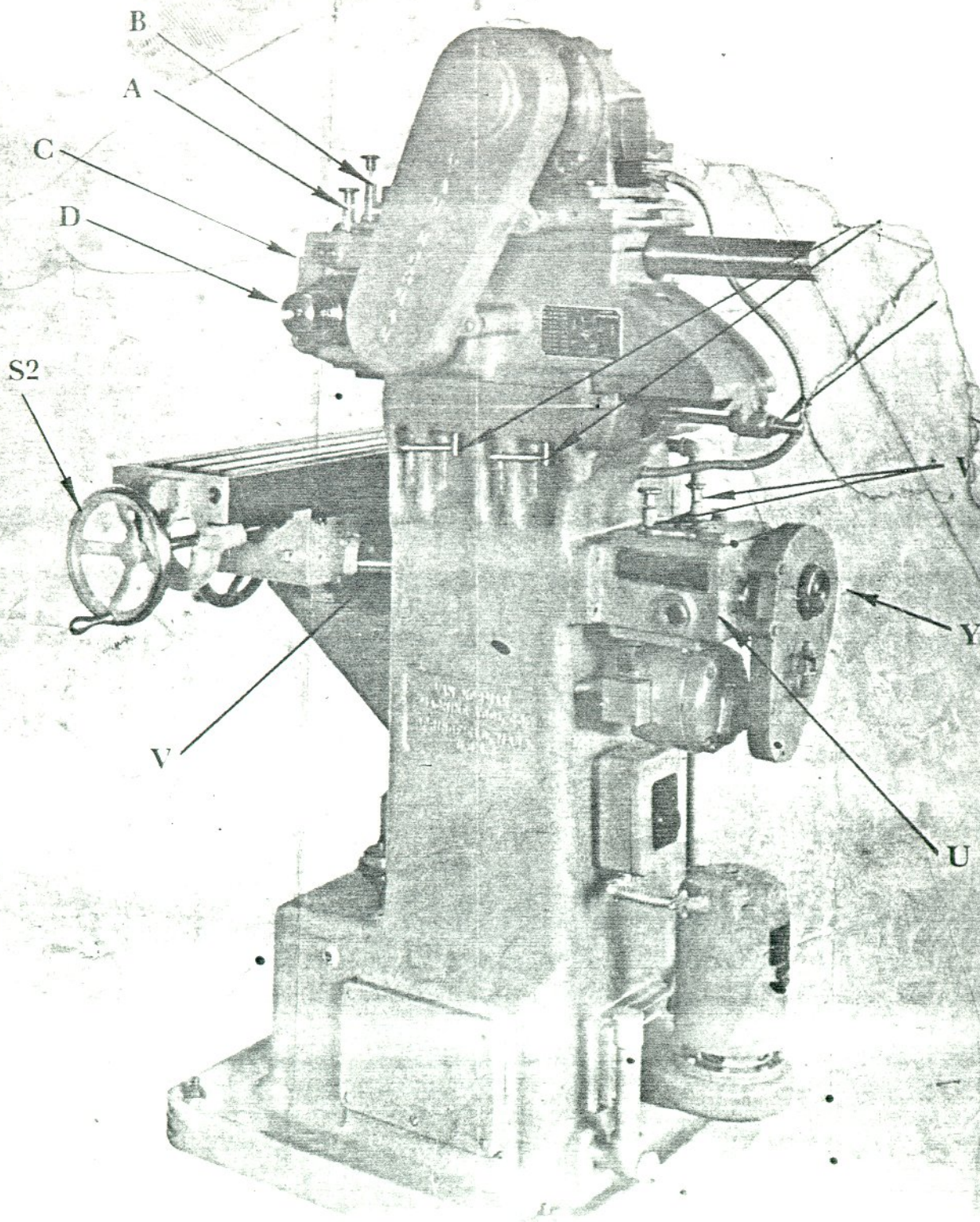

FIG. 2—Right Quarter View

"skid" the
it into place
, it is most im-
applied to pre-

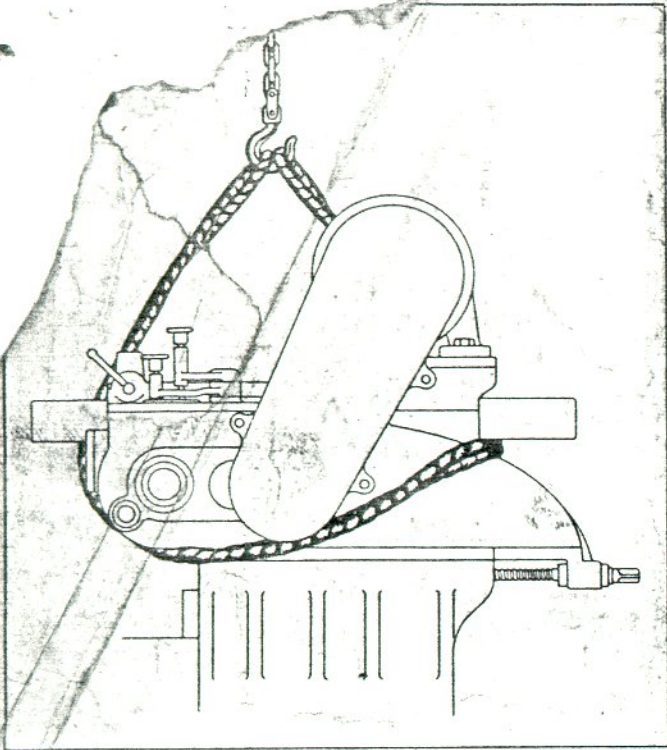

FIG. 3—Slinging Method

vent permanent misalignment in the machine. A sling of $\frac{3}{4}$ " diameter rope about 12' in circumference or longer, should be placed around the ram, as shown in Figure 1, the hook being located about parallel to the ram shifter shafts, with ram 3' ahead of column and on the right side of the ram. Test the lift for balance before lifting to any height.

CAUTION: Do not allow sling to come against the ram feed screw, as it may cause damage; keep it high on the back of the ram under the overarm, as shown. Avoid other methods of slinging, as they may either spring the machine, or upset it as it is lifted.

Leveling

It is essential to the accuracy of the milling machine that it be properly leveled. This should be done by the use of a long spirit level mounted on the table, both longitudinally and transversely. If leveling blocks are used, these should be placed at the four corners of the base, as well

as one on each side midway between the rear and front edges. If leveling blocks are not used, the concrete floor should be as smooth as possible, and tapered wedges or shingles, should be inserted in any openings so that the base receives as much foundation as possible. Lag screws must be used for securing the machine to the floor after leveling.

Initial Cleaning and Preparation for Operation

The machine is shipped with slushing oil on all ways and machined surfaces to prevent rust during shipment. This slushing oil should be washed off with kerosene or other dissolving agent to make sure that all surfaces are free from residue or dust which might have accumulated. Then all slide ways and flat surfaces should be carefully covered with lubricating oil, after which it is advisable to move the table, saddle and knee by hand so that this oil will thoroughly work onto the surfaces. Before operating machine, check all oil levels, and oil and grease in accordance with instructions under "Lubrication" on page 5.

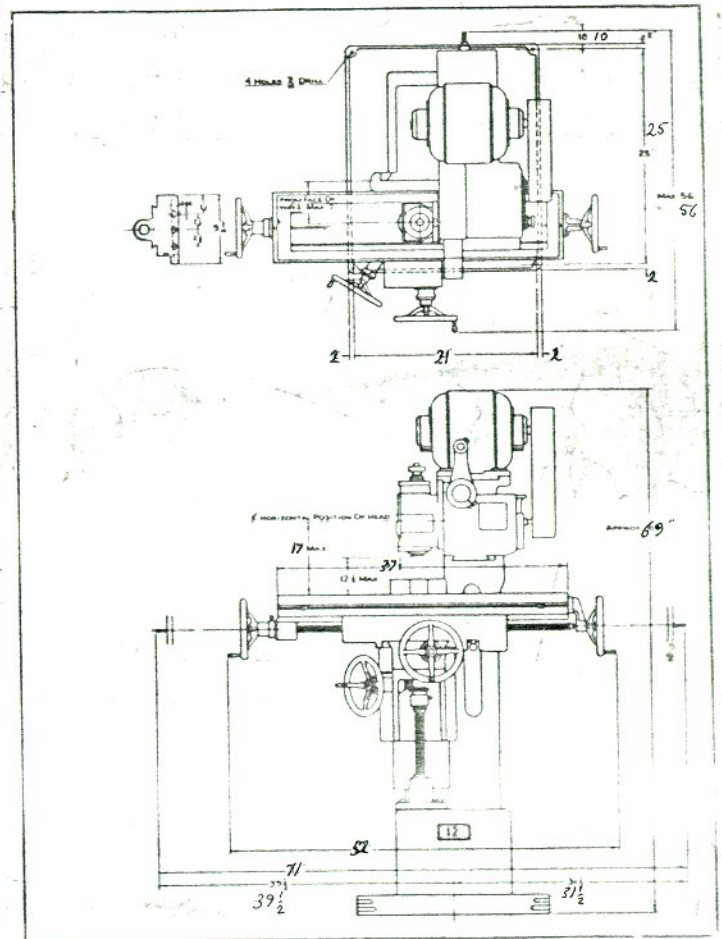

FIG. 4—Erection Dimensions

Wiring and Electrical Controls

Motors and starters of various makes are installed at customer's option. Regardless of make of starters, the starting system remains essentially the same: A reversing switch is provided for the cutter motor; a starter, with an on-off-switch, is provided for the feed motor, which is wired in such a way that it cannot operate unless the cutter motor is in operation. The on-off-switch is used to disconnect the feed motor should hand operation be used for extended periods.

When the power lines are brought into the controls, the connections should be so made that the feed motor rotates *clockwise* when facing the feed motor from behind the machine.

If a coolant system is provided, the coolant motor switch may either be mounted separately on the rear of the column near the pump, or may be included in the single case on the left side of the column. If of the latter type, the switch is wired such that the pump cannot operate unless the cutterhead motor is in operation.

When a customer installs his own electrical equipment on the No. 12 Milling machine, it is strongly recommended that the operating control prevent feed and pump motors from operating when cutter motor is not running. Feed and pump motors should also be provided with individual stop control.

Lubrication

Lubrication of this machine, with the exception of the cutterhead, requires high quality oil comparable to S.A.E. No. 30. Oil cups should be filled daily, and general oiling of other parts such as feed screws, universal joints, etc. should be done weekly.

CUTTERHEAD: The spindle bearings and spindle drive gears of the cutterhead are lubricated separately. A special "Van Norman Lubricant" is recommended for the bearings which are lubricated through the grease fittings on the head. This lubricant may be purchased from the Van Norman Company.

CAUTION: Do not overgrease. Too much grease will cause overheating of the bearings and possible leakage through the spindle nose.

The spindle gears are lubricated with a heavy oil such as "600 W" or a satisfactory substitute.

Put head in horizontal position, and remove oil filler and oil level plugs, Fig. 6 (Page 6). Pour in oil until overflow just begins. Replace plugs and operate the machine for half a day, then unscrew overflow plug again and drain off any excess oil.

CAUTION: This latter procedure must be followed in order to eliminate possibility of the excess oil working out through the head bearing and spindle.

RAM AND FEED GEAR BOXES: Use a good grade of oil having the following specifications:

A.P.I Gravity 23
Flash, O.C. °F 450
S.U. Viscosity at 210 °F 73
Pour Point, °F 0

Fill gear boxes to the oil line on the sight glass. Approximate capacity of the ram is two quarts and of the feed box, one quart.

To add oil, remove the small covers on the top of the gear boxes. The oil should be changed the first time after the second month of operation and every six months thereafter.

MOTORS: Should be lubricated every three to six months with machine oil in accordance with the individual manufacturer's instructions.

NOTE: Do not overfill any of the oil reservoirs. Overfilling results in unnecessary heating and an overflow of oil along the shafts and through the bearings, causing leakage. Keep oil at lines on sight glasses.

Operation

The machine is now ready for operation, so it would be well for the operator to become familiar with the movements available, both manual and power operated. In general, the machine is oper-

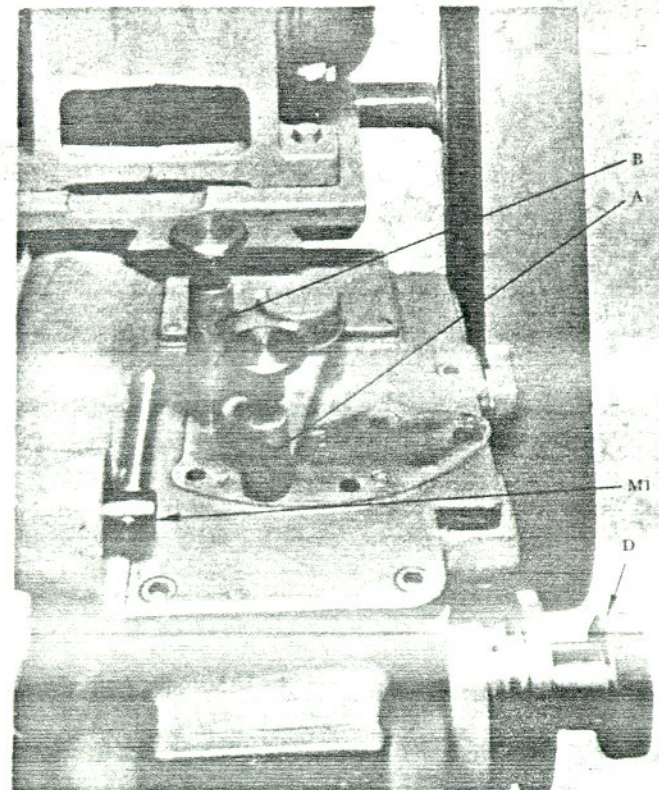

FIG. 5—View Showing Spindle Speed Levers

ated by two motors, one operating the cutter exclusively, and the other the table feed. Each motor has its attendant gearbox for obtaining various speeds. Vertical adjustment of the knee and cross adjustment of the saddle are entirely manual. Table feed may be either power operated or hand operated; when power operated, the length of table travel can be preset with the adjustable stop provided for the purpose. Cutterhead is reversible, electrically.

CAUTION: STOP MOTOR BEFORE SHIFTING GEARS. Do not clash moving gears when changing speeds.

CUTTERHEAD SPINDLE SPEEDS: Various cutter spindle speeds are obtained by positioning levers "A" and "B" (See Fig. 5) on top of ram, in accordance with the table on the etched plate "C" (Fig. 2) on ram. Being sure cutter-spindle is stationary, lift the handle on lever, disengaging the spring tensioned pin from the stop hole beneath, and move until the desired hole is engaged. If the gears do not readily mesh, slightly rotate hand wheel "D" (Fig. 5), and set lever "A" first, then "B", thus engaging the teeth on the gears which may have had their edges on "dead center." To reverse cutter direction, throw reversing switch on starter case.

CUTTERHEAD ADJUSTMENT (See Fig. 6): The cutterhead is adjustable to any angle between

horizontal and vertical, the desired angle being readable on scale "E". Loosen the two binder screws "F" on right side of head using tee wrench provided in tool kit, and also binder nut which is located behind the head between the spindle and the ram, slowly swing head to desired angle, and tighten the three binders. Stops "H" which have been factory set, accurately determine the horizontal and vertical positions. When adjusting head, do not bang the head against these stops, as misalignment might result from the stresses incurred.

RAM ADJUSTMENT (See Fig. 2): The Ram is adjusted forward and backwards on its ways by ram feed screw "I" which extends out from under rear of ram. A removable crank handle is provided with the machine to fit the end of this screw. In order to move ram, it is necessary to loosen binders "J" on right side of column just under the ram ways, and to tighten them after desired position is set.

OVERARM ADJUSTMENT: When heavy horizontal milling is to be done, it is desirable to steady the arbor with the overarm and arbor support. Binders "M-1" (Fig. 5) and "M-1" (Fig. 2) should be loosened, and overarm slid into position, and then binders tightened. Lubricate the center on the arbor support when in use.

KNEE OPERATION (See Fig. 1): The knee is raised and lowered manually by handwheel "N" which operates the vertical screw through a bevel gear. A graduated dial is mounted on the shaft behind the handwheel, marked off in thousandths of an inch. To set the dial, loosen the thumb screw on its hub, rotate it to the desired reading, and tighten the thumbscrew.

The knee is locked in position by knee gib binder "O" on vertical way on left side of the knee. This should be loose when vertical adjustments are being made, as tightness results in wear on the vertical screw.

CROSSFEED OPERATION (See Fig. 1): Crossfeed or cross adjustment of the saddle is obtained by the saddle crossfeed screw and handwheel "P". A graduated dial is provided. Crossfeed binder "Q" is located under saddle on left side, and operates by tightening the saddle gib. Binder should be loose when adjusting the crossfeed to prevent unnecessary strain on the crossfeed screw and nut mechanism.

TABLE FEED (See Figs. 1 and 7): Table feed is provided by table feed screw "R", which may be turned by either handwheel "S-1" or "S-2", or by the power feed. A dial graduated in thousandths

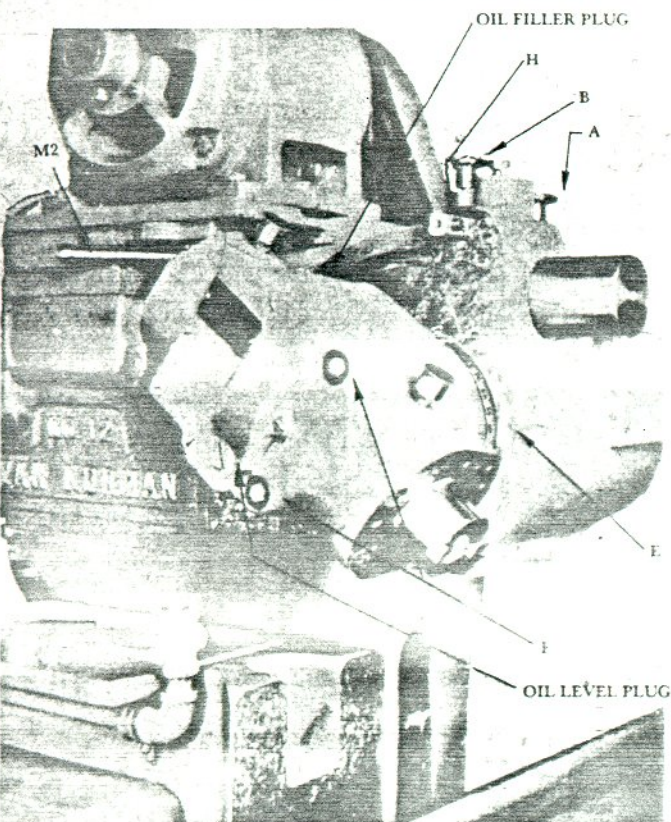

FIG. 6—Cutterhead

of an inch is mounted on screw shaft at left end of table. Binder screw "T" locks table, when desired.

Power feed is obtained from the $\frac{1}{4}$ HP motor mounted on back of column. This motor drives feed gearbox "U" (Fig. 7) through a silent chain drive; the gearbox is coupled to the saddle and table through telescoping shaft and universal joint assembly "V" (Fig. 2).

The positions of levers "W" on top of gearbox "U" determine the feed rate in inches, as indicated on etched plate "X". These levers are operated in the same manner as the ram levers "A" and "B". If gears do not mesh readily due to their

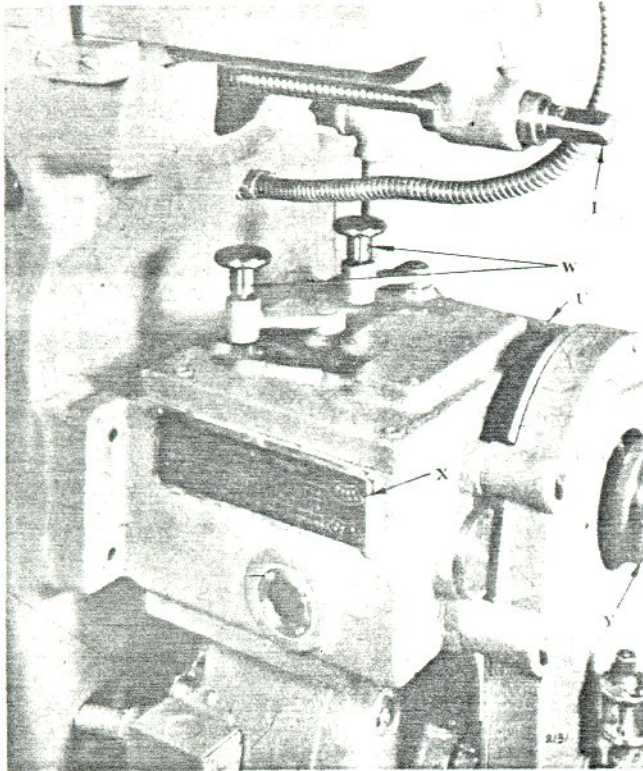

FIG. 7—Table Feed Gear Box

edges being on "dead center," this can be avoided by first setting positions 1 through 4, and then 5 through 7, while turning handwheel "Y" slightly.

Lever "AA" (Fig. 1) on front of saddle throws in the power feed on the table. Moving it to the right should cause the table to travel to the right, and the left to the left. If the reverse is true, interchange two of the power feed wire connections to correct the direction of rotation of feed motor. When lever "AA" is in a vertical position, the power feed is disconnected by a clutch located in the saddle, and adjustments of table may be made by hand even though feed motor is running.

TABLE STOPS (See Fig. 1): Stops "BB" are fixed in position at the factory and should not be touched. They are safety stops provided to prevent the table running out too far and damaging the feed mechanism. Stop "CC" is adjustable, and is used to limit the length of table feed travel. All stops operate by depressing plunger "DD" which in turn forces lever "AA" to the vertical, or neutral position, stopping further table travel.

Gib Adjustments

The table, saddle, knee and ram gibs are properly adjusted when leaving the factory and should not be readjusted unless absolutely necessary.

The table gib is adjusted by means of the screw on its right end, and locked by the stop screw on the left end. To adjust, loosen the stop screw, and adjust in or out with the adjusting screw. When checking adjustment, always reset the stop screw.

The knee, saddle and ram gibs are solidly locked in position, but are adjustable with spreader screws located in the gibs themselves.

The knee spreader screws extend from the knee into and through the knee gib. Locknuts prevent them from shifting. These should be loosened before adjusting, and tightened before each check on the adjustment. All spreader screws should be adjusted an equal amount, a little at a time between checkings.

The saddle gib spreader screws are in the gib itself, and should be adjusted a little at a time, all equally. They are locked by two setscrews in the gib which tend to press the gib away from the saddle, thus applying tension to the screws to prevent their turning.

The ram gib screws in the right side of the column extend upwards into the ram gib. To adjust these, just turn them slightly, all equally.

CHECKING GIB ADJUSTMENTS: Gib adjustments should only be made by those who are acquainted with the operation. In general, all gibs should be tight enough to eliminate all play, but not so tight that there will be a heavy drag on the working parts. Gibs that are too loose will result in inaccurate work. Gibs that are too tight will cause severe wear and strain on the operating mechanisms.

Feed Screw Adjustments

TABLE (See Fig. 8): The Table Screw is adjusted by means of an adjustable nut at the left hand end of the Saddle. To adjust, loosen check nut "A" and adjust nut "B" in either direction to remove backlash. After completing adjustment tighten check nut "A".

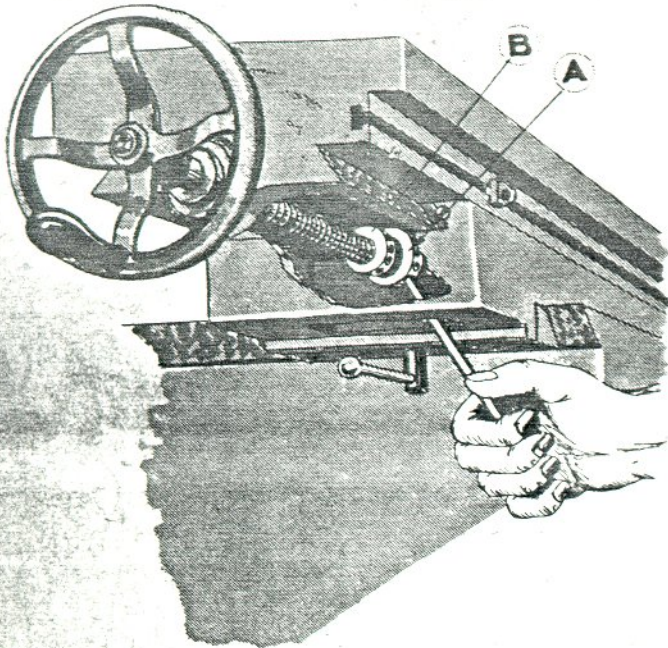

FIG. 8—Table

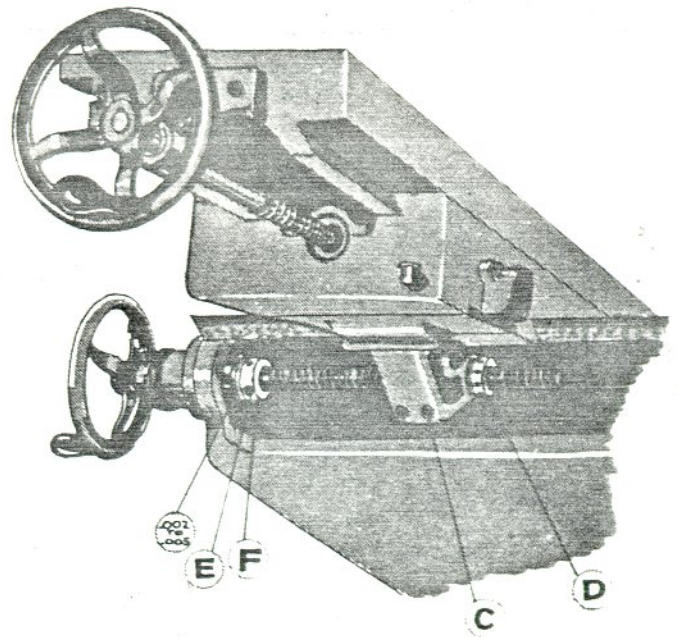

FIG. 9—Saddle

SADDLE (See Fig. 9): The Cross Feed Screw is adjusted by means of an adjustable nut at the right hand end of the Saddle. To adjust, loosen set screw "C" and adjust nut "D" in either direction to remove backlash. After completing adjustment tighten set screw "C". To remove end play in screw loosen set screw "E" and adjust nut "F" until end play is from .002 to .005. After completing adjustment tighten set screw "E".

PARTS LIST

and Instructions for Ordering Replacement Parts for

MODEL No. 12 VAN NORMAN RAM TYPE MILLING MACHINE

The following pages contain full information to enable the users of the No. 12 Ram Type Milling Machines to order replacement parts with a minimum of effort.

We have endeavored to simplify the identification and selection of such parts through the use of drawings of parts for each major unit of the machine. If certain small screws and other miscellaneous parts not shown are required, they should be obtained from a local mill supply house or hardware store.

It is important that in any correspondence with the factory regarding parts, the model and serial numbers of machines should be given. The serial number is stamped on the front face of the column near the top of all Van Norman Milling Machines. It is also advisable to include, when possible, the date and number of your original purchase order of the machine.

INDEX

	PAGE		PAGE
Column Base Coolant	9	Ram	12
Feed Box	10	Cutter Head	13
Knee, Saddle and Table	11		

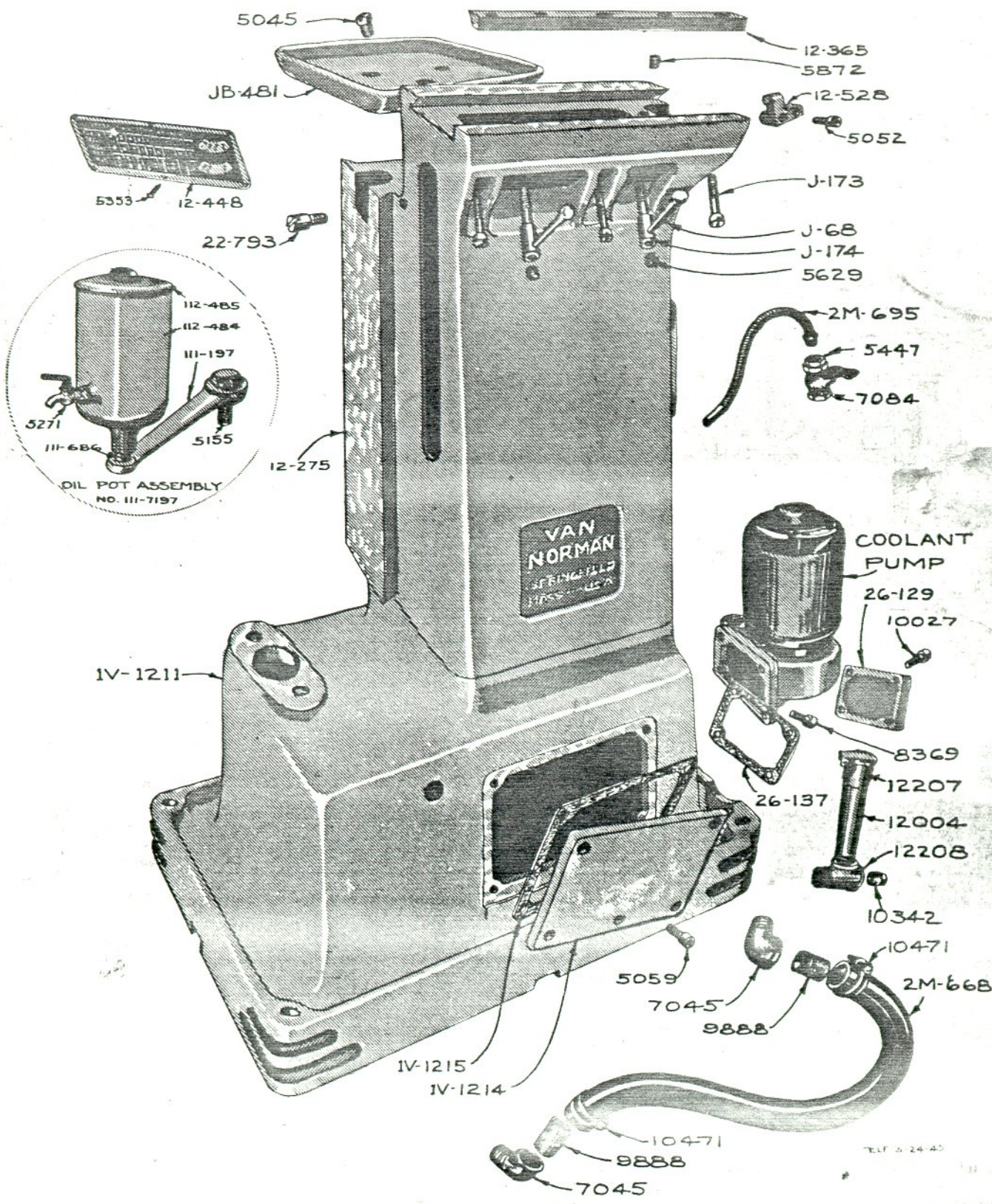

No. 12 MILLING MACHINE COLUMN-BASE-COOLANT

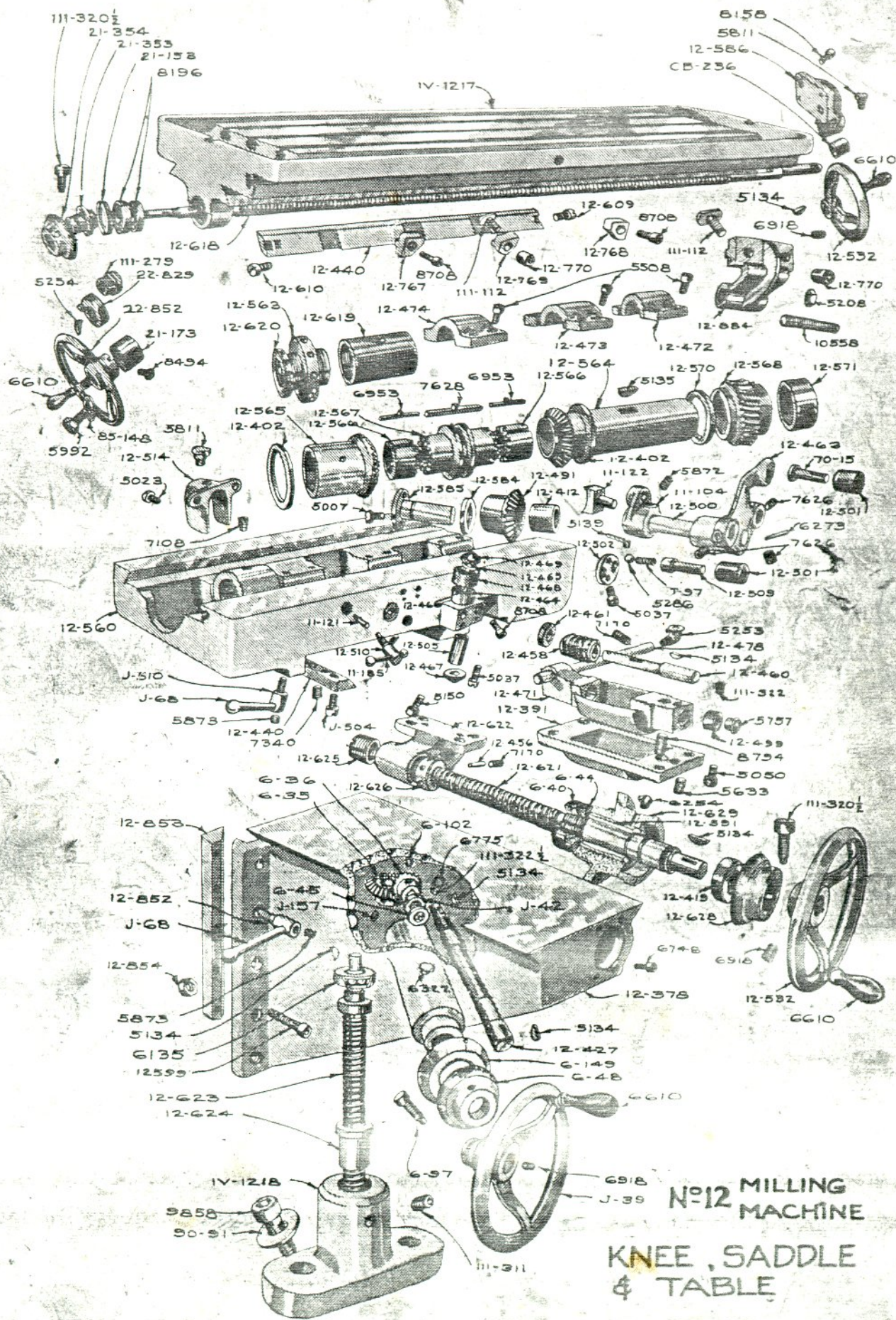

No. 12 MILLING
 MACHINE
 KNEE, SADDLE
 & TABLE

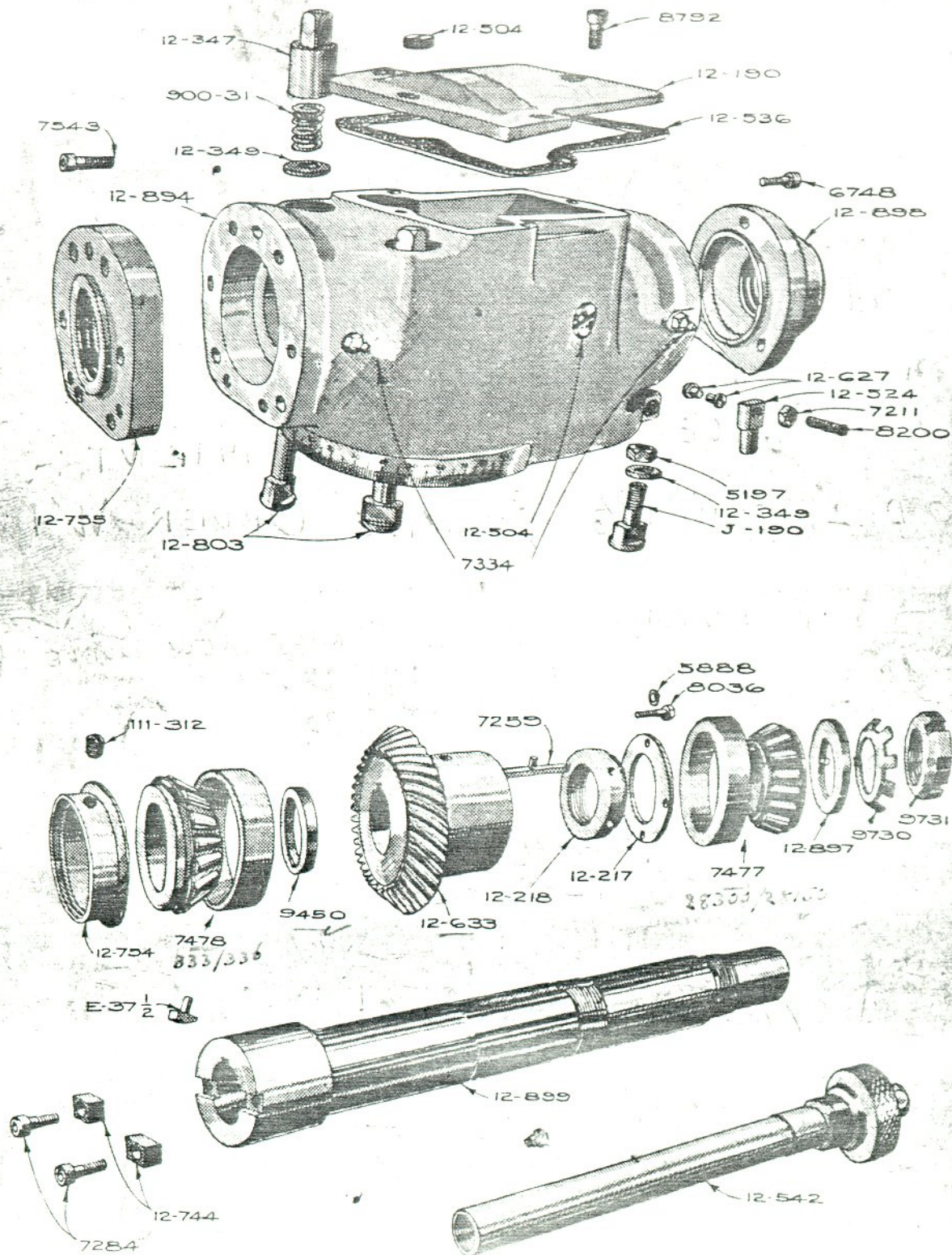

RLF 11-74

№12 MILLING MACHINE — CUTTER HEAD

NOTES

Bel Fenner V $\frac{5}{8}$ x 40" 3B8.

Best time for A31 one set +
Work head A25.

THRUST RACE FOR HEAD ATTACHMENT :-
O.D. 2" I.D. $1\frac{3}{8}$ $\frac{3}{8}$ WIDE ORDER W $1\frac{3}{8}$.

RANSOME MARLES, SINGLE ROW DOUBLE PURPOSE

BALL BEARING NO L T T 30 = 30-62-16. = TOP

TIMKEN TAPER ROLLER BEARING NO 30207/35, 72, 100

CUP EXTRA SIZE NO 16284 (2.8440.)

16.D.P. 20° PA.

SMALL HEAD GEARS