

Milwaukee

MILLING MACHINES

Bulletin No. HC13

MODEL NO. 2H

Plain, Universal and Vertical

INSTRUCTION BOOK



KEARNEY & TRECKER
CORPORATION

Milwaukee

**M A C H I N E
T O O L S**

MODEL 2H

PLAIN, UNIVERSAL AND VERTICAL
MILWAUKEE MILLING MACHINES

K E A R N E Y & T R E C K E R
Corporation

OPERATION
LUBRICATION & ADJUSTMENT

UNCRATING

Carefully remove protective crating and skids so the machine and its parts are not marred, scratched or impaired. In the event of damage in transit, communicate at once with our representative and the transportation company making delivery.

SHORTAGES

Check shipment carefully against the itemized packing list which is included in the parts box. When two or more boxes are necessary the parts list will be found in the one marked, "PACKING LIST INSIDE THIS BOX." In case of shortages, report them immediately to the representative from whom the machine was purchased, indicating parts not received and checked on the packing list.

HOISTING

DO NOT USE CHAIN OR CABLE! BE CERTAIN ROPE IS OF SUFFICIENT STRENGTH (1-1/2" manila standard or equal). Exercise extreme care when hoisting machine, balancing on rope before raising. When lifting vertical machines, thoroughly protect all contact by blocking out rope, soft wood, burlap or equivalent.

-- HORIZONTAL MACHINES --

Place a spliced rope in U fashion under the rear end of overarms, extending it doubled through the crane hook, then continuing it downward to loop around the extended front ends of overarms.

NOTE: Please refer to the lifting instructions tag accompanying each machine.

-- VERTICAL MACHINES --

Place a spliced rope under neck of column and attach to crane hook. Before raising make certain the rope clears the sliding head of the machine.

NOTE: Please refer to the lifting instructions tag accompanying each machine.

PLACING ON
SOLID
FOUNDATION

Milwaukee Milling Machines are extremely rigid and accurate. The column is cast in one piece and machined on the bottom to insure level installation when resting on a flat surface. Where a concrete foundation is used, it is advisable to apply grouting to eliminate any unevenness, thus providing a solid foundation at all points. When erecting machine on an upper floor, select where possible, a position over a girder, near a wall or some other suitable place where building vibration is at a minimum.

LEVELING
MACHINES

The milling machine's work table is the index to proper leveling. Center the saddle on the knee and table to saddle. Prepare the machine for accurate installation by crosswise and lengthwise level readings of the table with the machine supported on taper wedges on the four corners of base. After obtaining a level position insert additional wedges around entire base. Use heavy duty lag screws to secure the machine firmly to its foundation. Long and satisfactory service will repay the time taken in properly setting the machine.

CLEANING

Thoroughly clean slush from machine with gasoline or kerosene. Do not move any part of the machine until all exposed surfaces have been cleaned and oiled. Then by hand move the table, saddle and knee to the extreme stop in one direction. Clean and lubricate the exposed ways, screws, etc., repeating the process after sliding each unit to the other extreme limit stops.

-- HORIZONTAL MACHINES --

Clean and lubricate exposed ends of overarms then un-clamp and slide arms forward and back to full length. Clean exposed centers and oil these surfaces to permit free movement and to eliminate corrosion inside the column bores.

-- VERTICAL MACHINES --

Release sliding head clamp lever (No. 63), and the three lock nuts with washers on the upper left, and upper and lower right side of head (No. 60 and 76). Clean and lubricate the exposed portions of the sliding head ways; then by hand, raise and lower the head in both directions, wiping and oiling sliding surfaces after each movement.

To clean screws (No. 68) regulating the Four Position Micrometer Stop on Vertical machines, remove lower locknuts (No. 70), and lift screws out of indexing cylinder.

SPEED OF SHEAVE
AND DIRECTION
OF ROTATION

The correct R.P.M. with arrow indicating the direction of rotation is clearly shown on the face of the large Vee-belt pulley sheave. It is essential that the R.P.M. and proper direction of rotation be noted and maintained because the machine cannot be automatically lubricated and operated successfully when the motor is running in the wrong direction.

SETTING
MOTOR

The motor cooling fan is pressed onto the hub of the motor sheave. Place this sheave on the armature shaft with fan facing the motor. Then place motor on its base plate in column. To properly align the motor sheave in relation with the main drive pulley the distance from the center of outer grooves to the side faces of both sheaves are identical. Allow for end play of the armature shaft, and use a straight edge against both sheaves to align them accurately. Having thus ascertained the proper position of the motor, mark out its location on the base plate to drill and tap holes for mounting motor.

NOTE: V-Belts must have accurate vertical and horizontal alignment to insure lasting wear.

PLACING AND
ADJUSTING
V-BELTS

To permit movement of motor plate, release lock screw located at right of motor sheave. Raise the plate by adjusting screw located just inside the motor door (No. 14) on left side of column. Mount belts one at a time, alternating from pulley to motor sheave grooves until all have been placed. To adjust belts to proper driving tension, lower motor plate with adjusting screws located to the right and left rear of plate and secure the adjusting screws with lock nuts furnished.

NOTE: To avoid unnecessary pressure on the motor bearing, the V-belt tension should be less than required for a flat leather belt drive.

LUBRICATION

Do not operate this machine until it has been properly lubricated. (Refer to numbers on illustrations in the back of this booklet.)

COLUMN
LUBRICATION

A central lubricant reservoir directly above the motor compartment lubricates the entire mechanism in the column, including the speed control and pulley drive units. Fill reservoir through the spring cap opening located at center of rear column wall. Oil capacity is indicated by the high line sight gauge (No. 9) above the left motor compartment door. Use a good grade of machine oil, (Viscosity 300 to 325 Saybolt at 100 degrees). Approximately 4 gallons are required. Sight oil flow gauges located on left side of column are provided. (No. 4 and No. 66).

KNEE
LUBRICATION

Fill lubricant reservoir in knee through filler cap opening located above gauge (No. 18). Use a good grade machine oil (Viscosity 300 to 325, Saybolt 100 degrees).

Knee lubricant gauge (No. 18) is a combination oil level and flow gauge. It indicates the height of oil level and shows whether or not the oil is circulating. A gear driven pump supplies a large volume of oil to all revolving parts in the knee, and also lubricates the column ways and the vertical elevating screw. All running parts in the knee are flooded with oil immediately when motor of machine is started in operation.

NOTE: Inspect frequently in maintaining oil level to correspond with line on lubricant gauge (No. 18). Reservoir capacity 1 to 1-1/2 gallons.

(Lubrication of Sliding Head)

VERTICAL
MACHINES

Use the same high grade machine oil (Viscosity 300 to 325 Saybolt at 100°). Fill head reservoir through spring cap opening to arrow line on combination sight level and drip gauge (No. 74). The head is equipped with a geared pump which forces the oil above the upper bearing to lubricate the driving gears center and lower bearings - including the ways and elevating screw. Reservoir capacity one pint to gauge line. To prevent overflow and leak at spindle end do not fill above line or while spindle is rotating.

CLEANING
LUBRICANT
RESERVOIRS

The column, knee and sliding head reservoirs should be drained and filled with fresh oil approximately every four months. Column drain plug (No. 55) is exposed when opening motor safety door (No. 56); knee drain plug at rear underside of knee (No. 59); and vertical head drain plug directly under filler cap (No. 74).

After draining oil, reservoirs should be filled with kerosene. With machine in operation, for five minutes, flush pumps, piping, and all mechanism. Then remove kerosene and fill reservoirs with fresh oil. THE NECESSITY FOR PERIODICALLY FLUSHING OUT THE OLD LUBRICANT FROM COLUMN, KNEE AND HEAD CANNOT BE OVEREMPHASIZED.

SADDLE
LUBRICATION

Fill saddle lubricant reservoir (No. 13) daily through pipe plug opening. Copper tube-enclosed wicks, which provide a continual flow of filtered oil from this pocket, lead lubricant to table drive mechanism, table feed screw and nut, crossfeed screw and nut, table drive shaft and the sliding way bearing surfaces of the knee, saddle and machine table.

TABLE THRUST
BEARING
LUBRICATION

Fill lubricant cups located at each end of table daily to properly lubricate bearings at ends of table feed screw.

LUBRICATION
OF OVERARMS

Overarms should be kept clean and lubricated with a thin film of oil for ease of movement and to prevent corrosion inside of the column bore walls. Cleaning and oiling overarms also will prevent marring when applying arbor supports.

ARBOR SUPPORT
LUBRICATION

Arbor supports (No. 35) are equipped with lubricant reservoirs and sight gauges which provide automatic lubrication between the arbor support bushing (No. 36) and arbor bearing.

MOTOR
LUBRICATION

Have motor bearing lubricant cups filled at all times. Both motor bearings are lubricated through spring cap openings located inside of motor safety door (No. 14).

BALL BEARING
MOTOR LUBRICATION

About every six months supply grease lubricant.

MOTOR COOLING

Fresh air is constantly circulated through motor compartment by a safety fan mounted on armature shaft directly behind motor sheave. A constant flow of air is circulated through motor compartment by means of louvers cast into motor safety doors (No. 14) and (No. 56).

COOLANT
RESERVOIR

The coolant reservoir is located in the base of the machine, to fill reservoir, remove the screen cover plates (No. 20) at forward top of base, pour liquid at this point until level meets screens.

COOLANT RESERVOIR CAPACITY - Six Gallons.

CLEANING CUTTER
COOLANT PASSAGES
AND RESERVOIR

The rear longitudinal pocket in the milling machine table is provided with a fine mesh screen to prevent chips entering and clogging the coolant return channels. This screen can readily be removed in order that the table pocket channel can be cleaned of the fine grit deposited by the coolant as it returns to the reservoir. If this fine grit is not removed it will accumulate into a caked mass and prevent the return of the coolant from the table to the reservoir.

To clean the coolant reservoir in the base of machine, remove the screens under the circular plates (No. 20). The coolant and any accumulation of sludge can be removed through these two openings as the telescopic tube is purposely located near one of these openings to facilitate cleaning any grit that deposits at this point. A screwed plate at rear base of column can also be removed to clean out channel to pump.

CUTTER COOLANT
PUMP

Cutter coolant pump is of the geared type. It is located at machine base (No. 58) inside of sheave and belt cover door. When milling cast iron or other material not requiring cutter coolant, the pump should be disengaged by disconnecting pump drive clutch (No. 57) located at the bottom of vertical splined shaft.

CUTTER COOLANT
FLOW

Horizontal machines - The amount of cutter coolant flow is regulated at both outlet nozzles (No. 50) which can be swiveled to properly distribute coolant to cutters of all diameters. Each nozzle has two swivel joints and the outlet unit is mounted on a bracket which can be clamped to either overarm by means of a split circular clamp (No. 49). (Coolant volume 1-1/2 gal. per min.)

Vertical Machines - The amount of cutter coolant flow is regulated through a single coolant nozzle, mounted on a universal bracket to stud on head. (Volume one gallon per minute). (No. 79-80)

The stopping of the machine spindle stops the coolant flow and likewise when the spindle rotates, the coolant flow starts automatically when the coolant pump driving clutch mounted on feed spline shaft (No. 57) is engaged.

When continuous coolant flow is desired, remove the four screws and reverse pump cover (No. 58) and place pump drive clutch to rapid traverse vertical spline drive shaft. With machine motor in operation and machine spindle stopped, a cleaning hose can be tapped into coolant line at joint of flexible tube for washing grit and chips from fixtures, vises and machine table or regular coolant valves can be operated as desired.

NOTE: To reverse coolant pump cover - lift cover directly upward to release dowel pins, clean cover and pump faces and reseal to prevent leak. When removing the coolant pump drive clutch from vertical shaft, wrap entire clutch with a wiping rag to catch detent spring and balls. When placing clutch on end of R.T. vertical shaft, place spring into hole through shaft, compress spring with ball at both ends and slip clutch into position.

STARTING LEVER

When power is applied, the clutch is engaged by means of the starting lever (No. 1) on Horizontal and (No. 62) on vertical machines to supply power

to all machine units.

ON HORIZONTAL MACHINES - The starting lever can be placed in any position through 300 degrees in a horizontal plane, merely by raising the lever at shaft hub about 1" when it can be swiveled and reset as desired.

ON VERTICAL MACHINES - The starting lever can be placed in any position conveniently within reach of operator. This is accomplished by removing lever from serrated shaft and reseating.

NOTE: When the main drive clutch is disengaged, a cone type brake, located inside the column is automatically engaged. Both clutch and brake are controlled by in and out positions of starting lever movement (No. 1) Horizontal and (No. 62) Vertical machines.

SPINDLE SPEED SETTING

It is important that spindle speed changes be made only when the starting lever (No. 1 or 62) is disengaged. The three spindle speed change gear levers (No. 5), (No. 6), and (No. 7),

located on the left side of column on horizontal machines, (Speed range lever (No. 61) is mounted to sliding head on vertical machines). All three levers are used for the selection of any of the sixteen speed changes. When the levers (No. 5 - 61) are set in center position, all gear contacts with the spindle are disengaged, permitting ease of spindle rotation by hand for accurate cutter setup, whenever this method of accurate cutter setting is desired.

The motor should be running when making spindle speed changes. To position either lever engage starting lever slightly "on" and "off" to revolve speed train slowly in moving speed levers without clashing of gears.

SPINDLE REVERSE

The spindle reverse is of the built-in mechanical type and is easily operated by the plunger type knob (No. 8) located at left side of column. The reversing of spindle is easily accomplished. Rotation of spindle operating in either direction has no effect on the direction of the feed or lever controls.

CAUTION: Spindle reverse should only be made with starting lever (No. 1) or (No. 62) disengaged and speed range lever (No. 5) or (No. 61) placed in slow position. Then jog the starting lever in and out with right hand and apply pressure to push or pull reverse lever engagement with left hand.

REMOVING ARBORS

With speed range lever (No. 5) or (No. 61) set in "SLOW" position, release adjusting nut on draw-in rod several threads. Tap outer nut face of draw-in bolt lightly with wrench to release arbor from spindle taper. Rotate draw-in rod to disengage threaded end from tapered end of arbor to remove shank from spindle taper.

NOTE: Due to the standardized steep angle non-sticking taper of spindle, (3-1/2" per foot) it is always necessary to hold the arbor firmly in the taper hole in the spindle when engaging or disengaging draw-in rod.

FEED CHANGES

Desired feed is obtainable by with-drawing feed change lever handle (No. 19) and revolving lever in either direction until desired feed corresponds with arrow. For ease of operation feed changes should be made with spindle running. When milling cuts are light, feed changes can be made without disengaging either the table, cross or vertical feed levers. The feed drive is of the sliding gear transmission type and mounted on anti-friction bearings in the knee.

All feed gears are heat-treated and hardened, mounted on splined shafts and run in oil which is supplied by a geared pump attached to feed and rapid traverse unit at right side of knee. Like the column lubricating pump, when machine motor is running the knee lubricating pump is operating and entirely independent of the main drive clutch controlled by the starting lever. With this construction the oil is always in circulation and it is not necessary to engage the main drive clutch or any of the feed levers to obtain the proper lubrication for all mechanism in knee as well as units attached. The column face and sliding rear face of knee are automatically lubricated including the vertical screw from this centralized gear pump.

FEED MOVEMENT

When engaging the longitudinal, the cross, and vertical feed levers for movement of either the table, saddle or knee it is desirable to have the spindle rotating. The

longitudinal movement of the table is controlled by feed engaging lever (No. 29). The cross feed movement is controlled by feed engaging lever (No. 30), and the vertical feed movement is controlled by feed engaging lever (No. 33). To engage the cross feed to saddle or vertical feed of knee, withdraw handwheel or crank, then engage cross or vertical control levers for cross or vertical feed directional movements as indicated at front of knee. The handcrank (No. 12) on left hand end of tablescrew is spring actuated and this crank automatically disengages when hand pressure is released.

SLIDING HEAD

The handwheel (No. 73) of sliding head on vertical machines is interlocked with the directional feed lever which automatically disengages when power feed is engaged and re-engages when power feed lever (No. 77) is tripped into neutral.

NOTE: The power rapid traverse lever (No. 45) controls the sliding head fast movement and also operates the table, saddle and knee movements at fast rate. With the engagement of either feed lever the rapid movement to table, saddle, knee or head is instantaneous by merely raising the rapid traverse lever (No. 45).

The power rapid traverse drive is entirely independent of the feed drive and is continually in operation when the motor is running in obtaining the fast rate of movement to the table, saddle, knee or head with spindle of machine either running or stopped.

TABLE FEED LEVER IS RE-ENGAGING TYPE

The table feed engaging lever (No. 29) is directional and is so constructed that by raising the handle it is possible to escape a preset trip and continue past it as the operator desires. Thus, the workpiece can be rapid traversed up close to the cutter and table movement stopped instantly by tripping table lever to neutral with adjustable preset trip dog. The operator can then raise the feed lever and re-engage the feed into the cut. This exclusive feature facilitates a wider and more efficient use of power rapid traverse with absolute safety to machine, cutter and workpiece.

After the cut is finished and it is desired to return the table to the starting position then it is only necessary for the operator to reverse the feed lever which will then automatically pass the set position of the feed trip dog and bring the table to the original position for unloading and loading a duplicate workpiece. Tripping to a starting position is accomplished by another trip dog which is adjustable and can be placed at will to stop the table travel at any point in relation to the distance from the revolving cutter to permit changing of workpieces in perfect safety without stopping the spindle. The tilting table feed engagement lever offers a skip stop arrangement to the table feed and rapid traverse movements that is entirely under the control of the operator at all times. This re-engaging type of table feed lever is the most convenient feed lever ever placed on a milling machine, and it is well to study the possibilities of this feature so as to get the maximum productive results from the machine.

DIRECTIONAL
FEED LEVERS

On all milling machines, regardless of age or make, the following hand movements have always been standard; turn the table handcrank (No. 12) to the right and table will move from left to right; revolve cross handwheel (No. 31) to the right and saddle moves "IN"; turn the elevating crank (No. 32) to the right and knee moves "UP". Feed levers (No. 30) and (No. 33) have identical directional movements. Engage lever (No. 29) to the left and table feeds to the left; move lever (No. 30) to the left and saddle travels "OUT"; move lever (No. 33) to the left and knee moves "DOWN". On vertical machines, the sliding head moves either up or down by directional engagement of power feed lever (No. 77).

SAFETY TYPE
HANDWHEELS
AND CRANKS

All handwheels and cranks are provided with means for safety and efficiency. They are interlocked, positive and foolproof. Handcranks and handwheels cannot be left attached or engaged, and accidentally revolve when power is engaged. The operator is always completely protected regardless of location in operating machine.

ADJUSTABLE AND
POSITIVE SAFETY
LIMIT STOPS

In order that the power longitudinal, power cross and power vertical feeds can be disengaged automatically, adjustable trip dogs are provided, four on the table, two on the saddle, two on the knee and two on the sliding head when vertical machine is equipped with power feed to the head. These adjustable trip dogs can be set so that the power feed will be tripped out at any desired point. To trip the power feeds or rapid traverse movements before reaching the end of travel, fixed limit stops are provided on the table, saddle and knee. On vertical machines equipped with sliding head power feed, two limit pins are provided to serve as bumpers for the adjustable trip dogs.

NOTE: The adjustable trip dogs should never be removed from side of vertical head slide. When both trip dogs contact limit pins the maximum vertical movement of head is obtained. Removing adjustable trip dogs for greater head travel will result in damage to head.

On vertical machines with power feed to sliding head an additional feed or rapid traverse trip, regardless of trip dogs, is affected when micrometer rod contacts tripping plate to precision stop button. This button will depress about 1/4" before feed trip is affected.

CLAMPING TABLE,
SADDLE AND KNEE

When milling with table movement, it is advisable to clamp levers (No. 15) and (No. 17) locking knee to column and saddle to knee to add rigidity to these members and provide for heavier cuts with greater feeds without vibration.

The table locking lever (No. 11) is located at front of saddle. The saddle clamping lever (No. 15) is located at left under side of saddle, and should always be clamped when cross movement is not required. The knee clamping lever (No. 17) is located at center left of knee, and should be drawn upward to clamp the knee to column solidly when vertical movement is not required.

SLIDING HEAD
CLAMPS

On vertical machines - Clamping lever (No. 63) is intended for clamping head for light cuts or duplicate step milling operation permitting speedy release of clamp for resetting head to various heights. For large diameter cutters on heavy milling, the head should be locked solid at four equal points. Lock nuts are provided for this purpose, one on left above clamp lever, and two on right side of head. (No. 60 - 76).

INTERLOCKING
LEVERS

The cross handwheel (No. 31) and vertical handcrank (No. 32) are interlocking and as an added safety to machine and operator both crank and wheel can be placed in a neutral position with knee or saddle clamped; interference rings are cast integral in the cross and vertical feed control levers and cannot be engaged accidentally or otherwise when handwheel or crank are positioned in neutral.

These same interference rings obstruct the engagement of power feed when hand feed is in use and in like manner they obstruct the engagement of hand feed when power feeds are desired.

Both handwheel and handcrank have three positions and detent controlled - pull handwheel or crank all the way out and power feed can be accomplished, push either half way in for the neutral position, and when all the way in hand movements of saddle and knee can be made.

CAUTION: Be sure to release respective clamps before attempting to operate power longitudinal, cross or vertical movements, as neglect in doing this may result in damage to the ways.

FEED SAFETY
SLIP CLUTCH

Built into the feed drive mechanism located in the knee, and provided to protect the feed gear train from breakage when the feed is beyond the capacity of the machine - or the table, saddle, knee or head movement has met with an obstruction. On overloads this safety clutch automatically disengages and a series of clicks can be heard informing the operator to disengage the starting lever. After corrections are affected or feeds reduced the safety clutch is again ready to perform in transmitting the power through the feed train. This clutch is properly adjusted at the factory to 100% overload and any further adjustment to clutch has been purposely eliminated.

RAPID TRAVERSE
SAFETY CLUTCH

This is mounted into the Rapid Traverse drive gear train located in drive unit at right side of column. This safety clutch prevents damage to the drive gear mechanism in supplying the fast rate of movement to the table, saddle, knee or head.

SAFETY
CLUTCHES

The function of safety clutches are to protect the mechanism of a machine. They are designed to slip automatically when cutting pressures are excessive or when the machine runs into obstructions. At the same time, these

clutches must be strong enough to operate the machine under normal loads and working conditions.

It must be realized that where the shock to a safety clutch is hammerlike and abrupt that damage to the screws and nuts of the machine will often result. On the other hand, if the shock is gradual, such as when the obstruction is of a somewhat resilient nature - as a piece of wood or pile of chips - the safety clutch will generally function without any damage to the machine.

The adjustable trip dogs are another insurance against damage; when properly set they will prevent the cutter from contacting the work or fixture at the rapid traverse rate of travel - and thus prevent all avoidable accidents.

ADJUSTING THE
MAIN DRIVE
CLUTCH

The main drive clutch (No. 53) when engaged drives the spindle speed and power feed movements. It is built in the center of the large drive pulley located inside motor safety door (No. 56).

This clutch is of the single plate dry disc type, used for years and proven as superior by the automotive industry. By opening the motor door (No. 56) the clutch becomes accessible and adjustment is made without the use of any tools. To adjust or tighten this clutch, pull out the spring plunger lock pin (No. 53) which is located between two of the clutch fingers, and turn the clutch finger ring to the right for taking up clutch, or to the left for loosening. In making this adjustment take up one notch at a time and then check adjustment with the starting lever (No. 1 - 62). When full engagement of starting lever can be made in the ordinary way, without undue pressure in permitting the clutch cone in contacting fingers to compress the drive plate, for normal machine operation then clutch is properly adjusted.

CAUTION: Do not set clutch too tight - a great amount of pressure in engaging the starting lever places a tremendous strain on the clutch fingers and may result in breakage.

ADJUSTING THE
POWER RAPID
TRAVERSE DRIVE
CLUTCH

This clutch is of the multiple disc type and is located in the rapid traverse drive bracket on the right hand side of knee. It is controlled by lever (No. 45) located at right front of knee. This clutch is accessible for adjustment after removal of plate marked "remove to adjust clutch" (No. 46). The takeup of this clutch is similar to the adjustment of the main drive friction clutch. To adjust, pull out the spring plunger lock pin and turn the clutch finger ring to the right for proper driving tension.

Correct adjustment to the rapid traverse clutch is determined by instant upward movement of knee when raising the rapid traverse clutch lever (No. 45). When releasing the rapid traverse lever to feed movement, the knee should not float or bind. If floating or binding takes place, proper adjustment to knee gib is necessary.

NOTE: Always engage rapid traverse clutch gently as a safety precaution against interference when using this fast rate of travel. Undue wear to clutch mechanism is the result of jerking or applying a great amount of pressure in engagement of rapid traverse lever (No. 45).

ADJUSTMENT OF
SPINDLE BEARINGS

Spindles are properly adjusted at the factory and should run for a long period without further attention. However, if it ever becomes necessary to adjust the spindle, the speed range lever (No. 5) or (No. 61) should be placed in neutral allowing spindle to be turned freely by hand.

LOCATION OF SPINDLE
ADJUSTING NUT

The spindle adjusting collar nut is at the rear of center spindle bearing on Horizontal Machines and at top of center bearing on Vertical Machines.

On Horizontal Machines, remove the breather plate (No. 51) and the adjusting nut becomes accessible.

On Vertical Machines, remove head cover (No. 64) to expose the spindle bearing adjusting nut.

On either type machine, loosen the two headless set screws in the collar nut. Tap lightly at sides of set screws to release the bronze shoes underneath the locking screws which contact threads. Place rod in hole of adjusting nut and hold face of spindle firmly, then turn adjusting nut to the right to take up on spindle. While taking up on adjustment nut, tap each end of spindle lightly with a lead hammer, to remove all possible looseness in the collar and spindle bearings. Great care should be exercised not to adjust the spindle too tightly. Proper adjustment is determined by revolving the spindle by hand.

When adjusting the spindle with an indicator, permit about .0003" end play. A spindle properly adjusted will produce fine finishes on heavy milling with large diameter cutters, and will still be free enough to run continuously at the higher speeds without excessive heating and undue wear.

BREATHER PLATES

Breather plates are provided on knee (No. 16) and column (No. 51) to prevent condensation on the inside of these members.

ADJUSTMENT OF FOUR
POSITION MICROMETER
STOP

Vertical Machines - For step milling or blind boring on machines equipped with power feed to head and four position micrometer stop, the four long screws (No. 68) can be set at various heights by adjustment of micrometer nuts (No. 70). Stop screws (No. 68) pass through revolving cylinder so that one pull of ratchet handle (No. 69) revolves

this unit one quarter turn in bringing the next stop screw into operating position. Stop screws (No. 68) are adjusted to proper heights either by measurement, trial or gauge. With starting lever (No. 62) and feed lever (No. 77) engaged, the head can be raised or lowered rapidly, by engaging the power rapid traverse lever (No. 45) to the approximate height desired. When the head movement is tripped out automatically by contact of stop screw (No. 68) to dial indicator arm (No. 71), the handwheel (No. 73) automatically disengages when feed lever (No. 77) is in neutral. The operator now turns the handwheel slightly, lowering the sliding head until dial indicator (No. 72) registers at zero. When cut is completed for the first step, the feed lever, (No. 77) is raised and the rapid traverse lever (No. 45) engaged to raise the head to a position which allows the operator to pull the ratchet handle (No. 69) which draws the next stop screw into operating position for the next stop cut, etc. Upward feed or rapid traverse movement of the sliding head is tripped with the lower adjustable trip dog. Downward feed or rapid traverse movement of the sliding head can be tripped out with either the upper adjustable trip dog or one of the micrometer stop screws (No. 68). Adjustable trip dogs can be set at any position within the limit stop range to trip the feed or rapid traverse movement when machine is not equipped with micrometer stop. The micrometer dial can be revolved to permit adjustment for tripping of head movement from .010" to .030" ahead of zero line on indicator allowing for handwheel adjustment in setting pointer accurately to zero.

ADJUSTMENT OF TABLE SCREW THRUST BEARINGS

The table screw is mounted in brackets located at each end of the table; the bearing in the left hand bracket is of the radial load type while the right hand bracket is provided with two opposed anti-friction bearings to eliminate lash and permit takeup. Removing the cover from right end of table screw exposes the adjusting collar nut. This table bearing adjustment should be made whenever necessary to insure smooth travel to table movement.

ADJUSTMENT OF CROSS FEED SCREW BEARINGS

To adjust the bearings on the cross feed screw, remove the handwheel, (No. 31) power feed lever (No. 30) and graduated dial. An adjusting nut and serrated lock washer are then exposed. Withdraw the serrated lock washer about halfway forward and turn the bearing half of adjusting nut underneath by revolving the washer to the right to make the necessary adjustment to taper roller bearings. Insert the lock washer over both halves of nut after correct adjustment has been made.

VERTICAL SCREW

No provision is made or necessary for the elevating feed screw adjustment. This unit is properly adjusted at the factory and requires no further attention. The weight of knee prevents lash between screw, nut and driving members when accurate desired setting of knee is accomplished to the right with hand crank movement.

VERTICAL SCREW
TO HEAD

Vertical Machines - It is not necessary to make adjustment to the elevating screw operating the vertical movements to head. The weight of head prevents lash between screw, nut and driving members.

ADJUSTMENT OF
TABLE GIB

The table is provided with a full length taper gib located at front dovetail of saddle and has an adjusting screw at both ends of gib. To take up gib, loosen screw at small end of gib 1/8 turn and bring up screw at large end the same amount, backing up the screw at the large end a least bit to make certain a bow has not been placed in gib. Repeat until a very slight "drag" is felt when moving the table full distance by hand.

ADJUSTMENT OF
SADDLE GIB

The left side dovetail of saddle is provided with a full length taper gib with adjusting screws at both ends. To make adjustment, loosen screw at small end of gib 1/8 turn and bring up screw at large end the same amount, backing up on large end screw the least bit in being certain a bow has not been placed in gib. Repeat until a very slight "drag" is felt when operating the saddle by hand.

ADJUSTMENT OF
KNEE GIB

The knee is provided with a full length taper gib, located at left side of knee. The gib has an adjusting screw at both top and bottom ends. To make adjustment loosen screw at small end 1/8 turn and bring up screw at large end the same amount. Repeat this adjustment until the knee moves freely up and down without jumping. Smoothness of knee movement can be determined by placing the hand on top of gib where it makes contact with the column dovetail.

ADJUSTMENT OF
HEAD GIB

The sliding head on vertical machines is provided with a full length taper gib located at left side of head. To take up gib, loosen bottom screw at small end 1/8 turn and bring up screw at top or large end, the same amount. Repeat this adjustment until the head moves freely up and down without binding or jumping.

NOTE: Gib adjustments to the table, saddle, knee or vertical head are of vital importance in maintaining machine accuracy - loose gibs cause chatter, vibration and poor finishes to work as well as undue wear to machine ways. All gibs should be gone over quite frequently and properly adjusted whenever necessary.

ADJUSTMENT OF
KNEE CLAMP

Knee clamp lever (No. 17) is for the purpose of securely clamping the knee to the machine column. To adjust the knee clamp lever, loosen the lock screw at hub of lever and remove clamp handle from serrated shaft. Handle and shaft are serrated permitting any desired adjustment.

ADJUSTMENT OF
TABLE CLAMP
LEVER

Remove the table clamp lever from serrated shaft by releasing the set screw in hub, then reset in making the desired adjustment. (No. 11)

VERTICAL HEAD
CLAMP LEVER
ADJUSTMENT

Head clamp lever (No. 63) is adjustable by movement of double nut on outer end of clamping stud.

ARBOR SUPPORT
BUSHING
ADJUSTMENT

Horizontal machines - The greatest destroyer of rigidity and finish is a loose fit between the arbor support bushing and arbor bearing. The arbor supports (No. 35) are equipped with a circular notched nut for adjustment when necessary. To properly adjust the support bushing to the arbor bearing:

- 1) Mount arbor to machine spindle
- 2) Remove half the spacing collars and bearing on arbor
- 3) Place arbor support in position and clamp to overarms
- 4) Slip bearing on arbor and slide through bushing of support
- 5) Remove lock screw from groove at outer diameter of adjusting ring at front face of support
- 6) Tap adjusting ring to right until slight drag is felt when pushing bearing through arbor bushing
- 7) Place lock screw into groove of adjusting ring

DOUBLE OVERARMS

The overarms consist of two parallel round steel bars having a sliding fit in column bores and laced together at outer end by broad triangular arbor supports, insuring positive alignment of the arbor. The overarms are clamped in solid metal all the way around the bars and regardless of whether front or rear self-equalizing clamp block is tightened first, the alignment remains unchanged. The overarms are locked securely by means of two clamp nuts at top of column (No. 48). The pilot wheel can be withdrawn to move one overarm and engaged to move both arms at one time. (No. 3)

ARBOR SUPPORTS

When applying or removing arbor supports (No. 35) always extend one overarm a slight distance ahead of the other. This procedure provides the convenience of one single arm for handling supports with ease and speed. It is not necessary to remove the arbor support for cutter or arbor changes, merely extend one overarm several inches beyond the other to act as a swivel point, withdraw support to end of extended overarm and swing support upward to rest on inner arm.

NOTE: Before moving arms or applying arbor supports, be certain exposed surfaces of overarms are clean and covered with a film of oil.

The arbor supports (No. 35) have a lubricant reservoir provided with sight gauge for automatically oiling the arbor bearing and support bushing.

If the work to be milled permits only one arbor support and that support is a considerable distance from the column, additional rigidity can be had by mounting one arbor support upside down on the overarms at a central point between the column and the support in use. When more than one support is needed place them in position before clamping to overarms.

NOTE: Always tighten and loosen arbor nuts with arbor supports in place on arbor.

OVERARM BRACE

On heavy milling cuts it is good practice to apply the overarm brace (No. 41) to tie the knee and overarms together. Set up the job to be milled. Then move the overarms to the desired position being certain that the front face of each overarm is flush with the outer face of support. Apply overarm brace to knee, forming contact of inner face of brace with arbor support. Lock brace firmly to knee and bolt to arbor support. Be certain to eliminate all twists as brace must be parallel when bolted to prevent springing of arbor. Arm brace is adjustable along the knee top in reducing the distance from column to brace materially increases rigidity to the set up.

CUTTERS, ARBORS, COLLETS, ADAPTERS, etc.

All Milwaukee Milling Machines are equipped with standardized spindles, the taper being 3-1/2" per foot. For best results use our high grade line of standard arbors which are accurate and

properly heat-treated to meet the maximum requirements of milling. Kearney & Trecker Corporation manufactures arbors, collets, centering plugs, etc.;, as well as inserted blade face mill cutters, with high speed stellite and tipped tungsten carbide heavy duty blades, these cutters in sizes from three inches in diameter and up to 16" and can be applied to any make of machine in proportionate size, and manufactured to fit either the No. 40 or No. 50 standardized spindle end. We will gladly furnish our arbor and cutter literature upon request.

FOR BEST RESULTS

In attaching an arbor to a machine spindle, see that both the taper hole in the spindle and taper arbor shank are perfectly clean. Turn the spindle until the driving keys are in a horizontal position. The notches in the arbor flange will then catch on the driving keys to support the arbor until it can be caught by the draw-in rod. Due to the steep non-sticking angle of arbor tapers and to avoid the possibility of the arbor dropping or falling and marring the machine, the arbor should always be held by hand, until the threads of the draw-in rod have started in the arbor. When placing collars on arbors, be sure to clean the ends as dirt, grit or nicks will cause the arbor to spring. This same procedure should also be followed when applying cutters, collars and bearings to arbors. After cutters and collars have been properly placed, tighten the arbor nut by hand after which the arbor support should be put in place and secured. Then tighten the arbor nut with a wrench which can be done without danger of straining or springing the arbor.

When collets, plugs or face milling cutters are attached to the machine spindle, the same care should be taken to see that the taper hole and face of spindle as well as the shank of the collet, plug, arbor or cutter, is clean and free from burrs and nicks. Standard collets, plugs and arbors of any type are drawn into the taper hole of the spindle by the draw-in rod.

-- NOTE --

WHEN ORDERING OR INQUIRING ABOUT PARTS FOR THE MACHINE, BE SURE TO MENTION THE SERIAL NUMBER STAMPED ON BOTH SIDES OF THE COLUMN.

K E A R N E Y & T R E C K E R
Corporation

Milwaukee Wisconsin

MODEL H

WORMWHEEL TYPE SPIRAL UNIVERSAL DIVIDING HEAD 40 to 1 Ratio

K E A R N E Y & T R E C K E R
Corporation

UNIFORM ACCURACY UNDER ALL LOADS

The Model H Wormwheel Dividing Head, like the Hypoid Type Dividing Head, is a practical, rugged instrument developed for use in the toolroom, inspection department, laboratory, and its ruggedness will permit continuous heavy duty performance on production requirements. The Model H Head is modern, not salvaged from older designs, and it is capable of the superior performance and accuracy built into every Model H Milwaukee Milling Machine.

THE MEANING OF OIL FILM FLOAT

In every plain bearing dividing head spindle, there must be an oil film or the spindle could not be revolved. Even though the oil film is thin, it is one of the greatest destroyers of dividing accuracy. Without any load, the plain bearing spindle will show an "apparent accuracy" that measures up to general requirements. Place that same bearing spindle under the load of average cutting pressures, and the oil film is squeezed to one side with the result that "performance accuracy" (that is, accuracy of the work produced) does not measure up to the "apparent accuracy" of the plain bearing head when idle.

OIL FILM FLOAT HAS BEEN OVERCOME

Realizing the inaccuracy caused by oil film float, this practical dividing head was developed in which THERE IS NO OIL FILM ON THE SPINDLE TO FLOAT. Instead of ordinary plain bearings, the rugged spindle is mounted on oversize and matched precision anti-friction bearings, that are pre-loaded at the factory to several hundred pounds pressure. This pre-loading provides a metal to metal bearing contact with no oil film and consequently no oil film to float. For the first time "performance accuracy" equals no load "apparent accuracy".

A PRACTICAL SPINDLE MOUNTING

It is practical to have anti-friction bearings on dividing head spindles, as it is to provide anti-friction bearings to spindles of modern milling machines.

ADJUSTMENT

Dividing head pre-loaded anti-friction bearings are properly assembled when built and require no further adjustment at any time during the life of the attachment.

STANDARDIZED
SPINDLE END

The hardened and ground head spindle has a No. 40 standardized taper, non-sticking 3-1/2" per foot. All arbors, having the No. 40 taper shank are interchangeable between the head and machine spindles with identical tapers. An expanding key in the spindle end provides a metal to metal positive drive to the work driver, center, chuck, etc. The hole through head spindle is one inch in diameter.

DIVIDING
HEAD CHUCK

The Universal three jaw 6" diameter chuck centers over the outer diameter of head spindle, three bolt holes through chuck body permit locking chuck securely to face of dividing head spindle. The dividing head spindle nose is provided with a positive lock which prevents chuck slippage on indexing and spiral milling.

STANDARD
INDEX
PLATES

Three standard index plates are furnished as standard equipment. The plate holes are precision diamond bores, and self-cleaning as the holes are bored clear through, which also permits a full center bearing on crank locating pin. Divisions obtainable by simple indexing include all numbers in sequence from 2 to 100, except 51, 53, 57, 59, 61, 63, 67, 69, 71, 73, 77, 79, 81, 83, 87, 89, 91, 93, 96, 97 and 99. Many additional numbers are possible with the three standard index plates, to a range up to 520 Divisions as outlined in instruction book furnished with attachment.

HIGH NUMBER
INDEX PLATES

Four additional index plates can be supplied which permit PLAIN INDEXING on the combined seven plates, of all numbers from 2 to 100 and to include all even numbers up to 200 and all numbers divisible by five up to 520 divisions, except 125, 175, 225, 250, 275, 325, 350, 375, 425, 450, 475, 500 and 515.

Simple or plain indexing reduces the possibility of error and eliminates the former method of old style differential indexing.

LARGE WORMWHEEL
AND NEW TWO-PIECE
WORM INCREASES
ACCURACY

The Model H Dividing Head spindle has a 3-1/2" overall diameter, and is driven by a 4-5/8" diameter wormwheel which revolves on two preloaded super precision bearings 4-7/8" and 3-1/8" diameter respectively. The generous size of the worm wheel provides ample reserve strength for all spindle loads, and meshes with a patented two piece worm hardened and ground, of 1-5/16" diameter which eliminates the old fashioned customary cam or eccentrics for taking up wear between the worm and wheel. Adjustment for wear is accomplished by merely bringing the two sections of worm closer together without disturbing their fixed axis of rotation. In this manner the accuracy of the worm and wormwheel is never destroyed. The tooth contact relation remains unchanged and actually improves with service.

TWO PIECE WORM ADJUSTMENT

The worm adjustment is made by releasing the slotted screw at top end of upper cover which permits turning the adjusting nut. Revolve the nut, to the right by means of holes provided, in outer diameter, until the lash between the worm and worm wheel is eliminated.

LUBRICATION

Add a few drops of oil daily through screw cap oilers at top and side of head. When shipped from the factory the dividing head mechanism is protected with anti-rust lubricating oil (Stanorust No. 0 as made by the Standard Oil Company) to a level permitting the worm wheel to dip into this oil reservoir as it revolves. When necessary add the specified grade of oil through the larger screwed cap opening on worm wheel housing. This reservoir oil level can be checked by the slotted plug in the small cover located to the left inner side of index plate. Although anti-rust oil is recommended and is far more satisfactory for long life, a good grade machine oil, Viscosity 300 to 325 Saybolt at 100°, can be used if desired.

NOTE: To prevent damage of driving and indexing mechanism be certain screw cap oilers are properly secured at all times.

OIL SEALS

The head is protected with seals to prevent oil leakage regardless of whether the spindle is set to any degree from the horizontal to the vertical position.

POSITIVE CLAMPING

Large diameter self-equalizing clamps that grip all the way around are used to clamp the spindle, the spindle block and index plates. This circular clamp feature, permits equal pressure which prevents springing and distortion. The spindle is clamped with the square head set screw (No. 52).

NOTE: When indexing the spindle, clamp and index plate and free the spindle clamp (No. 52). When applying power to rotate head, release both the index plate and spindle clamps.

CUTTING LEADS BELOW 8" USING LOW LEAD ATTACHMENT

For all leads below 8" lock the table feed lever (No. 29) in neutral, using the knurled screw provided in the lever for locking purposes. Table feed direction lever (No. 27) replaces feed lever (No. 29) for all leads below 8"; lever (No. 27) is directional and moved to the left for left hand feeds and to the right for right hand feeds. Plunger lever (No. 26) is also directional and operates the lead reverse clutch for changing the hand of the spiral. Lever (No. 27) operates in conjunction with plunger lever (No. 26) and when lever (No. 27) is shifted to the left, lever (No. 26) should also be moved to the left. When lever (No. 27) is moved to the right, lever (No. 26) should also be moved to the right. Place the index plunger pin in any hole in the outside row. Loosen knurled lock ring nut (No. 22) that clamps the index plate. Loosen the square head set screw (No. 52) that clamps the spindle. Place hand crank on square end inside the lead box and check the set up by hand before applying power with movement of lever (No. 27) on all leads under 8".

For tripping table movements automatically on low leads up to 8", attach feed trip rod (No. 28) to front of table and connect rod to slot at shaft end of table direction lever (No. 27) set adjustable trip blocks along rod to any desired position for contacting locked directional table feed lever (No. 29). In this way tripping of table is accomplished on low leads to desired limit movements on spiral work mounted between centers.

NOTE: When it is desired to rotate the dividing head or rotary table by power feed or rapid traverse (using Low Lead Attachment) and not transmit any movement to the milling machine table (for cutting outer diameter to circles or "Dwells" on cams, etc.) Lock table feed lever (No. 29) in neutral, disconnect worm or worm wheel from table screw in low lead box, and engage levers (Nos. 26 and 27).

CUTTING LEADS ABOVE
8" USING LOW LEAD
ATTACHMENT

For all leads above 8", the drive is taken direct from the table screw and the auxiliary drive shaft is entirely disconnected. Table direction lever (No. 27) on low lead box is locked in neutral using the knurled screw in this lever provided for that purpose. All feeds and power are now applied through table feed lever (No. 29) for cutting leads above 8".

CONVENTIONAL LEAD
ATTACHMENT

This attachment is equipped with change gears for cutting leads by power from 2-1/2" to 149". The auxiliary drive shaft is omitted and power is taken directly from the table screw. Before applying power, check all set ups by hand, using the hand crank (No. 12) on the left end of table screw.

POWER RAPID
TRAVERSE TO
HEAD

When the machine is set up on power lead drives power rapid traverse is available in returning the head to the starting position after a lead has been milled, without disturbing the set up.

1) On machines equipped with the LOW LEAD ATTACHMENT the power rapid traverse can be applied on all leads - when the lead is set up as outlined in the lead book furnished.

2) On machines furnished with the standard CONVENTIONAL LEAD ATTACHMENT power rapid traverse can only be used on leads from 10.000" and up, as outlined in lead book furnished with this equipment.

NOTE: Engage the power rapid traverse lever (No. 54) GENTLY when driving through a lead attachment, to avoid damage should a desired lead be set up in error. Test all lead set ups by hand movement before applying power.

LEAD BOOKS

The lead books furnished with Universal machines outline the application of either the conventional or Low Lead attachments corresponding with the unit supplied with the machine. All standard leads are specified including the change gear set up in obtaining any given lead.

LOW LEAD ATTACHMENT - With the use of this attachment 42.362 leads are possible within the range as listed in the lead book furnished. Any desired lead set up not listed in the standard lead book can be furnished in a few minutes time by exchange of telegrams with the home office at Milwaukee.

Master Lead books incorporating all 42.362 leads can be purchased at slight extra cost.

CONVENTIONAL LEAD ATTACHMENT - With the use of this standard attachment 1.334 leads are possible with the fourteen change gears furnished. Every lead set up is outlined in the lead book supplied with this equipment.

Both lead books outline all individual divisions of indexing, with the use of either the standard or high number plates. Each possible division is itemized in selecting the proper plate and hole circle with the turns of crank and holes necessary in obtaining a desired division to head spindle.

- 1) Adjustable starting lever with built-in push button control.
- 2) Machine model and serial number, used in seeking information or parts.
- 3) Pilot wheel for sliding one or both overarms in and out.
- 4) Sight guage tells instantly whether gears and bearings are getting oil.
- 5) Speed range lever (High-Low).
- 6) Speed change lever (R. P. M.).
- 7) Speed change selective lever.
- 8) Built-in mechanical spindle reverse; does not reverse feeds.
- 9) Column reservoir oil level guage.
- 10) Permanent table limit stops.
- 11) Adjustable table clamp lever, (for boring operations).
- 12) Table crank, disengages when hand pressure is released.
- 13) Cap opening for saddle lubrication. Fill daily.
- 14) Cross-mounted motor; easy to get at.
- 15) Saddle clamp lever.
- 16) Breather plate to prevent condensation in the knee.
- 17) Adjustable knee clamp lever.
- 18) Knee combination oil level and flow guage.
- 19) Feed change lever.
- 20) Coolant screen covers.
- 21) Adjustable double joint coolant nozzles.
- 22) Knurled nut locking ring for index plate.
- 23) Adjustable graduated dial--in minutes--one complete revolution 90° at head spindle.
- 24) Adjustable splined drive shaft connecting drive unit to head.
- 25) Low Lead Box (not standard equipment)--40,362 leads from .022" to 2918".
- 26) Lead Reverse clutch reverses hand of spiral.
- 27) Table direction lever for leads below 8".
- 28) Feed trip rod for leads below 8".
- 29) Directional table feed lever for leads over 8".
- 30) Directional cross feed lever.
- 31) Cross handwheel.
- 32) Vertical hand crank.
- 33) Directional vertical feed lever.

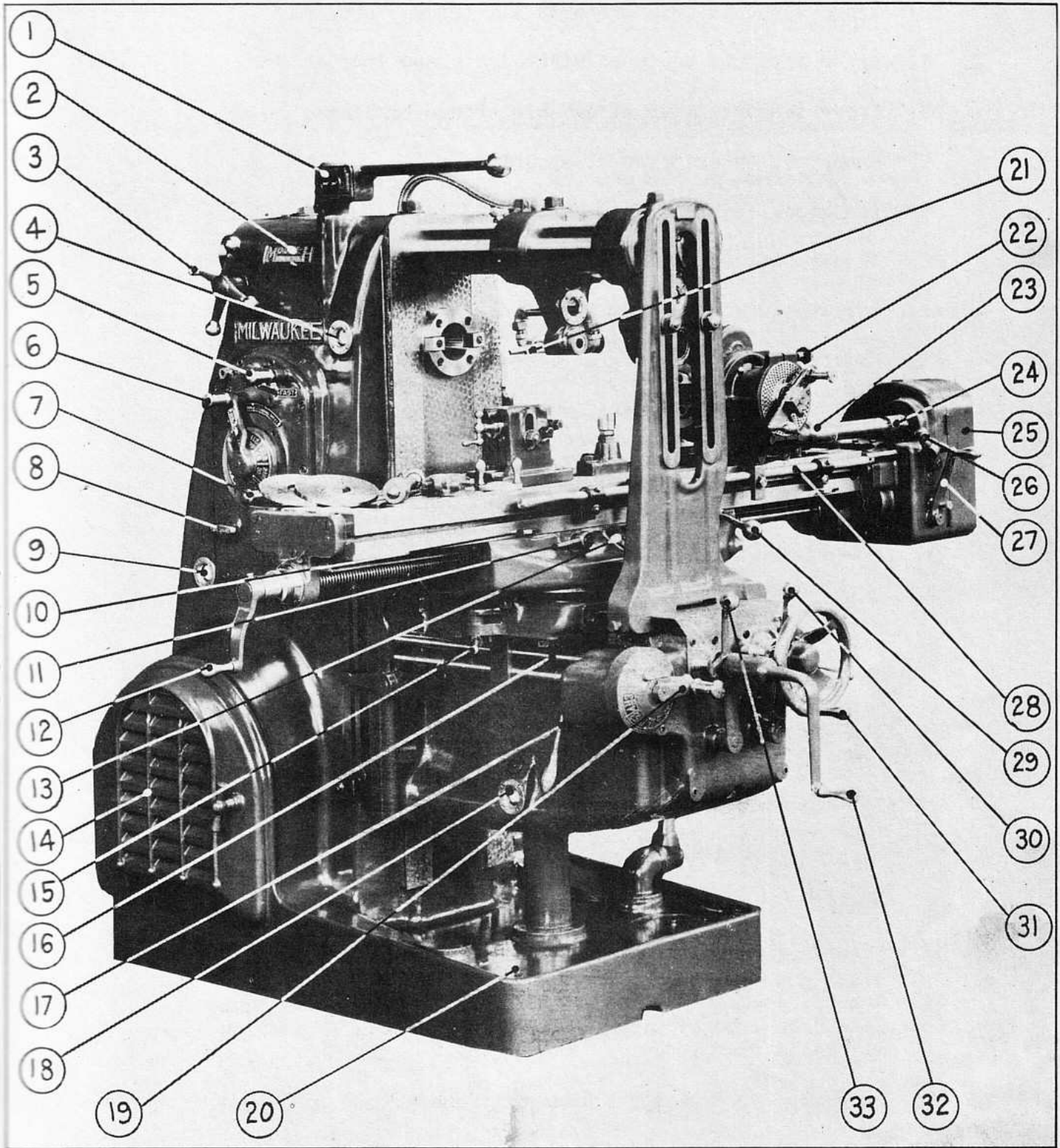

- 34) Non-distorting arbor support clamps.
- 35) Arbor supports grip overarms all the way around.
- 36) Arbor supports equipped with sight feed lubricators.
- 37) Arbor supports with adjustable bronze bushings.
- 38) B support outer brace clamp bolts.
- 39) Tailstock center clamp bolt.
- 40) Adjustable center rest.
- 41) Adjustable arm brace - close coupled setups.
- 42) Knurled screw for locking table feed lever in neutral.
- 43) Head crank, index plate and sector fingers.
- 44) Adjustable table trip dogs.
- 45) Power rapid traverse lever.
- 46) Cover plate for rapid traverse clutch adjustment.
- 47) Telescopic coolant return tube.
- 48) Equalized clamps firmly grip both overarms without springing column.
- 49) Adjustable coolant pipe clamp ring - mount on either overarm.
- 50) Adjustable coolant valves - double joint outlets.
- 51) Air breather plate - to prevent condensation in column.
- 52) Dividing head spindle clamp screw.
- 53) Drive clutch adjustment lock pin.
- 54) Covered lead gear unit (Conventional) - range of leads 2-1/2" to 149" by power. Rapid traverse can be used on all leads over 10".
- 55) Pipe cap for draining column oil reservoir.
- 56) Pulley door, covers drive sheaves and belts.
- 57) Coolant pump drive clutch - snaps on.
- 58) Coolant pump.
- 59) Knee reservoir drain plug.

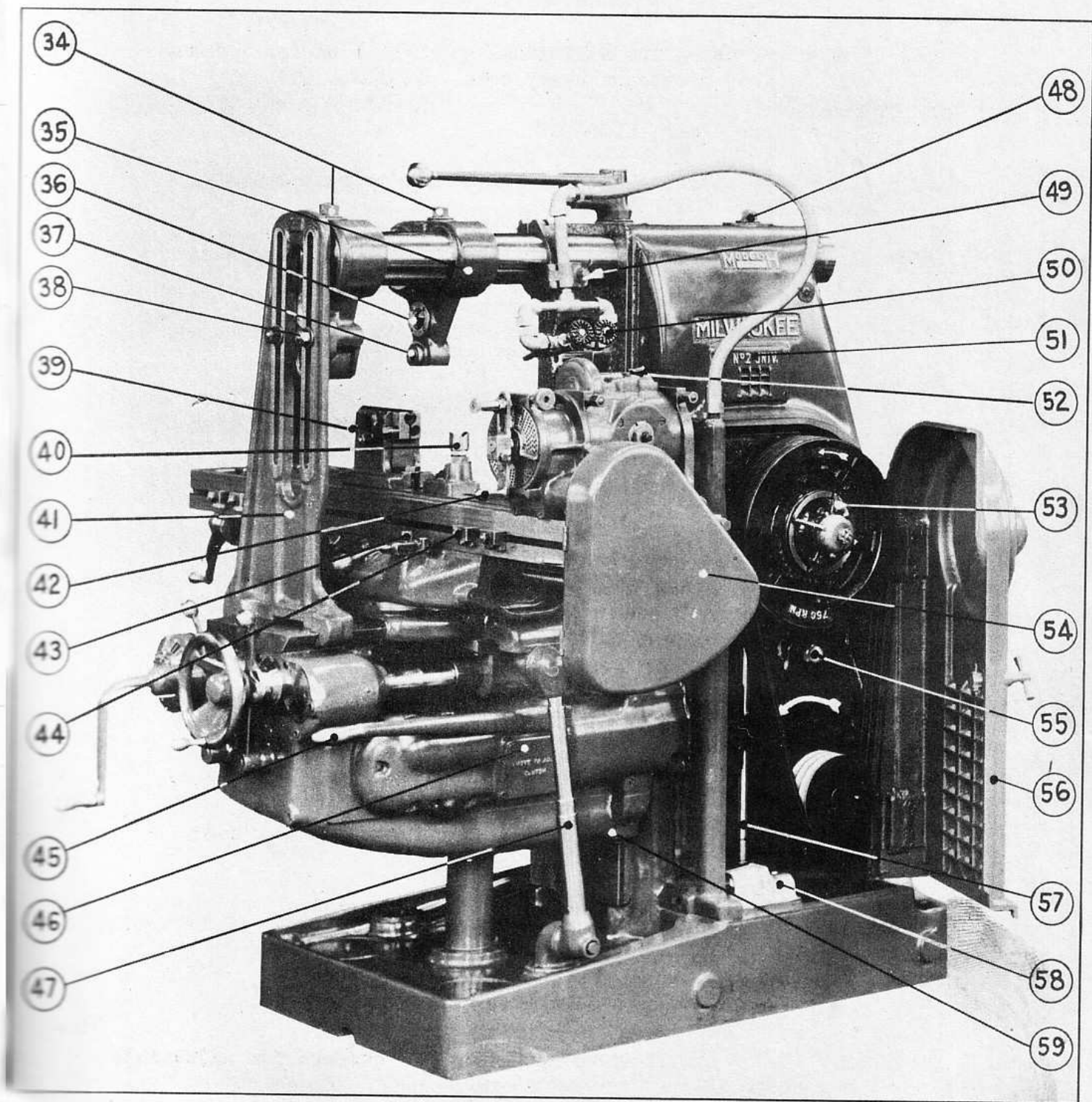

- 60) Head clamp nut - two additional at right side for locking head at four points on heavy cuts. (See No. 63)
- 61) Speed range lever (HIGH-LOW).
- 62) Adjustable starting lever - can be set to suit operator's convenience.
- 63) Adjustable clamp lever for locking head, used when step milling.
- 64) Adjusting nut for spindle, exposed by removing cover.
- 65) Built-in push button control.
- 66) Column oil sight gauge.
- 67) Draw-in bolt.
- 68) 4-position adjustable stop rods.
- 69) Micrometer stop rod indexing lever.
- 70) Micrometer stop rod adjusting nuts.
- 71) Feed trip arm, also operates indicator.
- 72) Adjustable micrometer dial.
- 73) Sliding head handwheel - automatic disengagement.
- 74) Combination sight and drip gauge - filler cap and drain plug.
- 75) Adjustable trip dogs (Never remove from head).
- 76) Head clamp nuts. (Two right side).
- 77) Directional control lever for power head movements.
- 78) Stop pins - for limit of head travel - bumpers for adjustable trip dogs.
- 79) Universal adjustable coolant pipe clamp.
- 80) Adjustable coolant flow valve.

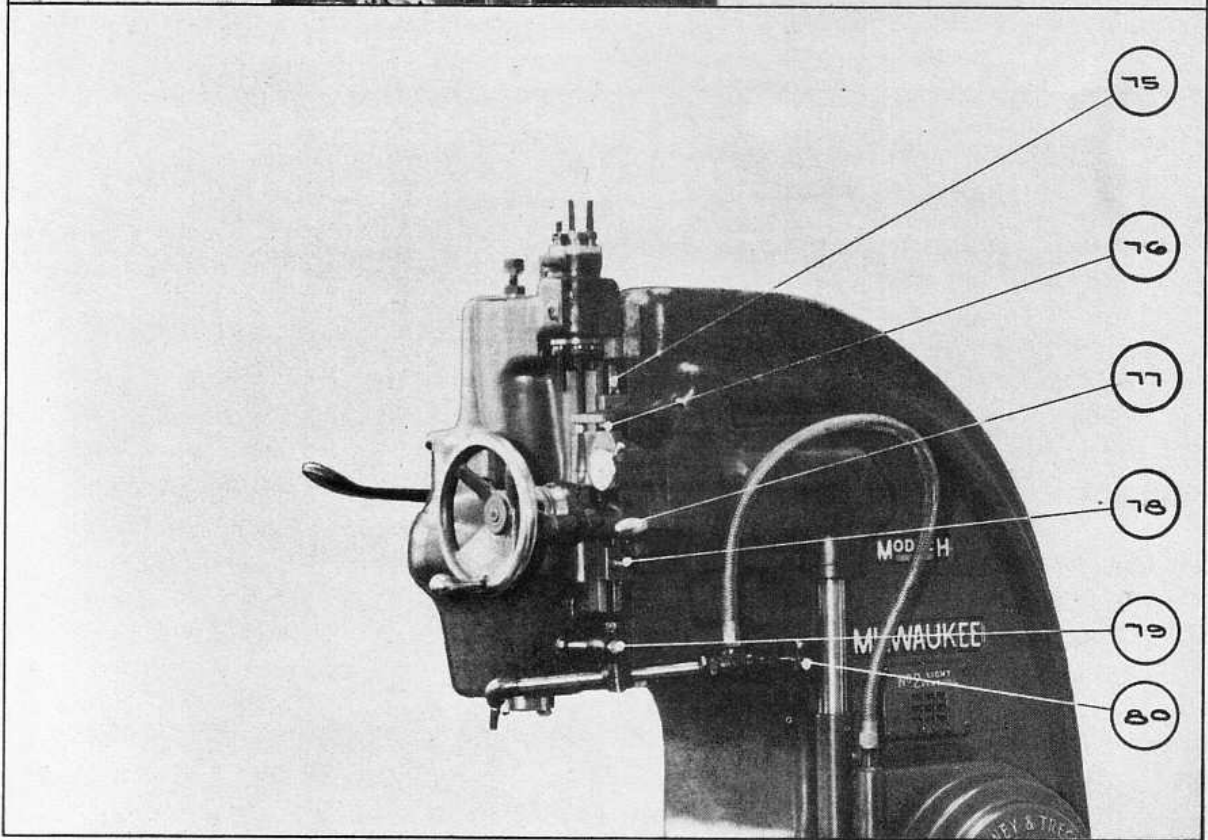
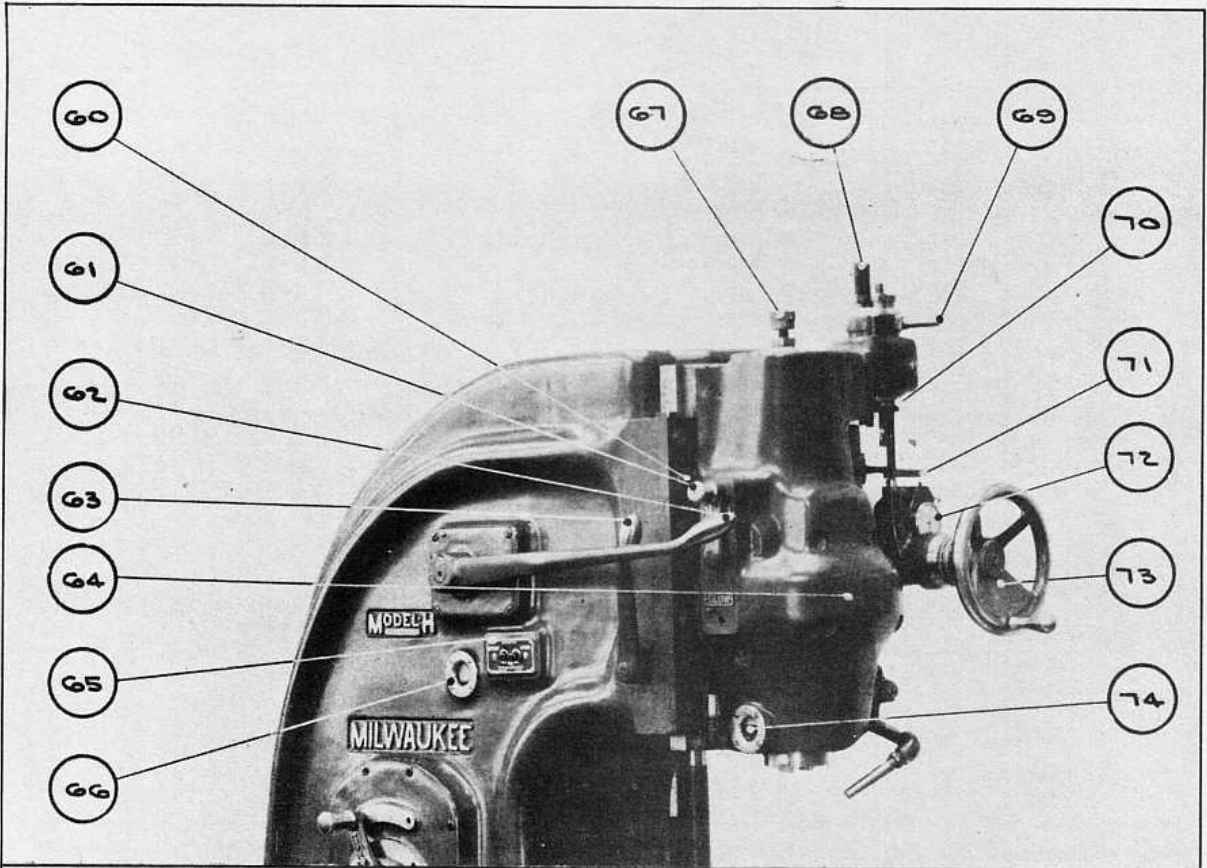

(1) Rules For Determining Speeds And Feeds

SAMPLE SPEED AND FEED CALCULATION.

PROBLEM: Determine proper SPEED and FEED of a 5" diameter face mill with 10 High Speed Steel blades, milling cast iron.

A) TO DETERMINE SPEED DIAL SETTING (Cutter R.P.M.):

RULE: Divide the feet per minute (F.P.M.) by the circumference of the cutter, expressed in feet.

$$\text{FORMULA: } \text{F.P.M.} \div \frac{\text{Dia. of cutter} \times \pi}{12} = \text{R.P.M.}$$

From Chart 2 under H.S. in Cast Iron, 80 F.P.M. (range 50-80) is selected.

$$\text{Therefore: } 80 \div \frac{5 \times 3.1416}{12} = \text{R.P.M.}$$

$$\begin{array}{r} 3.1416 \\ 5 \text{ in. dia.} \\ \hline 15.7080 \end{array} \quad \begin{array}{r} 1.31 \\ 12) 15.71 \\ \hline 1.31 \end{array} \quad \begin{array}{r} 61.1 = \text{R.P.M.} \\ 61.1 \text{ R.P.M.} \\ 1.31) 80.00 \end{array}$$

SHORT FORMULA FOR SPEED:

$$\frac{4 \times \text{F.P.M.}}{\text{Diam. of Cutter}} = \text{R.P.M. or } \frac{4 \times 80}{5} = 64 \text{ R.P.M.}$$

B) TO DETERMINE FEED DIAL SETTING (Feed in inches per minute = F):

RULE: Multiply feed per tooth per revolution by number of teeth in cutter and by the speed (number of revolutions per minute.)

FORMULA: F.T.R. x T. x R.P.M. = F (Feed)

From Chart 3 under Face Mill H.S. in Cast Iron a F.T.R. (chip load) of .012 is selected (range .010-.025). R.P.M. is 61 from speed calculation.

$$\text{Therefore: } .012 \times 10 \times 61 = \text{Feed.} \\ 7.32 = \text{Feed.}$$

RESULT: For the 5" diameter face mill cutter with 10 High Speed blades, milling cast iron—

The SPEED dial setting is 61 R.P.M.
The FEED dial setting is 7.32 I.P.M.

NOTE: The speeds and feeds determined by mathematical computation are approximate and dial settings closest to these results (either higher or lower) are normally satisfactory as a starting point.

TO FIND	HAVING	RULE	FORMULA
Speed of Cutter in Feet per Minute (F.P.M.)	Diameter of Cutter and Revolutions per Minute	Diameter of Cutter (In.) Multiplied by 3.1416, Multiplied by Revolutions per Minute, Divided by 12	$\frac{D \times \pi \times \text{R.P.M.}}{12} = \text{F.P.M.}$
Revolutions per Minute (R.P.M.)	Feet per Minute and Diameter of Cutter	Feet per Minute, Divided by Circumference of Cutter in Feet (Diameter x 3.1416 ÷ 12)	$\frac{\text{F.P.M.} \div D \times \pi}{12} = \text{R.P.M.}$
Feed per Revolution (F.R.)	Feed per Minute and Revolutions per Minute	Feed per Minute, Divided by Revolutions per Minute	$\text{F.} \div \text{R.P.M.} = \text{F.R.}$
Feed per Tooth per Revolution (F.T.R.)	Feed per Minute and Number of Teeth in Cutter	Feed per Minute (In.), Divided by Number of Teeth per Minute (Number of Teeth in Cutter x Revolutions per Minute)	$\text{F.} \div (\text{T.} \times \text{R.P.M.}) = \text{F.T.R.}$
Feed per Minute (F.)	Feed per Tooth per Revolution, Number of Teeth in Cutter, and Revolutions per Minute	Feed per Tooth per Revolutions Multiplied by Number of Teeth in Cutter, Multiplied by Revolutions per Minute	$\text{F.T.R.} \times \text{T.} \times \text{R.P.M.} = \text{F.}$
Feed per Minute (F.)	Feed per Revolutions and Revolutions per Minute	Feed per Revolution Multiplied by Revolutions per Minute	$\text{F.R.} \times \text{R.P.M.} = \text{F.}$
Number of Teeth per Minute (T.M.)	Number of Teeth in Cutter and Revolutions per Minute	Number of Teeth in Cutter Multiplied by Revolutions per Minute	$\text{T.} \times \text{R.P.M.} = \text{T.M.}$

R.P.M. = Revolutions per Minute

T.M. = Teeth per Minute

T. = Teeth in Cutter

F. = Feed per Minute

D. = Diameter of Cutter

F.R. = Feed per Revolution

$\pi = 3.1416 (\text{Pi})$

F.T.R. = Feed per Tooth per Revolution

F.P.M. = Speed of Cutter in Feet per Minute

(2) Guide To Correct Speed Selection

FOLLOW LINES TO CUTTER & R. P. M. AS SHOWN BY ARROWS

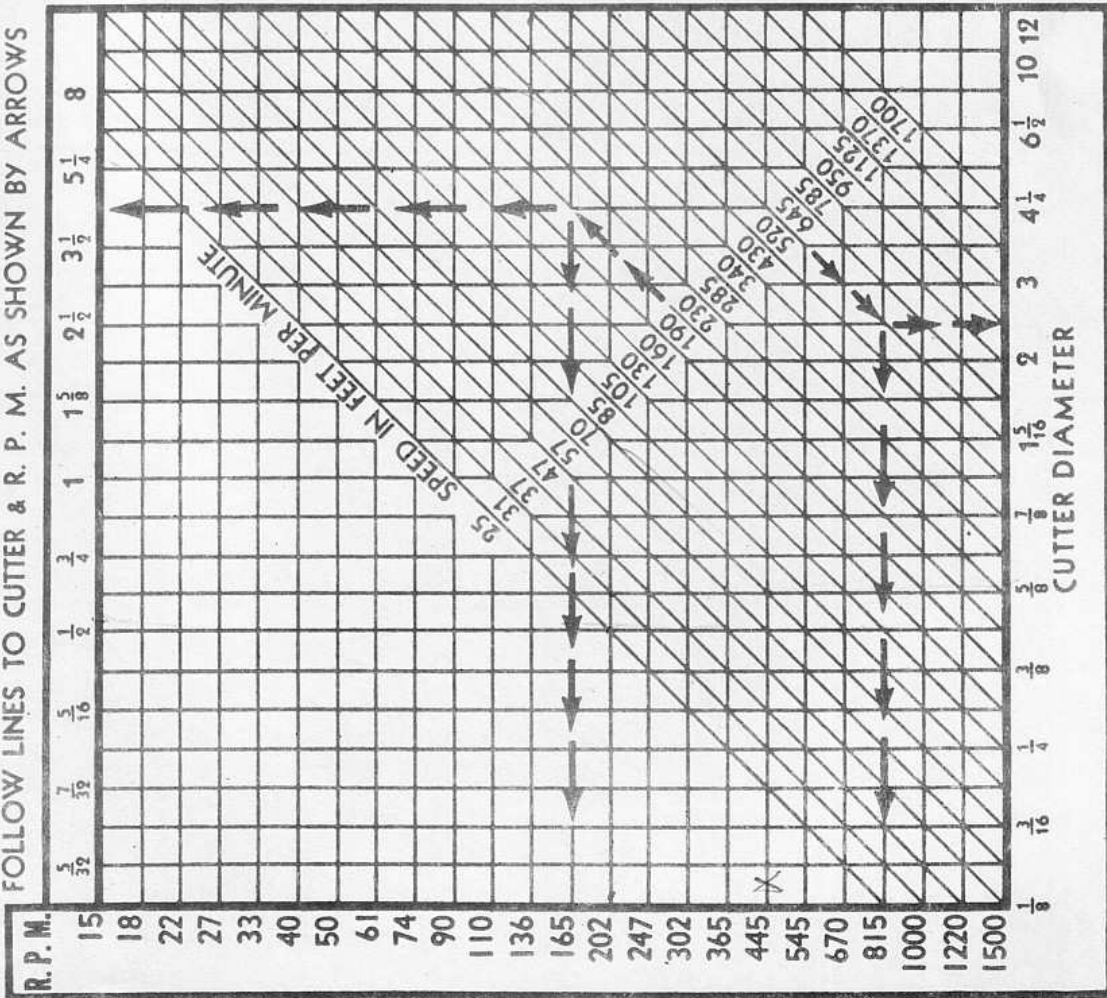

Learn what cutters will stand. Start with slow speeds and feeds and step up.

Material To Be Milled	MATERIAL IN CUTTER					
	Carbon Tool Steel	High Speed Steel	Super Hi-Speed Steel	Stellite	Tantalum Carbide	Tungsten Carbide
	CUTTER SPEED IN FEET PER MINUTE					
Aluminum	250-500	500-1000		800-1500		1000-2000
Brass Soft	40-80	70-175		150-250		350-600
Bronze Hard	30-60	65-130		100-160		200-425
Bronze Very Hard		30-50	50-70			125-200
Cast Iron Soft	30-40	50-80	60-115	90-130		250-325
Cast Iron Hard		30-50	40-70	60-90		150-200
Cast Iron Chilled			30-50	40-60		100-200
Malleable Iron	35-50	70-100	80-125	115-150		250-370
Steel Soft	30-45	60-90	70-100		150-250	
Steel Medium	30-40	50-80	60-90		125-200	
Steel Hard		30-50	40-70		100-150	

(3) Guide To Correct Feed Selection

Feed per Tooth per Revolution = Chip Load

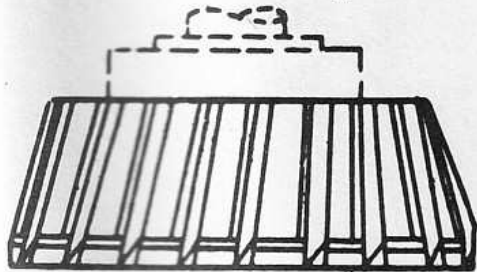

Face Mill

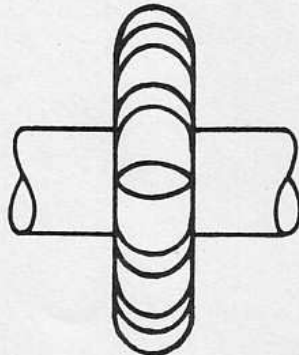

Form

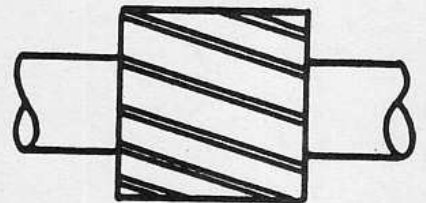

Plain Slab

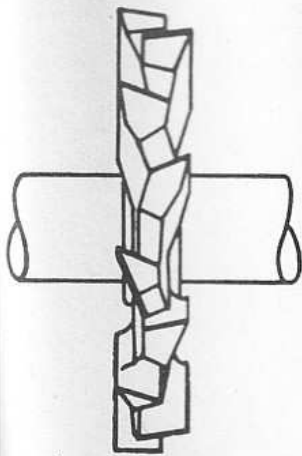

Staggered Tooth



Spiral
End Mill



Two-Lipped
End Mill

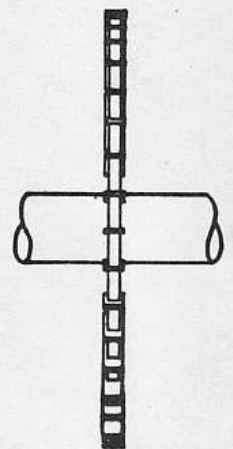

Saw

Recommended Chip Load Tables

Type of Cutter	In Cast Iron	In Steel	In Brass Bronze Aluminum
Face Mill, H. S.	.010 to .025	Less 40%	Plus 50%
Slab Mill, H. S.	.010 to .015	Less 40%	Plus 50%
Slotting Cutter, H. S.	.006 to .012	Less 40%	Plus 50%
Form Mill, H. S.	.004 to .006	Less 40%	Plus 50%
End Mill, H. S.	.002 to .010	Less 40%	Plus 50%
Saw, H. S.	.001 to .003	Less 40%	Plus 50%
Cemented Carbide Face Mill	.008 to .012	.004 to .008	.010 to .016

In general, select the proper SPEED for work material and cutter; and then determine the feed, within the above limits, according to the cut and the power available or the finish required.

PRINTED IN THE UNITED STATES OF AMERICA

