

**SERVICE MANUAL**  
*and*  
**REPAIR PARTS**  
**Catalog**

*Cincinnati*  
**Nos. 1-2-3-4**  
**DIAL TYPE**  
**MILLING**  
**MACHINES**



(Use This Catalog Only for Machines in which The Third  
Numeral and Letter of The Serial Number are 2H or Lower)

THE **ROBERT R. STEPHENS MACHINERY CO.** CO.

8145 OLIVE BLVD. • WYDOWN 1-0502 • ST. LOUIS 30, MISSOURI

*Branch Offices:*

Suite 5, Barclay Bldg.  
Kansas City 11, Missouri  
LOgan 1-2123, 1-4925

9830 Par Lane  
Wichita 12, Kansas  
PARkview 2-1591

Room 220, Utica Bldg.  
Tulsa 4, Oklahoma  
RIVERSide 7-4609

579

# SERVICE MANUAL AND REPAIR PARTS CATALOG



## Nos. 1-2-3-4 DIAL TYPE MILLING MACHINES

(MEDIUM SPEED AND HIGH SPEED)

• • •

● This service manual and repair parts catalog was made for the purpose of helping the maintenance foreman, millwright and the operator to know the correct method of installing and caring for the machine and to facilitate the ordering of repair parts. » »

● CINCINNATI milling machines are built to a high degree of precision and accuracy. When properly installed and with ordinary care they will give many years of good service. » »

• • •

**THE CINCINNATI MILLING MACHINE COMPANY**  
**CINCINNATI, OHIO, U. S. A.**



---

---

## CONTENTS

	PAGE
Lubrication Chart for All Machines.....	4
Lubrication Instructions and Specifications.....	5
Nomenclature Chart.....	6
Installation Instructions.....	7-8
Adjusting the Gibs and Main Driving Clutch.....	8
Adjusting the Rapid Traverse Clutch.....	9
Removing Leadscrew.....	10
Removing Table.....	11
Removing Universal Housing.....	11
Removing Cross Screw.....	11
Removing Cross Screw Nut Bracket.....	12
Removing Saddle.....	12
Removing Spline Shaft Bracket.....	13
Removing Vertical Screw.....	13
Removing Change Gear Bracket.....	14
Removing Lubricant Pump in Knee.....	14
Removing the Knee.....	15-16
Removing Coolant Pump.....	16
Removing Pulley Bracket.....	17
Removing Feed Box.....	17-18
Removing Gear Shifter Bracket.....	18
Removing Hand Feed Worm Box.....	19
Removing Power Feed Worm Box.....	19
Removing Vertical Spindle.....	19-20
Removing Vertical Head.....	20-21
Removing Horizontal Spindle.....	21
Adjustment of Spindle Bearings.....	22
Illustration of Front of Column.....	23
Removing the Back Gear Shaft.....	24
Removing Other Drive Shafts.....	25
Removing More Than One Unit.....	25
Removing the Overarm.....	25
Removing Rear Control Bracket.....	26
Setting the Oil Pressure of Pump in Column.....	26
Removing the Pressure Pump in Column.....	27
Lubrication of Column.....	27

---

---

## CONTENTS—Continued

	PAGE
How to Order Repair Parts.....	29
Pulley Bracket Unit Parts List.....	31
Coolant Pump and Piping Parts List.....	33
Gear Shifter Bracket Parts List.....	35
Feed Box Parts List.....	39
Column Parts List.....	43
Knee Unit Parts List.....	55
Saddle, Table, Housing Unit Parts List.....	63
Table Hand Feed Attachment Parts List.....	69
Hand Feed Worm Box Parts List.....	71
Power Feed Worm Box Parts List.....	73
Belt Drive and Motor Drive Parts List.....	75
Plain and Swivel Vise Parts List.....	77
Dividing Head Parts List.....	79
Tailstock Parts List.....	81
Wide Range Divider Parts List.....	81
Driving Mechanism Parts List.....	83
Open Type Driving Mechanism Parts List.....	85

### PATENT NOTICE

These machines and attachments are manufactured under and protected by issued and pending United States and Foreign Patents.

Copyright 1938  
The Cincinnati Milling Machine Co.  
Cincinnati, Ohio, U. S. A.

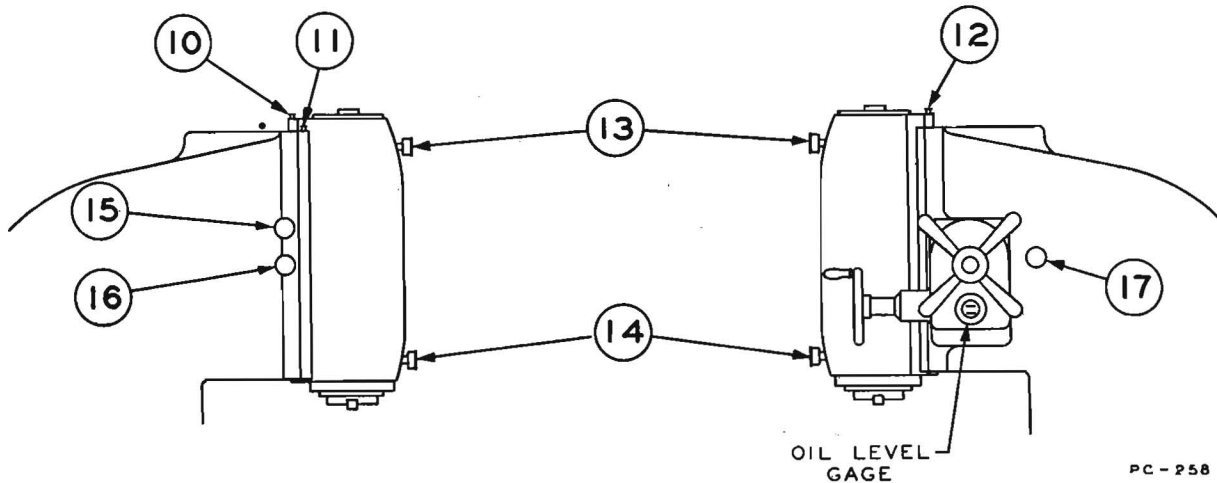

FIGURE 1

Lubrication Chart for Vertical Head of Medium Speed Machines

FIGURE 2

Lubrication Chart for Vertical Head of High Speed Machines

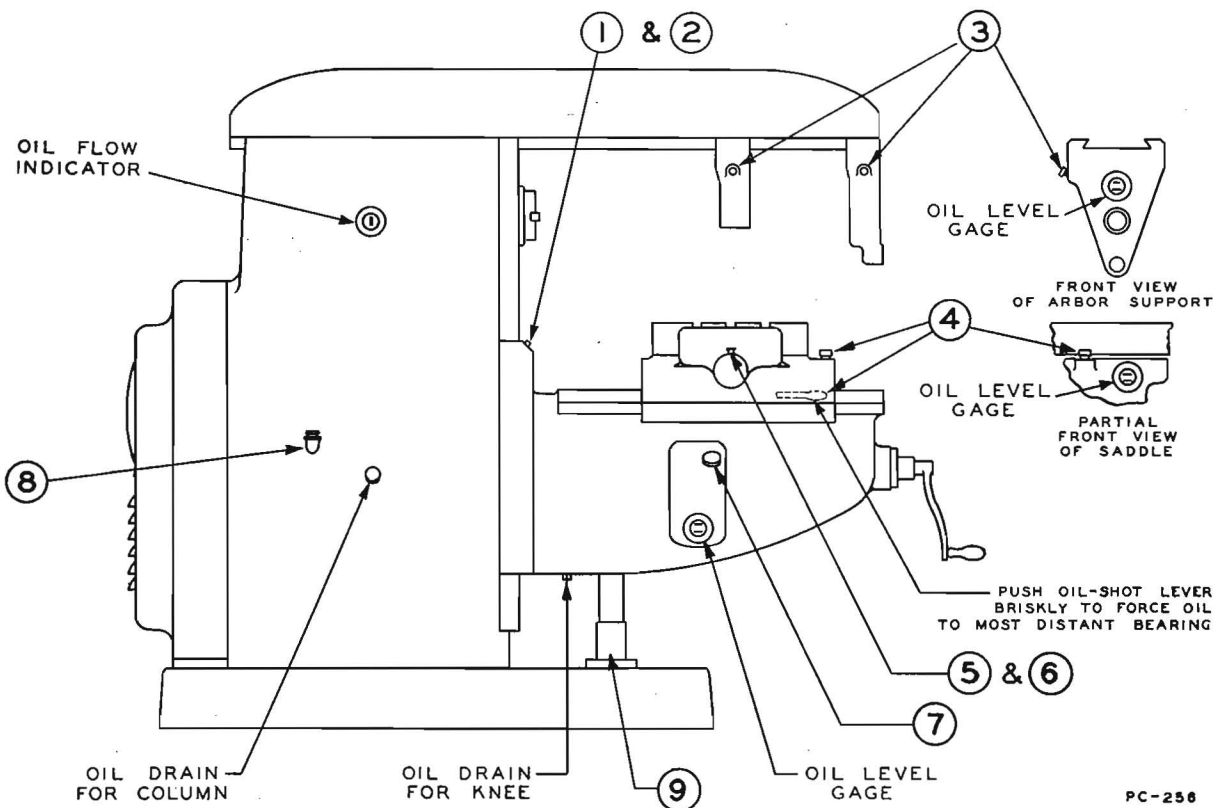

FIGURE 3

Lubrication Chart for Horizontal Machines, Medium Speed and High Speed



## LUBRICATING INSTRUCTIONS AND SPECIFICATIONS

ALL STYLES Nos. 1, 2, 3, AND 4 DIAL TYPE MILLERS

When to Oil	Station Number	Parts Lubricated	Lubricating Instructions	Specifications of Lubricant
Once a Day	1 and 2	Knee bearing surface on column	Oil from squirt can	Medium machine mineral oil. Viscosity 190 to 210 seconds Saybolt at 100° F.
	10 11 12	Head bearing surfaces on column (Verticals only)		
	5 and 6	Lead Screw Bearings		
Once a week	13 14 15 16 (Med. Speed only) 17 (High Speed only)	Spindle and bevel gear bearings (Verticals only)	Oil from squirt can.	Medium sponge, short fibre grease. Sodium soap base. (Superla 2X grease made by Standard Oil Co. of Indiana, or medium sponge grease made by Vacuum Oil Co.
	9	Vertical Screw	One full turn of grease cups once a week; <b>NO MORE</b>	
	3	Arbor bearing collar	Replace pipe plug in vertical screw base nut with grease fitting. Fill oil well with grease gun.	
Twice a Year	4	Saddle parts and knee bearings of the saddle.	Keep reservoir filled to line on gage. <i>Automatic Lubrication.</i>	Extreme pressure oil. Special heavy S.A.E. EP-250 grade or its equivalent.
	7	Knee parts	Keep reservoir filled to line on gage. Push lever of oil shot pump sharply six times twice daily.	
	8	All parts in column (except motor), including gear shifter bracket and feed box	Keep knee reservoir filled to line on gage. Keep column filled to threads of filler elbow. Drain and re-fill with clean oil after first month of operation. Thereafter drain and re-fill, while machine is idle, about twice a year, depending on operating conditions. <i>Automatic Lubrication.</i>	
	When oil reaches low limit on gage		Keep reservoir filled to line on gage. Keep column filled to threads of filler elbow. Drain and re-fill with clean oil after first month of operation. Thereafter drain and re-fill, while machine is idle, about twice a year, depending on operating conditions. <i>Automatic Lubrication.</i>	
Depends on make of motor and type of bearing construction		Motor Bearings	Front motor is accessible when door on rear of column is opened. Rear bearing is accessible when louvre on right hand side of column is removed.	Medium machine mineral oil. Viscosity 190 to 210 seconds Saybolt at 100° F.
			Depends on make of motor. Cup grease for anti-friction bearings, and oil for sleeve bearings.	

# NOMENCLATURE CHART

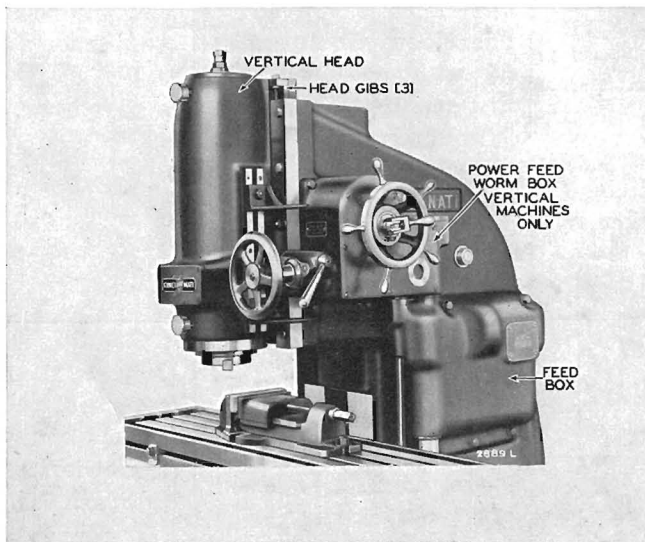
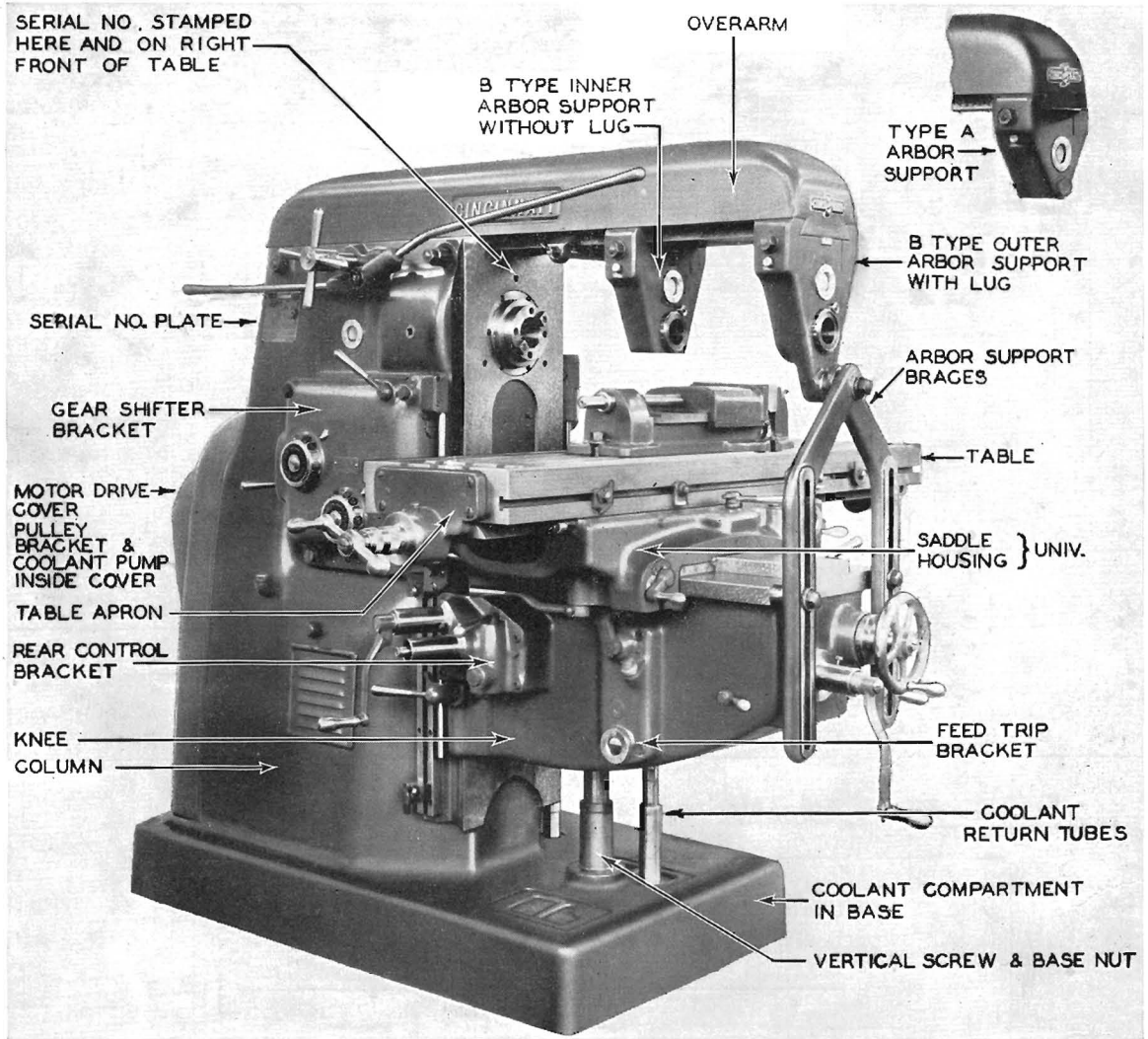

*Study* the two illustrations on this page to fix in your mind the names of the principal units and parts indicated. You will then have a better understanding of the service instructions which follow.

## INSTALLATION INSTRUCTIONS

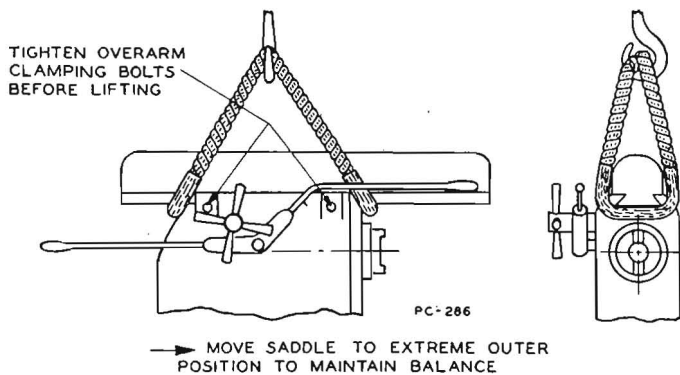

FIGURE 4

Figures Nos. 4 and 5 show the proper method of lifting both horizontal and vertical machines.

### Foundation:

Foundation requirements depend upon so many factors, such as speed of machine, balance, rate of metal removal, etc., that it is not feasible to devise exact foundation specifications which will fit all conditions.

The floor material is an important consideration. If the floor is made of re-

inforced concrete 6" or more in thickness, it is not necessary to build up a special foundation. If the ground floor is of timber construction and the distance from the solid ground to the floor is not too great, the best practice is to cut a hole through the floor and build a concrete foundation from the ground up to the floor line. (Use a standard 1-2-3 mixture.) If the floor is made of concrete overlaid with wood block or any shock-proofing material, the usual practice is to remove this material from its base and fill in with concrete up to the floor line.

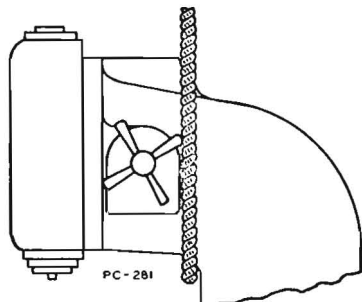

FIGURE 5

### Upper Floors:

If the machine is to be located on an upper floor or balcony, place it directly over a supporting beam or girder. There will be less possibility of vibrations being transmitted to it by other machines.

### Leveling:

After the machine has been moved to its proper location, it must be carefully leveled before grouting or bolting it to the floor.

For leveling machine tools, a sensitive, graduated tube spirit level is required, reading to 10 seconds per graduation (.0005" per foot) and provided with screw adjustment. Ordinary levels should not be used because they are not accurate

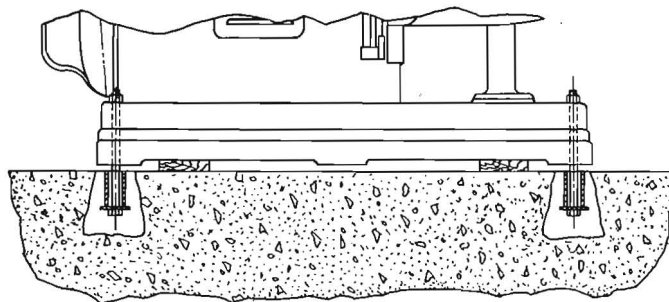

FIGURE 6

enough. The actual length of a level frame has no bearing on its accuracy. The glass tube alone determines its sensitiveness. A short level with a long tube is best. It costs less and can be handled or stored with less danger of damage.

Do not try to level a machine that has just been brought into the shop. Give it 24 hours to take on room temperature.



Do not expect a machine to remain level permanently. Buildings settle and floors warp. A periodic check-up is necessary to maintain utmost precision.

**Cleaning.** Do not move any machine slides before cleaning thoroughly, and oiling.

Use a good clean grease solvent. Rags should be used instead of waste because they leave no lint. Do not use an air hose for cleaning as it will drive grit and dirt into holes and under bearings. Use a stiff bristle brush to get into the corners.

When machine is thoroughly clean, rub clean machine oil over all the ways and make sure there is no grit left.

Prevent the formation of permanent stains by periodic cleaning after installation.

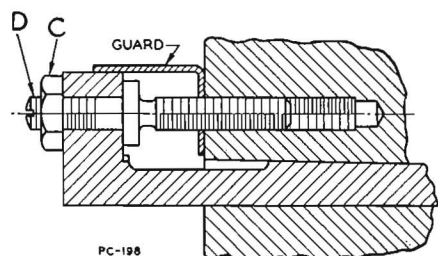

FIGURE 7

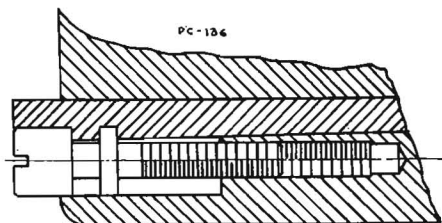

FIGURE 8

may cause scoring and unnecessary wear. Clean and oil bearings frequently to avoid undue wear on ends of gibs.

Adjustment of the headless type of gib, shown in Fig. 8, is the same as previously described except that no locking device is used. This type of gib is used on knee and also the saddle. There are two short gibs used on the knee. One is adjusted from top and the other from the bottom. The lower gib should always be adjusted first.

**Adjusting the Driving Clutch.** The clutch for these machines is self-compensating within certain limits, thereby eliminating the necessity for adjustment until the wear exceeds these limits. Nut "B" Fig. 9, regulates the allowance for the self-compensating effect, or wear; which is about .020" when the clutch is new or after it is adjusted.

## ADJUSTMENTS

**Adjusting the Gibs.** Two types of gibs, shown in Figs. 7 and 8, are used to take up wear between sliding units of these machines. The amount and method of adjustment, however, is the same for each type.

To adjust a gib of the type shown in Fig. 7, proceed as follows:

1. Loosen nut "C".
2. Turn screw "D" in a clockwise direction and follow up with nut "C" until movement of slide is tight.
3. Turn screw "D" in a counter-clockwise direction until slide is free to move without undue exertion.
4. Lock nut "C" in this position.

A certain amount of judgment or "feel" is necessary to know when slide movement is correct. Too tight an adjustment of gibs squeezes oil film out of sliding ways and

The position of nut "A" determines the force transmitted by the spring to the clutch plates, and therefore determines the load which the clutch will carry. Nut "A" is set by our assemblers to obtain the full capacity of the spring; therefore it should not be moved within the life of the clutch.

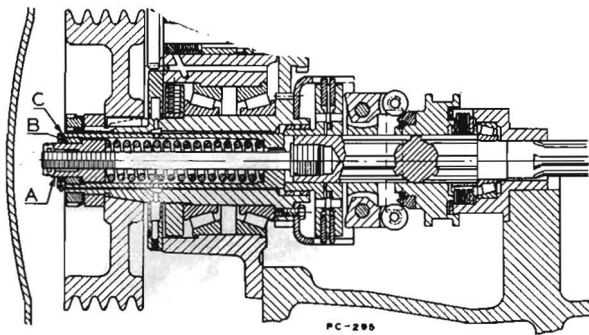

FIGURE 9

Section Through Driving Clutch

To make the adjustment to insure proper clutch engagement, proceed as follows:

1. Push up the starting lever.
2. Open the door over the pulley bracket unit.
3. Remove the cotter pin through nut "B".
4. Turn nut "B" in a clockwise direction until it touches nut "A", then back it away about two notches.
5. Replace the cotter pin.

The clutch may be worn to such an extent that nut "B" cannot be turned in a clockwise direction, as stated in step No. 4. If this condition exists, do not try to force it; just back it away the required amount. If, after making the adjustment, the spindle rotates slowly with the starting lever in the stop position, nut "B" has been backed away too far, allowing the clutch plates to contact with the clutch finger holder in the stop position. When the clutch is properly adjusted, spring sleeve "C" will move out about .020" when the starting lever is pushed up.

**Adjusting the Rapid Traverse Clutch.** If the rapid traverse clutch is slipping, it must be adjusted before undue wear takes place. Proceed in the following manner:

1. Remove the small brass cover "D" which is held to the feed box by four  $\frac{1}{4}$ " hex head cap screws. (These instructions are also engraved on this cover.)
2. Loosen screw "A".
3. Pull out lock pin "B" and turn adjusting yoke "C" towards the plates. (The threads are right hand.)
4. See that lock pin "B" is engaged in one of the holes. Tighten screw "A".
5. Replace cover "D".

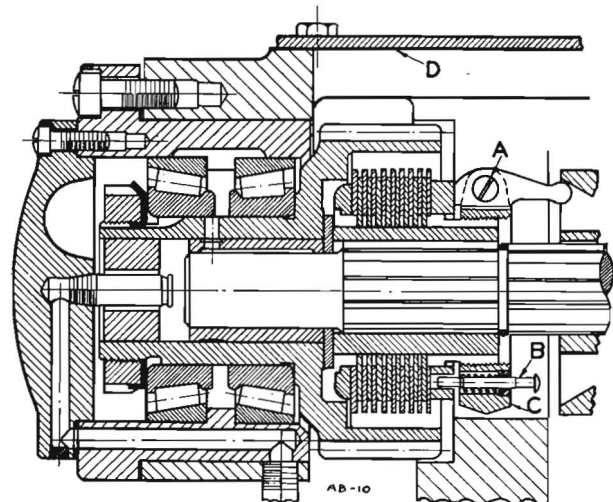

FIGURE 10

Section Through Rapid Traverse Clutch

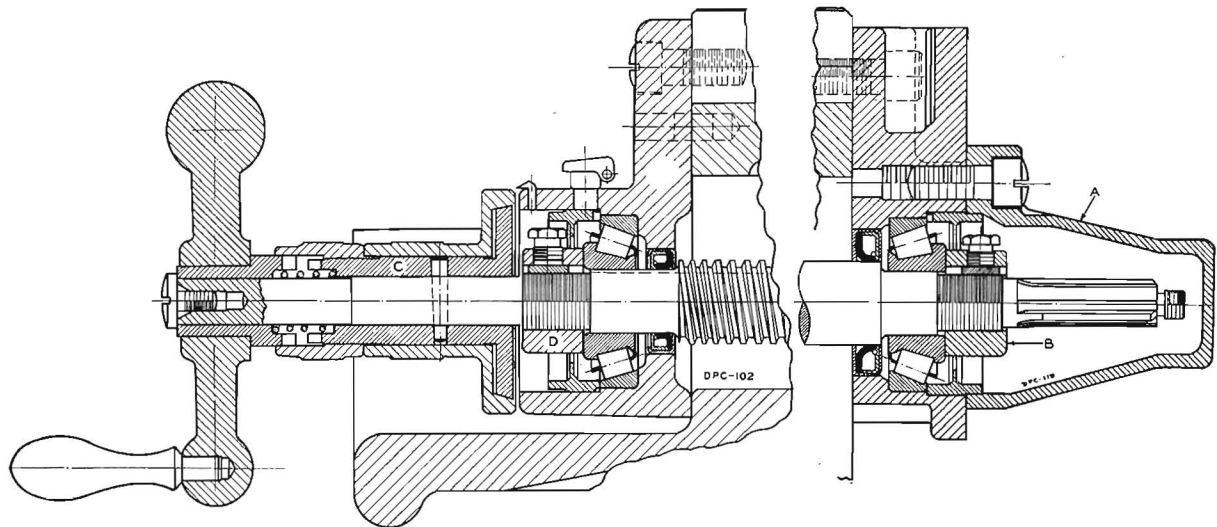

FIGURE 11

Section Through Right and Left Hand Table Aprons

## DISMANTLING INSTRUCTIONS

### Removing Table Lead Screw:

1. Remove cover over end of lead screw at right-hand end of table. "A" in Fig. 11.
2. Remove lock nut on lead screw. "B" in Fig. 11. After loosening hexagon head lock screw in nut, tap nut to loosen shoe in lock nut.
3. Remove four screws holding right-hand table apron to table. Tap apron to break joint and slide apron off end of lead screw. Two  $\frac{1}{2}$ " straight dowel pins locate apron to the table.
4. Remove ball crank, spring, dial, and dial lock nut on left-hand end of table.
5. Remove taper pin from clutch "C", and remove clutch. This will expose lock nut on lead screw "D". Remove this lock nut in the same way as described under item 2.
6. Remove four screws holding apron to table, and remove apron by tapping. This is same construction as the other end of table.
7. Now the lead screw may be run out of nut from left to right. This may be done by hand, or by power. End of lead screw must be supported if power is used.

NOTE: When re-assembling, adjust lock nut on left-hand end of lead screw first. Do this so that end of dial on lead screw has  $\frac{1}{32}$ " clearance between it and end of boss on table apron. Any further adjustment should be done with lock nut on right-hand end of table.



### Removing Table:

1. After removing lead screw as explained, remove table gib. This is a headed type of gib as shown in Figure 7, page 8.
2. Table may now be removed from either end. Table may be slid onto any suitable supports. If a crane is used, make sure eyebolt is tight and in the center of table.

### Removing Universal Housing:

1. Remove lead screw and table as explained.
2. Remove four hexagon head ( $1\frac{1}{16}$ " across flat) clamp screws and wedges under them. See Figure 12.
3. Lift housing straight up. It is important to lift evenly, otherwise clamp bolts will wedge in the saddle.

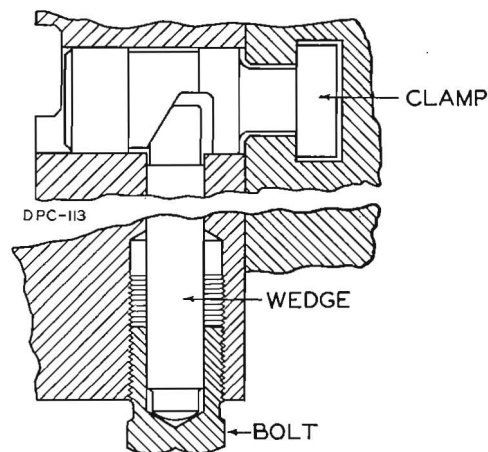

FIGURE 12

Section Through Clamp Bolt, Wedge and Screw

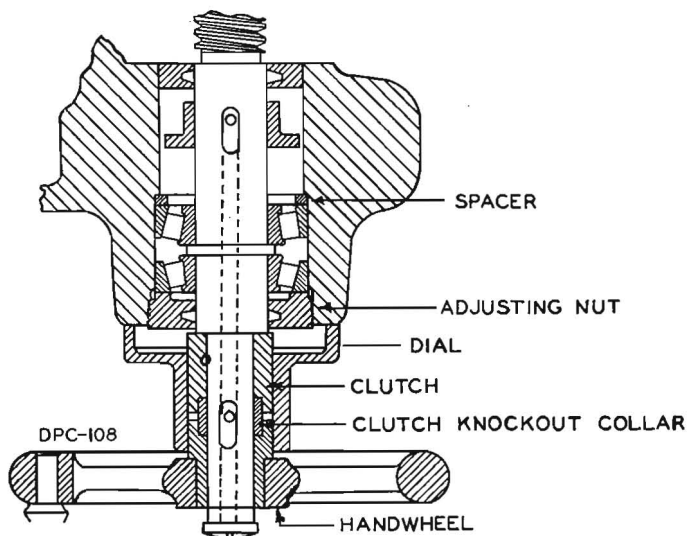

FIGURE 13

Section Through Cross Screw Bearings

### Removing Cross Screw

1. Remove hand wheel and dial. Figure 13.
2. Remove headless screw in knock-out collar and remove collar.
3. Drive taper pin out of clutch and remove clutch.
4. Remove two  $\frac{1}{4}$ " headless set screws holding adjusting nut in place.

5. With a face spanner wrench, remove adjusting nut, which has right-hand threads.
6. Replace clutch, taper pin, and hand wheel.
7. Clamp saddle.
8. With handwheel, remove cross screw. Screw may be hard to move until roller bearing cups are free of casting. Turn cross screw clockwise to remove.

NOTE: If cross feed (safety) coupling (Key No. 1075, page 56) is broken it is accessible at right side opening after cross feed screw and rear control bracket are removed. Remove expansion plug at left end and  $1\frac{3}{8}$ " diameter plug (tapped  $\frac{3}{8}$ "—16 as aid for removal) at right end; then tap cross feed trip shaft toward right out of knee before trying to remove rear control bracket. Fit broken pieces of coupling together to make certain all have been taken out.

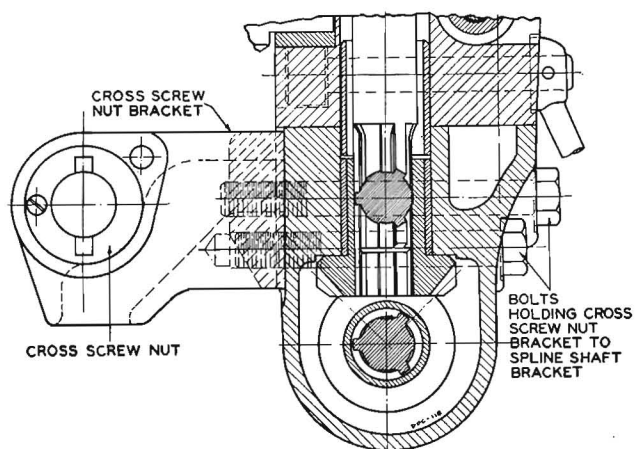

FIGURE 14

Section Through Spline Bracket and Cross Screw Nut and Bracket

### Removing Cross Screw Nut Bracket:

1. Remove cross screw.
2. Remove two hexagon head screws, heads of which are outside of spline shaft bracket on saddle, on right hand side of knee. See Figure 14.
3. Cross screw nut bracket will then fall into coolant drain compartment of knee.
4. Move saddle back toward column and bracket may be picked out. Coupling which connects cross feed power drive to cross screw may also fall into coolant compartment. See Figure 15.

NOTE: When re-assembling cross screw nut bracket to the spline bracket, use G. E. 880 sealing compound, or its equivalent around cored hole for coolant return.

When re-assembling cross screw, have saddle in a position toward front of knee. Slip coupling on splined section of cross screw, and then match keyways of the coupling with keys of power drive shaft in knee. Turn cross screw until coupling can be slipped over both sets of keys. Make sure spacer (Figure 13, page 11) is in place.

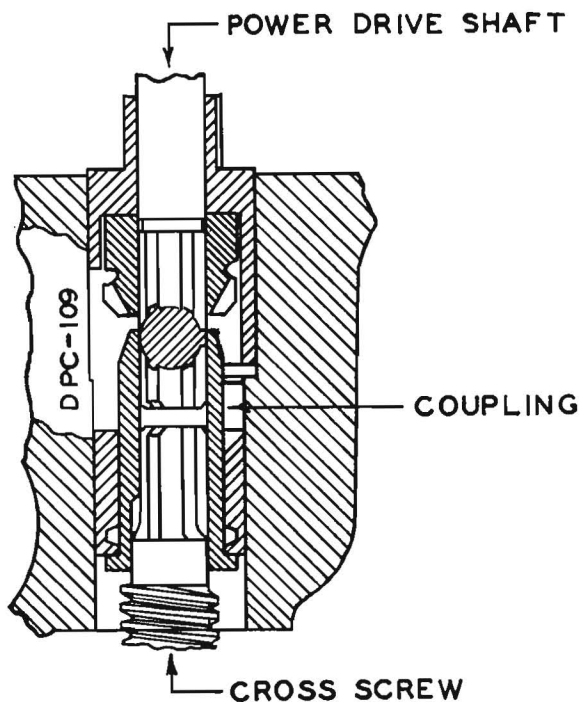

FIGURE 15

Section Through Cross Screw Coupling and Power Drive

Cross screw nut bracket is keyed against thrust of cross screw. It may be necessary to adjust bracket vertically to make cross screw move freely. Move saddle to its front or rear position, loosen two holding screws and allow bracket to find its central position. Tighten holding screws while turning cross screw hand wheel back and forth.

### Removing Saddle: (Plain and Universal)

1. Remove lead screw, table, and gib.
2. Remove three saddle gibs. These are headless type of gibs. See Figure 8, page 8.
3. Remove Cross Screw Nut Bracket (see above) and remove front control Power Feed Lever.
4. With a suitable rope sling around saddle, slide saddle over end of knee.

NOTE: When re-assembling saddle to knee, always adjust center saddle gib first.

## Removing Spline Shaft Bracket:

1. Set saddle in a position on knee so that end of spline shaft clears bevel gear in bracket.
2. Remove four hexagon head bolts which hold spline shaft bracket to saddle. Two of these are dowel screws which locate bracket to the saddle.

NOTE: Spline shaft bracket moves straight down on Nos. 3 and 4 machines. On Nos. 1 and 2 machines, bracket moves down at a slight angle toward front of machine.

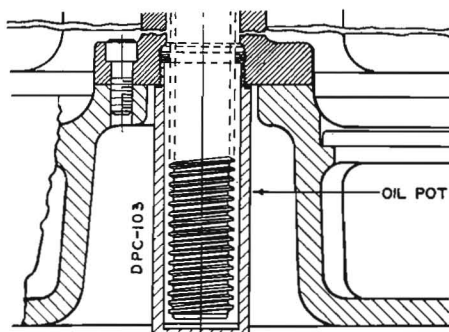

FIGURE 16

Section Through Oil Pot

## Removing Vertical Screw:

1. Run knee to its highest position.
2. Block up between bottom of knee and base of column.
3. Remove two one-half inch hollow head cap screws that fasten vertical screw base nut to base of column. See Figure 16.
4. Run vertical screw nut up to its highest position.
5. Remove round plate on top of knee. This will expose lock nut on top of Vertical screw. See Figure 17.
6. Remove set screw in lock nut on vertical screw. See Figure 17.
7. Tap vertical screw through gear, while holding screw and base nut from underneath.

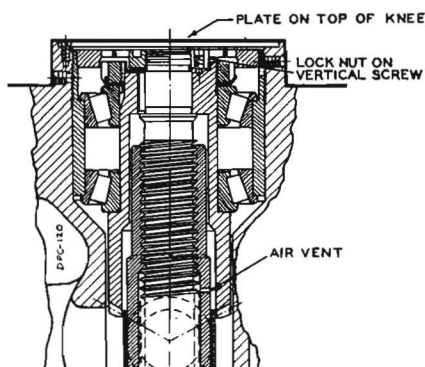

FIGURE 17

Section Through Top of Vertical Screw

## Lubrication Note:

It is important that the correct lubricant be used before machine is again put in operation, after the re-assembly of any unit requiring the drainage of the oil.

Vertical screw is lubricated by running knee all the way down. The vertical screw then displaces the lubricant in oil pot causing level to rise and lubricate threads of screw. See Figure 16. While vertical screw is removed from machine, it would be well to inspect, and refill oil pot if necessary. Proper lubricant for this is: seven parts heavy unfiltered oil (Vacuum Oil 600-W or Standard Oil 650-W) to one part Sturaco extreme pressure base, 250 seconds Saybolt at 200 degrees F. (Stuart Oil Co.) Fill oil pot to within  $\frac{1}{4}$  inch of its top.



### Removing Change Gear Bracket:

1. Loosen brass union between cover on change gear bracket and the knee proper. See Figure 18.
2. Remove vertical spline shaft and rapid traverse control rod as explained in removing Feed Box.
3. Remove four one-half inch hollow fillister head screws which hold change gear bracket to knee.
4. Tap bracket to break seal, and pry bracket straight out. Two  $\frac{3}{8}$  inch straight dowel pins locate bracket to knee.

NOTE: When re-assembling change gear bracket to knee and the cover on bracket, clean surfaces thoroughly and use G. E. 880 or its equivalent as a seal to prevent oil leaks.

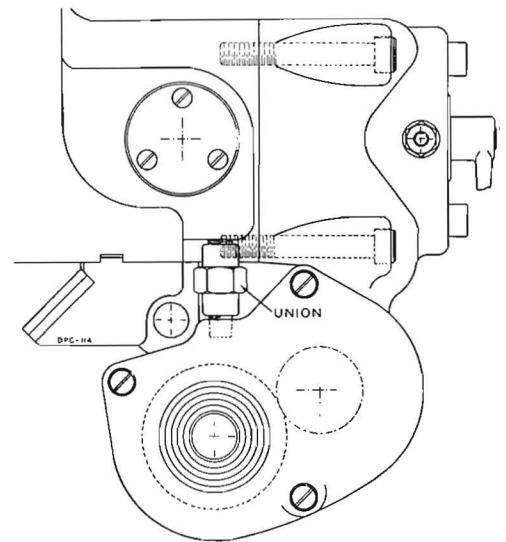

FIGURE 18

View of Bottom of Change Gear Bracket

### Removing Lubricant Pump in Knee:

1. Remove three fillister head screws through plate and pump. See Figure 19.
2. Tap or turn pump to break seal.
3. Pry or tap pump body out of knee. Pump body is a push fit in knee casting.

NOTE: When re-assembling pump body to knee, seal the joint between pump body and knee.

### Lubrication Note:

It is important that the correct lubricant be used before machine is again put in operation after reassembly of any unit requiring drainage of the oil.

Proper oil for lubrication of the knee is a medium machine mineral oil. Viscosity 190 to 200 seconds Saybolt at 100 degrees F. (Standard Oil Co. "Red Engine Oil" or any oil company's equivalent.)

Splash and spray system lubricates the knee. Oil is carried from a central catcher to remote parts by copper tubing. See illustration of Oil Circuit in Knee. Figure 20, oil drain, filler cap and oil sight gage are also shown in the illustration.

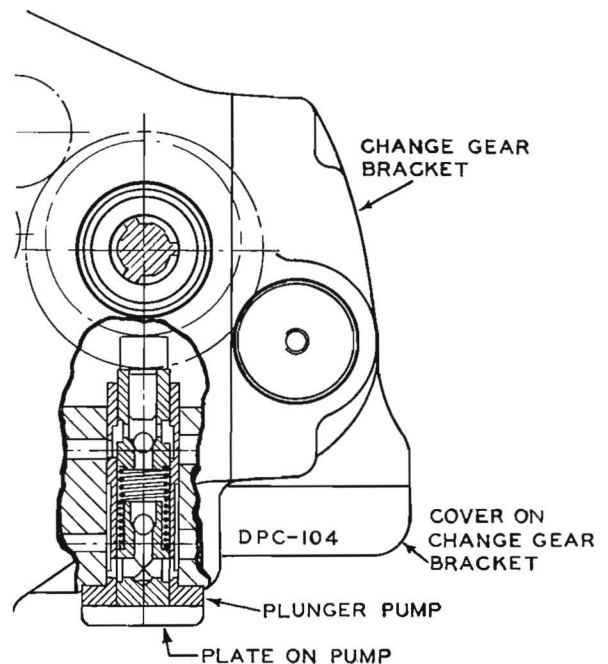

FIGURE 19

Section Through Pump in Right Hand Side of Knee

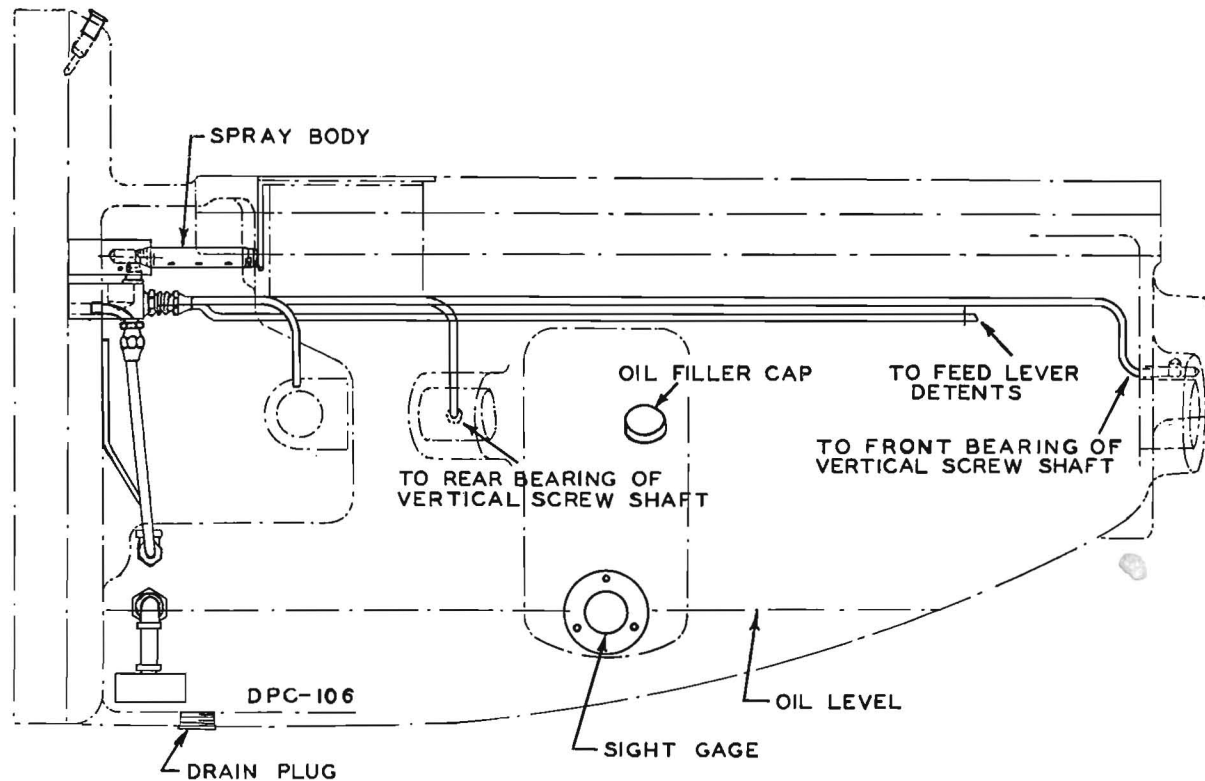

FIGURE 20  
Oiling Arrangement of Knee

**Removing Knee:**

1. Remove table, housing-saddle, vertical screw and change gear bracket as explained in foregoing instructions.
2. Remove two taper gibs. These are headless type of gibs as shown in Figure 8, page 8. One gib is at top of knee guide and the other is at the bottom of the guide.

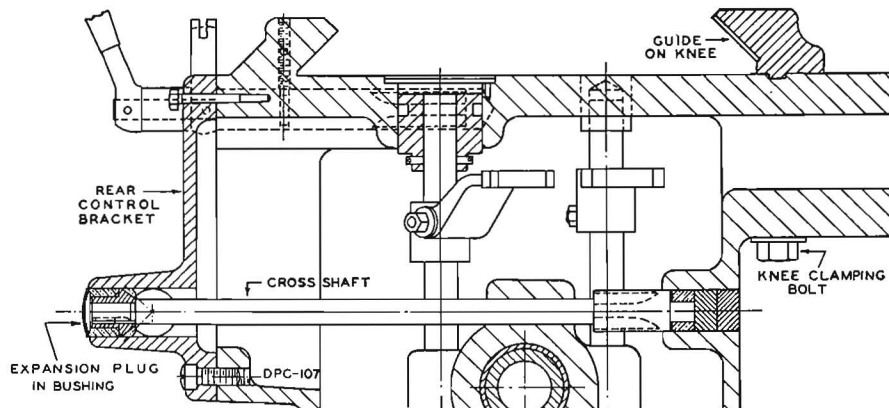

FIGURE 21  
Section Showing Knee Clamping Screw and Guide

3. Remove knee clamping bolt on right-hand side of knee. Figure 21.
4. Sling a rope around knee to balance knee and remove six three-quarter hollow head fillister screws which hold knee guide to knee. Two upper screws in guide go through from the front.
5. Remove knee guide by tapping on top.

**NOTE:** Handle guide carefully. If handled carelessly it may break through clamping saw slots.

When re-assembling knee guide to knee, make sure short hollow head screw is used in hole closest to the eccentric pump gear. If longer screw is used the end of screw will lock the eccentric pump gear.

### Removing Coolant Pump:

1. Open motor door cover. This will uncover pulley bracket and coolant pump.
2. Disconnect two unions, one on either side of pump. See Figure 22.
3. Remove five three-eighths hollow head fillister screws and lock washers.
4. Tap pump body to break seal.
5. Pull pump straight out.

**NOTE:** When re-assembling pump to pulley bracket, clean both surfaces thoroughly and re-seal with G. E. 880 or its equivalent to prevent coolant water leakage and to prevent air being sucked into pump system. In regular operation, it is well to clean strainer on suction line of pump once a week. This will prevent air being taken into system and causing coolant to spurt intermittently from supply pipe, and also to prevent coolant water from foaming. See Figure 22. If through evaporation of water, or any other reason the oil content of the water is excessive, coolant will foam. The addition of kerosene will usually correct this condition.

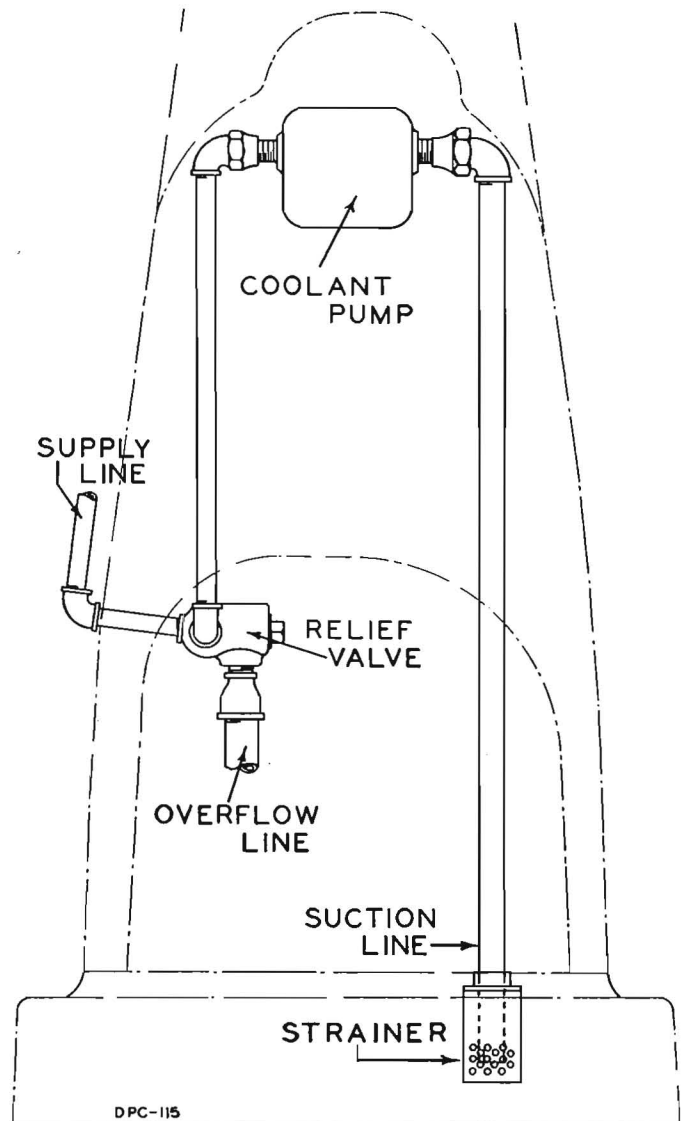

FIGURE 22

Coolant Pump, Relief Valve and Intake Pipe

### Removing Pulley Bracket:

1. Drain oil from column.
2. Remove driving belts or chain.
3. Remove two hexagon head tapered pins and hexagon head bolts holding pulley bracket to column.
4. Engage spindle starting lever, and leave engaged until pulley bracket is re-assembled to machine. If this precaution is not taken, it will be quite a problem to assemble large driving flange over the three tangs of clutch plates.
5. Remove pulley bracket by pulling straight out.

**NOTE:** It is not necessary to remove coolant pump to remove pulley bracket.

When re-assembling pulley bracket to column, clean both surfaces thoroughly and re-seal with G. E. 880 or its equivalent to prevent oil leaks.

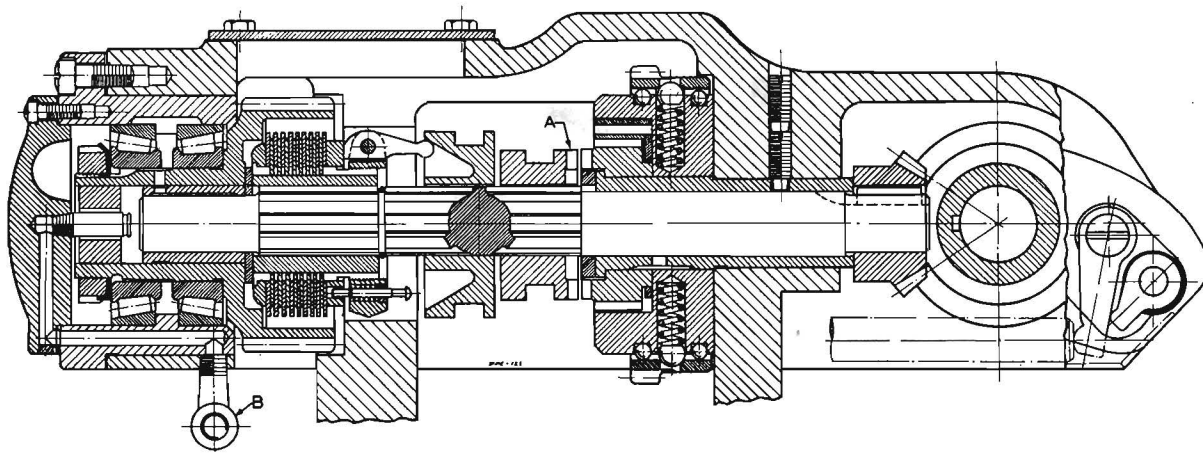

FIGURE 23

Section Through 5th Feed Shaft and Rapid Traverse Clutch

### Removing Feed Box:

1. Remove flat plate on top of feed box. This will expose top of vertical spline shaft and rapid traverse control rod.
2. Remove ring spring which holds spline shaft in position.
3. Loosen telescopic tube which is screwed into change gear bracket.
4. Lift out spline shaft.

5. Remove rapid traverse control rod.
6. Tie up the telescopic tubes, using a wire through tubes and feed box, tie up close to feed box.
7. Remove one-half inch headless screw from top center of feed box. Put an eyebolt in this hole and hook up to hoist.
8. Remove bolts holding feed box to column. Remove feed box by prying straight out. Two  $\frac{1}{2}$ " straight dowel pins locate feed box to column.

**NOTE:** When re-assembling, clean surfaces thoroughly and re-seal with G. E. 880 or its equivalent to prevent oil leaks. In re-assembling feed box to column, put spindle starting lever in engaged position. Set Clutch "A", Figure 23, so that clutch teeth are together. In other words, clutches should be set tooth on tooth. This will prevent pin in clutch link from hitting interference block in feed box and bending clutch link. Make sure oil tube at rear of feed box enters the street ell "B" in feed box.

### Removing Gear Shifter Bracket:

1. Feed box must be removed.
2. After feed box has been removed, the feed change shaft is exposed. This shaft extends out from machined surface against which feed box is fitted. On Nos. 1 and 2 machines this shaft must be removed before shifter bracket can be taken off. The end movement of this shaft is limited by a lever which fits in groove in the shaft. Lever is held in place by a  $\frac{3}{8}$ " wedge bolt. Loosen nut and tap thread end of wedge bolt to loosen. Slide lever to the left. Remove feed change shaft.
3. Remove four  $\frac{1}{4}$ " fillister head screws from small bracket at upper end of feed and speed control rod and fastened to front side of gear shifter bracket. Two No. 4 taper pins locate this bracket to gear shifter bracket. Pry bracket out and lift up. Feed and speed control rod will come out with bracket.
4. Remove  $\frac{1}{2}$ " headless screw from top center of gear shifter bracket and replace with an eyebolt. Hook up to a hoist.
5. Remove bolts holding gear shifter bracket to column. Pry out to break seal. Pull bracket out at top while lifting with crane, after dowel pins are free of locating holes.

**NOTE:** Clean surfaces thoroughly and re-seal before re-assembling.

### Removing Hand Feed Worm Box: (Vertical Machines Only)

1. Lock the head in suitable position with clamp. This is a safety precaution.
2. Support box in suitable rope sling.
3. Remove hexagon taper pin and four hexagon head bolts holding worm box to column.
4. Break seal and remove box by pulling straight out.

NOTE: Clean and re-seal when re-assembling.

### Removing Power Feed Worm Box: (Vertical Machines Only)

1. Lock head in suitable position. This is a safety precaution.
2. Remove cover on rear top of worm box directly over vertical spline shaft. Screw  $\frac{3}{8}$ " eyebolt in one of exposed holes.
3. Remove cover at rear and under worm box.
4. This exposes coupling between worm box and vertical spline shaft. Move ring spring and remove set screw in lower half of coupling.
5. Support worm box with rope sling around handwheel in front of box and a hook through eyebolt.
6. Remove hexagon head taper pins and five hexagon head bolts holding worm box to column.
7. Break seal and remove worm box by pulling straight out.

NOTE: Clean and re-seal when re-assembling.

### Removing Vertical Spindle:

1. Remove lock ring spring on upper end of spindle. See Fig. 24.
2. Remove dust cap and cover on top of spindle.
3. This exposes upper adjusting nut on spindle. Loosen lock screw and tap nut to loosen shoe in lock nut and remove nut. Turn counter-clockwise to remove.
4. Remove key between spindle and roller bearing cone with a pair of long nosed pliers.
5. Move vertical head to its highest position and clamp in this position.

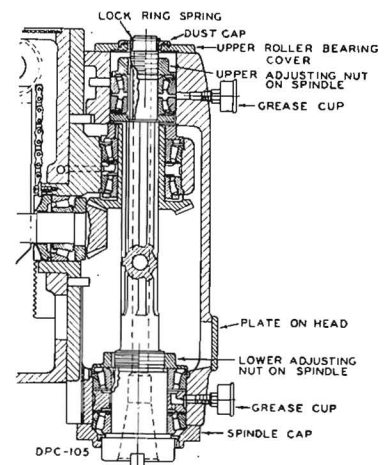

FIGURE 24

Section Through Vertical Spindle



6. Remove plate on front of head, and cap over spindle nose.
7. Turn spindle until lock screw in lower nut is accessible.
8. Loosen lock screw with a socket wrench and tap nut to loosen shoe.
9. Block up between end of spindle and table.
10. Unscrew nut until nut is clear of threads on spindle.
11. Remove key between spindle and roller bearing cone with a pair of long nosed pliers.
12. Lower knee so that end of spindle is  $\frac{1}{4}$ " from supporting block. Tap spindle on top until lower end hits block. Repeat this until spindle is free of the one top spindle bearing.
13. After removing this bearing, pull out upper retainer and then remove second bearing cone and key which locates bearing to spindle. Now spindle is ready to be removed.  
  
Mark one key of spindle and mating keyway in bevel gear so that spindle may be put back the same way.
14. Lower knee to its lowest position. Hold spindle up and run saddle and table to its front position and remove spindle.

### Lubrication Note:

(High Speed Machines) It is very important to use proper lubricant for the spindle bearings. Use limited amount only, one turn of grease cup once a week.

Correct grease is a medium sponge, short fibre, sodium soap base. (Standard Oil Co. of Indiana "Superla 2X" or Vacuum Oil Co. "Medium Sponge Grease".)

This information is also printed on caps of grease cups.

When spindle is adjusted correctly and proper amount of above grease is used, spindle will run at a temperature of 135° to 145° F. at high speed, after a one-hour period.

NOTE: In re-assembling spindle to head, assemble lower set of bearings first, after which upper bearings, keys, retainer, etc. may be more readily put into head.

### Removing Vertical Head:

1. Remove spindle as explained.
2. Lower vertical head to its lowest position, and clamp. Also support with block.

3. Remove sheet metal cover over counter-weight compartment on top of column. This exposes counter-weights.
4. Support one counter-weight. Lift weight to provide slack in chain.
5. Remove pin in first link in chain supporting counterweight and lower counterweight until it rests on bottom of compartment.
6. Remove second counterweight from chain in the same way.
7. Support head with a suitable sling and with two eyebolts screwed into top of head.
8. Remove three headed type of gibs.
9. Remove two head guides. NOTE: Sliding wedge gib is fitted in left-hand guide on head.
10. Lift head to its highest position and pull head straight out.

### Removing Horizontal Spindle:

1. Remove feed box and gear shifter bracket as previously explained.
2. Remove cap "A" on rear of spindle and cap "F" on front of spindle. See Figure 25.
3. Remove two spindle keys "I" and fasten a rectangular bar in key slot for leverage.
4. Remove locknut "D" from spindle. All lock nuts on spindle are the shoe type.

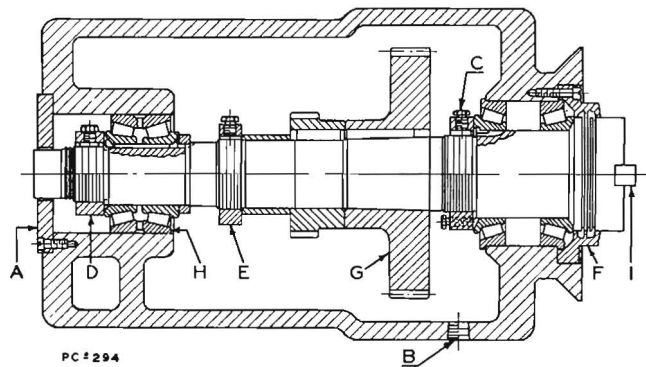

FIGURE 25

Section Through Horizontal Spindle  
Medium Speed Machine

5. Remove key which locates roller bearing cone to the spindle.
6. Using a slender steel rod, drive retainer and one bearing out of column. This must be done by driving on retainer "H" from the inside of column.
7. Remove second rear bearing from spindle using same method as above.
8. Remove lock nut "E" from spindle.
9. Loosen lock nut "C" and back it off until it tightens against face gear "G". Tap face gear to break it loose. Face gear is a fit on taper of spindle and may be hard to break loose.

10. Slide face gear to rear of column and remove lock nut "C" and key which locates roller bearing cone to spindle.
11. Tap spindle from the rear, meanwhile taking weight off of the spindle, by holding up face gear in some manner. By removing overarm and the sheet steel cover on top of column between overarm ways, a thin rope sling may be placed around face gear and hooked up to a hoist.

NOTE: In order to remove face gear "G" from column, it is necessary to remove back gears and back gear shaft. See illustration of front of column, page 23.

### Adjusting Spindle Bearings: (Horizontal Machines)

1. Remove pipe plug "B". See Figure 25.
2. Remove two spindle keys "I".
3. Loosen lock nut "C". Tap socket wrench to loosen shoe in lock nut.
4. Set spindle reverse lever in neutral position.
5. Clamp a bar in key slot across spindle nose for leverage.
6. With the socket wrench in position, turn spindle counter-clockwise to loosen bearings, and clockwise to tighten bearings.
7. Re-tighten hexagon head lock screw in lock nut "C".

NOTE: When taking up the roller bearing adjustment, rotate the spindle several turns to permit rolls of the bearing to roll against the rib of the inner race. Never drive bearing or front of spindle to accomplish this.

The rear bearing of spindle can be adjusted in the same way, but it should not be necessary to adjust this bearing at any time. On High Speed Machines, spindle should have .0005 end play. This can be measured by using an indicator on end of spindle nose and lightly tapping spindle from front end and then rear end and reading indicator. Spindle will run at a temperature of 135° to 145° F. when properly adjusted and run at its highest speed. This temperature should be tested with a thermometer in one of the screw holes in spindle cap "F", Figure 25, page 21.

### Adjusting Spindle Bearings: (Vertical Machines)

Same procedure is followed as for horizontal machines except for removal of plate on head, Figure 24, page 19.

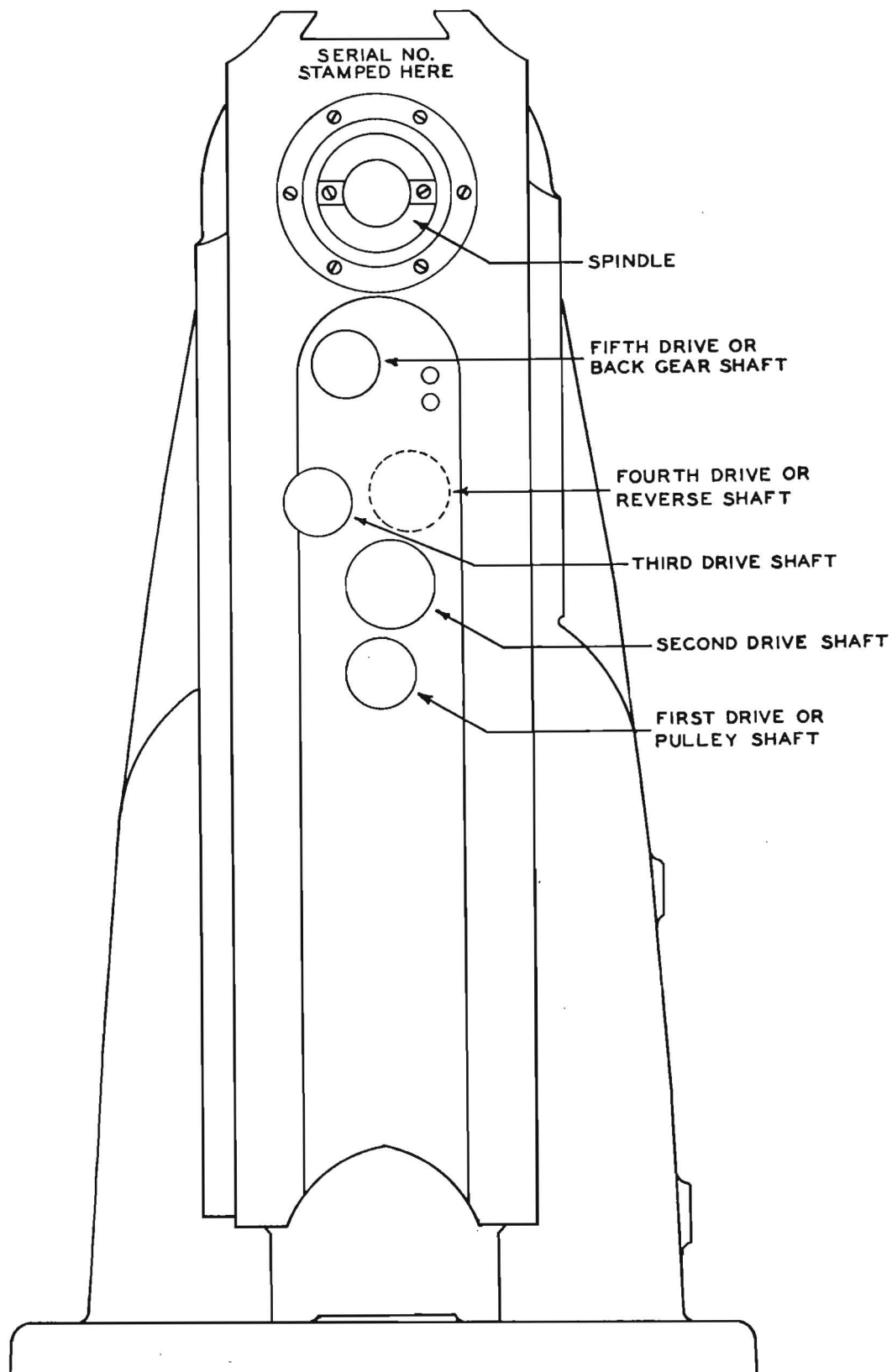

Diagrammatic view of front of column showing position of spindle and shafts

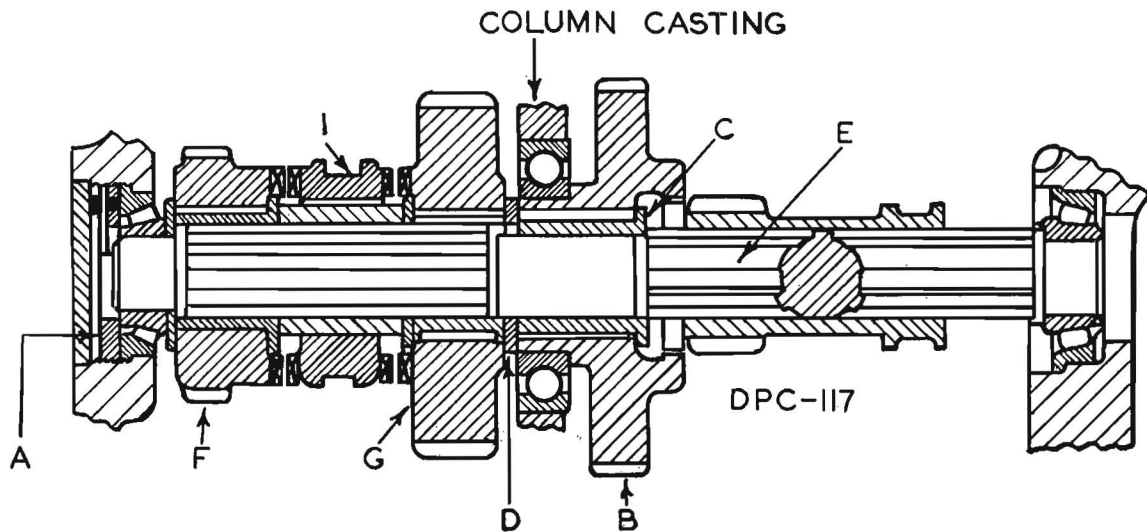

FIGURE 26

Section Through Back Gear Shaft High Speed Machine

### Removing the Back Gear Shaft:

1. Remove feed box and gear shifter bracket as previously explained.
2. Remove pulley bracket as explained.
3. Remove link connecting clutch shifter fork and the lever on starting lever shaft.
4. Remove plugs at both ends of shaft. See fifth drive or back gear shaft illustration on page 23.
5. Remove adjusting nut "A" at rear end of shaft. This is a split type of lock nut. See center illustration Figure 27. On No. 2 machines only. No. 3 machines employ type of lock nut shown at top illustration Figure 27.
6. Tap front end of shaft lightly until face of large helical gear "B" is against column casting. See Fig. 26. Now tap shaft at rear. This will move roller bearing on rear of shaft far enough to permit keys in shaft to disengage keyways in face of flange of sleeve "C". Sleeve "C" must be turned to line up keyways in hole of sleeve with keys on shaft, so that sleeve will slide over shaft. Thrust of roller bearing adjustment is through the length of sleeve, keys, etc.
7. Tap front of shaft until rear roller bearing cup is free of casting.
8. Now remove front roller bearing cone from shaft.
9. Tap front of shaft, meanwhile be sure keyways in sleeve are lined up properly with keys of shaft. Washer "D" must have keyways lined up when it reaches key section "E" of shaft. This washer is the most difficult to line up, so a little care must be taken at this point.
10. Now shaft may be removed.

**NOTE:** When re-assembling, parts must be replaced in the same position as original assembly. Otherwise, there is a possibility of changing distance between clutch teeth of gears "F" and "G". This will cause trouble in shifting of clutch "I".

Be sure to turn sleeve "C" on shaft so that keyways in face of sleeve are engaged with keys on shaft.

### Removing Other Drive Shafts:

1. Remove feed box, gear shifter bracket, and pulley bracket as previously explained.
2. Run knee to its lowest position.
3. Remove plugs in front of column.
4. Remove lock nuts on ends of shafts.
5. Pins in various gears must be removed. These pins can readily be seen by inspection of gear mounting.
6. Proper procedure for removal of shafts can be seen on inspection. Three types of lock nuts are shown in Figure 27.

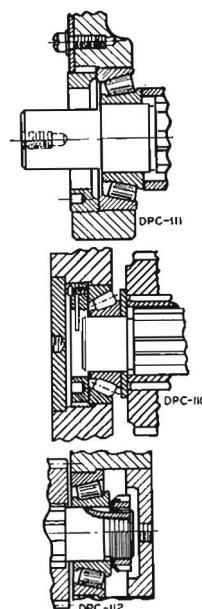

FIGURE 27

Three Types  
of Locknuts

### Removing More Than One Unit At One Time:

Saddle and table can be removed from machine as a unit by leaving saddle and table together and following instructions for removal of saddle. The same is true of universal housing, saddle and table.

The knee, saddle, and table may also be taken off as a unit by following instructions for removing the knee. Care must be taken to make sure unit as a whole is properly balanced.

Usually a combination of units are lifted with two eyebolts in center tee slot of table, or with a rope sling around table if lead screw is protected.

### Removing the Overarm:

1. Loosen two overarm clamping nuts. See illustration page 6.
2. Put a rope sling through cored holes in top of overarm so that overarm will be properly balanced.
3. Slide overarm straight out of its ways.

**NOTE:** When re-assembling overarm to column, balance overarm in rope sling and bring overarm to approximately correct height. Start overarm into ways. Using a square on face of column, line overarm up with the blade of square by raising or lowering overarm as required. Do not depend on eyesight for above. Use a square. Overarm ways of column can be broken if care is not taken in lining up overarm.



### Removing Rear Control Bracket:

1. Drill and tap hole in center of  $1\frac{1}{4}$ " expansion plug in bush, (See Figure 28) and remove plug.
2. Drive shaft out from left to right. This will remove two plugs on right end of shaft.
3. Turn spline shaft from knee through spline shaft bracket on saddle, so that keys on spline shaft clear cross shaft.
4. Remove four filister head screws and two hexagon head taper pins.
5. Break seal by tapping, and remove bracket by pulling out at same angle as shafts.

NOTE: When re-assembling, clean both surfaces thoroughly and re-seal with G. E. 880 or its equivalent to prevent oil leaks.

$1\frac{1}{4}$ " expansion plug will have to be replaced with a new one. These plugs can usually be obtained from motor car supply houses.

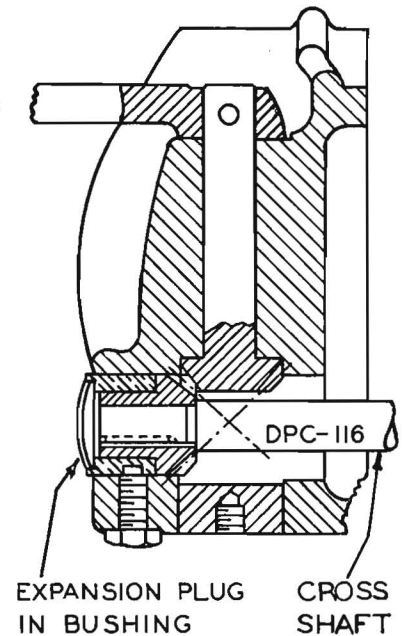

FIGURE 28

Section Through Rear Control Bracket

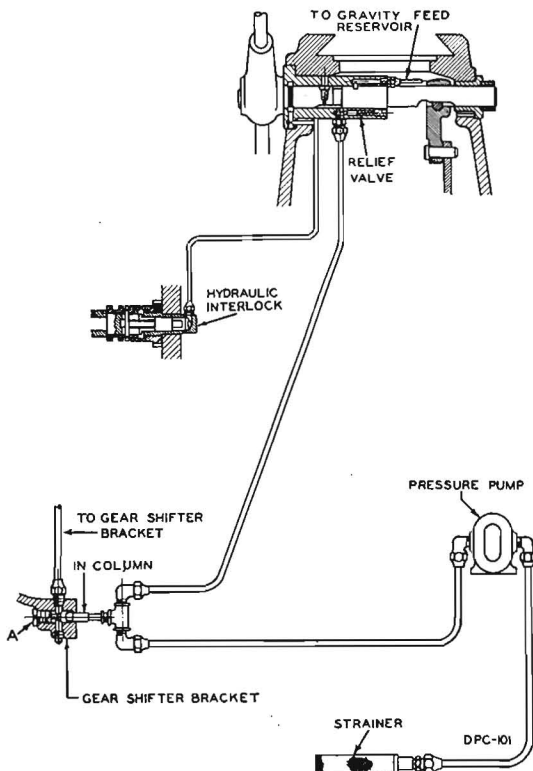

FIGURE 29

Hydraulic Circuit in Column

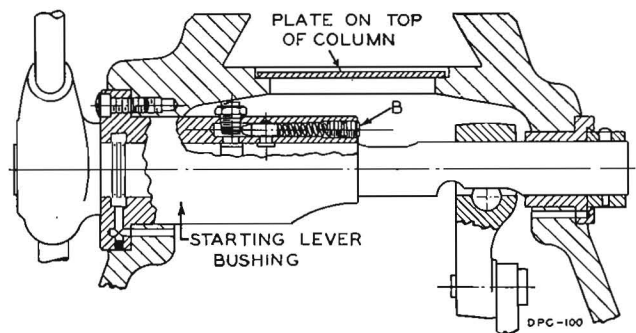

FIGURE 30

Section Through Relief Valve and Starting Lever Bushing

### Setting the Oil Pressure of Pump in Column:

1. Remove screw plug "A", Figure 29, at bottom, rear of gear shifter bracket. Put at least a 500 lb. hydraulic gauge in this connection. This is a  $\frac{3}{4}$ -16 R. H. tapped hole and requires a special fitting, or drill and tap  $\frac{1}{4}$ " pipe thread through plug "A" for gauge.
2. Pull overarm forward to uncover plate on top of column, Figure 30. Remove this plate.

3. Remove first of two  $\frac{3}{8}$ " hollow headless set screws in the end of starting lever bushing at "B", Figure 30.
4. Turn second screw at "B", Figure 30, in to increase pressure. Pressure should be 290 lbs. to 310 lbs. Replace locking screw.

### Removing the Pressure Pump from Column:

#### Nos. 3 and 4 Machines

1. Remove pulley bracket as explained elsewhere.
2. Remove nut "B" and "A", see Figure 9, page 9, and sleeve and spring.
3. Remove clutch plates and discs.
4. Remove two springs on clutch engagement fingers.
5. Remove clutch finger carrier and clutch spreader spool. Finger carrier is located on shaft by a flatted pin locked in place by a cotter pin. A one-half inch hollow hexagon head bolt clamps carrier to shaft.  
This will provide enough space to remove the pump.
6. Disconnect strainer or intake line at the pump, and the discharge line at pump.
7. Remove two hexagon head bolts through small flatted plate on pulley bracket face of column.
8. Tap pump bracket out of hole in column.

#### Nos. 1 and 2 Machines

Procedure is the same except that discharge line is connected at the tee in column.

NOTE: When re-assembling, make sure locating pin in pump bracket enters hole in column. This dowel pin determines running clearance of gear on pump and its mating gear.

### Lubrication of Column:

The column of the machine is lubricated by the gear pump which also supplies pressure for hydraulic gear shift. Surplus oil through relief valve supplies oil to a chamber at the top of column, from which it is carried, through tubes, by gravity to spindle bearings and various other places. Parts in lower part of column are lubricated by a cascade of oil from overflow of the chamber at the top of column, and the splash from first drive shaft dipping into main column reservoir.

Proper oil for use in column is the same as specified for the knee; namely, Medium machine mineral oil. Viscosity 190 to 210 seconds Saybolt at 100 degrees F. (Standard Oil Co.'s "Red Engine Oil" or any oil company's equivalent.)

It is important to use proper oil in the column. Some oils leave a sludge in bottom of column and cause the intake strainer to collapse, thereby starving the pump and preventing the hydraulic gear shift from functioning properly. Keep oil level in column up to the threads in filler elbow. Drain and refill after first month of operation. Thereafter drain and refill with clean oil, while machine is idle, about twice a year, depending on operating conditions.

## HOW TO ORDER REPAIR PARTS

You will receive quicker and better service when ordering repair parts if you will follow the instructions below.

These six requirements are essential:

1. Correct and complete serial number of the machine. See paragraph "A".
2. Size and type of machine. See paragraph "B".
3. Description or name and number of part. See paragraph "C".
4. Amount wanted.
5. Urgency. See paragraph "D".
6. How to ship. See paragraph "E".

### Paragraphs

A—Serial numbers on these machines may be found in three places, namely, on Horizontal Machines—stamped on the front face of the column just below the overarm bearing. At the front, right hand end of the table. Also on lubrication or serial number plate located on left hand side of column.

On Vertical Machines, serial numbers are stamped on the front of right hand knee bearing of the column, at the top. The other two places are the same as for Horizontal Machines. See nomenclature chart on page 6 of Service Manual.

B—Size and type of machine is shown on the lubrication or serial number plate.

C—In giving part number and name of part wanted, tell us where part number was obtained, namely,

Number stamped on part.

Prior invoice.

Parts catalog.

If from parts catalog, give part number, name of part, key number and the page number.

D—In regard to urgency. Tell us whether machine is down, or if parts ordered are for stock.

E—Do not say to ship quickest way. Tell us how to ship. Parts may be sent Air Mail, Parcel Post Special Delivery, Parcel Post Regular, Express, Motor Freight, or Rail Freight.

Specify clearly just what you want. If parts are to be fitted, do not use the word "complete" as this always leaves a doubt in our minds as to how much to supply.

In some cases, due to nature of the part, it will be necessary for us to supply additional related parts, especially if part wanted is obsolete.

■ ■ ■

Throughout the following parts lists reference is made to MEDIUM SPEED and HIGH SPEED machines.

Nos. 1 and 2 MEDIUM SPEED machines have spindle speeds up to 500 R.P.M. Nos. 3 and 4 MEDIUM SPEED machines have spindle speeds up to 450 R.P.M.

Nos. 1 and 2 HIGH SPEED machines have spindle speeds up to 1500 R.P.M. Nos. 3 and 4 HIGH SPEED machines have spindle speed up to 1300 R.P.M.

PULLEY BRACKET UNIT PARTS

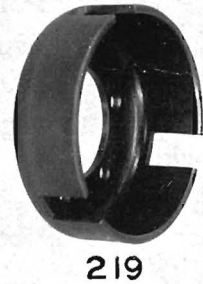
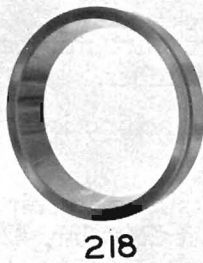
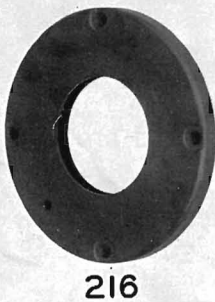
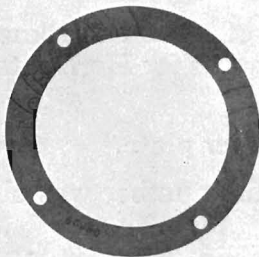
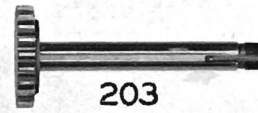
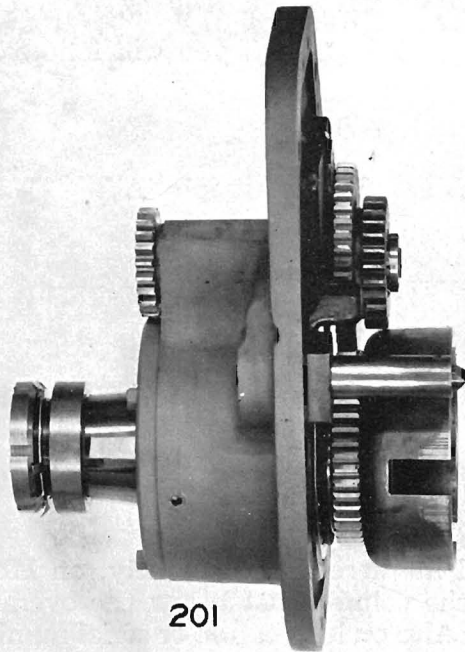

DPC-200

PULLEY BRACKET UNIT PARTS LIST

Key No.	Amt. Used	PART NAME	PART NUMBER to use when ordering	Key No.	Amt. Used	PART NAME	PART NUMBER to use when ordering
201	1	Bracket—Pulley (shown assembled)	71361	214	1	Spring . . . . .	3934
202	1	Plug—1 $\frac{3}{8}$ " diameter . . . . .	62581	215	1	Plunger—clutch yoke detent . . . . .	63118
203	1	Gear—pump drive . . . . .	65707	216	1	Plate—pulley bracket . . . . .	70324
204	1	Gear—pump driving . . . . .	75949	217	2	Cone—roller bearing Timken No. 598	57310
205	1	Washer—lock . . . . .	3807	218	2	Cup—roller bearing Timken No. 592B . . . . .	64052
206	1	Nut—lock . . . . .	3808	219	1	Flange—driving disc . . . . .	60996
207	1	Catcher—oil . . . . .	65074	220	1	Nut—lock 2 $\frac{3}{4}$ " . . . . .	3798
208	1	Collar—oil retainer . . . . .	65706	221	1	Washer—lock 2 $\frac{3}{4}$ " . . . . .	3797
209	2	Bearing—roller pump drive . . . . .	65605	222	1	Spacer—gear pump . . . . .	64351
210	1	Spacer—bearing pump drive . . . . .	65607	223	1	Nut—lock on sleeve gear . . . . .	70325
211	1	Gasket—plate pulley bracket . . . . .	66980	224	1	Sleeve—gear . . . . .	77852
212	1	Sleeve—clutch yoke detent lever . . . . .	68315	225	1	Bush—in sleeve gear . . . . .	68344
213	1	Pin . . . . .	62420				



# COOLANT PUMP AND PIPING PARTS

DPC-201

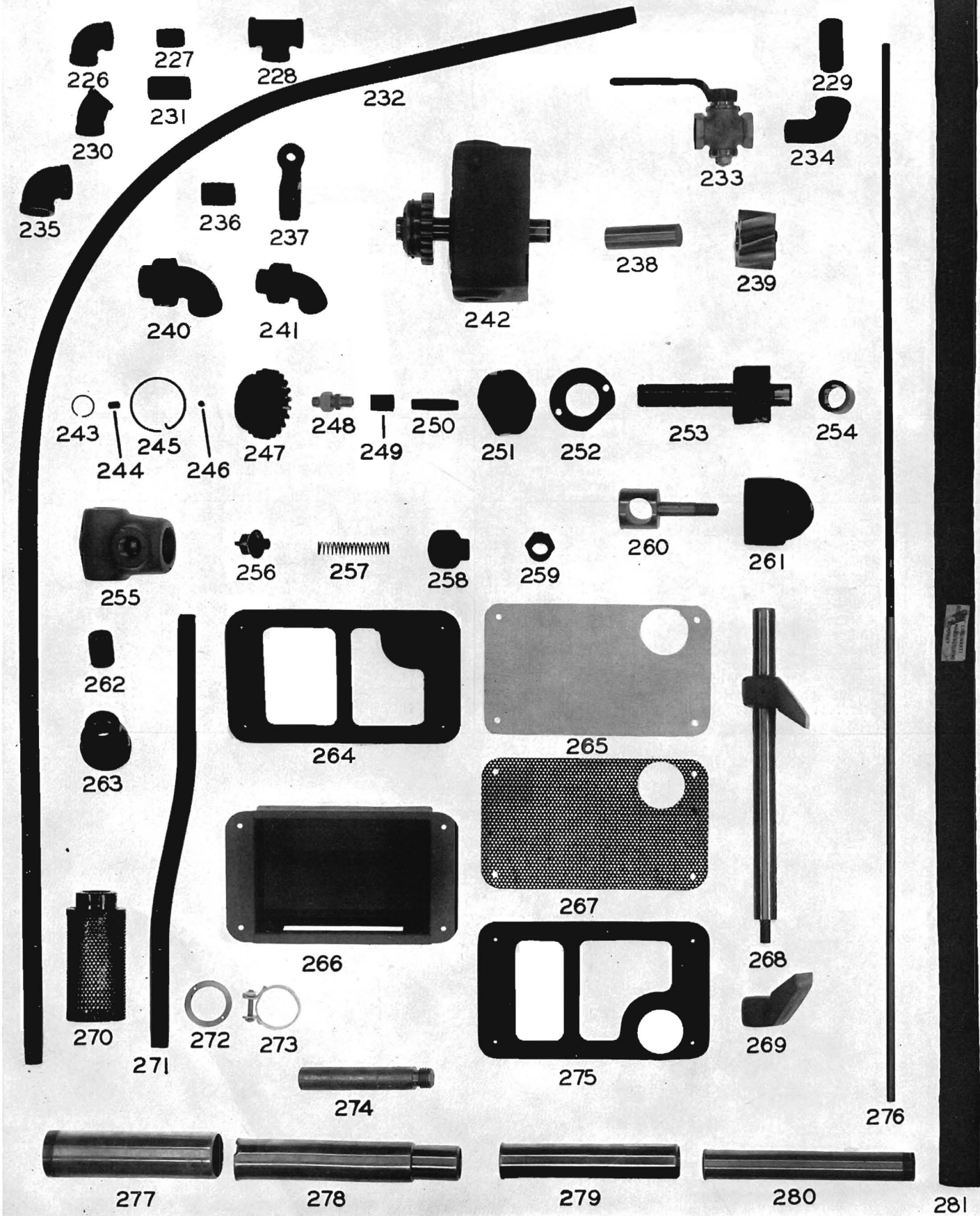



COOLANT PUMP AND PIPING PARTS LIST

Key No.	Amt. Used	PART NAME	PART NUMBER to use when ordering	Key No.	Amt. Used	PART NAME	PART NUMBER to use when ordering
226	3	Elbow—90°x1/2". 1-2-3-4 Plain and Univ.....	24800	255	1	Body—relief valve.....	67837
	2	1-2 Vertical		256	1	Valve—relief.....	30712
	2	3-4 Vertical		257	1	Spring—relief valve.....	30731
227	2	Nipple—1/2"x1 1/8". 4 Horz. 15 H. P. motor only.....	203424	258	1	Plug—body.....	30717
	1	Nipple—1/2"x1 1/2".....	24799	259	2	Bushing—1/2"x3/4".....	89138
228	1	Tee—1/2".....	91391	260	1	Holder—supply pipe.....	38592
229	1	Nipple—hose pipe 3/4"x2", one end threaded. Two used on Vertical Machines.....	82380	261	1	Clamp—supply pipe holder.....	38590
230	1	Elbow—45°x1/2". 4 Horz. 15 H. P. motor only.....	66086	262	1	Nipple—3/4"x1 3/8".....	24815
231	1	Nipple—3/4"x1 3/4". 1-2-3-4 Plain and Univ.....	29515	263	1	Coupling—reducing 3/4"x1 1/4".....	68427
232	1	Pipe—bent supply. 1-2 Vertical....	68961	264	1	Cover—strainer large in base.....	67669
	1	Pipe—bent supply. 3-4 Vertical....	69016	265	2	Strainer—large in base.....	62708
233	1	Valve—supply 3/4".....	42985	266	1	Body—strainer large.....	62710
234	1	Elbow—street 3/4".....	24792	267	2	Strainer—large.....	64107
235	1	Elbow—90°x3/4".....	12814	268	1	Shaft—overarm clamp. 1-2 Horz. only.....	63017F
236	2	Nipple—3/4"x1 3/8".....	24815		1	Shaft—overarm clamp. 3-4 Horz. only.....	63307F
237	1	Bracket—supply pipe.....	65210	269	1	Clamp—on overarm. 1-2-3-4 Horz. only.....	39574
238	1	Stud—Pump driven gear.....	62644	270	1	Strainer—in base.....	69577
239	1	Gear—Pump R. H. Helical.....	75218	271	1	Pipe—bent. 3-4 Horz. only.....	63301
240	1	Union—elbow 3/4".....	29475	272	1	Ring—threaded in strainer cover....	67424
241	1	Union—elbow 1/2".....	50935	273	2	Clamp—hose.....	57467
242	1	Body—Pump (shown assembled)....	71791	274	1	Stud—holder clamp. 1-2-3-4 Vertical only.....	55397
243	1	Spring—retainer drive shaft.....	45300	275	1	Cover—strainer large.....	62709
244	1	Pin—detent ball retainer.....	68522	276	1	Tubing—oil.....	71803
245	1	Ring—wire for detent pin.....	68523	277	1	Tube—1st Telescopic.....	66092
246	1	Ball—5/8" diameter.....	13665	278	1	Tube—2nd Telescopic (shown fitted with 66094).....	66093
247	1	Gear—pump driven.....	68525	279	1	Tube—3rd Telescopic.....	66094
248	1	Fitting—compression straight 3/8" tubing.....	57287	280	1	Tube—small Telescopic.....	66095
			20605	281	1	Hose—supply.....	74405
249	1	Coupling—pipe 1/4".....	202240	—	1	Pipe—List. 1 and 2 Plain and Univ. only.....	65218
250	1	Pipe—1/4"x2".....	71786	—	1	Pipe—List. 1 and 2 Vertical only....	66085
251	1	Bushing—outer bearing.....	71787	—	1	Pipe—List. 3 and 4 Vertical only....	65217
252	1	Gasket—outer bearing.....	71787	—	1	Pipe—List. 4 Horz. 15 H. P. motor only.....	75252
253	1	Shaft—pump drive.....	71788F	—	1	Pipe—List. 3 Plain and Univ. all motors.....	65209
	1	Gear—pump L. H. Helical. Fitted to above shaft.....	75219			4 Plain and Univ. 10 H. P. Motor only....	
254	1	Bush—pump shaft.....	69161				

Note: All pipe lists contain diameters and lengths of pipe only for particular size of machine.

# GEAR SHIFTER BRACKET PARTS

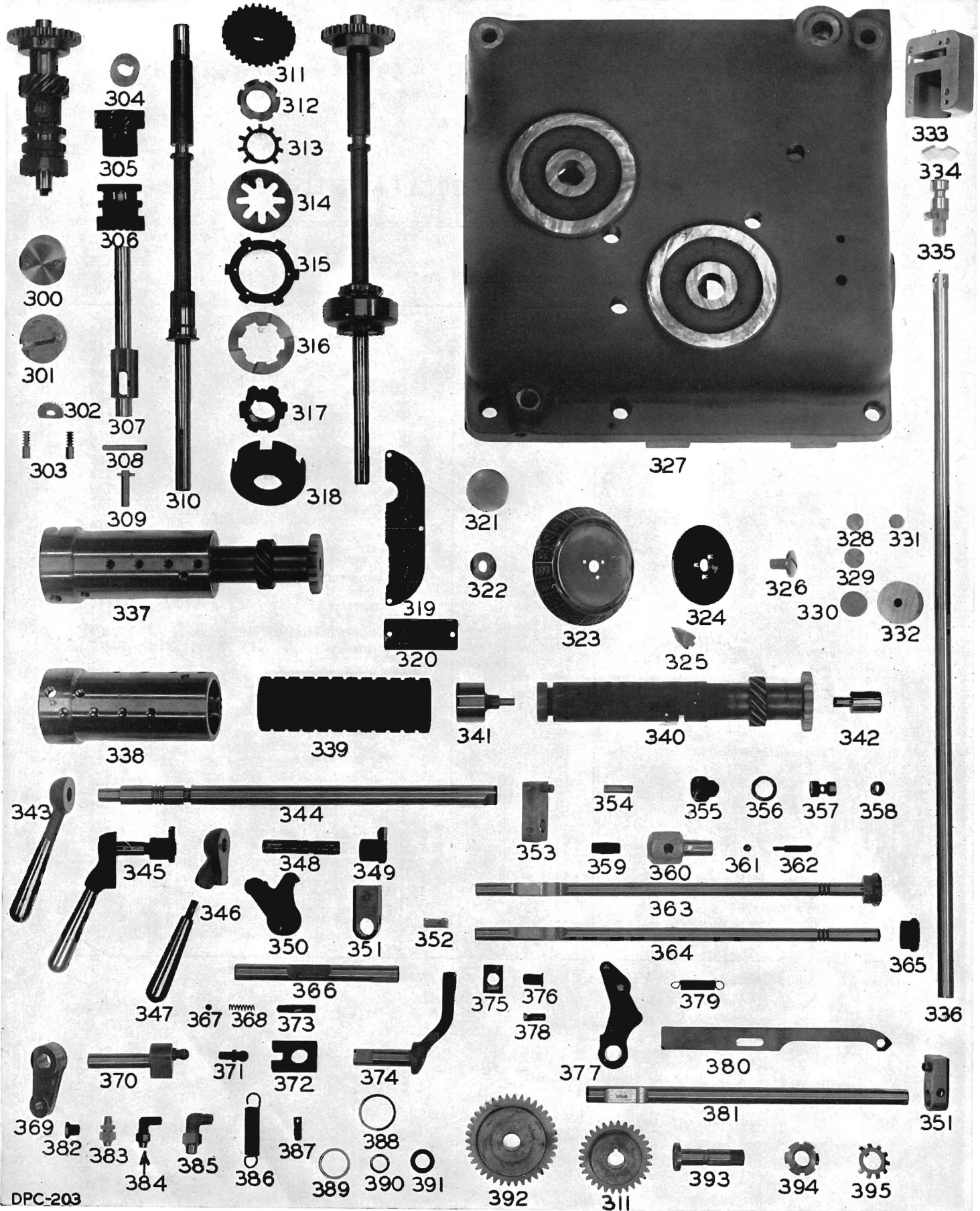

GEAR SHIFTER BRACKET PARTS LIST

Key No.	Amt. Used	PART NAME	PART NUMBER to use when ordering	Key No.	Amt. Used	PART NAME	PART NUMBER to use when ordering
300	1	Bearing—stop pin (fitted).....	62728F	342	1	Stud—selector valve R. H.....	66275
301	1	Bearing—stop pin.....	62728	343	1	Lever.....	3515
302	1	Pinion—for stop pin.....	66670	344	1	Shaft—Quick Traverse control in column.....	67119
303	2	Pin—stop.....	14155				
304	1	Collar—spacing.....	65203	345	1	Shaft—Rear speed and feed control (fitted).....	65171F
305	1	Gear—spiral speed cam.....	63321				
306	1	Clutch—speed dial engaging.....	66212	346	1	Lever—control.....	64185
307	1	Shaft—speed dial clutch.....	66213	347	1	Handle—control lever.....	64058
308	1	Pin—dial engagement clutch.....	65919	348	1	Shaft—rear speed and feed control..	65171
309	1	Pin—piston dial engagement interlock.....	66211	349	1	Dog.....	66673
			66211	350	1	Lever—detent.....	65088
310	1	Shaft—feed clutch shifter.....	69308	351	2	Lever.....	65195
311	4	Gear—dial operating.....	66792	352	2	Pin—straight in above lever.....	65550
312	1	Nut—lock. 1 1/8" diameter.....	3810	353	1	Lever—dial control shaft.....	67110
313	1	Washer—lock. 1 1/8" diameter.....	3809	354	1	Pin—dial control shaft lever.....	65189
314	1	Spring—friction clutch.....	67590	355	1	Screw—plug stuffing box.....	57024
315	4	Plate—driving clutch.....	64515	356	1	Gasket—copper asbestos. 3/4"x1 1/8"	57148
316	7	Plate—driven clutch friction.....	64516	357	1	Screw—stuffing box.....	65186
317	1	Spacer—clutch plates.....	64292	358	1	Packing—stuffing box.....	66375
318	1	Clutch—feed drive cam.....	64930	359	1	Nipple—pipe. 1/4"x1 1/4"	63162
319	1	Plate—indicator (English).....	65124	360	1	Body—relief valve.....	71973
320	1	Plate—dial instruction (English)...	71167	361	2	Ball—3/8" diameter.....	30154
321	1	Plug—expansion. 1 1/8" diameter...	69490	362	1	Plunger—relief valve.....	67813
322	2	Ring—on dial.....	75448	363	1	Shaft—dial control (fitted).....	69310F
323	1	Dial—speed. 1-2 High Speed Machines only.....	70246	364	1	Shaft—dial control.....	69310
				365	1	Gear—mitre dial control shaft.....	67111
	1	Dial—speed. 3-4 High Speed Machines only.....	69786	366	1	Shaft—speed drive control.....	65197
				367	1	Ball—5/16" diameter.....	13665
	1	Dial—speed. 1-2 Medium Speed Machines only.....	64970	368	1	Spring—detent.....	63525
				369	1	Lever—reverse.....	66554
	1	Dial—speed. 3-4 Medium Speed Machines only.....	65047	370	1	Shaft—reverse lever operating.....	69302
324	2	Plate—centre (American built).....	71830	371	1	Pin—ball shifting reverse gear.....	65178
	2	Plate—centre (English built).....	71831	372	1	Block—shifter reverse gear.....	65198
325	2	Pointer.....	65486	373	6	Pin—lock 3/8" x 1 1/8" long.....	33941
326	2	Screw—dial.....	65021	374	1	Lever—reverse gear shifter.....	69820
327	1	Bracket—gear shifter.....	74942	375	3	Shoe—(5 used on High Speed machines).....	69300
328	3	Plug—in gear shifter bracket. 3/4" diameter.....	63529	376	3	Pin—for above shoe (5 used on High Speed Machines).....	69301
329	1	Plug—in feed and speed bracket. 7/8" diameter.....	69316	377	2	Lever—feed and speed actuating... ..	68330
330	1	Plug—1 1/8" diameter.....	3830	378	3	Pin—spring in above lever.....	60154
331	1	Plug—5/8" diameter.....	3530	379	1	Spring.....	3967
332	1	Plug—1 1/8" diameter Medium Speed machines only.....	3562	380	1	Link—feed and speed control.....	66672
			69317	381	1	Shaft—feed drive control.....	65187
333	1	Bracket—feed and speed upper.....	69317	382	2	Bush—reducing 1/4" to 1/8" (Medium Speed only).....	58197
334	1	Key—in feed and speed bracket....	69319	383	5	Union—straight compression 1/4" tubing (8 used on High Speed machines).....	89866
335	1	Segment.....	69318				
336	1	Shaft—vertical control.....	69320				
337	1	Sleeve—outer selector valve. High Speed only (fitted).....	69779F	384	11	Elbow—compression 1/4" tubing (12 used on High Speed Machines)...	58152
	1	Sleeve—outer selector valve. Medium Speed only (fitted).....	67763F	385	2	Elbow—compression 3/8" tubing....	57286
338	1	Sleeve—outer selector valve. High Speed only.....	69779	386	1	Spring—extension.....	3944
	1	Sleeve—outer selector valve. Medium Speed only.....	67763	387	1	Pin—threaded spring 3/8" diameter..	67948
339	1	Bushing—selector valve. High speed only.....	70248	388	2	Gasket—copper asbestos 1 3/8"x1 5/8" (4 used on High Speed machines)	61181
				389	2	Gasket—copper asbestos 1 1/8"x1 3/8"	65233
				390	3	Gasket—copper asbestos 5/8"x1 7/8"	57906
				391	2	Gasket—copper 5/8"x1 1/16"	68454
	1	Bushing—selector valve. Medium Speed only.....	65087	392	1	Gear—idler dial operating large....	66793
340	1	Valve—selector. High Speed only..	73338	393	2	Stud—dial driving.....	75447
	1	Valve—selector. Medium Speed only	65140	394	2	Nut—lock 3/4" diameter.....	3806
341	1	Stud—selector valve L. H.....	65200	395	2	Washer—lock 3/4" diameter.....	3805

Continued on pages 36 and 37

GEAR SHIFTER BRACKET PARTS — Continued

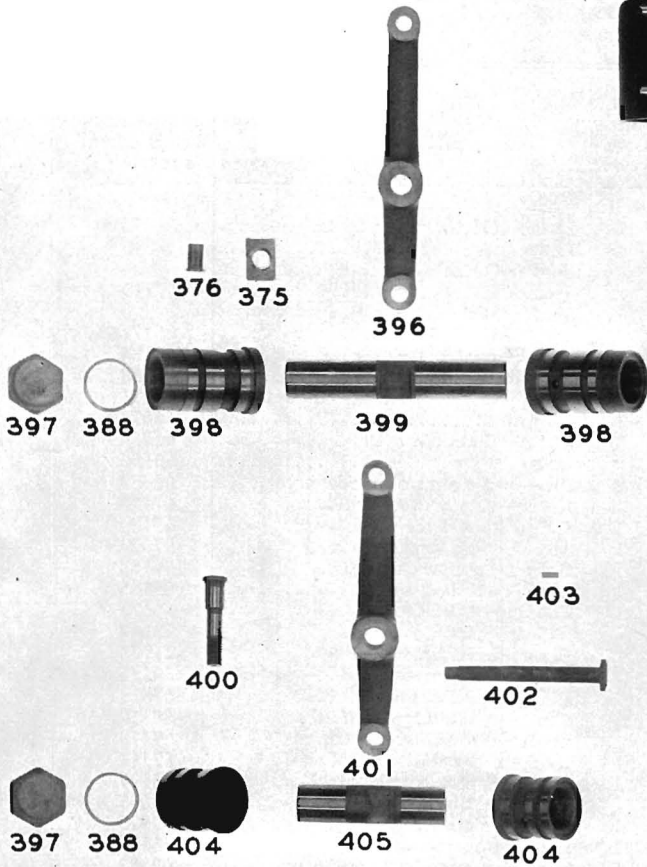
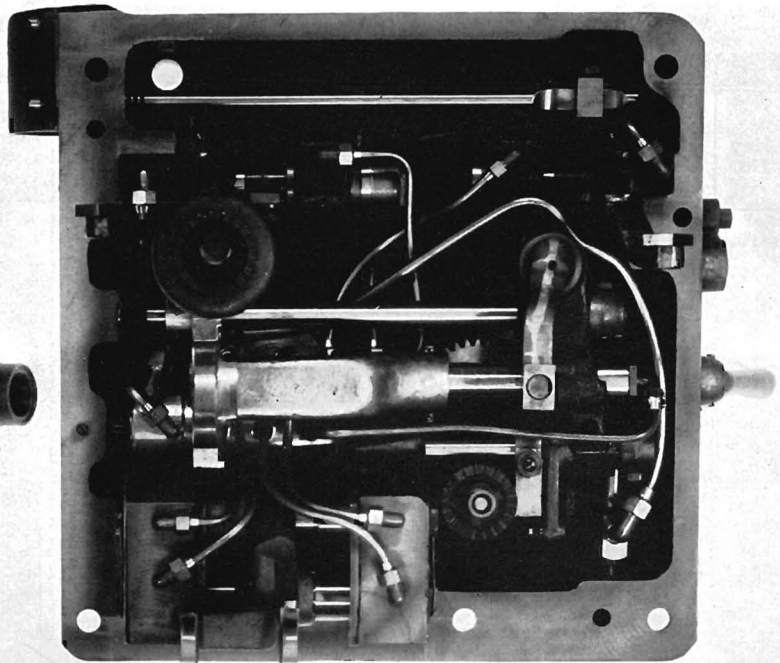

327



410

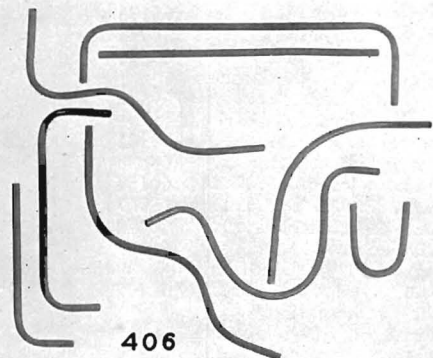

406

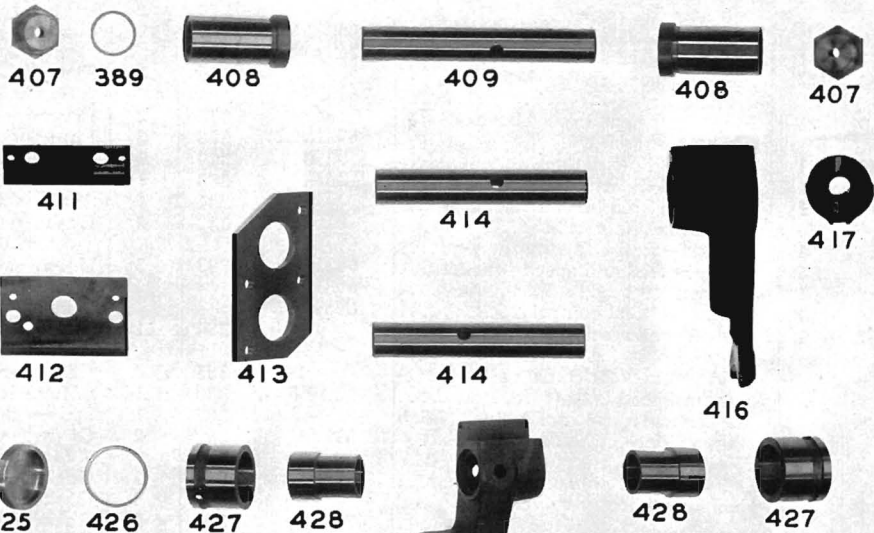

407

389

408

409

408

407

411

412

413

414

414

417

416

418

419

420

352

421

422

423

424

425

426

427

428

428

427

415

DPC-204

GEAR SHIFTER BRACKET PARTS LIST—Concluded

Key No.	Amt. Used	PART NAME	PART NUMBER to use when ordering	Key No.	Amt. Used	PART NAME	PART NUMBER to use when ordering
396	1	Lever—back gear shifting . . . . .	69306	408	2	Cylinder—secondary gear shifter . . .	69760
397	2	Screw—cylinder back gear shifter (4 used on High Speed Machines)	69774	409	1	Piston—secondary gear shifting . . .	69171
398	2	Cylinder—back gear shifter . . . . .	69762	410	1	Shifter—secondary gear . . . . .	67207
399	1	Piston—back gear shifter . . . . .	69298	411	1	Guide—upper primary gear lever . . .	74934
400	1	Bolt—2 used on High Speed Ma- chines . . . . .	69299	412	1	Guide—lower primary gear lever . . .	74935
401	1	Lever—clutch shifter (High Speed only) . . . . .	69307	413	2	Plate—abutment . . . . .	68417
402	1	Screw—piston adjusting (High Speed only) . . . . .	70245	414	2	Piston—primary gear shifter . . . . .	65937
403	1	Pin—(High Speed only) . . . . .	3636	415	1	Lever—rear primary gear shifter . . .	74937
404	2	Cylinder—clutch shifter (High Speed only) . . . . .	69773	416	1	Lever—front primary gear shifter . . .	74936
405	1	Piston—clutch shifter (High Speed only) . . . . .	70244	417	1	Disc—interlock . . . . .	65934
406	1	Tubing—complete list (High Speed only) . . . . .	74014	418	1	Bush—dial control shaft . . . . .	69783
	1	Tubing—complete list (Medium Speed only) . . . . .	73510	419	1	Pin—disc interlocking . . . . .	67026
407	2	Plug—cylinder secondary gear shifter	69759	420	3	Pin—shifter fork . . . . .	65172
				421	2	Bush—dial shaft . . . . .	63400
				422	1	Gear—idler dial operating small . . .	66791
				423	2	Stud—idler dial operating . . . . .	65158
				424	1	Pin . . . . .	65246
				425	4	Screw—cylinder end . . . . .	65935
				426	4	Gasket—copper asbestos 1 $\frac{5}{8}$ "x1 $\frac{7}{8}$ " . .	65125
				427	4	Cylinder . . . . .	65939
				428	4	Sleeve—gear shifting piston . . . . .	68418



# FEED BOX PARTS

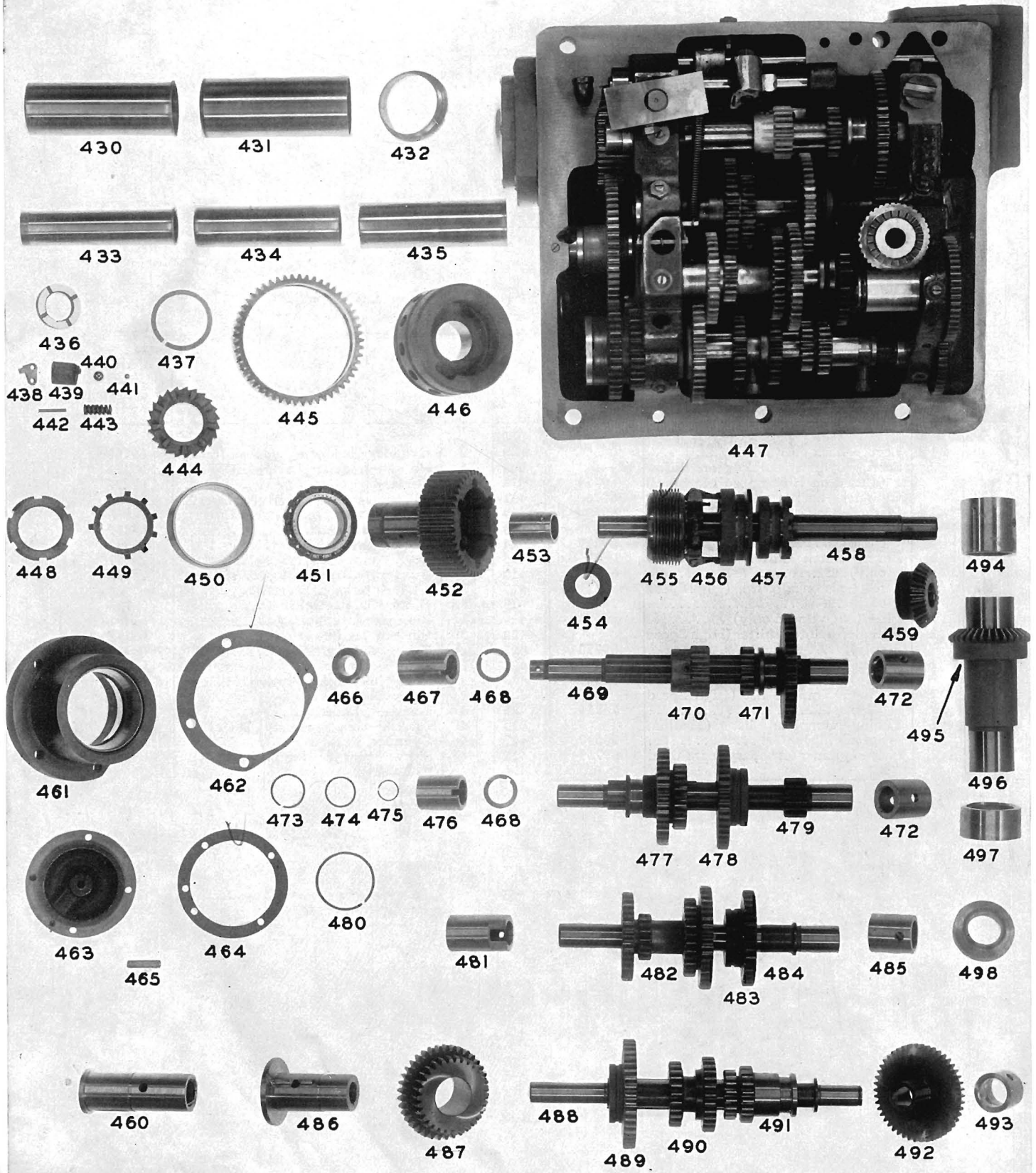

DPC-205



FEED BOX PARTS LIST

Key No.	Amt. Used	PART NAME	PART NUMBER to use when ordering	Key No.	Amt. Used	PART NAME	PART NUMBER to use when ordering
430	1	Tube—telescopic 4th.....	62852	464	1	Gasket—cover bearing retainer.....	62846
431	1	Tube—telescopic large.....	62850	465	1	Tube—oil.....	66957
432	1	Nut—telescopic tube.....	62849	466	1	Collar—shaft.....	3781
433	1	Tube—telescopic small. 1-2-3-4 Plain and Universal.....	62851	467	1	Bushing—small 4th feed shaft.....	66578
	1	Tube—telescopic small. 1-2-3-4 Vertical.....	63340	468	2	Collar—3rd and 4th feed shaft.....	62828
434	1	Tube—telescopic 2nd.....	62854	469	1	Shaft—4th feed.....	71327
435	1	Tube—telescopic 3rd.....	62853	470	1	Gear—pinned 4th feed shaft.....	64971
436	1	Washer—thrust 5th—feed shaft.....	65725	471	1	Gear—sliding 4th feed shaft.....	62833
437	1	Spring—drag ratchet.....	65724	472	2	Bushing—feed shaft.....	62817
438	1	Lifter—pawl ratchet.....	65722	473	1	Ring—spring. 1 <sup>1</sup> / <sub>16</sub> " O.D.....	71797
439	1	Pawl—safety gear (shown fitted with lifter and pins).....	65726	474	1	Ring—spring. 1 <sup>5</sup> / <sub>16</sub> " O.D.....	30059
440	12	Ball— <sup>1</sup> / <sub>2</sub> " diameter.....	36147	475	1	Ring—spring. <sup>7</sup> / <sub>8</sub> " O.D.....	71090
441	108	Ball— <sup>1</sup> / <sub>4</sub> " diameter.....	30060	476	1	Bushing—small 3rd feed shaft.....	62829
442	2	Pin—in pawl.....	93367	477	1	Gear—sliding 3rd feed shaft.....	62826
443	12	Spring—safety gear.....	65431	478	1	Gear—pinned 3rd feed shaft.....	62827
444	1	Ratchet—safety gear.....	65727	479	1	Shaft—3rd feed.....	62825
445	1	Gear—safety—this part and component parts should be fitted at factory.....	68007	480	3	Spring—wire ring. 2 <sup>1</sup> / <sub>2</sub> " O.D.....	62830
446	1	Hub—safety gear.....	67856	481	1	Bushing—2nd feed shaft.....	62822
447	1	Feed—Box (shown fitted complete).....	73067RF	482	1	Gear—cluster 2nd feed shaft.....	68938
	1	Feed—Box (not fitted).....	73067	483	1	Gear—2nd feed shaft.....	62820
448	1	Nut—lock. 1 <sup>7</sup> / <sub>8</sub> " diameter.....	3796	484	1	Shaft—2nd feed.....	71328
449	1	Washer—lock. 1 <sup>7</sup> / <sub>8</sub> " diameter.....	3795	485	1	Bushing—2nd feed shaft.....	71329
450	2	Cup—roller bearing Timken No. 363.....	58039	486	1	Bushing—1st feed shaft.....	73860
451	2	Cone—roller bearing Timken No. 366.....	58040	487	1	Gear—compound. High Speed Machines only.....	73866
452	1	Sleeve—clutch 5th feed shaft.....	66959		1	Gear—compound. Medium Speed Machines only.....	73892
453	1	Bushing—5th feed shaft.....	67454	488	1	Shaft—1st feed.....	73066
454	1	Washer—clutch.....	60681	489	1	Gear—1st feed shaft. High Speed Machines only.....	70070
455	1	Clutch—multiple disc.....	69581		1	Gear—1st feed shaft. Medium Speed Machines only.....	62814
456	1	Spool—sliding quick traverse.....	65734	490	1	Gear—sliding large 1st feed shaft.....	62815
457	1	Clutch—sliding, feed.....	65733	491	1	Gear—sliding small 1st feed shaft.....	62812
458	1	Shaft—5th feed.....	66960	492	1	Gear—driver cam drive.....	71334
459	1	Gear—bevel 5th feed shaft.....	70067	493	1	Bushing—1st feed shaft.....	71335
460	1	Sleeve—safety gear.....	65731	494	1	Bushing—upper vertical sleeve.....	69370
461	1	Retainer—roller bearing.....	66958	495	1	Gear—bevel vertical drive.....	70068
462	1	Shim—roller bearing retainer.....	63160	496	1	Sleeve—vertical.....	62848
463	1	Cover—clutch end.....	62845	497	1	Bushing—lower vertical sleeve.....	62859
				498	1	Retainer—lower vertical sleeve.....	62856

Continued on pages 40 and 41

FEED BOX PARTS — Continued

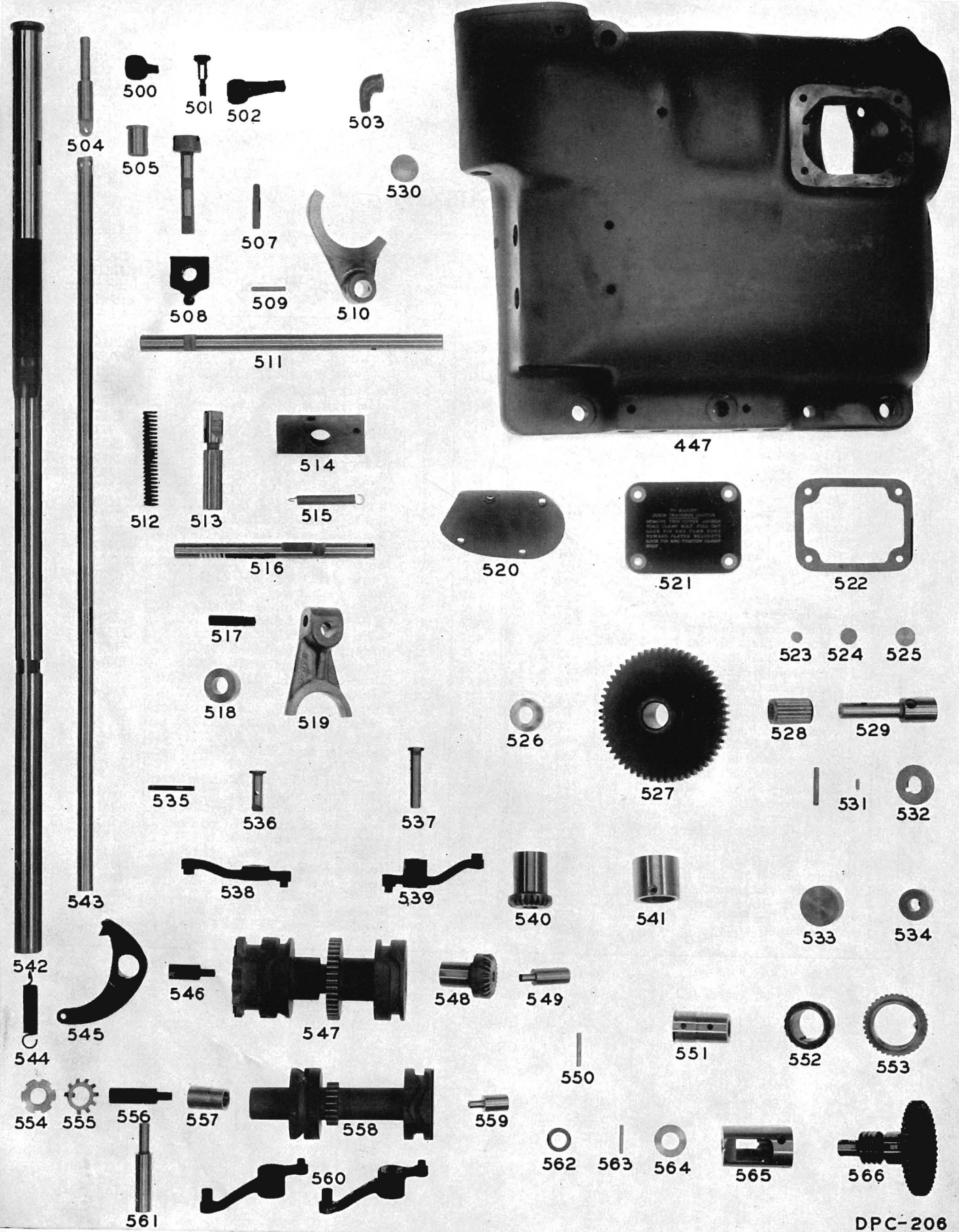

DPC-206

## FEED BOX PARTS LIST—Concluded

Key No.	Amt. Used	PART NAME	PART NUMBER to use when ordering	Key No.	Amt. Used	PART NAME	PART NUMBER to use when ordering
500	1	Lever—short quick traverse shifter.	69321	538	1	Lever—gear shifter, 3rd feed shaft . . .	62874
501	1	Stud—quick traverse long shifter shaft . . . . .	69372	539	1	Lever—gear shifter, 4th feed shaft . . .	62873
502	1	Lever—long, quick traverse shifter . .	69373	540	1	Gear—mitre cam drive . . . . .	62861
503	1	Elbow—street $\frac{1}{4}$ " pipe . . . . .	12838	541	1	Bushing—bevel gear cam drive . . . . .	62862
504	1	Shaft—quick traverse lever . . . . .	69322	542	1	Shaft—vertical spline. 1-2-3-4 Plain and Universal only . . . . .	68179
505	1	Bushing—quick traverse lever shaft . .	69371		1	Shaft—vertical spline. 1-2 Vertical (hand feed to head only) . . . . .	68180
506	1	Shaft—coupling quick traverse . . . . .	62869		1	Shaft—vertical spline. 3-4 Vertical (hand feed to head only) . . . . .	68181
507	2	Pin—lock $\frac{3}{8}$ "x2" . . . . .	33951		1	Shaft—vertical spline. 1-2 Vertical (power feed to head only) . . . . .	68182
508	1	Lever—quick traverse operating . . . . .	62870		1	Shaft—vertical spline. 3-4 Vertical (power feed to head only) . . . . .	68183
509	1	Pin—straight driving . . . . .	63772	543	1	Shaft—vertical control . . . . .	69320
510	1	Fork—shifter quick traverse . . . . .	65728	544	1	Spring . . . . .	3959
511	1	Rod—shifter quick traverse . . . . .	69382	545	1	Lever—detent . . . . .	65582
512	1	Spring—compression . . . . .	66510	546	1	Stud—cam shaft threaded . . . . .	62960
513	1	Pinion—shifter feed clutch . . . . .	65735	547	1	Cam—gear shifter large . . . . .	65788
514	1	Lever—clutch feed control . . . . .	65736	548	1	Gear—bevel cam shaft . . . . .	62957
515	1	Spring . . . . .	3918	549	1	Stud—cam shaft—long . . . . .	62959
516	1	Shaft—shifter feed clutch . . . . .	67021	550	1	Pin—gear bevel cam shaft. $\frac{1}{4}$ "x1 $\frac{1}{2}$ " . . . . .	62956
517	1	Pin—lock $\frac{1}{2}$ "x2" . . . . .	48073	551	1	Bush—spiral cam drive gear . . . . .	64322
518	1	Collar . . . . .	3982	552	1	Clutch—worm wheel—cam drive . . . . .	74801
519	1	Fork—shifter feed clutch . . . . .	67029	553	1	Gear—worm cam drive . . . . .	74800
520	1	Cover—on feed box . . . . .	69323	554	2	Nut—lock $\frac{3}{4}$ " diameter . . . . .	3806
521	1	Plate—cover instruction. (English) . . .	69510	555	2	Washer—lock $\frac{3}{4}$ " diameter . . . . .	3805
522	1	Gasket—feed box front cover . . . . .	63213	556	1	Stud—cam shaft—threaded long . . . . .	64690
523	2	Plug— $\frac{1}{2}$ " diameter . . . . .	3529	557	1	Bushing—detent lever . . . . .	64691
524	4	Plug— $\frac{3}{4}$ " diameter . . . . .	3549	558	1	Cam—gear shifter small . . . . .	64703
525	2	Plug— $\frac{7}{8}$ " diameter . . . . .	25258	559	1	Stud—cam shaft—short . . . . .	62953
526	1	Spacer—idler quick traverse . . . . .	70907	560	2	Lever—gear shifter, 1st feed shaft . . .	62875
527	1	Gear—quick traverse . . . . .	73865	561	2	Pin—lever, 1st feed shaft . . . . .	70636
528	1	Bearing—roller. Hyatt No. 93328 . . . .	70906	562	5	Gasket—copper $\frac{5}{8}$ "x1 $\frac{1}{16}$ " . . . . .	68454
529	1	Stud—idler quick traverse . . . . .	70905	563	1	Pin . . . . .	3542
530	1	Plug—expansion . . . . .	69448	564	1	Collar . . . . .	71332
531	4	Pin . . . . .	3636	565	1	Bushing—worm cam drive . . . . .	73259
532	1	Collar—thrust . . . . .	70908	566	1	Gear—driven cam drive . . . . .	73271
533	2	Plug—1 $\frac{3}{4}$ " diameter . . . . .	3554				
534	1	Plug—oil retainer 5th feed shaft . . . .	62842				
535	1	Pin—spring $\frac{1}{4}$ "x2" . . . . .	63630				
536	1	Pin—lever 3rd feed shaft . . . . .	62881				
537	1	Pin—lever 4th feed shaft . . . . .	62885				

# COLUMN PARTS

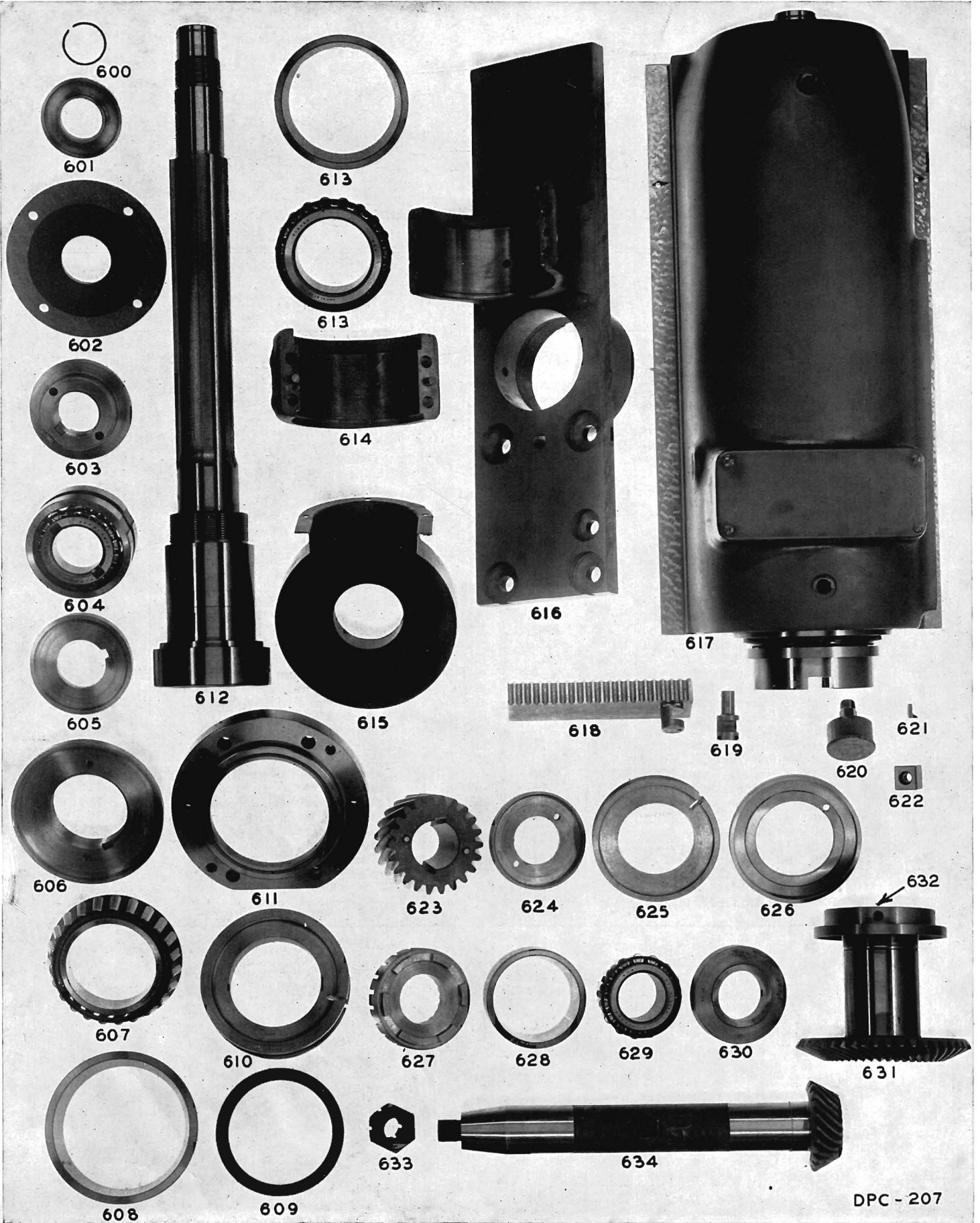

DPC - 207



COLUMN PARTS LIST

Key No.	Amt. Used	PART NAME	PART NUMBER to use when ordering	Key No.	Amt. Used	PART NAME	PART NUMBER to use when ordering
600	1	Spring—ring (1-2-3-4 Vertical) . . . .	57072	623	1	Gear—on spiral stem bevel (3-4 Vertical) . . . . .	73443
601	1	Cap—dust cover (1-2-3-4 Vertical) . .	64342	624	1	Retainer—grease, rear (1-2 Vertical)	73252
602	1	Cover—upper roller bearing (1-2-3-4 Vertical) . . . . .	63197	624	1	Retainer—grease, rear (3-4 Vertical)	73444
603	1	Nut—adjusting (1-2-3-4 Vertical) . . .	73268	625	1	Distributor—grease (1-2 Vertical) . .	73248
604	1	Bearing—roller (1-2-3-4 Vertical) . . .	70279	625	1	Distributor—grease (3-4 Vertical) . .	73450
605	1	Retainer—grease, $\frac{11}{16}$ " wide (1-2-3-4 Vertical) . . . . .	73245	626	1	Retainer—grease $\frac{15}{32}$ " wide (1-2 Vertical) . . . . .	73251
606	1	Nut—lock (1-2-3-4 Vertical) . . . . .	73270	626	1	Retainer—grease $\frac{1}{2}$ " wide (3-4 Vertical) . . . . .	73448
607	2	Cone—roller bearing (1-2-3-4 Vertical) . . . . .	56867	627	2	Nut—roller bearing adjusting (1-2 Vertical) . . . . .	73253
608	2	Cup—roller bearing (1-2-3-4 Vertical) . . . . .	62210	627	2	Nut—roller bearing adjusting (3-4 Vertical) . . . . .	73445
609	1	Guard—dust on spindle (1-2-3-4 Vertical) . . . . .	63199	628	2	Cup—roller bearing Timken No. 532A (1-2 Vertical) . . . . .	3581
610	1	Distributor—grease (1-2-3-4 Vertical) . . . . .	73247	628	2	Cup—roller bearing Timken No. 6220 (3-4 Vertical) . . . . .	63136
611	1	Cap—spindle (1-2-3-4 Vertical) . . . .	67734	629	2	Cone—roller bearing Timken No. 539 (1-2 Vertical) . . . . .	63190
612	1	Spindle—(1-2 Vertical) . . . . .	73273	629	2	Cone—roller bearing Timken No. 6280 (3-4 Vertical) . . . . .	63135
612	1	Spindle—(3-4 Vertical) . . . . .	73442	630	1	Retainer—grease, front (1-2 Vertical)	73244
613	2	Bearing—roller (1-2 Vertical) . . . . .	63562	630	1	Retainer—grease, front (3-4 Vertical)	73449
613	2	Bearing—roller (3-4 Vertical) . . . . .	67350	631	1	Gear—spiral bevel (1-2 Vertical). This gear is matched with gear No. 73258. . . . .	73257
614	1	Cap—bearing (1-2 Vertical) . . . . .	63539	631	1	Gear—spiral bevel (3-4 Vertical). This gear is matched with gear No. 73446. . . . .	73447
614	1	Cap—bearing (3-4 Vertical) . . . . .	63952	632	1	Nut—adjusting, bevel gear (1-2 Vertical) . . . . .	73267
615	1	Retainer—grease (1-2 Vertical) . . . .	74033	632	1	Nut—adjusting, bevel gear (3-4 Vertical) . . . . .	73451
615	1	Retainer—grease (3-4 Vertical) . . . .	75130	633	1	Nut—stem bevel gear (1-2-3-4 Vertical) . . . . .	70223
616	1	Bearing—for bevel gear (1-2 Vertical)	74092	634	1	Pinion—spiral stem bevel (1-2 Vertical). This gear is matched with gear No. 73257. . . . .	73258
616	1	Bearing—for bevel gear (3-4 Vertical)	74091	634	1	Pinion—spiral stem bevel (3-4 Vertical). This gear is matched with gear No. 73447. . . . .	73446
617	1	Head—vertical (1-2 machines) shown fitted . . . . .	73254				
617	1	Head—vertical (3-4 machines) shown fitted . . . . .	73441				
618	1	Rack—vertical feed (shown fitted with pin) . . . . .	65966				
619	1	Pin—rack (1-2 Vertical) . . . . .	66017				
619	1	Pin—rack $2\frac{15}{16}$ " long (3-4 Vertical) . .	65960				
620	5	Cup—grease (1-2-3-4 Vertical) . . . .	44395				
621	3	Key—roller bearing . . . . .	4004				
622	2	Key—spindle nose . . . . .	3687				
623	1	Gear—on spiral stem bevel (1-2 Vertical) . . . . .	73266				

Continued on pages 44 and 45

COLUMN PARTS — Continued

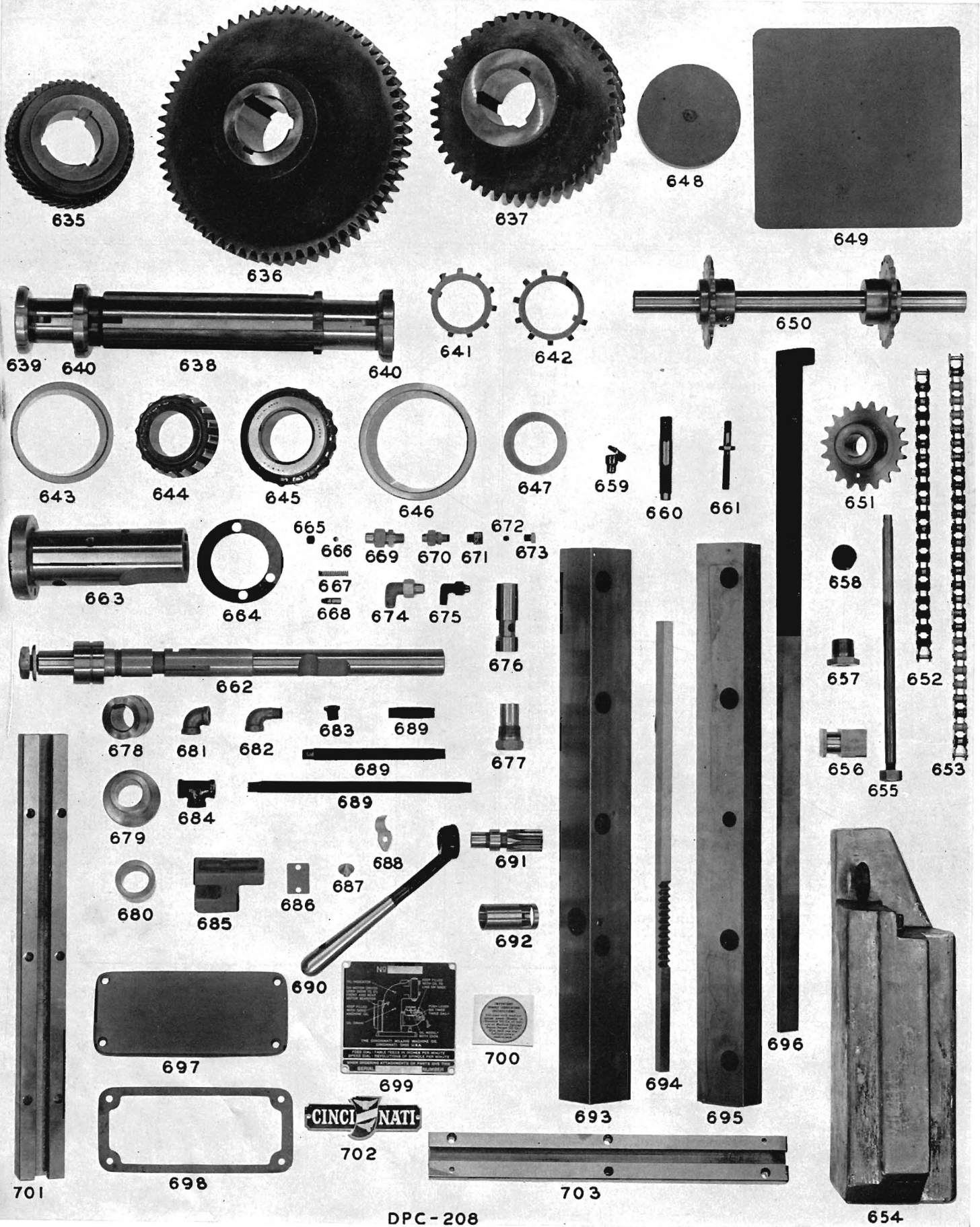

DPC - 208

COLUMN PARTS LIST—Continued

Key No.	Amt. Used	PART NAME	PART NUMBER to use when ordering	Key No.	Amt. Used	PART NAME	PART NUMBER to use when ordering
635	1	Gear—face, small (1-2 Vertical).....	70357	662	1	Shaft—starting (1-2-3-4 Horizontal Machines). This part should always be ordered fitted.....	70188
	1	Gear—face, small (3-4 Vertical).....	70359				
636	1	Gear—face, large (1-2 Vertical).....	70363	663	1	Sleeve—starting lever.....	70187
	1	Gear—face, large (3-4 Vertical).....	70366	664	1	Gasket—valve bushing.....	66366
637	1	Gear—face, front (1-2 Vertical).....	70360	665	4	Plug—pipe (1/8" dia.).....	62733
	1	Gear—face, front (3-4 Vertical).....	70361	666	1	Ball (1/4" dia.).....	30060
638	1	Shaft—5th drive (1-2-3-4 Vertical)...	70224	667	1	Spring—relief valve.....	65916
639	1	Nut—lock (1-2-3-4 Vertical).....	3813	668	1	Valve—relief.....	65913
640	2	Nut—lock (1-2-3-4 Vertical).....	3789	669	1	Union—compression 3/8" tubing.....	57287
641	1	Washer—lock 2" hole (1-2-3-4 Vertical).....	3643	670	1	Union—compression 1/2" tubing. 2 used on Vertical machines.....	89866
642	2	Washer—lock 2 1/4" hole (1-2-3-4 Vertical).....	3790	671	1	Adapter—1/8" pipe to 3/16" tubing (1-2-3-4 Vertical).....	60719
643	1	Cup—roller bearing Timken No. 453B (1-2 Vertical).....	63219	672	1	Sleeve—3/16" tubing (1-2-3-4 Vertical)...	60720
	1	Cup—roller bearing Timken No. 552B (3-4 Vertical).....	60194	673	1	Nut—3/16" tubing (1-2-3-4 Vertical)...	60721
644	1	Cone—roller bearing Timken No. 455 (1-2 Vertical).....	3579	674	1	Ell—compression, 3/8" tubing. (1-2-3-4 Vertical).....	57286
	1	Cone—roller bearing Timken No. 555 (3-4 Vertical).....	63742	675	3	Ell—compression, 1/4" tubing. (1-2 Vertical).....	58152
645	1	Cone—roller bearing Timken No. 555S (1-2 Vertical).....	63218	676	1	Distributor—grease (1-2-3-4 Vertical).....	73250
	1	Cone—roller bearing Timken No. 6375 (3-4 Vertical).....	3584	677	1	Stud—reducer (1-2 Vertical).....	73246
646	1	Cup—roller bearing Timken No. 552B (1-2 Vertical).....	60194	678	1	Clutch—starting lever.....	70186
	1	Cup—roller bearing Timken No. 6320B (3-4 Vertical).....	63133	679	1	Retainer—oil.....	66808
647	1	Spacer (1-2 Vertical).....	70222	680	1	Collar—on starting lever shaft.....	66807
648	1	Plug—4 1/2" dia. (1-2-3-4 Vertical)...	63217	681	2	Ell—1/4" pipe 90°. (1-2-3-4 Vertical)...	19284
	1	Plug—5 1/4" dia. (3-4 Vertical).....	63740	682	1	Ell—street, 1/4" pipe (1-2-3-4 Vertical).....	12838
649	1	Cover—over counter weight cavity (1-2 Vertical).....	64079	683	3	Bushing—reducing, 1/4" to 1/8" (1-2-3-4 Vertical).....	58197
	1	Cover—over counterweight cavity (3-4 Vertical).....	74072	684	2	Tee—1/4" pipe (1-2-3-4 Vertical).....	13660
650	1	Shaft—sprocket chain (shown fitted with two sprockets), (1-2 Vertical)...	66018	685	1	Body—sprayer, oil distributor (1-2-3-4 Vertical).....	64220
	1	Shaft—sprocket chain (shown fitted with two sprockets), (3-4 Vertical)...	65963	686	1	Baffle—spray body (1-2-3-4 Vertical)...	64219
651	2	Sprocket—counterweight (1-2 Vertical).....	63587	687	1	Sprayer (1-2-3-4 Vertical).....	30223
	2	Sprocket—counterweight (3-4 Vertical).....	74071	688	1	Clamp—oil tube.....	3990
652	1	Chain—Diamond Roller, L.H. (1-2 Vertical).....	63583	689	1	Pipe—list. Consists of 1 piece 1/4"x2" long, 2 pieces 1/4"x6 1/4" long and 1 piece 1/4"x9 3/4" long (1-2 Vertical)...	68783
	1	Chain—Diamond Roller, L.H. (3-4 Vertical).....	68137			Pipe—list. Consists of 1—1/4"x2", 1—1/4"x8 3/4", 1—1/4"x7 1/2" and 1—1/4"x10". (3-4 Vertical).....	66140
653	1	Chain—Diamond Roller, R.H. (1-2 Vertical).....	63585	690	1	Lever (1-2-3-4 Vertical).....	67838
	1	Chain—Diamond Roller, R.H. (3-4 Vertical).....	74006	691	1	Pinion—in head guide. (1-2-3-4 Vertical).....	69679
654	1	Counterweight, R.H. (1-2 Vertical)...	70997	692	1	Bush—in head guide. (1-2-3-4 Vertical).....	69681
	1	Counterweight, L.H. (1-2 Vertical)...	70996	693	1	Guide—for head, L.H. (1-2 Vertical)...	69826
	1	Counterweight, R.H. (3-4 Vertical)...	74070			Guide—for head, L.H. (3-4 Vertical)...	69828
	1	Counterweight, L.H. (3-4 Vertical)...	74069	694	1	Wedge—vertical head (1-2-3-4 Vertical).....	69684
655	2	Stud—in counterweight (1-2 Vertical).....	66020	695	1	Guide—for head, R.H. (1-2 Vertical)...	69825
	2	Stud—in counterweight (3-4 Vertical).....	63589			Guide—for head, R.H. (3-4 Vertical)...	69827
656	2	Bush—in counterweight (1-2-3-4 Vertical).....	68839	696	2	Gib—vertical head (1-2 Vertical)...	63541
657	2	Bushing—pipe (1-2-3-4 Vertical).....	58944			Gib—vertical head (1-2 Vertical)...	69824
658	2	Plug—3/4" pipe (1-2-3-4 Vertical)...	57726			Gib—vertical head (3-4 Vertical)...	63954
659	3	Cup—oil (1-2-3-4 Vertical).....	51737			Gib—vertical head (3-4 Vertical)...	69685
660	1	Stud—vertical head hand clamping (1-2-3-4 Vertical).....	63617	697	1	Cover—vertical head (1-2-3-4 Vertical).....	67488
661	3	Screw—gib.....	3989	698	1	Gasket—cover, vertical head (1-2-3-4 Vertical).....	67487
662	1	Shaft—starting lever (1-2-3-4 Vertical). This part should always be ordered fitted.....	70189	699	1	Plate—oiling. English (1-2-3-4 Vertical).....	66239
				700	4	Plate—transfer (1-2-3-4 Vertical).....	78789
				701	1	Guide—on column (1-2 Machines)...	65162
					1	Guide—on column (3-4 Machines)...	65161
				702	1	Plate—name, CINCINNATI.....	3966
				703	1	Guide—for dog on head (1-2-3-4 Vertical).....	63544

Continued on pages 46 and 47



COLUMN PARTS — Continued

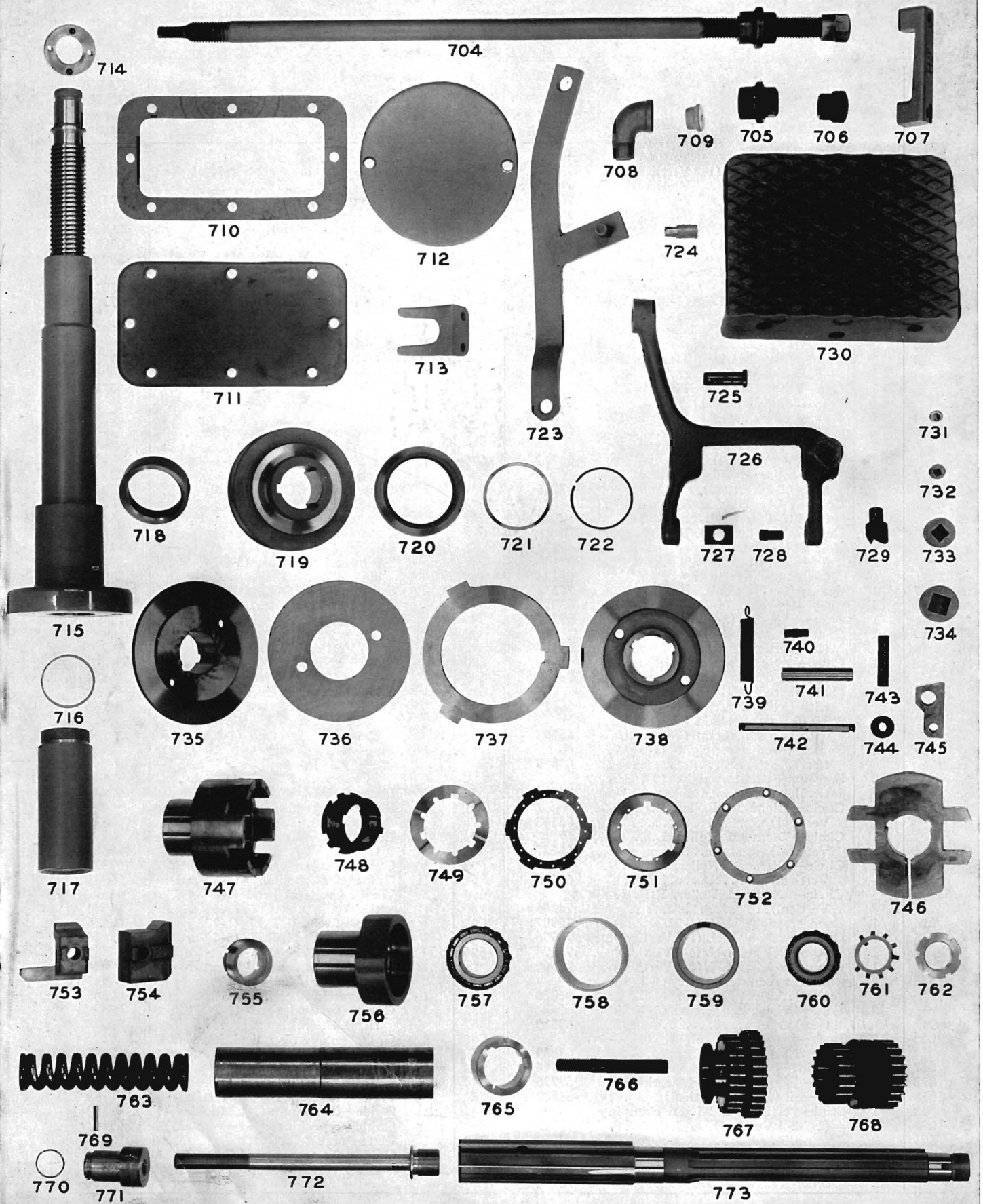

DPC-209

## COLUMN PARTS LIST—Continued

Key No.	Amt. Used	PART NAME	PART NUMBER to use when ordering	Key No.	Amt. Used	PART NAME	PART NUMBER to use when ordering
704	1	Bolt—arbor, draw in. (1-2 Vertical)	58547F	732	1	Plug—pipe. $\frac{3}{8}$ "	91551
	1	Bolt—arbor, draw in. (3-4 Vertical)	63596F	733	4	Plug—pipe. 1"	52823
	1	Bolt—arbor, draw in. (1-2 Horz.)	56329F	734	1	Plug—pipe. $1\frac{1}{4}$ "	60955
	1	Bolt—arbor, draw in. (3-4 Horz.)	64705F	735	1	Hub—driven disc	62183
705	1	Nut—draw in bolt	3641	736	1	Disc—driving center	57403
706	1	Head—draw in bolt	3639	737	2	Disc—driving	57402
707	1	Lock—for latch	3921	738	1	Ring—friction	67701
708	1	Elbow—street, $\frac{3}{4}$ " pipe	24792	739	2	Spring—clutch finger	57408
709	1	Plug—oil, filling hole	3987	740	2	Pin—clutch disc	63932
710	1	Cover—base reservoir	67670	741	2	Pin—clutch finger carrier	36877
711	1	Gasket—base cover reservoir	67671	742	2	Pin—clutch finger	57411
712	1	Cover—upper column	64059	743	1	Pin—lock in carrier	36861
713	1	Bracket—supply hose	68046	744	2	Roller—for detent lever	33273
714	1	Nut—on elevating screw	63165	745	2	Finger—clutch	37983
715	1	Screw—elevating. English. (1-2 Vertical and Univ.)	69671F	746	1	Carrier—clutch finger	57407
	1	Screw—elevating. Metric. (1-2 Vertical and Univ.)	70274F	747	1	Hub—disc brake. (1-2 Machines)	73063
	1	Screw—elevating. English. (1-2 Plain)	69670FA	748	1	Hub—disc brake. (3-4 Machines)	73383
	1	Screw—elevating. Metric. (1-2 Plain)	70273FA	749	5	Hub—clutch brake	74830
	1	Screw—elevating. English. (3-4 Plain)	70283F	750	5	Plate—driving	73058
	1	Screw—elevating. Metric. (3-4 Plain)	70284F	751	5	Plate—driven	73057
	1	Screw—elevating. English. (3-4 Univ. and Vertical)	69670FB	752	1	Plate—floating	73061
	1	Screw—elevating. Metric. (3-4 Univ. and Vertical)	70273FB	753	1	Plate—disc retainer	73055
716	1	Gasket	67965	754	1	Dog—lower on column	65160
717	1	Tube—oil retainer. (1-2 Plain, Univ. and Vertical)	68403	755	1	Dog—upper on column	65159
	1	Tube—oil retainer. (3-4 Plain, Univ. and Vertical)	68405	756	1	Nut—sleeve outer	59060
718	1	Collar—elevating nut. (1-2-3-4 Plain)	63161	757	1	Adapter—first drive shaft. (3-4 Machines)	62977
719	1	Clutch—spool	73062	758	1	Cone—roller bearing. Timken No. 336	59687
720	1	Ring—clutch spool	67657	759	1	Cup—roller bearing. Timken No. 333	59688
721	1	Washer—clutch spool	57410	760	1	Cup—roller bearing. Timken No. 2523B	62189
722	1	Spring—locking	57412	761	1	Cone—roller bearing. Timken No. 2582	62188
723	1	Link—clutch shifter. (1-2 Machines)	70234	762	1	Washer—lock. $1\frac{1}{4}$ " dia.	3791
	1	Link—clutch shifter. (3-4 Machines)	69335	763	1	Nut—lock. $1\frac{1}{4}$ " dia.	3792
724	1	Pin—starting lever link	66340	764	1	Spring—on pulley shaft	52502
725	2	Pin—starting lever	66429	765	1	Sleeve—clutch spring	60564
726	1	Fork—clutch shifter. (1-2 Machines)	74090	766	1	Spacer—clutch brake. (3-4 Machines only)	73382
	1	Fork—clutch shifter. (3-4 Machines)	66433	767	1	Screw—in column. (3-4 Machines only)	64179
727	2	Shoe—clutch shifter	64940	768	1	Gear—large, first drive shaft	65945
728	2	Pin—shifter shoe	46855	769	1	Gear—small, first drive shaft	65944
729	1	Detent	63119	770	1	Pin—straight	68433
730	1	Foot—step large. (3-4 Vertical)	69633	771	1	Spring—impeller shaft	30059
731	1	Plug—pipe. $\frac{1}{4}$ "	200311	772	1	Nut—spring adjusting	61285
				773	1	Rod—clutch spring	61286
					1	Shaft—first drive. (1-2 Machines)	62182
					1	Shaft—first drive. (3-4 Machines)	73381

Continued on pages 48 and 49

COLUMN PARTS — Continued

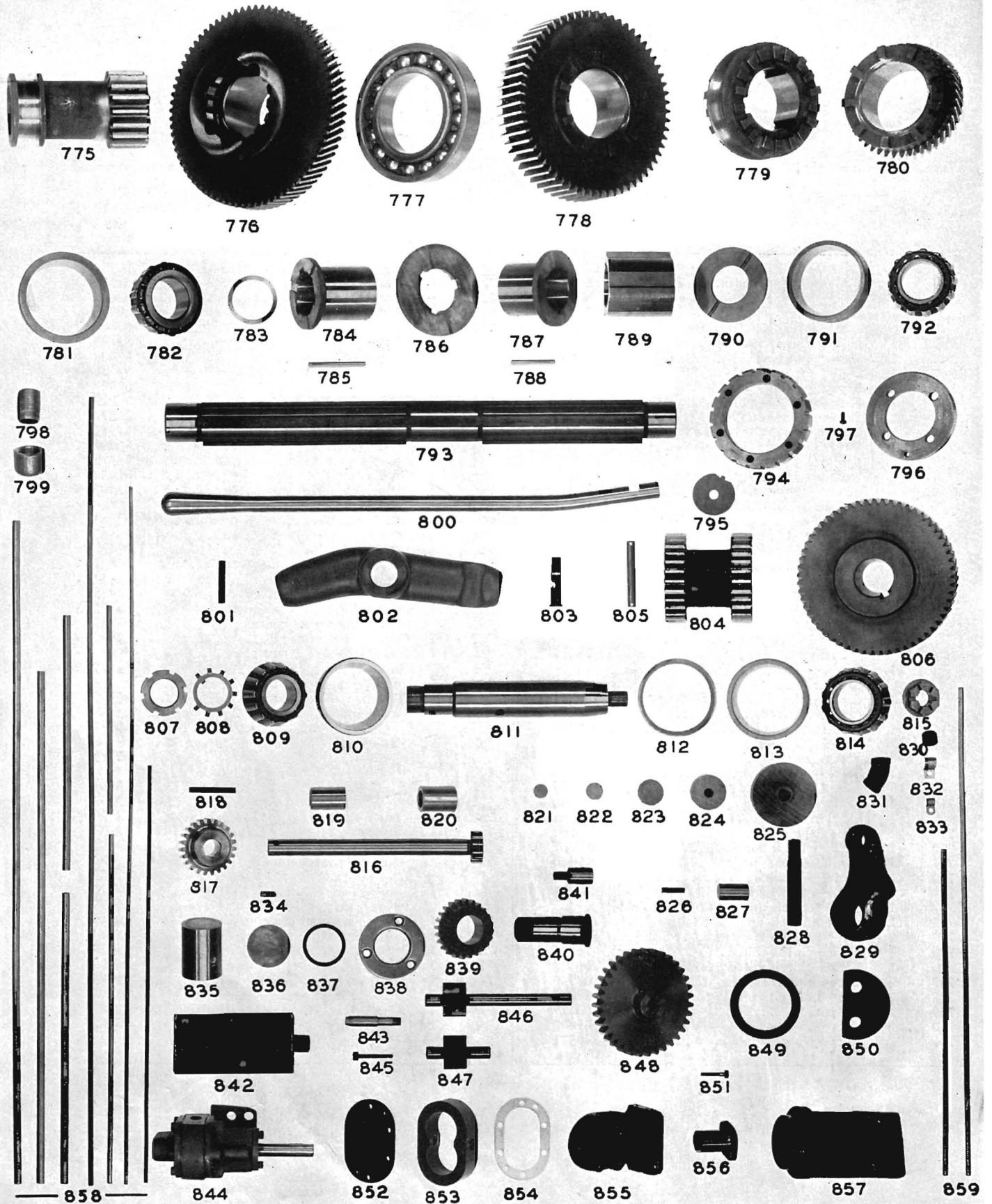

DPC-210

COLUMN PARTS LIST—Continued

Key No.	Amt. Used	PART NAME	PART NUMBER to use when ordering	Key No.	Amt. Used	PART NAME	PART NUMBER to use when ordering
775	1	Gear—sliding back. (1-2 Machines)	70212	799	1	Cap—pipe. 3/4"	200786
	1	Gear—sliding back. (3-4 Machines)	69343	800	1	Handle—starting lever	66051
776	1	Gear—back. (1-2 Machines)	70369	801	1	Pin—lock starting lever	35568
	1	Gear—back. (3-4 Machines)	70368	802	1	Lever—starting	70190
777	1	Bearing—ball. (1-2 Machines) N.D. No. 1217-X	70207	803	1	Pin—lock	34410
	1	Bearing—ball. (3-4 Machines) N.D. No. 1219-X	69348	804	1	Gear—reverse shaft	69362
778	1	Gear—clutch large. (1-2 High Speed Machines)	75005	805	1	Pin—straight driving	63193
	1	Gear—clutch large. (3-4 High Speed Machines)	75008	806	1	Gear—reverse shaft. (1-2 High Speed Machines)	70216
	1	Gear—large—back gear shaft. (1-2 Medium Speed Machines)	73517		1	Gear—reverse shaft. (3-4 High Speed Machines)	70249
	1	Gear—large—back gear shaft. (3-4 Medium Speed Machines)	73524	807	1	Nut—lock. 1 1/4" dia.	3792
779	1	Clutch—back gear shaft. (1-2 High Speed Machines)	75006	808	1	Washer—lock. 1 1/4" dia.	3791
	1	Clutch—back gear shaft. (3-4 High Speed Machines)	75009	809	2	Cone—roller bearing. Timken No. 3478	62200
780	1	Gear—clutch small. (1-2 High Speed Machines)	75007	810	1	Cone—roller bearing. Timken No. 3420B	62199
	1	Gear—clutch small. (3-4 High Speed Machines)	75010	811	1	Shaft—reverse	70253
781	1	Cup—roller bearing. Timken No. 432B (1-2 Machines)	204053	812	1	Spacer—roller bearing	73229
	1	Cup—roller bearing. Timken No. 453B (3-4 Machines)	63219	813	1	Cup—roller bearing. Timken No. 414	73227
782	1	Cone—roller bearing. Timken No. 438 (1-2 Machines)	3576	814	1	Cone—roller bearing. Timken No. 419	73228
	2	Cone—roller bearing. Timken No. 455 (3-4 Machines)	3579		1	Nut—reverse shaft	70252
783	1	Spacer—back gear shaft. (1-2 Machines only)	74944	815	1	Shaft—speed cam clutch drive	63320
784	1	Hub—roller bearing. (1-2 Machines)	70206	816	1	Gear—spiral	73260
	1	Hub—roller bearing. (3-4 Machines)	70367	817	1	Pin	63630
785	33	Roller—1/4"x2 1/2". (1-2 High Speed), (38 on 3-4 High Speed)	69349	818	1	Bushing	65905
786	1	Spacer—back gear shaft. (1-2 Machines)	70205	819	1	Bushing	3832
	1	Spacer—back gear shaft. (3-4 Machines)	69351	820	1	Plug—1/2" diameter. (5 used on 1-2 Vertical)	3530
787	2	Hub—roller bearing. (1-2 High Speed Machines)	70200	821	3	Plug—3/4" diameter. (2 used on 1-2 Vertical), (3 used on 3-4 Plain and Universal)	3549
	1	Hub—roller bearing. (1-2 Medium Speed only)	70218	822	1	Plug—1 1/8" diameter. (3-4 Machines)	3830
	1	Hub—roller bearing. (3-4 High Speed Machines)	69355	823	1	Plug—1 1/2" diameter	3553
	1	Hub—roller bearing. (3-4 Medium Speed only)	70220	824	2	Plug—2 3/4" diameter	3558
	1	Hub—roller bearing. (3-4 High Speed only)	70367	825	3	Pin	3543
788	66	Roller—1/4"x1 1/8". (1-2 High Speed), (38 on 3-4 High Speed)	69354	826	3	Pin—stop in column	68999
789	1	Sleeve—clutch. (1-2 High Speed Machines)	70203	827	1	Pin—lock	34717
	1	Sleeve—clutch. (3-4 High Speed Machines)	69357	828	1	Shifter—starting lever	66806
790	1	Spacer—back gear shaft. (1-2 High Speed Machines)	70199	829	1	Bushing—reducing 3/8" to 1/4" pipe	66279
	1	Spacer—back gear shaft. (3-4 High Speed Machines)	69360	830	2	Elbow—45°	31080
791	1	Cup—roller bearing. Timken No. 414 (3-4 Machines)	73227	831	2	Clamp—oil tube, 3/8" tubing	4002
	1	Cup—roller bearing. Timken No. 452 (3-4 Machines)	59878	832	1	Clamp—oil tube, 1/4" tubing. (1-2-3-4 Plain and Univ.)	4001
792	1	Cone—roller bearing. Timken No. 419 (1-2 Machines)	73228	833	2	Tube—(1-2-3-4 Vertical)	3876
	2	Cone—roller bearing. Timken No. 455 (3-4 Machines)	3579	834	1	Body—oil sight gage	63015
793	1	Shaft—back gear. (1-2 Machines)	70213	835	1	Disc—oil gage	3849
	1	Shaft—back gear. (3-4 Machines)	69342	836	1	Gasket—oil gage	3850
794	1	Nut—adjusting. (3-4 Machines only)	3593	837	2	Cover—oil gage	3848
795	1	Washer—lock. (3-4 Machines only)	67267	838	1	Gear—speed dial drive	65917
796	1	Nut—adjusting. (1-2 Machines only)	70197	839	1	Cylinder—dial engaging interlock	66157
797	1	Screw—in adjusting nut. (1-2 Machines only)	70198	840	1	Piston—dial engaging interlock	66210
	1	Nipple—close. 3/4"	24815	841	1	Strainer—oil	65540
				842	1	Pin—dowel	65185
				843	1	Pump—#1. (assembled complete)	73145
				844	1	Screw—body	61356
				845	6	Gear—pinion driving	202297
				846	1	Gear—pinion driven	57781
				847	1	Gear—pump	75950
				848	1	Gasket—for pump support	75167
				849	1	Clamp—pump support	71365
				850	1	Screw—gland	57786
				851	2	Cover—pump	58163
				852	1	Spacer	73047
				853	1	Gasket	57775
				854	4	Body—pump	57772
				855	1	Gland	57776
				856	1	Support—pump	71794
				857	1	Tubing—oil in column. (1-2 Plain and Universal)	70259
				858	1 set	Tubing—oil in column. (1-2 Vertical)	66136
					1 set	Tubing—oil in column. (3-4 Plain and Universal)	70260
					1 set	Tubing—oil in column. (3-4 Vertical)	66141
				859	1 set	Tubing—oil. (1-2 Vertical)	68946
					1 set	Tubing—oil. (3-4 Vertical)	68949

Continued on pages 50 and 51



COLUMN PARTS — Continued

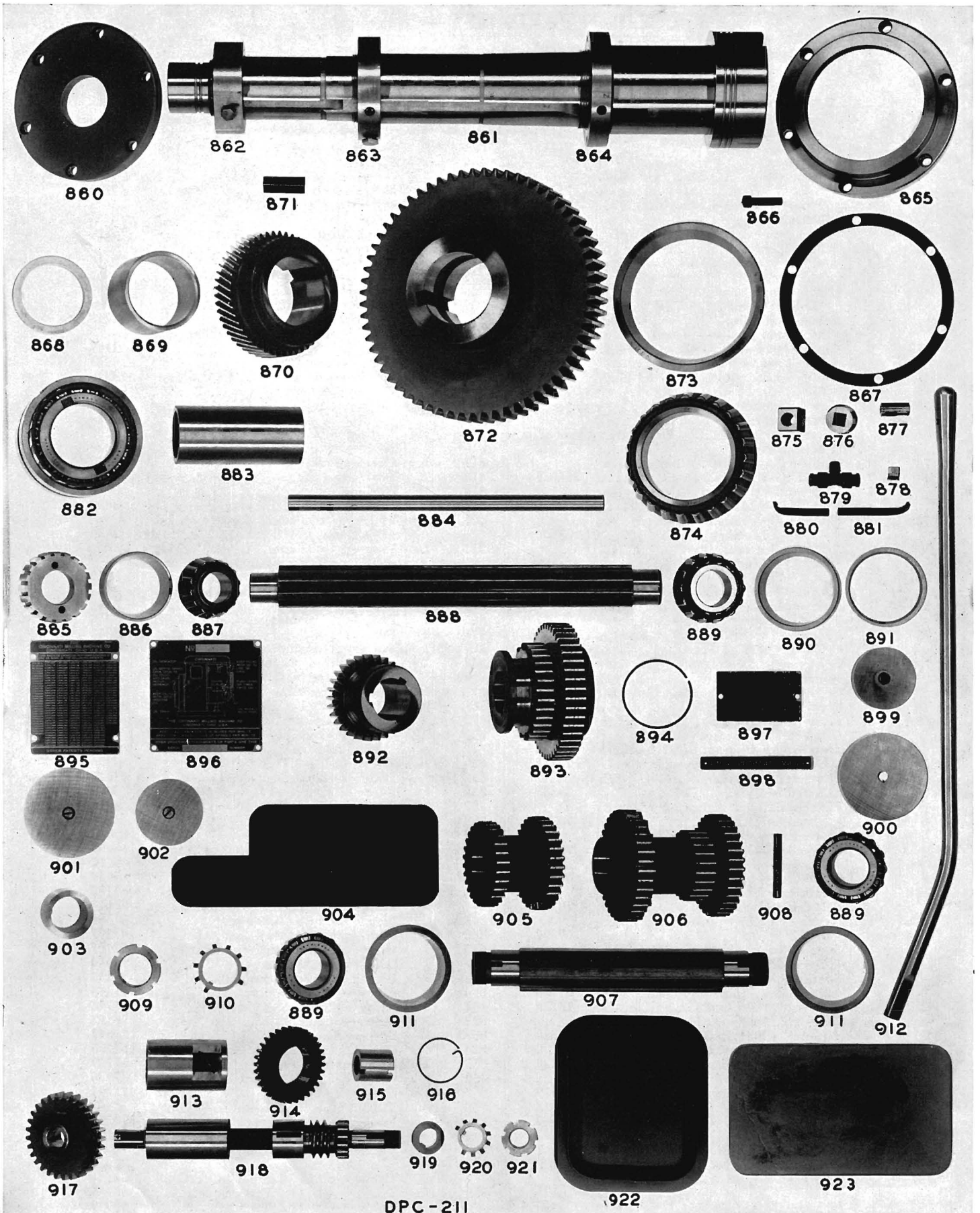

DPC-211

922

923

## COLUMN PARTS LIST—Continued

Key No.	Amt. Used	PART NAME	PART NUMBER to use when ordering	Key No.	Amt. Used	PART NAME	PART NUMBER to use when ordering
860	1	Cover—spindle, rear. (1-2-3-4 Plain and Univ.)	69341	890	2	Cup—roller bearing. Timken No. 432	3572
861	1	Spindle—(1-2 Plain and Universal)	70991	891	1	Spacer—roller bearing	3615
	1	Spindle—(3-4 Plain and Universal)	73844	892	1	Gear—small third drive shaft	69366
862	1	Nut—lock, rear spindle. (1-2-3-4 Plain and Univ.)	3857	893	1	Gear—sleeve (fitted with gear 65943)	66090
863	1	Nut—lock. (1-2-3-4 Plain and Univ.)	3999	894	1	Spring—ring	89510
864	1	Nut—lock. (1-2-3-4 Plain and Univ.)	3853	895	1	Plate—patent. Domestic	75046
865	1	Cap—spindle, front. (1-2-3-4 Plain and Universal)	62209		1	Plate—patent. Foreign	75045
866	6	Screw—spindle cap	75269	896	1	Plate—oil. English	66240
867	1	Gasket—spindle cap. (1-2-3-4 Plain and Universal)	66418	897	1	Plate—Caution. English	74087
868	1	Washer—bearing. (1-2-3-4 Plain and Universal)	70987	898	1	Plate—on small louvre. English	53199
869	1	Spacer—on spindle. (1-2-3-4 Plain and Universal)	70191	899	2	Plug— $2\frac{3}{4}$ " dia.	3558
870	1	Gear—face, small. (1-2 Plain and Universal)	70356	900	1	Plug— $3\frac{1}{8}$ " dia.	67265
	1	Gear—face, small. (3-4 Plain and Universal)	70358	901	1	Plug—4" dia. (1-2 Machines)	70196
871	1	Key—(1-2-3-4 Plain and Universal)	74546	902	1	Plug—in column. $2\frac{1}{8}$ " dia.	63817
872	1	Gear—face, large. (1-2 Plain and Universal)	70362	903	1	Spacer. (1-2-3-4 Medium Speed Machines)	70217
	1	Gear—face, large. (3-4 Plain and Universal)	70365	904	1	Cover—column top. (1-2 Plain and Universal)	69802
873	2	Cup—roller bearing. Timken No. 52637B (1-2-3-4 Plain and Univ.)	62600		1	Cover—column top. (3-4 Plain and Universal)	69804
874	2	Cone—roller bearing. Timken No. 52387W	56867	905	1	Gear—small second drive shaft	65946
875	2	Key—spindle nose	3687	906	1	Gear—large second drive shaft	65942
876	1	Plug—pipe. (1-2-3-4 Plain and Universal)	56265	907	1	Shaft—second drive	65949
877	2	Plug—oil in column. (1-2-3-4 Plain and Universal)	64180	908	2	Pin—straight driving	63193
878	3	Key	4004	909	2	Nut—lock	3804
879	1	Tee—compression. (1-2-3-4 Plain and Universal)	70258	910	2	Washer—lock	3803
880	1	Tube—reservoir filling. (1-2-3-4 Plain and Universal)	70257	911	2	Cup—roller bearing. Timken No. 432AB	68118
881	1	Tube—oil spray. (1-2-3-4 Plain and Universal)	70256	912	1	Handle—starting lever. (1-2 Machines)	67846
882	1	Bearing—double roller. (1-2-3-4 Plain and Universal)	69023		1	Handle—starting lever. (3-4 Horz. and Vertical)	65355
883	1	Spacer—(1-2 Machines. Medium Speed only)	70218		1	Handle—starting lever. (3-4 Vertical)	65399
	1	Spacer. (3-4 Machines. Medium Speed only)	70220	913	1	Bush—feed drive shaft. (1-2 Machines)	70227
884	1	Shaft—clutch lever shifter. (1-2 Machines)	62738		1	Bush—feed drive shaft. (3-4 Machines)	70229
	1	Shaft—clutch lever shifter. (3-4 Machines)	64951	914	1	Gear—feed drive shaft—small. (1-2-3-4 High Speed Machines)	73867
885	1	Nut—roller bearing adjusting	3592		1	Gear—feed drive shaft, small. (1-2-3-4 Medium Speed Machines)	73843
886	1	Cup—roller bearing. Timken No. 3420	3570	915	1	Bushing—small	64270
887	2	Cone—roller bearing. Timken No. 3478	62200	916	1	Ring—spring locking	62693
888	1	Shaft—third drive	69365	917	1	Gear—feed drive shaft	75951
889	3	Cone—roller bearing. Timken No. 447	62205	918	1	Shaft—single worm feed drive. (1-2 High Speed Machines)	73269
					1	Shaft—single worm feed drive. (1-2 Medium Speed Machines)	73421
					1	Shaft—single worm feed drive. (3-4 High Speed Machines)	73380
					1	Shaft—single worm feed drive. (3-4 Medium Speed Machines)	73422
				919	1	Collar—thrust	65761
				920	1	Washer—lock	3807
				921	1	Nut—lock	3808
				922	1	Cover—top of column. (3-4 Vertical)	67575
				923	2	Cover—strainer hole. Used when coolant pump is omitted	66540

Continued on pages 52 and 53

COLUMN PARTS — Continued



924

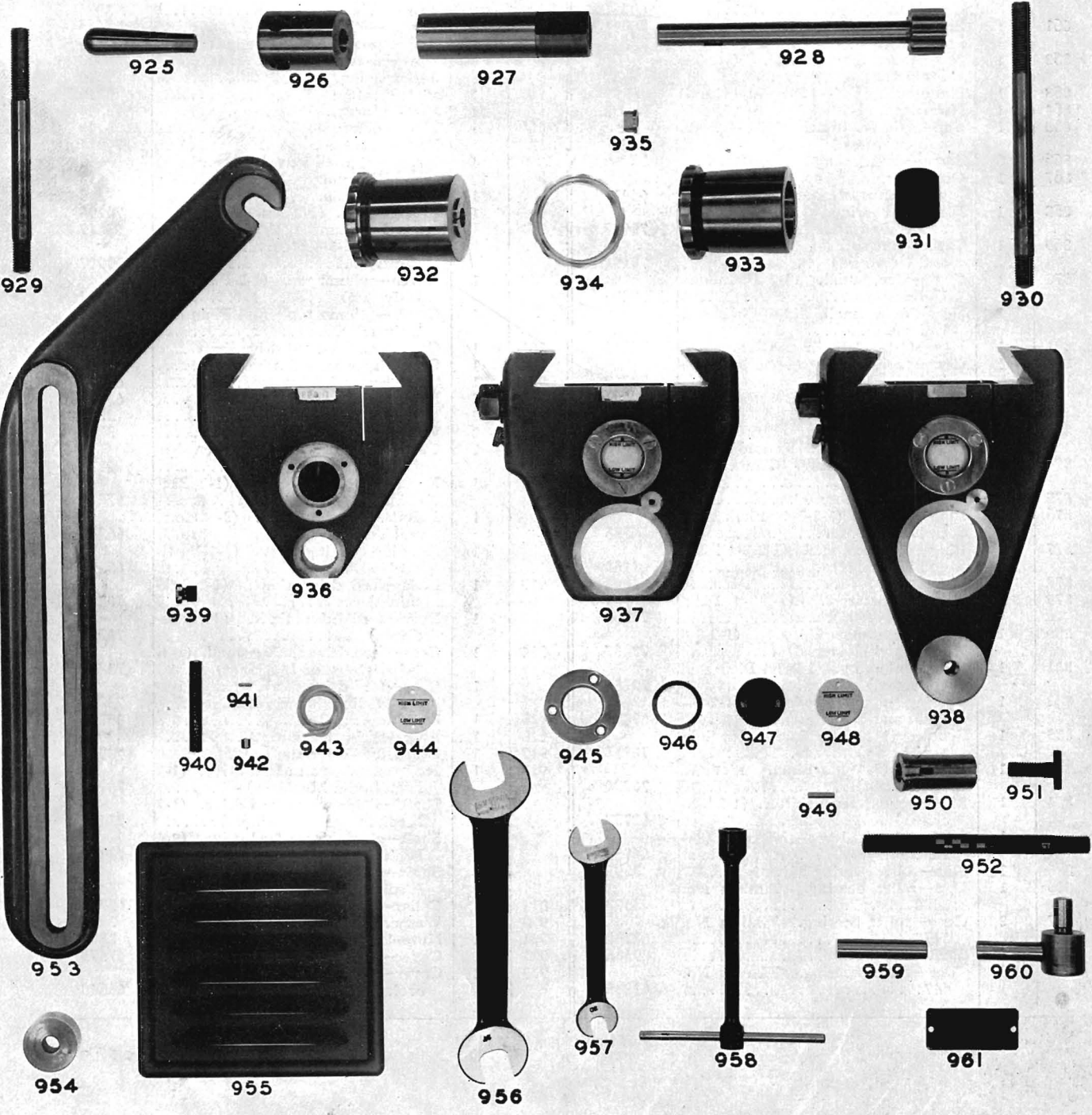

DPC-212



COLUMN PARTS LIST — Concluded

Key No.	Amt. Used	PART NAME	PART NUMBER to use when ordering	Key No.	Amt. Used	PART NAME	PART NUMBER to use when ordering
924	1	Arm—over. (1 Plain and Universal)	69733	938	1	Support—outer. Type B. (3-4 Plain and Universal)	69165
	1	Arm—over. (2 Plain and Universal)	69734	939	1	Plug—pipe, 3/8" dia. (One used for each arbor support)	67608
	1	Arm—over. (3 Plain and Universal Medium Speed, Domestic and Foreign)	69735	940	1	Tube—oil. (One used for each arbor support)	66344
	1	(3 Plain and Universal High Speed Foreign)	69735	941	1	Pin. (One used for each arbor support)	3539
	1	Arm—over. (3 Plain and Universal, Domestic only)	75237	942	1	Plug—in oil tube. (One used for each support)	63561
	1	Arm—over. (4 Plain and Universal)	69736	943	1	Wick—felt. (One for each support)	61416
925	4	Spoke—pilot wheel. (1-2-3-4 Plain and Universal)	3507	944	1	Dial—oil gage. (Used only on support 69164)	60956
926	1	Hub—pilot wheel. (1-2-3-4 Plain and Universal)	3517	945	1	Cover—oil gage	3848
927	1	Bushing—in column. (1-2-3-4 Plain and Universal)	55819	946	3	Gasket—oil gage	3850
928	1	Pinion—stem, pilot wheel. (1-2-3-4 Plain and Universal)	55813	947	1	Disc—oil gage	3849
929	1	Stud—short overarm clamp. (1-2-3-4 Plain and Universal)	66501	948	1	Dial—oil gage. (Used on all supports except 69164)	3851
930	1	Stud—overarm clamp. (1-2-3-4 Plain and Universal)	66502	949	1	Pin—in support	3543
931	1	Washer—overarm clamp stud. (1-2-3-4 Plain and Universal)	62940	950	1	Bush—arbor support. (A type only)	3695
932	1	Adapter—arbor support bush, small. (3-4 Plain and Universal), (shown fitted)	3704	951	1	Screw. (A type only)	3692
933	2	Bush—arbor support. (1-2-3-4 Plain and Universal)	3697	952	1	Stud—in support. (1-2 Plain and Universal)	69168
934	2	Nut—adjusting, arbor support bush. (1-2-3-4 Plain and Universal), (3 used on 3-4 Plain and Universal)	3972	1	1	Stud—in support. (3-4 Plain and Universal)	69169
935	2	Roller. (1-2-3-4 Plain and Universal), (3 used on 3-4 Plain and Universal)	3974	953	2	Brace—overarm. (1-2 Plain and Universal)	67823
936	1	Support—arbor, small. Type A. (1-2 Plain and Universal)	69164	2	2	Brace—overarm. (3-4 Plain and Universal)	67822
	1	Support—arbor, small. Type A. (3-4 Plain and Universal)	69167	954	1	Spacer—overarm brace. (1-2-3-4 Plain and Universal)	62670
937	1	Support—inner. Type B. (1-2 Plain and Universal)	69163	955	2	Cover—louvre	64658
	1	Support—inner. Type B. (3-4 Plain and Universal)	69166	956	1	Wrench—5/8" and 3/4" nut	3957
938	1	Support—outer. Type B. (1-2 Plain and Universal)	69162	957	1	Wrench—double end	19476
				958	1	Wrench—socket for dogs	39270
				959	2	Pin—hinge support	69806
				960	2	Hinge—cover. (1-2-3-4 machines except those listed below)	69805
					2	Hinge—cover. (3 Horz. High Speed 7 1/2 and 10 H.P. motor Domestic), (4 Horz. and Vert., Domestic and Foreign)	69861
				961	1	Plate—feed instruction. (1-2-3-4 High Speed.) English	73902

# KNEE UNIT PARTS

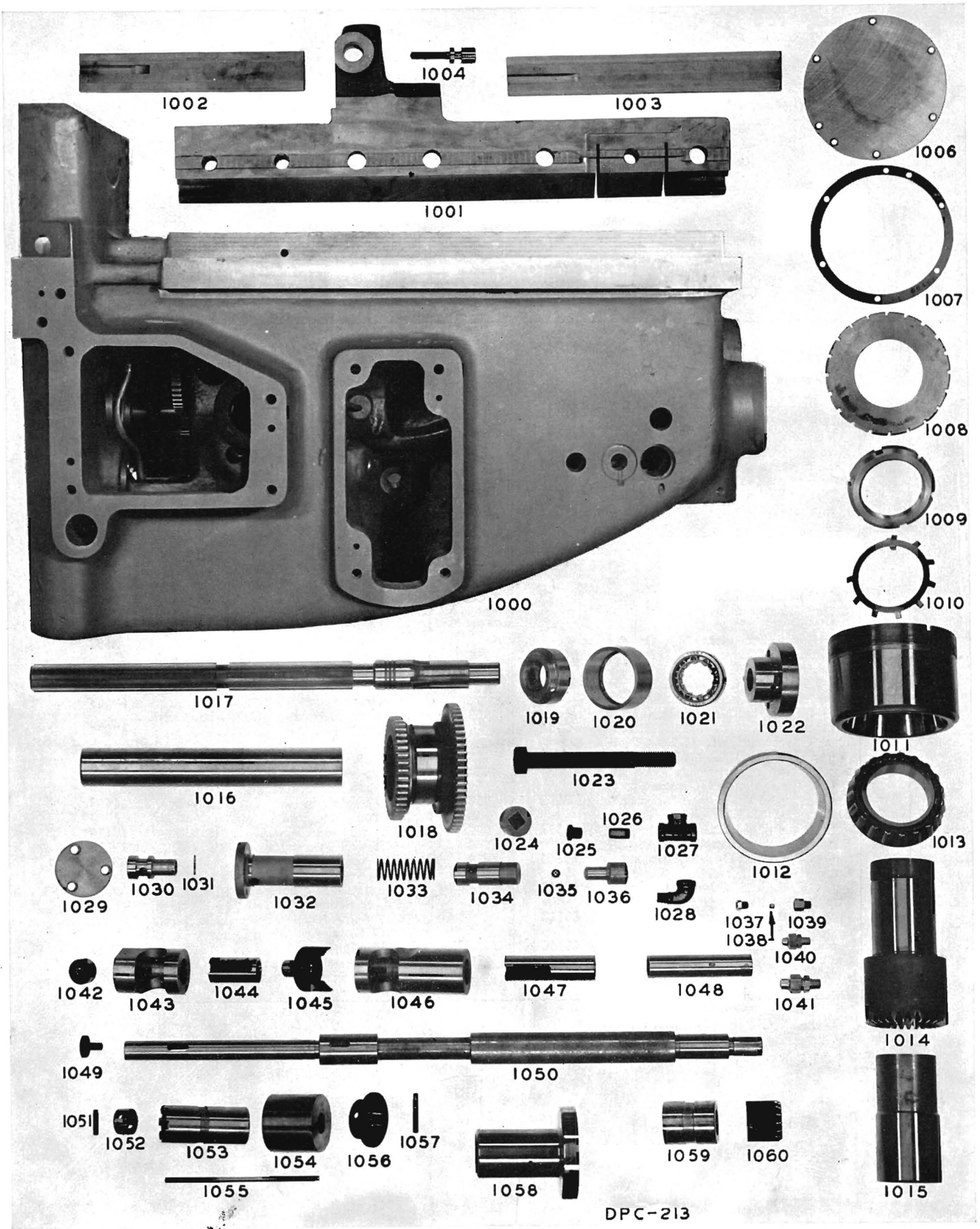

DPC-213

KNEE UNIT PARTS LIST

Key No.	Amt. Used	PART NAME	PART NUMBER to use when ordering	Key No.	Amt. Used	PART NAME	PART NUMBER to use when ordering
1000	1	Knee—(#1 Plain and Universal) . . .	73425	1025	2	Bushing—reducing. 1/4" to 1/8" pipe.	58197
	1	Knee—(#2 Plain and Universal), (#1 and 2 Vertical) . . . . .	73426	1026	3	Nipple—1/4" x 1/8" pipe . . . . .	10048
	1	Knee—(#3 Plain and Universal) . . .	73389	1027	2	Tee—1/4" pipe . . . . .	13660
	1	Knee—(#3 and #4 Vertical), (#4 Plain and Universal) . . . . .	73427	1028	1	Elbow—street. 1/4" pipe . . . . .	12838
1001	1	Guide—for knee. (1-2 Plain, Universal and Vertical) . . . . .	69816	1029	1	Cap—oil pump . . . . .	53848
	1	Guide—for knee. (3-4 Plain, Universal and Vertical) . . . . .	69186	1030	1	Valve—oil pump . . . . .	53777
1002	1	Gib—bottom. (1-2 Plain, Universal and Vertical) . . . . .	69532	1031	1	Stop—oil pump ball . . . . .	53754
	1	Gib—bottom. (3-4 Plain, Universal and Vertical) . . . . .	69178	1032	1	Sleeve—oil pump . . . . .	53778
1003	1	Gib—top. (1-2 Plain, Universal and Vertical) . . . . .	70889	1033	1	Spring . . . . .	52672
	1	Gib—top. (3-4 Plain, Universal and Vertical) . . . . .	70888	1034	1	Plunger—oil pump. (fitted with plug and ball) . . . . .	52653FB
1004	2	Screw—gib adjusting . . . . .	63606	1035	1	Ball—1/16" diameter . . . . .	29019
1005	1	Gasket—for guide on knee . . . . .	66972	1036	1	Plug—oil pump plunger . . . . .	70299
1006	1	Cover—vertical screw . . . . .	73376	1037	1	Nut . . . . .	60721
1007	1	Gasket—vertical screw cover . . . . .	66468	1038	1	Sleeve . . . . .	60720
1008	1	Nut—roller bearing adjusting . . . . .	63167	1039	1	Adapter . . . . .	60719
1009	1	Nut—lock . . . . .	3798	1040	1	Union—compression, 1/4" tubing . . . . .	89866
1010	1	Washer—lock . . . . .	3797	1041	2	Union—compression, 3/8" tubing . . . . .	57287
1011	1	Retainer—roller bearing. (fitted with 2-63169 cups) . . . . .	63187	1042	2	Plug—in disengaging shaft bush—1/8" diameter . . . . .	73411
1012	2	Cup—roller bearing. Timken No. 472B . . . . .	63169	1043	1	Bushing . . . . .	74758
1013	2	Cone—roller bearing. Timken No. 482 . . . . .	63168	1044	1	Stem . . . . .	74756
1014	1	Gear—bevel vertical screw . . . . .	63171	1045	2	Crank—knock out . . . . .	74755
1015	1	Tube—oil retainer in knee . . . . .	63170	1046	1	Bush—shaft clutch, cross control . . . . .	73413
1016	1	Cover—spline shaft. (1 Plain and Universal) . . . . .	67413	1047	1	Stem . . . . .	74757
	1	Cover—spline shaft. (1-2 Vertical), (2 Plain), (3 Plain and Universal) . . . . .	67414	1048	1	Sleeve—in clamp bolt hole . . . . .	68345
	1	Cover—spline shaft. (2 Universal) . . . . .	67415	1049	2	Screw . . . . .	3514
	1	Cover—spline shaft. (3-4 Vertical), (4 Plain) . . . . .	67416	1050	1	Shaft—elevating, front. (1 Plain and Universal) . . . . .	73541
	1	Cover—spline shaft. (4 Universal) . . . . .	67417			Shaft—elevating, front. (1-2 Vertical), (2 Plain and Universal) . . . . .	73462
1017	1	Shaft—long spline. (1 Plain and Universal) . . . . .	78311			Shaft—elevating, front. (3 Plain and Universal) . . . . .	73395
	1	Shaft—long spline. (1-2 Vertical), (2-3 Plain and Universal) . . . . .	78309	1051	2	Shaft—elevating, front. (3-4 Vertical), (4 Plain and Universal) . . . . .	73455
	1	Shaft—long spline. (3-4 Vertical), (4 Plain and Universal) . . . . .	78310	1952	2	Pin—in collar, short . . . . .	66254
1018	1	Gear—eccentric long spline shaft . . . . .	70302	1053	1	Collar—small . . . . .	66249
1019	1	Seal—roller bearing . . . . .	78308	1054	1	Clutch—elevating shaft . . . . .	73397
1020	1	Retainer—bearing . . . . .	74750	1054	1	Bush—large on elevating shaft . . . . .	73408
1021	1	Bearing—roller. Hyatt No. 1305T . . . . .	74754	1055	1	Rod—knock out elevating shaft. (1 Plain and Universal) . . . . .	73537
1022	1	Bearing—long spline shaft . . . . .	71825			Rod—knock out elevating shaft. (1-2 Vertical), (2 Plain and Univ.) . . . . .	73461
1023	1	Bolt—clamp for guide . . . . .	63658			Rod—knock out elevating shaft. (3 Plain and Universal) . . . . .	73396
1024	1	Plug—pipe, 1" diameter . . . . .	52823	1056	2	Rod—knock out elevating shaft. (3-4 Vertical), (4 Plain and Univ.) . . . . .	73452
				1057	2	Collar—flange . . . . .	66255
				1058	1	Pin—in collar, long . . . . .	66253
						Dial—on elevating shaft. (English) . . . . .	70270
						Dial—on elevating shaft. (Metric) . . . . .	78724
				1059	1	Bushing—small on elevating shaft . . . . .	62712
				1060	1	Gear—bevel on elevating shaft . . . . .	62713

Continued on pages 56 and 57

KNEE UNIT PARTS — Continued

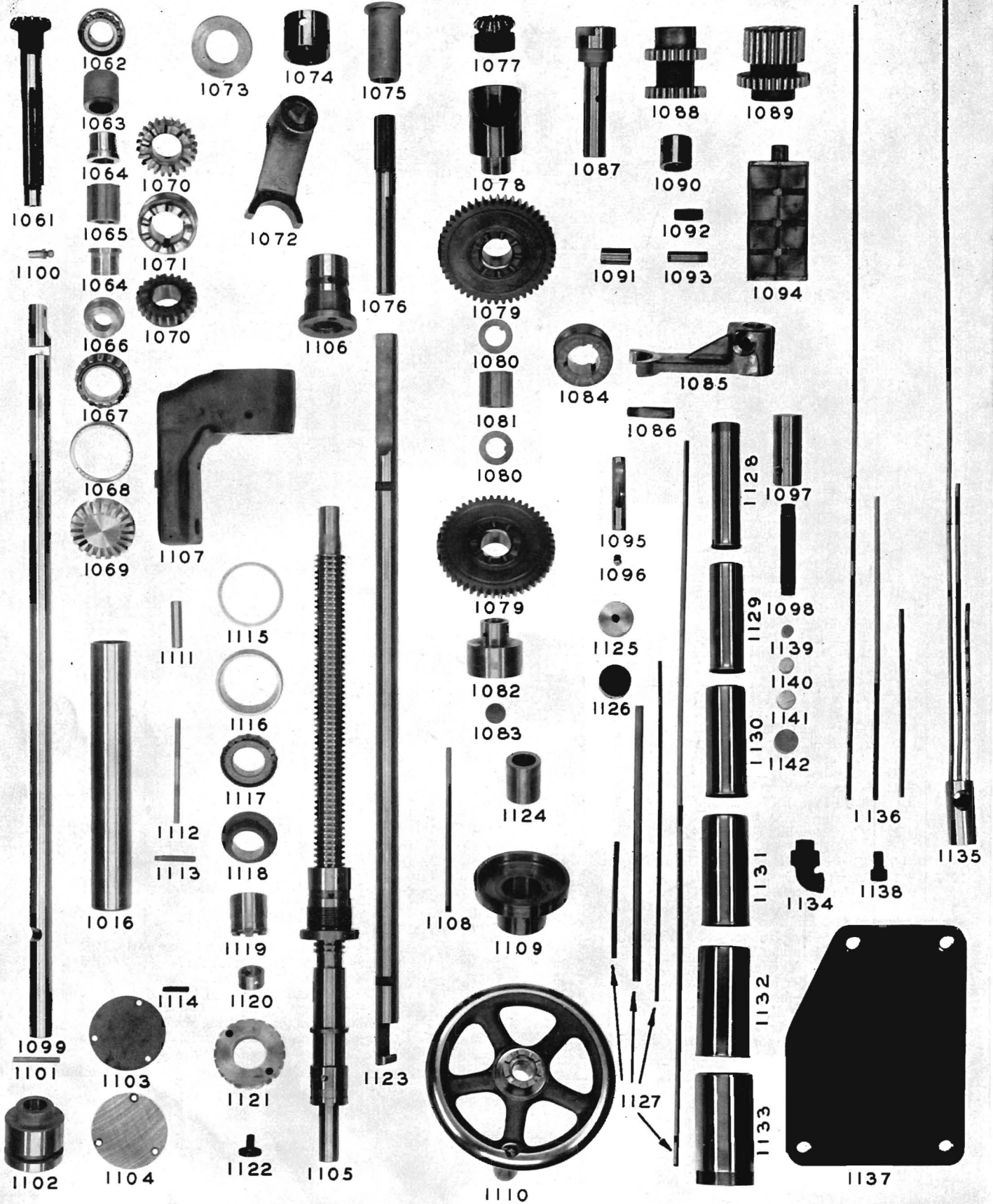

DPC-214



KNEE UNIT PARTS LIST—Continued

Key No.	Amt. Used	PART NAME	PART NUMBER to use when ordering	Key No.	Amt. Used	PART NAME	PART NUMBER to use when ordering
1061	1	Gear—elevating stem bevel.....	69184	1111	1	Pin—stop. (2-4 Plain and Vertical)	69713
1062	1	Bearing—roller.....	67013		1	Pin—stop. (1 Plain and Vertical), (3 Plain and Vertical).....	69718
1063	1	Sleeve—elevating bevel gear pinion.....	62908	1112	1	Rod—knock out, cross. (1-2 Plain, Universal and Vertical).....	73460
1064	2	Bushing—elevating stem bevel gear.....	62914		1	Rod—knock out, cross. (3-4 Plain, Universal and Vertical).....	73407
1065	1	Sleeve—elevating clutch.....	62915	1113	2	Pin—in collar, long.....	66253
1066	1	Sleeve—on elevating stem bevel gear.....	69181	1114	2	Pin—in collar, short.....	66254
1067	1	Cone—roller bear'g. Timken 19150.....	69189	1115	1	Spacer—cross screw roller bearing.....	73431
1068	1	Cup—roller bearing. Timken 19268.....	69188	1116	2	Cup—roller bearing. Timken 19283.....	58870
1069	1	Nut—bearing lock.....	69182	1117	2	Cone—roller bearing. Timken 19138.....	58871
1070	2	Gear—clutch elevat'g stem bevel gear.....	62918	1118	2	Collar—flange.....	66255
1071	1	Clutch—elevating stem bevel gear.....	62917	1119	1	Clutch—cross screw.....	73403
1072	1	Fork—elevating clutch.....	68847	1120	2	Collar—small.....	66249
1073	1	Collar—dust, cross feed screw.....	66245	1121	1	Nut—bearing retainer.....	62715
1074	1	Sleeve—felt retainer.....	62721	1122	2	Screw.....	3514
1075	1	Coupling—cross screw.....	66573	1123	1	Rod—cross feed shifter. (1 Pl. & Un.)	73543
1076	1	Shaft—cross feed.....	65766		1	Rod—cross feed shifter. (1-2 Verti- cal), (2 Plain and Universal).....	73464
1077	1	Gear—cross feed shaft.....	67973		1	Rod—cross feed shifter. (3 Pl. & Un.)	73398
1078	1	Bushing—cross feed shaft.....	67972		1	Rod—cross feed shifter. (3-4 Verti- cal), (4 Plain and Universal).....	73454
1079	2	Gear—clutch cross feed shaft.....	62924	1124	1	Bushing—rod cross feed shifter.....	67337
1080	2	Collar—thrust.....	65761	1125	2	Plug—1 1/2" dia. x 1/2" long.....	73812
1081	1	Sleeve—cross feed clutch.....	65762	1126	2	Plug—1 3/8" diameter.....	3827
1082	1	Bearing—cross feed shaft.....	69180	1127	1	Tubing—oil. (1-2 Pl. & Un.).....	66282
1083	2	Plug.....	3550		1	Tubing—oil. (1-2 Vt.), (2 Pl. & Un.)	66283
1084	1	Clutch—cross feed.....	62916		1	Tubing—oil. (3 Plain and Universal)	66284
1085	1	Fork—cross feed clutch.....	68844		1	Tubing—oil. (3-4 Vt.), (4 Pl. & Un.)	66285
1086	2	Pin—lock. 1/2" dia. x 2 1/16" long.....	48073	1128	1	Tube—telescopic, first. (1-2 Verti- cal), (1-2 Universal).....	68244
1087	2	Shaft—cross and elevat'g, secondary.....	69170		1	Tube—telescopic, first. (1-2 Plain), (3-4 Plain, Universal and Vertical)	63348
1088	1	Gear—small cross feed and elevating.....	70298	1129	1	Tube—telescopic, second. (1-2 Verti- cal), (1-2 Universal).....	68245
1089	1	Gear—large cross feed and elevating.....	70297		1	Tube—telescopic, second. (1-2 Plain), (3-4 Pl., Un. & Vt.).....	63351
1090	4	Bushing.....	3603	1130	1	Tube—telescopic, third. (1-2 Verti- cal), (1-2 Universal).....	68246
1091	1	Pin—stop.....	68999		1	Tube—telescopic, third. (1-2 Plain), (3-4 Plain, Universal and Vertical)	63350
1092	1	Nipple—1/4" x 1 1/4" pipe.....	63162	1131	1	Tube—telescopic, fourth. (1-2 Verti- cal), (1-2 Universal).....	68247
1093	1	Nipple—union to knee.....	63345		1	Tube—telescopic, fourth. (1-2 Plain) (3-4 Plain, Universal and Vertical)	63349
1094	1	Strainer.....	65540	1132	1	Tube—telescopic, fifth. (1-2 Verti- cal), (1-2 Universal).....	68248
1095	1	Plug—oil slotted.....	75465		1	Tube—telescopic, fifth. (1-2 Plain), (3-4 Plain, Universal and Vertical)	63347
1096	1	Plug.....	75466	1133	1	Tube—telescopic, sixth. (1-2 Verti- cal), (1-2 Universal).....	68249
1097	1	Plug—oil sprayer.....	69494		1	Tube—telescopic, sixth. (1-2 Plain), (3-4 Plain, Universal and Vertical)	63346
1098	1	Pipe—oil sprayer in plug.....	69493	1134	1	Elbow—Union. 1/4" pipe.....	61678
1099	1	Rod—vertical feed shifter. (1 Plain and Universal).....	73542	1135	1	Plug—oil. Fitted with tubing 68941. (1 Plain and Universal).....	63072
	1	Rod—vertical feed shifter. (1-2 Verti- cal), (2 Plain and Universal).....	73463	1136	1	Tubing—oil. (1 Plain and Universal)	68941
	1	Rod—vertical feed shifter. (3 Plain and Universal).....	73399	1135	1	Plug—oil. Fitted with tubing 68942. (1-2 Vt.), (2 Pl. & Un.).....	63072
	1	Rod—vertical feed shifter. (3-4 Verti- cal), (4 Plain and Universal).....	73453	1136	1	Tubing—oil. (1 Plain and Universal)	68941
1100	1	Shifter—ball, vertical shifter. (3-4 Plain, Universal and Vertical).....	66259	1135	1	Plug—oil. Fitted with tubing 68942. (1-2 Vertical), (2 Plain and Univ.)	63072
1101	1	Pin.....	63630	1136	1	Tubing—oil. (1-2 Vt.), (2 Pl. & Un.)	68942
1102	1	Sleeve—vertical feed shifter rod.....	63613	1135	1	Plug—oil. Fitted with tubing 68943. (3 Plain and Universal).....	63072
1103	1	Gasket—vert. feed shifter rod cover.....	70462	1136	1	Tubing—oil. (3 Plain and Universal)	68943
1104	1	Cover—vertical feed shifter rod.....	63614	1135	1	Plug—oil. Fitted with tubing 68944. (3-4 Vertical), (4 Plain and Univ.)	63072
1105	1	Screw—cross. (English) fitted with nut. (1 Plain and Universal).....	73539	1136	1	Tubing—oil. (3-4 Vt.), (4 Pl. & Un.)	68944
	1	Screw—cross. (Metric) fitted with nut. (1 Plain and Universal).....	73540	1137	1	Cover—rear control pad. (1-2-3-4 Vertical or on all machines where rear control bracket is omitted)...	73915
	1	Screw—cross. (English) fitted with nut. (1-2 Vertical), (2 Pl. & Un.)	73466	1138	4	Screw. (Used when rear control bracket is omitted).....	216052
	1	Screw—cross. (Metric) fitted with nut. (1-2 Vertical), (2 Pl. & Un.)	73467	1139	1	Plug—1/2" diameter.....	3529
	1	Screw—cross. (English) fitted with nut. (3 Plain and Universal).....	73393	1140	3	Plug—3/8" diameter.....	3530
	1	Screw—cross. (Metric) fitted with nut. (3 Plain and Universal).....	73394	1141	1	Plug—3/4" diameter.....	3549
	1	Screw—cross. (English) fitted with nut. (3-4 Vertical), (4 Pl. & Un.)	73457	1142	2	Plug—1" diameter.....	3551
	1	Screw—cross. (Metric) fitted with nut. (3-4 Vertical), (4 Pl. & Un.)	73458				
1106	1	Nut—cross screw. (English).....	65768				
1107	1	Nut—cross screw. (Metric).....	65769				
1108	1	Bracket—nut under saddle.....	65770				
1109	1	Tube—oil.....	67864				
	1	Dial—on cross screw. (English).....	73401				
	1	Dial—on cross screw. (Metric).....	78726				
1110	1	Wheel—hand.....	73405				
1111	1	Pin—stop. (1 Pl. & Vt.), (3 Vt.)...	69717				
	1	Pin—stop. (2-4 Plain and Universal)	69716				
	1	Pin—stop. (1-3 Universal).....	69715				
	1	Pin—stop. (2-4 Universal).....	69714				

Continued on pages 58 and 59

KNEE UNIT PARTS — Continued

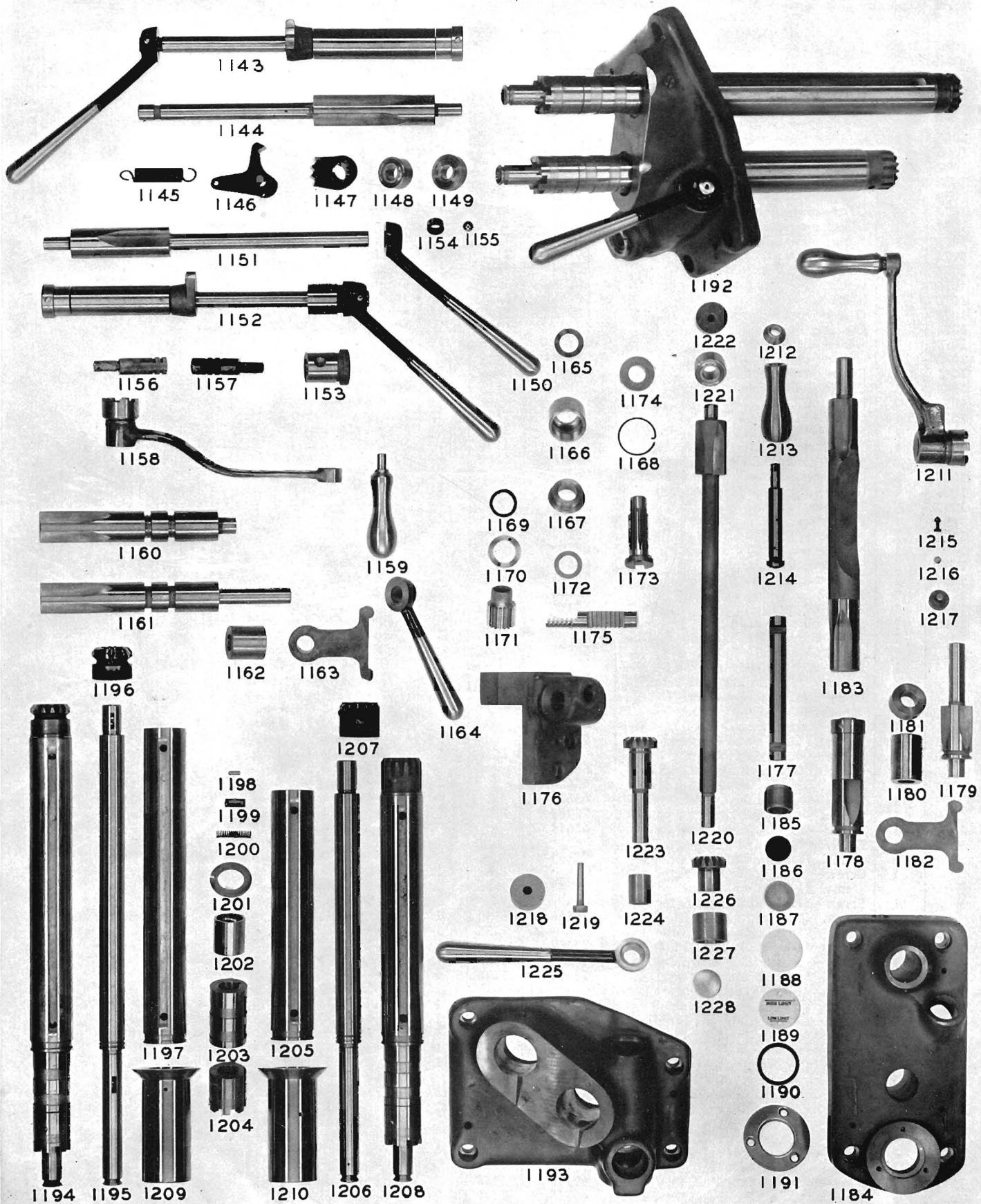

DPC-215



KNEE UNIT PARTS LIST—Continued

Key No.	Amt. Used	PART NAME	PART NUMBER to use when ordering	Key No.	Amt. Used	PART NAME	PART NUMBER to use when ordering
1143	1	Shaft—cross feed shifter. Fitted. (1-2 Machines).....	68361F	1181	1	Collar.....	3815
	1	Shaft—cross feed shifter. Fitted. (3-4 Machines).....	68324F	1182	1	Lever—trip, cross and vertical feed.....	71784
1144	1	Shaft—cross feed shifter. (1-2 Machines).....	68361	1183	1	Shaft—cross feed trip.....	67344
	1	Shaft—cross feed shifter. (3-4 Machines).....	68324	1184	1	Bracket—trip, cross feed.....	67345
1145	1	Spring.....	3959	1185	1	Nipple—oil filler.....	3912
1146	2	Lever—detent.....	59626	1186	1	Gasket—oil filler cap.....	77845
1147	2	Detent—shifter shaft.....	63611	1187	1	Cap—oil filler.....	3986
1148	2	Bushing.....	68364	1188	1	Disc—oil gauge.....	3849
1149	2	Collar.....	68363	1189	1	Dial—oil gauge.....	60956
1150	2	Lever—bent.....	67838	1190	3	Gasket—oil gauge.....	3850
1151	1	Shaft—vertical feed shifter. (1-2 Machines).....	75507	1191	1	Cover—oil gauge.....	3848
	1	Shaft—vertical feed shifter. (3-4 Machines).....	75418			The following parts are used when Rear Control Bracket is supplied:	
1152	1	Shaft—vertical feed shifter. (1-2 Machines) fitted.....	75507F	1192	1	Bracket—rear control. Fitted complete.....	74331F
	1	Shaft—vertical feed shifter. (3-4 Machines) fitted.....	75418F	1193	1	Bracket—rear control.....	74331
1153	1	Bushing.....	75417	1194	1	Shaft—cross feed. Fitted.....	68421F
1154	1	Bushing—interlock for ball.....	63615	1195	1	Shaft—cross.....	68421
1155	1	Ball— $\frac{1}{2}$ " diameter.....	36147	1196	1	Gear—cross and elevating feed.....	67973
1156	1	Stud—detent lever, cross feed.....	67768	1197	1	Sleeve—cross shaft. Fitted with two 3818 bushings.....	63063
1157	1	Stud—detent lever, vertical feed.....	67767	1198	2	Pin—crank and elevating shaft.....	63067
1158	1	Crank—hand.....	66262	1199	2	Pin—crank handle.....	63079
1159	1	Handle—spool.....	3505F	1200	2	Spring.....	3942
1160	1	Shaft—elevating trip. (Used when rear control bracket is omitted).....	70850	1201	2	Washer.....	62714
1161	1	Shaft—elevating trip. (Used on all machines equipped with rear control bracket).....	63620	1202	4	Bushing.....	3818
1162	1	Spacer—elevating trip shaft.....	64328	1203	2	Sleeve—dial.....	68730
1163	1	Lever—trip, cross and vertical feed.....	71784	1204	2	Clutch.....	38125
1164	1	Lever—elevating feed trip shaft.....	63612	1205	1	Sleeve—elevating shaft.....	63064
1165	2	Coupling—shaft.....	67108	1206	1	Shaft—elevating.....	68422
1166	2	Sleeve—coupling.....	67102	1207	1	Gear—bevel on elevating shaft.....	62713
1167	2	Plug—screw coupling sleeve.....	67109	1208	1	Shaft—elevating. Fitted.....	68422F
1168	3	Spring—ring.....	67620	1209	1	Dial—cross shaft. English.....	68733
1169	2	Ring—felt, quick traverse bracket.....	66455	1210	1	Dial—cross shaft. Metric.....	78728
1170	2	Screw—pinion rear control.....	67099	1211	1	Dial—elevating shaft. English.....	70271
1171	2	Pinion—vertical, rear control.....	67098	1212	1	Dial—elevating shaft. Metric.....	78727
1172	1	Washer—thrust in guide.....	67100	1213	1	Crank—handle. Fitted.....	63065F
1173	2	Pinion—horizontal, rear control. Fitted with pin 3636.....	67101	1214	1	Collar—spool.....	3504
1174	2	Collar.....	3815	1215	1	Handle—spool.....	3505
1175	2	Rack—rear control.....	67096	1216	1	Stud—spool.....	3503
1176	1	Bracket—feed and speed control.....	74134	1217	1	Plunger—in crank.....	63068
1177	1	Rod—bracket trip.....	63291	1218	1	Plug—small in crank handle.....	63070
1178	1	Shaft. Fitted with bushing 67336 and collar 3815.....	67335F	1219	1	Plug—large in crank handle.....	63074
1179	1	Shaft.....	67335	1220	1	Plug— $1\frac{1}{2}$ " diameter.....	3553
1180	1	Bushing.....	67336	1221	2	Pin—taper.....	83432
				1222	1	Shaft—cross feed control.....	69575
				1223	1	Bushing.....	68364
				1224	1	Plug— $1\frac{3}{8}$ " diameter.....	3827
				1225	1	Gear—mitre, rear cross control.....	74332
				1226	1	Bushing.....	3564
				1227	1	Handle—straight.....	67839
				1228	1	Gear—mitre, rear cross control shaft.....	69574
						Bushing—mitre gear.....	77693
						Plug—expansion. $1\frac{1}{4}$ " diameter.....	69448

Continued on pages 60 and 61

KNEE UNIT PARTS — Continued



1253



1254



1255



1256

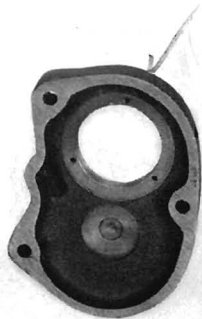

1257



1258

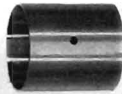

1259

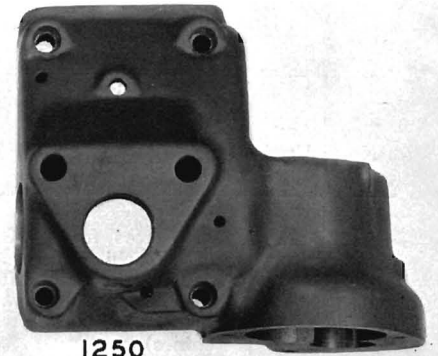

1250



1260



1261



1262



1263



1264



1266



1267



1269



1270



1271



1268



1276



1277



1265



1272



1273



1274



1275



1278



1279



1280



1281



1282



1283



1284



1285



1286



1288



1287

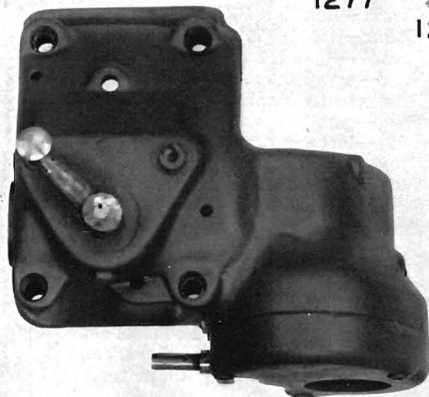

1251

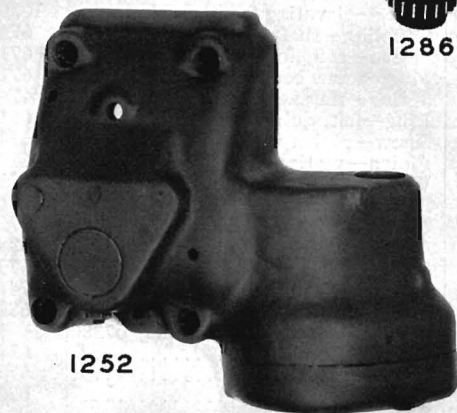

1252

DPC-202

KNEE UNIT PARTS LIST—Concluded

Key No.	Amt. Used	PART NAME	PART NUMBER to use when ordering	Key No.	Amt. Used	PART NAME	PART NUMBER to use when ordering
1250	1	Bracket—change gear.....	71790	1269	1	Plug—1" diameter.....	74802
1251	1	Bracket—change gear. (Hi-Speed Machines) Fitted complete.....	71790RFA	1270	2	Plug— $\frac{3}{4}$ " diameter. Medium Speed Machines.....	3549
1252	1	Bracket—change gear. (Medium Speed Machines) Fitted complete.....	71790RFB	1271	1	Plug— $\frac{1}{2}$ " diameter.....	3529
1253	1	Flange—tube retainer.....	66964	1272	1	Shaft—eccentric. High Speed Machines.....	70293
1254	1	Nipple—union to knee.....	63345	1273	1	Bushing—eccentric shaft. High Speed Machines.....	70292
1255	1	Union— $\frac{1}{4}$ " pipe.....	13656	1274	2	Stop—High Speed Machines.....	50365
1256	1	Nipple— $\frac{1}{4}$ " pipe.....	10048	1275	1	Lever—gear shifter. High Speed Machines. (Fitted).....	35193
1257	1	Cover—change gear bracket.....	67120	1276	1	Pin—High Speed Machines.....	29366
1258	1	Bearing—ball. New Departure No. 5206.....	70656	1277	1	Spring—High Speed Machines.....	84157
1259	1	Bushing—mitre gear.....	74788	1278	1	Plate—Instruction feed change. English. High Speed Machines.....	70986
1260	1	Plug—in ball bearing adapter.....	74783	1279	1	Plug—position gear. Medium Speed Machines.....	73419
1261	1	Sleeve—ball bearing.....	74785	1280	1	Pin—position gear. Medium Speed Machines.....	73420
1262	2	Bearing—ball. S.K.F. No. 6206.....	53388	1281	1	Gear—mitre in change gear bracket.....	74786
1263	1	Adapter—ball bearing.....	74784	1282	1	Bearing—ball. S.K.F. 6206.....	53388
1264	1	Shaft—mitre gear.....	74816	1283	1	Bushing.....	3832
1265	1	Gear—sliding.....	70296	1284	1	Shaft—change gear bracket.....	63357
1266	1	Gear—mitre in bracket.....	74782	1285	1	Bearing—mitre gear.....	74787
1267	1	Dial—feed. English. High feed series. $\frac{1}{2}$ " to 20".....	63212	1286	1	Gear—feed. 24 Teeth. Standard series.....	63355
	1	Dial—feed. Metric. High feed series. 13 to 508 mm.....	65419			Gear—feed. 33 Teeth. Low series..	63353
	1	Dial—feed. English. Low feed series. $\frac{1}{4}$ " to 10".....	65537			Gear—feed. 19 Teeth. High series. Medium Speed Machines only....	63356
	1	Dial—feed. Metric. Low feed series. 6 to 254 mm.....	65539	1287	1	Gear—feed. 28 Teeth. Standard series.....	63361
	1	Dial—feed. English. High feed series. $\frac{3}{4}$ " to 30". This dial is for Medium Speed Machines only....	65538			Gear—feed. 19 Teeth. Low series..	63360
	1	Dial—feed. Metric. High feed series. 19 to 762 mm. This dial is for Medium Speed Machines only....	65535			Gear—feed. 33 Teeth. High series. Medium Speed Machines only....	63354
1268	1	Plate—center. American built.....	71830	1288	1	Bushing.....	63344
	1	Plate—center. English built.....	71831				

# SADDLE, TABLE, HOUSING UNIT PARTS

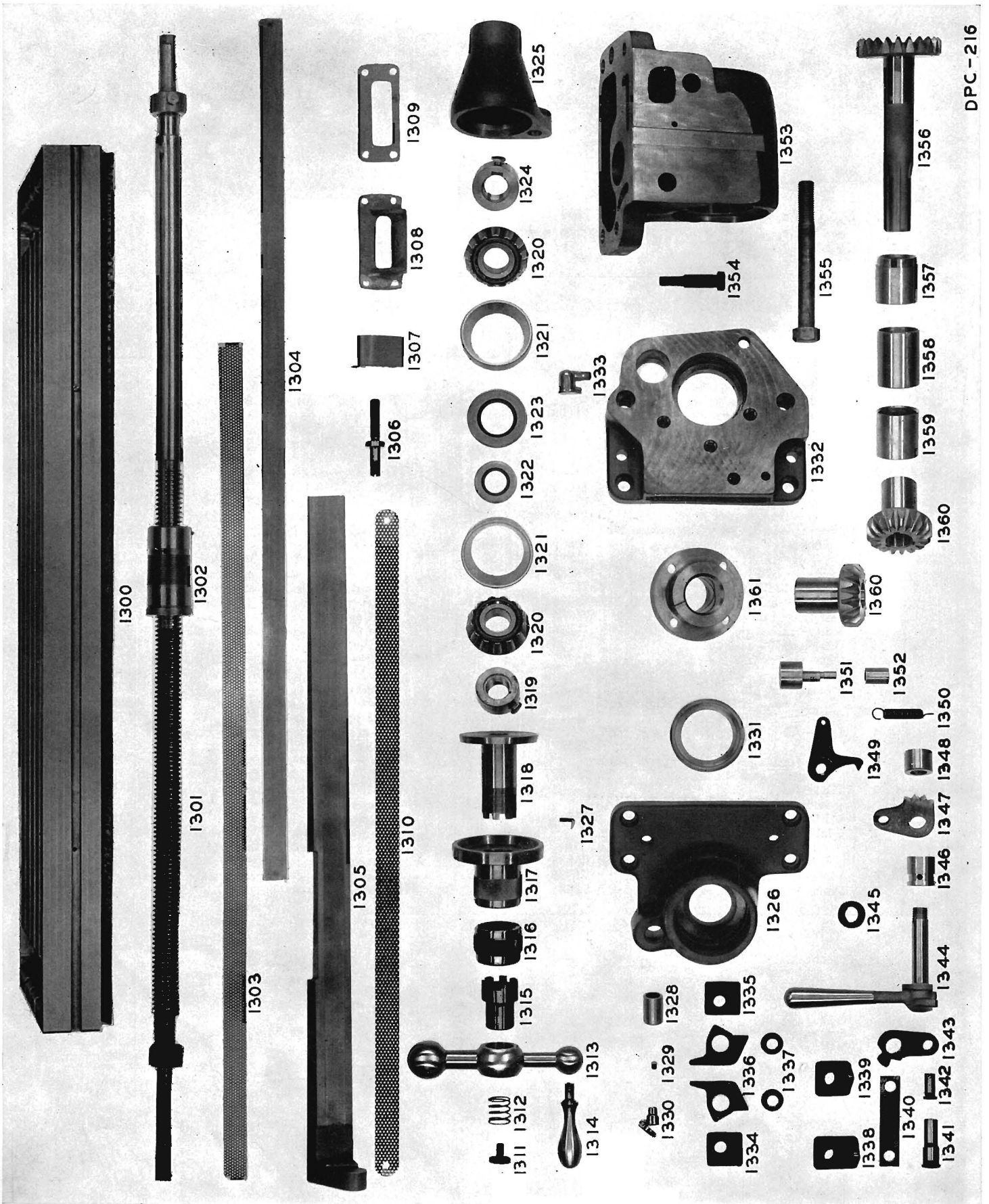

DPC-216



## SADDLE, TABLE, HOUSING UNIT PARTS LIST

Key No.	Amt. Used	PART NAME	PART NUMBER to use when ordering	Key No.	Amt. Used	PART NAME	PART NUMBER to use when ordering
1300	1	Table. (1 Pl., Un. & Vt.)	69111	1314	1	Handle—large	3502
	1	Table. (2 Pl., Un. & Vt.)	69112	1315	1	Clutch—for ball crank	3506
	1	Table. (3 Pl., Un. & Vt.)	69113	1316	1	Nut—dial clamping	36436
	1	Table. (4 Pl., Un. & Vt.)	69114	1317	1	Dial. English	67736
	1	Table. (2 Plain and Vertical. 36" table travel)	93148	1318	1	Dial. Metric	78725
	1	Table. (3 Plain and Vertical. 42" table travel)	78447	1319	1	Clutch—on lead screw	33747
1301	1	Screw—lead. (1 Plain, Universal and Vertical) English. All lead screws are fitted with nut for that particular screw, and with two lock nuts	77346	1320	2	Nut—lock on lead screw	68707
	1	Screw—lead. (1 Plain, Universal and Vertical) Metric	77347	1321	2	Cone—roller bearing. Timken No. 43112	63695
	1	Screw—lead. (2 Plain, Universal and Vertical) English	77349	1322	2	Cup—roller bearing. Timken No. 43312	63696
	1	Screw—lead. (2 Plain, Universal and Vertical) Metric	77350	1323	1	Seal—oil, for front apron	3998
	1	Screw—lead. (3 Plain, Universal and Vertical) English	77352	1324	1	Seal—oil, for back apron	65628
	1	Screw—lead. (3 Plain, Universal and Vertical) Metric	77353	1325	1	Nut—lock on lead screw	69290
	1	Screw—lead. (4 Plain, Universal and Vertical) English	77355	1326	1	Cover—on back apron	78072
	1	Screw—lead. (4 Plain, Universal and Vertical) Metric	77356	1327	1	Apron—front. (1-2 Plain, Universal and Vertical)	78998
	1	Screw—lead. (2 Plain and Vertical. 36" table travel) English	79957	1328	1	Apron—front. (3-4 Plain, Universal and Vertical)	78663
	1	Screw—lead. (2 Plain and Vertical. 36" table travel) Metric	79956	1329	1	Pointer—for dial	33745
	1	Screw—lead. (3 Plain and Vertical. 42" table travel) English	71865	1330	1	Bushing	3963
	1	Screw—lead. (3 Plain and Vertical. 42" table travel) Metric	79935	1331	1	Oiler	60062
1302	1	Nut—on lead screw. English	68491	1332	1	Oiler	51737
	1	Nut—on lead screw. Metric	70261	1332	2	Ring—oil retainer in apron	66636
1303	1	Strainer—long for table. (#1 Machines)	63784	1333	1	Apron—back. (1-2 Plain, Universal and Vertical)	75322
	1	Strainer—long for table. (#2 Machines)	63788	1334	1	Apron—back. (3-4 Plain, Universal and Vertical)	75703
	1	Strainer—long for table. (#3 Machines)	63847	1335	1	Oiler	44979
	1	Strainer—long for table. (#4 Machines)	63851	1336	1	Dog—trip, quick traverse. L. H. (1-2-3-4 Plain and Vertical)	63663
	1	Strainer—long for table. (#2 Plain and Vertical. 36" table travel)	93144	1337	2	Dog—trip, quick traverse. R. H. (1-2-3-4 Plain and Vertical)	63661
	1	Strainer—long for table. (#3 Plain and Vertical. 42" table travel)	67056	1338	1	Dog—trip, quick traverse. (1-2-3-4 Plain and Vertical)	63679
1304	1	Cover—strainer long for table. (#1 Machines)	63785	1339	1	Bushing—trip dog, quick traverse. (1-2-3-4 Plain and Vertical)	63656
	1	Cover—strainer long for table. (#2 Machines)	63787	1340	1	Dog—feed. L. H.	63662
	1	Cover—strainer long for table. (#3 Machines)	63848	1341	1	Dog—feed. R. H.	63660
	1	Cover—strainer long for table. (#4 Machines)	63850	1342	1	Link—table feed control. (1 Plain, Universal and Vertical)	63495
	1	Cover—strainer long for table. (#2 Plain and Vertical. 36" table travel)	93143	1343	1	Link—table feed control. (2 Plain, Universal and Vertical)	63764
	1	Cover—strainer long for table. (#3 Plain and Vertical. 42" table travel)	67057	1344	1	Link—table feed control. (3 Plain, Universal and Vertical)	64001
1305	1	Gib—table. (1 Pl., Un. & Vt.)	67843	1345	1	Link—table feed control. (4 Plain, Universal and Vertical)	64002
	1	Gib—table. (2 Pl., Un. & Vt.)	66496	1346	1	Stud—clutch shifter	63493
	1	Gib—table. (3 Pl., Un. & Vt.)	66497	1347	2	Pin—table feed control link	63494
	1	Gib—table. (4 Pl., Un. & Vt.)	66498	1348	1	Lever—front table feed trip	63512
1306	1	Screw—gib	3997	1349	1	Lever—table feed trip	69621
1307	1	Guard—table gib	67741	1350	1	Nut—on table feed trip lever	41319
1308	1	Spout—lubricant return	63503	1351	1	Bushing—feed trip lever, upper	66503
1309	1	Gasket—spout lubricant return	66466	1352	1	Detent—on feed trip lever	63502
1310	1	Strainer—for table. (1-2 Plain, Universal and Vertical)	63789	1353	1	Bushing—feed trip lever, lower	63511
	1	Strainer—for table. (3-4 Plain, Universal and Vertical)	63849	1354	1	Lever—detent	59626
1311	1	Screw	3514	1355	1	Spring—(1-2-3-4 Universal. 3-4 Plain and Vertical)	34333
1312	1	Spring—clutch release	33744	1356	1	Spring—(1-2 Plain and Vertical)	65119
1313	1	Crank—ball	3509	1357	1	Stud—eccentric	67019
				1358	1	Bush—eccentric stud	67020
				1359	1	Bracket—under saddle. (1-2 Plain and Vertical)	67418
				1360	2	Bracket—under saddle. (1-2-3-4 Universal. 3-4 Plain and Vertical)	67419
				1361	1	Screw—dowel pin, hexagon head	68881
					1	Screw—hexagon head	63658
					1	Gear—stem bevel. (1-2-3-4 Plain and Vertical)	63668
					1	Bushing—stem bevel gear	67698
					1	Stem—locating, bracket under saddle	63667
					1	Bushing—drive shaft	63790
					2	Gear—bevel on stem bevel gear. (1-2 Plain and Vertical)	63666
					2	Gear—bevel on stem bevel gear. (1-2-3-4 Universal 3-4 Plain)	63800
					1	Bearing—bracket under saddle	63490

Continued on pages 64 and 65

SADDLE, TABLE, HOUSING PARTS — Continued

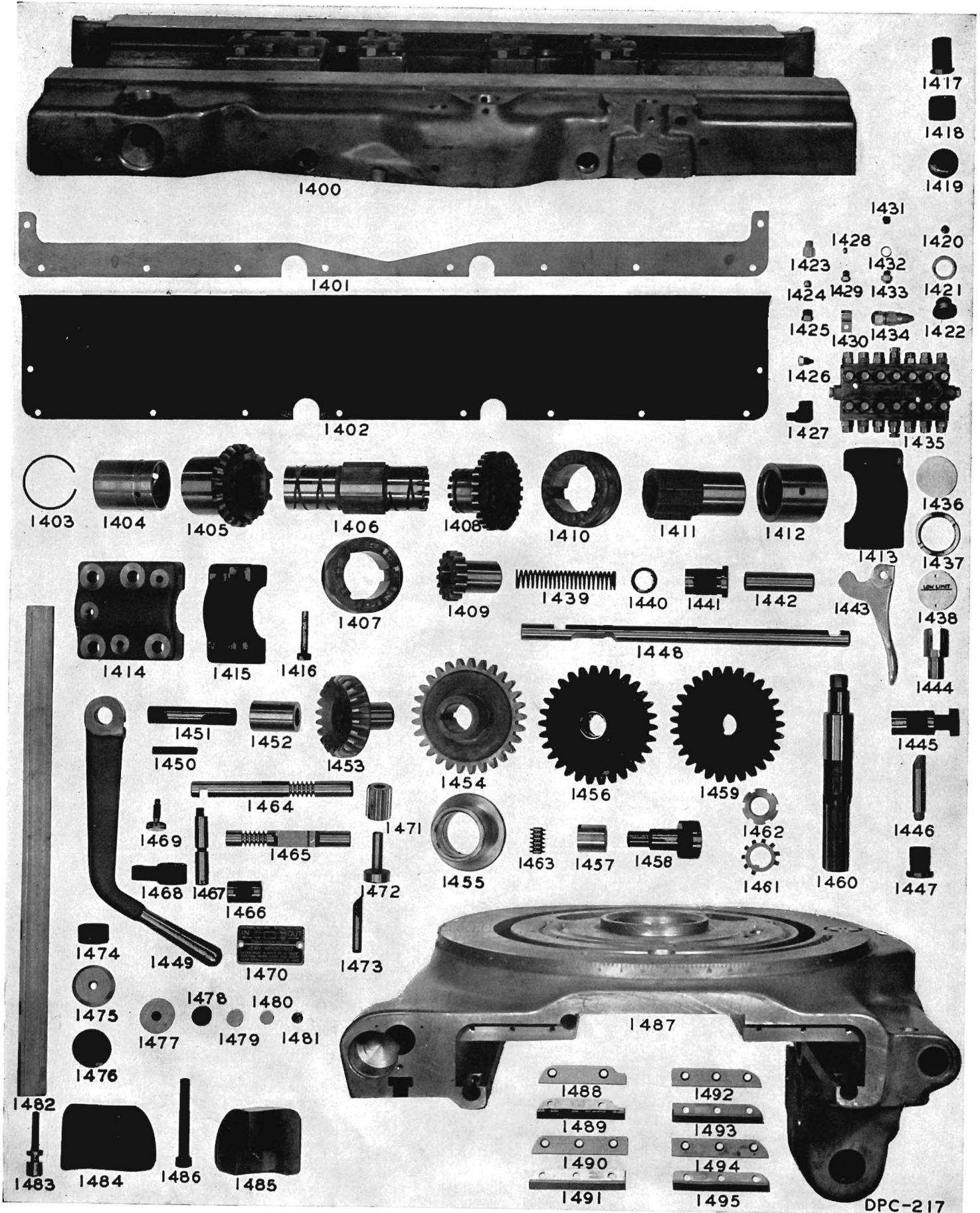

DPC-217



## SADDLE, TABLE, HOUSING PARTS LIST—Continued

Key No.	Amt. Used	PART NAME	PART NUMBER to use when ordering	Key No.	Amt. Used	PART NAME	PART NUMBER to use when ordering
1400	1	Housing. (1 Universal).....	66401	1448	1	Rod—clutch shifter. (1-2 Universal)	73837
	1	Housing. (2 Universal).....	79027		1	Rod—clutch shifter. (3 Universal)	75632
	1	Housing. (3 Universal).....	79030		1	Rod—clutch shifter. (4 Universal)	76563
	1	Housing. (4 Universal).....	79028	1449	1	Lever—clutch shifter. (1-2-3-4 Un.)	64892
1401	1	Gasket—water g'rd, housing. (1 Un.)	66459	1450	2	Pin—lock. $\frac{3}{8}$ "x2" long.....	33942
	1	Gasket—water g'rd, housing. (2 Un.)	66461	1451	1	Shaft—rear control. (1-2 Universal)	68221
	1	Gasket—water g'rd, housing. (3 Un.)	66463		1	Shaft—rear control. (3-4 Universal)	64075
	1	Gasket—water g'rd, housing. (4 Un.)	66465	1452	1	Bush—rear control shaft. (1-2-3-4 Universal).....	64074
1402	1	Guard—water, housing. (1 Univ.)..	69131	1453	1	Gear—bevel in spur gear. (1-2-3-4 Universal).....	64026
	1	Guard—water, housing. (2 Univ.)..	69132		1	Gear—stem. (1-2-3-4 Universal)...	63792
	1	Guard—water, housing. (3 Univ.)..	69133	1454	1	Bushing—stem gear. (1-2-3-4 Univ.)	63795
	1	Guard—water, housing. (4 Univ.)..	69134	1456	1	Gear—intermediate. (1-2-3-4 Univ.)	65068
1403	2	Ring—spring. (Long and short lead attachment. Universal only)....	76623	1457	1	Bushing. (1-2-3-4 Universal).....	65069
1404	2	Bushing—in bevel gear. (Long and short lead attachment. Un. only)	76622	1458	1	Stud—intermediate gear. (1-2-3-4 Universal).....	65067
1405	2	Gear—bevel on lead screw. (Long and short lead attachment. Universal only).....	76621	1459	1	Gear—drive shaft. (1-2-3-4 Univ.)	63793
1406	1	Sleeve—on lead screw. (Long and short lead attachment. Un. only)	73835	1460	1	Shaft—drive. (1-2-3-4 Universal)...	63799
1407	1	Clutch—on sleeve on lead screw...	63665	1461	1	Washer—lock. (1-2-3-4 Universal)	3807
1408	1	Gear—attachment driving. (Long and short lead attachment. Universal only).....	73836	1462	1	Nut—lock. (1-2-3-4 Universal).....	3808
1409	1	Gear—attachment driving.....	73828	1463	1	Plunger—quick traverse, back lash. (1-2-3-4 Universal).....	66527
1410	1	Clutch—lead screw sleeve. (Long and short lead attachment. Universal only).....	73827	1464	1	Rack—lead screw clutch shifter. (2 Universal).....	76748
1411	1	Sleeve—lead screw. (Long and short lead attachment. Universal only)	73826	1465	1	Rack—lead screw clutch shifter. (3 Universal).....	76746
1412	1	Bush—lead screw cap. (Long and short lead attachment. Un. only)	76775	1466	1	Rack—lead screw clutch shifter. (4 Universal).....	76747
1413	1	Cap—on lead screw. (Universal only)	73821	1465	1	Rod—lead screw clutch shifter. (1-2-3-4 Universal).....	73830
1414	1	Cap—lead screw nut.....	63510	1466	1	Bush—outer on rack. (1-2-3-4 Univ.)	76761
1415	2	Cap—on lead screw.....	63488	1467	1	Shaft—eccentric. (1-2-3-4 Universal)	76744
		Three foregoing parts are always fitted to Plain saddles and Universal housing.		1468	1	Lever—eccentric shaft. (1-2-3-4 Un.)	76745
1416	6	Pin—taper.....	83432	1469	1	Screw—change lever. (1-2-3-4 Univ.)	75393
1417	1	Screen—in oil container.....	65114	1470	1	Plate—on housing. (1-2-3-4 Universal) English.....	76647
1418	1	Nipple—oil filler.....	3912	1471	1	Pinion—shifter. (1-2-3-4 Universal)	73831
1419	1	Cap—oil filler.....	3986	1472	1	Stud—pinion shifter. (1-2-3-4 Univ.)	73832
1420	1	Ball—steel, $\frac{7}{16}$ " diameter.....	29019	1473	1	Shoe—gib clamping. (1 Un. $2\frac{3}{8}$ " long)	65132
1421	1	Gasket—screw. $\frac{3}{4}$ "x1 $\frac{1}{8}$ ".....	57148		1	Shoe—gib clamping. (1-2 Un. $2\frac{5}{8}$ " lg.)	65155
1422	1	Screw—ball valve.....	66681	1474	1	Shoe—gib clamping. (2-3 Un. $2\frac{7}{8}$ " lg.)	66436
1423	4	Adapter— $\frac{1}{8}$ " pipe to $\frac{3}{16}$ " tubing....	60719	1475	1	Shoe—gib clamping. (3-4 Un. $3\frac{1}{8}$ " lg.)	66437
1424	2	Sleeve— $\frac{5}{16}$ " tubing.....	60723	1476	1	Shoe—gib clamping. (4 Un. $3\frac{3}{8}$ " long)	66438
1425	2	Nut— $\frac{5}{16}$ " tubing.....	60724	1477	1	Nipple—in housing. (1-2-3-4 Univ.)	66994
1426	2	Plug— $\frac{3}{16}$ ", tubing connection.....	61064	1478	1	Plug—drive shaft hole. (1-2 Univ.)	63797
1427	1	Adapter— $\frac{1}{8}$ " ell for $\frac{5}{16}$ " tubing.....	60875	1476	1	Plug—pipe. (1 $\frac{1}{4}$ ". 1-2-3-4 Univ.)..	60955
1428	17	Sleeve— $\frac{1}{16}$ " tubing.....	60720	1477	1	Plug. $1\frac{1}{2}$ " diameter.....	3553
1429	17	Nut— $\frac{3}{16}$ " tubing.....	60721	1478	1	Plug. $\frac{7}{8}$ " diameter.....	3550
1430	2	Clamp.....	4002	1479	1	Plug. $\frac{3}{4}$ " diameter.....	3549
1431	2	Plug— $\frac{1}{8}$ " pipe.....	62733	1480	1	Plug. $\frac{5}{8}$ " diameter.....	3530
1432	14	Gasket—air chamber.....	60729	1481	2	Plug. $\frac{1}{2}$ " diameter. (3-4 Plain, Universal and Vertical).....	3529
1433	14	Chamber—air.....	60730	1482	1	Gib—saddle, upper. (1-2 Universal)	63602
1434	1	Check—line.....	66963		2	Gib—saddle, lower. (1-2 Universal)	63604
1435	1	Header—14 opening. (1-2-3-4 Univ.)	93298		1	Gib—saddle, upper. (3-4 Universal)	64027
1436	1	Disc—oil gage.....	3849	1483	3	Gib—saddle, lower. (3-4 Universal)	64028
1437	1	Cover—oil gage. (1-2-3-4 Universal)	63937	1484	1	Screw—gib.....	63606
1438	1	Dial—oil gage. (1-2-3-4 Universal)	60742	1485	1	Extension—L.H. Housing. (4 Univ.)	65249
1439	1	Spring—oil pump. (1-2-3-4 Univ.)..	65744	1486	2	Extension—R.H. Housing. (4 Univ.)	65248
1440	1	Packing.....	66966	1487	1	Screw.....	65250
1441	1	Gland.....	65301	1487	1	Saddle. (1-2 Universal).....	79035
1442	1	Plunger—oil shot system.....	65303		1	Saddle. (3-4 Universal).....	79034
1443	1	Lever—plunger—oil shot system. (1-2-3-4 Universal).....	65746	1488	1	Guard—wiper, front left. (1-2 Univ.)	65480
1444	1	Fulcrum—oil pump lev. (1-2-3-4 Un.)	65745		1	Guard—wiper, front left. (3-4 Univ.)	65483
1445	4	Bolt—wedge. (1-2-3-4 Universal)...	65075	1489	1	Wiper—front left. (1-2 Universal)...	70689
1446	2	Wedge—clamp, rear. (1 Universal)	63941		1	Wiper—front left. (3-4 Universal)...	70695
	2	Wedge—clamp, front. (1 Universal)	63940	1490	1	Guard, wiper, rear right. (1-2, Univ.)	68227
	2	Wedge—clamp, rear. (2 Universal)	63943		1	Guard—wiper, rear right. (3-4 Univ.)	68237
	2	Wedge—clamp, front. (2 Universal)	63939	1491	1	Wiper—rear right. (1-2 Universal)...	70691
	2	Wedge—clamp, rear. (3 Universal)	65077		1	Wiper—rear right. (3-4 Universal)...	70693
	2	Wedge—clamp, front. (3 Universal)	65078	1492	1	Guard—wiper, rear left. (1-2 Univ.)	65479
	2	Wedge—clamp, rear. (4 Universal)	63945		1	Guard—wiper, rear left. (3-4 Univ.)	65482
	2	Wedge—clamp, front. (4 Universal)	63946	1493	1	Wiper—rear left. (1-2 Universal)...	70690
1447	4	Screw—clamp. (1-2-3-4 Universal)	65076		1	Wiper—rear left. (3-4 Universal)...	70694
				1494	1	Guard—wiper, front right. (1-2 Un.)	68225
					1	Guard, wiper, front right. (3-4 Un.)	65482
				1495	1	Wiper—front right. (1-2 Universal)	70692
					1	Wiper—front right. (3-4 Universal)	70694

Continued on pages 66 and 67

SADDLE, TABLE, HOUSING PARTS — Continued

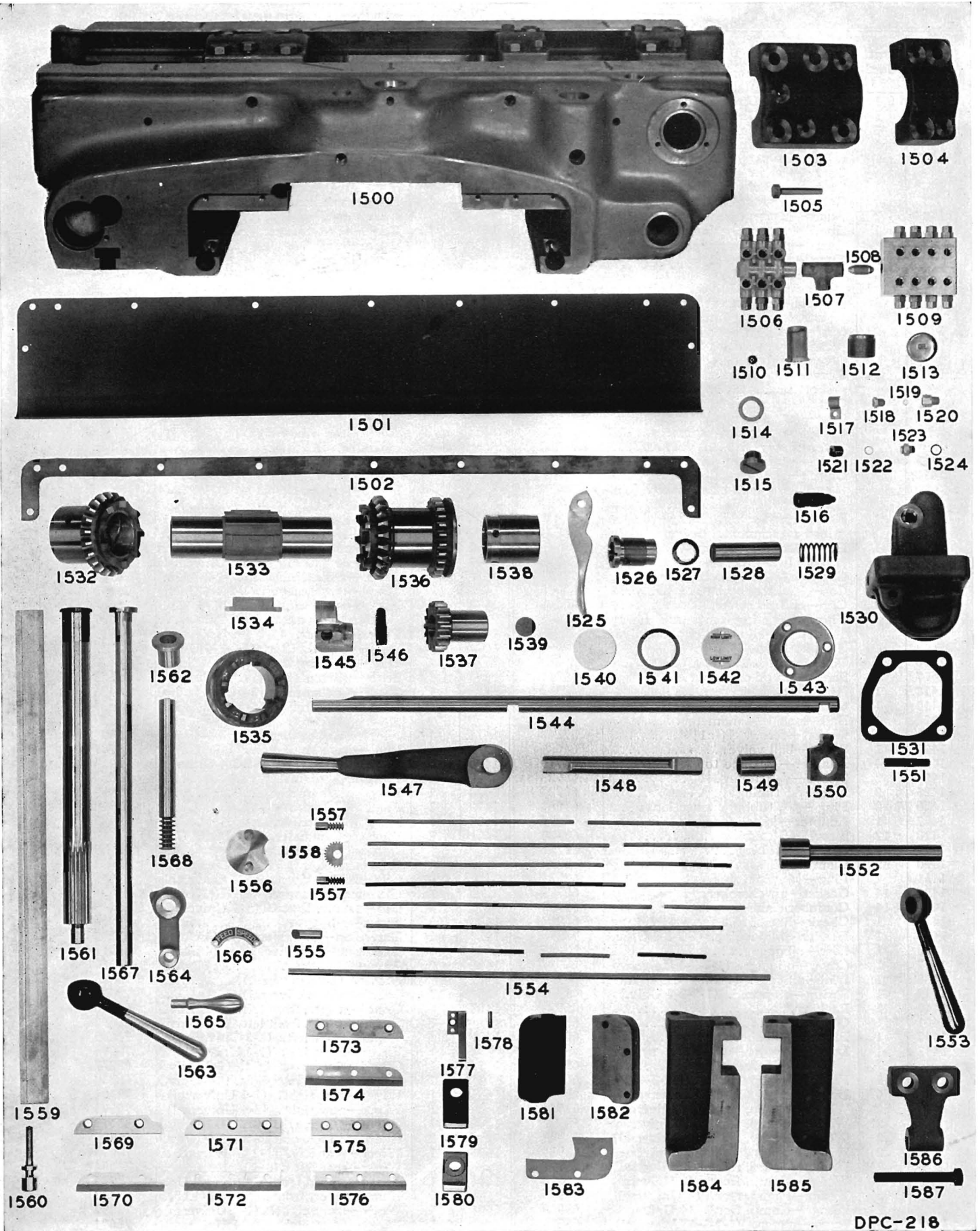

DPC-218

## SADDLE, TABLE, HOUSING PARTS LIST—Continued

Key No.	Amt. Used	PART NAME	PART NUMBER to use when ordering	Key No.	Amt. Used	PART NAME	PART NUMBER to use when ordering
1500	1	Saddle. (1 Plain and Vertical).....	79029	1553	1	Lever—clamp eccentric.....	63612
	1	Saddle. (2 Plain and Vertical).....	79031	1554	1	Tubing—oil. (1-2 Plain and Vertical)	63657
	1	Saddle. (3 Plain and Vertical).....	79033		1	Tubing—oil. (3 Plain and Vertical)	66687
	1	Saddle. (4 Plain and Vertical).....	79032		1	Tubing—oil. (4 Plain and Vertical)	68886
1501	1	Guard—water, saddle. (1 Pl. & Vt.)	77748		1	Tubing—oil. (1 Universal).....	64005
	1	Guard—water, saddle. (2 Pl. & Vt.)	69108		1	Tubing—oil. (2 Universal).....	73840
	1	Guard—water, saddle. (3 Pl. & Vt.)	69109		1	Tubing—oil. (3 Universal).....	66740
	1	Guard—water, saddle. (4 Pl. & Vt.)	69110		1	Tubing—oil. (4 Universal).....	68885
	1	Guard—water, saddle. (2 Plain and Vertical. 36" table travel).....	93145	1555	1	Shoe—gib clamping. (1 Plain and Vertical) 1 $\frac{3}{8}$ " long.....	66435
	1	Guard—water, saddle. (3 Plain and Vertical. 42" table travel).....	78484		1	Shoe—gib clamping. (1 Plain and Vertical) 1 $\frac{5}{8}$ " long.....	64954
1502	1	Gasket—water, guard. (1 Pl. & Vt.)	77749		1	Shoe—gib clamping. (2 Plain and Vertical) 1 $\frac{3}{4}$ " long.....	64938
	1	Gasket—water, guard. (2 Pl. & Vt.)	66460		1	Shoe—gib clamping. (2 Plain and Vertical) 2" long.....	64939
	1	Gasket—water, guard. (3 Pl. & Vt.)	66462		1	Shoe—gib clamping. (3 Plain and Vertical) 2 $\frac{3}{8}$ " long.....	65134
	1	Gasket—water, guard. (4 Pl. & Vt.)	66464		1	Shoe—gib clamping. (3 Plain and Vertical) 2 $\frac{5}{8}$ " long.....	65132
	1	Gasket—water, guard. (2 Plain and Vertical. 36" table travel).....	93146		1	Shoe—gib clamping. (4 Plain and Vertical) 2 $\frac{5}{8}$ " long.....	65155
	1	Gasket—water, guard. (3 Plain and Vertical. 42" table travel).....	66562		1	Shoe—gib clamping. (4 Plain and Vertical) 2 $\frac{7}{8}$ " long.....	66436
1503	1	Cap—lead screw nut.....	63510	1556	1	Bearing—stop pin. Fitted.....	67105
1504	2	Cap—on lead screw.....	63488	1557	2	Pin—stop.....	14155
1505	6	Pin—taper.....	83432	1558	1	Pinion—for stop pin.....	66670
		Three foregoing parts are always fitted to Plain Saddles.		1559	1	Gib—saddle, upper. (1 Pl. & Vt.)..	63602
1506	1	Header—6 openings. (Pl. & Vt.)...	93219		2	Gib—saddle, lower. (1 Pl. & Vt.)..	63604
1507	1	Tee— $\frac{5}{16}$ " tubing. (Pl. & Vt.).....	60727		1	Gib—saddle, upper. (2 Pl. & Vt.)..	63765
1508	2	Connection— $\frac{1}{16}$ " tubing. (Pl. & Vt.)	60726		2	Gib—saddle, lower. (2 Pl. & Vt.)..	63766
1509	1	Header—8 openings. (Pl. & Vt.)...	93297		1	Gib—saddle, upper. (3 Pl. & Vt.)..	64027
1510	1	Ball—steel. $\frac{1}{16}$ " diameter.....	29019		2	Gib—saddle, lower. (3 Pl. & Vt.)..	64028
1511	1	Screen—in oil container.....	65114		1	Gib—saddle, upper. (4 Pl. & Vt.)..	63603
1512	1	Nipple—oil filler.....	3912		2	Gib—saddle, lower. (4 Pl. & Vt.)..	63605
1513	1	Cap—oil filler.....	3986		2	Gib—saddle, lower. (4 Pl. & Vt.)..	63606
1514	1	Gasket—screw. $\frac{3}{4}$ "x1 $\frac{1}{8}$ ".....	57148	1560	3	Screw—gib.....	63606
1515	1	Screw—ball valve.....	66681	1561	2	Sleeve—quick traverse control shaft. (1 Plain and Vertical. 1-2 Univ.)	67688
1516	1	Check—line.....	66963		2	Sleeve—quick traverse control shaft. (2 Plain and Vertical).....	67692
1517	2	Clamp.....	4002		2	Sleeve—quick traverse control shaft. (3 Plain, Universal and Vertical. 4 Universal).....	67115
1518	17	Nut. $\frac{3}{16}$ " tubing.....	60721		2	Sleeve—quick traverse control shaft. (4 Plain and Vertical).....	67693
1519	17	Sleeve. $\frac{3}{16}$ " tubing.....	60720	1562	2	Sleeve—in tube quick trav. control.	63547
1520	3	Adapter. $\frac{1}{8}$ " pipe to $\frac{3}{16}$ " tubing....	60719	1563	1	Lever—control.....	3515
1521	2	Nut. $\frac{1}{16}$ " tubing.....	60724	1564	1	Lever—control, feed and speed....	67604
1522	2	Sleeve. $\frac{5}{16}$ " tubing.....	60723	1565	1	Handle.....	3501
1523	14	Chamber—air.....	60730	1566	1	Plate—speed and feed. English....	67385
1524	14	Gasket—air chamber.....	60729	1567	2	Shaft—horizontal control. (1-2 Plain, Universal and Vertical)....	69719
1525	1	Lever—plunger oil shot. (Pl. & Vt.)	65300		2	Shaft—horizontal control. (3-4 Plain, Universal and Vertical)....	69720
1526	1	Gland.....	65301	1568	1	Plunger—quick traverse.....	67106
1527	1	Packing.....	66966	1569	1	Guard—wiper, front left. (1-2 Plain and Vertical).....	65480
1528	1	Plunger—oil shot system.....	65393		1	Guard—wiper, front left. (3-4 Plain and Vertical).....	65483
1529	1	Spring—oil shot system.....	66666	1570	1	Wiper—front left. (1-2 Pl. & Vt.)..	70689
1530	1	Bracket—oil shot system. (Pl. & Vt.)	65304		1	Wiper—front left. (3-4 Pl. & Vt.)..	70695
1531	1	Gasket—oil pump br'ket. (Pl. & Vt.)	64606	1571	1	Guard—wiper, right rear. (1-2 Plain and Vertical).....	68227
1532	1	Gear—bevel, left, on lead screw. (Plain and Vertical).....	63671		1	Guard—wiper, right rear. (3-4 Plain and Vertical).....	68237
1533	1	Sleeve—on lead screw. (Pl. & Vt.)..	74124	1572	1	Wiper—right rear. (1-2 Pl. & Vt.)..	70691
1534	1	Key—in sleeve. (Pl. & Vt.).....	74123		1	Wiper—right rear. (3-4 Pl. & Vt.)..	70693
1535	1	Clutch—on sleeve on leadscrew....	63665	1573	1	Guard—wiper, front right. (1-2 Plain and Vertical).....	68225
1536	1	Gear—bevel, right, on lead screw. (Plain and Vertical).....	63670		2	Guard—wiper, front right, rear left. (3-4 Plain and Vertical).....	65482
1537	1	Gear—attachment driving.....	73828	1574	1	Wiper—front right. (1-2 Pl. & Vt.)	70692
1538	2	Bushing—in lead screw bevel gear. (Plain and Vertical).....	63680		2	Wiper—front right, rear left. (3-4 Plain and Vertical).....	70694
1539	1	Plug. $\frac{7}{8}$ " diameter.....	3550	1575	1	Guard—wiper, rear left. (1-2 Plain and Vertical).....	65479
1540	1	Disc—oil gauge.....	3849	1576	1	Wiper—rear left. (1-2 Pl. & Vt.)..	70690
1541	3	Gasket—oil gauge.....	3850				
1542	1	Dial—oil gauge. (Pl. & Vt.).....	60956				
1543	1	Cover—oil gauge. (Pl. & Vt.).....	3848				
1544	1	Rod—rear feed control. (Pl. & Vt.)	63504				
1545	1	Fork—clutch.....	63489				
1546	1	Pin—lock. $\frac{1}{2}$ "x1 $\frac{5}{8}$ ".....	38368				
1547	1	Lever—clutch shifter. (Pl. & Vt.)..	63515				
1548	1	Stud—lever feed control. (Pl. & Vt.)	63506				
1549	1	Bushing.....	3832				
1550	1	Lever—rear table feed.....	63507				
1551	2	Pin—lock. $\frac{3}{8}$ "x2" long.....	33942				
1552	1	Clamp—eccentric. (1-2 Pl., Un. & Vt.)	78968				
	1	Clamp—eccentric. (3-4 Pl., Un. & Vt.)	78969				

Continued on page 69



# TABLE HAND FEED ATTACHMENT PARTS

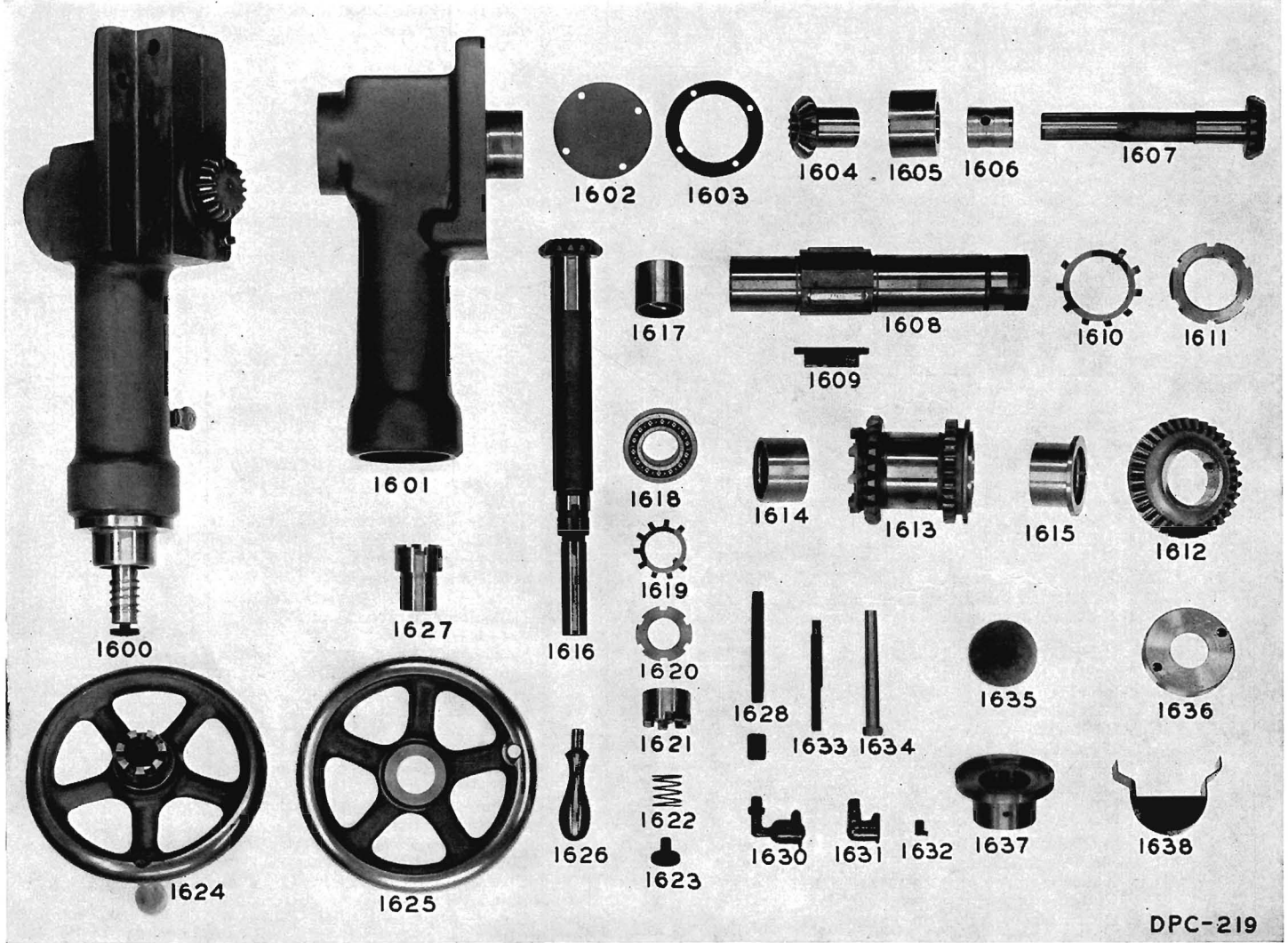

DPC-219

SADDLE, TABLE, HOUSING PARTS LIST—Concluded

Key No.	Amt. Used	PART NAME	PART NUMBER to use when ordering	Key No.	Amt. Used	PART NAME	PART NUMBER to use when ordering
1577	2	Dog—positive stop, cross feed. ....	77858	1584	1	Extension—water trough saddle. R. H. (1-2-3 Plain and Vertical. 32"-36"-42" table travel).....	66559
	1	Dog—positive stop, cross feed. (2-3-4 Vertical) .....	95006	1585	1	Extension—water trough saddle. L. H. (1-2-3 Plain and Vertical. 32"-36"-42" table travel).....	66558
	1	Dog—positive stop, cross feed. (3-4 Universal).....	95005	1586	1	Stop—hand, left. (1-2 Plain, Universal and Vertical).....	67978
1578	4	Pin.....	3541		1	Stop—hand, right. (1-2 Plain, Universal and Vertical).....	67979
1579	1	Dog—large cross feed.....	63693		2	Stop—hand, R. and L. (3-4 Plain, Universal and Vertical).....	67980
1580	1	Dog—small cross feed.....	63694	1587	2	Bolt—hand stop. (1-2-3-4 Plain, Universal and Vertical).....	67726
1581	1	Extension—saddle. R.H. (1 Plain and Vertical).....	77744				
1582	1	Extension—saddle. L.H. (1 Plain and Vertical).....	77745				
1583	2	Gasket—under extension saddle. (1 Plain and Vertical).....	77743				

TABLE HAND FEED ATTACHMENT PARTS LIST

Key No.	Amt. Used	PART NAME	PART NUMBER to use when ordering	Key No.	Amt. Used	PART NAME	PART NUMBER to use when ordering
1600	1	Bracket—table hand feed. (1-2 Plain and Vertical).....	73789RF	1624	1	Hand—wheel. 8". Fitted.....	3511F
	1	Bracket—table hand feed. (3-4 Plain and Vertical).....	65804RF	1625	1	Hand-wheel. 8".....	3511
		Two brackets above are fitted complete.		1626	1	Handle.....	3502
1601	1	Bracket—table hand feed. (1-2 Plain and Vertical) Not fitted....	73789	1627	1	Clutch—for hand-wheel.....	3506
	1	Bracket—table hand feed. (3-4 Plain and Vertical) Not fitted....	65804	1628	1	Pipe. 1/8"x2 3/4". (4 Plain and Vertical).....	67383
1602	1	Cover.....	65794	1629	1	Coupling. 1/8" pipe. (4 Plain and Vertical).....	21494
1603	1	Gasket—cover.....	65793	1630	1	Oiler. 1/8" pipe. Lunkenheimer No. 971. Size No. 1. (3-4 Plain and Vertical).....	65810
1604	1	Gear—bevel on vertical stem gear.....	65799	1631	1	Oiler. 1/8" pipe, spring top. Gits, style KV No. 620.....	44979
1605	1	Bush—bevel gear.....	65791	1632	1	Oiler. 3/8" diameter, spring top. Gits No. 502. (1-2 Plain and Vertical).....	44980
1606	1	Bush—on vertical stem gear.....	65792	1633	1	Pin—table stop. (1-2 Plain and Vertical).....	73793
1607	1	Pinion—stem bevel gear.....	65801	1634	1	Pin—taper, hexagon head.....	39616
1608	1	Sleeve—on lead screw.....	65802	1635	1	Plug. 2 1/4" diameter.....	3556
1609	1	Key—in sleeve on lead screw.....	74123	1636	1	Nut—ball bearing adjustment.....	65789
1610	1	Washer—lock. 1 7/8" hole.....	3795	1637	1	Guard—clutch.....	65796
1611	1	Nut—lock. 1 7/8" hole.....	3796	1638	1	Guard—bevel gear.....	75131
1612	1	Gear—bevel on sleeve on lead screw.....	65790			NOTE: Saddle, all sizes, must be altered to apply this attachment.	
1613	1	Gear—bevel, R.H. feed.....	65803			1-2 Machines.	
1614	2	Bushing—bevel gear.....	65797			Rear table apron and bracket oil shot system must be altered to apply this attachment on these sizes of machines.	
1615	1	Bush—bevel gear flanged.....	75166				
1616	1	Gear—stem.....	65800				
1617	1	Bushing—stem gear.....	65795				
1618	1	Bearing—ball. S.K.F. No. 2206.....	65813				
1619	1	Washer—lock. 1 1/8" hole.....	3809				
1620	1	Nut—lock. 1 1/8" hole.....	3810				
1621	1	Clutch.....	65798				
1622	1	Spring.....	33744				
1623	1	Screw.....	3514				



# HAND FEED WORM BOX PARTS

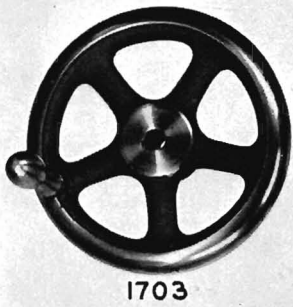

1703



1702

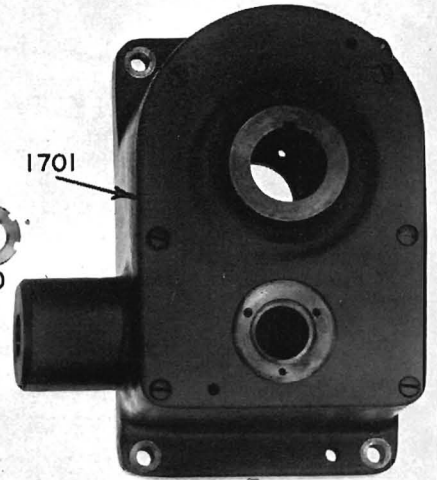

1701

1700



1705



1706



1707



1708



1709



1710



1704



1712



1713



1714



1711



1721

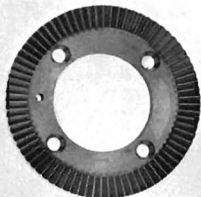

1718



1717

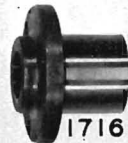

1716



1715



1725



1720



1723



1724



1719



1722



1746



1732



1726



1727



1752



1754



1755



1741



1742



1744



1743



1745



1728



1729



1751



1753



1740



1730



1747



1748



1749



1750

DPC-220

HAND FEED WORM BOX PARTS LIST

Key No.	Amt. Used	PART NAME	PART NUMBER to use when ordering	Key No.	Amt. Used	PART NAME	PART NUMBER to use when ordering
1700	1	Box—worm. Fitted with cover . . . .	63758	1726	1	Cover—oil gauge . . . . .	3848
1701	1	Cover—worm box . . . . .	63776	1727	3	Gasket—oil gauge . . . . .	3850
1702	1	Shaft—worm . . . . .	69512	1728	1	Dial—oil gauge . . . . .	70641
1703	1	Wheel—hand. 8" Fitted with handle	3510F	1729	1	Disc—oil gauge . . . . .	3849
1704	1	Handle . . . . .	3502	1730	1	Bracket—on head . . . . .	63774
1705	1	Bearing—ball thrust. S.K.F. No. 906	54028	1731	1	Dial—adjusting head. English . . . . .	37430
1706	1	Worm . . . . .	71251	1731	1	Dial—adjusting head. Metric . . . . .	78720
1707	1	Bearing—ball thrust. S.K.F. No. 2907 . . . . .	89008	1732	1	Screw . . . . .	37427
1708	1	Bushing—worm shaft . . . . .	3603			<b>Turret Stop Attachment</b>	
1709	1	Washer—lock . . . . .	3809	1740	1	Housing—indicator . . . . .	70308
1710	1	Nut—lock, worm shaft . . . . .	69563	1741	1	Plunger . . . . .	79294
1711	1	Retainer—oil . . . . .	63629	1742	1	Cover—plunger . . . . .	70316
1712	1	Dial—on worm shaft. English . . . . .	71258	1743	1	Pin—in plunger . . . . .	70315
	1	Dial—on worm shaft. Metric . . . . .	78729	1744	1	Lever—indicator operating . . . . .	70317
1713	1	Pipe—oil drain . . . . .	67432	1745	1	Pin—lever . . . . .	70318
1714	1	Plug— $1\frac{3}{8}$ " diameter . . . . .	62581	1746	1	Dial—indicator. English . . . . .	73975
1715	1	Pinion—rack . . . . .	77875	1746	1	Dial—indicator. Metric . . . . .	75249
1716	1	Bushing—shaft worm wheel . . . . .	63549	1747	1	Housing—turret . . . . .	70309
1717	1	Wheel—worm . . . . .	77872		1	Housing—turret. Fitted complete . . . . .	70309RF
1718	1	Clutch—on worm wheel . . . . .	33942	1748	1	Turret . . . . .	70311
1719	1	Collar—on rack pinion shaft . . . . .	77869	1749	1	Ball— $\frac{3}{8}$ " diameter . . . . .	30154
1720	1	Sleeve—for clutch . . . . .	12184	1750	1	Spring . . . . .	3942
1721	1	Clutch—on sleeve . . . . .	33491	1751	1	Housing—stop . . . . .	70312
1722	1	Knob—on clutch sleeve . . . . .	12123	1752	2	Spring . . . . .	70321
1723	1	Hub—pilot wheel . . . . .	13008	1753	4	Screw—adjusting stop . . . . .	70313
	1	Hub—pilot wheel. Fitted with 4 spokes . . . . .	13008F	1754	4	Nut—lock, adjusting screw . . . . .	70320
1724	4	Spoke—pilot wheel . . . . .	13007	1755	4	Spacer . . . . .	70319
1725	1	Tube—telescopic. (Small) . . . . .	63340				

POWER FEED WORM BOX PARTS

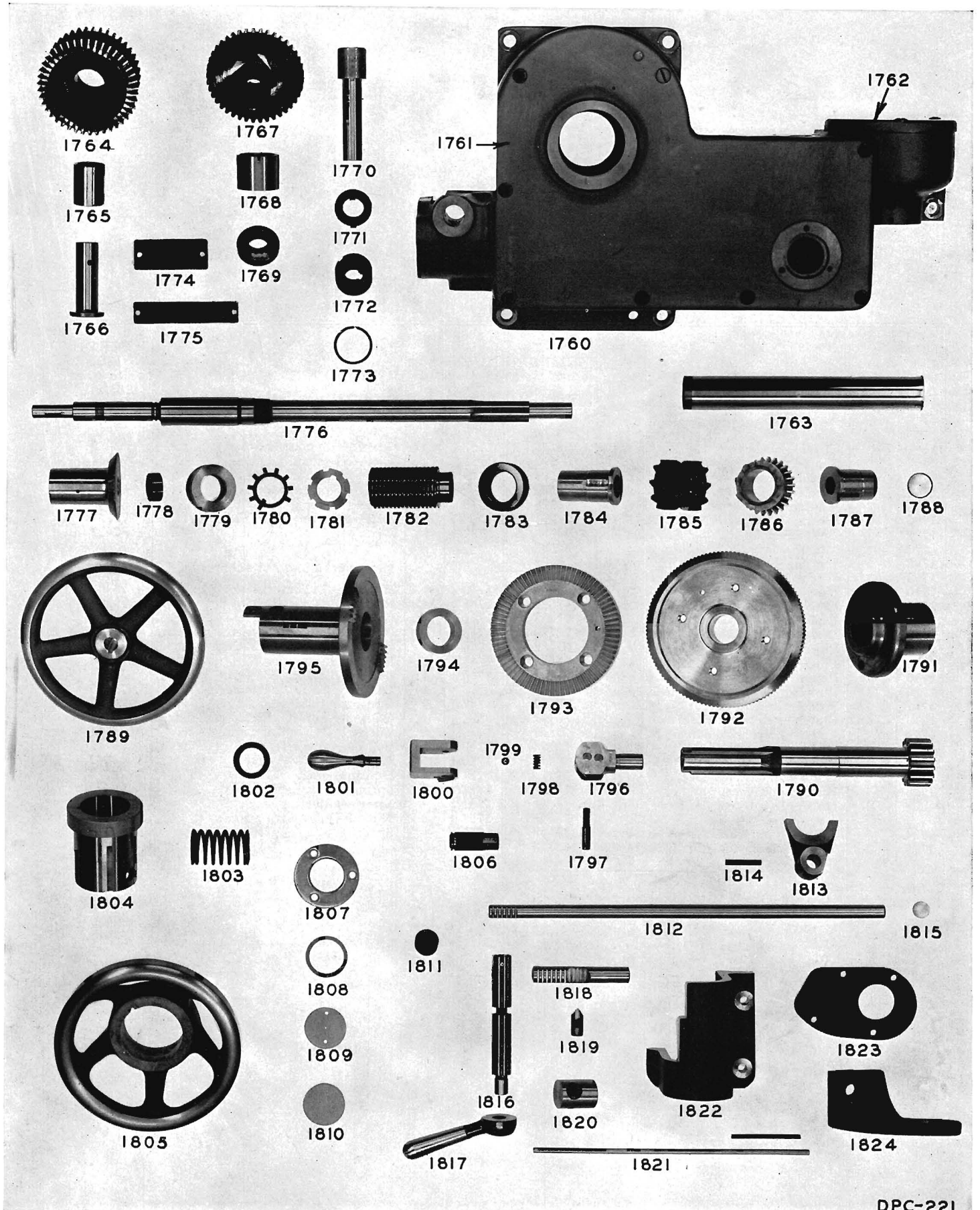

DPC-221

POWER FEED WORM BOX PARTS LIST

Key No.	Amt. Used	PART NAME	PART NUMBER to use when ordering	Key No.	Amt. Used	PART NAME	PART NUMBER to use when ordering
1760	1	Box—Worm—fitted with two covers. (1-2 Vertical)	78084	1786	2	Gear—mitre clutch	71929
	1	Box—Worm—fitted with two covers. (3-4 Vertical)	78106	1787	1	Bush—small, on worm shaft	71925
	1	Box—Worm—fitted complete. (1-2 Vertical)	78084RF	1788	1	Plug—1" diameter, expansion	203828
	1	Box—Worm—fitted complete. (3-4 Vertical)	78106RF	1789	1	Wheel—hand. 8"	78062
1761	1	Cover—front, worm box. (1-2 Vertical)	69776	1790	1	Shaft—worm wheel	77874
	1	Cover—front, worm box. (3-4 Vertical)	69756	1791	1	Bush—shaft worm wheel	63549
1762	1	Cover—drive shaft	63372	1792	1	Wheel—worm	77872
1763	1	Tube—telescopic, small	63340	1793	1	Clutch—on worm wheel	33492
1764	1	Gear—driven reverse	71928	1794	1	Collar—worm wheel shaft	77869
1765	1	Bush	3597	1795	1	Clutch—sliding	77873
1766	1	Stud—reverse mitre gear	63382	1796	1	Stud—for eccentric	78794
1767	1	Gear—drive	71927	1797	1	Screw— $\frac{3}{8}$ "x1 $\frac{1}{8}$ "	76554
1768	1	Bush—drive gear	63367	1798	1	Spring—compression	63389
1769	1	Retainer—oil, drive shaft	69626	1799	1	Ball—steel. $\frac{3}{8}$ " diameter	30154
1770	1	Shaft—drive	63365	1800	1	Eccentric—sliding clutch	76552
1771	1	Coupling—intermediate, drive shaft	69830	1801	6	Handle—tight	3501
1772	2	Coupling—drive shaft	69460	1802	1	Washer	77871
1773	2	Spring—ring	63370	1803	1	Spring—clutch release	77870
1774	1	Plate—head feed. English. (High Speed Machines) $\frac{1}{4}$ to 0.6 feed rate	78124	1804	1	Bush—in worm box cover	63933
	1	Plate—head feed. English. (Medium Speed Machines) $\frac{1}{8}$ to 0.5 feed rate	78136	1805	1	Wheel—hand, 8" dished	63390
1775	1	Plate—Caution head feed. English	69631	1806	1	Pipe—oil drain	67432
1776	1	Shaft—worm. (1-2 Vertical)	71931	1807	1	Cover—oil gauge	3848
	1	Shaft—worm. (3-4 Vertical)	78103	1808	3	Gasket—oil gauge	3850
1777	1	Dial—on worm shaft. English	71258	1809	1	Dial—oil gauge	70641
	1	Dial—on worm shaft. Metric	78729	1810	1	Disc—oil gauge	3849
1778	1	Retainer—oil	63629	1811	1	Plug—pipe. $\frac{3}{4}$ " diameter	57726
1779	1	Bearing—ball thrust. S.K.F. No. 906	54028	1812	1	Rack—fork shifter. (1-2 Vertical)	63384
1780	1	Washer—lock. 1 $\frac{1}{8}$ " diameter	3809	1813	1	Rack—fork shifter. (3-4 Vertical)	63726
1781	1	Nut—lock 1 $\frac{1}{8}$ " diameter	69563	1814	1	Fork—reverse shifter	71926
1782	1	Worm	71251	1815	2	Pin—in fork	66444
1783	1	Bearing—ball thrust. S.K.F. No. 2907	89008	1816	1	Plug— $\frac{3}{4}$ " expansion	81429
1784	1	Bush—large, on worm shaft	71924	1817	1	Pinion—trip lever	63386
1785	1	Clutch—reverse	69462	1818	1	Lever	3516
				1819	1	Rack—feed trip	69459
				1820	1	Plunger—head feed trip	53144
				1821	1	Distributor—oil	67433
				1822	1	Tubing—oil. (1-2 Vertical)	67439
					1	Tubing—oil. (3-4 Vertical)	67438
					1	Cover—lower drive shaft. (1-2 Vertical)	63373
					1	Cover—lower drive shaft. (3-4 Vertical)	63551
				1823	1	Cover—on feed box	70878
				1824	2	Dog—stop	63391



# BELT DRIVE AND MOTOR DRIVE PARTS

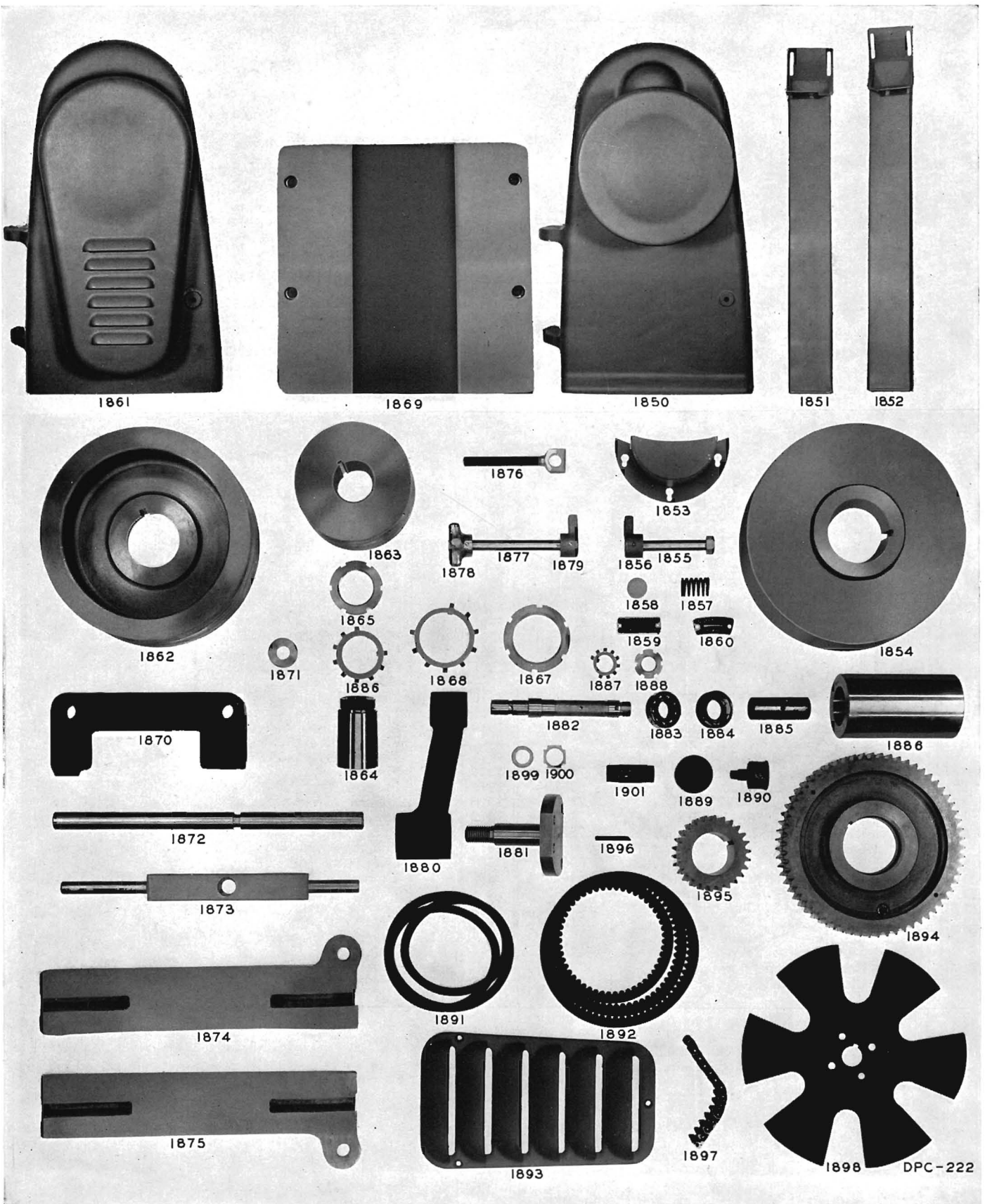

DPC-222



BELT DRIVE AND MOTOR DRIVE PARTS LIST

Key No.	Amt. Used	PART NAME	PART NUMBER to use when ordering	Key No.	Amt. Used	PART NAME	PART NUMBER to use when ordering
1850	1	Cover—belt drive. (1-2-3-4 Plain and Universal. 1-2 Vertical).....	63569	1873	1	Bracket—for eye bolt. (3-4 Mach.)	73563
	1	Cover—belt drive. (3-4 Vertical)...	63576	1874	1	Rail—motor, rear. (1-2 Plain, Universal and Vertical. 1800 R.P.M. 3 Vt. 1500 R.P.M. 4 Vt. 1800 R.P.M. motors) 1 1/4" thick.....	70497
1851	1	Guard—belt. L.H.....	63568		1	Rail—motor, rear. (3 Vertical. 1800 R.P.M. motor) 1 1/4" thick.....	69498
1852	1	Guard—belt. R.H.....	63567		1	Rail—motor, rear. (1-2 Plain, Universal and Vertical. 1200-1500 R.P.M. 4 Vertical. 1500 R.P.M. 3 Plain and Universal. 1200-1500-1800 R.P.M. 4 Plain and Universal. 1200 R.P.M. motors) 1 1/4" thick.....	69640
1853	1	Cover—coolant pump gear.....	78674		1	Rail—motor, rear. (3-4 Vertical. 1200 R.P.M. 4 Plain and Universal. 1500-1800 R.P.M. motors) 1" thick.....	73551
1854	1	Pulley—driven.....	63566		1	Rail—motor, front. (1-2 Plain, Universal and Vertical. 1800 R.P.M. 3 Vt. 1500 R.P.M. 4 Vt. 1800 R.P.M. motors) 1 3/4" thick.....	70496
1855	1	Stud—cover latch. Fitted with latch	63565F		1	Rail—motor, front. (3 Vertical. 1800 R.P.M. motor) 1 1/4" thick.....	69497
	1	Stud—cover latch.....	63565		1	Rail—motor, front. (1-2 Plain, Universal and Vertical. 1200-1500 R.P.M. 4 Vertical. 1500 R.P.M. 3 Plain and Universal. 1200-1500-1800 R.P.M. 4 Plain and Univ. 1200 R.P.M. motors) 1 1/4" thick..	69639
1856	1	Latch—cover.....	3919		1	Rail—motor, front. (3-4 Vertical. 1200 R.P.M. 4 Vertical. 1500-1800 R.P.M. motors) 1" thick....	73550
1857	1	Spring.....	3922		2	Bolt—eye.....	73564
1858	1	Plug. 1 1/8" diameter.....	3830	1876	2	Stud—motor cover latch. (Fitted with knob and latch).....	62801F
1859	1	Plate—cover removal.....	78675	1877	1	Stud—motor cover latch.....	62801
1860	1	Plate—pulley direction. English...	3889		1	Knob.....	3920
		<b>Motor Drive Parts</b>			1	Latch.....	3919
					1	Spring.....	3922
1861	1	Cover—motor drive. (1-2 Plain, Universal and Vertical).....	62872	1880	1	Bracket—idler. (4 Horizontal. 15 H.P. D.C. motor).....	94461
	1	Cover—motor drive. (3-4 Horizontal 10 and 15 H.P. motors).....	75262		1	Stud—idler. (4 Horizontal. 15 H.P. D.C. motor).....	94460
	1	Cover—motor drive. (3-4 Vertical)	63577	1881	1	Shaft—idler pulley. (4 Horizontal. 15 H.P. D.C. motor).....	94459
1862	1	Sheave—driven. (1-2 Plain, Universal and Vertical).....	74278	1882	1	Bearing—New Departure No. 3205	90981
	1	Sheave—driven. (3 Plain, Universal and Vertical. 10 H.P. 1200-1500 R.P.M. motors. 4 Horizontal 10 H.P. 1200-1500-1800 R.P.M. motors. 4 Vt. 1200 R.P.M. motor)	73568	1883	1	Plug—in idler pulley. (4 Horizontal. 15 H.P. D.C. motor).....	94458
	1	Sheave—driven. (3 Vertical 1800 R.P.M. motor. 4 Vertical 1500-1800 R.P.M. motors).....	73438	1884	1	Spacer—idler pulley. (4 Horizontal. 15 H.P. D.C. motor).....	75255
	1	Sheave—driven. (4 Horizontal 15 H.P. 1200-1500-1800 R.P.M. motors).....	75261	1885	1	Pulley—idler. (4 Horizontal. 15 H.P. D.C. motor).....	75259
	1	Sheave—driven. (4 Vertical 1500-1800 R.P.M. 15 H.P. motors)...	78091	1887	1	Washer—lock. 7/8" diameter.....	3807
1863	1	Sheave—motor. (1-2 Horizontal and Vertical 1200 R.P.M. motor).....	93001	1888	1	Nut—lock. 7/8" diameter.....	3808
	1	Sheave—motor. (1-2 Horizontal and Vertical. 1500 R.P.M. motor)...	93002	1889	1	Plug. 2 1/8" diameter.....	3852
	1	Sheave—motor. (1-2 Horizontal and Vertical. 1800 R.P.M. motor)...	93003	1890	1	Cup—grease.....	83318
	1	Sheave—motor. (3-4 Horizontal. 1800 R.P.M. motor).....	93005	1891	4	Belt—Vulco rope. (1-2 Pl. & Univ.)	78542
	1	Sheave—motor. (3-4 Vertical. 1800 R.P.M. motor).....	93006		4	Belt—Vulco rope. (1-2 Vertical)...	78736
	1	Sheave—motor. (4 Vertical. 1500 R.P.M. motor).....	93007		5	Belt—Vulco rope. (3-4 Plain and Vertical. 1200-1500-1800 R.P.M. 4 Vt. 1500-1800 R.P.M. motors)	78542
	1	Sheave—motor. (3-4 Vertical. 1200 R.P.M. motor).....	93009		5	Belt—Vulco rope. (1-2 Horizontal. 7 1/2 H.P. motor).....	78825
	1	Sheave—motor. (3-4 Horizontal and 3 Vertical. 1500 R.P.M. motor)...	93010	1892	5	Belt—cog. (3 Vertical. 1800 R.P.M. 4 Vt. 1500-1800 R.P.M. motors)	78824
	1	Sheave—motor. (4 Vertical. 1500 R.P.M. 15 H.P. motor).....	93012		5	Belt—cog. (3 Vertical. 1200-1500 R.P.M. 4 Vt. 1200 R.P.M. motor)	73573
	1	Sheave—motor. (4 Vertical. 1800 R.P.M. 15 H.P. motor).....	93014	1893	8	Belt—cog.....	75258
	1	Sheave—motor. (4 Horizontal. 15 H.P. 1800 R.P.M. motor).....	93015		1	Louvre. (4 Vertical. 15 H.P. A.C. and D.C. motors).....	3787
1864	1	Sleeve—motor, blank.....	93004	1894	1	Gear—chain, driven.....	70609
	1	Sleeve—motor, blank. (3-4 Plain, Universal and Vertical).....	93008	1895	1	Pinion—chain, blank. 26T.....	93018
	1	Sleeve—motor, blank. (3-4 Horizontal and Vertical).....	93011		1	Pinion—chain, blank. 21T.....	93017
	1	Sleeve—motor, blank. (4 Plain and Un. 15 H.P. 1500 R.P.M. motor)	93013		1	Pinion—chain, blank. 33T.....	93019
	1	Sleeve—motor, blank. (4 Plain, Universal and Vt. 15 H.P. motor)...	93016	1896	1	Tube—oil.....	69557
1865	1	Nut—lock. 2" diameter.....	3813	1897	1	Chain—motor.....	70607
1866	1	Washer—lock. 2" diameter.....	3643	1898	1	Fan—motor sheave, blank.....	74526
1867	1	Nut—lock. 2 3/4" diameter.....	3798		1	Clutch—starting lever.....	70186
1868	1	Washer—lock. 2 3/4" diameter.....	3797				
1869	1	Plate—motor.....	66845				
1870	1	Bracket—motor rail. (1-2 Mach.)...	73556				
	1	Bracket—motor rail. (3-4 Mach.)...	73437				
1871	2	Washer—under motor rail bracket. (1-2 Vertical).....	67328				
	2	Washer—under motor rail bracket. (1-2 Vertical).....	64593				
1872	1	Shaft—motor rail.....	75408				
1873	1	Bracket—for eye bolt. (1-2 Mach.)	73562				

NOS. 3 AND 5 PLAIN AND SWIVEL VISE PARTS

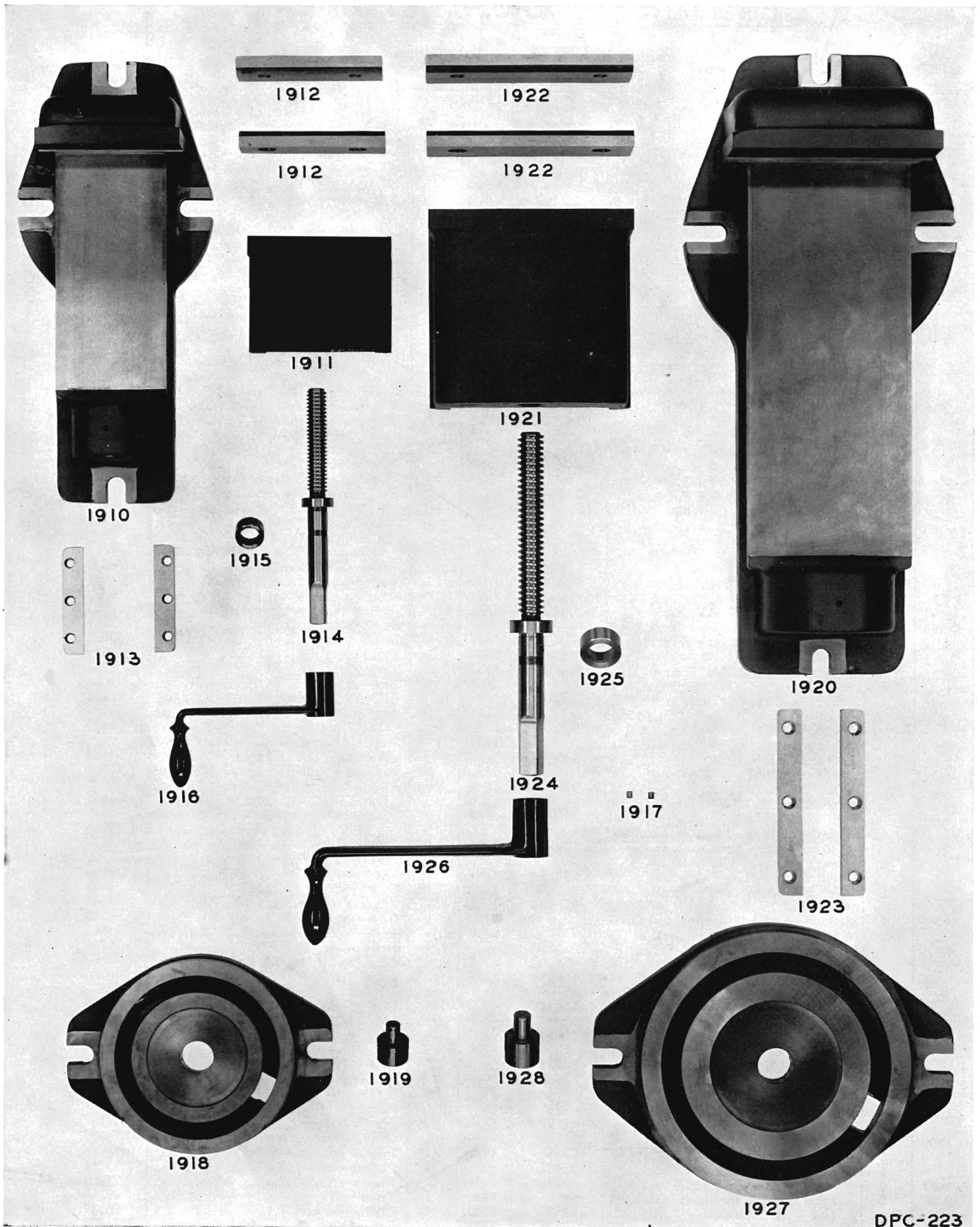

DPC-223

NOS. 3 AND 5 PLAIN AND SWIVEL VISE PARTS LIST

Key No.	Amt. Used	PART NAME	PART NUMBER to use when ordering	Key No.	Amt. Used	PART NAME	PART NUMBER to use when ordering
<b>No. 3 Plain and Swivel Vise</b>				<b>No. 5 Plain and Swivel Vise</b>			
1910	1	Body—vise . . . . .	66663	1920	1	Body—vise . . . . .	63022
	1	Body—vise. (Fitted complete) . . . . .	66663F		1	Body—vise. (Fitted complete) . . . . .	63022F
1911	1	Housing . . . . .	66662	1921	1	Housing . . . . .	63020
1912	2	Jaw—vise . . . . .	118956	1922	2	Jaw—vise . . . . .	63018
1913	2	Gib—housing . . . . .	63023	1923	2	Gib—housing . . . . .	63019
1914	1	Screw . . . . .	63026	1924	1	Screw . . . . .	63021
1915	1	Collar—on screw . . . . .	22331	1925	1	Collar—on screw . . . . .	22332
1916	1	Crank—hand . . . . .	3565	1926	1	Crank—hand . . . . .	3566
1917	2	Cup—oil . . . . .	60062	1917	2	Cup—oil . . . . .	60062
1918	1	Plate—swivel. (No 3 Swivel Vise) . . . . .	60537	1927	1	Plate—swivel. (No. 5 Swivel Vise) . . . . .	60539
1919	1	Stud—in swivel plate. (No. 3 Swivel Vise) . . . . .	10624	1928	1	Stud—in swivel plate. (No. 5 Swivel Vise) . . . . .	10539

# DIVIDING HEAD PARTS

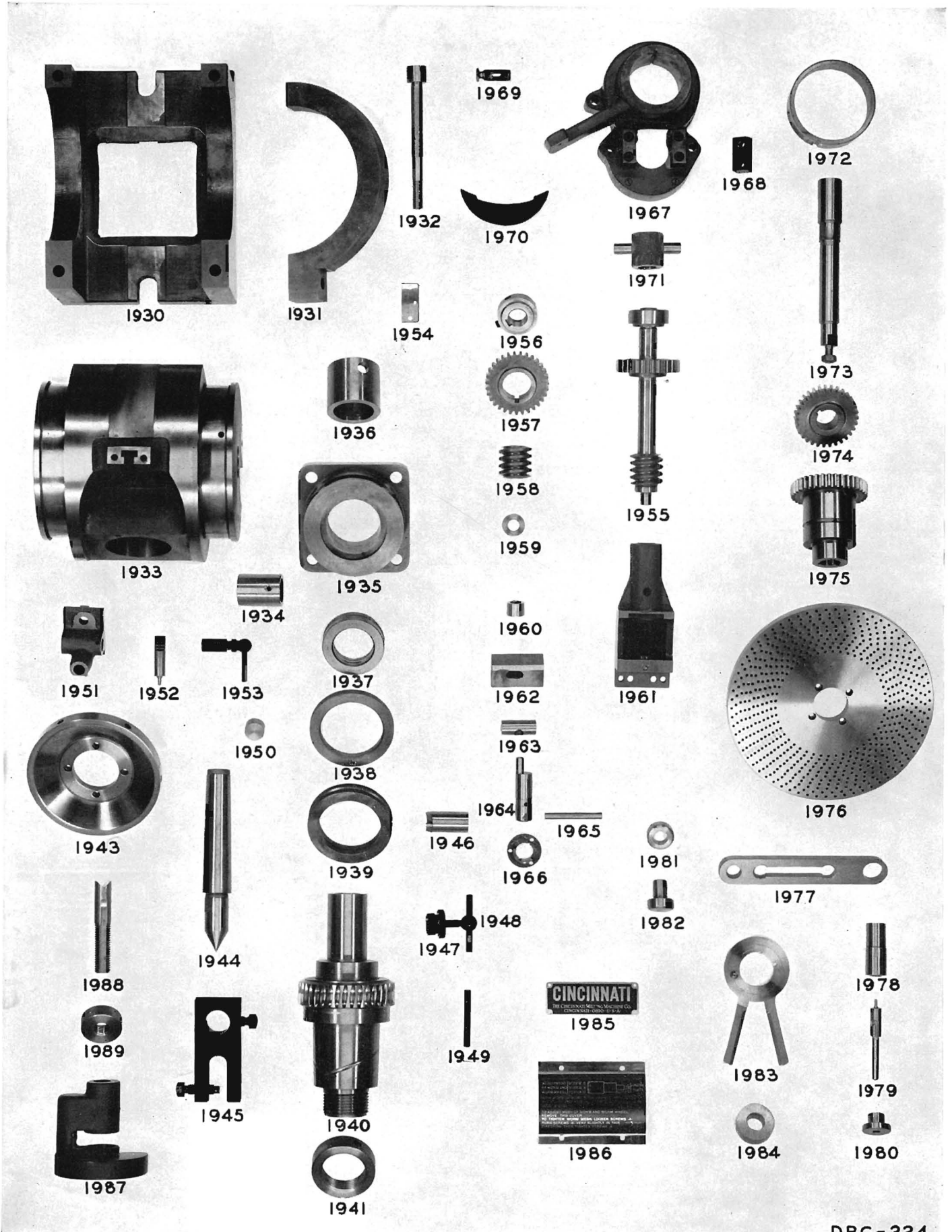

DPC-224



## DIVIDING HEAD PARTS LIST

Key No.	Amt. Used	PART NAME	PART NUMBER to use when ordering		
			10" Head	12" Head	14" Head
1930	1	Housing.....	*60515	*60517	*60519
1931	2	Clamp.....	* 8354	* 8412	* 8412
1932	2	Screw—clamp.....	45793	45794	45795
1933	1	Block—swivel.....	* 5556	* 8213	* 8213
1934	1	Bush—in swivel block.....	23596	23596	23596
1935	1	Cap—back of spindle.....	76954	76959	76959
1936	1	Bush—cap back of spindle.....	76952	76957	76957
1937	1	Bearing—thrust.....	102145	102144	102144
1938	1	Collar—on spindle.....	76953	76958	76958
1939	1	Ring—split.....	8369	8424	8424
1940	1	Spindle. Fitted with worm wheel.....	*76945RF	*76944RF	*76944RF
	1	Spindle.....	*76945	*76944	*76944
1941	1	Cover—over spindle thread.....	33592	33593	33593
1942	1	Wheel—worm.....	35155	35156	35156
1943	1	Plate—front.....	8365	8421	8421
1944	1	Center.....	107830	107829	107829
	1	Center—for compensating dog.....	107834	108991	108991
1945	1	Holder—for dog.....	24102	24102	24102
1946	1	Plug—split ring.....	8366	8422	8422
1947	1	Cap—hand clamp.....	8225	8225	8225
1948	1	Screw—hand clamp.....	3536	3536	3536
1949	1	Handle—hand clamp screw.....	3537	3537	3537
1950	1	Plug—swivel block. 1/8" diameter.....	8367	8367	8367
1951	1	Holder—pin index. Fitted complete.....	8234F	8234F	8234F
	1	Holder—pin index.....	8234	8234	8234
1952	1	Pin—index.....	8363	8363	8363
1953	1	Pinion.....	19084	19084	19084
1954	1	Vernier.....	8231	8233	8233
1955	1	Shaft—worm. Fitted complete.....	*35130RF	*35131RF	*35131RF
1955	1	Shaft—worm.....	*35130	*35131	*35131
1956	1	Nut—lock.....	35125	35126	35126
1957	1	Gear—on worm shaft.....	103490	103493	103493
1958	1	Worm.....	34391	34393	34393
1959	1	Nut.....	8361	8419	8419
1960	1	Bush—in yoke.....	8352	8410	8410
1961	1	Yoke. Fitted complete.....	5774F	5775F	5775F
	1	Yoke.....	5774	5775	5775
1962	1	Holder—slide.....	8223	8222	8222
1963	1	Slide.....	8373	8428	8428
1964	1	Eccentric. Fitted complete.....	8296F	8297F	8297F
	1	Eccentric.....	8296	8297	8297
1965	1	Handle—for eccentric.....	1263	1263	1263
1966	1	Plate—eccentric stop.....	8295	8294	8294
1967	1	Cover—on swivel block. Fitted complete.....	8356RF	8414RF	8414RF
	1	Cover—on swivel block.....	8356	8414	8414
1968	2	Cap—on cover on swivel block.....	8353	8353	8353
1969	1	Stop—for side plate. Fitted with screw No. 731.....	8106	8106	8106
1970	1	Lid—on cover on swivel block.....	8360	8418	8418
1971	1	Bearing—for worm shaft.....	5588	5589	5589
1972	1	Ring—in cover on swivel block.....	35998	35999	35999
1973	1	Shaft—index.....	8372	8427	8427
1974	1	Gear—on index shaft.....	103492	103494	103494
1975	1	Gear—in cover on swivel block.....	5574	5575	5575
1976	1	Plate—index. Standard.....	6855	6855	6855
	1	Plate—index. No. 1—AB. Special for high numbers.....	10525	10525	10525
	1	Plate—index. No. 2—CD. Special for high numbers.....	10526	10526	10526
	1	Plate—index. No. 3—EF. Special for high numbers.....	10527	10527	10527
1977	1	Carrier—index pin holder. Fitted complete.....	76951F	76951F	76951F
	1	Carrier—index pin holder.....	76951	76951	76951
1978	1	Holder—index pin.....	37750	37750	37750
1979	1	Pin—index, side plate. Fitted complete.....	8083F	8083F	8083F
	1	Pin—index side plate.....	8083	8083	8083
1980	1	Knob—index pin.....	1007	1007	1007
1981	1	Collar—balancing stud.....	76949	76949	76949
1982	1	Stud—balancing.....	76948	76948	76948
1983	1	Sector—bottom and top.....	8100-1	8100-1	8100-1
1984	1	Collar—front of sector.....	8072	8072	8072
1985	1	Plate—CINCINNATI.....	57149	57149	57149
1986	1	Cover—for yoke.....	57150	57151	57151
1987	1	Body—steady rest. Fitted complete.....	8382F	8400FB	8400FA
	1	Body—steady rest.....	8382	8400	8400
1988	1	Stem—steady rest.....	8384	8399	8398
1989	1	Nut—steady rest.....	18977	18977	18977

\*When ordering these parts, return the Dividing Head to our plant for fitting.



# TAILSTOCK AND WIDE RANGE DIVIDER PARTS

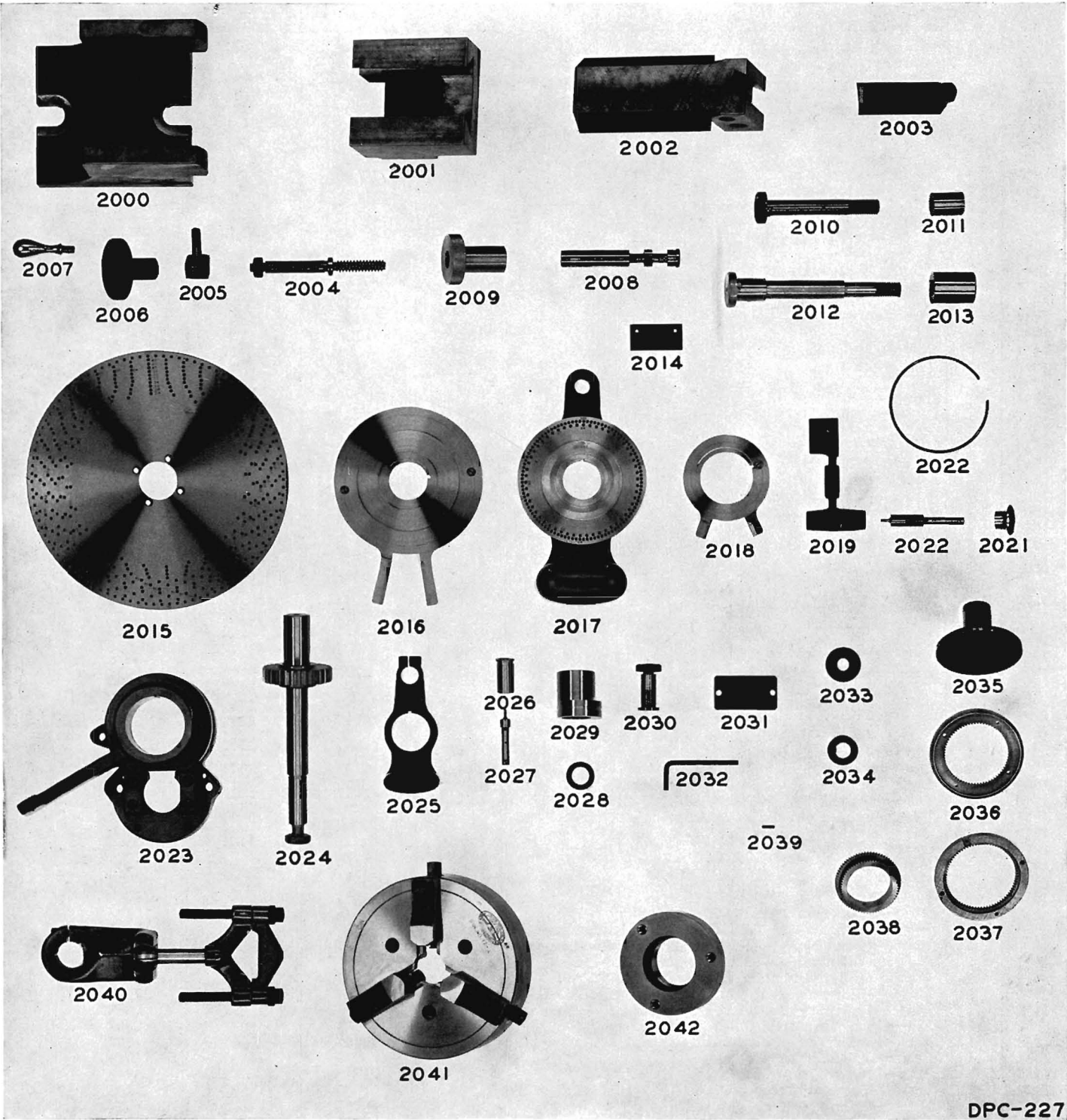

DPC-227

TAILSTOCK AND WIDE RANGE DIVIDER PARTS LIST

Key No.	Amt. Used	PART NAME	PART NUMBER to use when ordering		
			10" Head	12" Head	14" Head
2000	1	Housing.....	60516	60518	60520
2001	1	Block—swivel.....	44183	44181	44181
2002	1	Slide—for tailstock.....	44180	44182	44182
2003	1	Center—elevating.....	8378	8405	8405
2004	1	Screw—tailstock.....	8380	8380	8380
2005	1	Bearing—tailstock screw.....	44184	44184	44184
2006	1	Knob—screw.....	23620	23621	23621
2007	1	Handle.....	1014	1014	1014
2008	1	Pinion.....	8238	8239	8239
2009	1	Knob—on pinion.....	8227	8229	8229
2010	1	Bolt—short tailstock.....	8376	8403	8403
2011	1	Collar—on short bolt.....	8379	8406	8406
2012	1	Bolt—long tailstock.....	8375	8402	8402
2013	1	Bush—in housing.....	8377	8377	8377
2014	1	Plate—over slot.....	6106	6106	6106
<b>Wide Range Divider Parts</b>					
2015	1	Plate—index, large.....	70634	70634	70634
2016	1	Sector—long, top and bottom.....	70625-6	70625-6	70625-6
2017	1	Plate—index.....	71940	71940	71940
2018	1	Sector—short, top and bottom.....	70623-4	70623-4	70623-4
2019	1	Lever—index pin.....	71939	71939	71939
2020	1	Pin—index, long.....	70861	70861	70861
2021	2	Knob.....	70862	70862	70862
2022	1	Spring—ring.....	70613	70613	70613
2023	1	Cover—swivel block.....	70632	70633	70633
2024	1	Shaft. Fitted with gear.....	73015	73016	73016
2025	1	Lever—index pin, small.....	71938	71938	71938
2026	1	Bush—eccentric.....	73009	73009	73009
2027	1	Pin—index, small.....	73008	73008	73008
2028	1	Collar—eccentric bush.....	73010	73010	73010
2029	1	Bushing.....	73011	73011	73011
2030	1	Stud—index pin.....	70622	70622	70622
2031	1	Plate—caution. English.....	79261	79261	79261
2032	1	Wrench. 3/8" hollow set screw.....	35678	35678	35678
2033	1	Washer.....	79253	79253	79253
2034	1	Washer.....	70621	70621	70621
2035	1	Flange—eccentric bearing.....	70616	70616	70616
2036	1	Gear—loose internal.....	70864	70864	70864
2037	1	Gear—fixed internal.....	70863	70863	70863
2038	1	Gear—cluster on eccentric.....	70865	70865	70865
2039	2	Pin.....	3539	3539	3539
<b>Parts Supplied on Demand Only</b>					
2040	1	Dog—compensating and driver.....	24184	24184	24184
2041	1	Chuck. 6".....	103303	.....	.....
	1	Chuck. 9".....	.....	16458	16458
2042	1	Flange—chuck.....	22053	65611	65611

# ENCLOSED DRIVING MECHANISM PARTS

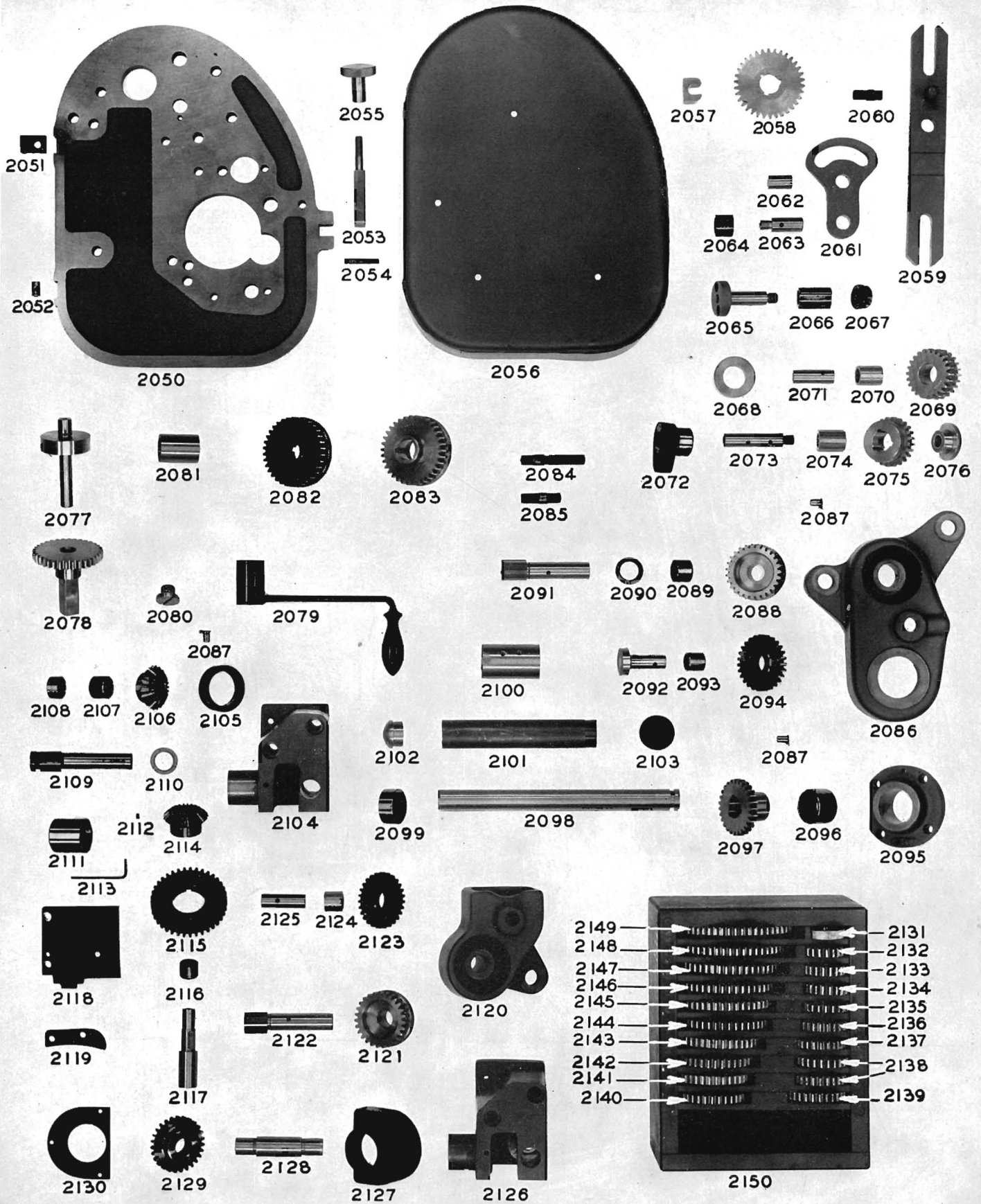

DPC-228

ENCLOSED DRIVING MECHANISM PARTS LIST

Key No.	Amt. Used	PART NAME	PART NUMBER to use when ordering			Key No.	Amt. Used	PART NAME	PART NUMBER to use when ordering		
			10" Head	12" Head	14" Head				10" Head	12" Head	14" Head
2050	1	Plate.....	116530	116530	116530	2101	1	Shield—mitre gear shaft. #3			
2051	2	Block—hinge.....	76510	76510	76510			Machine.....	79470	79470	
2052	2	Hinge—cover.....	76708	76708	76708		1	Shield—mitre gear shaft. #4			
2053	1	Bolt—hinge.....	76443	76443	76443			Machine.....	79342	79342	
2054	1	Pin.....	3544	3544	3544	2102	1	Plug—in shield.....	79341	79341	
2055	1	Knob—hinge bolt.....	75372	75372	75372	2103	1	Plug—1½" diameter.....	3553		
2056	1	Cover—plate.....	116529	116529	116529	2104	1	Bearing—mitre gear.....	79767	79768	79768
2057	1	Block—cover.....	116531	116531	116531	2105	1	Collar.....	79348	79348	79348
2058	2	Gear—drive, 34 teeth.....	76447	76447	76447	2106	1	Gear—mitre.....	8278	8076	8076
2059	1	Bar—sliding change gear.....	77177	77177	77177	2107	2	Bearing—needle. 1" O.D.....	79762	79762	79762
2060	1	Stud—sliding bar.....	85488	85488	85488	2108	1	Spacer—bearing.....	79766	79766	79766
2061	1	Link—change gear.....	77176	77176	77176	2109	1	Gear—mitre gear.....	79764	79764	79764
2062	1	Pin—link.....	75944	75944	75944	2110	1	Washer.....	79765	79765	79765
2063	1	Stud—change gear.....	75344	75344	75344	2111	1	Guard.....	94925	94925	94925
2064	1	Bush—change gear.....	75345	75345	75345	2112	1	Screw.....	216585	216585	216585
2065	1	Stud—plate.....	76445	76445	76445	2113	1	Wrench.....	216584	216584	216584
2066	1	Bush—plate stud.....	76444	76444	76444	2114	1	Gear—mitre.....	8279	8261	8261
2067	4	Collar—nut. ½" diameter.....	76639	76639	76639	2115	1	Gear—on mitre gear.....	8221	8262	8262
2068	1	Collar—spacer.....	77550	77550	77550	2116	1	Bush.....	22829	8259	8259
2069	1	Gear—idler.....	76453	76453	76453	2117	1	Shaft—short.....	8286	8264	8264
2070	1	Bush—idler gear.....	76452	76452	76452	2118	1	Cover—on top of mitre gear bearing.....	57816	57815	57815
2071	1	Stud—idler gear.....	76451	76451	76451			Cover—mitre gear, front.....	8276	8260	8260
2072	1	Bracket—stud.....	77172	77172	77172	2119	1				
2073	1	Stud—bracket.....	76491	76491	76491			<b>Hooded Type Mitre Gear Bearing and Segment</b>			
2074	1	Bush—bracket stud.....	76446	76446	76446			Segment.....	77536	77539	77543
2075	2	Gear—reversing.....	76456	76456	76456	2120	1	Gear—drive. 27 Teeth.....	77173	77173	77173
2076	2	Retainer—reversing gear.....	76454	76454	76454	2121	1	Shaft—reversing gear.....	79769	79769	79769
2077	1	Stud—crank gear.....	76448	76448	76448	2122	1	Gear—intermediate stud.....	75338	76557	77542
2078	1	Gear—crank.....	76450	76450	76450	2123	1	Bush.....	3598	3598	3598
2079	1	Crank—hand.....	3565	3565	3565	2124	1	Stud intermediate.....	77519	77519	77519
2080	1	Screw—crank gear.....	76449	76449	76449	2125	1	Bearing—mitre gear.....	75362	75742	75742
2081	1	Collar—lead screw.....	76511	76511	76511	2126	1	Hood—gear.....	75366	77537	77541
2082	1	Gear—drive.....	77423	77423	77423	2127	1	Shaft—mitre gear.....	75361	75743	75743
2083	1	Gear—drive.....	77422	77422	77422	2128	1	Gear—on mitre gear shaft.....	75360	75360	75360
2084	1	Stud—plate.....	79929	79929	79929	2129	1	Cover—hood.....	75367	77538	77540
2085	1	Stud—housing.....	71740	71740	71740	2130	1	Spacer—change gear.....	75343	75343	75343
		<b>Needle Bearing Type</b>				2131	2	Gear—change. 17 Teeth.....	78322	78322	78322
2086	1	Segment—idler.....	79833	79773	79772	2132	1	Gear—change. 18 Teeth.....	78323	78323	78323
2087	3	Oil.....	44980	44980	44980	2133	1	Gear—change. 19 Teeth.....	78324	78324	78324
2088	1	Gear—drive. 27 teeth.....	77173	77173	77173	2134	1	Gear—change. 20 Teeth.....	78325	78325	78325
2089	2	Bearing—needle. 1" O.D.....	79762	79762	79762	2135	1	Gear—change. 21 Teeth.....	78326	78326	78326
2090	1	Washer.....	79765	79765	79765	2136	1	Gear—change. 22 Teeth.....	78327	78327	78327
2091	1	Shaft—reversing gear.....	105182	105182	105182	2137	1	Gear—change. 24 Teeth.....	78328	78328	78328
2092	1	Stud—intermediate.....	105181	105181	105181	2138	2	Gear—change. 27 Teeth.....	78329	78329	78329
2093	1	Bearing—needle. 1⅜" O.D.....	79761	79761	79761	2139	1	Gear—change. 30 Teeth.....	78330	78330	78330
2094	1	Gear—intermediate stud.....	79755	79758	79759	2140	1	Gear—change. 33 Teeth.....	78331	78331	78331
2095	1	Cover—gear bearing.....	79830	79770	79771	2141	1	Gear—change. 36 Teeth.....	78332	78332	78332
2096	1	Bearing—needle. 1½" O.D.....	79763	79763	79763	2142	1	Gear—change. 39 Teeth.....	78333	78333	78333
2097	1	Gear—mitre gear shaft.....	79345	79345	79345	2143	1	Gear—change. 42 Teeth.....	78334	78334	78334
2098	1	Shaft—splined extension. #3				2144	1	Gear—change. 45 Teeth.....	78335	78335	78335
		Machine.....		79471	79471	2145	1	Gear—change. 48 Teeth.....	78336	78336	78336
	1	Shaft—splined extension. #4				2146	1	Gear—change. 51 Teeth.....	78337	78337	78337
		Machine.....		79349	79349	2147	1	Gear—change. 55 Teeth.....	78338	78338	78338
2099	1	Plug—tube adapter.....		79753	79753	2148	1	Gear—change. 60 Teeth.....	78339	78339	78339
2100	1	Coupling—spline shaft.....		79350	79350	2149	1	Box—for change gears.....	75377	75377	75377



# OPEN TYPE DRIVING MECHANISM PARTS

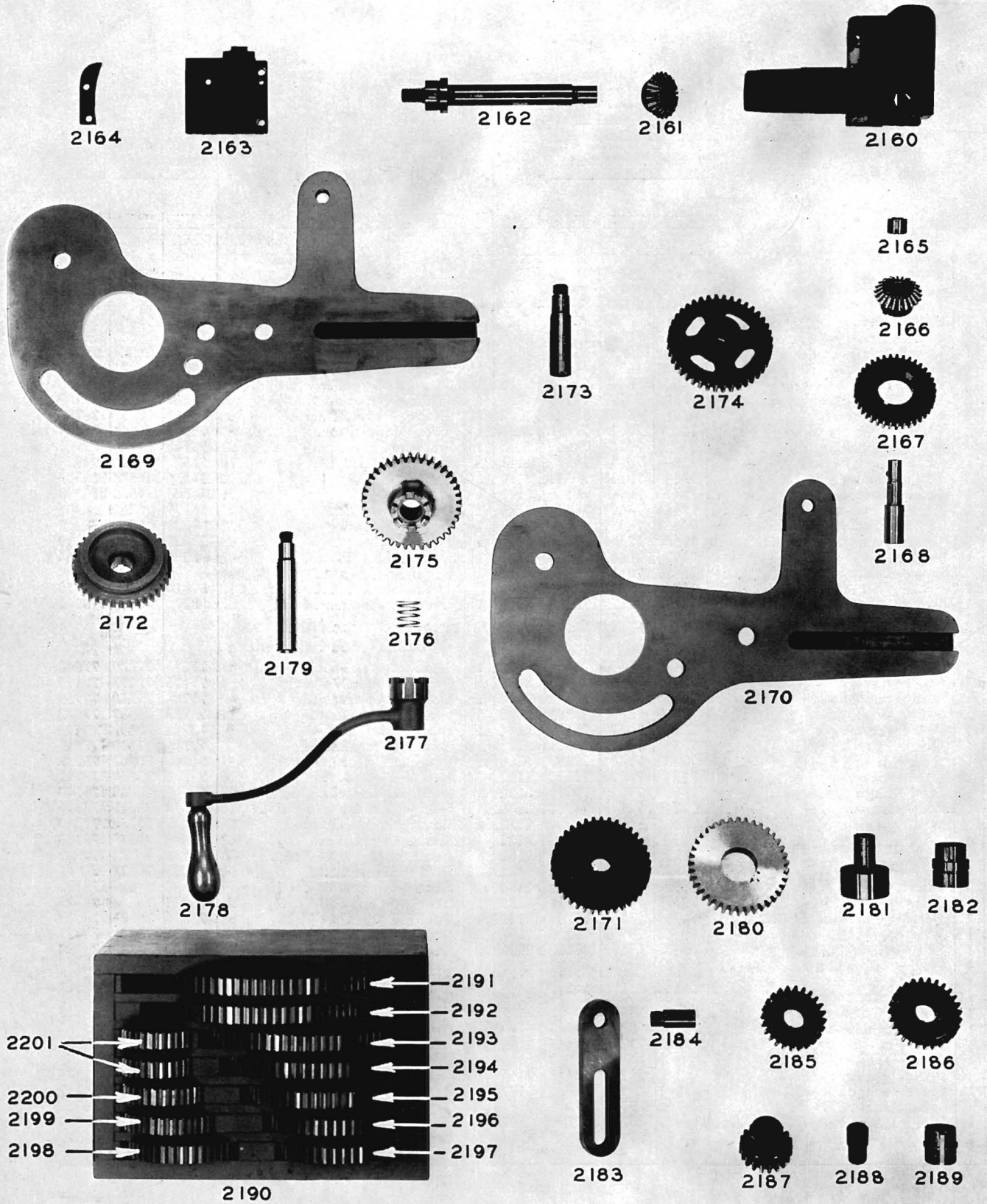

DPC-229



OPEN TYPE DRIVING MECHANISM PARTS LIST

Key No.	Amt. Used	PART NAME	PART NUMBER to use when ordering		
			10" Head	12" Head	14" Head
2160	1	Bearing—mitre gear . . . . .	13956	12087	12087
2161	1	Gear—mitre . . . . .	8278	8076	8076
2162	1	Shaft—change gear . . . . .	13957	12097	12097
2163	1	Cover—top mitre gear bearing . . . . .	57816	57815	57815
2164	1	Cover—front of mitre gear bearing . . . . .	8276	8260	8260
2165	1	Bush—in bearing . . . . .	22829	8259	8259
2166	1	Gear—mitre . . . . .	8279	8261	8261
2167	1	Gear—on mitre gear . . . . .	8221	8262	8262
2168	1	Shaft—short . . . . .	8286	8264	8264
2169	1	Segment. Double pitch lead screw . . . . .	73637	73637	73637
2170	1	Segment. Single pitch lead screw . . . . .	77014	77014	77014
2171	1	Gear—on lead screw. Single spline lead screw . . . . .	12085	12085	12085
2172	1	Gear—on lead screw. Three spline lead screw . . . . .	77025	77025	77025
2173	1	Stud—in segment . . . . .	12098	12098	12098
2174	1	Gear—intermediate . . . . .	9352	9352	9352
2175	1	Gear—quick return stud . . . . .	36365	36365	36365
2176	1	Spring—hand crank . . . . .	33744	33744	33744
2177	1	Crank—clutch . . . . .	56426	56426	56426
2178	1	Handle . . . . .	3505F	3505F	3505F
2179	1	Stud—quick return gear . . . . .	38364	38364	38364
2180		Gear—large on segment. Single pitch lead screw . . . . .	18806	18806	18806
2181	1	Sleeve—change gear bush . . . . .	8065	8065	8065
2182	1	Sleeve—on stud. Single pitch lead screw . . . . .	18808	18808	18808
2183	1	Holder—for intermediate gear . . . . .	12084	12084	12084
2184	1	Stud—in holder . . . . .	12096	12096	12096
2185	1	Gear—small on segment. Single pitch lead screw . . . . .	18807	18807	18807
2186	1	Gear—large on segment. Double pitch lead screw . . . . .	12083	12083	12083
2187	1	Gear—small on segment. Double pitch lead screw . . . . .	12100	12100	12100
2188	1	Stud—for gear segment . . . . .	12099	12099	12099
2189	1	Bush—in change gear . . . . .	8059	8059	8059
2190	1	Box—for change gears . . . . .	67259	67259	67259
2191	1	Gear—change. 100 Teeth . . . . .	5987	5987	5987
2192	1	Gear—change. 86 Teeth . . . . .	5988	5988	5988
2193	1	Gear—change. 72 Teeth . . . . .	5364	5364	5364
2194	1	Gear—change. 64 Teeth . . . . .	5365	5365	5365
2195	1	Gear—change. 56 Teeth . . . . .	5366	5366	5366
2196	1	Gear—change. 48 Teeth . . . . .	5989	5989	5989
2197	1	Gear—change. 44 Teeth . . . . .	5990	5990	5990
2198	1	Gear—change. 40 Teeth . . . . .	5986	5986	5986
2199	1	Gear—change. 32 Teeth . . . . .	48045	48045	48045
2200	1	Gear—change. 28 Teeth . . . . .	48043	48043	48043
2201	2	Gear—change. 24 Teeth . . . . .	48044	48044	48044

**Publication No. M-786-5**

**Printed in U. S. A.  
4M 552K**