

1912

JANUARY

1912

1912

1912

1912

1912

1912

1912

1912

1912

SERVICE MANUAL AND PARTS LIST CATALOG

7130

FOR

CINCINNATI®

No. 2 CUTTER AND TOOL GRINDER

MODEL DO

This catalog was prepared for two primary reasons. First to expedite the ordering of repair parts for your Cincinnati No. 2 Cutter and Tool Grinder; secondly, to present the correct methods of servicing to those responsible for keeping the machine running.

Due to continuing improvements in design, it is possible that some information or the appearance of component parts to be found in this catalog may vary slightly from the machine delivered to you. This indicates that the mechanism has been improved to better fulfill your requirements.

PRICE PER COPY \$10.00

**NOTE: DO NOT ATTEMPT TO OPERATE THIS MACHINE UNTIL YOU
HAVE READ THIS MANUAL THOROUGHLY.**



**CINCINNATI
MILACRON**

Machine Tools | Process Controls | Chemicals | Plastics
Plastics Processing Machinery | Abrasives

CINCINNATI No. 2 CUTTER AND TOOL GRINDER

TABLE OF CONTENTS

SAFETY PRECAUTIONS	M1
FUNCTIONAL DIAGRAMS	M2-M5
DIMENSIONAL DRAWING	M6
INSTALLATION INSTRUCTIONS	
FOUNDATION	M7
LIFTING MACHINE	M7
LEVELING MACHINE	M7
CLEANING	M7
LUBRICATION	M8
ATTACHMENT LUBRICATION	M9
ADJUSTMENTS	
WHEELHEAD DRIVING BELTS	M10
POWER TABLE TRAVERSE	M10
WHEELHEAD SPINDLE BEARINGS	M10
TO ADJUST WORKHEAD SPINDLE BEARINGS	M11
CYLINDER GRINDING ATTACHMENT BELT	M11
GRINDING WHEEL MOUNTING	
GENERAL	M12
CHECK WHEEL SPEED	M12
BEFORE MOUNTING THE GRINDING WHEEL	M12
COLLETS	M13
BLOTTERS	M13
WHEEL MOUNTING HOLES	M13
KEYED WASHER	M13
SPACERS	M14
TIGHTENING THE COLLET NUT	M15

TABLE OF CONTENTS (Concluded)

MOUNTING THE GRINDING WHEEL AND COLLET ASSEMBLY	M15
STARTING THE GRINDING WHEEL SPINDLE	M16
REMOVING THE COLLET	M16
HOW TO ORDER REPAIR PARTS	M17
KEY NUMBER INDEX	RP1-RP3
WHEELHEAD (UNIT NO. 1 DAW)	RP4-RP9
SADDLE TABLE (UNIT NO. 1 DH)	RP10-RP27
WORKHEAD (UNIT NO. 1 GC)	RP28-RP29
BASE (UNIT NO. 1 DAB)	RP30-RP33
COOLANT PUMP AND PIPING (UNIT NO. 1 DP)	RP34-RP35
WORK BLADE GRINDING ATTACHMENT (UNIT NO. 1 DBW)	RP36-RP37
MICROMETER TABLE POSITIONING ATTACHMENT (UNIT NO. 1 DJF)	RP36-RP37
CYLINDRICAL GRINDING ATTACHMENT (UNIT NO. 1 DBT)	RP38-RP39
DRAW-IN BOLT FOR COLLETS (UNIT NO. 1 DJF)	RP38-RP39
HEAVY DUTY TAILSTOCK (UNIT NO. 1 DJF)	RP40-RP41
EXHAUST DUST ATTACHMENT (UNIT NO. 1 DJF)	RP40-RP41
ATTACHMENTS (MISCELLANEOUS) (UNIT NO. 1 DJF)	RP42-RP47
GEAR CUTTER SHARPENING ATTACHMENTS (UNIT NO. 1 DBV)	RP48-RP49
INTERNAL GRINDING ATTACHMENT (UNIT NO. 1 DBP)	RP50-RP51
RADIUS GRINDING ATTACHMENT (UNIT NO. 1 DGB)	RP52-RP55
RADIUS GRINDING ATTACHMENT (UNIT NO. 1 DEJ)	RP56-RP57
FACE MILL GRINDING ATTACHMENT (UNIT NO. 1 DCA)	RP58-RP59
SURFACE GRINDING ATTACHMENT (UNIT NO. 1 DBU)	RP60-RP61
LONG REAMER GRINDING ATTACHMENT (UNIT NO. 1 DBZ)	RP62-RP63
INSTRUCTION PLATES	RP64-RP65

The design and specifications of these machines and attachments illustrated and described herein are subject to change without notice.

LIST OF ILLUSTRATIONS

NOTE: As reference aid, Figure numbers are the same as the page numbers on which they appear. As an example Figure M3 appears on page M3.

FIGURE	TITLE
M2	Right Front of Standard Machine
M3	Rear of Standard Machine
M4	Right Front of Machine with Power Table Traverse
M5	Right Rear of Machine with Power Table Traverse
M6	Dimensional Drawing
M7A	Lifting Diagram
M7B	Area on Underside of Base in Contact with Floor
M9	Lubrication Diagram
M11A	Section Through Workhead
M11B	V-Belt Tension Adjustment
M12	Grinding Wheel Collet Assembly
M13	Keyed Washer Location
M14A	Key Washers
M14B	Wheel Assemblies
M14C	Relieved Spacer with Unrelieved Keyed Washers on 3" Diameter Flange Collets
M15A	Wheel Assembly and Spacer Location
M15B	Wheel Assembly and Spacer Location
M15C	Tightening the Collet Nut
M16A	Mounting the Grinding Wheel and Collet Assembly
M16B	Removing Collet
M17	Machine Serial Number

SAFETY PRECAUTIONS

PROTECT YOUR EYES

Always wear safety glasses or an approved eye shield when operating a grinding machine.

ALWAYS USE A WHEELGUARD

Be certain that the grinding wheel is shielded by the correct wheelguard before starting the machine.

INSPECT GRINDING WHEELS CAREFULLY

Immediately upon receipt, all grinding wheels should be closely inspected to be sure that they have not been damaged in transit.

Before mounting a vitrified grinding wheel, test for cracks as follows: suspend the wheel over a pin through the mounting hole. Tap the periphery of the wheel lightly with a non-metallic implement. An undamaged wheel will emit a clear metallic ring. Resinoid and other organic bonded wheels will not "ring" and must be given a careful visual inspection before use.

NOTE: *Handle all grinding wheels with care to prevent dropping or bumping.*

STORE GRINDING WHEELS IN A CLEAN DRY AREA

Store as close to the machine as possible. Racks, bins or drawers should be provided for safe storage and easy access. The storage area should not be subjected to extremes in temperature or humidity as these conditions sometimes affect resin bonds.

NOTE: *A separate mount is recommended for each wheel in regular use.*

MOUNTING THE GRINDING WHEEL

Read the instructions on mounting grinding wheels, pages M12 - M15.

GRINDING WHEEL SPEED

NEVER RUN A GRINDING WHEEL FASTER THAN THE MAXIMUM SAFE OPERATING SPEED. Grinding wheels are clearly marked with a maximum safe operating speed. This marking appears on the side of the wheel, or on the blatter attached to the wheel. This marking tells, in

revolutions per minute, the maximum safe speed at which the grinding wheel may operate at its maximum diameter.

Also refer to the current American National Standards Institute, Inc. publication B7.1 1964 entitled "The Use, Care, and Protection of Abrasive Wheels."

After the grinding wheel has been properly mounted, start the spindle and let it run for a full minute at operating speed before attempting to grind. **WHEN STARTING THE SPINDLE, DO NOT STAND IN THE GRINDING WHEEL'S PLANE OF ROTATION.**

GENERAL OPERATING RULES

Peripheral grinding wheels should not be used for side grinding because of insufficient support to withstand the pressures exerted. Side grinding shall only be performed with wheels designed for this purpose. Grinding on the flat sides of straight wheels is often hazardous and should not be allowed, especially when the sides of the wheel are appreciably worn or when any considerable or sudden pressure is brought to bear against the sides. Type 6, 11 and 12 wheels are used for side grinding.

Do not "feel" a rotating grinding wheel with a finger to determine the smoothness of the wheel.

Use only grinding wheels of the size and type described on page M10.

Special collets and spindle drive pulleys are required for 8" diameter grinding wheels (see page RP8).

All machines, except those equipped with a mist coolant attachment should be fitted with a dust exhaust system.

WARNING

Do not wear rings, long ties, wrist watches or loose long sleeved shirts when operating this machine.

FUNCTIONAL DIAGRAM

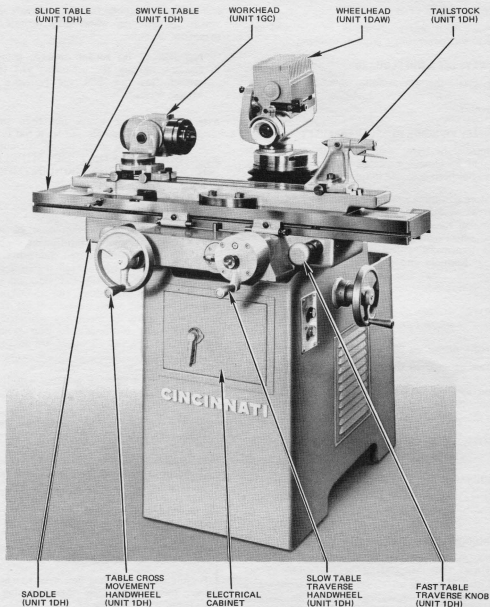

Figure M2
RIGHT FRONT OF STANDARD MACHINE

RAL-178

FUNCTIONAL DIAGRAM

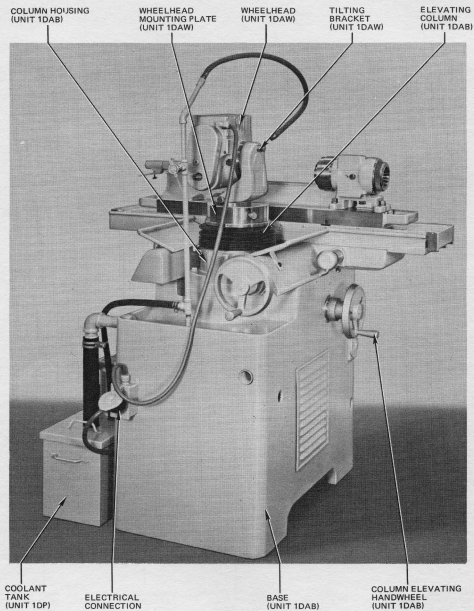

Figure M3
REAR OF STANDARD MACHINE

10256-1

FUNCTIONAL DIAGRAM

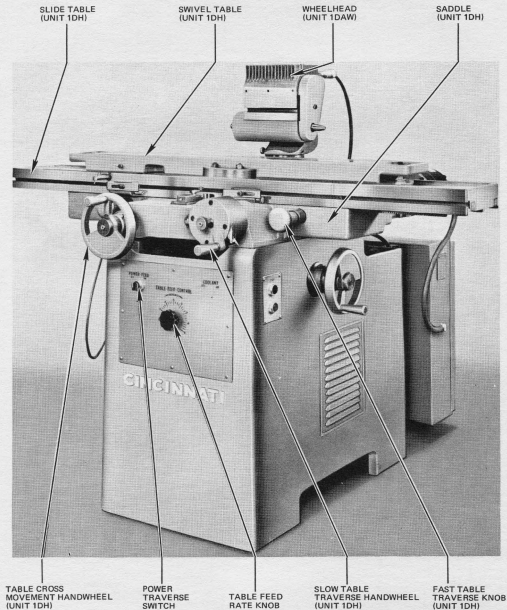

Figure M4
RIGHT FRONT OF MACHINE WITH POWER TABLE TRAVERSE

RAL-179

FUNCTIONAL DIAGRAM

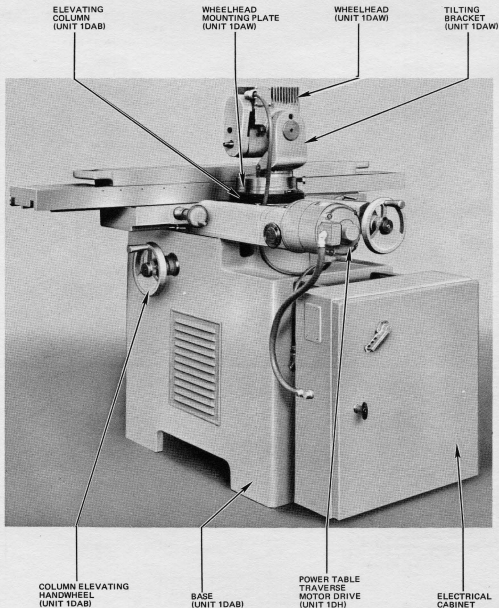
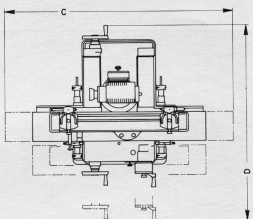
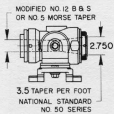
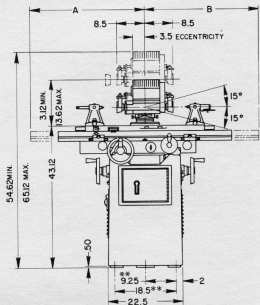
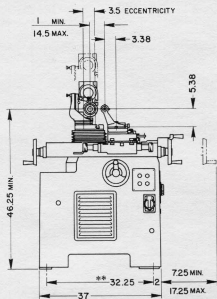

Figure M5
RIGHT REAR OF MACHINE WITH POWER TABLE TRAVERSE

RAL-180

CINCINNATI No. 2 CUTTER AND TOOL GRINDER

DIMENSIONAL DRAWING



MACHINE	A		B		C	D	E	F
	MIN.	MAX.	MIN.	MAX.				
16"	20 1/2	36 1/2	16	32	60 1/2	55 5/8	43	34
24"	25 3/4	47 3/4	19 1/4	43 1/4	91	55 5/8	51	44

WITHOUT POWER FEED ? WITH POWER FEED

**Dimensions for Bolting Machine to Floor

RAL-181

INSTALLATION INSTRUCTIONS

FOUNDATION

A special foundation is not required. Any substantial floor, wood or concrete, fairly flat, and sufficiently heavy to withstand the weight of the machine, will be satisfactory. However, do not locate the machine close to vibrating equipment, as vibration transmitted to the machine will result in a poor finish on the cutting edge of the cutter being sharpened.

The effects of a vibrating foundation may be reduced or entirely eliminated by mounting the machine on a rubber base 3/8" or 1/2" thick. This base may be made by placing a good grade of oilproof rubber between two thin steel sheets. Of course, the rubber selected should have sufficient unit strength to withstand the weight of the machine, which may be as much as 3000 pounds with fixtures.

LIFTING MACHINE (Figure M7A)

The machine may be lifted by a crane with a rope or cable sling around two 1" steel bars through the bed as indicated in Figure M7A. Before lifting the machine be certain to move the saddle to its extreme inner position so it clears the lifting rope to prevent possible damage to machine. The slings

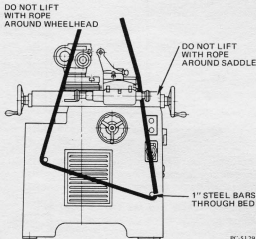

PC-5129

Figure M7A
LIFTING DIAGRAM

should be long enough so that crane lifting hook is approximately 5 feet above table. **DO NOT** attempt to lift this machine by a rope sling around the saddle, or wheelhead spindle.

LEVELING MACHINE (Figure M7B)

For leveling machine tools a sensitive, graduated tube spirit level reading to 10 seconds per graduation (.0005" per foot) is required. A carpenter's level or the bulb in a machinist's combination square is not accurate enough. Table must be clean and free of burrs. Place 6" square pieces of shim stock under bearing pads, illustrated in Figure M7B, until machine is level in all directions. Check and adjust machine level periodically.

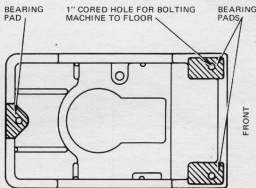

RAI-182

Figure M7B
AREA ON UNDERSIDE OF BASE
IN CONTACT WITH FLOOR

CLEANING

The machine should never be cleaned with the blast from an air hose as it will drive grit and dirt into ways and bearings. Use only lint-free rags for plain surfaces and a stiff bristle brush for corners. Prevent formation of permanent stain by periodic cleaning. If machine will remain idle for a long time, wipe a thin coat of oil over all exposed parts to prevent rust. It is good preventive maintenance to remove the table slide to clean balls and ways periodically. Also remove the saddle occasionally — clean the ways and re-oil. Regardless of guards, the

CINCINNATI No. 2 CUTTER AND TOOL GRINDER

grinding grit in the air around a machine that is dry grinding will settle in the oil film and form a lapping compound to hasten wear. DO NOT oil or

grease the balls under table. Dusting them lightly with colloidal graphite will lubricate the balls in retainer — if lubrication seems advisable.

LUBRICATION

Thoroughly lubricate all moving parts as they are installed. Then add lubricant at points indicated below before starting machine.

Purchase lubricants from reliable dealers. Use lubricant of correct specifications. Do not over-oil. The following schedule is based on a regular eight-hour day.

WHEN TO OIL	STATION NO.	PARTS LUBRICATED	INSTRUCTIONS	LUBRICANT SPECIFICATIONS*
Daily (8 hours)	1 and 2	Column Sleeve and Gears in Base	Fill spring capped oilers (2).	CMMCo. P-47
	3	Workhead — Front and Rear Spindle Bearings	Apply a few drops of oil at oil button — when used.	CMMCo. P-54
	4	Workhead Pulley — Dead Center Operation	Apply a few drops of oil at oil hole — when used.	
	5	Hand Feed Shaft Bearings, Cross Feed Nut, Table Rack and Ways and, if used, Power Feed Bushing.	Align buttons on slide and base; then pull out on plunger and allow it to return by itself. Keep reservoir filled to top of screen filter — approximately 1 quart.	CMMCo. P-47
	6	Retracting Tailstock Center Bearings	Fill spring capped oil cup.	CMMCo. P-54
Weekly (40 hours)	7	Table Drive Gearing — Power Table Traverse Machines only.	Apply 2 or 3 shots of grease at fitting.	CMMCo. P-64

*Consult the latest edition of Publication No. M-2258 for a complete list of lubricants and suppliers for the CMMCo. specifications.

NOTE: *The wheelhead spindle bearings (49A, 30A and 31A, RP4), elevating worm shaft bearings (5 and 10, RP30) and wheelhead motor bearings (12 and 20, RP4) are sealed bearings which are grease packed for the life of the bearing.*

NOTE: *The table slide rides on precision ball bearings. These and the ways should be cleaned and dried occasionally, but should never be oiled or greased, as oily lubricants will eventually pick up grinding grit. After cleaning, dust the balls lightly with colloidal graphite.*

NOTE: *Coolant tank capacity: 8 gallons (30 liters).*

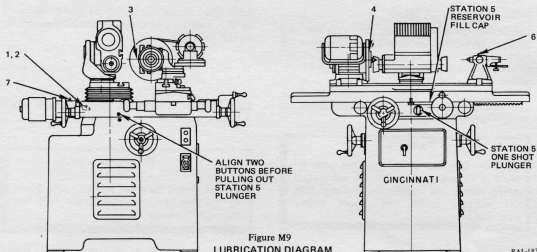

RAL-183

ATTACHMENT LUBRICATION

ATTACHMENT	INSTRUCTIONS	LUBRICANT SPECIFICATIONS
Face Mill Grinding Attachment	Apply several drops of oil, daily when in use, to each of 2 oilers to lubricate the spindle bearings.	CMMCo. P-47
Work Blade Grinding Attachment	Fill 2 oil cups, daily when in use, to lubricate the blade holder bushings.	
Micrometer Table Positioning Attachment	Fill 2 oil cups, daily when in use, to lubricate the lead screw and nut.	
No. 2 Radius Grinding Attachment	Fill 1 oil cup, daily when in use, to lubricate the swivel bearings.	
No. 1 Radius Grinding Attachment	Apply several drops of oil, daily when in use, to one oil button to lubricate the spindle bearings.	CMMCo. P-64
	Swivel bearings are packed at assembly and require no further lubrication, unless disassembled.	
Internal Grinding Attachment	The spindle bearings are permanently sealed and lubricated and require no further lubrication for the life of the bearing.	None

ADJUSTMENTS

WHEELHEAD DRIVING BELTS

The motor and spindle are supplied with two step pulleys for varying the spindle speed to suit the needs of a 3½" or 6" diameter grinding wheel. The 6" diameter wheel is driven by the large spindle pulley (3890 rpm) while the 3½" wheel is driven by the small spindle pulley at 6530 rpm. Thus, both wheels grind with a surface speed of approximately 6000 sfpm.

WARNING

Machines that are to be operated with 8" grinding wheels require special driver and driven pulleys and wheel collet. See page RP8 for correct driver and driven pulley combinations.

All grinding wheels have certain safe peripheral speeds that should not be exceeded. The following

table gives maximum peripheral speeds approved by the American National Standards Institute for certain standard wheels.

To figure the peripheral speed of a grinding wheel use the formula:

$$\text{Surface speed of wheel (ft./min.)} = \frac{\text{spindle rpm} \times 3.1416 \times \text{wheel diameter in inches.}}{12}$$

WARNING

Do not exceed the speed printed on the wheel by the manufacturer if it is lower than that shown in the table.

Always replace belt guard after changing wheel speeds.

AMERICAN NATIONAL STANDARDS INSTITUTE, INC.
MAXIMUM PERIPHERAL SPEEDS FOR GRINDING WHEELS

Classification Number	Types of Wheels	Vitrified and Silicate Bonds			Organic Bonds		
		Low Strength SFPM	Medium Strength SFPM	High Strength SFPM	Low Strength SFPM	Medium Strength SFPM	High Strength SFPM
1	Type 1 - Straight Wheels Type 12 - Dish Wheels Type 13 - Saucer Wheels	5,500	6,000	6,500	6,500	8,000	9,500
2	Types 5 and 7 - Recessed Wheels	5,500	6,000	6,500	6,500	8,000	9,500
3	Type 11 - Flaring Cups	4,500	5,500	6,000	6,000	8,000	9,500
4	Type 6 - Deep Recessed Cup Wheels	4,500	5,000	5,500	6,000	7,500	9,000

POWER TABLE TRAVERSE

The power feed mechanism operates through a selenium rectifier that supplies power to the dc motor drive. The delivered voltage is varied by a powerstat unit to produce infinitely variable feeds to table within a range of from 7 ipm to 90 ipm. The table traverse motor start-stop switch is located at right center of control panel on front of machine, while the powerstat control switch is mounted at the center of the plate (Figure M4).

Disengage the power traverse by swinging the table traverse disengaging lever to the rear position as shown on Figure RP16. Make the necessary job setup by using manual control, then disengage hand knobs.

WHEELHEAD SPINDLE BEARINGS

This spindle is equipped with four axially preloaded ball bearings, two at either end of spindle. If spindle bearings become worn or loose it

is to your advantage to order a rebuilt spindle from us. When it arrives, return your old spindle and you will be allowed credit for any usable parts while you get the accuracy of a guaranteed spindle.

TO ADJUST WORKHEAD SPINDLE BEARINGS (Figure M11A)

1. Loosen three screws "A" through adjusting nut.
2. Tap the adjusting nut lightly to break it loose, hold the forward end of spindle and turn nut by hand until any feeling of spindle looseness

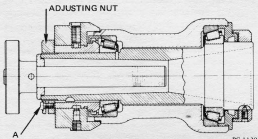

Figure M11A
SECTION THROUGH WORKHEAD

has disappeared.

3. Tighten three screws "A" to lock setting.

CYLINDER GRINDING ATTACHMENT BELT

To adjust the tension on V-belt (23, RP38), loosen screw (12) and move motor (5) away from the spindle to increase belt tension. When properly adjusted, the belt can be deflected $\frac{1}{2}$ " by pressing at a point midway between the two sheaves, see Figure M11B. Tighten screw (12) when the proper tension is obtained.

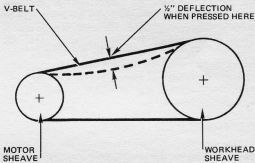

Figure M11B
V-BELT TENSION ADJUSTMENT

RAL-184

GRINDING WHEEL MOUNTING

GENERAL

Statistics show that over half of the wheel breakages that occur in grinding machinery are direct results of improper mounting or storage. Accidents that happen days or even weeks after the wheel has been in use can often be traced directly to some error in the mounting procedure.

Most grinding machines are for single purpose work and are heavily guarded to prevent injury to operators and surrounding personnel if breakage occurs. The complete guarding of cutter grinders however, is virtually impossible because of the very nature and variety of work. It is strongly recommended that the user build special guards to cover as much as possible his own class of work. These guards should be designed to protect not only the operator but those in the vicinity who might be affected in the event of an accident. Properly designed and placed heavy sheet metal or wire mesh screens are excellent protection for surrounding personnel.

CHECK WHEEL SPEED

Before mounting the wheel, check the maximum speed marked on the wheel. This marking appears on the side of the wheel, or on the blotter attached to the wheel. This marking indicates the maximum safe speed, in rpm, that the grinding wheel may operate.

WARNING

Never run a grinding wheel faster than the maximum safe operating speed marked on the wheel.

BEFORE MOUNTING THE GRINDING WHEEL

The following requirements must be met before mounting the grinding wheel on the collet.

1. **Test or Inspect for Cracks** – All vitrified grinding wheels must be “ring tested” before they are mounted. The wheels must be dry and free of packing material when performing the test. Suspend the wheel from the mounting hole and tap the wheel gently with a non-metallic implement. An undamaged

wheel will give a clear ring when tapped. A cracked wheel will sound dead. This test is not valid for resin bond wheels as they do not emit a clear tone in either case. Resin wheels should be visually inspected for damage each time they are mounted.

2. **Inspect Mounting Parts for Flatness** – Check collet clamping nut, keyed washer, spacers, and wheel bearing surface of the collet (Figure M12) for flatness. Coat bearing surfaces of spacers, keyed washer, and collet nut with red lead or prussian blue. Rub bearing surfaces on a surface plate to determine the location of any high spots. High spots should be evenly distributed over the surface being checked. Nicks or burrs should be carefully removed so as not to remove metal below the original machined surface. Spacers and washers should also be checked on a surface plate with a dial indicator, to be certain that both sides are parallel. Coat the wheel bearing area of the collet with a thin film of red lead or prussian blue. Use a flat, precision ground ring with a 1/4" hole to check flatness of the bearing surface. Wheel bearing area must be flat and free of nicks and burrs.

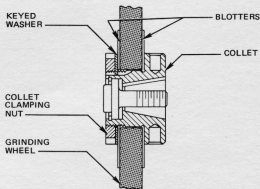

RAL-185

Figure M12
GRINDING WHEEL COLLET ASSEMBLY

3. **Inspect Collet – Spindle Mating Surfaces –**
The tapered hole in the collet and tapered end of the spindle must fit properly when checked with red lead or prussian blue. Spindle keys must fit snugly, but not tight enough to swell the sides of the keyway.

COLLETS

WARNING

Be sure that the collet parts, clamping the grinding wheel, have the same outside diameter and bearing area. Clamping surfaces of different diameters will set up dangerous stresses within the wheel which can cause wheel failure.

When mounting the wheel, be sure that the proper sized collet is used. The following table shows the minimum collet diameter to be used with 6, 7 or 8 inch diameter wheels.

WHEEL DIAMETER	MINIMUM COLLET DIAMETER
6"	2"
7"	2½"
8"	3"

BLOTTERS

Blotters should always be used with all wheels and should be no thicker than 0.025". Never use more than one blotter per side. Where blotters are supplied loose with wheels they should not be re-used. Where the blotters are supplied glued to the wheels they must be carefully inspected for abrasions and scuffing that might result in unequal clamping pressures on the wheel. Any high spots should be carefully removed (see paragraph on Keyed Washers).

WHEEL MOUNTING HOLES

The tensile stress from rotation reaches a maximum value at the hole of the wheel, and from a safety standpoint nothing should be done to increase this stress beyond its normal value, such as forcing or cocking the wheel on the collet. If the fit is tight do not use the wheel or attempt to "open up" the hole.

KEYED WASHERS

When mounting grinding wheels on collets of 6" maximum capacity (2" flange O.D.), the keyed washer, supplied with the collet, should always be used adjacent to the nut and, whenever possible, should be placed next to the blotter of the wheel (see Figure M13). The washer between nut and wheel prevents scuffing of the blotter when the nut is tightened, and also helps to insure that the clamping nut will not "back off" regardless of the wheel rotation.

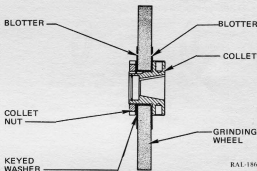

Figure M13
KEYED WASHER LOCATION

NOTE: *The keyed washer supplied with older machines was thinner than the present washer and had a tang or key bent 90° from the face of the washer. This tang prevents the key from rotating through the thread and should always be mounted away from the wheel. If this procedure is not followed, an accident may result from the tang being forced up the radius of the keyway into the bore of the wheel (see Figure M14A).*

When mounting grinding wheels on collets of 8" maximum capacity (3" flange O.D.), use a keyed washer that is relieved on both sides resulting in a bearing area equal to the bearing area of the collet. If the keyed washer is not relieved on both sides, a relieved spacer — having the bearing area equal to the bearing area of the collet — must be used against the blotter of the wheel; then, the keyed

CINCINNATI No. 2 CUTTER AND TOOL GRINDER

washer against the spacer with the blotter on the other side of the wheel against the flange of the collet (see Figures M14B and M14C). It is always preferable to have one of the blotters against the flange of the collet.

Always be sure that the distance between the flange and keyed washer is sufficient to prevent the tang from bottoming in keyway slot. Sometimes spacers are required to accomplish this. If so, read the instructions under SPACERS.

TANG MUST BE AWAY FROM GRINDING WHEEL



BENT KEY WASHER



STRAIGHT KEY WASHER

Figure M14A
KEY WASHERS

RAL-187

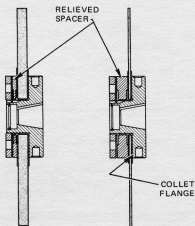

Figure M14B
WHEEL ASSEMBLIES

RAL-188

SPACERS

Spacers are often used to position the grinding wheel on the collet. In using spacers remember that either (a) one of the blotters of the wheel must be in contact with the flange side of the collet, as shown in Figure M15A, or (b) one of the blotters of the wheel must be in contact with a keyed washer, as shown in Figure M15B. Plain spacers (without a tang or key drive) must never be used on each side of the grinding wheel simultaneously as there would be no positive drive and the wheel may slip under heavy cuts. A spacer between the solid flange of the collet and grinding wheel is not recommended; although in rare cases it may be necessary. In these rare cases, the friction between collet flange and spacer is low and the wheel may slip if the keyed washer is not against one of the blotters to drive the grinding wheel. Also, the keyed washer must be in contact with the collet nut.

NOTE: Care must be taken to see that the key of the washer does not bottom in keyway.

Spacers should have a bearing area against the wheel equal to the bearing area of the collet.

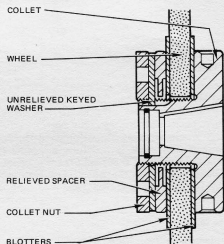
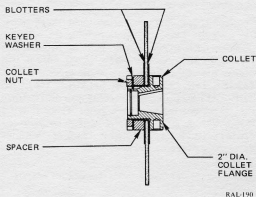

Figure M14C
RELIEVED SPACER WITH UNRELIEVED
KEYED WASHER ON 3" DIAMETER FLANGE COLLETS

RAL-189



RAL-190

Figure M15A
WHEEL ASSEMBLY AND SPACER LOCATION

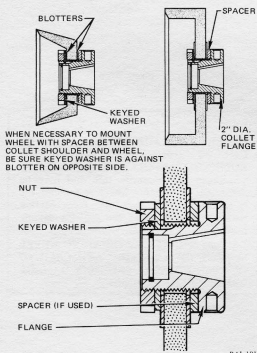

RAL-191

Figure M15B
WHEEL ASSEMBLY AND SPACER LOCATION

TIGHTENING THE COLLET NUT

Two holes are provided in the collet into which a collet pin wrench or pin spanner wrench must be placed to hold the collet while the collet nut is being tightened or removed. Pin diameter must never be smaller than $1/64$ " less than the hole. Smaller pins can cause damage to the wheel bearing surface of the collet (see Figure M15C).

Always use the special pin wrench provided for tightening and removing the collet nut. The collet nut should be seated with a firm pull. Fifteen foot pounds of torque is sufficient. This is approximately the average maximum pull by hand on a four-inch long wrench. NEVER STRIKE THE COLLET WRENCH OR COLLET NUT. If the wrench should slip and strike the wheel, the wheel must be removed and tested for cracks (see page M12).

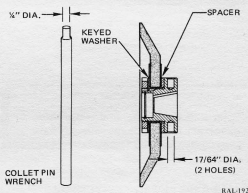

RAL-192

Figure M15C
TIGHTENING THE COLLET NUT

As final check, hold the collet with the pin wrench and be certain the wheel does not turn on the collet.

MOUNTING THE GRINDING WHEEL AND COLLET ASSEMBLY

Align the keyway in the tapered mounting hole in the collet with the driving key on the spindle.

There is a captive socket head screw in the center

of the collet. Start this screw into the threaded hole in the spindle with the T-wrench provided. Place a pin in one of the holes on the collet flange and hold the collet in position while tightening the socket head screw securely.



Figure M16A
MOUNTING THE GRINDING WHEEL
AND COLLET ASSEMBLY

10277

WARNING

Never start the spindle until you are sure the spindle key is seated in the collet keyway.

STARTING THE GRINDING WHEEL SPINDLE

Do not stand in the wheel's plane of rotation. When starting the spindle, stand well to the side and warn personnel in the surrounding area. A good practice is to cover the wheel with a heavy sheet metal drum or can before it is started and allow the wheel to run for a full minute before removing the drum. In any case, allow the wheel to run for a full minute before starting to grind.

REMOVING THE COLLET

To remove the collet, back the socket head screw out with the T-wrench, while holding the collet in position with a pin or pin spanner wrench (see Figure M16B). As the screw backs out, it will unseat the collet from the spindle taper. NEVER STRIKE THE COLLET OR SPINDLE TO FREE THE TAPER. Striking the collet can also deform the wheel bearing area to a point where it is no longer flat. A grinding wheel cannot be mounted against such a deformed surface without developing dangerous stresses.

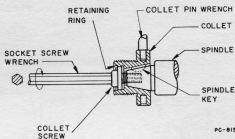

PC-8151

Figure M16B
REMOVING COLLET

CAUTION

NEVER PRY AGAINST THE BACK OF THE COLLET USING THE WHEELHEAD HOUSING AS A FULCRUM. This area of the wheelhead is necessarily thin and may be deformed to a point where it touches the spindle. The heat generated from friction between these surfaces can ruin the spindle bearings.

DO NOT STRIKE THE GRINDING WHEEL SPINDLE OR ANYTHING ATTACHED TO IT! EVEN A "LIGHT TAP" MAY DAMAGE THE SPINDLE BEARINGS.

HOW TO ORDER REPAIR PARTS

You will receive quicker and better service when ordering repair parts if you will adhere to the following instructions when ordering such replacements.

These four requirements are essential:

1. State amount wanted.
2. Give catalog key number, part number and name of part. If ordering parts by part number, please advise where the number was obtained.
 - Number stamped on part.
 - Prior Invoice.
 - Parts List Catalog. (Give identification and publication number on front cover.)
3. Give complete serial number of machine. (The

number can be found stamped at top rear of base. See Figure M17).

4. Specify how and where to ship.

Do not say, "Ship quickest way." Be definite and state agency desired, that is—Air Mail, Parcel Post (Special Delivery), Parcel Post (Regular), Express, Motor Freight, Rail Freight, etc.

Specify each individual piece that is required in the order. If only certain parts of a unit are required, never use the word "complete"; it always raises a question as to how much of a unit to supply.

However, in some cases, due to the nature of the part, it will be necessary and less costly to you for us to supply additional related pieces, especially if part wanted is obsolete.

SERIAL
NUMBER

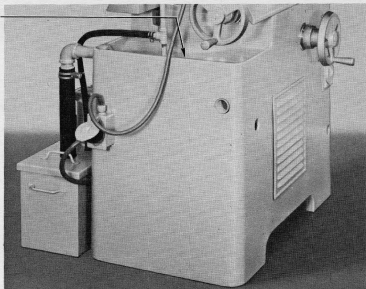

10256-1

Figure M17
MACHINE SERIAL NUMBER

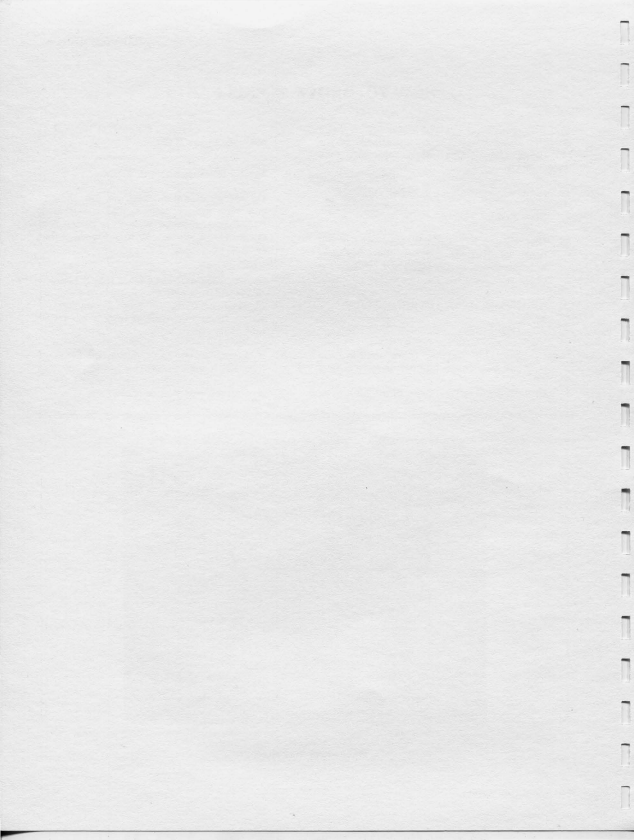

KEY NUMBER INDEX

UNIT NAME	DRAWING NAME	KEY NO.	PAGE NO.	KEY NUMBERS OF OTHER UNITS
WHEELHEAD (UNIT 1DAW)	Housing, Spindle and Drive Tilting Bracket	1-43, 47-54 57-61, 65-90, 145-153	RP-5	
	Wheels, Collets, and Guards	91-137	RP-9	
SADDLE TABLE (UNIT 1DH)	Slide and Swivel Tables (16" Table Travel)	12-51, 615, 662	RP-11	1DP-61 - 66
	Slide and Swivel Tables (24" Table Travel - with or without Power Feed)	103-144 663, 700, 701	RP-13	1DP-96 - 101
	Saddle (16" Table Travel)	269-274, 280, 285, 286, 295, 307, 308, 312-337 664	RP-15	1 DP-67-73
	Saddle, Power Feed (24" Table Travel)	409, 412, 419-425, 428, 431 435-451, 455-464 666-688	RP-17	
	Ball Track, Table Hand Feed, Splash Guard (24" Table Travel)	465-470 479, 484, 485, 504 508-519 544-555 665	RP-19	1DP-74 - 80
	Cross Feed, Slow Table Handfeed (16" and 24" Table Travel)	556, 560-595 600-609 689-694	RP-23	
	Saddle Table Lubrication	620-631, 637, 638 641-647 653-655 696	RP-23	
	Tailstock - Diamond Bracket	192-232, 614	RP-25	
	Blade Support	233-268	RP-27	

CINCINNATI No. 2 CUTTER AND TOOL GRINDER

KEY NUMBER INDEX (Continued)

UNIT NAME	DRAWING NAME	KEY NO.	PAGE NO.	KEY NUMBERS OF OTHER UNITS
WORKHEAD (UNIT IGC)	Workhead Spindle, Draw-In Bolt	145-171, 174-189, 695	RP-29	
BASE (UNIT 1DAB)	Base and Elevating Shaft	1-33, 38-40, 47	RP-31	1DN-42,45,52-54, 1DNN-34-36, 49-51, 56-58 1DM-41, 43, 44
	Column Housing and Sleeve	60-102	RP-33	
COOLANT PUMP & PIPING (UNIT 1DP)	Coolant Pump and Piping	1-19, 23-35, 40-44 55-58 60-62	RP-35	
WORK BLADE GRINDING ATTACHMENT (UNIT 1DBW)	Work Blade Grinding Attachment	1-5 7-22	RP-37	
MICROMETER TABLE POSITIONING ATTACH. (UNIT 1DJF)	Micrometer Table Positioning Attachment	1-25	RP-37	
CYLINDRICAL GRINDING ATTACHMENT (UNIT 1DBT)	Cylindrical Grinding Attachment	1-4, 6-32	RP-39	1DM-5
DRAW-IN BOLT FOR COLLETS (UNIT 1DJF)	Draw-In Bolt, 50-40 N.S.	35-38	RP-39	
HEAVY DUTY TAIL-STOCK ATTACHMENT (UNIT 1DJF)	Heavy Duty Tailstock	39-79	RP-41	
EXHAUST DUST ATTACHMENT (UNIT 1DJF)	Dust Exhaust	193	RP-41	
MISCELLANEOUS ATTACHMENTS (UNIT 1DJF)	Cutter Sharpening Arbor	149-152	RP-43	
	Saw Sharpening and Side Mill	153-158	RP-43	
	Draw-In Collet Attachment	159-165	RP-43 RP-45	
	Slot Indexing Attachment	166-180	RP-47	
	2" Raising Block	185-190	RP-47	
	Reducing Collet	191	RP-47	
	Face Mill Adapter	192	RP-47	

KEY NUMBER INDEX (Concluded)

UNIT NAME	DRAWING NAME	KEY NO.	PAGE NO.	KEY NUMBERS OF OTHER UNITS
GEAR CUTTER SHARPENING ATTACH. (UNIT 1DBV)	Gear Cutter Sharpening Attachment	1-39	RP-49	
INTERNAL GRINDING ATTACHMENT (UNIT 1DBP)	Internal Grinding Attachment	1-48	RP-51	
RADIUS GRINDING ATTACHMENT NO. 1 (UNIT 1DGB)	No. 1 Radius Grinding Attachment	1-77	RP-53	
	No. 1 Radius Grinding Attachment	78-141 145-148	RP-55	
RADIUS GRINDING ATTACHMENT NO. 2 (UNIT 1DEJ)	No. 2 Radius Grinding Attachment	1-85	RP-57	
FACE MILL GRINDING ATTACHMENT (UNIT 1DCA)	Face Mill Grinding Attachment	7-46 51-55	RP-59	IDAW-138 - 144 IDJF-197, 198
SURFACE GRINDING ATTACHMENT (UNIT 1DBU)	Surface Grinding Attachment	1-30	RP-61	
LONG REAMER GRINDING ATTACHMENT (UNIT 1DBZ)	Long Reamer Grinding Attachment	1-56	RP-63	
	Instruction Plates	1-8	RP-65	

CINCINNATI No. 2 CUTTER AND TOOL GRINDER

WHEELHEAD

HOUSING, SPINDLE AND DRIVE

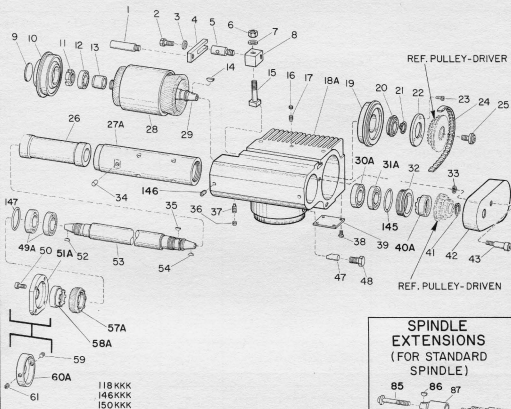

TILTING BRACKET

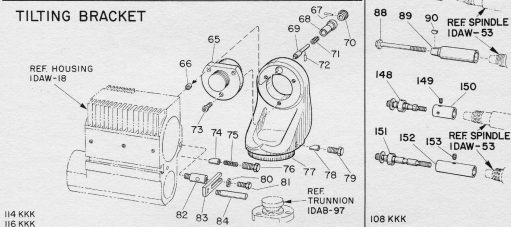

SPINDLE EXTENSIONS (FOR STANDARD SPINDLE)

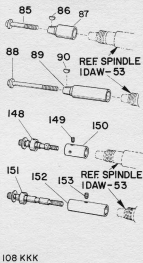

WHEELHEAD-UNIT 1 DAW

KEY NO.	PART NO.	PART NAME	AMT. USED	KEY NO.	PART NO.	PART NAME	AMT. USED
IDAW-1		Stud - Wheel Guard		IDAW-48	741	Screw - Hex Head Set (Without Tilting Bracket)	2
	189640	For Pulley End Wheel Guard	1	IDAW-49A	309504	Bearing - Ball	2
	189640	For Front End Wheel Guard, Standard Spindle	1	IDAW-50	3396	Screw - Cap (With Standard Spindle)	4
	189641	For Front End Wheel Guard, 2" Extended Spindle	1	IDAW-51A	309560	Cap (With Standard Spindle)	1
	189642	For Front End Wheel Guard, 4" Extended Spindle	1	IDAW-52	3279	Key - Hi-Pro Spindle	1
IDAW-2	49	Screw - Hex Head	2	IDAW-53	191662	Standard	1
IDAW-3	3441	Washer	2		191663	4" Extended	1
IDAW-4	189638	Arm - Wheel Guard	2	IDAW-54	3279	Key - Hi-Pro	1
IDAW-5	189637	Stud - Extension	2	IDAW-57A	309564	Nut - Adjusting	1
IDAW-6	3479	Nut - Hex (Without Tilting Bracket)	2	IDAW-58A	309562	Nut - Retainer, Front	1
IDAW-7	3442	Washer (Without Tilting Bracket)	2	IDAW-59	2354	Screw - Set (With 4" Extended Spindle)	1
IDAW-8	189639	Block - Guard Mounting (Without Tilting Bracket)	2	IDAW-60A	309561	Guard - Dust (With 4" Extended Spindle)	1
				IDAW-61	2354	Screw - Set (With 4" Extended Spindle)	1
IDAW-9	69490	Plug	2	IDAW-65	149625	Transition	1
IDAW-10	173324	Bell - End, Front	1	IDAW-66	143965	Bushing	1
IDAW-11	606854	Nut - Lock	1	IDAW-67	140	Pin - Taper	1
IDAW-12	191667	Bearing - Ball	1	IDAW-68	181977	Housing - Shot Pin	1
IDAW-13	173321	Spacer	1	IDAW-69	181976	Plunger - Shot Pin	1
IDAW-14	3279	Key - Hi-Pro	1	IDAW-70	126873	Knob - Knurled	1
IDAW-15	3274	Bolt - Tee (Without Tilting Bracket)	2	IDAW-71	3954	Spring - Compression	1
IDAW-16	2355	Screw - Set	3	IDAW-72	3270	Pin	1
IDAW-17	279865	Screw - Set	3	IDAW-73	3399	Screw - Cap	1
IDAW-18A	309559	Housing - Wheelhead	1	IDAW-74	199636	Plug - Locking	2
IDAW-19	173324	Bell - End, Rear	1	IDAW-75	33000	Spring - Compression	2
IDAW-20	191651	Bearing - Ball	1	IDAW-76	189646	Screw - Locking	2
IDAW-21	137926	Ring - Retaining	1	IDAW-77	189633	Bracket - Tilting	1
IDAW-22	173322	Retainer	1	IDAW-78	189636	Plug - Locking	2
IDAW-23	3194	Screw - Cap	3	IDAW-79	741	Screw - Hex Head Set	2
IDAW-24	143833	Belt - Timing	1	IDAW-80	3441	Washer	2
IDAW-25	143627	Screw	1	IDAW-81	49	Screw - Hex Head	2
IDAW-26		Spacer - Bearing		IDAW-82	189637	Stud - Extension	2
	171377	Standard Spindle	1	IDAW-83	189638	Arm - Wheel Guard	2
	172746	4" Extended Spindle	1	IDAW-84		Stud - Wheel Guard	1
IDAW-27A		Sleeve - Bearing			189640	For Front End Wheel Guard, Standard Spindle	1
	309566	Standard Spindle	1		189641	For Front End Wheel Guard, 2" Extended Spindle	1
	309565	4" Extended Spindle	1		189642	For Front End Wheel Guard, 4" Extended Spindle	1
IDAW-28	Example	*Motor	1	IDAW-85	156171	Screw	1
IDAW-29	173323	Shaft - Motor	1	IDAW-86	3279	Key - Hi-Pro	1
IDAW-30A	309604	Bearing - Ball	1	IDAW-87	156172	Extension - Spindle, 2"	1
IDAW-31A	309604	Bearing - Ball	1	IDAW-88	156174	Screw	1
IDAW-32	171393	Nut - Retainer	1	IDAW-89	156173	Extension - Spindle, 4"	1
IDAW-33	184617	Ring - Retaining	1	IDAW-90	3279	Key - Hi-Pro	1
IDAW-34	171383	Pin	1	IDAW-145	308832	Ring - "O"	1
IDAW-35	3280	Key - Hi-Pro	1	IDAW-146	4236	Ring - Pipe	2
IDAW-36	2354	Screw - Set	4	IDAW-147	308832	Ring - "O"	1
IDAW-37	3230	Screw - Set	4	IDAW-148	158169	Screw - Extension Spindle	1
IDAW-38	2369	Screw - Button Head Cap	4	IDAW-149	3226	Screw - Set	1
IDAW-39	189645	Cover - Electrical Cavity	1	IDAW-150	158170	Collar - Extension Spindle	1
IDAW-40A	309563	Nut - Retainer, Rear	1	IDAW-151	305887	Screw - Extension Spindle, 4"	1
IDAW-41	159882	Ring - Retaining	1	IDAW-152	305886	Collar - Extension Spindle, 4"	1
IDAW-42	184618	Cover - Drive	1	IDAW-153	3226	Screw - Set	1
IDAW-43	184616	Screw	1				
IDAW-47	189636	Plug - Locking (Without Tilting Bracket)	2				

*When ordering a replacement part, specify part number (if available), part name, all part characteristic data available and the serial number of your machine.

CINCINNATI No. 2 CUTTER AND TOOL GRINDER

WHEELHEAD

HOUSING, SPINDLE AND DRIVE

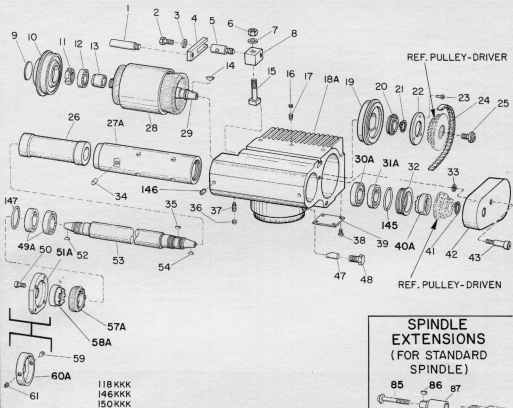

TILTING BRACKET

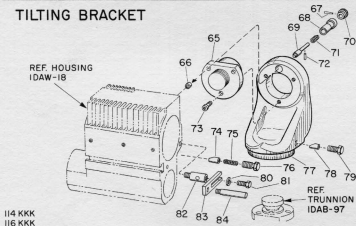

SPINDLE EXTENSIONS (FOR STANDARD SPINDLE)

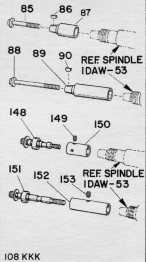

TO REMOVE GRINDING WHEEL SPINDLE (53, RP4)

1. Remove spindle drive cover (42) and belt (24, RP4). Remove spindle lock screw (115 or 120, RP8) and collet (112 or 117) with grinding wheel, from one or both ends of spindle.
2. Remove retaining ring (41, RP4) and slip driven pulleys off spindle. On machine without 4" extended spindle, remove four screws (50) and cap (51) from front end of spindle. Remove eight screws (36 and 37) and slip bearing retainer sleeve (27) with spindle assembly out of wheelhead housing.

Ship this assembly back to our factory for credit and install a new factory guaranteed spindle. Make certain that driver and driven pulleys are in line when assembling.

TO REMOVE TILTING BRACKET (77, RP4) FROM WHEELHEAD

1. Proceed per instructions in paragraphs 1, 2, and 3, page RP33.
2. Place wheelhead on bench with knob (70, RP4) up. Remove screw (76), spring (75), and plug (74) from each side of wheelhead. Lift tilting bracket (77) with trunnion (65) and locking device (69-72) from wheelhead.

TO REMOVE WHEELHEAD MOTOR SHAFT (29, RP4)

1. Remove belt guard (42, RP4) belt and driver pulley assembly.
2. Remove screws (16, 17, RP4) on front end and remove Front End Bell (10). Push spindle (29) with armature out pulley end of housing. (Motor shaft, with all rotating parts should be dynamically balanced before installation.)

CINCINNATI No. 2 CUTTER AND TOOL GRINDER

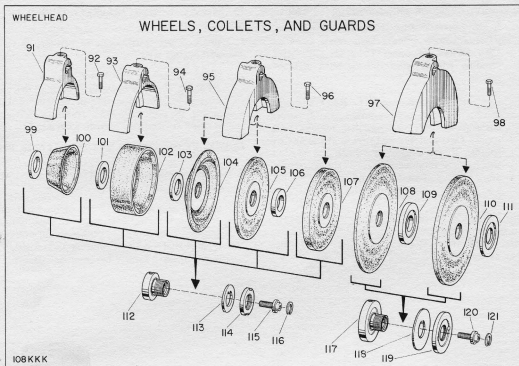

108KKK

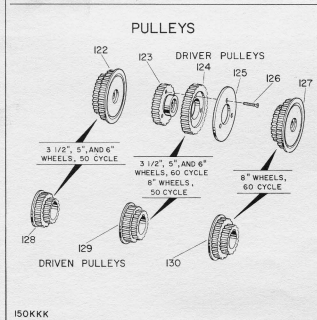

150KKK

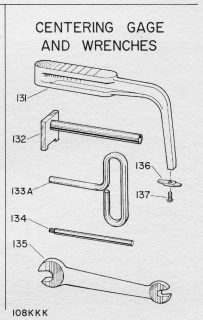

108KKK

WHEELHEAD - UNIT 1 DAW (Concluded)

KEY NO.	PART NO.	PART NAME	AMT. USED	KEY NO.	PART NO.	PART NAME	AMT. USED
1DAW-91	69492	Guard - Wheel, Flaring Cup	1	1DAW-111	157754	Collar - 1/8"	1
1DAW-92	49	Screw - Hex Head	1	1DAW-112	188706	Collet - Grinding Wheel	5
1DAW-93	62270	Guard - Wheel, Straight Cup	1	1DAW-113	188828	Washer - Keyed	5
1DAW-94	49	Screw - Hex Head	1	1DAW-114	67789	Nut - Collet	5
1DAW-95	62269	Guard - Wheel, Disc	1	1DAW-115	143627	Screw	5
1DAW-96	49	Screw - Hex Head	1	1DAW-116	188711	Ring - Retaining	5
1DAW-97	65376	Guard - Wheel, 8"	1	1DAW-117	188705	Collet - Grinding Wheel	1
1DAW-98	49	Screw - Hex Head	1	1DAW-118	188829	Washer - Keyed	1
1DAW-99	67784	Collar - 1/8"	1	1DAW-119	157756	Nut - Collet	1
1DAW-100	67783	Wheel - Grinding, 3-1/2" x 1-1/2" x 1-1/4" Flaring Cup	1	1DAW-120	143627	Screw	1
1DAW-101	67784	Collar - 1/8"	1	1DAW-121	188711	Ring - Retaining	1
1DAW-102	62277	Wheel - Grinding, 5" x 1-1/2" x 1-1/4" Straight Cup	1	1DAW-122	161813	Pulley - Driver	1
1DAW-103	67784	Collar - 1/8"	1	1DAW-123	143630	Pulley - Driver, Low Speed	1
1DAW-104	60481	Wheel - Grinding, 6" x 3/4" x 1-1/4" Dished	1	1DAW-124	143631	Pulley - Driver, High Speed	1
1DAW-105	67782	Wheel - Grinding, 6" x 1/8" x 1-1/4" Straight	1	1DAW-125	143736	Flange - Driver Pulley	1
1DAW-106	67785	Collar - 3/8"	1	1DAW-126	3200	Screw - Cap	3
1DAW-107	60479	Wheel - Grinding, 6" x 1/2" x 1-1/4" Straight	1	1DAW-127	165204	Pulley - Driver	1
1DAW-108	74012	Wheel - Grinding, 8" x 1/16" x 1-1/4" Straight Side	1	1DAW-128	191664	Pulley - Driver	1
1DAW-109	157755	Collar - 3/8"	1	1DAW-129	191665	Pulley - Driver	1
1DAW-110	65613	Wheel - Grinding, 8" x 3/8" x 1-1/4" Straight Side	1	1DAW-130	191666	Pulley - Driver	1
				1DAW-131	154408	Bracket - Centering Gage	1
				1DAW-132	157757	Wrench - Collet Nut	1
				1DAW-133A	309442	Wrench - Tee	1
				1DAW-134	62281	Wrench - Pin	1
				1DAW-135	19476	Wrench - Open End	1
				1DAW-136	65815	Plate - Centering Gage	1
				1DAW-137	3460	Screw	1

CINCINNATI No. 2 CUTTER AND TOOL GRINDER

SADDLE TABLE

SLIDE & SWIVEL TABLES 16" TABLE TRAVEL

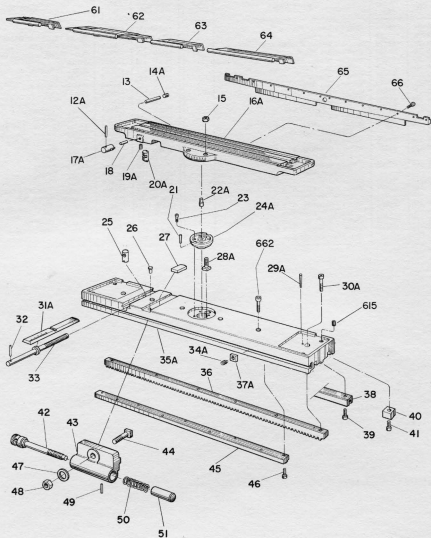

126KKK
127KKK

SADDLE TABLE-UNIT 1 DH

KEY NO.	PART NO.	PART NAME	AMT. USED	KEY NO.	PART NO.	PART NAME	AMT. USED
IDH-12A	3542	Pin	1	IDH-34A	3453	Screw	2
IDH-13	149574	Pin - Adjusting	1	IDH-35A	191647	Slide - Table	1
IDH-14A	180270	Screw - Set	1	IDH-36	149570	Rack - On Table	1
IDH-15	8479	Nut	2	IDH-37A	133897	Stop - Limit	2
IDH-16A	191632	Table - 16" Table Travel	1	IDH-38	70950	Track - Ball	8
IDH-17A	160013	Eccentric	1	IDH-39	3396	Screw	1
IDH-18	3636	Pin	1	124975		Screw (Left end only)	4
IDH-19A	172444	Screw	1	IDH-40	93159	Block - Filler	4
IDH-20A	160012	Finger	1	IDH-41	3399	Screw	2
IDH-21	1857	Pin - Taper	1	IDH-42	67043	Screw - Thumb	2
IDH-22A	159905	Pin - Table Swivel	1	IDH-43		Dog	1
IDH-23	3482	Screw	3	64962		Right Hand	1
IDH-24A	159910	Trunnion - Table Clamp	1	64961		Left Hand	2
IDH-25	69912	Nut - Hand Adjusting Screw	1	IDH-44	3328	Bolt - Tee	1
IDH-26	143702	Pin - Locating	1	IDH-45	93135	Ball - Ball	9
IDH-27		Block - Set	1	IDH-46	3396	Screw	2
	149573	3-1/2" Inch System	1	IDH-47	125	Washer	2
	158482	Metric	1	IDH-48	664	Nut	2
	143687	1" Inch System	1	IDH-49	3383	Pin	2
	158480	Metric	1	IDH-50	1740	Spring	2
IDH-28A	193307	Bolt - Tee	2	IDH-51	64963	Plunger	1
IDH-28A	1894	Pin	1	IDP-61	159949	Guard - Table, Splash, 9-3/4" Long	1
IDH-30A	3402	Screw	2	IDP-62	159950	Guard - Table, Splash, 13-1/4" Long	1
IDH-31A		Plate - Table Adjusting	1	IDP-63	159948	Guard - Table, Splash, 5" Long	1
	160016	Inch System	1	IDP-64	159951	Guard - Table, Splash, 15-3/4" Long	1
	196477	Symbolized	1	IDP-65	159918	Trough - Coolant, Slide	15
	160018	Metric	1	IDP-66	2368	Screw	4
	305280	Symbolized	1	IDH-615	1154	Screw	4
IDH-32	3377	Pin	1	IDH-662	3192	Screw	1
IDH-33	69915	Screw - Table Adjusting	1				



Figure RP11
TABLE SLIDE AND BALL TRACK

3151-6-4

TO REMOVE TABLE (16A, RP10)

(Instructions are referenced to 16" table. Procedure is the same for all sizes.)

- Strip attachments from top of table. Unscrew two 1/2" swivel clamping nuts (15, RP10) from front of table.
- Turn swivel adjustment disengaging eccentric (17A, RP10) so pin (12A) points straight up; swivel table and lift it straight up off clamping T-bolts. Table weighs over 60 lbs.

TO REMOVE TABLE SLIDE (35A, RP10)

- Strip attachments and dogs (43, RP10) from table. Disengage table traverse knobs and slow movement crank. (Pull out hand shaft knobs 327, RP14 and 600, RP20.)
- Push table slide to right and then to left far enough to remove safety studs (280, RP14) from both ends of saddle. (Hold up outer end of table as it is moved.) Attach table to a crane using four eye bolts in place of four screws (615). Sling rope or cable through two eye bolts and lift table slide straight up.

If no crane is available, it is possible to slide table slide off one side after first removing filler blocks (40, RP10) from the opposite end. When replacing, exercise extreme caution not to knock any balls out of their cage. The table slide is quite heavy - 180 lbs., by itself and 240 lbs., in combination with table.

CINCINNATI No. 2 CUTTER AND TOOL GRINDER

SADDLE TABLE

SLIDE & SWIVEL TABLES

24" TABLE TRAVEL

WITH OR WITHOUT POWER FEED

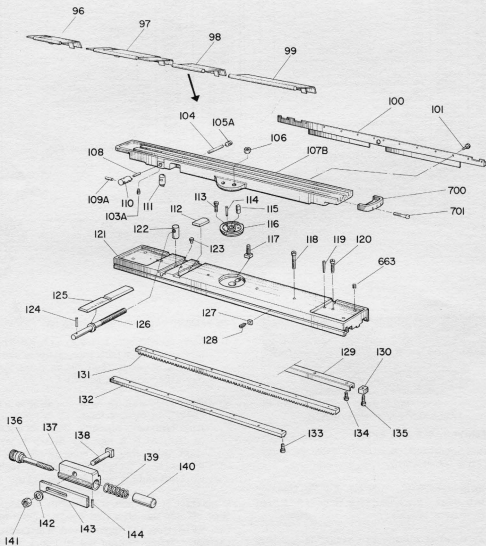

127KKK
131KKK
145KKK

SADDLE TABLE - UNIT 1 DH (Continued)

KEY NO.	PART NO.	PART NAME	AMT. USED	KEY NO.	PART NO.	PART NAME	AMT. USED
IDP-96	158949	Guard - Table, Splash, 9-3/4" Long . . .	1	IDH-125		Plate - Table Adjusting	
IDP-97	158950	Guard - Table, Splash, 13-1/4" Long . . .	1	160016	Inch System		1
IDP-98	158948	Guard - Table, Splash, 5" Long	1	196477	Symbolized		1
IDP-99	158951	Guard - Table, Splash, 16-3/4" Long . . .	1	160018	Metric		1
IDP-100	158918	Trough - Coolant, Slide	1	305280	Symbolized		1
IDP-101	2368	Screw	15	IDH-126	69915	Screw - Table Adjusting	1
IDH-103A	172444	Screw	1	IDH-127	133897	Stop - Limit	2
IDH-104	148574	Pin - Adjusting	1	IDH-128	3453	Screw	2
IDH-105A	180270	Screw	1	IDH-129	159912	Track - Ball	1
IDH-106	3479	Nut	2	IDH-130	93159	Block - Filler	4
IDH-107B	303995	Table - Swivel	1	IDH-131	159902	Rack - On Table	1
IDH-108	3636	Pin	1	IDH-132	159911	Rail - Ball	1
IDH-109A	3342	Pin	1	IDH-133	3396	Screw	10
IDH-110	160013	Eccentric	1	IDH-134	3396	Screw	10
IDH-111	160012	Finger	1	IDH-135	3399	Screw	4
IDH-112		Block - Set, 3-1/2" x 1"		IDH-136	67041	Screw - Thumb	2
	149573	3-1/2" Inch System	2	IDH-137		Dog - Table	
	136482	Metric	2	64962	Right Hand (Without Power Feed) . . .		1
	143687	1" Inch System	2	64961	Left Hand (Without Power Feed) . . .		1
	158480	Metric	2	159907	Right Hand (With Power Feed)		1
IDH-113	3399	Screw	4	159906	Left Hand (With Power Feed)		1
IDH-114	1857	Pin - Taper	1	IDH-138		Bolt - Tee	
IDH-115	158909	Pin - Table, Swivel	1	3328	Without Power Feed		2
IDH-116	158910	Trunnion	1	113286	With Power Feed		2
IDH-117	126833	Bolt - Tee	2	IDH-139	1740	Spring	2
IDH-118	3192	Screw	5	IDH-140	64963	Plunger	2
IDH-119	1894	Pin	1	IDH-141	664	Nut	2
IDH-120	3402	Screw	2	IDH-142	125	Washer	2
IDH-121	160015	Table - Slide	1	IDH-143	159908	Plate - Limit Switch Trip (With Power Feed)	2
IDH-122	69912	Nut - Hand Adjusting Screw	1	IDH-144	3383	Pin	2
IDH-123	143702	Pin - Locating	1	IDH-653	1154	Screw	4
IDH-124	3277	Pin	1	IDH-700	303996	Trough - Table End	1
				IDH-701	3217	Screw	3

CINCINNATI No. 2 CUTTER AND TOOL GRINDER

SADDLE TABLE

SADDLE 16" TABLE TRAVEL

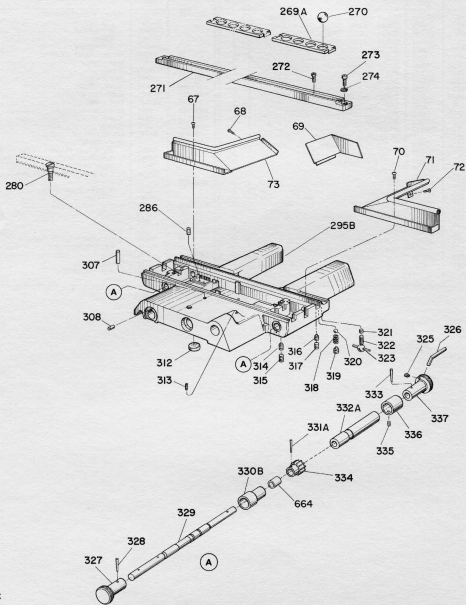

12BKKK
131KKK

SADDLE TABLE—UNIT 1 DH (Continued)

KEY NO.	PART NO.	PART NAME	AMT. USED	KEY NO.	PART NO.	PART NAME	AMT. USED
IDP-67	2368	Screw	1	IDH-316	1917	Screw	2
IDP-68	2375	Screw	1	IDH-317	3232	Screw	2
IDP-69	193390	Guard - Splash, L. H. Rear	1	IDH-318	262	Spring	2
IDP-70	2368	Screw	1	IDH-319	3232	Screw	2
IDP-71	191659	Guard - Splash, R. H.	1	IDH-320	13665	Ball - 5/16" Diameter	2
IDP-72	2375	Screw	1	IDH-321	1962	Flag	2
IDP-73	191658	Guard - Splash, L. H.	1	IDH-322	3536	Screw	2
IDH-269A	184646	Cage - Ball	10	IDH-323	3537	Handle	2
IDH-270	68489	Ball - 3/4"	40	IDH-325	1911	Screw	2
IDH-271	78678	Track - Ball	2	IDH-326	67947	Lever - Shaft, Hand Feed	2
IDH-272	3396	Screw	18	IDH-327	129716	Knob - Hand Shaft	2
IDH-273	3400	Screw	4	IDH-328	642	Pin - Taper	2
IDH-274	2135	Washer	4	IDH-329	126815	Shaft - Hand Feed	2
IDH-280	140209	Stud - Safety	4	IDH-330B	191654	Bushing - Front, Hand Feed Shaft	2
IDH-285	2209	Screw	1	IDH-331A	148097	Pin - Taper	2
IDH-286	2251	Plug	2	IDH-332A	180223	Bushing - Rear, Hand Feed Shaft	2
IDH-295B	184633	Saddle - 16" Table Travel	1	IDH-333	642	Pin - Taper	2
IDH-307	68205	Pin	1	IDH-334	107411	Pinion	2
IDH-308	79980	Pin - Index	2	IDH-335	3228	Screw	2
IDH-312	3559	Plug - 3"	1	IDH-336	79962	Guard - Hand Feed Shaft Bushing	2
IDH-313	3233	Screw	1	IDH-337	130019	Knob - Shaft	2
IDH-314	3233	Screw	2	IDH-664	191653	Bushing - Oilite	2
IDH-315	3211	Screw	2				

TO REMOVE HAND FEED SHAFT (329, RP14)

1. Drive out taper pin (328, RP14) and remove front hand shaft knob (327).
2. Push table slide to opposite side far enough to drive taper pin from pinion (334). (Block up under extended end of table.)
3. Loosen clamp (323, RP14), remove set screw (319), spring (318) and ball (320). Pull hand feed shaft out the back of saddle.

CINCINNATI No. 2 CUTTER AND TOOL GRINDER

SADDLE TABLE

SADDLE, POWER FEED

24" TABLE TRAVEL

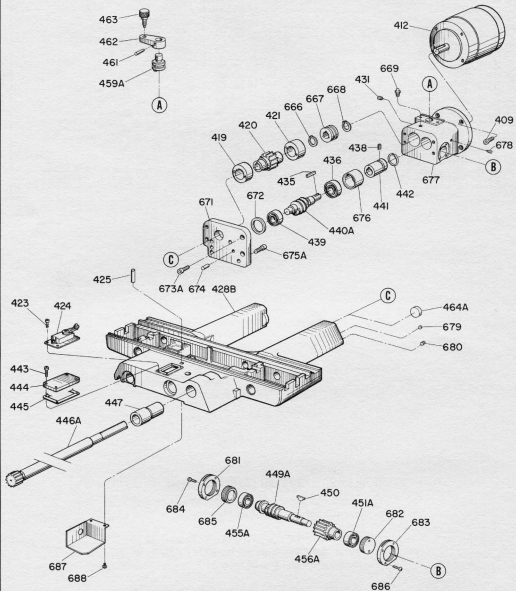

I23 KKK
I24 KKK

SADDLE TABLE - UNIT 1 DH (Continued)

KEY NO.	PART NO.	PART NAME	AMT. USED	KEY NO.	PART NO.	PART NAME	AMT. USED
1DH-409	3266	Screw	3	1DH-459A	191639	Shifter	1
1DH-412	*Example	Motor - 1/8 HP, 1140 RPM, Frame 44	1	1DH-461	663	Pin - Taper	1
1DH-419	126928	Bushing	1	1DH-462	126932	Lever - Shifter	1
1DH-420	159915	Wheel - Worm, Final Drive	1	1DH-463	112632	Screw - Reverse Lever	1
1DH-421	126928	Bushing	1	1DH-464A	3554	Plug (Without Power Feed)	1
1DH-423	2363	Screw	4	1DH-666	113079	Ring - Retaining	1
1DH-424	*249728	Switch - Limit	1	1DH-667	191617	Collar - Shifter	2
1DH-425	68205	Pin	1	1DH-668	113079	Ring - Retaining	1
1DH-428B	184634	Saddle - 24" Table Travel	1	1DH-669	3342	Fitting - Lubrication	1
1DH-431	3233	Screw	2	1DH-671	191624	Adapter - Housing, Power Feed	1
1DH-435	345	Key	1	1DH-672	191616	Spacer - Bearing	1
1DH-436	123795	Bearing - Ball	1	1DH-673A	3399	Screw	4
1DH-438	3228	Screw	1	1DH-674	3369	Pin	2
1DH-439	223632	Bearing - Ball	1	1DH-675A	3399	Screw	4
1DH-440A	191621	Shaft - Worm	1	1DH-676	191615	Retainer - Bearing	1
1DH-441	126933	Coupling	1	1DH-677	191625	Housing - Power Feed	1
1DH-442	30059	Ring - Spring	1	1DH-678	3229	Screw	1
1DH-443	3363	Screw (Without Power Feed)	4	1DH-679	2245	Plug (Without Power Feed)	2
1DH-444	159919	Cover - Limit Switch Opening (Without Power Feed)	1	1DH-680	1917	Screw (Without Power Feed)	4
1DH-445	159920	Gasket - Cover (Without Power Feed)	1	1DH-681	191619	Nut - Retainer	1
1DH-446A	191623	Shaft - Pinion	1	1DH-682	191618	Retainer - Bearing	1
1DH-447	126929	Bushing	1	1DH-683	191619	Nut - Retainer	1
1DH-448A	191622	Shaft - Worm	1	1DH-684	2371	Screw	4
1DH-450	3380	Key	1	1DH-685	191618	Retainer - Bearing	1
1DH-451A	261831	Bearing - Ball	1	1DH-686	2371	Screw	4
1DH-455A	261831	Bearing - Ball	1	1DH-687	193394	Cover - Switch	1
1DH-456A	191620	Wheel - Worm	1	1DH-688	2363	Screw	2

*When ordering replacement, give electrical requirements and the serial number of the machine.

CINCINNATI No. 2 CUTTER AND TOOL GRINDER

SADDLE-TABLE

BALL TRACK, TABLE HAND FEED, SPLASH GUARD 24" TABLE TRAVEL

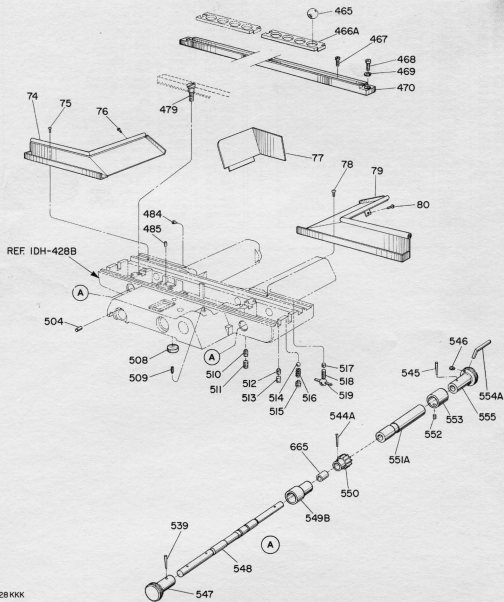

128 KKK
131 KKK

SADDLE TABLE—UNIT 1 DH (Continued)

KEY NO.	PART NO.	PART NAME	AMT. USED	KEY NO.	PART NO.	PART NAME	AMT. USED
1DP-74	191658	Guard - Splash, L. H.	1	1DH-514	13665	Ball - 5/16" Diameter	2
1DP-75	2368	Screw	1	1DH-515	3232	Screw	2
1DP-76	2375	Screw	1	1DH-516	262	Spring	2
1DP-77	193390	Guard - Splash, L. H. Rear	1	1DH-517	1962	Plug	2
1DP-78	2368	Screw	1	1DH-518	3536	Screw	2
1DP-79	191659	Guard - Splash, R. H.	1	1DH-519	3537	Handle	2
1DP-80	2375	Screw	1	1DH-539	642	Pin - Taper	2
1DH-465	68489	Ball - 3/4"	48	1DH-544A	148097	Pin - Taper	2
1DH-466A	184646	Cage - Ball	12	1DH-545	642	Pin - Taper	2
1DH-467	3396	Screw	20	1DH-546	1911	Screw	2
1DH-468	3400	Screw	4	1DH-547	129716	Knob - Shaft	2
1DH-469	2135	Washer	4	1DH-548	126815	Shaft - Hand Feed	2
1DH-470	159903	Track - Ball	2	1DH-549B	180232	Bushing - Front Hand Feed Shaft	2
1DH-479	140209	Stud - Safety	4	1DH-550	107411	Pinion	2
1DH-484	2209	Screw	1	1DH-551A	180233	Bushing - Rear Hand Feed Shaft	2
1DH-485	2251	Plug	2	1DH-552	3228	Screw	2
1DH-504	79860	Pin - Index	2	1DH-553	79962	Guard - Handwheel	2
1DH-508	3559	Plug - 3" Standard	1	1DH-554A	67947	Lever - Shaft Hand Feed	2
1DH-509	3233	Screw	1	1DH-555	130019	Knob - Shaft	2
1DH-510	3233	Screw	2	1DH-665	191653	Bushing - Ollite	2
1DH-511	3211	Screw	2				
1DH-512	1917	Screw	2				
1DH-513	3232	Screw	2				

CINCINNATI No. 2 CUTTER AND TOOL GRINDER

SADDLE TABLE

CROSSFEED, SLOW TABLE HAND FEED 16" AND 24" TABLE TRAVEL

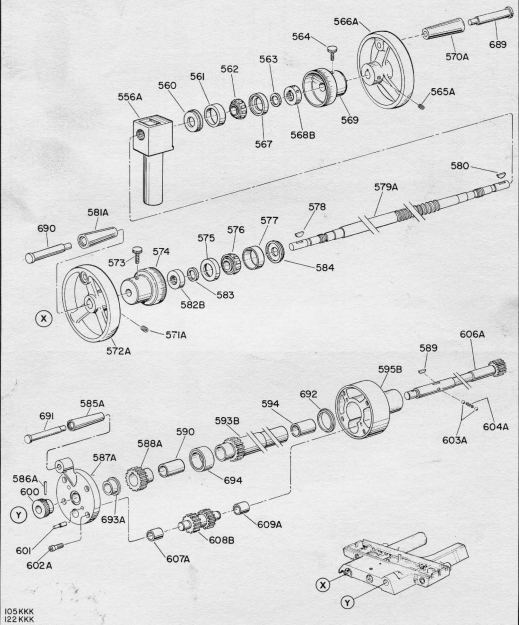

105 KKK
122 KKK

SADDLE TABLE—UNIT 1 DH (Continued)

KEY NO.	PART NO.	PART NAME	AMT. USED	KEY NO.	PART NO.	PART NAME	AMT. USED
1DH-556A		Nut - Crossfeed		1DH-560	3280	Key	1
	193336	Inch System	1	1DH-561A	187974	Handle	1
	193337	Metric	1	1DH-562B	4184	Nut - Lock	1
1DH-560	129704	Retainer - Grease	1	1DH-563	126829	Washer - Bearing	1
1DH-561	201806	Cup - Bearing	1	1DH-564	129704	Retainer - Grease	1
1DH-562	201811	Cone - Bearing	1	1DH-555A	187974	Handle	1
1DH-563	126829	Washer - Bearing	1	1DH-566A	143	Pin - Taper	1
1DH-564	77200	Screw - Thumb	1	1DH-567A	191609	Cover - Housing	1
1DH-565A	3234	Screw	1	1DH-568A	193378	Gear - Table	1
1DH-566A	188934	Handwheel	1	1DH-569	1266	Key	1
1DH-567	129703	Retainer - Grease	1	1DH-590	126847	Bushing - Oillite	1
1DH-568B	4184	Nut - Lock	1	1DH-593B	193377	Gear - Table Feed Sleeve	1
1DH-569		Dial - Crossfeed, Rear		1DH-594	126847	Bushing - Oillite	1
	129709	Inch System	1	1DH-595B	191612	Housing - Differential Gear	1
	130325	Metric	1	1DH-600	62498	Knob - On Table Feed Shaft	1
1DH-570A	187974	Handle	1	1DH-601	1421	Pin	1
1DH-571A	3234	Screw	1	1DH-602A	3399	Screw	4
1DH-572A	188934	Handwheel	1	1DH-603A	30060	Ball - Steel	2
1DH-573	77200	Screw - Thumb	1	1DH-604A	101732	Spring	1
1DH-574		Dial - Crossfeed, Front		1DH-605A	191607	Shaft - Long Table Feed	1
	129710	Inch System	1	1DH-607A	602122	Bushing	1
	130324	Metric	1	1DH-608B	193379	Gear - On Table Feed Stud	1
1DH-575	129703	Retainer - Grease	1	1DH-608A	602122	Bushing	1
1DH-576	201811	Cone - Bearing	1	1DH-689	187575	Stud	1
1DH-577	201806	Cup - Bearing	1	1DH-690	187575	Stud	1
1DH-578A	3280	Key	1	1DH-691	187575	Stud	1
1DH-579A		Screw - Crossfeed		1DH-692	191606	Spacer	1
	184625	Inch System	1	1DH-693A	304628	Bushing	1
	184626	Metric	1	1DH-694	137508	Bearing - Needle	1

TO REMOVE CROSS FEED SCREW (579A, RP20) AND NUT (556A, RP20) AND SADDLE (428B, RP16)

- Run saddle fully forward. Loosen set screw (565A, RP20), knurled thumb screw (564) and remove rear handwheel (566A), dial (569) and key (580). Loosen set screw in nut, tap screw to loosen lock shoe under it, and remove shoe type lock nut (568B). Using front handwheel (572A) turn left-hand cross feed screw clockwise out of saddle. Front bearing and seal will emerge with screw. Screw will be forced out of rear bearing cone.
- Place rope slings around ends of saddle and pick it up off the base with a crane.
- Remove two set screws (31, 32, RP30) from side of bed and tap cross feed nut (556A) up out of bed.

When assembling, allow cross feed nut to remain free until saddle and cross feed screw have been replaced and tested for freedom of movement before locking nut with the set screws. It is best to install a new screw and nut in case either shows wear.

The taper bearings on ends of cross feed screw should be so adjusted that handwheels have no more than .005" rotary play. The inner edge of dials must clear sides of saddle and cross screw should protrude an equal amount past handwheel hubs.

TO REMOVE TABLE FEED PINION SHAFT ASSEMBLY (606A, RP20)

Remove set screw (313, RP14 or 509, RP18) and pull shaft assembly out front of bed.

CINCINNATI No. 2 CUTTER AND TOOL GRINDER

SADDLE TABLE

SADDLE TABLE LUBRICATION

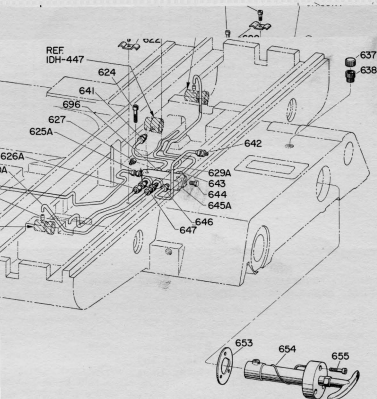

124 KKK

SADDLE TABLE-UNIT 1 DH (Continued)

KEY NO.	PART NO.	PART NAME	AMT. USED	KEY NO.	PART NO.	PART NAME	AMT. USED
1DH-620	320002	Clip - Tubing	1	1DH-642		Fitting	
1DH-621	3198	Screw	1	214300		Bushing - Compression	1
1DH-622	126912	Clip - Double, Tubing	2	214303		Adapter - Straight Type "F"	1
1DH-623	3198	Screw	2	214304		Sleeve - Compression	1
1DH-624	3227	Screw	2	1DH-643		Fitting	
1DH-625B		Fitting		214294		Nut - Compression	2
	214294	Nut - Compression	1	214304		Sleeve - Compression	2
	214304	Sleeve - Compression	1	220004		Plug - Drip #0	2
	220003	Plug - Drip #2	1	1DH-644	77411	Plug - Closure	1
1DH-626A		Fitting		1DH-645A	143766	Junction - Eight Way	1
	214294	Nut - Compression	1	1DH-646		Fitting	
	214304	Sleeve - Compression	1	214300		Bushing - Compression	1
	220003	Plug - Drip #2	1	214304		Sleeve - Compression	1
1DH-627	77411	Plug - Closure (Used Without Power Feed)	1	1DH-647		Fitting	
1DH-629A		Fitting		214294		Nut - Compression	2
	214294	Bushing - Compression	1	214304		Sleeve - Compression	2
	214304	Sleeve - Compression	1	220004		Plug - Drip #0	2
	220003	Plug - Drip #2	1	1DH-653	-----	Gasket - Supplied with Pump	1
1DH-630A	191852	Tubing - List	AR	1DH-654	129701	Pump - Lubricator	1
1DH-631A	77197	Bushing - Tube	2	1DH-655	3227	Screw	4
1DH-637	3986	Cap - Oil Filler	1	1DH-696		Fitting (With Power Feed Only)	
1DH-638	71937	Adapter - Filler Cap	1	214294		Nut - Compression	1
1DH-641		Fitting (With Power Feed Only)		214304		Sleeve - Compression	1
	214300	Bushing - Compression	1	77196		Plug - Drip #1	1
	214303	Adapter - Straight Type "F"	1				
	214304	Sleeve - Compression	1				

CINCINNATI No. 2 CUTTER AND TOOL GRINDER

SADDLE TABLE

TAILSTOCK - DIAMOND BRACKET

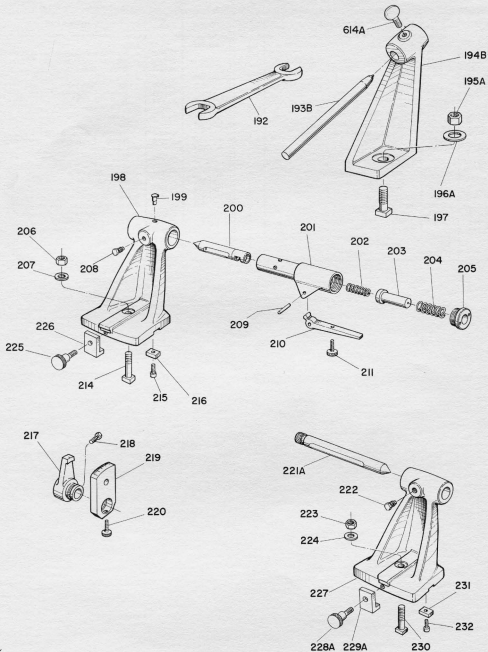

40KKK

SADDLE TABLE-UNIT 1 DH (Continued)

KEY NO.	PART NO.	PART NAME	AMT. USED	KEY NO.	PART NO.	PART NAME	AMT. USED
1DH-192	19476	Wrench (7/8 x 9/16)	1	1DH-212	59	Screw - Thumb	1
1DH-190B	195111	Nib - Diamond	1	1DH-214	3309	Bolt - Tee	1
1DH-194B	31381	Bracket - Diamond	1	1DH-215	3486	Screw	2
1DH-195A	3479	Nut	1	1DH-216	3312	Tongue	2
1DH-196A	3442	Washer	1	1DH-217	65470	Body - Clearance Setting	1
1DH-197	1745	Bolt - Tee	1	1DH-218	489	Screw	1
1DH-198	149571	Bracket - Tailstock, Right Hand	1	1DH-219	65471	Plate - Clearance Setting Dial	1
1DH-199	44980	Cup - Oil	1	1DH-220	2255	Screw - Thumb	1
1DH-200	143744	Center - Right Hand Tailstock	1	1DH-221A	64099	Center - Left Hand Tailstock	1
1DH-201	143746	Housing - Tailstock	1	1DH-222	143741	Screw - Lock	1
1DH-202	150021	Spring	1	1DH-223	3479	Nut	1
1DH-203	143749	Plunger - Spring	1	1DH-224	3442	Washer	1
1DH-204	143747	Spring	1	1DH-225	159914	Screw - Thumb	1
1DH-205	143748	Retainer - Cap	1	1DH-226	159913	Clamp - Workhead	1
1DH-206	3479	Nut	1	1DH-227	149572	Bracket - Tailstock, Left Hand	1
1DH-207	3442	Washer	1	1DH-228A	159914	Screw - Thumb	1
1DH-208	143741	Screw - Lock	1	1DH-228A	159913	Clamp - Workhead	1
1DH-209	3542	Pin - For Lever	1	1DH-230	3309	Bolt - Tee	1
1DH-210	143740	Lever - Tailstock	1	1DH-231	3312	Tongue	2
1DH-211	77200	Screw - Thumb	1	1DH-232	3486	Screw	2
				1DH-014A	62	Nut - Wing	1

CINCINNATI No. 2 CUTTER AND TOOL GRINDER

SADDLE TABLE

BLADE SUPPORTS

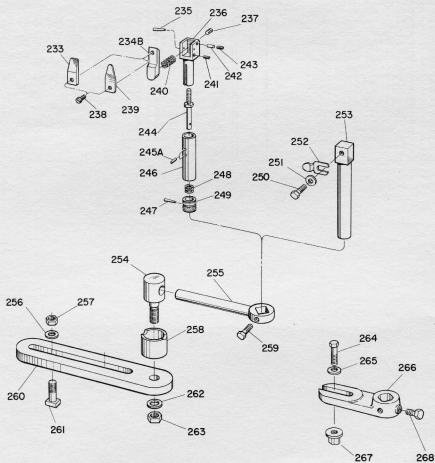

27KKK

SADDLE TABLE - UNIT 1 DH (Concluded)

KEY NO.	PART NO.	PART NAME	AMT. USED	KEY NO.	PART NO.	PART NAME	AMT. USED
1DH-233	64884	Blade - Square Top, 1/2" Wide	1	1DH-251	3441	Washer	1
1DH-234B	64899	Block - Swivel Blade Holder	1	1DH-252	65624	Blade - Plain Support	1
1DH-235	141	Pin - Taper	1	1DH-253	64903	Support - Blade, Plain	1
1DH-236	64901	Support - Blade, Adjustable	1	1DH-254	26243	Bolt - Eye, For Clamp	1
1DH-237	1879	Screw	1	1DH-255	31436	Extension	1
1DH-238	1650	Screw	1	1DH-256	3442	Washer	1
1DH-239	65657	Blade - Round Top	1	1DH-257	3479	Nut	1
1DH-240	727	Spring	1	1DH-258	23291	Ring - For Clamp	1
1DH-241	1205	Screw	1	1DH-259	489	Screw	1
1DH-242	1964	Plug	1	1DH-260	22884	Plate - Extension	1
1DH-243	2279	Screw	1	1DH-261	3311	Bolt - Tee	1
1DH-244	64897	Screw - Adjusting	1	1DH-262	3442	Washer	1
1DH-245A	193320	Pin	2	1DH-263	3479	Nut	1
1DH-246	67806	Sleeve - Blade Support	1	1DH-264	641	Screw	1
1DH-247	140	Pin - Taper	1	1DH-265	3441	Washer	1
1DH-248	253	Spring	1	1DH-266	66751	Block - Clamp	1
1DH-249	64900	Dial - Graduated	1	1DH-267	64906	Nut - Clamping	1
1DH-250	49	Screw	1	1DH-268	489	Screw	1

CINCINNATI No. 2 CUTTER AND TOOL GRINDER

WORKHEAD

WORKHEAD SPINDLE, DRAW-IN BOLT

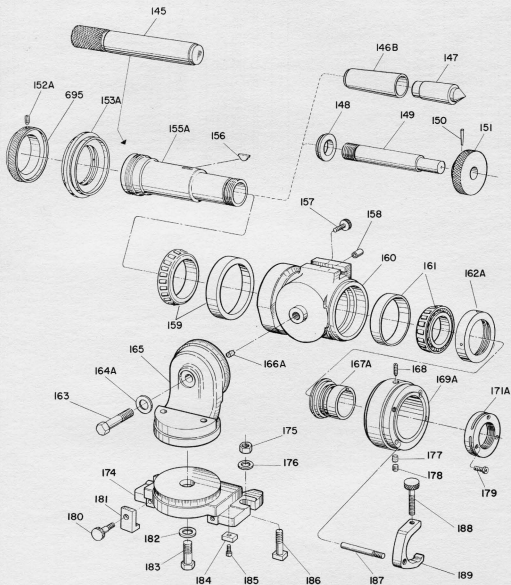

129 KKK

WORKHEAD - UNIT IDGC

KEY NO.	PART NO.	PART NAME	AMT. USED	KEY NO.	PART NO.	PART NAME	AMT. USED
IDGC-145	64854	Rod - Collet Extracting	1	IDGC-162A	191633	Ring - Dust (Small)	1
IDGC-146A	23052	Collet	1	IDGC-163	3427	Screw	1
	7487	12 to 7 B & S Taper	1	IDGC-164A	312	Washer	1
	7488	12 to 10 B & S Taper	1	IDGC-165	62561	Support - Workhead	1
	139687	#5 to #2 Morse Taper	1	IDGC-166A	178264	Plug	1
	139688	#5 to #3 Morse Taper	1	IDGC-167A	191634	Bushing - Cutter Dial	1
	139689	#5 to #4 Morse Taper	1	IDGC-168	3455	Screw	1
IDGC-147		Center	1	IDGC-169A	191636	Dial - Cutter Setting	1
	69049	12 B & S Taper	1	IDGC-171A	196473	Nut - Lock	1
	96789	#5 Morse Taper	1	IDGC-174	156160	Plate - Work	1
IDGC-148	62465	Collar - Draw In Bolt	1	IDGC-175	3479	Nut	2
IDGC-149	69047	Bolt - Draw In	1	IDGC-176	3442	Washer	2
IDGC-150	642	Pin - Taper	1	IDGC-177	1936	Plug	1
IDGC-151	62464	Knob - Draw In	1	IDGC-178	1215	Screw	1
IDGC-152A	3229	Screw	1	IDGC-179	3203	Screw	3
IDGC-153A	191635	Cap - Dust	1	IDGC-180	159914	Screw - Thumb	2
IDGC-155A		Spindle - Workhead	1	IDGC-181	159913	Clamp - Workhead	2
	191637	12 B & S Taper	1	IDGC-182	1940	Washer	1
	191669	#5 Morse Taper	1	IDGC-183	3428	Bolt	1
IDGC-156	3279	Key	1	IDGC-184	3312	Tongue	2
IDGC-157	87401	Screw - Thumb	1	IDGC-185	3488	Screw	2
IDGC-158	40553	Oiler	1	IDGC-186	3311	Bolt	2
IDGC-159	69045	Bearing	1	IDGC-187	62867	Pin - Dog Setting	1
IDGC-160	69042	Head - Work	1	IDGC-188	34896	Screw - Dog Setting	1
IDGC-161	69044	Bearing	1	IDGC-189	62856	Dog - Setting	1
				IDGC-695	191689	Cap - Drive, Workhead	1

TO REMOVE WORK HEAD SPINDLE (155A, RP28)

1. Remove lock nut (171A) from spindle and loosen set screw (168) in top of cutter setting dial. Slip cutter setting dial (169A) and bushing (167A) from rear of workhead.

Remove key (156). This should be a nice fit in both spindle and bushing.

2. Loosen knurled thumb screw (157), place draw in bolt (149) assembly back into workhead spindle (155A) and tap spindle forward out of workhead.

Examine the dust ring (162A) on workhead, dust cap (153A) and cutter setting dial (169A), and the drive cap (695) on spindle, for any evidence of rubbing. The clearance between these parts is very small and any mishandling or bumping while off will cause contact and aside from making it hard to rotate workhead, it may cause run out.

CINCINNATI No. 2 CUTTER AND TOOL GRINDER

BASE

BASE AND ELEVATING SHAFT



- 104 KKK
- 132 KKK
- 133 KKK
- 136 KKK
- 137 KKK
- 143 KKK
- 146 KKK

BASE-UNIT 1 DAB

KEY NO.	PART NO.	PART NAME	AMT. USED	KEY NO.	PART NO.	PART NAME	AMT. USED
IDAB-1	188934	Handwheel	1	IDNN-35		Plate - Electrical Direction	1
IDAB-2	77200	Screw - Thumb	1	170779		English	1
IDAB-3		Dial - Elevating, Left Hand	1	196480		Symbolized	1
	129740	Lock System	1	IDNN-36		Plate - Switch Mounting	1
	129759	Metric	1	IDAB-38	184637	Base	1
IDAB-4	110202	Nut - Lock	1	IDAB-39	936	Washer	4
IDAB-5	77264	Cone - Bearing	1	IDAB-40	3396	Screw - Cap	4
IDAB-6	72141	Cup - Bearing	1	IDM-41	Example	Cover - Blank, #DS-100 (If no conduit cover is used)	1
IDAB-7	191684	Adapter - Bearing, Left Side	1	IDN-42	143696	Screw - Self Tapping	4
IDAB-8	191693	Sleeve - Elevating Mechanism	1	IDM-43	141239	Cover - Conduit	1
IDAB-9	72141	Cup - Bearing	1	IDM-44	Example	Gasket - Neoprene #1014	1
IDAB-10	77264	Cone - Bearing	1	IDN-45	160010	Plate - Outlet Mounting	1
IDAB-11	187975	Stud	1	IDAB-47	3975	Louwer	2
IDAB-12	187974	Handle	1	IDNN-49	160005	Plate - Switch Mounting	1
IDAB-13	3498	Screw - Set	1	IDNN-50		Plate - Electrical Control	1
IDAB-14	3396	Screw - Cap	4	156230		English	1
IDAB-15	936	Washer	4	196481		Symbolized	1
IDAB-16	3280	Key	1	IDNN-50		Plate - Electrical Control	1
IDAB-17	191687	Shaft - Elevating Worm	1	IDNN-51	143696	Screw - Self Tapping	4
IDAB-18	3280	Key	1	IDN-52A	249387	Screw	2
IDAB-19	191692	Gear - Worm, Elevating	1	IDN-53A		Assembly - Door and Frame, Electrical Panel (Without Power Feed)	1
IDAB-20	663	Pin - Taper	1		304500	With or Without Coolant	1
IDAB-21	3404	Screw - Cap	5		304506	Grinding or End Mill Grinding Attachments	1
IDAB-22	191332	Cover - Base, Top	1	IDN-54A	2369	Screw - Self Tapping	8
IDAB-23	601526	Bushing - Ollite	1	IDNN-36		Screw - Self Tapping	1
IDAB-24	191696	Adapter - Bearing, Right Side	1	298745		Use with Plate 159997	8
IDAB-25		Dial - Elevating, Right Hand	1	2311		Use with Plate 173032	8
	129739	Lock System	1	IDNN-57		Plate - Electrical Direction	1
	129758	Metric	1	173032		With Power Feed	1
IDAB-26	77200	Screw - Thumb	1	196482		Symbolized	1
IDAB-27	3498	Screw - Set	1	159997		With or Without Coolant, With Radius Grinding or End Mill Grinding Attachments	1
IDAB-28	188934	Handwheel	1	308809		Symbolized	1
IDAB-29	187974	Handle	1	160024		Plate - Electrical Mounting (With Power Feed)	1
IDAB-30	187975	Stud	1				
IDAB-31	1910	Screw - Set	1				
IDAB-32	3243	Screw - Set	1				
IDAB-33	2209	Screw - Drive	1				
IDNN-34	2368	Screw - Button Head Cap	4				

TO REMOVE ELEVATING WORM SHAFT (17, RP30)

1. Take off louver (47, RP30) and tighten screw (81, RP32) to keep column from dropping when elevating shaft is removed.

After assembly, retighten clamping screw (81) only sufficiently so weight of sleeve and wheelhead will always cause rack (68) to rest on elevating pinion (79), thus, any possible backlash is always eliminated.

2. Loosen screws (26 and 27, RP30), remove handwheel and dial and lift out key (18) from right end of elevating shaft. Loosen set screw (73, RP32) holding sleeve (8, RP30).

Using left side handwheel rotate elevating shaft counterclockwise out of base. Items 1 through 20 will emerge together.

CINCINNATI No. 2 CUTTER AND TOOL GRINDER

BASE

COLUMN HOUSING & SLEEVE

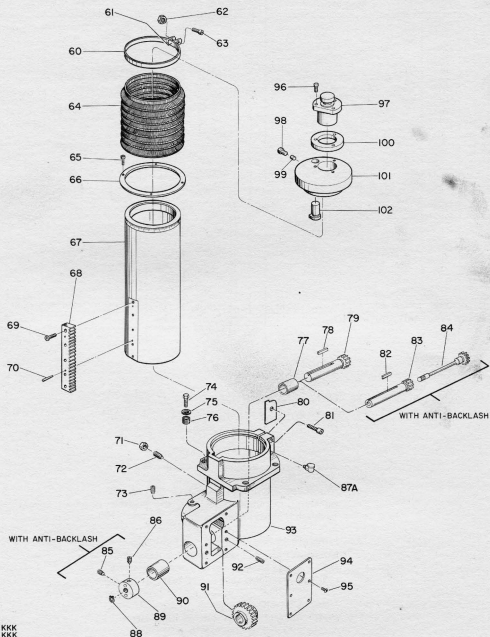

104 KKK
146 KKK

BASE-UNIT 1 DAB (Concluded)

KEY NO.	PART NO.	PART NAME	AMT. USED	KEY NO.	PART NO.	PART NAME	AMT. USED
IDAB-60	103261	Ring - Sleeve	1	IDAB-83	184608	Pinion - Rack, Elevating	
IDAB-61	105653	Plate - Sleeve Ring	1			(With Anti-Backlash)	1
IDAB-62	3477	Nut - Hex	1	IDAB-84	191843	Pinion - Anti-Backlash	
IDAB-63	3396	Screw - Cap	1			(With Anti-Backlash)	1
IDAB-64	103072	Guard - Dust	1	IDAB-85	700034	Screw - Set (With Anti-Backlash)	1
IDAB-65	2203	Screw - Cap	4	IDAB-86	700044	Screw - Set (With Anti-Backlash)	1
IDAB-66	103159	Ring - Housing	1	IDAB-87A	312351	Oiler	2
IDAB-67	154414	Sleeve - Column	1	IDAB-88	236956	Ring - Retaining (With Anti-Backlash)	1
IDAB-68	126797	Rack - Elevating	1	IDAB-89	191685	Cap - Adjusting (With Anti-Backlash)	1
IDAB-69	3209	Screw - Cap	5	IDAB-90	184607	Bearing - Sleeve, Oilite	1
IDAB-70	739	Pin - Taper	2	IDAB-91	184620	Wheel - Elevating Worm	1
IDAB-71	3474	Nut - Hex	1	IDAB-92	3238	Screw - Set	2
IDAB-72	3240	Screw - Set	1	IDAB-93	184619	Housing - Elevating	1
IDAB-73	250272	Screw - Set	1	IDAB-94	184621	Cover - Housing	1
IDAB-74	3463	Screw - Hex Head	4	IDAB-95	2369	Screw - Button Head Cap	6
IDAB-75	3442	Washer	4	IDAB-96	3399	Screw - Cap	3
IDAB-76	76386	Bushing - Adjusting	4	IDAB-97	189635	Trunnion	1
IDAB-77	184607	Bearing - Sleeve, Oilite	1	IDAB-98	741	Screw - Hex Head Set	1
IDAB-78	814	Key	1	IDAB-99	157037	Plug - Locking	1
IDAB-79	191697	Pinion - Rack, Elevating	1	IDAB-100	193371	Plate - Head Index	1
IDAB-80	64790	Gasket - Housing	1	IDAB-101	154413	Plate - Mounting	1
IDAB-81	1930	Screw - Cap	1	IDAB-102	154412	Clamp	1
IDAB-82	814	Key (With Anti-Backlash)	1				

TO REMOVE WHEELHEAD, (18A, RP4) COLUMN SLEEVE (67, RP32) AND HOUSING (93, RP32)

- Remove belt guard, grinding wheel guard and grinding wheel from wheelhead.
- Remove screw (156, RP4) and plug (157) from column sleeve (67, RP32). Place a rope sling around the wheelhead and lift it, with mounting plate (159, RP4) and tilting bracket (77) (if used), straight upward out of the column sleeve.
- Remove screw (48, RP4) and plug (47) from wheelhead housing (18A) and separate trunnion (155) from the wheelhead housing.
- Through bottom openings of base remove set screw (72, RP37) from left side of housing (93). (This set screw, riding in a groove of column sleeve, limits vertical movement of sleeve.) Raise sleeve to topmost position with elevating handwheel and remove four screws (65) that fasten dust guard to housing. Remove clamp ring (60) and lift off dust

guard (64). Loosen clamp screw (81). Affix an eyebolt to the center of a steel plate $\frac{1}{4}$ " x 1" x $6\frac{1}{2}$ ", lower plate into sleeve so it catches on inner lip, near top, and raise sleeve out of column.

- Proceed as per instructions on page RP31 and remove elevating worm shaft.

Remove four screws (74, RP32) from top of housing. Do not alter positions of bushings (76). Affix an eyebolt to the center of a steel plate ($\frac{1}{4}$ " x 1" x $9\frac{3}{4}$ "). Lower the plate into the housing at a 45° angle; then straighten plate until it catches on the lip inside the housing and raise the housing out of the base.

After assembly it will be necessary to tram spindle to table in various positions. If necessary, use adjusting bushings (76, RP32) to align spindle to table. Retram after hold-down screws (74) have been tightened.

When reassembling, eliminate backlash between rack (68, RP32) and elevating pinion (91) by tightening screw (81) so that the weight of the column sleeve and wheelhead maintains contact between the rack and pinion.

COOLANT PUMP AND PIPING

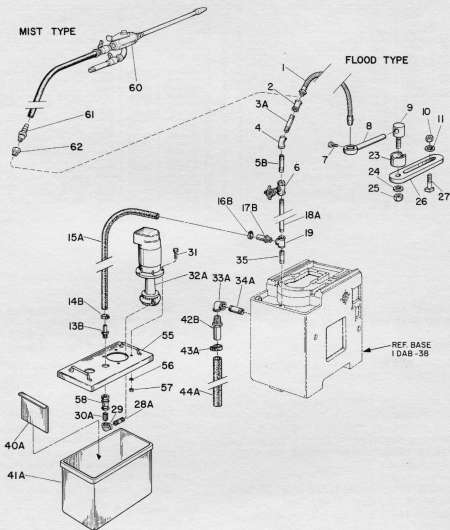

132 KKK
133 KKK
149 KKK

COOLANT PUMP AND PIPING - UNIT 1 DP

KEY NO.	PART NO.	PART NAME	AMT. USED	KEY NO.	PART NO.	PART NAME	AMT. USED
IDP-1	159945	*Hose - Coolant	1	IDP-27	3311	*Bolt - Tee	1
IDP-2	4065	Coupling - 3/8"	1	IDP-28A	-----	Pipe - 1/2" P. S. x 2" lg.	1
IDP-3A	-----	Pipe - 3/8" P. S. x 4" lg.	1	IDP-29	24806	Elbow - 1/2"	1
IDP-4	37571	Elbow - 3/8 x 45	1	IDP-30A	203424	Nipple	1
IDP-5B	205239	Nipple	1	IDP-31	3378	Screw	4
IDP-6	159944	Valve - Needle	1	IDP-32A	131046	Pump - Coolant	1
IDP-7	489	*Screw	1	IDP-33A	57483	Elbow - 1-1/4"	1
IDP-8	31436	*Support - Extension Blade Holder	1	IDP-34A	-----	Pipe - 1-1/4" P. S. x 5-1/2" lg.	1
IDP-9	26243	*Bolt - Eye for Clamp	1	IDP-35	159954	Support - Pipe	1
IDP-10	3479	*Nut	1	IDP-40A	191628	Baffle - Coolant Tank	1
IDP-11	3442	*Washer	1	IDP-41A	191626	Tank - Coolant	1
IDP-13B	289234	Nipple - Coolant, Hose	1	IDP-42B	289441	Nipple - Hose	1
IDP-14B	80486	Clamp - Hose	1	IDP-43A	237001	Clamp - Hose	2
IDP-15A	158161	Hose - Coolant	1	IDP-44A	191629	Hose - Drain	1
IDP-16B	80486	Clamp - Hose	1	IDP-55	191627	Cover - Coolant Tank	1
IDP-17B	143536	Nipple - Coolant, Hose	1	IDP-56	2123	Washer	4
IDP-18A	-----	Pipe - 3/8" P. S. x 17-1/2" lg.	1	IDP-57	3472	Nut	4
IDP-19	89970	Tee - 3/8"	1	IDP-58	211228	Valve - Check	1
IDP-23	23291	*Ring - For Clamp	1	IDP-60	309444	**Valve - Mist Coolant	1
IDP-24	3442	*Washer	1	IDP-61	289139	**Fitting - Hose, Coolant	1
IDP-25	3479	*Nut	1	IDP-62	273960	**Bushing - Reducing	1
IDP-26	22684	*Plate - Extension	1				

*Flood Type

**Mist Type

WORK BLADE GRINDING ATTACHMENT

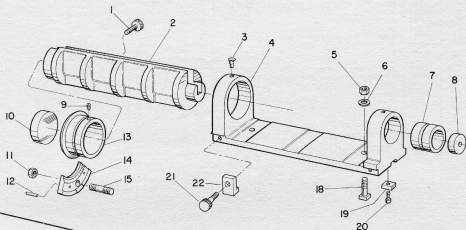

29 KKK

MICROMETER TABLE POSITIONING ATTACHMENT

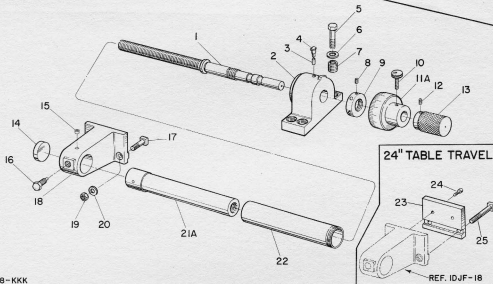

148-KKK

WORK BLADE GRINDING ATTACHMENT - UNIT 1DBW

KEY NO.	PART NO.	PART NAME	AMT. USED	KEY NO.	PART NO.	PART NAME	AMT. USED
1DBW-1	62999	Screw - Adjusting	3	1DBW-12	3544	Pin	2
1DBW-2	107501	Holder - Blade	1	1DBW-13	63002	Dial	1
1DBW-3	44980	Oiler - 5/16"	2	1DBW-14	63001	Block - Clamping	1
1DBW-4	107502	Body - Blade Grinding	1	1DBW-15	63000	Stud	1
1DBW-5	3479	Nut	2	1DBW-18	3515	Bolt - Tee	2
1DBW-7	62998	Bushing	1	1DBW-19	63006	Tongue	2
1DBW-6	3255	Plug	1	1DBW-20	3486	Screw	2
1DBW-9	3488	Screw	1	1DBW-21	159914	Screw - 24" Table	2
1DBW-10	3559	Plug	1	1DBW-22	159913	Clamp - Workhead, 24" Table	2
1DBW-11	3479	Nut	1				

MICROMETER TABLE POSITIONING ATTACHMENT - UNIT 1DJF

KEY NO.	PART NO.	PART NAME	AMT. USED	KEY NO.	PART NO.	PART NAME	AMT. USED
1DJF-1		Screw - Lead		1DJF-14	193357	Plug	1
	120714	Inch System	1	1DJF-15	60583	Oiler - 5/16"	1
	158545	Metric	1	1DJF-16	143741	Screw	1
1DJF-2	120715	Bracket - Screw	1	1DJF-17	3314	Bolt - Tee	2
1DJF-3	1936	Plug - Felt	1	1DJF-18	193354	Bracket - Nut	1
1DJF-4	44980	Oiler - 5/16"	1	1DJF-19	3478	Nut	2
1DJF-5	1062	Screw	4	1DJF-20	3461	Washer	2
1DJF-6	120717	Washer	4	1DJF-21		Nut - Leadscrew	
1DJF-7	120716	Bushing - Adjusting	4		193355	Inch System	1
1DJF-8	1911	Screw	1		193356	Metric	1
1DJF-9	4184	Nut - Lock	1	1DJF-22	134513	Tubing - Telescope	1
1DJF-10	2253	Screw - Thumb	1			24" TABLE TRAVEL ONLY	
1DJF-11A		Dial - Leadscrew					
	134512	Inch System	1				
	158547	Metric	1	1DJF-23	170782	Plate - Raising	1
1DJF-12	2332	Screw	1	1DJF-24	3396	Screw	2
1DJF-13	120713	Knob - On Screw	1	1DJF-25	109425	Bolt - Tee	2

CYLINDRICAL GRINDING ATTACHMENT—UNIT 1 DBT

KEY NO.	PART NO.	PART NAME	AMT. USED	KEY NO.	PART NO.	PART NAME	AMT. USED
IDBT-1		Flange - 4" For 4 Jaw Chuck		IDBT-17	2196	Washer - Lock	4
	160040	#12 B & S Taper	1	IDBT-18	3266	Screw	2
	160039	#5 Morse Taper	1	IDBT-19	3442	Washer	1
IDBT-2	160038	Chuck - 4" - 4 Jaw	1	IDBT-20	849	Screw	1
IDBT-2A	2324	Screw	4	IDBT-21		Screw	1
IDBT-3		Flange - For 3 Jaw Chuck (Standard)			2282	Standard - For 1/2" Hole Pulley	1
	157770	#12 B & S Taper	1		1879	For 5/8" Hole Grooved Pulley	1
	157769	#5 Morse Taper	1	IDBT-22		Pulley - Motor	
IDBT-4	157768	Chuck - 4" - 3 Jaw (Standard)	1		8436	Standard - 1/2" Hole	1
IDM-5	100611	Motor - Workhead, 1/4 HP, 1800/1500 RPM, 50/60 Cycle	1		109996	Grooved - 5/8" Hole	1
IDBT-6	107469	Pulley - Workhead	1	IDBT-23	62469	Belt - Workhead, Driving	1
IDBT-7	62455	Clamp - Workhead Pulley	2	IDBT-24	62462	Spacer - Carrier Dog	1
IDBT-8	2102	Screw	2	IDBT-25	7494	Dog - Carrier	1
IDBT-9	26147	Dog - Balance	1	IDBT-26	3464	Screw	1
IDBT-10A	184679	Plate - Motor (56 Frame Motor)	1	IDBT-27		Stem - Saw Grinding Attachment	1
IDBT-11	3442	Washer	1		38910	#12 B & S Taper	1
IDBT-12	849	Screw	1		96790	#5 Morse Taper	1
IDBT-13A	1679	Screw	2	IDBT-28	38911	Plate - Saw Grinding	1
IDBT-14	157064	Plate - Motor (48 Frame Motor)	1	IDBT-29	12	Screw	3
IDBT-15	157065	Plate - Motor Support (48 Frame Motor)	1	IDBT-30	7366	Bushing - Saw Grinding	1
IDBT-16	103317	Screw	4	IDBT-31	310	Screw	1
				IDBT-32	2321	Screw	6

DRAW-IN BOLT FOR COLLETS—UNIT 1 DJF

KEY NO.	PART NO.	PART NAME	AMT. USED	KEY NO.	PART NO.	PART NAME	AMT. USED
IDJF-35	139693	Collet - 50 to 40 N.S.	1	IDJF-37	642	Pin	1
IDJF-36	139694	Bolt - Draw In, For 50 to 40 N.S.	1	IDJF-38	62462	Knob - Draw In Bolt, For 50 to 40 N.S.	1

CINCINNATI No. 2 CUTTER AND TOOL GRINDER

HEAVY DUTY TAILSTOCK

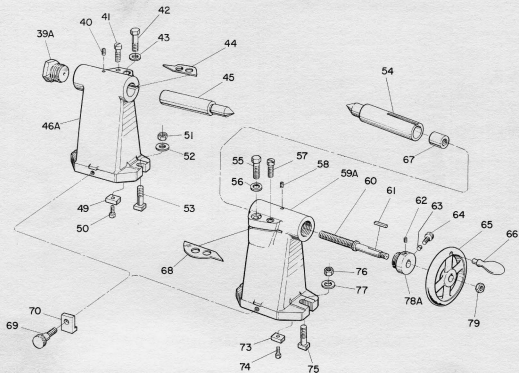

38096

DUST EXHAUST

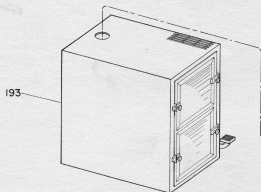

318248
318249

ACCESSORIES

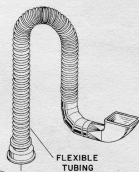

HEAVY DUTY TAILSTOCK ATTACHMENT - UNIT 1 DJF

KEY NO.	PART NO.	PART NAME	AMT. USED	KEY NO.	PART NO.	PART NAME	AMT. USED
1DJF-39A	305209	Cap - Tailstock, Left Hand	1	1DJF-60	20466	Screw - Spindle	1
1DJF-40	216	Screw	1	1DJF-61	864	Key	1
1DJF-41	1278	Screw	1	1DJF-62	1205	Screw	1
1DJF-42	635	Screw	1	1DJF-63	2008	Plug	1
1DJF-43	1035	Washer	1	1DJF-64	3193	Screw - Thumb	1
1DJF-44	37694	Packing	1	1DJF-65	20467	Handwheel	1
1DJF-45	135963	Spindle - Tailstock, Left Hand	1	1DJF-66	6809	Handle	1
1DJF-46A	305331	Body - Tailstock, Left Hand,	1	1DJF-67	8115	Nut - Spindle	1
		Dead Center	1	1DJF-68	37694	Packing	1
1DJF-49	3312	Tongue	2	1DJF-69	159914	Screw	2
1DJF-50	3486	Screw	2	1DJF-70	159913	Clamp - Workhead	2
1DJF-51	3479	Nut	2	1DJF-73	3312	Tongue	2
1DJF-52	3442	Washer	2	1DJF-74	3486	Screw	2
1DJF-53	3274	Bolt - Tee	2	1DJF-75	3274	Bolt - Tee	2
1DJF-54	8118	Spindle - Tailstock, Right Hand	1	1DJF-76	3479	Nut	2
1DJF-55	635	Screw	1	1DJF-77	3442	Washer	2
1DJF-56	1035	Washer	1	1DJF-78A	305208	Cap - Tailstock, Right Hand	1
1DJF-57	1278	Screw	1	1DJF-78	150	Nut	1
1DJF-58	216	Screw	1				
1DJF-59A	305331	Body - Tailstock, Right Hand,	1				
		Adjusting Center	1				

EXHAUST DUST ATTACHMENT - UNIT 1 DJF

KEY NO.	PART NO.	PART NAME	AMT. USED			
*1DJF-193	181982	Dust - Collector	1			

*318248 Model 64 - 3/4 hp
318249 Model 66 - 1/2 hp

ATTACHMENTS

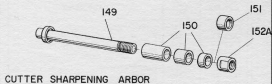

CUTTER SHARPENING ARBOR

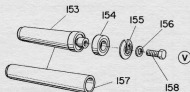

SAW SHARPENING & SIDE MILL

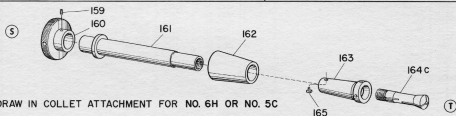

DRAW IN COLLET ATTACHMENT FOR NO. 6H OR NO. 5C

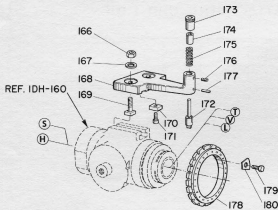

24 SLOT INDEXING ATTACHMENT

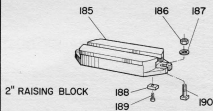

2" RAISING BLOCK



REDUCING COLLET

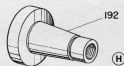

FACE MILL ADAPTER

ATTACHMENTS (Miscellaneous) - UNIT 1 DJF

KEY NO.	PART NO.	PART NAME	AMT. USED	KEY NO.	PART NO.	PART NAME	AMT. USED
1DJF-149		Arbor - Cutter Sharpening		186646-11	11/64" Hole	1	
	134519	7/8" Diameter x 8-3/16" Long	1	186646-12	3/16" Hole	1	
	134520	1" Diameter x 8-3/16" Long	1	186646-13	13/64" Hole	1	
	134521	1-1/4" Diameter x 8-3/4" Long	1	186646-14	7/32" Hole	1	
	134522	1-1/2" Diameter x 8-3/4" Long	1	186646-15	15/64" Hole	1	
	134523	2" Diameter x 8-3/4" Long	1	186646-16	1/4" Hole	1	
1DJF-150		Collar - Spacing, For 7/8" Diameter		186646-17	17/64" Hole	1	
		Arbor		186646-18	9/32" Hole	1	
	3646	2" Long	3	186646-19	19/64" Hole	1	
	3645	1" Long	2	186646-20	5/16" Hole	1	
	3644	1/2" Long	1	186646-21	21/64" Hole	1	
		Collar - Spacing, For 1" Diameter		186646-22	11/32" Hole	1	
		Arbor		186646-23	23/64" Hole	1	
	3649	2" Long	3	186646-24	3/8" Hole	1	
	3648	1" Long	2	186646-25	25/64" Hole	1	
	3647	1/2" Long	1	186646-26	13/32" Hole	1	
		Collar - Spacing, For 1-1/4" Diameter		186646-27	27/64" Hole	1	
		Arbor		186646-28	7/16" Hole	1	
	3653	2" Long	3	186646-29	29/64" Hole	1	
	3652	1" Long	2	186646-30	15/32" Hole	1	
	3651	1/2" Long	1	186646-31	31/64" Hole	1	
		Collar - Spacing, For 1-1/2" Diameter		186646-32	1/2" Hole	1	
		Arbor		186646-33	33/64" Hole	1	
	3657	2" Long	3	186646-34	17/32" Hole	1	
	3656	1" Long	2	186646-35	35/64" Hole	1	
	3655	1/2" Long	1	186646-36	9/16" Hole	1	
		Collar - Spacing, For 2" Diameter		186646-37	37/64" Hole	1	
		Arbor		186646-38	19/32" Hole	1	
	3661	2" Long	3	186646-39	39/64" Hole	1	
	3660	1" Long	2	186646-40	5/8" Hole	1	
	3659	1/2" Long	1	186646-41	41/64" Hole	1	
1DJF-151		Collar - Frost		186646-42	21/32" Hole	1	
	3677	For 1-1/4" Diameter Arbor	1	186646-43	43/64" Hole	1	
	3678	For 1-1/2" Diameter Arbor	1	186646-44	11/16" Hole	1	
	3679	For 2" Diameter Arbor	1	186646-45	45/64" Hole	1	
1DJF-152A		Nut - Arbor		186646-46	23/32" Hole	1	
	1341	For 7/8" Diameter Arbor	1	186646-47	47/64" Hole	1	
	3683	For 1" Diameter Arbor	1	186646-48	3/4" Hole	1	
	3682	For 1-1/4" Diameter Arbor	1	186646-49	49/64" Hole	1	
	3694	For 1-1/2" Diameter Arbor	1	186646-50	25/32" Hole	1	
	3694	For 2" Diameter Arbor	1	186646-51	51/64" Hole	1	
1DJF-153		Stem - For Sharpening Saw		186646-52	13/16" Hole	1	
	66801	#12 B & S Taper	1	186646-53	53/64" Hole	1	
	96791	#5 Morse Taper	1	186646-54	27/32" Hole	1	
1DJF-154	66800	Collar - For Saw	1	186646-55	55/64" Hole	1	
1DJF-155	66799	Collar - For Clamp Saw	1	186646-56	7/8" Hole	1	
1DJF-156	3441	Washer	1	186646-57	57/64" Hole	1	
1DJF-157	16033	Collet - On Collar	1	186646-58	29/32" Hole	1	
1DJF-158	49	Screw	1	186646-59	59/64" Hole	1	
1DJF-159	1879	Screw	1	186646-60	15/16" Hole	1	
1DJF-160	139877	Wheel - Hand	1	186646-61	61/64" Hole	1	
1DJF-161	139676	Bar - Draw In (For #6 H)	1	186646-62	31/32" Hole	1	
1DJF-162	165276	Bar - Draw In (For #5 C Collets)	1	186646-63	63/64" Hole	1	
1DJF-162	139678	Sleeve - Centering	1	186646-64	1" Hole	1	
1DJF-163		Collet - Adapter		186646-65	1-1/64" Hole	1	
	139880	#12 B & S Taper (For #6 H)	1	186646-66	1-1/32" Hole	1	
	139881	#5 Morse Taper (For #6 H)	1	186646-67	1-3/64" Hole	1	
	165272	#12 B & S Taper (For #5C)	1	186646-68	1-1/16" Hole	1	
	165271	#5 Morse Taper (For #5C)	1	186646-69	1-5/64" Hole	1	
1DNF-164C		Collet - #6 H		186646-70	1-3/32" Hole	1	
	186646-8	1/8" Hole	1	186646-71	1-7/64" Hole	1	
	186646-9	9/64" Hole	1	186646-72	1-1/8" Hole	1	
	186646-10	5/32" Hole	1				

NOTE: Key numbers 159 through 165 may be ordered as Chuck Adapter Assembly No. #5KKK. Specify collets desired (#6 H or 5 C).

CINCINNATI No. 2 CUTTER AND TOOL GRINDER

ATTACHMENTS

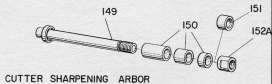

CUTTER SHARPENING ARBOR

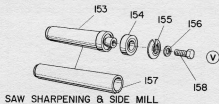

SAW SHARPENING & SIDE MILL

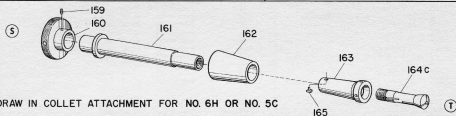

DRAW IN COLLET ATTACHMENT FOR NO. 6H OR NO. 5C

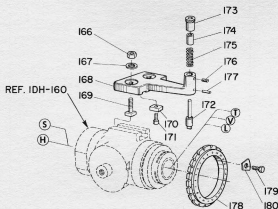

24 SLOT INDEXING ATTACHMENT

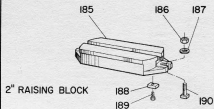

2" RAISING BLOCK



REDUCING COLLET

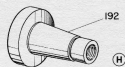

FACE MILL ADAPTER

ATTACHMENTS (Miscellaneous) - UNIT 1 DJF

KEY NO.	PART NO.	PART NAME	AMT. USED	KEY NO.	PART NO.	PART NAME	AMT. USED
1DJF-164C (Cont.)		Collet - Spring, #5C					
	186647-8	1/8" Hole	1		186647-38	15/32" Hole	1
	186647-9	9/64" Hole	1		186647-39	39/64" Hole	1
	186647-10	5/32" Hole	1		186647-40	5/8" Hole	1
	186647-11	11/64" Hole	1		186647-41	41/64" Hole	1
	186647-12	3/16" Hole	1		186647-42	21/32" Hole	1
	186647-13	13/64" Hole	1		186647-43	43/64" Hole	1
	186647-14	7/32" Hole	1		186647-44	11/16" Hole	1
	186647-15	15/64" Hole	1		186647-45	45/64" Hole	1
	186647-16	1/4" Hole	1		186647-46	23/32" Hole	1
	186647-17	17/64" Hole	1		186647-47	47/64" Hole	1
	186647-18	9/32" Hole	1		186647-48	3/4" Hole	1
	186647-19	19/64" Hole	1		186647-49	49/64" Hole	1
	186647-20	5/16" Hole	1		186647-50	25/32" Hole	1
	186647-21	21/64" Hole	1		186647-51	51/64" Hole	1
	186647-22	11/32" Hole	1		186647-52	13/64" Hole	1
	186647-23	23/64" Hole	1		186647-53	53/64" Hole	1
	186647-24	3/8" Hole	1		186647-54	27/32" Hole	1
	186647-25	25/64" Hole	1		186647-55	55/64" Hole	1
	186647-26	13/32" Hole	1		186647-56	7/8" Hole	1
	186647-27	27/64" Hole	1		186647-57	57/64" Hole	1
	186647-28	7/16" Hole	1		186647-58	29/32" Hole	1
	186647-29	29/64" Hole	1		186647-59	59/64" Hole	1
	186647-30	15/32" Hole	1		186647-60	15/16" Hole	1
	186647-31	31/64" Hole	1		186647-61	61/64" Hole	1
	186647-32	1/2" Hole	1		186647-62	31/32" Hole	1
	186647-33	33/64" Hole	1		186647-63	63/64" Hole	1
	186647-34	17/32" Hole	1		186647-64	1" Hole	1
	186647-35	35/64" Hole	1	1DJF-165	Key - In Collet		
	186647-36	8/16" Hole	1		139879	#6 H	1
	186647-37	37/64" Hole	1		85273	#5C	1

*NOTE: Key numbers 159 through 165 may be ordered as Chuck Adapter Assembly No. 65KKK. Specify collets desired (#H or #C).

CINCINNATI No. 2 CUTTER AND TOOL GRINDER

ATTACHMENTS

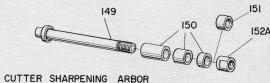

CUTTER SHARPENING ARBOR

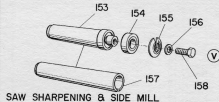

SAW SHARPENING & SIDE MILL

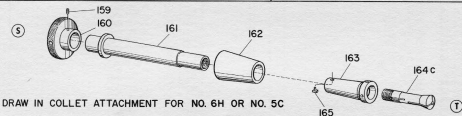

DRAW IN COLLET ATTACHMENT FOR NO. 6H OR NO. 5C

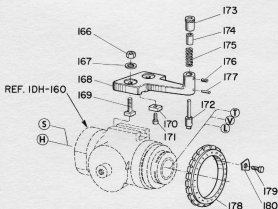

24 SLOT INDEXING ATTACHMENT

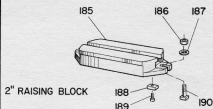

2" RAISING BLOCK



REDUCING COLLET

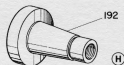

FACE MILL ADAPTER

ATTACHMENTS (Miscellaneous) - UNIT 1 DJF

KEY NO.	PART NO.	PART NAME	AMT. USED	KEY NO.	PART NO.	PART NAME	AMT. USED
1DJF-166	3479	Nut	1	1DJF-191		Collet - Reducing	
1DJF-167	3642	Washer	1		139690	#12 B & S to #1 Morse	1
1DJF-168	180205	Bracket - Index Pin	1		139691	#12 B & S to #2 Morse	1
1DJF-169	3274	Bolt - Tee	1		139692	#12 B & S to #3 Morse	1
1DJF-170	3312	Tongue	2		85862	#12 B & S to #4 Morse	1
1DJF-171	3486	Screw	2		146029	#12 B & S to #4 B & S	1
1DJF-172	103126	Pin - Index Lock	1		146030	#12 B & S to #5 B & S	1
1DJF-173	103129	Knob - Index Pin	1		146031	#12 B & S to #6 B & S	1
1DJF-174	103127	Bushing - Index Lock	1		146032	#12 B & S to #6 B & S	1
1DJF-175	253	Spring	1		16033	#12 B & S to #11 B & S	1
1DJF-176	2341	Screw - Set, In Index Bracket	1		146033	#5 Morse to #1 Morse	1
1DJF-177	2160	Pin	1		146034	#5 Morse to #4 B & S	1
1DJF-178	138647	Plate - Index 24 Slots	1		146035	#5 Morse to #5 B & S	1
1DJF-179	2103	Screw	1		146036	#5 Morse to #6 B & S	1
1DJF-180	62455	Clamp - Workhead	1		146037	#5 Morse to #7 B & S	1
1DJF-185	68663	Block - Raising 2"	1		146038	#5 Morse to #8 B & S	1
1DJF-186	3479	Nut	2		146039	#5 Morse to #9 B & S	1
1DJF-187	3442	Washer	2	146040	#5 Morse to #10 B & S	1	
1DJF-188	3312	Tongue	2	146041	#5 Morse to #11 B & S	1	
1DJF-189	3486	Screw	2	1DJF-192	117312	Adapter - Face Mill	1
1DJF-190	3311	Bolt - Tee	2				

GEAR CUTTER SHARPENING ATTACHMENT

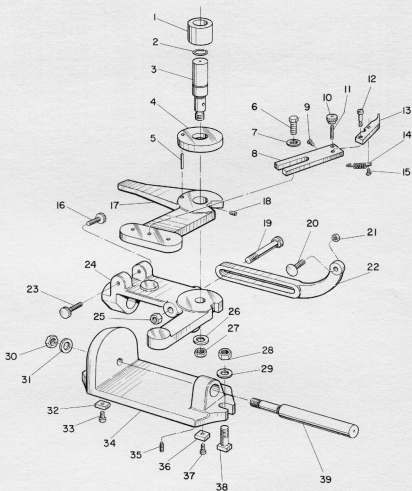

26KKK

GEAR CUTTER SHARPENING ATTACHMENTS—UNIT 1 DBV

KEY NO.	PART NO.	PART NAME	AMT. USED	KEY NO.	PART NO.	PART NAME	AMT. USED
1DBV-1		Bushing - Cutter		1DBV-15	3459	Screw	1
	62513	2" Diameter, English	1	1DBV-16	62522	Screw - Thumb Adjusting	1
	62512	1-3/4" Diameter, English	1	1DBV-17	62540	Plate - Cutter Supporting	1
	62511	1-1/2" Diameter, English	1	1DBV-18	1879	Screw	1
	62510	1-1/4" Diameter, English	1	1DBV-19	64960	Bolt - Centering Gage	1
	62509	1" Diameter, English	1	1DBV-20	66796	Pin - Centering Gage	1
	147973	50mm Diameter, Metric	1	1DBV-21	664	Nut	1
	62518	45mm Diameter, Metric	1	1DBV-22	120005	Bracket - Centering Gage	1
	62517	40mm Diameter, Metric	1	1DBV-23	62522	Screw - Thumb Adjusting	1
	62516	32mm Diameter, Metric	1	1DBV-24	64957	Bracket - Center	1
	62515	27mm Diameter, Metric	1	1DBV-25	3479	Nut	1
1DBV-2	71090	Ring - Spring Locking	1	1DBV-26	3442	Washer	1
1DBV-3		Stud - Cutter		1DBV-27	3474	Nut	1
	62507	7/8" Diameter, English	1	1DBV-28	3479	Nut	2
	62514	25mm Diameter, Metric	1	1DBV-29	3442	Washer	2
1DBV-4	64958	Collar - Cutter, Stud	1	1DBV-30	506	Nut	1
1DBV-5	3542	Pin	1	1DBV-31	888	Washer	1
1DBV-6	641	Screw	1	1DBV-32	3312	Tongue	1
1DBV-7	3441	Washer	1	1DBV-33	3486	Screw	1
1DBV-8	67496	Holder - Pawl	1	1DBV-34	62560	Base - Gear Cutter Grinder	1
1DBV-9	3459	Screw	1	1DBV-35	3454	Screw	1
1DBV-10	67495	Knob - Holder Stud	1	1DBV-36	3312	Tongue	1
1DBV-11	67494	Stud - Holder	1	1DBV-37	3486	Screw	1
1DBV-12	62521	Screw - Phillips Head	1	1DBV-38	3311	Bolt - Tee	2
1DBV-13	67497	Pawl	1	1DBV-39	118448	Shaft - Rocker	1
1DBV-14	251	Spring	1				

CINCINNATI No. 2 CUTTER AND TOOL GRINDER

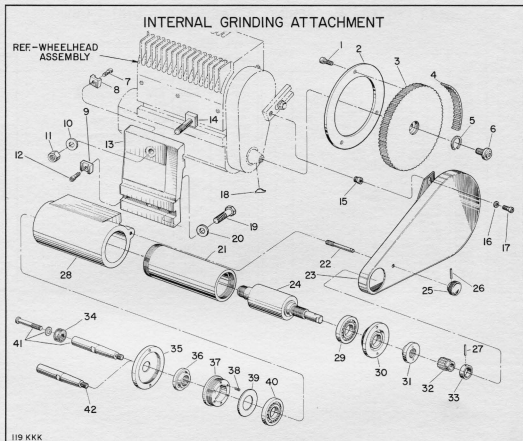

119 KKK

WITHOUT TILTING WHEELHEAD

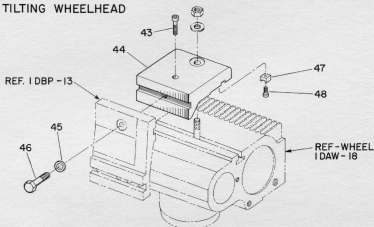

121 KKK

INTERNAL GRINDING ATTACHMENT - UNIT 1 DBP

KEY NO.	PART NO.	PART NAME	AMT. USED	KEY NO.	PART NO.	PART NAME	AMT. USED
IDBP-1	3199	Screw - Cap	3	IDBP-27	148454	Pin	1
IDBP-2	148465	Flange - Driver	1	IDBP-28	170505	Body	1
IDBP-3	148464	Pulley - Driver	1	IDBP-29	148457	Bearing - Ball	1
IDBP-4	186583	Belt - Timing	1	IDBP-30	148529	Nut - Retainer	1
IDBP-5	188711	Ring - Retaining	1	IDBP-31	148519	Nut - Retainer	1
IDBP-6	143627	Screw	1	IDBP-32	148453	Pulley - Driver	1
IDBP-7	3218	Screw - Cap	2	IDBP-33	148452	Flange - Driven	1
IDBP-8	3312	Tongue	2	IDBP-34		Wheel - Grinding	1
IDBP-9	3312	Tongue	2		158178	5/8 x 1/2 x 1/4 Hole - Straight, B/PIY	1
IDBP-10	3442	Washer	1		158179	3/4 x 1/2 x 1/4 Hole - Straight, B/PIY	1
IDBP-11	3479	Nut - Hex	1		158180	1 x 1/2 x 1/4 Hole - Straight, B/PIY	1
IDBP-12	3218	Screw - Cap	2			Cap - Dust	1
IDBP-13	170506	Bracket - Support	1	IDBP-35	148456	Nut - Retainer	1
IDBP-14	3311	Bolt - Tee	1	IDBP-36	148461	Nut - Retainer, Outer	1
IDBP-15		Spacer - Belt Guard	1	IDBP-37	148610	Spring - Loading	6
	189643	Front	1	IDBP-38	156134	Ring - Loading	1
	189644	Rear (Shown)	1	IDBP-39	148509	Bearing - Ball	1
IDBP-16	936	Washer	1	IDBP-40	148457	Quill - Type 1, 3/8 Hole	1
IDBP-17	3386	Screw - Cap	1	IDBP-41	148463	Quill - Type 2, 1/4 Hole	1
IDBP-18	3279	Key	1	IDBP-42	158177	Screw - Cap	1
IDBP-19	3463	Screw - Hex Head	1	IDBP-43	3397	Bracket - Adapter	1
IDBP-20	3442	Washer	1	IDBP-44	189679	Washer	1
IDBP-21	148472	Sleeve - Spindle	1	IDBP-45	3442	Screw - Hex Head	1
IDBP-22	143622	Stud - Cover	1	IDBP-46	3463	Screw - Hex Head	1
IDBP-23	173020	Guard - Belt	1	IDBP-47	3312	Tongue	2
IDBP-24	150042	Spindle	1	IDBP-48	3218	Screw - Cap	2
IDBP-25	128873	Knob	1				
IDBP-26	140	Pin - Taper	1				

CINCINNATI No. 2 CUTTER AND TOOL GRINDER

NO.1 RADIUS GRINDING ATTACHMENT

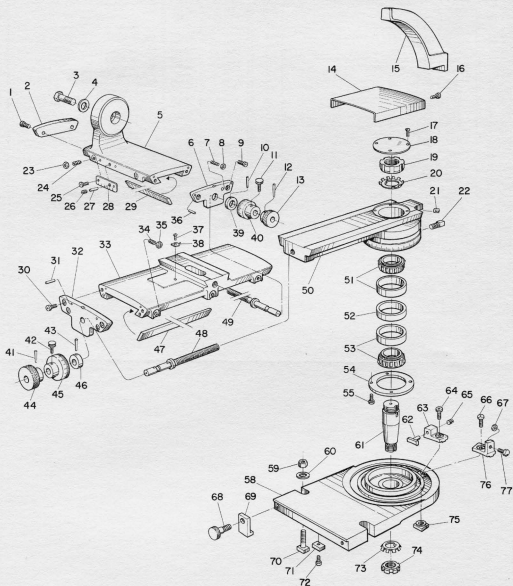

18KKK

RADIUS GRINDING ATTACHMENT - NO. 1 - UNIT 1 DGB

KEY NO.	PART NO.	PART NAME	AMT. USED	KEY NO.	PART NO.	PART NAME	AMT. USED
IDGB-1	3203	Screw	2	IDGB-40		Dial - Cross Screw	
IDGB-2	103108	Cover - Workhead Support	1	103114		Inch System	1
IDGB-3	183	Screw	1	115107		Metric	1
IDGB-4	1040	Washer	1	IDGB-41	2291	Pin	1
IDGB-5	112570	Support - Workhead	1	IDGB-42	2253	Screw - Thumb	1
IDGB-6	103109	Apron - Workhead Support	1	IDGB-43	2291	Pin	1
IDGB-7	3231	Screw	1	IDGB-44	103106	Knob - Longitudinal Screw	1
IDGB-8	3472	Nut	1	IDGB-45		Dial - Longitudinal Screw	
IDGB-9	3204	Screw	2	103105		Inch System	1
IDGB-10	2291	Pin	1	115108		Metric	1
IDGB-11	3196	Screw - Thumb	1	103103		Collar - Screw	1
IDGB-12	2291	Pin	1	IDGB-47	103101	Gib - Slide	1
IDGB-13	103115	Knob - Cross	1	IDGB-48	103102	Screw - Longitudinal	1
IDGB-14	103140	Cover	1	IDGB-49	112586	Screw - Cross	1
IDGB-15	109190	Gage - Setting	1	IDGB-50	103097	Swivel	1
IDGB-16	70198	Screw	2	IDGB-51	206058	Bearing - Roller	1
IDGB-17	2261	Screw	4	IDGB-52	103096	Spacer	1
IDGB-18	109183	Cover - Swivel	1	IDGB-53	206059	Bearing - Roller	1
IDGB-19	105139	Nut - Lock	1	IDGB-54	109184	Retainer - Bearing	1
IDGB-20	3791	Washer - Lock	1	IDGB-55	3203	Screw	4
IDGB-21	92733	Pin - 1/8"	1	106730		Base	1
IDGB-22	103098	Pin - Stop	1	IDGB-59	3479	Nut	2
IDGB-23	3472	Nut	2	IDGB-60	3442	Washer	2
IDGB-24	3231	Screw	2	IDGB-61	106731	Stud - In Base	1
IDGB-25	2285	Screw	2	IDGB-62	103134	Shoe - Swivel Clamp	1
IDGB-26	2333	Screw	1	IDGB-63	103133	Clamp - Swivel	1
IDGB-27	109185	Shoe - Locking	1	IDGB-64	103135	Screw - For Dog	1
IDGB-28		Scale - Cross		IDGB-65	2282	Screw	1
	112588	Inch System	1	IDGB-66	103135	Screw - For Dpg	2
	112569	Metric	1	IDGB-67	3472	Nut	2
IDGB-29	112567	Gib - Support	1	IDGB-68	159914	Screw	2
IDGB-30	3204	Screw	4	IDGB-69	159913	Clamp	2
IDGB-31	3270	Pin	2	IDGB-70	3274	Bolt - Tee	2
IDGB-32	103100	Apron - On Slide	1	IDGB-71	3312	Tongue	2
IDGB-33	103099	Slide	1	IDGB-72	3486	Screw	2
IDGB-34	3231	Screw	3	IDGB-73	3807	Washer - Lock	1
IDGB-35	3472	Nut	2	IDGB-74	3808	Nut - Lock	1
IDGB-36	3270	Pin	2	IDGB-75	103136	Nut - Dog, Screw	3
IDGB-37	2265	Screw	1	IDGB-76		Dog	
IDGB-38	103139	Pointer	1	150130		Left Hand	1
IDGB-39	103103	Collar - Screw	1	103131		Right Hand	1
				IDGB-77	103132	Screw - Adjusting, Dog	2

CINCINNATI **No. 2 CUTTER AND TOOL GRINDER**

NO.1 RADIUS GRINDING ATTACHMENT

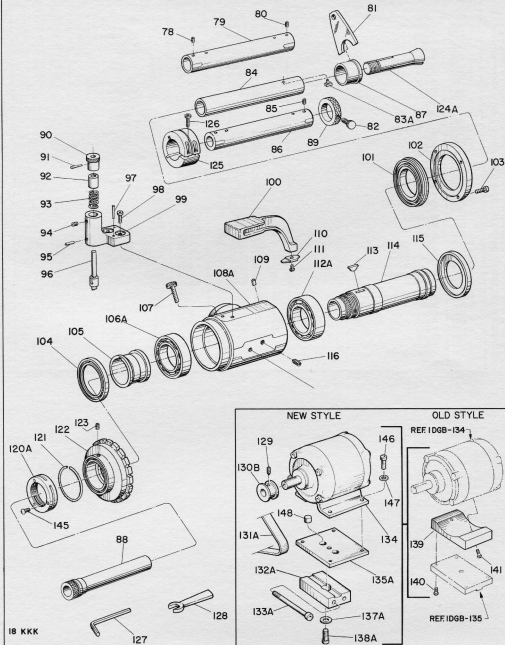

RADIUS GRINDING ATTACHMENT - No.1 - UNIT 1 DGB (Concluded)

KEY NO.	PART NO.	PART NAME	AMT. USED	KEY NO.	PART NO.	PART NAME	AMT. USED	
IDGB-78	2330	Screw (c)	4	IDGB-115	103117	Ring - Dust, Inner Front	1	
IDGB-79	109197	Sleeve - In Spindle, 1" to 1-1/4" (c)	1	IDGB-116	1911	Screw (Omit from Standard Attachment)	2	
		Shank (c)	1	IDGB-120A	408203	Nut - On Spindle	1	
IDGB-80	2358	Screw (c)	4	IDGB-121	103123	Washer - Felt	1	
IDGB-81	109189	Extractor - Collet (b)	1	IDGB-122	103122	Dial - Cutter, Setting	1	
IDGB-82	109182	Screw - Thumb (b)	1	IDGB-123	78600	Screw	1	
IDGB-83A	109203	Key - Draw In, Collet (d)	1	IDGB-124A		Collet - Draw In	1	
IDGB-84	109201	Sleeve - Draw In, Collet (d)	1		186652-8	1/8" (e)	1	
IDGB-85	2330	Screw (c)	8		186652-12	3/16" (e)	1	
IDGB-86	109195	Sleeve - In Spindle, 3/4" to 7/8" (c)	1		186652-16	1/4" (e)	1	
		Shank (c)	1		186652-20	5/16" (e)	1	
IDGB-87		Adapter - Spindle (b)	1		186652-24	3/8" (e)	1	
	146028	#12 B & S Taper (b)	1		186652-28	1/16" (e)	1	
	109193	#5 Morse Taper (b)	1		186652-32	1/2" (e)	1	
IDGB-88	109202	Bolt - Draw In (d)	1		186652-36	9/16" (e)	1	
IDGB-89	109194	Collar - Stop (b)	1		186652-40	5/8" (e)	1	
IDGB-90	103129	Knob - Index Pin	1	IDGB-125	109192	Clamp - For Sleeve (b)	1	
IDGB-91	140	Pin - Taper	1	IDGB-126	3204	Screw (b)	2	
IDGB-92	103127	Bushing - Index Lock	1	IDGB-127		Wrench	1	
IDGB-93	253	Spring	1		216584	For #10 Set Screw (b)	1	
IDGB-94	103128	Screw - Set, Index Bracket	1		4047	3/16" Allen (b)	1	
IDGB-95	2160	Pin	1		4053	1/8" Allen (b)	1	
IDGB-96	103126	Pin - Index Bracket	1	IDGB-128	4080	Wrench - 1/2" End (a)	1	
IDGB-97	3304	Pin	2	IDGB-129	2330	Screw (a)	1	
IDGB-98	3209	Screw	2	IDGB-130B	305147	Pulley - Motor (a)	1	
IDGB-99	103125	Bracket - Index Pin	1	IDGB-131A	307485	Belt - Extension (a)	1	
IDGB-100	103142	Bracket - Centering Gage	1	IDGB-132A	307488	Bracket - Motor (a)	1	
IDGB-101	103118	Ring - Dust, Front	1	IDGB-133A	343086	Screw (a)	2	
IDGB-102	103119	Cover - Workhead	1	IDGB-134	Example	*Motor (a)	1	
IDGB-103	3203	Screw	4	IDGB-135A	307487	Plate - Motor (a)	1	
IDGB-104	103121	Ring - Dust	1	IDGB-137A	40238	Washer (a)	1	
IDGB-105	114528	Sleeve - Dial Setting	1	IDGB-138A	3251	Screw (a)	1	
IDGB-106A	189648	Bearing - Ball	1	IDGB-139	163646	Plate - Motor (With Robins and Myers Motor) (a)	1	
IDGB-107	103124	Screw - Clamp Spindle	1		186652-140	2363	Screw (With Robins and Myers Motor)(a)	4
IDGB-108A	189628	Head - Work	1	IDGB-141	Example	Screw (Part of Item 134)	1	
IDGB-109	60062	Cup - Oil, 1/4"	1	IDGB-145	2366	Screw	3	
IDGB-110	65815	Plate - Centering Gage	1	IDGB-146	Example	Screw	4	
IDGB-111	3460	Screw	1	IDGB-147	Example	Washer	4	
IDGB-112A	189646	Bearing - Ball	1	IDGB-148	3529	Plug	2	
IDGB-113	3279	Key	1					
IDGB-114		Spindle - Workhead	1					
	146027	#12 B & S Outside Taper	1					
	109191	#5 Morse Taper	1					

* State serial number of machine when ordering parts by name.

() Parenthetical suffixes correspond to lettered sections of extra cost equipment in CMMCo. price list under Item 1.

NO.2 RADIUS GRINDING ATTACHMENT

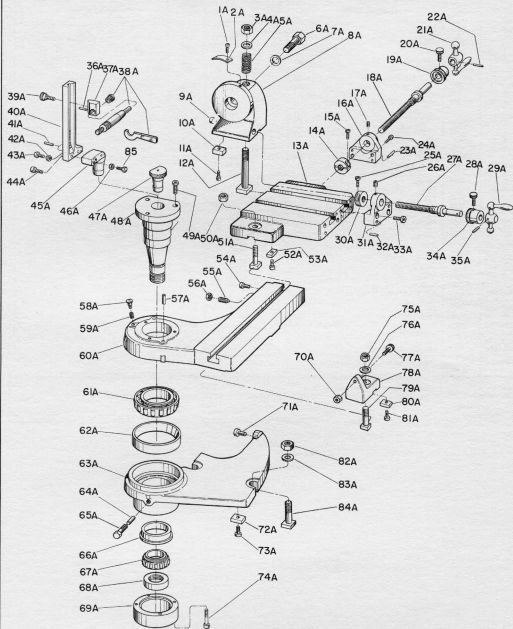

97 KKK

RADIUS GRINDING ATTACHMENT - NO. 2 - UNIT 1 DEJ

KEY NO.	PART NO.	PART NAME	AMT. USED	KEY NO.	PART NO.	PART NAME	AMT. USED
I1DEJ-1A	2385	Screw	2	I1DEJ-45A	3378	Screw	1
I1DEJ-2A	117090	Scale - On Support	1	I1DEJ-44A	3396	Screw	2
I1DEJ-3A	3479	Nut	1	I1DEJ-45A	127303	Base - Radius Gage	1
I1DEJ-4A	3442	Washer	1	I1DEJ-46A	3472	Nut	1
I1DEJ-5A	3853	Spring	1	I1DEJ-47A	117095	Plug - Swivel Shaft	1
I1DEJ-6A	2122	Screw	1	I1DEJ-48A	117078	Shaft - Swivel	1
I1DEJ-7A	1040	Washer	1	I1DEJ-49A	3359	Screw	3
I1DEJ-8A	176298	Support - Workhead	1	I1DEJ-50A	3479	Nut	2
I1DEJ-9A	3530	Plug	1	I1DEJ-51A	3274	Bolt	2
I1DEJ-10A	3312	Tongue - Support	2	I1DEJ-52A	3486	Screw	2
I1DEJ-11A	3486	Screw	2	I1DEJ-55A	3312	Tongue	2
I1DEJ-12A	117092	Bolt - Tee, Support	1	I1DEJ-54A	117080	Pin - Stop	1
I1DEJ-13A	117087	Plate - Top	1	I1DEJ-55A	3237	Screw	1
I1DEJ-14A	117083	Nut - Adjusting Screw	1	I1DEJ-56A	3478	Nut	1
I1DEJ-15A	3200	Screw	1	I1DEJ-57A	1385	Pin	2
I1DEJ-16A	117081	Housing - Adjusting Screw	1	I1DEJ-56A	44990	Giler	1
I1DEJ-17A	1205	Screw	1	I1DEJ-58A	1896	Plug	1
I1DEJ-18A	117082	Screw - Adjusting	1	I1DEJ-60A	128610	Table - Swivel	1
I1DEJ-19A		Dial - Adjusting Screw		I1DEJ-61A	117078	Cone - Roller Bearing	1
	117085	Inch System	1	I1DEJ-62A	117075	Cup - Roller Bearing	1
	117086	Metric	1	I1DEJ-62A	117073	Housing - Swivel	1
I1DEJ-20A	2255	Screw - Thumb	1	I1DEJ-64A	120362	Pin - Straight	1
I1DEJ-21A	101842	Crank - Ball	1	I1DEJ-65A	52	Screw	1
I1DEJ-22A	2291	Pin	1	I1DEJ-66A	62189	Cup - Roller Bearing	1
I1DEJ-23A	1421	Pin	2	I1DEJ-67A	62188	Cone - Roller Bearing	1
I1DEJ-24A	3251	Screw	2	I1DEJ-68A	227195	Nut - Shoe Type	1
I1DEJ-25A	3200	Screw	1	I1DEJ-68A	117077	Cover	1
I1DEJ-26A	1205	Screw	1	I1DEJ-70A	3478	Nut	1
I1DEJ-27A	117082	Screw - Adjusting	1	I1DEJ-71A	117080	Pin - Stop	1
I1DEJ-28A	2255	Screw - Thumb	1	I1DEJ-72A	3312	Tongue	2
I1DEJ-29A	101842	Crank - Ball	1	I1DEJ-73A	3486	Screw	2
I1DEJ-30A	117083	Nut - Adjusting Screw	1	I1DEJ-74A	3217	Screw	4
I1DEJ-31A	117081	Housing - Adjusting Screw	1	I1DEJ-75A	3479	Nut	1
I1DEJ-32A	1421	Pin	2	I1DEJ-76A	3442	Washer	1
I1DEJ-33A	3251	Screw	2	I1DEJ-77A	97206	Screw - Thumb	1
I1DEJ-34A		Dial - Adjusting Screw		I1DEJ-78A	117096	Stop - Bracket	1
	117085	Inch System	1	I1DEJ-79A	3311	Bolt - Tee	1
	117086	Metric	1	I1DEJ-80A	3312	Tongue	2
I1DEJ-35A	2291	Pin	1	I1DEJ-81A	3486	Screw	2
I1DEJ-36A	3540	Pin	1	I1DEJ-82A	3479	Nut	2
I1DEJ-37A	180274	Holder - Micrometer	1	I1DEJ-83A	3442	Washer	2
I1DEJ-38A		Micrometer - Barrel		I1DEJ-84A	117074	Bolt - Tee	2
	117099	Inch System	1	I1DEJ-85	3378	Screw	1
	117094	Metric	1				
I1DEJ-39A	178	Screw - Thumb	1				
I1DEJ-40A	180273	Support - Radius Gage	1				
I1DEJ-41A	3540	Pin	2				
I1DEJ-42A	3472	Nut	1				

FACE MILL GRINDING ATTACHMENT

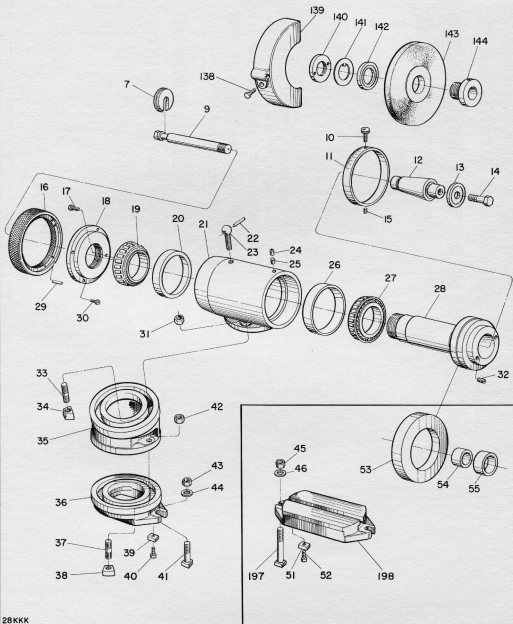

28KKK

FACE MILL GRINDING ATTACHMENT - UNIT 1 DCA

KEY NO.	PART NO.	PART NAME	AMT. USED	KEY NO.	PART NO.	PART NAME	AMT. USED
1DCA-7	68640	Washer - Draw Bolt	1	1DCA-35	68645	Plate - Angle	1
1DCA-9	68636	Bolt - Draw	1	1DCA-36	68646	Base	1
1DCA-10	2255	Screw - Thumb	1	1DCA-37	92861	Stud	2
1DCA-11	68658	Dial	1	1DCA-38	68644	Clamp	2
1DCA-12	68637	Arbor	1	1DCA-39	3312	Tongue	2
1DCA-13	68642	Washer	1	1DCA-40	3486	Screw	2
1DCA-14	183	Screw	1	1DCA-41	3311	Bolt - Tee	2
1DCA-15	1786	Screw	1	1DCA-42	3479	Nut	2
1DCA-16	68639	Ring - Spindle Nut	1	1DCA-43	3479	Nut	2
1DCA-17	2103	Screw	1	1DCA-44	3442	Washer	2
1DCA-18	68638	Nut - Adjusting	1	1DCA-45	3479	Nut	2
1DCA-19	58587	Cone - Bearing	1	1DCA-46	3442	Washer	2
1DCA-20	36568	Cup - Bearing	1	1DCA-51	3312	Tongue	2
1DCA-21	68648	Head - Work	1	1DCA-52	3486	Screw	2
1DCA-22	3537	Handle	1	1DCA-53	68659	Plate - Adapter	1
1DCA-23	3538	Screw	1	1DCA-54	68661	Bushing - Arbor	1
1DCA-24	68663	Cup - Oil	2	1DCA-55	68662	Bushing - Arbor	1
1DCA-25	1836	Flag - Fell	2	1DAW-138	49	Screw	1
1DCA-26	57869	Cup - Bearing	1	1DAW-139	65376	Guard	1
1DCA-27	56867	Cone - Bearing	1	1DAW-140	157756	Nut - Collar	1
1DCA-28	71866	Spindle	1	1DAW-141	188829	Washer - Lock	1
1DCA-29	3541	Pin	1	1DAW-142	157755	Collar - Spacing, 3/8"	1
1DCA-30	3464	Screw	4	1DAW-143	74012	Wheel - Grinding 8 x 1/16 x 1-1/4 Straight Side	1
1DCA-31	3479	Nut	2	1DAW-144	188705	Collar	1
1DCA-32	1215	Screw	2	1DJF-197	68660	Bolt - Block Raising	2
1DCA-33	92861	Stud	2	1DJF-198	68663	Block - Raising	1
1DCA-34	68644	Clamp	2				

SURFACE GRINDING ATTACHMENT

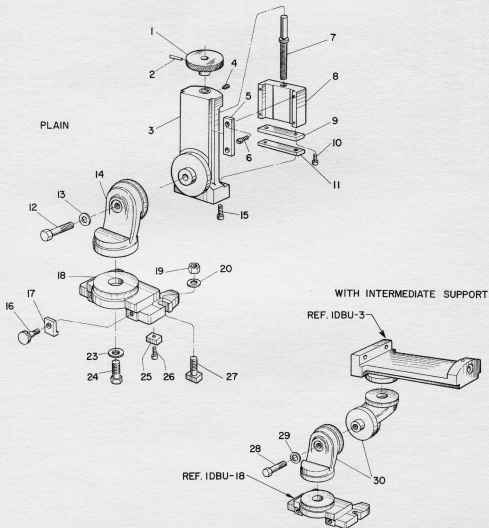

13 KKK

SURFACE GRINDING ATTACHMENT - UNIT 1 DBU

KEY NO.	PART NO.	PART NAME	AMT. USED	KEY NO.	PART NO.	PART NAME	AMT. USED
IDBU-1	103480	Knob - On Screw	1	IDBU-15	3495	Screw	2
IDBU-2	141	Pin - Taper	1	IDBU-16	159914	Screw	2
IDBU-3	62563	Body - Surface Grinding Attachment	1	IDBU-17	159913	Clamp - Workhead	2
IDBU-4	1205	Screw	1	IDBU-18	156160	Plate - Workhead	1
IDBU-5	62494	Clamp - Vise	2	IDBU-19	3479	Nut	2
IDBU-6	3486	Screw	4	IDBU-20	3442	Washer	2
IDBU-7	62463	Screw - Vise	1	IDBU-23	1040	Washer	1
IDBU-8	62491	Slide	1	IDBU-24	3428	Screw	1
IDBU-9	7319	Jaw - On Housing	1	IDBU-25	3312	Tongue	2
IDBU-10	1145	Screw	2	IDBU-26	3486	Screw	2
IDBU-11	62492	Jaw - Body	1	IDBU-27	3311	Bolt - Tee	2
IDBU-12	3427	Screw	1	IDBU-28	3427	Screw	1
IDBU-13	1040	Washer	1	IDBU-29	1040	Washer	1
IDBU-14	62700	Support - Vise Body	1	IDBU-30	62700	Support - Vise	2

LONG REAMER GRINDING ATTACHMENT

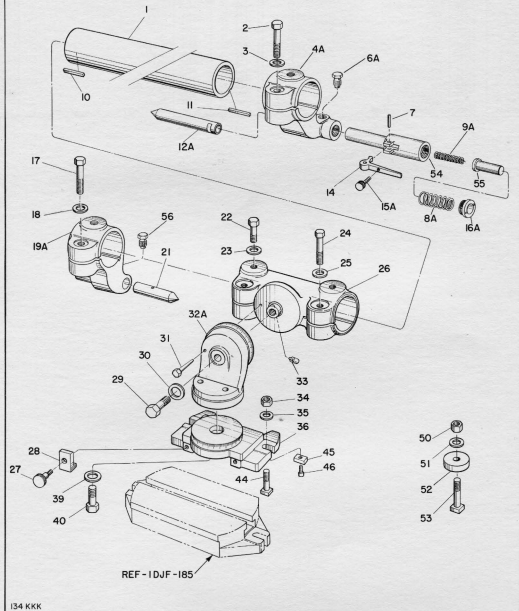

LONG REAMER GRINDING ATTACHMENT - UNIT 1 DBZ

KEY NO.	PART NO.	PART NAME	AMT. USED	KEY NO.	PART NO.	PART NAME	AMT. USED
1DBZ-1	46252	Bar - Adjusting	1	1DBZ-27	159914	Screw	2
1DBZ-2	1953	Screw	1	1DBZ-28	159913	Clamp - Workhead	2
1DBZ-3	1035	Washer	1	1DBZ-29	3427	Screw	1
1DBZ-4A	191661	Bracket - Tailstock	1	1DBZ-30	1040	Washer	1
1DBZ-6A	143741	Screw	1	1DBZ-31	85432	Pin - Locating	1
1DBZ-7	3542	Pin	1	1DBZ-32A	66798	Support - Workhead	1
1DBZ-8A	143747	Spring	1	1DBZ-33	38103	Pin - In Bar Carrier	1
1DBZ-9A	150021	Spring	1	1DBZ-34	3479	Nut	2
1DBZ-10	1448	Key	1	1DBZ-35	3442	Washer	2
1DBZ-11	1448	Key	1	1DBZ-36	156160	Plate - Workhead	1
1DBZ-12A	143744	Center - Tailstock	1	1DBZ-39	1040	Washer	1
1DBZ-14	143740	Lever - For Tailstock	1	1DBZ-40	3428	Screw	1
1DBZ-15A	77290	Screw	1	1DBZ-44	3311	Bolt - Tee	2
1DBZ-16A	143748	Cap	1	1DBZ-45	3312	Tongue	2
1DBZ-17	1953	Screw	1	1DBZ-46	3486	Screw	2
1DBZ-18	1035	Washer	1	1DBZ-50	3479	Nut	1
1DBZ-19A	191660	Bracket - Headstock	1	1DBZ-51	3442	Washer	1
1DBZ-21A	64099	Center - Headstock	1	1DBZ-52	46249	Collar - Tooth Rest	1
1DBZ-22	383	Bolt	1	1DBZ-53	3366	Bolt - Tee	1
1DBZ-23	1035	Washer	1	1DBZ-54	143746	Housing - Tailstock	1
1DBZ-24	1953	Screw	1	1DBZ-55	143749	Plunger - Spring	1
1DBZ-25	1035	Washer	1	1DBZ-56	143741	Screw	1
1DBZ-26	66797	Carrier - Bar	1				

INSTRUCTION PLATES

KEY NO.	PART NO.	PART NAME	AMT. USED	KEY NO.	PART NO.	PART NAME	AMT. USED
1	3966	Plate - Name, Cincinnati	1	8		Plate - Electrical Direction, 24"	
2	313696	Plate - Spindle Direction	1			Table Travel With Power Feed	
3	316056	Plate - Control	1		173032	With or Without Coolant	1
4	195338	Plate - Radius Grind, "On" and "Off"	1		196482	Symbolized	1
5		Plate - Instruction, Crossfeed Screw			159997	Alteration - With or Without Coolant, with Radius Grinding Attachment and End Mill Grinding Attachment	
	156821	English	1				
	196478	Symbolized	1				
6	181913	Plate - Instruction, 50 Hz	1	9	170781	Plate - Coolant "On" and "Off"	1
7	167308	Plate - Instruction, 60 Hz	1				

For other plates see RP-30

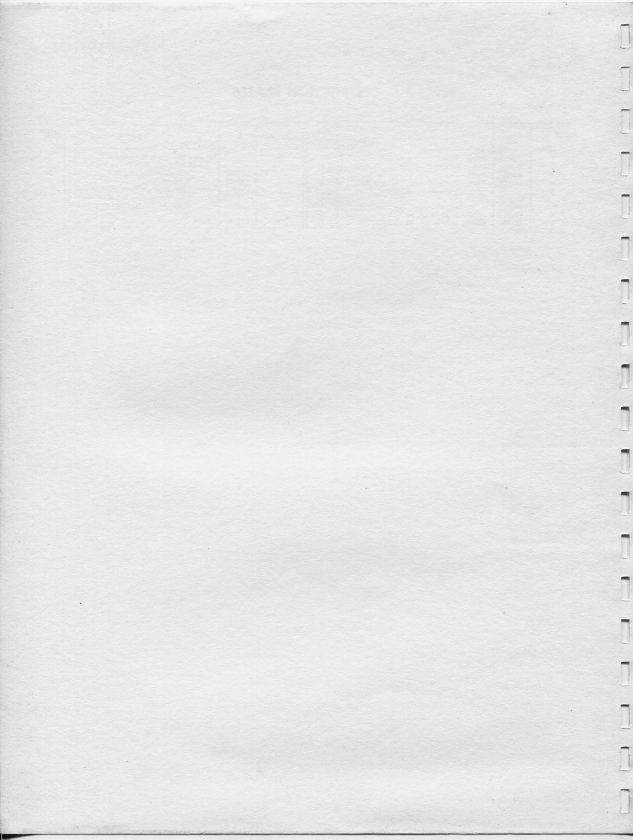



Cincinnati Milacron Company | Cincinnati, Ohio 45209

Machine Tools
Process Controls
Chemicals
Plastics
Plastics Processing Machinery
Abrasives