

Logan

LATHES

SHAPERS • ACCESSORIES

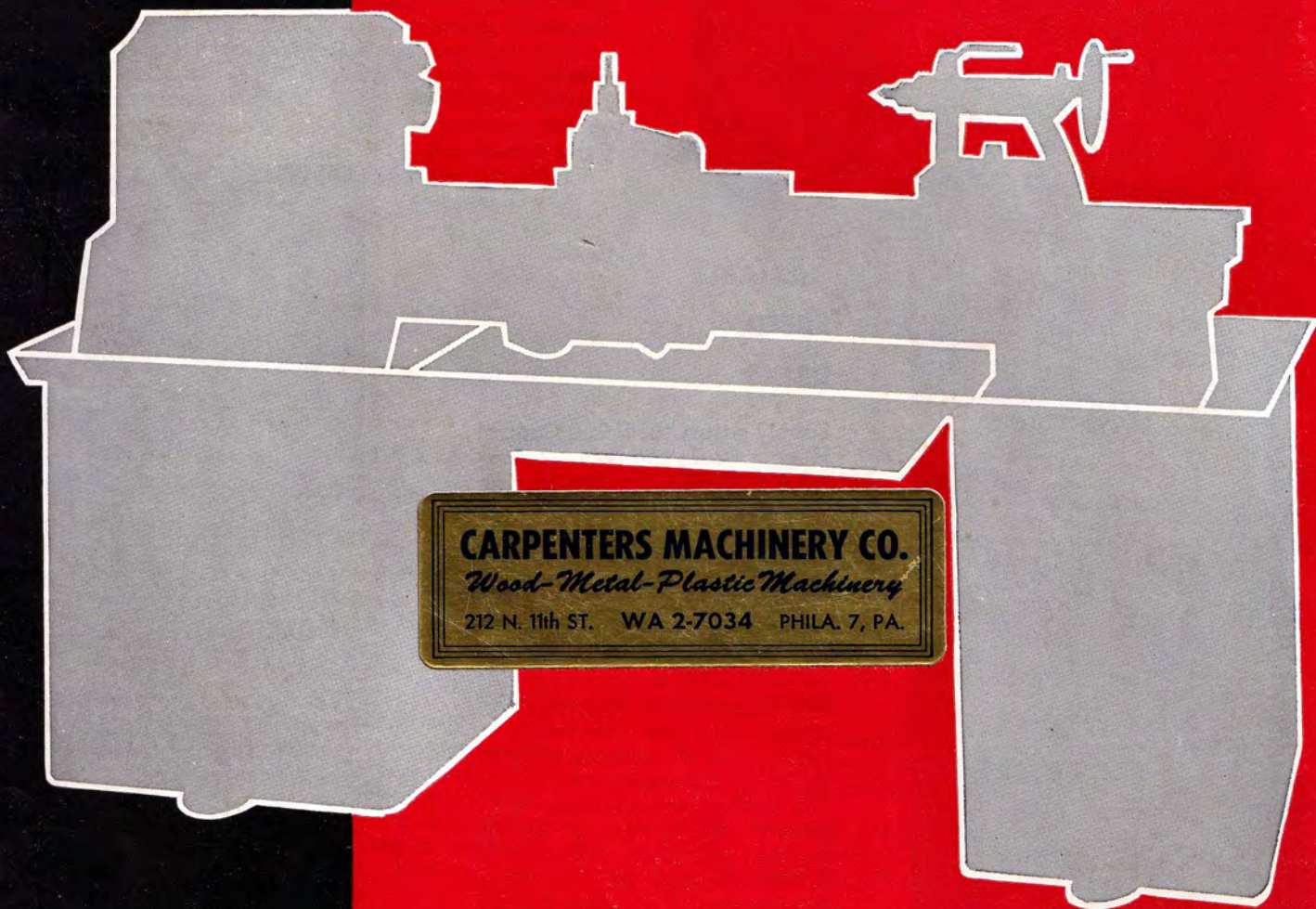

CARPENTERS MACHINERY CO.
Wood-Metal-Plastic Machinery
212 N. 11th ST. WA 2-7034 PHILA. 7, PA.

LOGAN ENGINEERING CO. • 4901 W. LAWRENCE AVE. • CHICAGO 30, ILL.

ADVANCED DESIGN . . . RUGGED CONSTRUCTION . . .

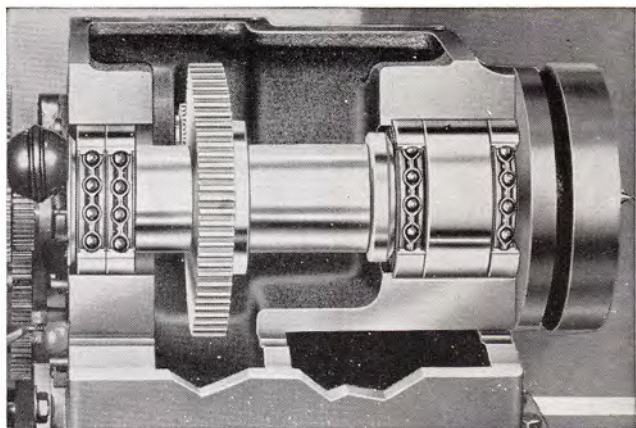

BALL BEARING HEADSTOCK and SPINDLE

The headstock on every Logan Lathe is designed, built and balanced for rigidity, and for smooth power, free from noise or vibration. The Logan 12" lathe headstock illustrated shows the massive proportions of the Logan spindle with $1\frac{3}{8}$ " bore, and the ball bearing mounting that needs no adjustment for any standard rpm. Logan 9", 10" and 11" lathes also have ball bearing spindles that assure sustained accuracy and permit using high speed carbide tipped cutting tools to fullest advantage. Logan 14" Lathes have a headstock and spindle of the same basic design as that shown, but of heavier and more powerful construction.

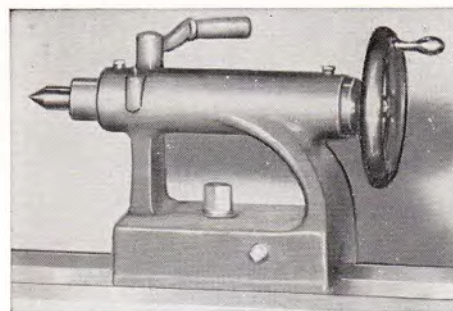

RIGIDLY CONSTRUCTED TAILSTOCK

Tailstocks on all Logan Lathes are easy to handle and provide rigid support of the work. The 14" lathe tailstock shown typifies Logan construction. It is bored for a No. 3 Morse taper. The spindle travel is $5\frac{1}{2}$ " in graduations of $\frac{1}{16}$ ". Set-over for taper turning is $\frac{9}{16}$ ".

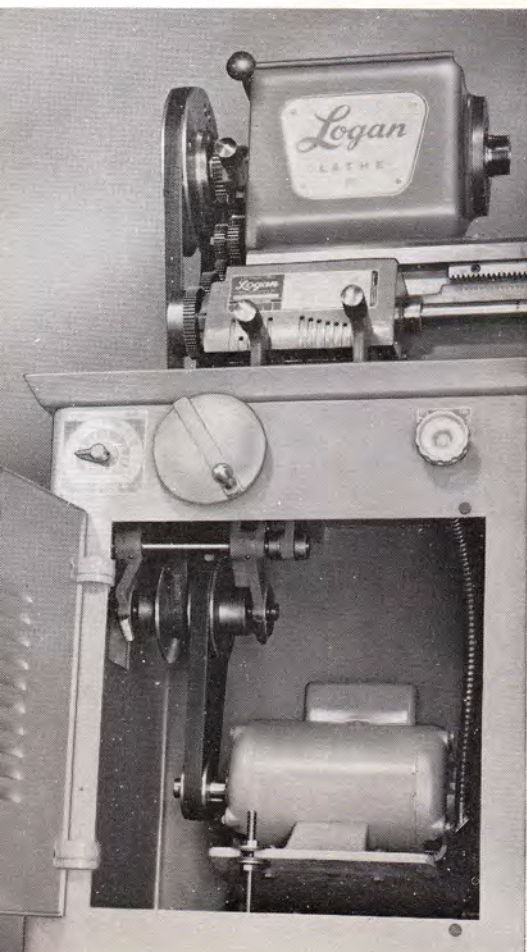

VARIABLE SPEED DRIVE

Simply adjust the Speed Control Handle *while the lathe is running* to obtain any desired rpm within the speed range of a Logan Variable Speed drive lathe. There is no stopping of the lathe, no shifting of belts. The speed control handle is synchronized with an easily readable rpm indicator which gives instant visual indication of spindle speed. Motor and drive assembly are enclosed and easily accessible in the lower left compartment of the cabinet base. Logan 12" and 14" Lathes are available with infinite speeds from 55 to 300 R.P.M. and from 350 to 2000 R.P.M. Models 6565 and 6530 have speeds of 50 to 310 R.P.M. and 340 to 2000 R.P.M.

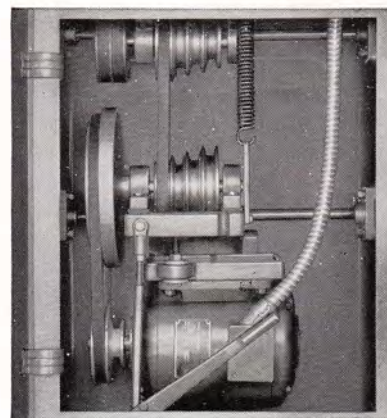

BALL BEARING UNDERNEATH V-BELT DRIVE

The motor drive assembly of Logan 10" and 11" cabinet base lathes is completely self-contained and is enclosed in the compartment below the headstock. The jackshaft and countershaft turn on ball bearing mountings. Belt tension is released by simply adjusting the lever on the right side of the compartment. Motor and all drive parts are easily accessible.

... SUSTAINED ACCURACY

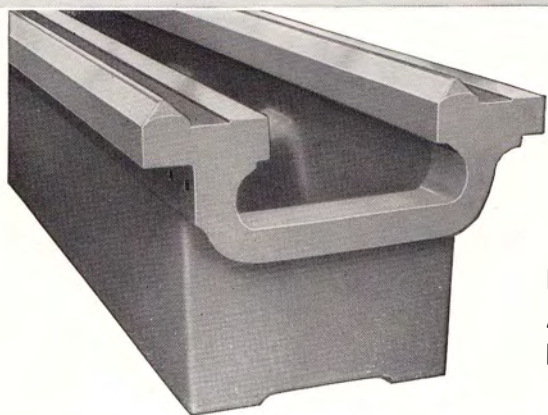

RUGGED, ACCURATE BED

The Logan 14" lathe bed illustrated here is 68" long and 10" wide, with high, strong walls braced by over-size ribs. Like all Logan lathe beds, it withstands the heaviest bending and torsional stresses. Balanced sections of even thickness neutralize internal stresses. Special alloy construction, and thorough seasoning before and between machining operations make the Logan bed warp-free. The two V-ways and two flat ways on every Logan Lathe bed are precision ground. Flame hardened beds are available on 10", 11", 12" and 14" lathes.

PRECISION CARRIAGE

The carriage of every Logan Lathe is built for rigidity, accuracy and convenience. With its double-walled apron, lever-operated spring loaded disc type clutch, and large, legible dials the 14" lathe carriage shown is typical of Logan carriages. Large tool post and heavy compound add to rigidity. Longitudinal and cross feeds operate from spline in lead screw through worm drive and friction clutch. Additional half-nut drive from lead screw for thread cutting. Automatic lock prevents either feed from operating while the other is engaged. Gears run in oil bath.

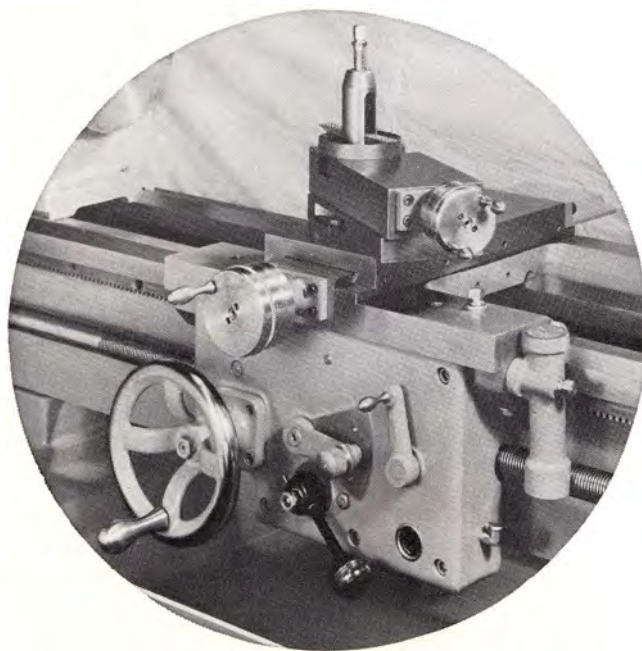

QUIET GEARS

Wide, rugged, machine-cut gears are characteristic of all Logan Lathes. Shown are the quiet-running gears of the Logan 14" lathe. The special "Ductile Iron" change gears of this lathe have as much as triple the strength of cast iron gears and tensile strength superior to most steel gears. Convenient levers. Automatic Safety Gear as described on page 17 is standard equipment on all 14", 12", 11" lathes and 1825, 1875 10" lathes.

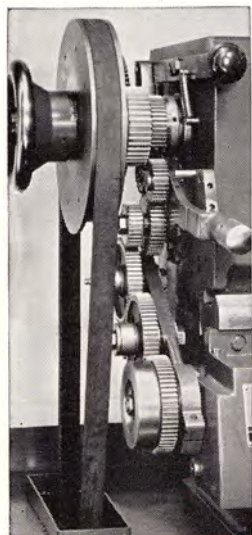

CONVENIENT STORAGE

The Logan Cabinet Base Lathes, except the 14" x 28", have a drop center pan with extra chip capacity and provide storage space in the tail-stock pedestal.

3 compartments (as illustrated) with built-in lock in the door.

*3 pull-out drawers with individual or built-in lock for each drawer.

*Available in 10", 11", and 12" Lathes only.



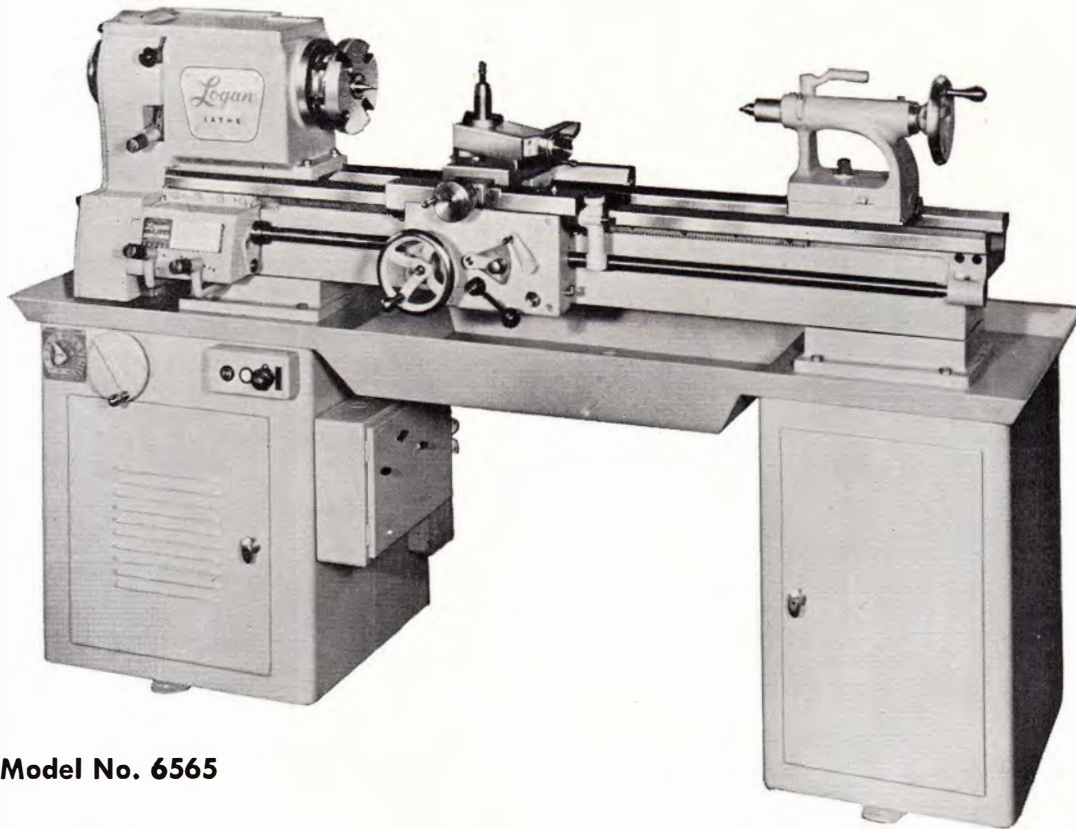

Model No. 6565

Logan builds extra dependability into every part of this big, rugged screw-cutting lathe. It takes the heaviest cuts with no perceptible vibration. The variable-speed drive lets you change speed while the work is turning . . . *without* the trouble of shifting belts.

The oversize spindle, with 1 $\frac{5}{8}$ -in. bore, turns on precision ball bearings that need no adjustment within the

full range of spindle speeds. And these bearings maintain their accuracy far longer than other types of bearings.

These are only a few of the many other advanced design and construction features engineered into this Logan lathe:

SPECIFICATIONS—LOGAN 14" ENGINE LATHE

CAPACITY OF LATHE

Swing over bed 14 $\frac{5}{8}$ "
 Swing over cross slide 9"
 Between centers 40"

THREADS AND FEEDS

Quick Change gear box and automatic apron.
 Worm drive from lead screw spline for power feeds.
 Longitudinal feed .0006" to .0350" per spindle revolution.
 Cross feed .6 times longitudinal feed.
 Half nut drive from lead screw thread for thread cutting.
 Threads, 48 selections R.H. or L.H.—4 to 224 per inch
 Lead screw diameter and threads per inch—1 $\frac{1}{8}$ -8.

HEADSTOCK AND SPINDLE

Hole through spindle 1 $\frac{5}{8}$ " clearance
 Spindle bearings: Super Precision Ball Bearings
 Heat-treated and ground steel spindle
 Spindle nose L-O
 Variable speed drive, direct, 340 to 2000 rpm; back gears engaged, 50 to 310 rpm

CROSS SLIDE AND COMPOUND REST

Cross slide travel 10"
 Compound rest travel 4"
 Compound rest graduated 90° in both directions
 Tool post opening for 1 $\frac{1}{2}$ " x 1 $\frac{1}{8}$ " tool holder

BED

Width of bed across ways 10"
 Length of bed 68"
 Precision-ground ways, two prismatic V-ways and two flat ways

Flame-Hardened Ways

TAILSTOCK

Spindle travel 5 $\frac{1}{2}$ "
 Spindle graduation 1/16"
 Morse taper center #3
 Tailstock set-over for taper turning . . . 9/16"

UNDERNEATH DRIVE

Ball Bearing Variable Speed

MOTOR AND CONTROLS

(priced separately)

3 hp 1725 rpm, 3 ph. motor recommended.
 Drum switch or reversing magnetic motor starter with pushbutton controls available
 Dinabrake or two-speed motor also available

DIMENSIONS

82" L—29" W—51" H

EQUIPMENT INCLUDED WITH LATHE

7 $\frac{1}{2}$ " drive plate, 2 No. 3 M.T. 60° centers, threading dial, threading chart, tool post and wrench, motor pulley, automatic safety gear, spindle adapter sleeve to No. 3 M.T., tailstock wrench, and necessary belts.
 Shipping Weight Approx. 1950 lbs.

IMPORTANT

If lathe is ordered less motor, a \$25.00 charge will be made for installing a motor for final inspection of the lathe and the motor removal prior to shipment.

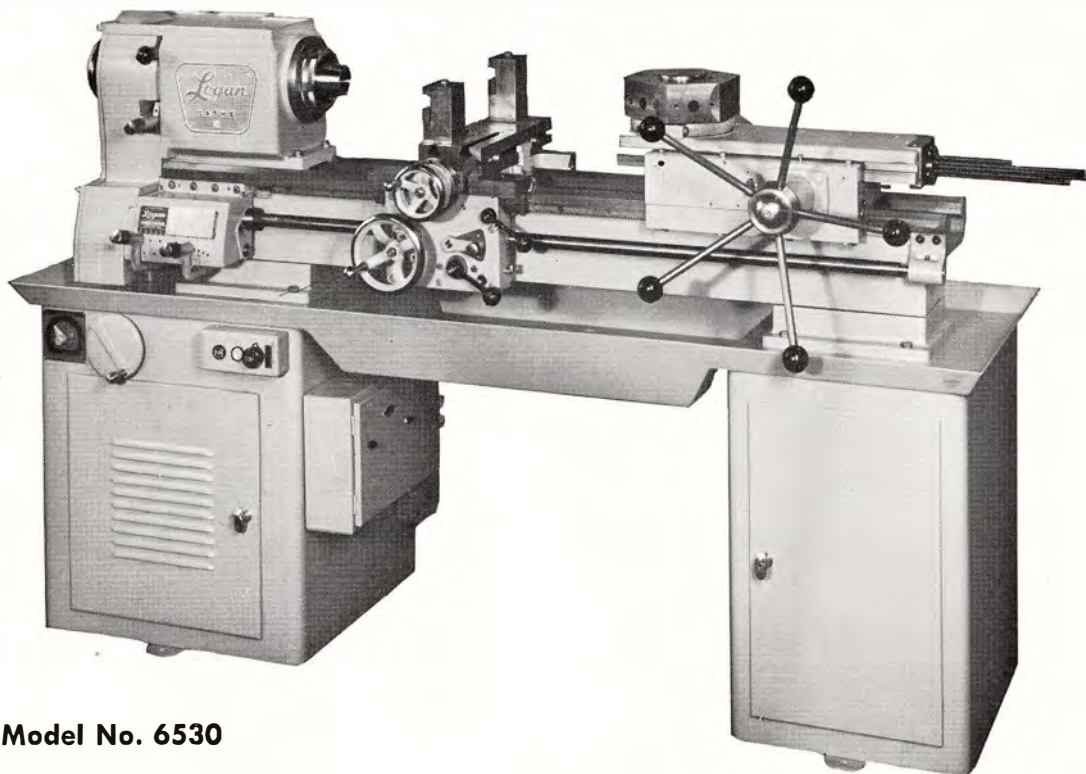

Model No. 6530

Extra heavy turret construction assures maximum smoothness and accuracy with this Logan lathe, which also embodies the basic engineering improvements found in the Logan 6565 engine lathe. For fast, flexible and

profitable operation with dependable holding of tolerances this is the turret lathe to buy. Logan lathes are noted for long-term accuracy.

LOGAN 14" TURRET LATHE SPECIFICATIONS

CAPACITY OF LATHE

Swing over bed.....14⁵/₈"
Swing over cross slide.....6⁷/₈"

CARRIAGE AND CROSS SLIDE FEEDS

Quick change gear box and automatic apron
Lever-operated safety clutch
Worm drive from feed rod spline for power feeds
Longitudinal feed......0006" to .0350" per spindle revolution
Cross feed...0.6 times (x) longitudinal feed

HEADSTOCK AND SPINDLE

Hole through spindle.....1⁵/₈" clearance
Spindle bearings: Super Precision Ball Bearings
Heat-treated and ground steel spindle
Spindle nose.....L-O
Variable-speed drive. Spindle speeds with two-speed motor.
Direct drive.
340 to 2000 rpm high motor speed
170 to 1000 rpm low motor speed
Back gears engaged.
50 to 310 rpm high motor speed
25 to 155 rpm low motor speed

DOUBLE TOOL POST CROSS SLIDE

Cross slide travel.....10"

Cross slide graduated in thousandths with position indicators
Triple-thread cross feed screw mounted on self-lubricating bronze bearings
Adjustable stops for cross slide movement
Adjustable double tool post with adjustable wedges
Tool post slots.....⁵/₈" x 2¹/₄"

BED

Width of bed across ways.....10"
Length of bed.....68"
Precision ground ways, two prismatic V-ways and two flat ways

Flame-Hardened Ways

UNDERNEATH DRIVE

Ball Bearing Variable Speed

MOTOR AND CONTROLS

(priced separately)

3 ph., 2-speed, 3-1¹/₂ hp—1800/900 rpm motor recommended
Drum switch or reversing magnetic motor starter with pushbutton controls
Dinabrake or single-speed motor also available

HEXAGON TURRET

Clearance, center of tool holes to top of turret cross slide.....2 9/16"
Turret head indexes and locks automatically
Width of turret block across flats.....8¹/₂"
Bolt holes in face: 7/16"—14 tpi
Turret block locked by cam operated locking ring
Maximum travel at one setting.....9"
Slide length.....24"
Base length.....17"
⁷/₈" machined holes can be bored up to 1¹/₂" diameter

OVERALL DIMENSIONS:

lathe less accessories

Length.....92"
Width.....30"
Height.....51"

STANDARD EQUIPMENT

Turret Lathe, as illustrated, except for motor and controls which are priced separately. Includes finish bored hexagon turret up to 1¹/₂" diameter holes. Specify hole size when ordering. All necessary belts and wrenches.

Shipping Weight.....Approx. 2200 lbs.

IMPORTANT

If lathe is ordered less motor, a \$25.00 charge will be made for installing a motor for final inspection of the lathe and the motor removal prior to shipment.

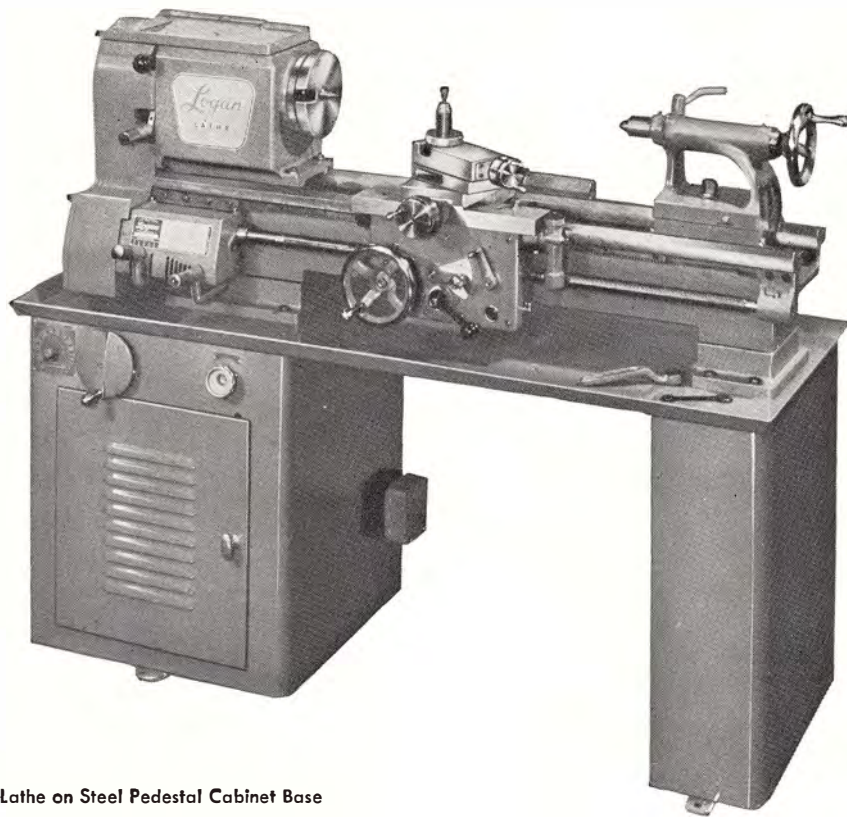

Model 6510
Screw Cutting Lathe on Steel Pedestal Cabinet Base

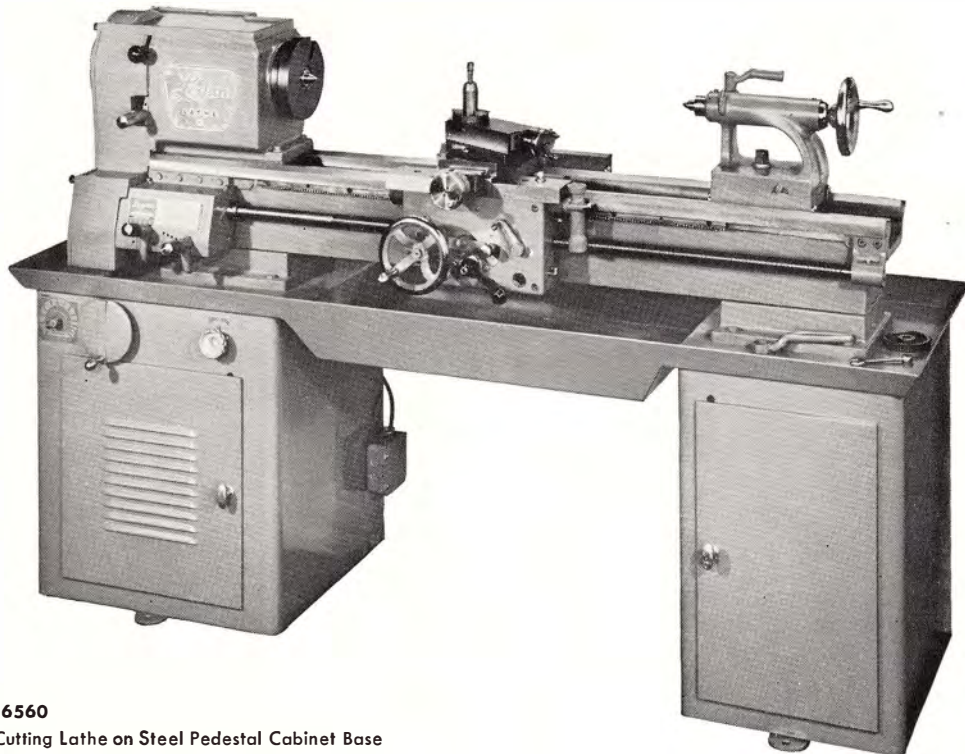

Model 6560
Screw Cutting Lathe on Steel Pedestal Cabinet Base

RESULTS PROVE THEIR SUPERIOR PERFORMANCE

- 14⁵/₈" Swing Over Bed
- 9" Swing Over Saddle
- 1³/₈" Spindle Hole
- 1¹/₁₆" Draw-in Collet Capacity
- 28" or 40" Between Centers
- Ball Bearing Variable Speed Drive
- Precision Carriage
- Ball Bearing Spindle
- 55 to 2000 R.P.M.
- Two V-Way, Two Flat Way, Precision Ground Bed

SCREW CUTTING LATHES

LATHE NO.		SHPG. WT. (LBS.)
6510	Q.C. Pedestal Base, 2 ¹ / ₄ "-8 Spindle, 28" Centers, Variable Speed Drive.....	1625
6510-H	Same as 6510 but with Hardened Bed-Ways.....	1625
6520	Q.C. Pedestal Base, L-00 Spindle, 28" Centers, Variable Speed Drive.....	1625
6520-H	Same as 6520 but with Hardened Bed-Ways.....	1625
6560	Q.C. Pedestal Cabinet Base, 2 ¹ / ₄ "-8 Spindle, 40" Centers, Variable Speed Drive.....	1850
6560-H	Same as 6560 but with Hardened Bed-Ways.....	1850
6561	Q.C. Pedestal Cabinet Base, L-00 Spindle, 40" Centers, Variable Speed Drive.....	1850
6561-H	Same as 6561 but with Hardened Bed-Ways.....	1850

No. 8081 Drop center chip pan for 6510 and 6520 lathes, factory installed in place of standard chip pan.

CAPACITY OF LATHE

Swing over bed.....14⁵/₈"
Swing over saddle cross slide.....9"
Center distance.....28" (6510).....40" (6560)

THREADS AND FEEDS

Quick change gear box and automatic apron.
Worm drive from lead screw spline for power feeds.
Longitudinal feed .0006" to .0350" per spindle revolution.
Cross feed .6 times longitudinal feed.
Half nut drive from lead screw thread for thread cutting.
Threads, 48 selections R.H. or L.H.—4 to 224 per inch.
Lead screw diameter and threads per inch—1¹/₈-8.

HEADSTOCK AND SPINDLE

Spindle bearings: (4) sealed and shielded precision ball bearings.
Heat-treated and ground steel spindle.
Hole through spindle—1³/₈".
Draw in Collet Capacity—1¹/₁₆".
Spindle nose diameter and threads per inch—2¹/₄-8.
Variable speed drive—Spindle speeds: Direct Drive—350 to 2000 rpm; with Back Gears Engaged—55 to 300 rpm.
Spindle nose adapter to #3 Morse.

CROSS SLIDE AND COMPOUND REST

Cross slide travel.....10"
Compound rest travel.....4"
Compound rest graduated 90° in both directions.
Tool post opening for 1/2" x 1¹/₈" tool holder.

BED

Width of bed across ways.....10"
Length of bed.....56" (6510).....68" (6560)
Precision ground ways, two prismatic V-Ways and two flat ways.

TAILSTOCK

Spindle travel.....5¹/₂"
Spindle graduation.....1¹/₁₆"
Morse taper center.....#3
Tailstock set-over from taper turning.....9⁹/₁₆"

UNDERNEATH DRIVE

Ball Bearing Variable Speed

MOTOR AND SWITCH

Use 2 H.P., 3 phase motor, 1725 R.P.M.
Drum type reversing switch furnished.

EQUIPMENT INCLUDED WITH LATHE

1—Drive plate } 7¹/₂" for 2¹/₄"-8 spindle
 } 7" for L-00 spindle
2—No. 3 M.T. 60° centers.
1—Threading dial. 1—Threading chart.
1—Tool post and wrench. 1—Motor pulley.
1—Automatic Safety Gear.
1—Drum reversing switch.
1—Spindle adapter sleeve to No. 3 M.T.
1—Tailstock Wrench.
Necessary Belts

OVERALL DIMENSIONS

6510.....66¹/₂" L, 27" W, 51" H
6560.....83" L, 27" W, 51" H

Important

To obtain maximum performance from the Logan 14" Lathe either purchase No. 1122 2 HP, 3 phase motor with the lathe or send us your own motor for installation on a cost basis in the lathe so that we can dynamically balance the complete unit. If a lathe is ordered less motor, a \$25.00 charge will be made for installing a motor for final inspection of the lathe and the motor removal prior to shipment.

S P E C I F I C A T I O N S

Logan 12" SWING LATHES

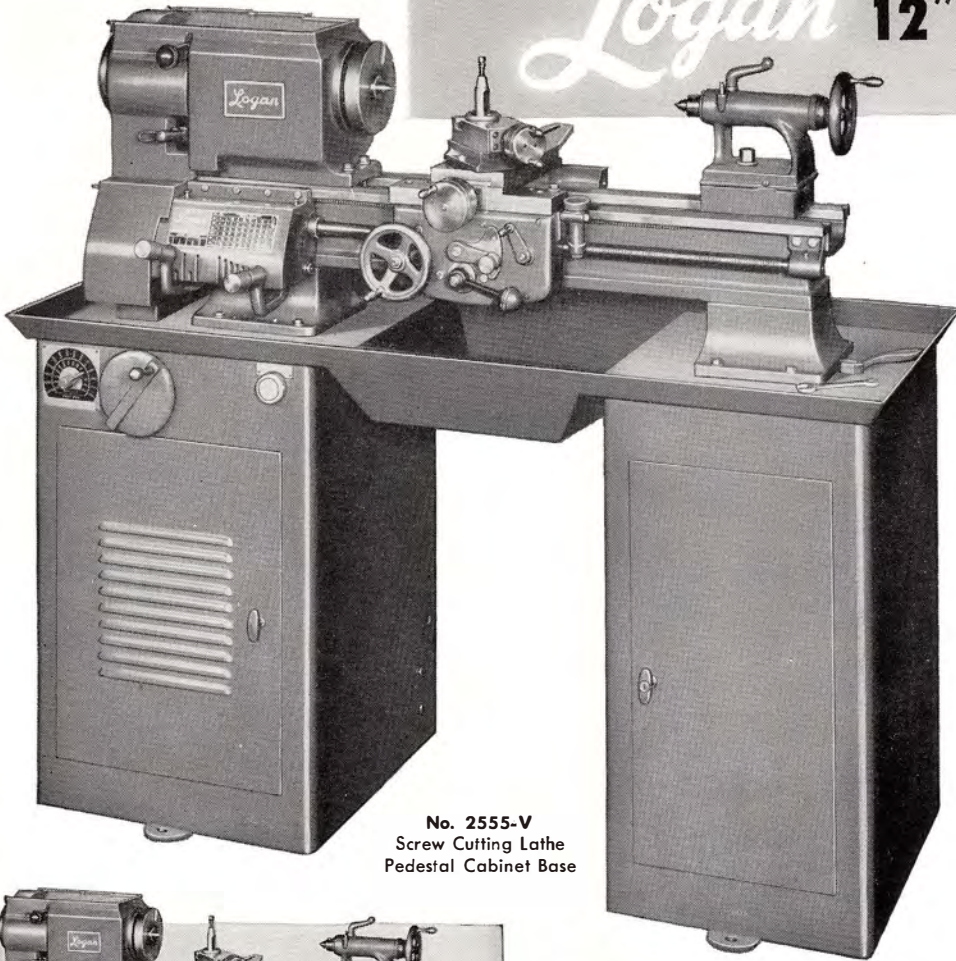

No. 2555-V
Screw Cutting Lathe
Pedestal Cabinet Base

- 1 1/16" COLLET CAPACITY
- 1 3/8" SPINDLE BORE
- 23" and 35" CENTERS
- VARIABLE SPEED DRIVE
- FLAME HARDENED BED
AT SMALL EXTRA COST

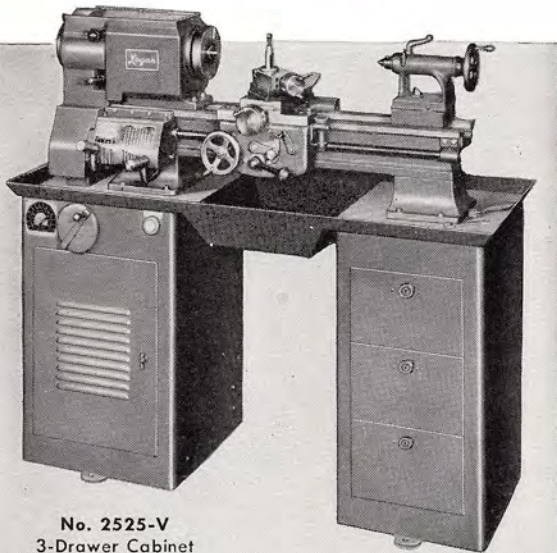

No. 2525-V
3-Drawer Cabinet
Screw Cutting Lathe.

Accuracy and smooth power are designed and built into these rugged, balanced lathes. Gears are extra wide and strong. Shafts are extra heavy. Lead screws have a full 7/8" diameter. The precision carriage rides on a two-V-way, two-flat-way bed that is rugged, precision-ground and warp-free. The heavy special alloy spindle turns on four oversize ball bearings, and needs no bearing adjustment for any speed within its wide rpm range. This advanced design plus precise, extra heavy construction and dynamic balancing of every completed lathe combine to assure sustained accuracy and smooth, quiet operation.

Compact all steel cabinet bases provide a clean-cut appearance and save floor space. Three compartments or three drawers inside each cabinet store and protect tools and work.

The Variable Speed Drive provides instant rpm adjustment on work requiring variation of spindle speed.

At only small extra cost, the bed is furnished flame hardened. The L-00 Spindle Nose also available at extra cost.

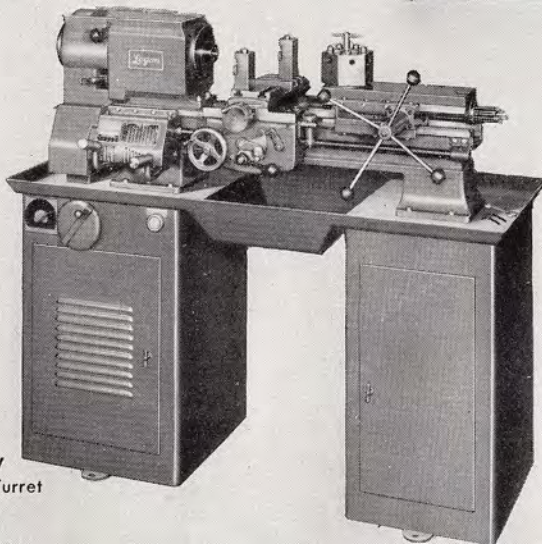

No. 2535-2-V
Pedestal Cabinet Turret
Lathe.

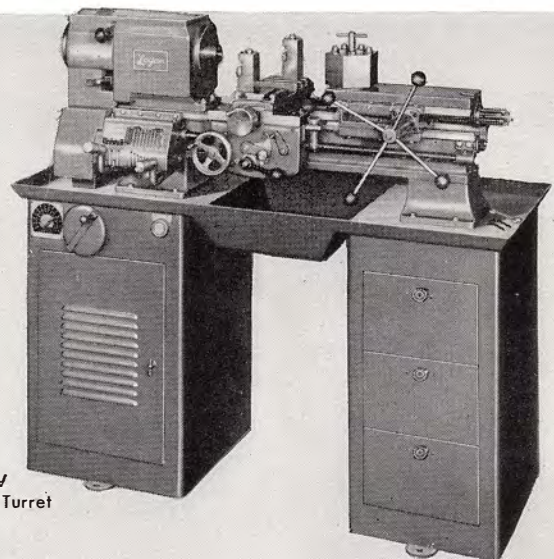

No. 2545-2-V
3-Drawer Cabinet Turret
Lathe.

CAPACITY OF LATHE

Swing over bed 12"
 Swing over saddle cross slide, screw cutting lathes $7\frac{1}{4}"$
 Swing over saddle cross slide, turret lathes $6\frac{1}{8}"$
 Center Distance 23" and 35"

THREADS AND FEEDS

Quick Change Gear Box and Automatic Apron
 Worm Drive from lead screw spline for Power feeds
 Longitudinal feed .0018" to .1000" per spindle revolution
 Cross feed .25 times longitudinal feed
 Half nut drive from lead screw thread for thread cutting
 Threads 48 selections RH or LH—4 to 224 per inch
 Lead screw diameter and threads per inch— $\frac{7}{8}"$ -8

HEADSTOCK AND SPINDLE

Spindle Bearings: (4) Sealed, Precision Ball Bearings
 Heat-treated and ground steel spindle
 Hole through Spindle: $1\frac{3}{8}"$
 Draw-in Collet Capacity, $1\frac{1}{16}"$
 Spindle Nose diameter and threads per inch: $2\frac{1}{4}"$ -8
 Drive Plate Diameter: 6"
 Spindle Nose Adapter to #2 Morse
 Variable speed drive—Spindle speeds: Direct drive—
 350 to 2000 R.P.M.; with back gears engaged—
 55 to 300 R.P.M.

CROSS SLIDE AND COMPOUND REST, SCREW CUTTING LATHE

Cross Slide Travel: $6\frac{1}{4}"$
 Compound Rest Travel: $2\frac{1}{4}"$
 Compound Rest graduated 90° in both directions
 Tool Post Opening for Tool Holder: $\frac{3}{8}"$ x $\frac{3}{4}"$

CROSS SLIDE, TURRET LATHE

Cross slide travel: $6\frac{5}{8}"$
 Cross slide graduated in thousandths
 Cross feed screw mounted on self lubricating bronze bearings
 Adjustable double tool post with adjustable wedges
 Tool post openings: $\frac{7}{16}"$ x $1\frac{9}{16}"$

BED

Width of bed across ways: $6\frac{1}{16}"$
 Length of bed $43\frac{1}{8}"$ and $55\frac{1}{8}"$
 Precision ground ways, 2 prismatic "V" ways and 2 flat ways

TAILSTOCK

Spindle Travel 4"
 Spindle Graduations $\frac{1}{16}"$
 Morse Taper Center #2
 Tailstock set-over for Taper turning $1\frac{1}{16}"$

PILOT WHEEL TURRET

Distance across flats: $5\frac{1}{4}"$
 Six position, self indexing with adjustable stops
 Turret holes, diameter $\frac{5}{8}"$ regular— $\frac{3}{4}"$ on special order
 Turret holes bored from headstock of lathe
 Maximum stroke of turret— $7\frac{3}{4}"$

UNDERNEATH DRIVE

Ball Bearing Variable Speed

MOTOR AND SWITCH

Use 1 HP, 3-Phase motor 1725 rpm
 Drum type reversing switch furnished

EQUIPMENT INCLUDED WITH SCREW CUTTING LATHE

- 1—Drive Plate } $6"$ for $2\frac{1}{4}"$ -8 spindle
- } $7"$ for L-00 spindle
- 2 60° Centers
- 1 Threading Dial
- 1 Threading Chart
- 1 #2 Morse Taper Adapter Sleeve
- 1 Tool Post and Wrench
- 1 Tailstock Wrench
- 1 Automatic Safety Gear
- 1 Drum Reversing Switch
- 1 Motor Pulley
- Necessary Belts
- Parts List and Instruction Book

DIMENSIONS

Centers	Bed Length	Overall Length	Width	Height
23"	43"	59"	22"	49"
35"	55"	$70\frac{1}{2}"$	22"	49"

SCREW CUTTING LATHES

Lathe No.		Ship Wt. (lbs.)
2525-V	Quick Change, 3-Drawer Cabinet Model, 23" Centers, Variable Speed Drive	1040
2527-V	Quick Change, 3-Drawer Cabinet Model, 35" Centers, Variable Speed Drive	1090
2555-V	Quick Change, Pedestal Cabinet Model, 23" Centers, Variable Speed Drive	1015
2557-V	Quick Change, Pedestal Cabinet Model, 35" Centers, Variable Speed Drive	1075

TURRET LATHES

2535-2-V	Quick Change, Pedestal Cabinet Model, 43" Bed, Pilot Wheel Turret, Variable Speed Drive	1180
2537-2-V	Quick Change, Pedestal Cabinet Model, 55" Bed, Pilot Wheel Turret, Variable Speed Drive	1240
2545-2-V	Quick Change, 3-Drawer Cabinet Model, 43" Bed, Pilot Wheel Turret, Variable Speed Drive	1200
2547-2-V	Quick Change, 3-Drawer Cabinet Model, 55" Bed, Pilot Wheel Turret, Variable Speed Drive	1250

IMPORTANT

To obtain maximum performance from the Logan 12" Lathe either purchase No. 1120 1 HP, 3 phase motor with the lathe or send us your own motor for installation on a cost basis in the lathe so that we can dynamically balance the complete unit. If a lathe is ordered less motor, a \$25.00 charge will be made for installing a motor for final inspection of the lathe and the motor removal prior to shipment.

Logan 11"

SWING LATHES

- 1 1/16" COLLET CAPACITY
- 1 3/8" SPINDLE BORE
- 24" and 36" CENTERS
- 16-SPEED V-BELT DRIVE

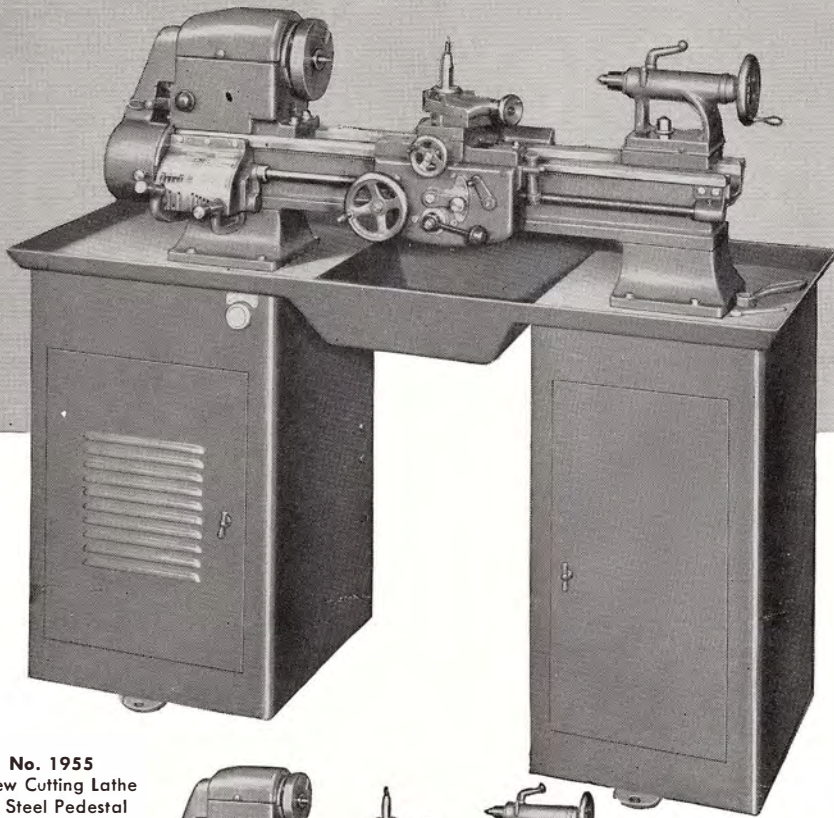

No. 1955
Screw Cutting Lathe
on Steel Pedestal
Cabinet Base

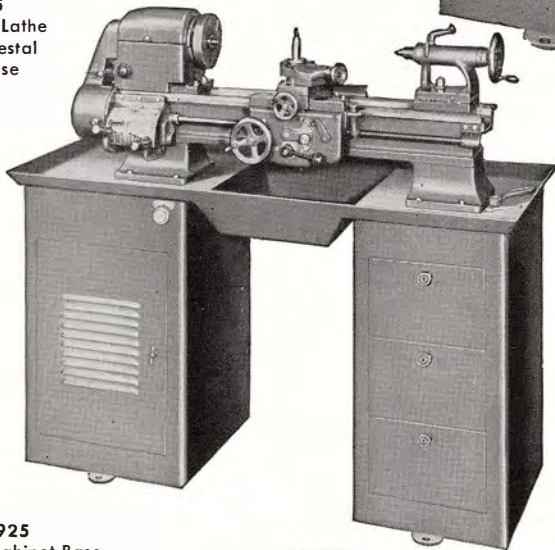

No. 1925
on 3-Drawer Cabinet Base

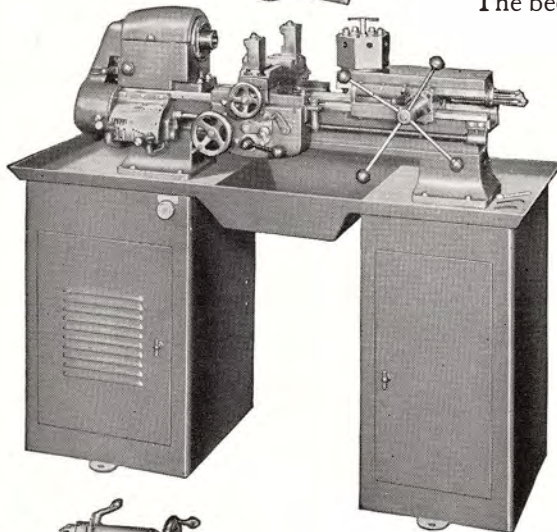

No. 1935-2
on Pedestal Cabinet Base



No. 1920
Floor Mounted Model
with Legs and Pan

These 11" swing Logans have the ruggedness and sustained accuracy to fill a definite need in both industrial and school shops. The advanced design features include a ball bearing spindle that needs no adjustment for any speed within its wide range. The Automatic Apron with lever-operated, disc type clutch moves over a rugged bed with its two V-ways and two flat ways precision ground. Ruggedly proportioned as well as precision built, these 11" Logans are accurate when you set them up and still accurate after years of use. All cabinet models have three enclosed compartments or drawers for convenient tool and work storage.

The bed is furnished flame hardened at small extra cost.

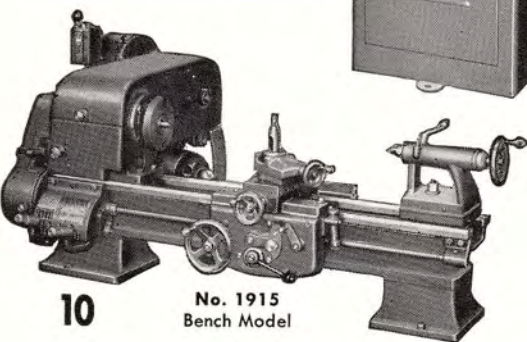

No. 1915
Bench Model

CAPACITY OF LATHE

Swing over bed.....11 1/8"
 Swing over saddle cross slide, screw cutting lathes...6 7/8"
 Swing over saddle cross slide, turret lathes.....4 1/2"

THREADS AND FEEDS

Quick change gear box and automatic apron
 Worm drive from lead screw spline for power feeds
 Friction clutch on power feeds
 Longitudinal feed .0018" to .1000" per spindle revolution
 Cross feed .25 times longitudinal feed
 Half nut drive from lead screw thread for thread cutting
 Threads—48 selections RH or LH—4 to 224 per inch
 Lead screw diameter and threads per inch 3/4"-8

BED

Width of bed across way.....6 15/16"
 Length.....43 1/8" and 55 1/8"
 Precision ground ways; 2 prismatic "V" ways and 2 flat ways

HEADSTOCK AND SPINDLE

Spindle Bearings: Sealed Ball Bearings, precision type with preloading
 Heat-treated and ground steel spindle
 Hole through spindle—1 3/8"
 Draw-in collet capacity.....1 1/16"
 Spindle Nose Diameter and threads per inch: 2 1/4"-8
 Width of face of bull gear and back gears: 3/4"
 Drive plate diameter: 6"
 16 Spindle Speeds (Floor and Bench Models)
 direct drive:—325, 385, 470, 535, 885, 1020, 1230 and 1430 rpm.
 back gears:—50, 62, 75, 90, 145, 170, 200 and 235 rpm.
 16 Spindle Speeds (3-Drawer Cabinet and Pedestal Base Models)
 direct drive:—230, 315, 410, 560, 600, 820, 1070 and 1450 rpm.
 back gears:—40, 50, 65, 95, 100, 135, 180 and 240 rpm.

CROSS SLIDE AND COMPOUND REST, SCREW CUTTING LATHE

Cross Slide Travel 6 1/4"
 Cross Slide graduated in thousandths
 Cross feed screw mounted on self-lubricating bronze bearings
 Compound Rest Travel 2 1/4"
 Compound rest graduated in thousandths
 Compound swivel graduated 90° in both directions
 Tool post opening for tool holder shank 3/8" x 3/4"

CROSS SLIDE, TURRET LATHE

Cross Slide Travel 6"
 Cross Slide graduated in thousandths
 Cross feed screw mounted on self-lubricating bronze bearings
 Adjustable double tool post with adjustable wedges
 Tool post slots 7/16" x 1 9/16"

TAILSTOCK

Spindle Travel: 4"
 Spindle Graduations: 1/16"
 Morse Taper center: No. 2
 Tailstock set-over for taper turning: 1 1/16"

PILOT WHEEL TURRET

Distance across flats 5 1/4"
 Six position, self indexing with adjustable stops
 Turret holes, diameter 5/8" regular—3/4" on special order
 Turret holes bored from headstock of lathe
 Maximum stroke of turret—7 3/4"

COUNTERSHAFT ASSEMBLY—FLOOR AND BENCH MODELS

All "V" belt drive
 Two step motor pulley—Four step countershaft pulley
 Countershaft mounted on ball bearings
 Adjustable motor mounting bracket
 Countershaft assembly independently supported on patented 3 point suspension
 Countershaft assembly completely insulated with rubber to prevent vibration being transmitted to lathe
 Countershaft and all pulleys completely enclosed and guarded
 Automatic belt tension release when guard for cone pulleys is raised to change belt steps

UNDERNEATH DRIVE (Cabinet Models)

Two step motor pulley to countershaft drive, B section V-belt, Belt size, 40" x 5/8"
 Four step countershaft to jackshaft drive, B section V-belt, Belt size, 30" x 5/8"
 Double V-belt drive, Jackshaft to spindle, A section V-Belts, Belt sizes, 49" x 1/2"
 Jackshaft and countershaft mounting—Ball Bearing

MOTOR

3/4 HP Ball Bearing, 1725 RPM Motor is recommended
 If lathe is ordered without motor, specify bore of motor pulley to be furnished with lathe

EQUIPMENT INCLUDED WITH SCREW CUTTING LATHE

- 1 Drive Plate
- 2 60° Centers
- 1 Threading Dial
- 1 Threading Chart
- 1 Drum Reversing Switch
- 1 Automatic Safety Gear
- 1 Spindle Nose Taper Adaptor No. 2 M.T.
- 1 Tailstock Wrench
- 1 Tool Post and Wrench
- 1 Motor Pulley
- Parts List and Instruction Book
- Necessary Belts

DIMENSIONS

Centers	Bed Length	Overall Length	Width	Height
Floor Models				
24"	43"	54"	30"	48 1/2"
36"	55"	66"	30"	48 1/2"
Bench Models				
24"	43"	45"	30"	21"
36"	55"	57"	30"	21"
Cabinet Models				
24"	43"	59"	21"	48 3/4"
36"	55"	70 1/2"	21"	48 3/4"

SCREW CUTTING LATHES

Lathe No.	Description	Ship. Wt. (Lbs.)
1915	Quick Change, Bench Model, 24" Centers, V-Belt Drive	505
1917	Quick Change, Bench Model, 36" Centers, V-Belt Drive	550
1920	Quick Change, Floor Model, 24" Centers, V-Belt Drive	615
1922	Quick Change, Floor Model, 36" Centers, V-Belt Drive	665
1925	Quick Change, 3-Drawer Cabinet Model, 24" Centers, V-Belt Drive	870
1927	Quick Change, 3-Drawer Cabinet Model, 36" Centers, V-Belt Drive	915
1955	Quick Change, Pedestal Cabinet Model, 24" Centers, V-Belt Drive	840
1957	Quick Change, Pedestal Cabinet Model, 36" Centers, V-Belt Drive	890
1975	Same as 1955 except with L00 Spindle and 22" centers	850
1977	Same as 1957 except with L00 Spindle and 34" centers	900
1985	Same as 1925 except with L00 Spindle and 22" centers	880
1987	Same as 1927 except with L00 Spindle and 34" centers	925

TURRET LATHES

1935-2	Quick Change, Pedestal Cabinet Model, 43" Bed, Pilot Wheel Turret, V-Belt Drive	905
1937-2	Quick Change, Pedestal Cabinet Model, 55" Bed, Pilot Wheel Turret, V-Belt Drive	955
1940-2	Quick Change, Floor Model, 43" Bed, Pilot Wheel Turret, V-Belt Drive	680
1942-2	Quick Change, Floor Model, 55" Bed, Pilot Wheel Turret, V-Belt Drive	730
1945-2	Quick Change, 3-Drawer Cabinet Model, 43" Bed, Pilot Wheel Turret, V-Belt Drive	930
1947-2	Quick Change, 3-Drawer Cabinet Model, 55" Bed, Pilot Wheel Turret, V-Belt Drive	980

NOTE: If a cabinet model lathe is ordered less motor, a \$25.00 charge will be made for installing a motor for final inspection of the lathe and the motor removal prior to shipment.

Logan 10" SWING LATHES

- 1/2" COLLET CAPACITY
- 25/32" SPINDLE BORE
- 24" CENTERS



No. 1825
Screw Cutting Lathe on
3-Drawer Cabinet Base

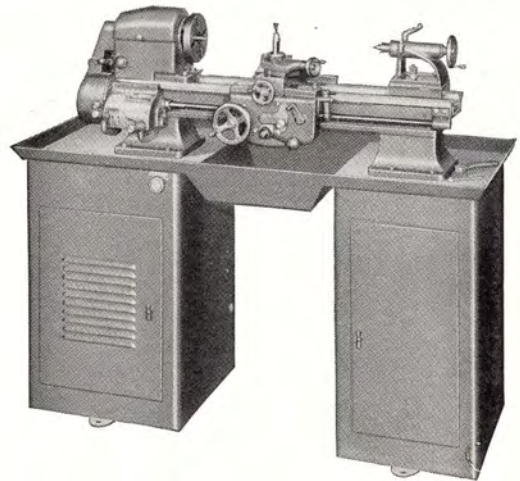

No. 1875
Screw Cutting Lathe
on Pedestal Cabinet Base

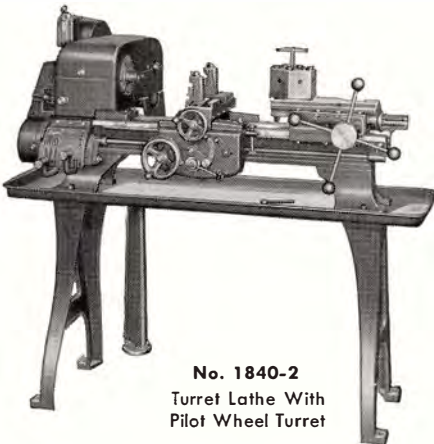

No. 1840-2
Turret Lathe With
Pilot Wheel Turret

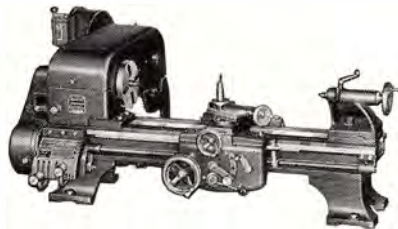

No. 1815
Quick Change Gear
Bench Model Lathe

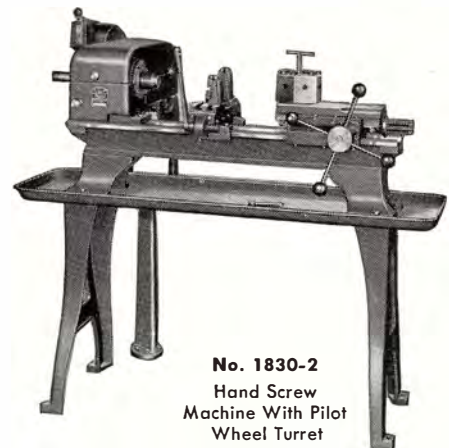

No. 1830-2
Hand Screw
Machine With Pilot
Wheel Turret

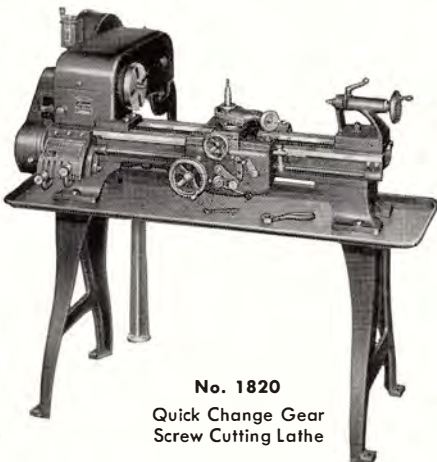

No. 1820
Quick Change Gear
Screw Cutting Lathe

For industry's great variety of medium and small lathe turning operations, these 10" swing Logans are tools of proven accuracy and economy. In school shops they have been the training tools of many of today's top flight metal workers. In advanced design features these 10" swing lathes match the larger Logan models. They have the Logan ball bearing spindle, V-belt drive, the Automatic Apron, and the precision ground, 2-V-way, 2-flat-way bed. Their versatility is increased by the complete line of accessories and attachments listed in the following section of this catalog. Their sustained accuracy and low cost performance is in the records of well run shops. Rugged, precision ground, 2-V-way, 2-flat-way beds furnished flame hardened at only small added cost.

CAPACITY OF LATHE

Swing over bed.....10 $\frac{1}{2}$ "
 Swing over saddle cross slide—screw cutting lathes...6 $\frac{1}{8}$ "
 Distance between centers.....24"
 Swing over saddle cross slide, turret lathe.....4 $\frac{1}{2}$ "

THREADS AND FEEDS

Quick change gear box and automatic apron
 Worm drive from lead screw spline for power feeds
 Friction clutch on power feeds
 Longitudinal feed .0018" to .1000" per spindle revolution
 Cross feed .25 times longitudinal feed
 Half nut drive from lead screw thread for thread cutting
 Threads—48 selections RH or LH—4 to 224 per inch.
 Lead screw diameter: $\frac{3}{4}$ "—8 thread

BED

Width of bed across ways.....6 $\frac{1}{16}$ "
 Bed Length.....43 $\frac{3}{8}$ "
 Precision ground ways; 2 prismatic "V" ways and 2 flat ways.

HEADSTOCK AND SPINDLE

Front bearing—double row ball bearing
 Rear bearing—single row ball bearing
 Hole through spindle.....2 $\frac{5}{16}$ "
 Draw-in collet capacity..... $\frac{1}{2}$ "
 Drive plate diameter.....6"
 Morse Taper with adaptor, No. 3—No. 2
 Size of centers used, Morse Taper No. 2
 Spindle nose diameter and threads per in. 1 $\frac{1}{2}$ "-8
 Number of spindle speeds (except No. 1825 and No. 1875).....12
 Number of spindle speeds (No. 1825 and No. 1875).....16
 Spindle Speeds (all 10" lathes except No. 1825 and 1875)
 direct drive:—330, 425, 550, 880, 1100, and 1430 rpm.
 back gears:—55, 70, 90, 145, 185, and 240 rpm.
 Spindle Speeds (for No. 1825 and 1875 cabinet model only)
 direct drive:—230, 315, 410, 560, 600, 820, 1070 and 1450 rpm.
 back gear drive:—40, 50, 65, 95, 100, 135, 180 and 240 rpm.

CROSS SLIDE AND COMPOUND REST, SCREW CUTTING LATHE

Cross slide graduated in thousandths—Travel.....6 $\frac{1}{4}$ "
 Compound rest top slide graduated in thousandths—
 Travel.....2 $\frac{1}{4}$ "
 Compound rest swivel—graduated 90° in both directions
 Tool post opening for tool holder..... $\frac{3}{8}$ x $\frac{3}{4}$ "

CROSS SLIDE, TURRET LATHE

Cross slide travel: 6"
 Cross slide graduated in thousandths

Cross feed screw mounted on self lubricating bronze bearings
 Adjustable double tool post with adjustable wedges
 Tool post slots: $\frac{1}{16}$ " x 1 $\frac{9}{16}$ "

TAILSTOCK

Spindle travel.....2 $\frac{3}{8}$ "
 Spindle graduations..... $\frac{1}{16}$ "
 Morse Taper center.....No. 2
 Tailstock set over for taper turning.....1 $\frac{1}{16}$ "

PILOT WHEEL TURRET

Distance across flats: 5 $\frac{1}{4}$ "
 Six position, self indexing with adjustable stops
 Turret holes, diameter $\frac{5}{8}$ " regular— $\frac{3}{4}$ " on special order
 Turret holes bored from headstock of lathe
 Maximum stroke of turret—7 $\frac{3}{4}$ "

COUNTERSHAFT ASSEMBLY (Floor or Bench Models)

All "V" belt drive
 Two step motor pulley—Three step countershaft pulley
 Countershaft mounted on ball bearings
 Adjustable motor mounting bracket
 Countershaft assembly completely insulated with rubber to prevent vibration being transmitted to lathe
 Countershaft and all pulleys completely enclosed and guarded
 Automatic belt tension release when guard for cone pulleys is raised

UNDERNEATH DRIVE (Cabinet Models)

Two step motor pulley to countershaft drive.
 B Section V-belt, Belt size, 40" x $\frac{5}{8}$ "
 Four step countershaft to jackshaft drive.
 B section V-belt, Belt size, 30 x $\frac{5}{8}$ "
 Double V-belt drive, Jackshaft to spindle.
 A section V-belts, Belt sizes, 49" x $\frac{1}{2}$ "
 Jackshaft and countershaft mounting—Ball bearing

MOTOR

Use $\frac{1}{2}$ H.P. 1725 R.P.M. motor

EQUIPMENT WITH SCREW CUTTING LATHES

1 6" Drive Plate	1 No. 3—No. 2 Morse Taper Adaptor
2 60° Centers	1 Tool Post and Wrench
1 Threading Dial	1 Tailstock Wrench
1 Threading Chart	1 Motor Pulley
1 Drum Reversing Switch	Parts List and Instruction Book
Necessary Belts	

(Automatic Safety Gear furnished with 1825 and 1875 models only)

OVERALL DIMENSIONS

	Overall		
	Length	Width	Height
Model 1815	45"	30"	21"
Model 1820, 1830-2, 1840-2	54"	30"	48 $\frac{1}{2}$ "
Model 1825, 1835-2, 1845-2, 1875	59"	20 $\frac{1}{2}$ "	48"

Lathe No.

SCREW CUTTING LATHES

Ship. W. (Lbs)

1815	Quick Change, Bench Model, 24" Centers, V-Belt Drive.....	435
1820	Quick Change, Floor Model, 24" Centers, V-Belt Drive.....	594
1825	Quick Change, 3-Drawer Cabinet Model, 24" Centers, V-Belt Drive.....	790
1875	Quick Change, Pedestal Cabinet Model, 24" Centers, V-Belt Drive.....	765

TURRET LATHES

1830-2	Hand Screw, Floor Model, 43" Bed, Pilot Wheel Turret, V-Belt Drive.....	550
1835-2	Quick Change, Pedestal Cabinet Model, 43" Bed, Pilot Wheel Turret, V-Belt Drive.....	830
1840-2	Quick Change, Floor Model, 43" Bed, Pilot Wheel Turret, V-Belt Drive.....	600
1845-2	Quick Change, 3-Drawer Cabinet Model, 43" Bed, Pilot Wheel Turret, V-Belt Drive.....	855

NOTE: If a cabinet model lathe is ordered less motor, a \$25.00 charge will be made for installing a motor for final inspection of the lathe and the motor removal prior to shipment.

Logan 9" SWING LATHES

- 28" or 17" Between Centers
- 1/2" Collet Capacity
- 25/32" Spindle Hole
- Quick or Plain Change Gears
- Automatic or Plain Apron

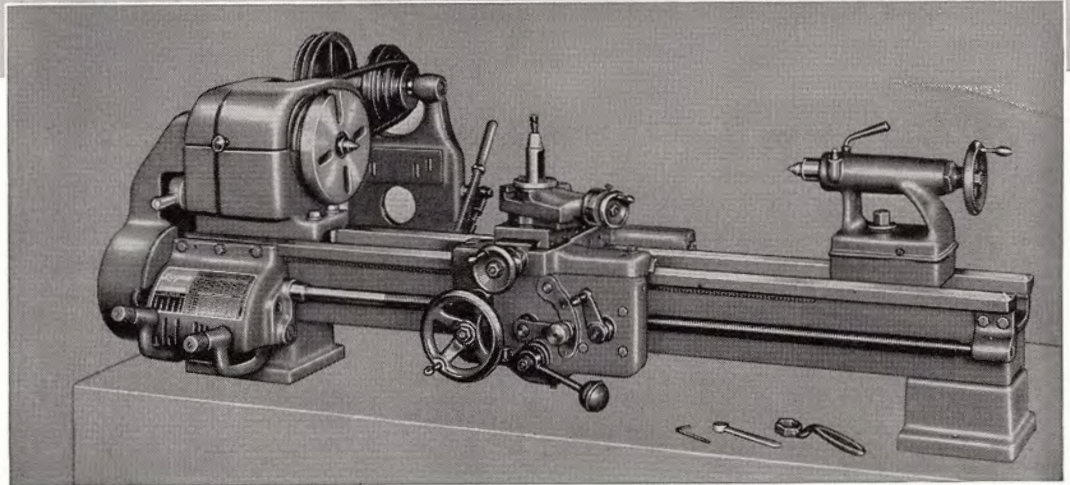

No. 9B28-1 Quick Change Gears, Automatic Apron

FOR situations where a smaller lathe is indicated, here is the sustained accuracy inherent in Logan advanced design. In addition to their accuracy, these No. 9B series lathes combine remarkable work capacity and versatility. Ball bearing spindles provide a range of 55 to 1450 rpm without adjustment and permit full use of high speed cutting tools. Ruggedly proportioned throughout, they take heavy cuts smoothly. On small work in machine shops, tool rooms and manufacturing these lathes can be depended upon for precision results. For the farm and home work shop they provide professional standards of performance with the utmost economy.

Four Models with 28" Centers	
Lathe No.	Ship. Wt. (Lbs.)
No. 9B28-1 Quick Change Gears, Automatic Apron	310
No. 9B28-21 Quick Change Gears, Plain Apron	300
No. 9B28-41 Plain Change Gears, Automatic Apron	300
No. 9B28-61 Plain Change Gears, Plain Apron	290

Four Models with 17" Centers	
Lathe No.	Ship. Wt. (Lbs.)
No. 9B17-1 Quick Change Gears, Automatic Apron	285
No. 9B17-21 Quick Change Gears, Plain Apron	275
No. 9B17-41 Plain Change Gears, Automatic Apron	275
No. 9B17-61 Plain Change Gears, Plain Apron	265
No. LA12-2 Threading Dial, Ship. Wt. 3 lbs.	

No. AC-115 Drum Reversing Switch, Switch Box and 30" Rubber Covered Cable. Shpg. Wt. 2 lbs.

S P E C I F I C A T I O N S

CAPACITY OF LATHE

Swing over bed.....	9 ¹ / ₄ "
Swing over cross slide.....	5"
Distance between centers.....	28" or 17"

THREADS AND FEEDS

Reversible power longitudinal feed.
 Reversible power cross feed (on Automatic Apron Only).
 Threads—48 selections RH or LH
 4 to 224 per inch
 Crossfeed—.25 times longitudinal feed
 (on Quick Change Models)

BED

Width of Bed.....	6 ¹ / ₁₆ "
Bed length	44" or 33"
Precision ground ways. 2 prismatic "V" ways and 2 flat ways.	

HEADSTOCK AND SPINDLE

Spindle mounted on greased-sealed ball bearings preloaded in the headstock at the factory.
 Morse Taper with adapter No. 3, No. 2.
 Back gear shaft bearings—self-lubricating bronze bearings.
 Size of centers used. Morse Taper No. 2.
 Hole thru spindle.....2⁵/₃₂"
 Spindle nose diameter and threads per inch1¹/₂"-8
 V-belt cone pulley for "A" cross section.
 V-belts 1/2" wide, 9/32" thick.
 Number of spindle speeds.....12
 Spindle speeds, back gears engaged: 55, 80, 112, 144, 200 and 253 R.P.M.
 Spindle speeds, direct belt driven, 353, 459, 645, 831, 1157 and 1450 R.P.M.

TAILSTOCK

Spindle travel	2 ³ / ₈ "
Spindle graduations	1/16"
Morse taper center.....	No. 2
Tailstock top sets over for taper turning 1/2".	

CARRIAGE AND CROSS SLIDE

Cross slide graduated in thousandths, travel5¹/₂"
 Cross feed screw mounted on self-lubricating bronze bearings.
 Compound rest swivel—graduated 90° in both directions.
 Tool post opening for tool holder shank3/8 x 3/4"
 Size of cutter bits used.....1/4" Sq.

COUNTERSHAFT ASSEMBLY

2 speed "V" motor pulley.....2³/₈-27/8"
 2 speed "V" countershaft pulley...6"-6³/₈"
 30" x 1/2" "V" belt from motor to countershaft.
 44" x 1/2" "V" belt—countershaft to headstock.
 3 steps "V" belt cone pulley mounted on countershaft.
 Countershaft mounted on self lubricating bronze bearings.
 Motor mounted directly on countershaft bracket.
 Countershaft mounted on bench independent of lathe.

LATHE EQUIPMENT

- 1—6" Drive Plate
- 1—No. 3-No. 2 Morse taper adapter
- 1—Tool post and wrench
- 1—Motor pulley
- 2—60° centers
- 1—Threading chart
- 1—Tailstock Wrench
- Necessary Belts
- Parts List and Instruction Book

OVERALL DIMENSIONS

(including Countershaft Assembly)
 (28" Centers) 50" long, 28" wide, 15¹/₂" high
 (17" Centers) 39" long, 28" wide, 15¹/₂" high

MOTOR

Use 1/3 or 1/2 H.P. 1725 R.P.M. Motor—Suitable for sidewall mounting. If lathe is ordered without motor, specify either 1/2" or 5/8" bore of motor pulley to be furnished with lathe.

CHUCKS AND ACCESSORIES

3-JAW UNIVERSAL CHUCKS

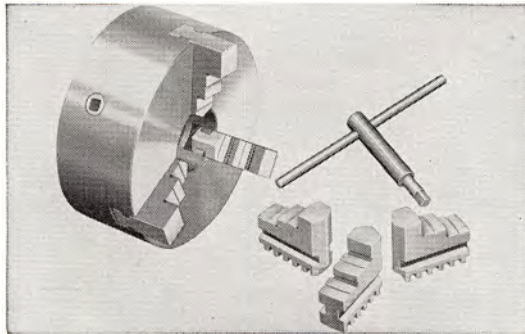

Furnished with two sets of jaws, one set for inside chucking and the other for outside chucking. Jaws are automatically self centering. Complete with threaded back plate except No. 536 and 531, on which the body of the chuck itself is threaded. When ordered with a lathe, chuck is fitted to the lathe.

Cat. No.	Chuck Size	Fitted for Spindle	Logan Lathe Size	Ship. Wt. Lbs.
536	5" Med. Duty	1 1/2"-8 thd.	9"-10"	10
531	5" Hvy. Duty	1 1/2"-8 thd.	9"-10"	12
1063/AC-108	6" Hvy. Duty	1 1/2"-8 thd.	9"-10"	22
1063/AC-105	6" Hvy. Duty	2 1/4"-8 thd.	11"-12"-14"	23
1063/2300	6" Hvy. Duty	L-00	11"-12"-14"	23

4-JAW INDEPENDENT CHUCKS

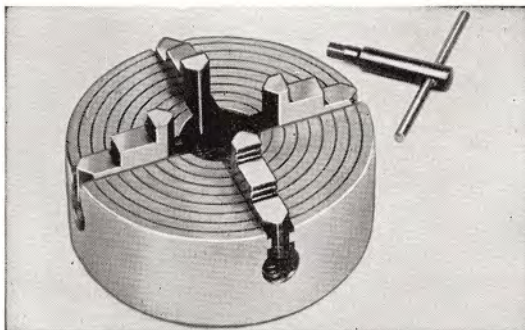

Jaws are independently adjusted and are reversible. The body of No. 444 Chuck is threaded. All other independent chucks are furnished with threaded back plates fitted for the lathe spindle.

Cat. No.	Chuck Size	Fitted for Spindle	Logan Lathe Size	Ship. Wt. Lbs.
444	6" Med. Duty	1 1/2"-8 thd.	9"-10"	13
1064/AC-126	6" Hvy. Duty	1 1/2"-8 thd.	9"-10"	20
1064/AC-117	6" Hvy. Duty	2 1/4"-8 thd.	11"-12"-14"	21
1064/2303	6" Hvy. Duty	L-00	11"-12"-14"	21
1284/AC-117	8" Hvy. Duty	2 1/4"-8 thd.	11"-12"-14"	27
1284/2303	8" Hvy. Duty	L-00	12"-14"	27
1308-LO	8" Hvy. Duty	L-00	14"	38
1310/6313	10"	2 1/4"-8 thd.	14"	70
1310/2306	10"	L-00	14"	70
1310/6836	10"	L-00	14"	70

JACOBS COMMUTATOR CHUCK KIT

Contains a Jacobs Armature Driving Chuck, 1/4 to 3/4" capacity, and a Center Rest Chuck also 1/4 to 3/4" capacity. Both chucks equipped with No. 2 Morse Taper Arbors to fit the headstock and tailstock.

No. 459 Shipping wt. 9 lbs.

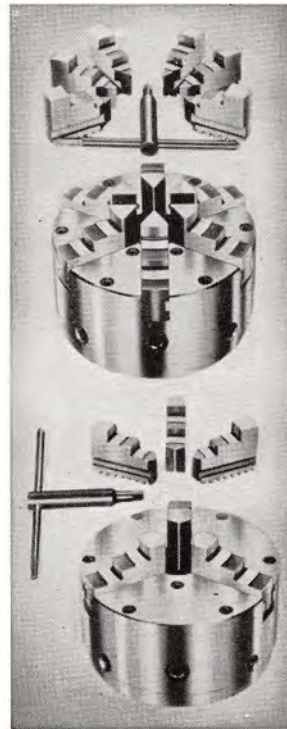

6-JAW BUCK AJUST-TRU CHUCKS

The 6-jaw Buck chuck replaces both collets and step collets. Spindle hole capacity from 1/8" to 1 1/2" and step jaw capacity from 1/8" to 5". All told this single chuck handles the work of 93 collets. Accuracy and speed of operation is the same as for the 3-jaw Ajust-tru chucks.

Cat. No.	Chuck Size	Fitted for Spindle	Logan Lathe Size	Ship. Wt. Lbs.
3662/AC-113	6"	1 1/2"-8 thd.	9"-10"	36
3662/AC-114	6"	2 1/4"-8 thd.	11"-12"-14"	36
3662/2305	6"	L-00	11"-12"-14"	36

3-JAW BUCK AJUST-TRU CHUCKS

These chucks have the accuracy of 4-jaw chucks plus the speed and versatility of universal chucks. Work can be chucked to .0005" precision in one minute, and duplicate parts can be re-chucked with the same accuracy with no further adjustment. They eliminate most needs for stub arbors, mandrels, and special fixtures.

Cat. No.	Chuck Size	Fitted for Spindle	Logan Lathe Size	Ship. Wt. Lbs.
3634/AC-113	6"	1 1/2"-8 thd.	9"-10"	35
3634/AC-114	6"	2 1/4"-8 thd.	11"-12"-14"	35
3634/2305	6"	L-00	11"-12"-14"	35
4733/6385	7 1/2"	2 1/4"-8 thd.	11"-12"-14"	44
4733/2301	7 1/2"	L-00	12"-14"	44
4733/6833	7 1/2"	L-00	14"	44
6309/6311	9"	2 1/4"-8 thd.	14"	88
6309/2302	9"	L-00	14"	88
6309/6834	9"	L-00	14"	88

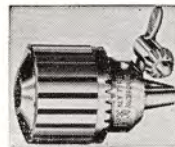

JACOBS DRILL CHUCKS

No. 451 0-1/2" cap. Requires No. 447 or 445 Arbor. Ship. wt. 2 1/2 lbs.
 No. 452 3/16"-3/4" cap. Requires No. 448 or 446 Arbor. Ship. wt. 3 1/2 lbs.



JACOBS CENTER REST CHUCK

1/4"-3/4" capacity. Requires No. 448 or 446 Arbor.
 No. 455 Shipping wt. 2 lbs.

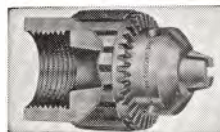

JACOBS HEADSTOCK CHUCKS

No. 453 1/8"-5/8" capacity. For 1 1/2"-8 thread spindle. Ship. wt. 3 1/2 lbs.
 No. 454 3/16"-3/4" capacity. For 1 1/2"-8 thread spindle. Ship. wt. 4 1/2 lbs.



CHUCK ARBORS

No. 445 No. 3 M.T. for No. 451 Jacobs Chuck. Shipping wt. 1 lb.
 No. 446 No. 3 M.T. for No. 452 and 455 Jacobs Chucks. Ship. wt. 1 lb.
 No. 447 No. 2 M.T. for No. 451 Jacobs Chuck. Shipping wt. 1 lb.
 No. 448 No. 2 M.T. for No. 452 and 455 Jacobs Chucks. Ship. wt. 1 lb.

CHUCK ADAPTERS (Semi-Finished)

Cat. No.	Threaded	Chuck No. Chuck Diam.	Wt.	Cat. No.	Threaded	Chuck No. Chuck Diam.	Wt.
AC-101	1 1/2"-8 thd.	5"	4 lbs.	2303	L-00	1064, 1284	5 lbs.
AC-104	1 1/2"-8 thd.	6"	7 lbs.	2305	L-00	3634, 3662	6 lbs.
AC-105	2 1/4"-8 thd.	1063	5 lbs.	2306	L-00	1310	7 lbs.
AC-107	2 1/4"-8 thd.	6"	7 lbs.	6311	2 1/4"-8 thd.	6309	8 lbs.
AC-108	1 1/2"-8 thd.	1063	5 lbs.	6313	2 1/4"-8 thd.	1310	6 lbs.
AC-113	1 1/2"-8 thd.	3634, 3662	5 lbs.	6385	2 1/4"-8 thd.	4733	8 lbs.
AC-114	2 1/4"-8 thd.	3634, 3662	5 lbs.	6833	L-00	4733	9 lbs.
AC-117	2 1/4"-8 thd.	1064, 1284	5 lbs.	6834	L-00	6309	13 lbs.
AC-126	1 1/2"-8 thd.	1064	5 lbs.	6836	L-00	1310	9 lbs.
2300	L-00	1063	6 lbs.				
2301	L-00	4733	9 lbs.				
2302	L-00	6309	15 lbs.				

COLLETS, COLLET ATTACH

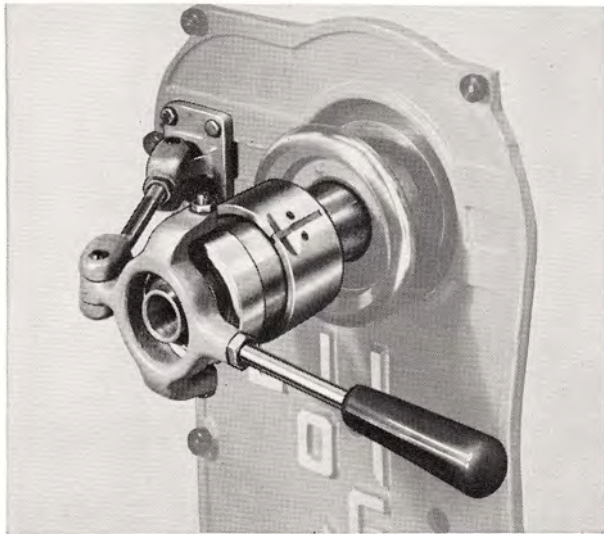

PRODUCTION COLLET ATTACHMENTS

Hand lever type draw-in collet chuck opens and closes while lathe spindle is in motion. Fast and accurate for production work. Bar stock may be hand fed through lathe spindle. In addition to closing mechanism and hollow draw bar, a spindle nose cap, closing sleeve and wrench are furnished.

Cat. No.	For Lathe	Collet Used	Max. Collet Capacity	Ship Wt. Lbs.
AC-166	800 and 1800 series	AC-30	1/2"	12
AC-360-3	11" lathes serial #52576 and over	475	1 1/16"	18
2744	12" lathes serial #68249 and over, threaded spindle	475	1 1/16"	22
2743	12" lathes with L-00 spindle	475	1 1/16"	23
8000	14" lathes up to serial #81143 threaded spindle	475	1 1/16"	30
8004	14" lathes serial #81143 and over, threaded spindle	475	1 1/16"	30
8001	14" lathes up to serial #81005 L00 spindle	475	1 1/16"	32
8005	14" lathes serial #81005 and over, L00 spindle	475	1 1/16"	32
8152	14" lathes with L-0 spindle	475	1 1/16"	32

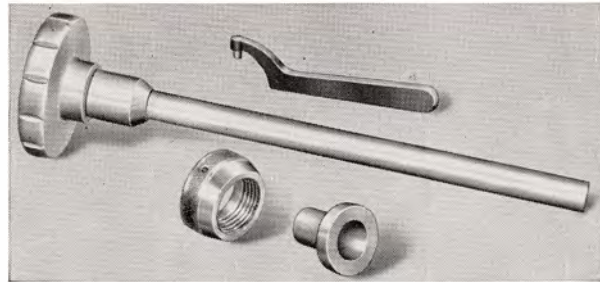

DRAW-IN COLLET CHUCK ATTACHMENTS

All attachments consist of hollow draw bar, tapered closing sleeve, spindle nose cap and spindle cap wrench.

Cat. No.	For Lathe Size	Collet Used	Max. Collet Capacity	Ship. Wt. Lbs.
AC-251	9"	AC-30	1/2"	4
AC-152	10"	AC-30	1/2"	5
LA-1050-1	11" lathes serial #52576 and over	475	1 1/16"	8
2380	12" lathes serial #68249 and over, threaded spindle	475	1 1/16"	11
2390	12" lathes with L00 spindle	475	1 1/16"	12
6300	14" lathes up to serial #81143, threaded spindle	475	1 1/16"	12
8006	14" lathes serial #81143 and over, threaded spindle	475	1 1/16"	12
6340	14" lathes up to serial #81005, L00 spindle	475	1 1/16"	13
8007	14" lathes serial #81005 and over, L00 spindle	475	1 1/16"	13

HEAVY DUTY COOLANT PUMP

High Pressure—
Gear Type

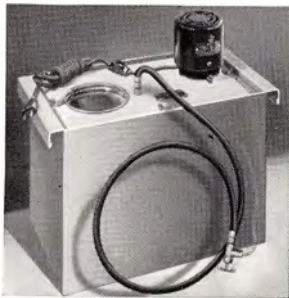

Light weight, portable. Operates independently of the machine tool. Delivers from 90 gallons per hour to a few drops. 20 lbs. pressure capacity. 1/25 H.P., 115 V., AC 60 Cy. 1 phase Motor. 7 1/2 gallon container has 5" bowl screen strainer. Includes 4 ft. of 3/8" Neoprene hose with flow control pet cock and 12" of flexible feed spout. 5 1/2 ft. of rubber-covered electric cord with plug and motor switch.

No. 525-2 Ship. wt., 38 lbs.

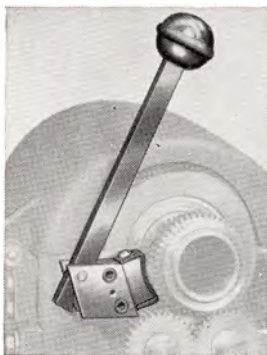

SPINDLE BRAKE

Fits any Logan 11" Swing Lathe. Replaceable leather shoe applies friction to spindle for rapid brake. Spring return lever.

No. AC-325 Spindle brake with screws for attaching. Shipping weight, 10 lbs.

METAL SPINNING ATTACHMENT

Equips any 10", 11" or 12" Logan Lathe for metal spinning operations. Rest is 10 inches long. Easily attached to or detached from the lathe.

No. AC-385 Shipping wt., 17 lbs.



PALMGREN MILLING ATTACHMENT

Mounted in 10 seconds on any tool post up to 1 1/2" diameter. Fits Logan 9", 10", 11" and 12"

Lathes. Allows lathe to be used for slotting, milling, sawing, grooving, squaring, recessing, etc. Jaws are 2 1/2" wide, 1 1/16" deep, and open to 2 1/2".

No. 250 Shipping weight, 14 lbs.



LEVER-MATIC COLLET CHUCK WITH CO-NETIC COLLET

Easily mounted directly on the threaded spindle nose, the Lever-Matic "runs as true as the spindle." Finger tip grip control provides a tremendously powerful grip for tough steel under a heavy cut, or a firm, yet gentle grip on tubing. Takes maximum bar stock capacity of the spindle. Permits internal and external chucking by hand lever or air cylinder. Runs cool. Provides quickest, easiest collet and arbor changes. Precision built from high grade steel.

The Co-Netic Collet used with the Lever-Matic has a full-floating, self-aligning action in each jaw, assuring uniform pressure over end, tire length.



Lever-Matic Sizes

Cat. No.	Collet Capacity	Lathes Fitted (or Spindle Fitted)	Ship. Wt. (lbs.)
100	1"	Logan 9", 10"	19
150	1 1/2"	Logan 11", 12", 14"	41
150-L	1 1/2"	For L-100 Spindle	41
		Fits 11", 12" and 14" Logan Lathes with L-00 Spindle	
150-LO	1 1/2"	14" Lathe LO	41

Co-Netic Collets

Cat. No.	Size	Lever-Matic Chuck Fitted	Ship. Wt. (lbs.)
110	1/8" to 1" by 32nds	No. 100	1
160	1/4" to 1 1/2" by 32nds	No. 150, 150-L, and 150-LO	2

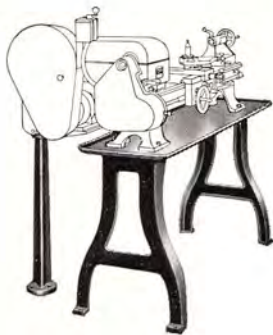

SETS FOR CONVERSION OF BENCH MODELS TO FLOOR MODELS

Each set includes Pan, Legs and Countershaft support

No. LA-1072 1 1/2" Deep Oil Pan, for 10" and 11" Lathes, 24" Centers Ship Wt., 128 lbs.

No. LA-1078 1 1/2" Deep Oil Pan, for 11" Lathes, 36" Centers. Ship. wt., 130 lbs.

No. 7025 MARK O-A PIVOT TYPE LATHE TRACER ATTACHMENT (Specify size of Logan Lathe)

COLLET RACKS

Clamp to rear way of Logan Lathe bed. Provide convenient storage and protection for collets.

No. AC-340 for AC-30 Collets on 9" and 10" Lathes. Ship. wt., 7 lbs.

No. AC-350 for AC-50 Collets on 10" Lathes. Ship. wt., 7 lbs.

No. AC-345 for No. 475 Collets on 11" and 12" Lathes. Ship. wt., 7 lbs.

No. 6325 for No. 475 Collets on 14" Lathes. Ship. wt., 7 lbs.

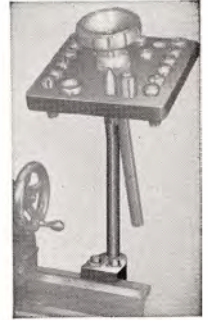

DRAW-IN COLLETS

No. AC-30 Sizes 1/16" to 1/2" by 32ds. Round. Ship. wt., 1/2 lb.

No. AC-35-S Set of 15 #AC-30 Collets, 1/16" to 1/2" by 32ds. Ship. wt. 7 lbs.

No. 475 Sizes 1/16" to 1 1/16" by 32ds. Round. Ship. wt. 3/4 lb.

No. 476-S Set of 16 #475 Collets, 1/16" to 1" by 16ths. Ship. wt. 9 lbs.

No. 477-S Set of 31 #475 Collets, 1/16" to 1" by 32ds. Ship. wt. 18 lbs.



PUSH TYPE COLLETS

No. AC-50 Used with LA-32-34 Bar Feed on Hand Screw Machines only. Sizes 1/16" to 5/8" by 32ds. Round. Ship wt. 1/2 lb.

No. AC-45-S Set of 19 #AC-50 Collets, 1/16" to 5/8" by 32ds. Ship. wt. 8 lbs.

AUTOMATIC SAFETY GEAR

- Guards Gear Train Against Overload Shock
- Installed in Your Own Shop in 15 Minutes
- Fits Logan 9", 10", 11", 12" and 14" Quick Change Gear Lathes

In school shops or where operators are inexperienced, here is insurance against heavy repairs. When a sudden overload of the carriage feed using a half nut occurs the Automatic Safety Gear instantly throws out and a clicking noise warns of the overload. On correction of the overload condition, the Safety Gear automatically resumes engaged position. By its automatic throw-out action, the Automatic Safety Gear protects all lathe gears from spindle to gear box in case the carriage or the tool becomes jammed against movement. It also protects the gears within the gear box for all except 52 threads per inch and finer, or corresponding feeds, where there is tremendous torque build-up within the gear box.

No. LB-240 Fits Logan 9" Quick Change Gear Lathes. Shipping weight, 7 lbs.

No. LA-775-1 Fits Logan 10" and 11" Quick Change Gear Lathes with Serial Numbers 67839 and over. Shipping weight 7 lbs.

Now furnished as standard equipment on new 11" Q.C. Lathes and Models 1825, 1875 of the 10" Q.C. Lathes.

No. LA-774-1 Fits Logan 10" and 11" Quick Change Gear Lathes from Serial Number 46562 to 67838 and 2900 Series 12" Lathes. Shipping weight 9 lbs.

No. 2410 Fits Logan 12" 2500 Series Lathes and all 14" Lathes. Shipping weight 7 lbs. Now furnished as standard equipment on new 12" and 14" Lathes.

No. LB-240 or No. LA-775-1 will, on request, be factory-installed on a new lathe.

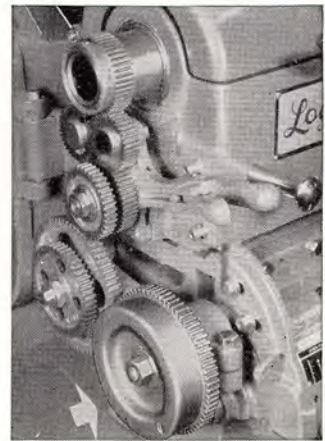

Logan ACCESSORIES

LEVER TAILSTOCKS

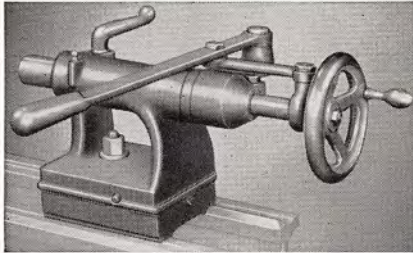

Provides lever operation to the tailstock in addition to the regular handwheel tailstock operation. Particularly valuable for repeat operations in production.

Cat. No.	For Lathe	Lever Stroke	Morse Taper	Ship. Wt.
AC-240	#1400	2 3/4"	No. 2	15 lbs.
LB-192	#9B	2 3/4"	No. 2	15 lbs.
AC-241	10"	2 3/4"	No. 2	30 lbs.
AC-375	11"	3 3/4"	No. 2	34 lbs.
AC-384	12"	4"	No. 2	45 lbs.

STANDARD TAILSTOCKS

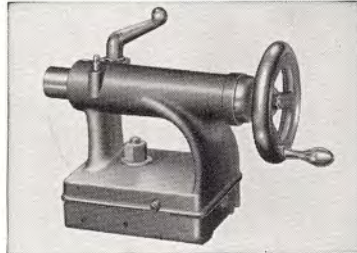

Tailstock assemblies if purchased for a turret lathe may be used to replace the turret for regular lathe operations. (Compound rest assemblies shown on the right may be ordered to replace the double tool post cross slide on a turret lathe.)

Cat. No.	For Lathe Size	Ship. Wt.
LA-3-1	10"	24 lbs.
LA-1065	11"	29 lbs.
2065	12"	32 lbs.

COMPOUND REST ASSEMBLIES

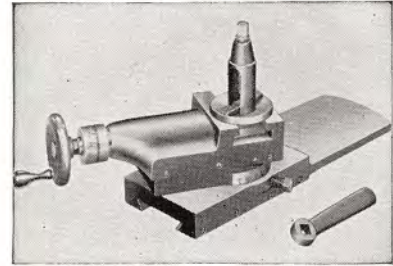

Compound rest assemblies may be ordered to replace the double tool post cross slide on turret lathes to convert for regular lathe operation. Also see tailstock assemblies on left. In ordering compound rest assemblies, give serial number of lathe on which it is to be used.

Cat. No.	For Lathe Size	Ship. Wt. Lbs.
LA-49-5	10" Lathes, serial #50843 and over. For all 11" lathes.	13
2085	12" Lathes, #2500 series.	25

QUICK CHANGE GEAR ATTACHMENT



Converts a Logan plain change gear lathe for quick change gear operation

Provides 48 threads and feeds in either direction. Screw threads from 8 to 224 per inch. Two lever adjustment. Changing 36-tooth stud gear for 72-tooth stud gear, provides additional threads of from 4 to 7 per inch. Complete with a replacement lead screw, parts and installation instructions. Attachments have longitudinal power feed and power cross feed from .0044" to .2500" per spindle revolution.

No. LA-1200-1—For 10" and 11" lathes, 24" centers. Ship. wt., 24 lbs.

No. LA-959-1—For 10" Lathes, 31" centers. Ship. wt., 24 lbs.

No. LA-958-1—For 11" Lathes, 36" centers. Ship. wt., 26 lbs.

LOGAN METRIC TRANSPOSING GEARS

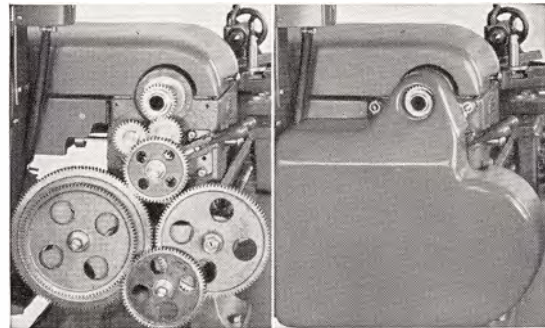

Without Gear Guard

With Gear Guard

Equip Logan 10" and 11" lathes to cut metric screw threads

Each of these complete sets includes bracket, gear guards and transposing gear chart. Each equips a standard Logan Lathe to cut right hand and left hand metric screw threads ranging from 6 mm. pitch to .020 mm. pitch. All gears semi-steel, 16 pitch, 7/16" wide and carefully machined.

No. AC-130 For 10" Plain Change Gear Lathes. Shipping weight, 29 lbs.

No. AC-143-1 For 10" Quick Change Gear Lathes with Serial No. 46561 and up. Shipping weight, 35 lbs.

No. AC-320-1 For 11" Quick Change Gear Lathes. Shipping weight, 35 lbs.

LATHES FACTORY EQUIPPED WITH TRANSPOSING GEARS . . .

May be specified by prefixing the letter "M" to the catalog number of the lathe ordered. In addition to metric transposing gears, gear guards, bracket and metric transposing chart, standard gears, gear bracket and chart necessary for cutting English screw threads are also shipped with these "M" lathes.

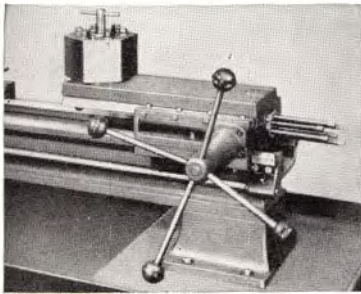

LA-70 Bed Turret

Fits bedways of Logan 10", 11" and 12" Screw Cutting Lathes. Interchangeable with the tailstock, and used with a Double Tool Post Cross Slide to replace the compound rest, it converts such a lathe into a turret lathe. Extra heavy construction assures maximum smoothness and accuracy. Turret lock furnished provides increased rigidity for heavy cuts. 5 1/4" across turret head flats—adjustable gibs on side—furnished unbored. Can be bored at factory at no extra charge if ordered with a lathe. Specify 5/8" or 3/4" turret holes.

No. LA-70 Pilot Wheel Turret. 7 3/4" max. stroke. Shipping Wt., 110 lbs.

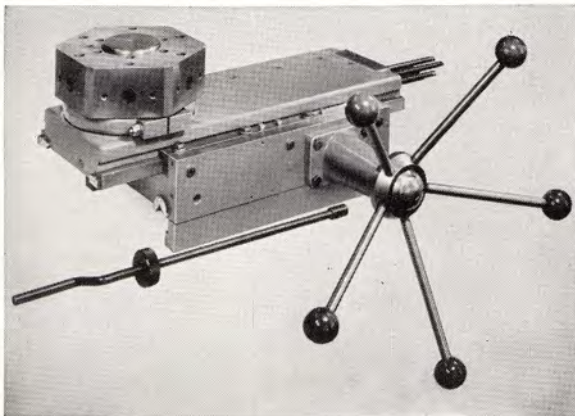

No. 6600 Bed Turret

Fits bedways of Logan 14" Screw Cutting Lathes. Clearance center of tool holes to top of turret cross slide, 2 9/16". Turret head indexes and locks automatically. Width of turret block across flats, 8 1/2". Bolt holes in face, 1/16"-14. Turret block locked by cam operated locking ring. Maximum travel at one setting, 9". Slide length, 21". Base length, 17". Furnished with 7/8" machined holes. Can be bored at factory up to 1 1/2" diameter holes when ordered with lathe. Specify hole size when ordering and see price list for factory boring, counterboring and facing charge.

No. 6600 Pilot Wheel Turret. Shipping Wt., 350 lbs.

No. 521 TAILSTOCK TURRET

Fits in No. 2 Morse Taper of Tailstock

Finger tip control rotates 6 tools in direct line with spindle. 2 1/2" diameter. 5/8" turret holes. Shipping wt., 4 lbs.



HEXAGON TURRETS

TURRET TOOL POSTS

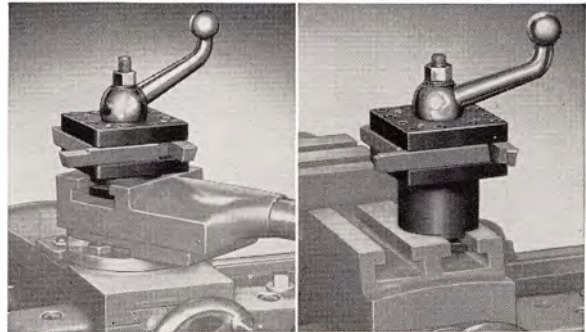

Quickly set up on the T-slot of a compound rest. Mount four tools up to 3/8". 12 stations available, with three working positions for each tool. On jobs requiring less than four tools, duplicate tools may be set up for uninterrupted production. Square tool block indexes at 30° intervals, providing a quick set-up for threading.

For Screw Cutting Lathes

No. 512 For 10" Screw Cutting Lathes, Serial Number 50843 and Over. For all 9", 11" and 12" Screw Cutting Lathes. Shipping wt., 4 lbs.

No. 513 For 10" Screw Cutting Lathes, Serial Number 50842 and Under. Shipping wt., 4 lbs.

No. 612 For 14" Screw Cutting Lathes. Ship. wt., 17 lbs.

For Turret Lathes

No. 514 For all 10", 11" and 2900 series 12" Turret Lathes. Shipping wt., 5 lbs.

No. 2094 For 2500 series 12" Turret Lathes. Shipping wt., 6 lbs.

No. 612/6423 For 6530 Turret Lathe

DOUBLE TOOL POST CROSS SLIDES

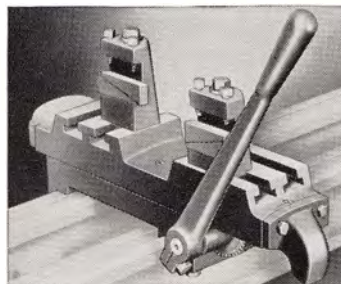

Lever Operated

Clamps directly to lathe bed. Lever operated. Has adjustable stops with maximum travel of 3". Adjustable wedges for tool holder slots included.

No. LA-25-1 For all Logan 10" Lathes. Ship. Wt., 38 lbs.

No. LA-1108 For all Logan 11" Lathes. Ship. Wt., 39 lbs.

No. LA-29-1-L Same as LA-29-1 but with added lever operation. Ship. Wt., 27 lbs.

No. 2095-L Same as 2095 but with added lever operation. Ship. Wt., 30 lbs.

No. 6410-L Same as 6410 but with added lever operation. Ship. Wt. 70 lbs.

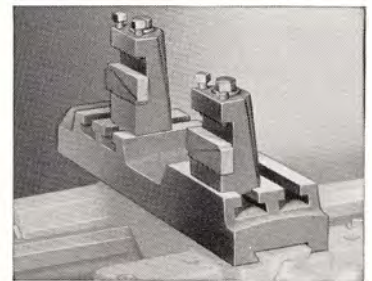

Manual Feed

Replaces compound rest for hand wheel or power cross feed operation. In ordering double tool post cross slides, give serial number of lathe on which it is to be used.

No. LA-29-1 For Logan 10" Lathes, serial #29568 and over. For all Logan 11" Lathes. Ship. Wt., 24 lbs.

No. 2095 For 12" Lathes, 2500 series. Ship. Wt., 27 lbs.

No. 6410 For 14" Lathes. Shipping Wt., 65 lbs.

Logan L A T H E



SOLID BORING BAR

Used with No. 556 Boring Tool Holder. Can be ground for internal thread cutting as well as for boring.

Catalog No.	Size	Ship. Wt.
570-A	1/8" x 4"	1/4 lb.
570-B	3/16" x 4 1/2"	1/4 lb.
570-C	1/4" x 5"	1/4 lb.
570-D	5/16" x 6"	1/4 lb.
570-E	3/8" x 7"	1/2 lb.
570-F	7/16" x 8"	1/2 lb.

HEAVY DUTY BORING TOOL SETS

Mounts on compound and is held in place by regular tool post.

No. AC-120 Heavy Duty Boring Bar Tool Set for Logan 9", 10", 11" and 12" lathes. Includes 3/8", 1/2", 5/8" and 3/4" bars. Each bar holds a tool bit at each end, one mounted at 45°, the other at 90°. Tool bits and wrenches included. Also holds all sizes of No. 570 bars. Shipping weight, 8 lbs.

No. 6375 Heavy Duty Boring Bar Tool Set for Logan 14" lathe. Includes 3/8", 1/2", 5/8", 3/4", 1" and 1 1/4" bars with two bits on each bar. Complete set packed in wood box, 1 holder, 6 boring bars, tool bits and wrenches. Shipping weight, 23 lbs.

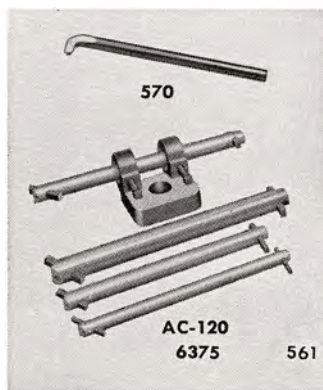

CUTTER BITS

No. 560 HSS Blank Cutter Bits, size 1/4" x 1/4"—packaged set of 6, ship. wt. 1 lb.

No. 561 HSS Formed Cutter Bits, size 1/4" x 1/4"—packaged set of 6, ship. wt. 1 lb.

No. 558 Discontinued

No. 660 HSS Blank Cutter Bits, size 3/16" x 3/16". Packaged set of 6. Ship. wt. 1 lb.

TOOL HOLDERS

For 9", 10", 11" and 12" Logan Lathes, 3/8" x 3/4" Shanks

Drop forged steel heat treated tool holders individually boxed and including wrench and tool bit.

Cat. No.	Description	Cutter Size	Ship. Wt.
550	L. H. Turning Tool Holder	1/4" sq.	1 lb.
551	R. H. Turning Tool Holder	1/4" sq.	1 lb.
552	Straight Turning Tool Holder	1/4" sq.	1 lb.
553	Threading Tool Holder	60° thread	1 lb.
554	R. H. Cut-off Tool Holder	3/2 x 3/8"	1 lb.
557	Straight Cut-off Tool Holder	3/2 x 3/8"	1 lb.
555	Knurling Tool Holder	Med. Dia. Knurls	1 lb.
556	Boring Tool Holder	1/4" bar	1 lb.
549	Tool Holder Set. One each of above. Eight tool holders in a steel box.		7 lbs.
563	Extra Threading Cutter, 60°, for 553 Tool Holder		1/2 lb.
564	Extra Cut-off Blade for 554 or 557 Tool Holder		1/4 lb.
565	Extra Diamond Knurls for 555 Tool Holder. Specify fine, medium, or coarse.		1/4 lb.

For 14" Logan Lathes, 1/2" x 1 1/8" Shanks

650	L. H. Turning Tool Holder	3/16" sq.	1 1/2 lbs.
651	R. H. Turning Tool Holder	3/16" sq.	1 1/2 lbs.
652	Straight Turning Tool Holder	3/16" sq.	1 1/2 lbs.
653	Threading Tool Holder	60° Thread	1 1/2 lbs.
654	R. H. Cut-off Tool Holder	1/6 x 3/4"	1 1/2 lbs.
657	Straight Cut-off Tool Holder	1/6 x 3/4"	1 1/2 lbs.
655	Knurling Tool Holder	Med. Dia. Knurls	1 1/2 lbs.
663	Extra Threading Cutter, 60°, for 653 Tool Holder		1/2 lb.
664	Extra Cut-off Blade for 654 or 657 Tool Holder		1/4 lb.
665	Extra Diamond Knurls for 655 Tool Holder. Specify fine, medium, or coarse.		1/4 lb.

CENTER COUNTERSINK DRILLS

Drill and countersink bearings for Lathe Center. Three sizes.

No.	Size	Ship. wt.
575-A	1/16"	1/4 lb.
575-B	3/32"	1/4 lb.
575-C	1/8"	1/4 lb.

60° MALE CENTER

No. LA-187 Hardened, ground. No. 2 M. T. shank. Ship. wt. 1/2 lb.

No. 6113 Hardened, ground. No. 3 M. T. Shank. Ship. wt. 1 lb.

LATHE DOGS

Bent Tail Type with Square Head Set Screw (Standard Lathe Dog) and Hollow Headless Set Screw (Safety Lathe Dog)

Standard No.	Safety No.	Cap.	Ship. Wt.	Safety Dog Wrench No.
580A	581A	3/8"	1/4 lb.	0880
580B	581B	1/2"	1/4 lb.	0880
580C	581C	3/4"	1/4 lb.	0886
580D	581D	1"	1/2 lb.	0887
580E	581E	1 1/4"	1/2 lb.	0893
580F	581F	1 1/2"	1/2 lb.	0893

Clamp Type

No.	Cap.	Ship. wt.
585	1 3/4"	1/2 lb.
586	2 1/4"	3/4 lb.

DRIVE AND FACE PLATES

Cat. No.	Description	Diam.	Spindle Size	Ship. Wt. Lbs.
LA-170	Drive Plate	6"	1 1/2"-8 thd.	4
LA-1009	Drive Plate	6"	2 1/4"-8 thd.	4
6005	Drive Plate	7 1/2"	2 1/4"-8 thd.	6
2307	Drive Plate	7"	L-00	10
LA-344*	Face Plate	8"	1 1/2"-8 thd.	6
LA-1008	Face Plate	8"	2 1/4"-8 thd.	6
2010†	Face Plate	10"	2 1/4"-8 thd.	16
2310	Face Plate	10"	L-00	16
6383*	Face Plate	12"	2 1/4"-8 thd.	21
6806	Face Plate	12"	L-0	26
6807	Drive Plate	7 1/2"	L-0	13

*Fits 14" lathes only.

†Fits 12" and 14" lathes only

*Fits 10" lathes only.

ADJUSTABLE MACHINE LIGHT

Bolts directly on machine, or slips into bracket mount. Double arm has three flexible joints. Takes 100-watt, A-21 lamp. Overall length, 37 1/2". 8' heavy duty cord and plug.

No. 500 Shipping weight, 4 lbs

No. 501 Koolshield for Above. Ship. Wt. 1 lb.

ANTI-FRICTION CENTER

Superior quality. Live center. Grease-sealed precision bearings. Centerpiece angle 60°.

No. 595 No. 2 Morse Taper Shank. Ship. Wt., 3 lbs.

No. 596 No. 3 Morse Taper Shank. Ship. Wt., 4 lbs.

DRILL PAD

No. A C-300 No. 2 Morse Taper. 2" Diameter. Ship. Wt., 1 lb.

LACQUER ENAMEL

No. 498 1 pt.—Matches Standard Logan Light Gray. Brush or Spray. Shipping wt., 2 lbs.

No. 499 1 pt.—Matches Standard Logan Dark Gray. Brush or Spray. Shipping wt., 2 lbs.



ACCESSORIES

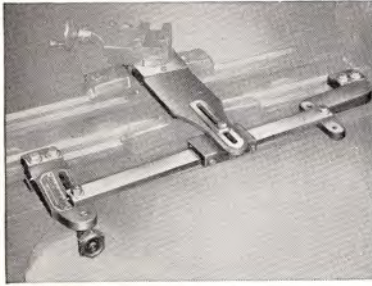

TAPER ATTACHMENTS

Exclusive "Micro-Screw" feature gives quick, positive adjustments of slide bar to desired taper. Easily installed, with taper attachment cross slide becoming a permanent part of the lathe.

Cat. No.	Lathes	Maximum Taper Length At One Setting	Per Ft.	Angle 0°	Ship. Wt. lbs.
AC-270	400-1400	7"	4"	19°	15
AC-275	9B series	7"	4"	19°	15
AC-298	10"	12½"	4"	19°	18
AC-295	11"	12½"	4"	19°	20
AC-2296†	12"	12½"	4"	19°	22
2350*†	12"	10"	4½"	20°	48
6329*★	14"	10"	4½"	20°	60

*TELESCOPIC TAPER ATTACHMENT—Telescopic cross feed screw eliminates disengaging cross feed screw nut as is necessary with plain Taper Attachments.

†For "2500" series 12" Lathes only.

*★For all 14"x28" Lathes and for 14"x40" Lathes from serial #78562.

DIRECT READING CROSS FEED DIAL—

CANNOT BE USED WITH TELESCOPIC TAPER ATTACHMENT

*No. 2470 Direct Reading Cross Feed Dial Assembly for 12" 2500 series lathes. To be installed by customer.

No. 2471 Same as 2470 but factory installed on new 12" lathe in place of standard cross feed dial assembly.

*No. 6151 Direct Reading Cross Feed Dial Assembly for 14" engine lathes. To be installed by customer.

No. 6152 Same as 6151 but factory installed on new 14" engine lathe in place of standard cross feed dial assembly.

No. 12630 Direct Reading Cross Feed Dial Assembly for 10" and 11" lathes from Serial No. 71060. To be installed by customer.

No. 12631 Same as 12630 but factory installed on new 10" or 11" lathe in place of standard cross feed dial assembly.

*Includes cross feed screw and nut.

MICA UNDERCUTTER

No. 490 For Logan 9", 10", 11" and 12" Lathes. Shipping weight, 8 lbs.

No. 488 Mica Undercutter Saws. Packet of 6 blades .015". Ship. wt. ¼ lb.

No. 489 Mica Undercutter Saws. Packet of 6 blades .020". Ship. wt. ¼ lb.

AUXILIARY HEAD

Adapts Logan 11" Lathes for Oversize Work

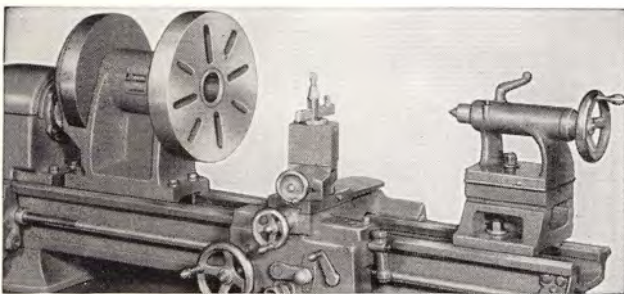

Mounted on Logan 11" Lathe. Note raising blocks in position under the tool post and tailstock

Gives Logan 11" Lathes 16" Swing over bed and 14½" Swing over saddle wings . . . Ball Bearing Mounted Spindle . . . 2¼", 8-Thread Spindle Nose . . . Attached in 10 minutes, easy to detach . . . 12" Face Plate.

Gear reduction feature permits cutting threads four times as coarse as in regular operation. Spindle center is set back as well as elevated. As a result, in turning large work, the pressure from the cut is over the lathe way, not overhanging. Provides the smooth operation on heavy cuts essential to accuracy. Raising blocks for the tool post and tailstock assembly furnished.

No. AC-400 Shipping weight, complete, 140 lbs.

CARRIAGE STOPS

No. AC-234 Micrometer Carriage Stop. Collar graduated in .001". Setting may be locked for duplicate work. For 9", 10", 11" and 12" Logan Lathes. Ship. wt., 3 lbs.

No. 6365 Micrometer Carriage Stop. Graduated in .001" with collar lock. For Logan 14" Lathes. Ship. wt., 5 lbs.

No. AC-226 Double Carriage Stop. Adjustable screws set carriage for two desired positions. Used either side of carriage. For 9", 10", 11" and 12" Logan Lathes. Ship. wt., 3 lbs.

No. AC-225 Carriage Stop. Used either side of carriage. Screw with lock-nut gives accurate adjustment. For 9", 10", 11" and 12" Logan Lathes. Ship. wt., 2 lbs.

MULTIPLE CARRIAGE STOP

Six positions. Mounts on lathe bed.

No. AC-435 For all 12" Lathes. Ship. wt., 5 lbs.

No. AC-437 For all Quick Change 11" Lathes. Ship. wt., 5 lbs.

6425 For 14" Lathes. Ship. wt. 12 lbs.

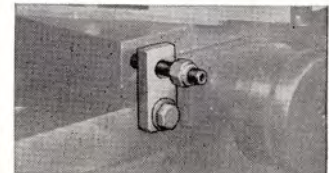
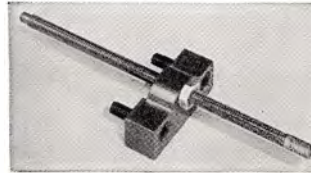

THREADING STOPS

No. AC-352 6" adjustable range. Mounts on rear of saddle on 9", 10" and 11" Logan Lathes. Adjustable screw for positive stop against cross feed nut. Template furnished. Shipping weight, 3 lbs.

No. 6380 For 12" and 14" Logan Lathes. Mounts on saddle with adjustable screw in compound base. Template furnished. Shipping weight, 3 lbs.

CENTER RESTS

The center rest (or steady rest) mounts on the lathe bed to support long thin work and prevent distortion. Three adjustable machined jaws.

Cat. No.	Capacity	Lathe Size	Ship. Wt.
AC-280	3"	400-1400	9 lbs.
AC-282	3"	9B series	9 lbs.
AC-189	3"	10"	10 lbs.
AC-290	3"	11"	10 lbs.
AC-2189	3"	12"	11 lbs.
6315	4¼"	14"	23 lbs.



FOLLOWER RESTS

The follower rest mounted on the lathe carriage and travels with the carriage to support long thin work. Two adjustable machined jaws.

Cat. No.	Capacity	Lathe Size	Ship. Wt.
AC-285	3"	9"	4 lbs.
AC-196	3"	10", 11"	5 lbs.
AC-2196	3"	12"	6 lbs.
6320	4¼"	14"	9 lbs.

BAR FEED

For use on No. 1830-2 Hand Screw Machines only. Maximum capacity ⅝" round stock. Maximum feed per stroke is 2". No. AC-50 Push Type Collets are used in sizes from ⅛" to ⅝". A patented cam action prevents feeding while bar is being locked in collet and eliminates locking while bar is being fed.

No. IA-32-34 Ship. wt. 45 lbs.

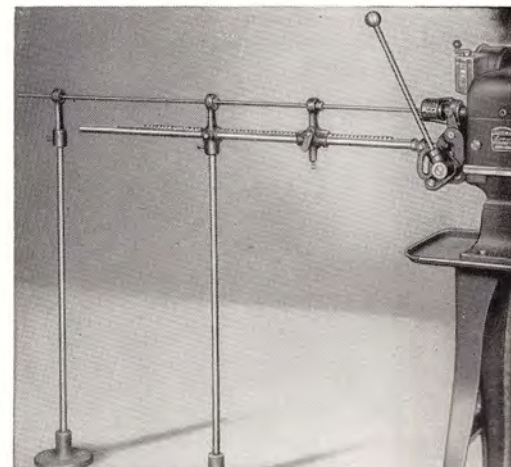

ELECTRIC MOTORS

Stock motors listed below are manufactured by dependable sources and have drip proof open type frames. Single phase motors are capacitor type start-stop-reverse, and three phase motors are quick reversing. We definitely recommend three phase motors on motor

sizes of 1 H.P. or larger and wherever possible on the smaller sizes. There will be a charge on a cost basis for mounting customers' motors on Logan machines. In addition to the stock motors listed, we can supply motors for special requirements on request.

Cat. No.	H.P.	R.P.M.	Phase	Voltage	Cycle	Bear-ings	Lathe Size or Model	Ship. Wt.
1101	1/8	1725	1	110/220	60	Ball	9"	33 Lbs.
1105	1/2	1725	1	110/220	60	Ball	9" or 10"	50 Lbs.
1106	1/2	1725	1	110/220	50	Ball	9" or 10"	50 Lbs.
1110	1/2	1725	3	220/440	60	Ball	9" or 10"	50 Lbs.
1111	1/2	1725	3	220/380	50	Ball	9" or 10"	50 Lbs.
1114	1 1/2	1800/900	3	220	60	Ball	12"	40 Lbs.
1116	1 3/4	1725	1	110/220	60	Ball	11"	65 Lbs.
1118	3/4	1725	3	220/440	60	Ball	11"	60 Lbs.
1120	1	1725	3	220/440	60	Ball	12"	60 Lbs.
1122	2	1725	3	220/440	60	Ball	14" (6510 & 6560)	70 Lbs.
1122DB	2	1725	3	220/440	60	Ball	14" (6565 & 6530)	70 Lbs.
1123	3	1725	3	220/440	60	Ball	14" (6565 & 6530)	85 Lbs.
1123DB	3	1725	3	220/440	60	Ball	14" (6565 & 6530)	85 Lbs.
1124	2/1	1800/900	3	220	60	Ball	14" (6565 & 6530)	85 Lbs.
1124DB	2/1	1800/900	3	220	60	Ball	14" (6565 & 6530)	85 Lbs.
1125	3 1/2	1800/900	3	220	60	Ball	14" (6565 & 6530)	110 Lbs.
1125DB	3 1/2	1800/900	3	220	60	Ball	14" (6565 & 6530)	110 Lbs.

NOTE: Two speed motors are single voltage. 220V motors are stocked. 440V motors must be ordered. Motors having "DB" suffix are dynamic-braking motors.

MOTOR SWITCHES AND MOTOR CONTROLS SAFETY BRAKES AND POWER CONTROLS

Optional electrical equipment for all Logan Cabinet Model Lathes and Shaper. Price includes complete installation and wiring when ordered with Lathe or Shaper.

- No. 0388** High-Low Switch for 2-speed motor. Used in addition to regular drum reversing switch or reversing magnetic starter furnished or ordered with lathe.
- No. 0391** Drum Switch for 2 or 3 H.P. single speed regular motor.
- No. 0408** Drum Switch for 2 or 3 H.P. single speed dynamic-braking motor.
- No. 2325** Thermal Overload Switch. Separate unit used between regular drum switch and motor. Automatically cuts out to prevent damage to motor from overheating due to overload.
- No. 2330** Magnetic Overload and Undervoltage Switch. Magnetic relay unit used in conjunction with regular drum switch, providing complete motor protection plus safety protection to machine and operator. Stops motor when voltage drops below safe level or power is interrupted.
- No. 6350** Reversing Magnetic Starter (3 Phase). Complete motor protection as well as safety protection to machine and operator. Full motor load carried through starter only—control circuit carries only enough current to operate the magnets which open and close the contacts. Push button station has FORWARD-REVERSE-STOP. Large mushroom head stop button is extra sensitive and easily operated from a wide angle for quick stops. For 10", 11" and 12" cabinet model lathes and 6510 and 6560 series 14" lathes. NOTE: Can also be ordered for bench and floor model 10" and 11" lathes for customer installation.
- No. 6350DB** Reversing Magnetic Starter. Same as 6350 but for dynamic-braking motor.
- No. 6350T** Reversing Magnetic Starter with Control Transformer. Same as 6350 but with transformer reducing voltage to push buttons. Recommended for 440V installation.
- No. 6350DB-T** Reversing Magnetic Starter with Control Transformer. Same as 6350-T but for dynamic-braking motor.
- No. 6355** Reversing Magnetic Starter (3 Phase). Same as 6350 Reversing Magnetic Starter but for use on the 6565 Lathe and 6530 Turret Lathe.
- No. 6355DB** Reversing Magnetic Starter. Same as 6355 but for dynamic-braking motor.
- No. 6355T** Reversing Magnetic Starter with Control Transformer. Same as 6355 but with transformer reducing voltage to push buttons. Recommended for 440V installation.
- No. 6355DB-T** Reversing Magnetic Starter with Control Transformer. Same as 6355-T but for dynamic-braking motor.
- No. AC-115** Drum Reversing Switch, Switch Box and 30" Rubber Covered Cable. For 9" Lathes.
- J.I.C. CONTROLS.** Magnetic Starter (fused or non-fused), oiltight push button controls, and totally enclosed motors to J.I.C. specifications. For these and any other unlisted controls, contact factory.

(FACTORY INSTALLED)

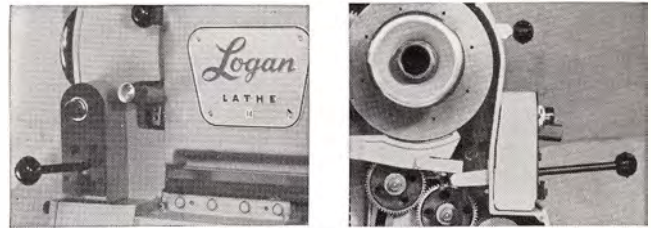

Downward movement of the brake lever stops lathe immediately. Push-button above brake lever re-starts lathe in same direction.

		Lathe Size or Model
No. J-139	Safety Brake and Power Control without Overload and Undervoltage Protection, 208-220V.....	12"
No. J-140	Safety Brake and Power Control with Overload and Undervoltage Protection, 208-220V.....	12"
No. J-141	Same as J-140—with Transformer. For 440V installation.....	12"
No. J-101	Safety Brake and Power Control with Overload and Undervoltage Protection, 208-220V.....	6510, 6560
No. J-102	Same as J-101—with Transformer. For 440V installation.....	6510, 6560
No. J-103	Safety Brake and Power Control without Overload and Undervoltage Protection, 208-220V.....	6510, 6560
No. J-104	Combination Safety Brake and Magnetic Reversing Starter, with Push Buttons in Brake Well, 208-220V.....	6510, 6560
No. J-110	Same as J-104—with Transformer. For 440V installation.....	6510, 6560
No. J-105	Safety Brake and Power Control without Overload and Undervoltage Protection, 208-220V.....	6565, 6530
No. J-106	Safety Brake and Power Control with Overload and Undervoltage Protection, 208-220V.....	6565, 6530
No. J-107	Same as J-106—with Transformer. For 440V installation.....	6565, 6530
No. J-108	Combination Safety Brake and Magnetic Reversing Starter, with Push Buttons in Brake Well, 208-220V.....	6565, 6530
No. J-111	Same as J-108—with Transformer. For 440V installation.....	6565, 6530

NOTE: All of the above are used with a drum switch except No. J-104, J-110, J-108, and J-111. On brakes for 14" lathes below Serial No. 79750 consult factory.

Logan

8" SHAPER

SPECIFICATIONS

Length of ram, 19" . . . width of ram, $5\frac{3}{16}$ " . . . width of ram ways, $5\frac{3}{16}$ " . . . cross-rail ways, $\frac{5}{8}$ " x $\frac{3}{4}$ " x $5\frac{1}{4}$ " . . . length of stroke, $8\frac{1}{2}$ " . . . length of ram bearings, 19" . . . bearing surface of ram, 51 sq. in. . . vertical travel of tool head, $2\frac{3}{8}$ " . . . size of tool holder, $\frac{7}{16}$ " x $\frac{7}{8}$ " . . . tool head swivel, 360° . . . tool head diameter, 4" . . . length of cross rail, $13\frac{7}{8}$ " . . . horizontal travel of table, $10\frac{1}{2}$ " . . . vertical travel of table, $5\frac{1}{2}$ " . . . distance, top of table to ram (maximum), 6" . . . working surface of table, 8" x 8" . . . the adjustable table support mounted on the base of the machine provides solid reinforcement . . . slots in table (3 on top and 3 on side), $\frac{7}{16}$ " . . . table depth, $7\frac{1}{2}$ " . . . saddle bearing, $5\frac{1}{4}$ " . . . feeds, .002, .004, .006, .008, .010 and .012" . . . a half turn of the feed handle in either direction reverses the feed . . . speeds, "Anyspeed," 35 to 180 strokes per minute . . . speed changes are effected instantly by simply turning the hand wheel control—no need to stop motor or shift belt . . . size of motor, $\frac{1}{2}$ H.P. or $\frac{3}{4}$ H.P. . . . cutting speeds, up to 120 feet per minute . . . vise, swivel 300°, $5\frac{1}{4}$ " opening, 5" width . . . weight with motor, 700 Lbs. . . overall dimensions, 15" wide, 35" deep, 51" high.

LOGAN 8-INCH SHAPERS

- No. ES8-S $\frac{1}{2}$ With $\frac{1}{2}$ H.P., 1 Phase, 110/220V, 60-Cycle Motor. Ship. Wt. 690 Lbs.
- No. ES8-T $\frac{1}{2}$ With $\frac{1}{2}$ H.P., 3 Phase, 220/440V, 60-Cycle Motor. Ship. Wt. 690 Lbs.
- No. ES8-S $\frac{3}{4}$ With $\frac{3}{4}$ H.P., 1 Phase, 110/220V, 60-Cycle Motor. Ship. Wt. 700 Lbs.
- No. ES8-T $\frac{3}{4}$ With $\frac{3}{4}$ H.P., 3 Phase, 220/440V, 60-Cycle Motor. Ship. Wt. 700 Lbs.

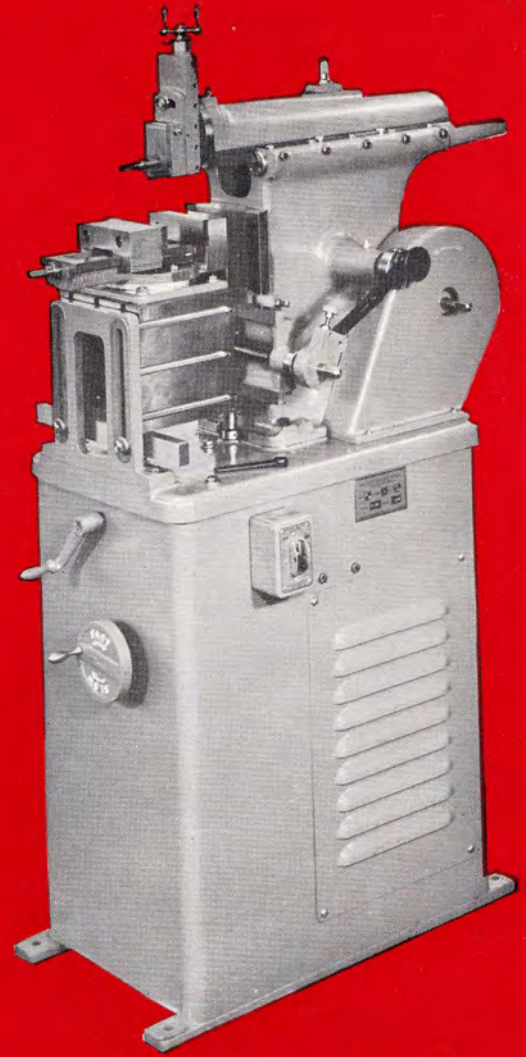

SHAPER ACCESSORIES



INDEX CENTERS

No. 80199 5 inches between centers. 3-inch swing. Index plate with divisions between 22-30. Shipping wt., 16 lbs.

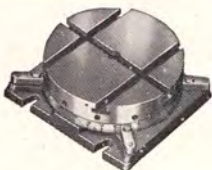

ROTARY TABLE

No. 80249 7" diameter work surface with 3 "T" slots. Shipping wt., 23 lbs.



ANGLE PLATE

No. 80275 For clamping irregular work to table. Size, 3" x 3" x 5". Ship. wt., 7 lbs.



SHAPER TOOL HOLDER

No. 540 Standard Tool Holder. Ship. wt., 1 lb.

SHAPER EXTENSION TOOL HOLDER

No. 541 For Inside Work. Ship. wt., 1½ lbs.

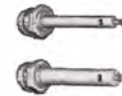
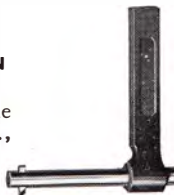

KEYWAY TOOL HOLDERS

No. 80280 $\frac{1}{16}$ " for Cutting Keyways and Slotting on Inside Work. Ship. wt. 1 lb.

No. 80281 $\frac{5}{8}$ " for Cutting Keyways and Slotting on Inside Work. Ship. wt., 1 lb.

BLANK CUTTER BITS

No. 560 Set of 6. Unground, measure $\frac{1}{4}$ x $\frac{1}{4}$ x 2". Heat treated high speed steel. Shipping wt., 1 lb.

"T" HEAD BOLTS

No.	Size	Ship. wt.
80355	$1\frac{1}{16}$ "	$\frac{1}{2}$ lb.
80260	$2\frac{1}{4}$ "	$\frac{3}{4}$ lb.
80261	$3\frac{1}{4}$ "	1 lb.

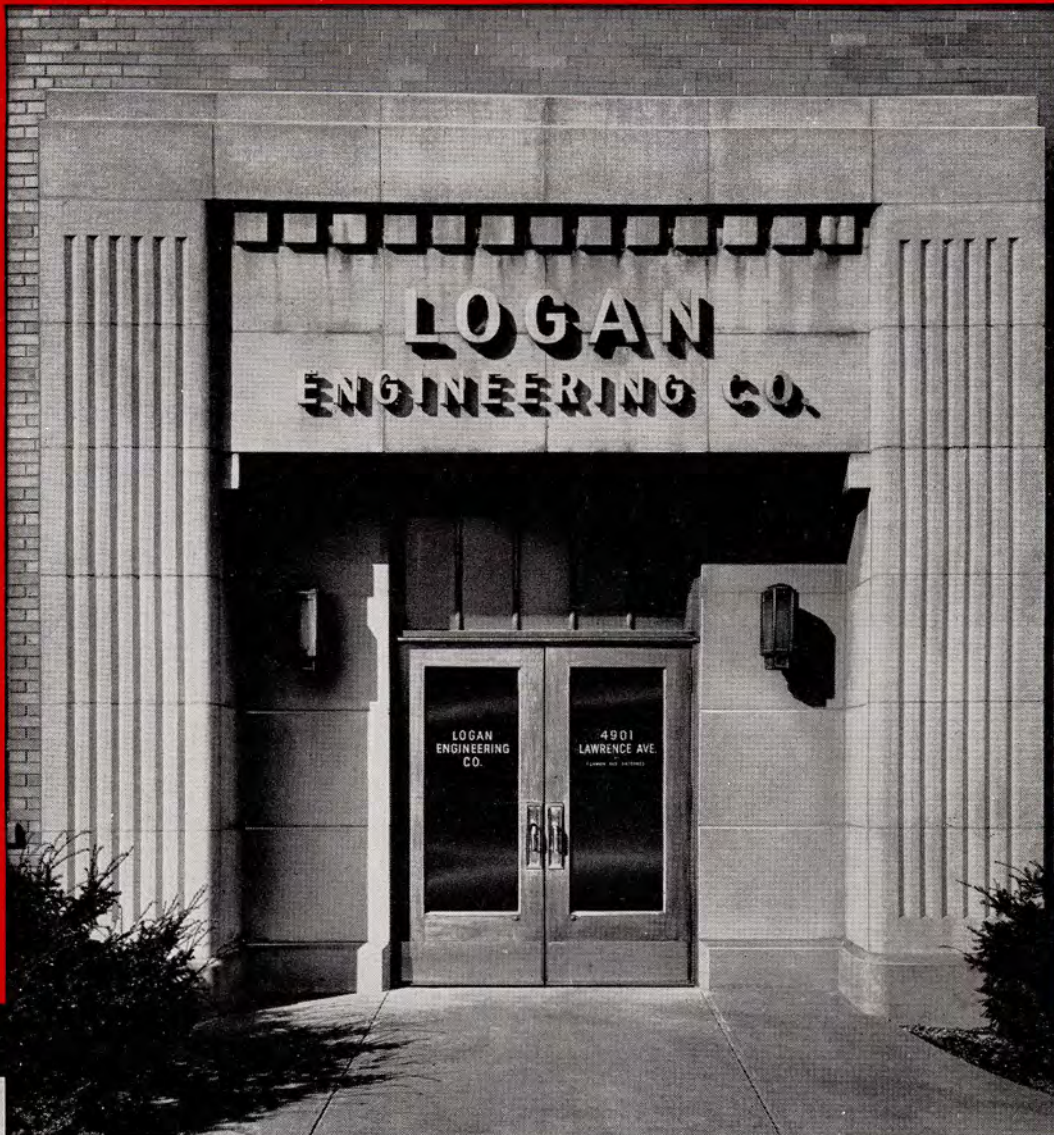

The proving ground for Logan Lathes has been in the factories and shops of American industry. Over a period of years the record made by Logan Lathes on the job has earned widespread acceptance and high regard for Logan products. Pride in these results, made possible by the coordinated effort of the entire Logan organization, is only natural. A continuing program of improvement in equipment, methods and design is under way to maintain the leading position of Logan products in their respective fields.

LOGAN ENGINEERING CO. CHICAGO 30, ILLINOIS

LOOK TO

Logan

FOR *BETTER* LATHES AND SHAPERS

Catalog LS 566 5M MP

Printed in U.S.A.

CARPENTERS Machinery co.

DISTRIBUTORS FOR WOOD
and METAL WORKING MACHINERY
PORTABLE ELECTRIC TOOLS

212 N. ELEVENTH STREET
Philadelphia 7, Penna.
WAlnut 2-7034 - 7035

November 3, 1966

Mr. Gary P. Bell, Metals Instructor
Manheim Central School District
Manheim, Pennsylvania

Dear Mr Bell,

We have been advised by Logan Engineering Company of Chicago, Illinois that you are interested in their line of equipment.

As their Philadelphia distributor, we will be more than happy to assist you in any way possible.

Please do not hesitate to call upon us.

Very truly yours,

CARPENTERS MACHINERY CO., INC.

R. Liebgott
R. Liebgott

RL/mr

LOGAN ENGINEERING CO.

Back-Geared Screw-Cutting and Turret Lathes

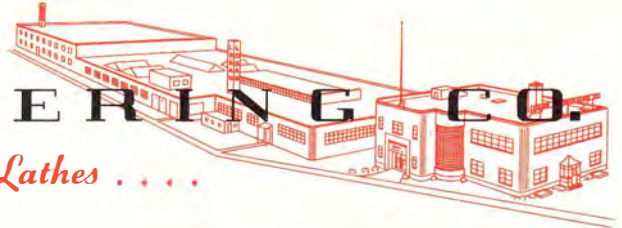

THE Logan LINE • LATHES, SHAPERS, ARIDIFIERS, MINE HOIST CONTROLLERS AND RECORDERS, HYDRAULIC PRESSES AND PREFORMERS

4901 WEST LAWRENCE AVENUE
CHICAGO, ILLINOIS 60630
PHONE: AREA CODE 312 • 736-7500
CABLE ADDRESS: "LOGANENG"

NOTICE

Manufacturing has been suspended until further notice on the following models of lathes and shapers:

9B17-1
9B17-21
9B17-41
9B17-61
9B28-1
9B28-21
9B28-41
9B28-61
1815
1820
1830-2
1840-2
1825 **
1875 **
1835-2 **
1845-2 **
1915
1917
1920
1922
1940-2
1942-2
ES8-S 1/2
ES8-T 1/2
ES8-S 3/4
ES8-T 3/4

** Except for schools

Logan

**LATHES
SHAPERS
ACCESSORIES**

14'' SWING LATHES

ITEM No.	*LIST PRICE	ITEM No.	*LIST PRICE
Screw Cutting Lathes			
6510	\$1865.00	6560-H	\$2125.00
6510-H	1930.00	6561	2075.00
6520	1885.00	6561-H	2145.00
6520-H	1950.00	6565	2595.00
6560	2025.00		

Turret Lathes

6530	3199.00
------	---------

12'' SWING LATHES

Screw Cutting Lathes			
2525-V	1557.00	2555-V	1501.50
2527-V	1627.50	2557-V	1572.50

Turret Lathes

2535-2-V	1759.00	2545-2-V	1814.00
2537-2-V	1830.00	2547-2-V	1885.00

OPTIONAL EXTRA FEATURES

	ADDED *LIST PRICE
Flame Hardened Bed - 43''	\$45.00
Flame Hardened Bed - 55''	55.00
L-00 Spindle	17.50

11'' SWING LATHES

Screw Cutting Lathes			
■ 1915	872.50	1955	1142.50
■ 1917	925.00	1957	1205.00
■ 1920	945.00	1975	1235.00
■ 1922	995.00	1977	1297.50
1925	1200.00	1985	1292.50
1927	1265.00	1987	1355.00

Turret Lathes

1935-2	1447.50	■ 1942-2	1302.50
1937-2	1510.00	1945-2	1505.00
■ 1940-2	1250.00	1947-2	1570.00

OPTIONAL EXTRA FEATURES

	ADDED *LIST PRICE
Flame Hardened Bed - 43''	\$45.00
Flame Hardened Bed - 55''	55.00

SUGGESTED PRICE LIST

MAY 10, 1966

10'' SWING LATHES Screw Cutting Lathes

ITEM No.	*LIST PRICE	ITEM No.	*LIST PRICE
■ 1815	\$705.00	1825	\$955.00
■ 1820	772.50	1875	897.50

Turret Lathes

■ 1830-2	852.50	■ 1840-2	1080.00
1835-2	1192.50	1845-2	1245.00

OPTIONAL EXTRA FEATURES

Flame Hardened Bed - 43''

ADDED
*LIST PRICE
\$45.00

9'' SWING LATHES

■ 9B17-1	488.50	■ 9B28-1	535.00
■ 9B17-21	399.00	■ 9B28-21	446.50
■ 9B17-41	392.00	■ 9B28-41	440.00
■ 9B17-61	303.50	■ 9B28-61	351.00

LATHE ACCESSORIES

ITEM No.	*LIST PRICE	ITEM No.	*LIST PRICE	ITEM No.	*LIST PRICE
0880	\$.08	490	\$ 39.00	570A	\$.88
0886	.10	498	1.50	570B	1.16
0887	.12	499	1.50	570C	1.48
0893	.14	500	9.95	570D	1.70
100	222.00	501	1.35	570E	2.32
110	10.50	512	39.00	570F	3.21
150	279.00	513	39.00	575A	1.25
150-L	333.00	514	39.00	575B	1.25
150-LO	366.00	521	38.00	575C	1.25
160	13.50	525-2	89.50	580A	1.26
250	49.95	531	71.00	580B	1.26
444	42.00	536	58.00	580C	1.50
445	2.50	549	38.84	580D	1.86
446	2.50	550	3.21	580E	2.07
447	2.30	551	3.21	580F	2.07
448	1.60	552	3.21	581A	1.26
451	12.20	553	6.41	581B	1.26
452	18.30	554	3.79	581C	1.50
453	24.50	555	7.61	581D	1.86
454	29.00	556	7.61	581E	2.07
455	17.50	557	3.79	581F	2.07
459	34.50	558	DISC.	585	5.12
**475	6.60	560	2.25	586	6.84
476-S	108.60	561	2.30	595	35.45
477-S	205.85	563	4.17	596	35.45
488	.75	564	2.12	612	102.00
489	.75	565	2.99	612/6423	142.00

ALL PRICES F.O.B. FACTORY

** For 1/8'' and larger. Consult factory for prices on sizes below 1/8''.

*SUGGESTED LIST PRICE
■ TEMPORARILY SUSPENDED

SUGGESTED PRICE LIST

MAY 10, 1966

LATHE ACCESSORIES (Continued)

ITEM No.	*LIST PRICE	ITEM No.	*LIST PRICE	ITEM No.	*LIST PRICE
650	\$ 8.42	2743	\$ 140.00	8004	\$ 165.00
651	8.42	2744	140.00	8005	165.00
652	8.42	6005	11.50	8006	68.25
653	12.97	6113	4.10	8007	75.50
654	9.26	6151	37.50	8081	25.00
655	17.45	6152	28.00	8152	195.00
657	9.26	6300	68.25	1063/AC-105	112.00
660	3.45	6311	24.00	1063/AC-108	112.00
663	8.12	6313	15.00	1063/2300	130.00
664	2.53	6315	23.00	1064/AC-117	76.50
665	3.48	6320	12.95	1064/AC-126	76.50
2010	16.00	6325	22.75	1064/2303	89.00
2065	70.00	6329	242.50	1284/AC-117	97.50
2085	117.50	6340	75.50	1284/2303	110.00
2094	50.00	6365	20.25	1308-LO	149.00
2095	86.75	6375	36.75	1310/2306	187.00
2095-L	97.25	6380	6.00	1310/6313	165.00
2300	27.00	6383	20.00	1310/6836	194.00
2301	28.00	6385	19.00	3634/AC-113	156.50
2302	28.00	6410	125.00	3634/AC-114	156.50
2303	25.00	6410-L	145.00	3634/2305	175.00
2305	28.00	6425	30.00	3662/AC-113	198.50
2306	37.00	†6600	695.00	3662/AC-114	198.50
2307	24.00	6806	45.00	3662/2305	217.00
2310	25.00	6807	35.00	4733/2301	225.00
2350	220.00	6833	28.00	4733/6385	216.00
2380	60.00	6834	34.00	4733/6833	225.00
2390	63.00	6836	44.00	6309/2302	277.00
2410	15.75	7025	1775.00	6309/6311	273.00
2470	29.50	8000	165.00	6309/6834	283.00
2471	20.00	8001	165.00	12630	24.50
				12631	20.00

AC Series

**AC-30	6.25	AC-166	82.75	AC-300	5.25
AC-35-S	97.50	AC-189	13.75	AC-320-1	63.50
AC-45-S	188.00	AC-196	10.00	AC-325	11.75
**AC-50	9.75	AC-225	6.50	AC-340	19.50
AC-101	7.50	AC-226	11.50	AC-345	22.50
AC-104	9.00	AC-234	15.25	AC-350	20.50
AC-105	12.50	AC-240	71.50	AC-352	5.50
AC-107	9.00	AC-241	76.25	AC-360-3	114.50
AC-108	12.50	AC-251	29.25	AC-375	104.00
AC-113	9.50	AC-270	67.00	AC-384	110.25
AC-114	9.50	AC-275	67.00	AC-385	38.75
AC-117	12.50	AC-280	11.00	AC-400	199.50
AC-120	22.75	AC-282	11.00	AC-435	23.25
AC-126	12.50	AC-285	6.95	AC-437	23.25
AC-130	47.50	AC-290	15.75	AC-2189	17.75
AC-143-1	59.50	AC-295	77.25	AC-2196	11.75
AC-152	30.25	AC-298	75.75	AC-2296	72.25

ALL PRICES F.O.B. FACTORY

** For 1/8" and larger. Consult factory for prices on sizes below 1/8".

† Add \$100.00 for factory boring, counterboring and facing.

*SUGGESTED LIST PRICE

SUGGESTED PRICE LIST

MAY 10, 1966

LATHE ACCESSORIES (Continued)

ITEM No.	*LIST PRICE	ITEM No.	*LIST PRICE	ITEM No.	*LIST PRICE
LA-LB Series					
LA-3-1	\$ 57.50	LA-187	\$ 3.00	LA-1065	\$ 65.00
LA-12-2	6.25	LA-344	10.00	LA-1072	73.50
LA-25-1	73.50	LA-774-1	10.50	LA-1078	78.75
LA-29-1	44.75	LA-775-1	10.50	LA-1108	75.25
LA-29-1-L	55.25	LA-958-1	120.75	LA-1200-1	115.50
LA-32-34	173.25	LA-959-1	118.25	LB-192	71.50
LA-49-5	58.00	LA-1008	12.00	LB-240	10.50
LA-70	325.00	LA-1009	7.25		
LA-170	6.00	LA-1050-1	51.00		

ELECTRIC MOTORS

1101	38.00	1116	61.00	1123DB	220.85
1105	48.00	1118	61.00	1124	161.85
1106	48.00	1120	76.00	1124DB	263.25
1110	46.00	1122	112.50	1125	192.50
1111	46.00	1122DB	205.50	1125DB	308.30
1114	122.50	1123	120.50		

MOTOR SWITCHES AND MOTOR CONTROLS

0388	35.00	6350	110.00	6355DB	145.00
0391	17.00	6350DB	135.00	6355-T	147.00
0408	35.00	6350-T	137.00	6355DB-T	172.00
2325	20.00	6350DB-T	162.00	AC-115	11.50
2330	49.00	6355	120.00		

SAFETY BRAKES AND POWER CONTROLS

J-101	106.50	J-105	92.50	J-110	229.50
J-102	133.50	J-106	106.50	J-111	239.50
J-103	92.50	J-107	133.50	J-139	87.50
J-104	202.50	J-108	212.50	J-140	101.50
				J-141	128.50

LOGAN 8" SHAPERS

■ ES8-S½	937.00	■ ES8-T¾	950.00	■ ES8-S¾	950.00
■ ES8-T½	937.00				

SHAPER ACCESSORIES

540	9.53	80249	55.00	80280	5.75
541	9.68	80260	.80	80281	5.75
560	2.25	80261	1.00	80355	.50
80199	69.50	80275	10.75		

ALL PRICES F.O.B. FACTORY

PRICES SUBJECT TO CHANGE. SHIPMENTS WILL BE BILLED AT PRICES IN EFFECT AT TIME OF SHIPMENT

LOGAN ENGINEERING CO.

4901 West Lawrence Ave. • Chicago, Illinois 60630