

4. COLUMN
5. TABLE
6. TABLE ARM
7. LOOSE PULLEY
8. TIGHT PULLEY
9. LOWER CONE
10. LOWER CONE SHAFT
12. UPPER CONE
13. CLUTCH GEAR
14. CHAIN
15. SHEAVE PLAIN
16. NUT FOR SCREW
17. BALANCE WEIGHT
18. HANDWHEEL
19. CROWN GEAR GUARD
20. WRENCH
21. WRENCH FOR TABLE ARM
22. COUNTERSHAFT BRACKET
23. SHIFTER FORK
24. LEVER REST
25. DOG
26. SHIFTER ROD GUIDE
27. SHIFTER ROD COUPLING
28. FOOT SHIFTER
30. FEED BRACKET
31. FEED WORM
32. LEVER SOCKET
33. FEED WORM
34. CROWN GEAR
35. FEED BRACKET
36. AUTO STOP COLLAR
38. WORM GEAR
39. FEED CONE
42. COLLAR
43. AUTO STOP DOG
44. SLIDING CLUTCH TOP SHAFT
45. RACK PINION
46. DRIVE PINION
47. DOUBLE BACK GEAR
48. FEED BOX
49. SLIDING CLUTCH FEED
50. COLLAR
51. SHIFTER LEVER
52. COUPLING
54. SCREW BRACKET
57. COLLAR
59. STEEL WASHER
60. SPINDLE COLLAR
61. SHIFTER FINGER
63. SLIDING BEVEL GEAR
64. SINGLE BACK GEAR
65. WORM
68. FIBRE WASHER
69. SPRING
70. SPRING
71. PLUNGER
72. MITRE FEED GEAR
74. LEVER
81. HINGE PIN
82. CONE SHAFT
87. QUICK RETURN LEVER
88. RACK
89. SPINDLE SLEEVE
90. BACK GEAR SHAFT
91. HAND LEVER
93. VERTICAL FEED SHAFT
94. WORM SHAFT
95. SHAFT FOR FEED PINION
101. TABLE ELEVATING SCREW
102. SPINDLE
105. CHAIN EYE
106. SINGLE CLUTCH
107. O.C. BUSHING
110. SHIFTER FINGER
111. SHIFTER ROD
125. LOWER FEED CONE
129. BALL THRUSTOR BEARING
131. BACK GEAR GUARD - LEFT
132. BACK GEAR GUARD - RIGHT
140. SHOULDER BOLT
271. UPPER CONE SHAFT
326. MITRE GEAR ON ELEVATING SCREW
327. MITRE GEAR ON ELEVATING CRANK
975. BASE

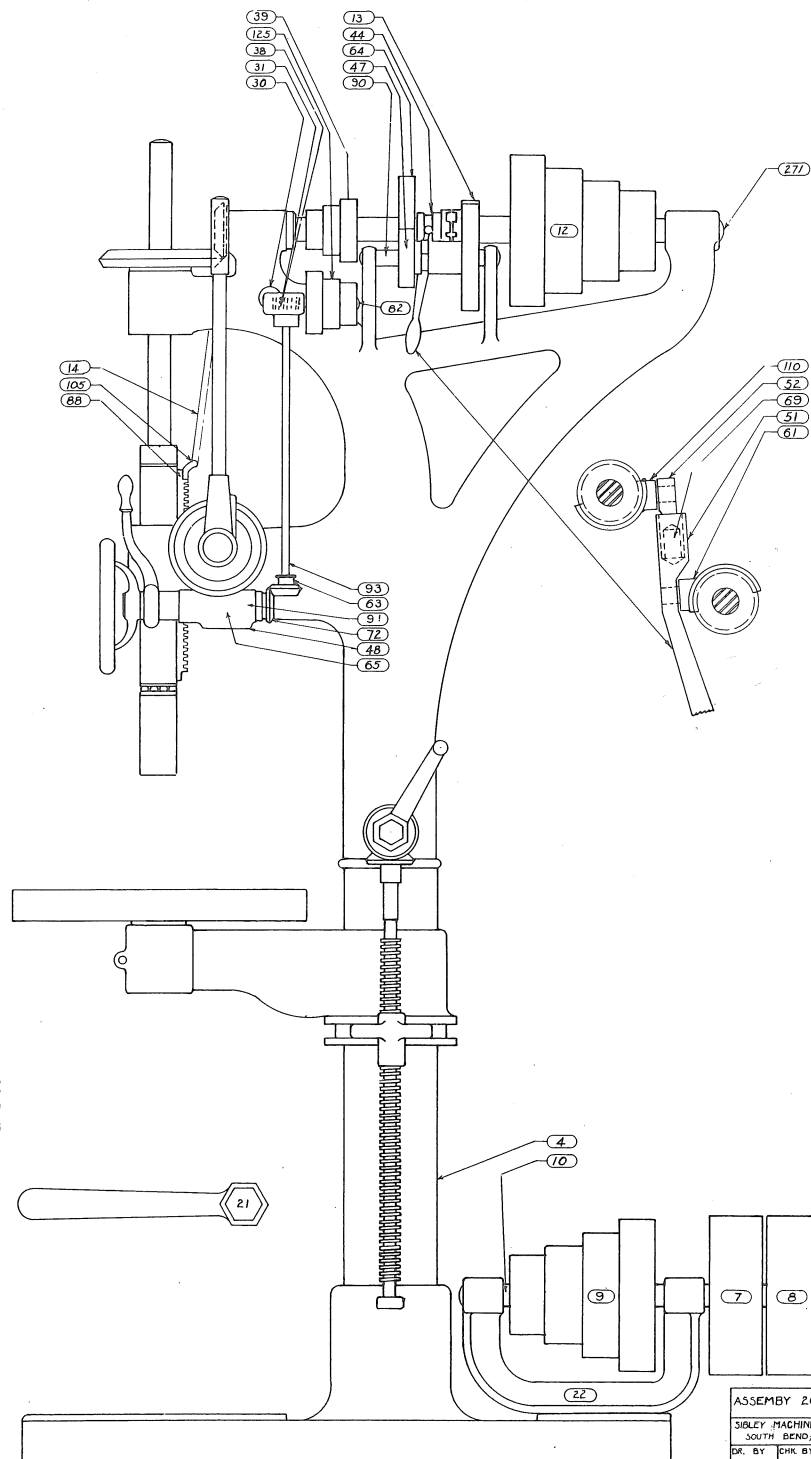

ASSEMBLY 20" COMPLETE DRILL
 SIBLEY MACHINE & FOUNDRY CORP.
 SOUTH BEND, INDIANA, U.S.A.
 DR. BY *JMS* CHK BY
 6-18-38

1581-OS

"OLD STYLE 20 IN DRILL" - PRIOR TO S/N 7603