

South Bend LATHES

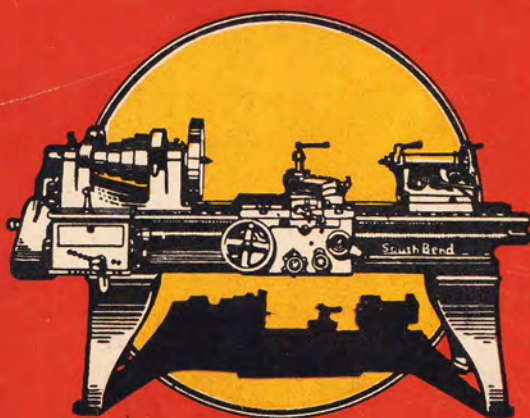

The New Model South Bend Lathe

Easy Payment Plan
Catalog No. 90-P

South Bend Lathe Works

425 East Madison Street
South Bend, Indiana, U. S. A.

Net Prices

F. O. B. South Bend, Indiana

The prices shown in this catalog are net F. O. B. cars South Bend, Indiana. In setting the prices on each lathe, tool and attachment shown, we have made the lowest possible price. Our policy is, **One Quality, One Price** to all whether you purchase one lathe or a number of lathes.

*For Easy Payment Plan See pages
82 to 85*

Guarantee

WE GUARANTEE every South Bend Lathe to be accurate and mechanically perfect; to give you entire satisfaction and the service you have a right to expect.

We will replace, free of charge, any part that proves defective, either in material or workmanship, within one year from the date of purchase.

We will ship a South Bend Lathe anywhere in the United States for a thirty day trial in your own shop. If you are dissatisfied in any way, within that time, ship it back to us; we will pay the return freight charges and refund your money.

SOUTH BEND LATHE WORKS

More Than 44,000 South Bend Lathe Users

For Index see page 96

New Model South Bend Back Geared Screw Cutting Lathes

for use in the

Manufacturing Plant	Machine Shop
Tool Room	Service Station
General Repair Shop	Electrical Shop
Engineering Shop	Laboratory
and Industries of all kinds.	

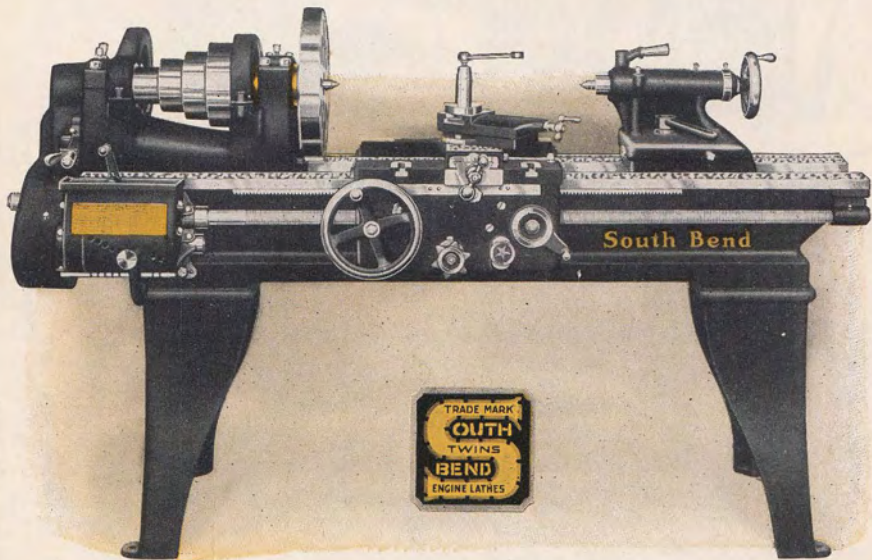

Catalog No. 90-P ~ ~ June ~ 1929

Easy Payment Plan

Described on pages 82 to 85.

Any of the 96 sizes and types of New Model South Bend Lathes, chucks, tools and attachments illustrated in this Catalog can be purchased on the South Bend Easy Payment Plan. Terms: 20% cash down payment with order, balance in 12 equal monthly payments.

South Bend Lathe Works

425 East Madison St., South Bend, Ind., U. S. A.

Printed in U. S. A.

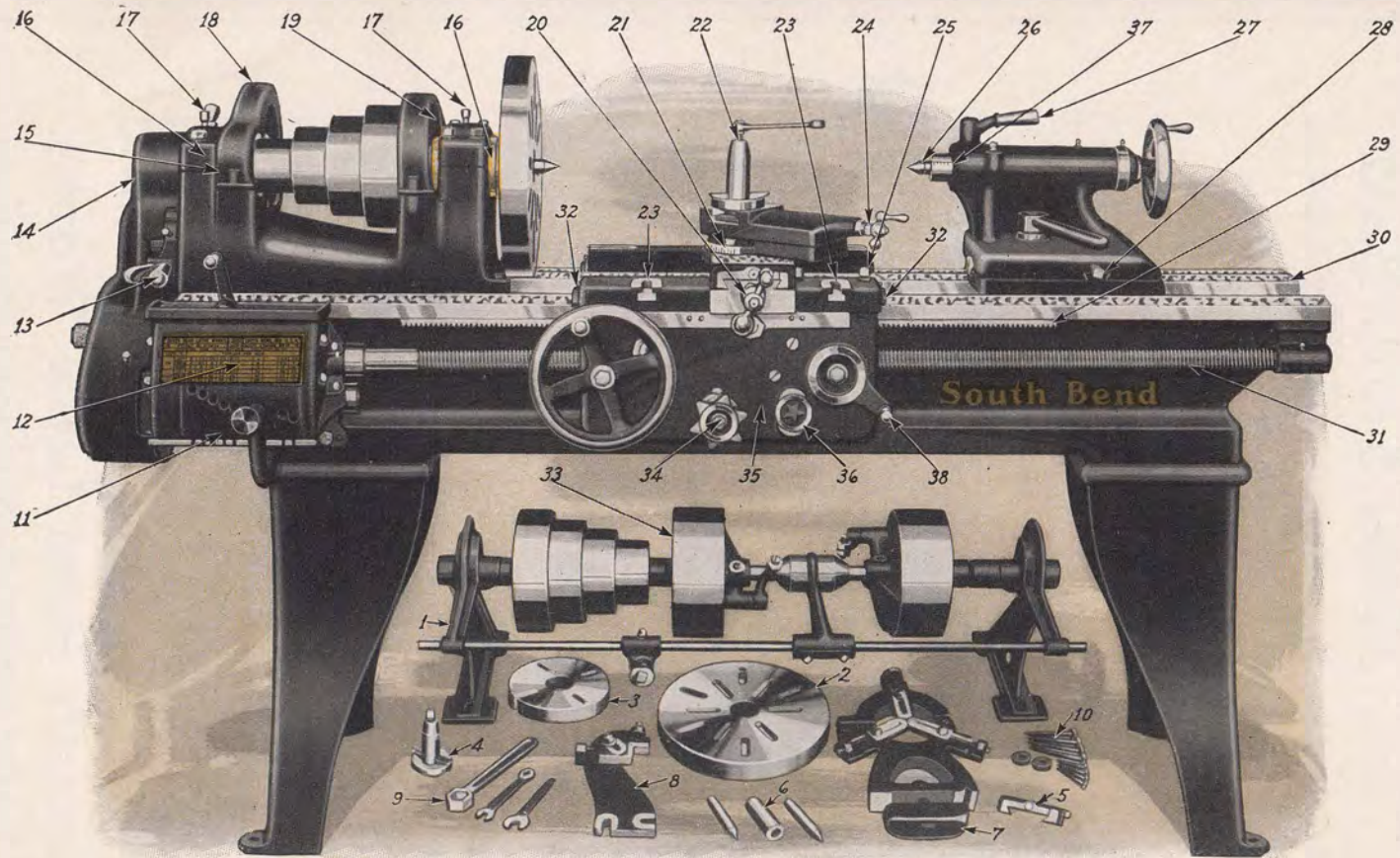

The Basic Design and Principal Features of All Types of New Model South Bend Lathes

- | | | | |
|--|---|---|--|
| <p>11—Quick Change Gear Box.
 12—Index Plate for Threads and Feeds.
 13—Quick-acting Latch Reverse.
 14—Special Carbon Steel Hollow Spindle.
 15—Hardened and Ground Steel Thrust Collar.
 16—Large Phosphor Bronze Bearings.
 17—Patent Oil Cups.</p> | <p>18—Back Gears well guarded.
 19—Wrenchless Bull Gear Clamp.
 20—Micrometer Collar on Cross Feed Screw.
 21—Compound Rest graduated 180 degrees.
 22—Forged Steel Adjustable Tool Post.
 23—"T" Slot for clamping work on Carriage.
 24—Micrometer Collar on Compound Rest Screw.</p> | <p>25—Carriage Lock for facing.
 26—Tool Steel Lathe Centers.
 27—Tailstock Spindle Lock.
 28—Set-over Tailstock for taper turning.
 29—Steel Rack, cut from the solid.
 30—Semi-steel seasoned Lathe Bed.
 31—Precision Lead Screw, Acme Thread.</p> | <p>32—Felt Shear Wipers and Oilers.
 33—Double Friction Countershaft. See Page 52.
 34—Automatic Friction Feed Clutch.
 35—Safety Device for Threads and Feeds.
 36—Knob for Automatic Feed.
 37—Graduated Tailstock Spindle.
 38—Half-nut Lever for Thread Cutting.</p> |
|--|---|---|--|

The New Model South Bend Lathe

The New Model South Bend Back Geared Screw Cutting Lathe is built for the working of metals, in industry, manufacturing, tool room, machine shop, mine, textile mill, railroad shop, and in all shops where accurate machine work is desired. The New Model Lathe is a development of 23 years' experience in lathe building. Each of the 352 parts of the lathe has been improved.

Features of the New Model South Bend Lathe

The illustration of the New Model South Bend Back Geared Screw Cutting Lathe on the opposite page shows the basic design of all New Model South Bend Lathes. The headstock, tailstock, carriage, apron, lead screw, etc., (differing only in dimensions for different sizes of lathes) are units that are used on each type of lathe shown in this catalog. The description of the lathe on this page applies to all types of New Model Lathes.



The Lathe Bed is a close grained casting of gray iron and steel mixture, containing 18 per cent steel, which gives it strength and wearing qualities. The bed is reinforced by box braces cast in at short intervals its entire length. The lathe beds are rough planed and thoroughly seasoned, then finish planed. The bed has three "V" ways and one flat way for aligning the carriage, headstock and tailstock.

The Headstock Unit is ruggedly constructed and scientifically braced to insure permanent alignment of the spindle bearings. It is equipped with a Quick Acting Reverse Lever for changing the direction of the automatic feeds. The gears are completely covered to comply with all State laws. A Quick Acting Bull Gear Clamp permits engaging or disengaging the back gears without the use of a wrench. See page 6.

The Four-Step Spindle Cone is used on all New Model Lathes, 13-inch size and larger, because of the wide speed range it provides. This feature is of prime importance in manufacturing because of the wide variety of work done on the lathe. The Three-Step Cone provides ample speed range on the smaller sizes. The Cone Pulley and Bull Gear are accurately balanced so that the lathe can be operated at high speed with the open belt on the smaller steps for finishing cuts, drilling, polishing, machining brass, aluminum, etc., without danger of vibration. The larger steps provide intermediate speeds for general work. The back gears furnish the slow speeds and power required for the heaviest roughing cuts.

The New Headstock Spindle is made of a special quality carbon spindle steel. It has a hole its entire length for machining rods and bars through the lathe chuck and draw-in collet chuck. Both of the spindle bearings are ground and are seated in phosphor bronze boxes of unusual strength. The steel thrust collar is hardened and ground. See page 8.

The Phosphor Bronze Bearings for the headstock spindle are of best quality—designed for heavy duty work and are adjustable for wear. The bearings are hand scraped to the



Features of the New Model South Bend Lathe

(Continued)

spindle insuring a perfect fit. Patent oil cups lubricate the spindle and prevent dust and grit from working into the bearings. See page 8.

The Tailstock is heavy and has a long bearing on the lathe bed. It has a set-over for taper turning. It is designed to allow the compound rest to swivel parallel to the bed. The tailstock spindle is graduated in 16ths of an inch. A binding lever locks the tailstock spindle without disturbing the alignment.

The Carriage has a wide bridge and long bearings on the "V" ways of the bed. On the 13-inch size and larger it has "T" slots for clamping work for boring and reaming. The carriage is hand scraped to the lathe bed. Felt shear wipers keep the "V" ways oiled and clean. The cross feed screw has an Acme Thread and a micrometer graduated collar reading in 1/1000 of an inch. The back of the carriage is machined to receive the taper attachment. A locking device fastens the carriage to the bed when using cross feed.

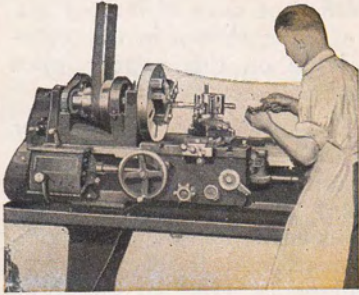

The Apron is provided with automatic friction cross feed and automatic friction longitudinal feed. The Apron is also provided with a double bracket which supports the steel feed worm. The Apron contains the half-nuts which are gibbed and scraped to a perfect bearing. An automatic safety interlock prevents the half-nuts and automatic feeds from being engaged at the same time. The half-nuts are used for screw thread cutting only and have no connection with the automatic cross or longitudinal feeds which are operated by the spline in the lead screw. See page 7.

The Precision Lead Screw is made of special steel and has Acme Thread cut on a special machine equipped with a Pratt & Whitney master lead screw. The lead screw is tested for form of thread and accuracy of lead and is guaranteed to meet the most exacting requirements in cutting the finest precision thread gauges, master taps and dies and on all work where accuracy is essential. The Lead Screw is splined which enables it to serve as a feed rod for operating the automatic friction cross and longitudinal feeds. **The threads of the Lead Screw are used only for cutting screw threads** and not for operating the automatic feeds. The threads of the lead screw should last a lifetime. See page 7.

The Compound Rest is graduated in degrees reading from 0 to 90° from center to each extremity of the arc. It swivels on a central stud and can be clamped and operated at any angle, and has an angular travel. The compound rest screw has Acme Thread and a micrometer collar graduated in 1/1000 of an inch. See page 6.

The New Quick Change Gear Box provides forty-eight changes for cutting right or left hand standard screw threads from 2 to 112 per inch. It also provides for various adjustments of the automatic cross feed and automatic longitudinal feed. This is the Flather Patent Quick Change Gear Box which has no superior in any back geared screw cutting lathe built. The index plate shows the arrangement of levers on the gear box for cutting screw threads and operating the automatic feeds. See page 5.



Mechanical Features of South Bend Lathes

Quick Change Gear Box

On the New Model Quick Change Gear Lathes

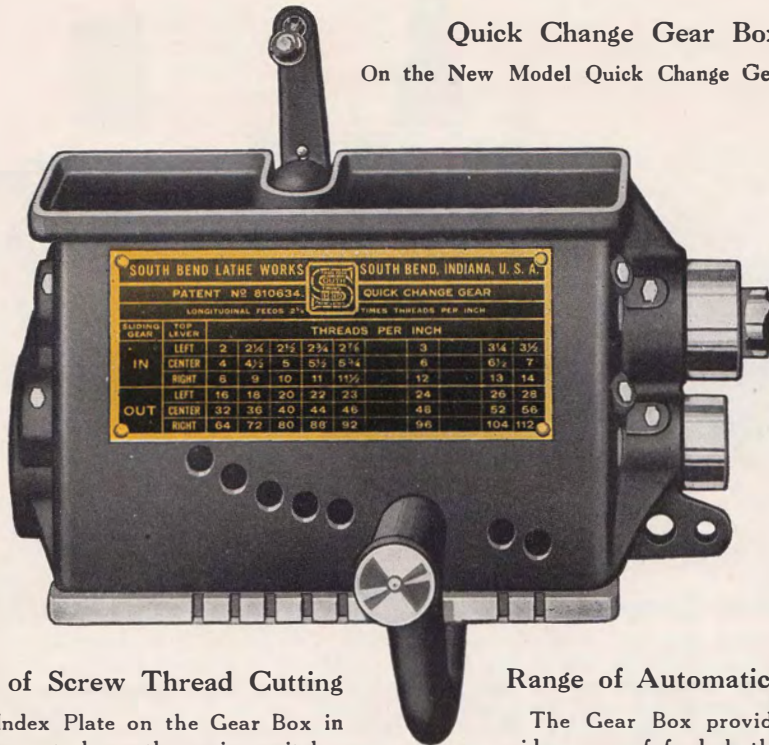

SOUTH BEND LATHE WORKS		SOUTH BEND, INDIANA, U. S. A.											
PATENT NO 810634.		QUICK CHANGE GEAR											
LONGITUDINAL FEEDS 2"		FINER THREADS PER INCH											
SLIDING GEAR	TOP RIVER	THREADS PER INCH											
IN	LEFT	2	2½	2½	2¾	2 7/8	3	3¼	3½				
	CENTER	4	4½	5	5½	5¾	6	6½	7				
	RIGHT	8	9	10	11	11½	12	13	14				
OUT	LEFT	16	18	20	22	23	24	26	28				
	CENTER	32	36	40	44	46	48	52	56				
	RIGHT	64	72	80	88	92	96	104	112				

Range of Screw Thread Cutting

The Index Plate on the Gear Box in the above cut shows the various pitches of threads that can be cut on South Bend Lathes. A range of 48 screw threads, right or left, from 2 to 112 pitch including 11½ pipe thread, can be cut without removing a gear. One of these metal Index Plates is attached to each New Model South Bend Quick Change Gear Lathe in all sizes from 9-inch to 18-inch inclusive both in Countershaft Drive and in all types of Motor Drive.

Range of Automatic Feeds

The Gear Box provides for a wide range of feeds both fine and coarse for the Automatic Longitudinal Feed and the Automatic Cross Feed. All these feeds can be adjusted without removing a gear.

Easy to Operate

The Quick Change Gear Box of the New South Bend Lathe is one of the most complete, compact and best designed on the market. It is simple, accurate, durable and easy to operate. The operation of the Quick Change Gear Box is fully explained in the book entitled "How to Run a Lathe," which is included with the equipment.

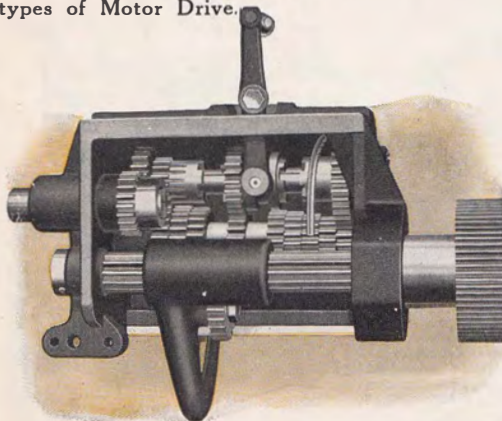

Interior View of Gear Box

Interior View of Gear Box

A group of eight steel gears is mounted on the center shaft, any one of which can be instantly engaged with the Lead Screw. The Tumbler Lever and the small Top Lever enable the operator to obtain 24 changes. By sliding the knob at the end of the lathe the number of changes is doubled, making 48 in all.

Mechanical Features of South Bend Lathes

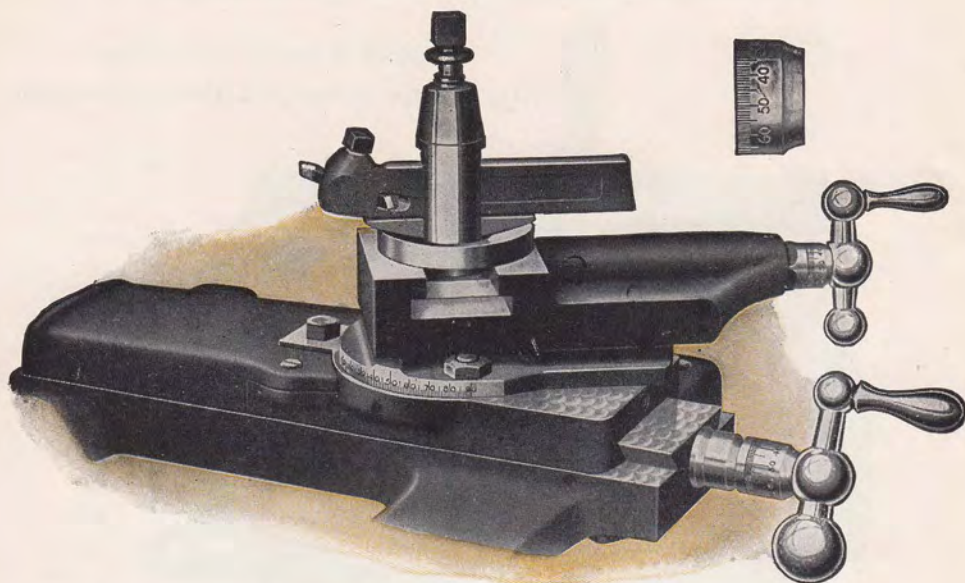

Graduated Compound Rest on all New Model South Bend Lathes

The illustration above shows the Compound Rest mounted on the saddle of the lathe, to show the advantage of the two feed screws—the compound rest screw and the cross feed screw of the saddle. The Compound Rest is used in turning or boring short tapers or bevels.

The Compound Rest Screw and the Cross Feed Screw permit the operator to do all kinds of straight or taper work because in combination these two screws permit the cutting tool to be fed in any direction.

The Compound Rest base is accurately graduated in degrees over an arc of 180° reading 0 to 90° from center to each extremity of the arc. It turns on a large central stud and can be rigidly clamped in any position after setting.

The Compound Rest Feed Screw and the Cross Feed Screw of the Saddle are both coarse Acme Thread and each has a micrometer graduated collar reading in one-thousandths of an inch for regulating the depth of the cut.

Headstock and Tailstock on New Model South Bend Lathes

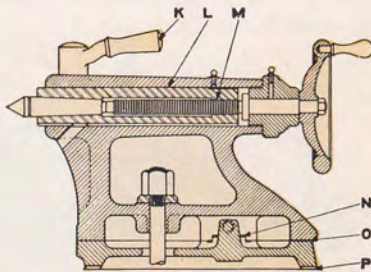
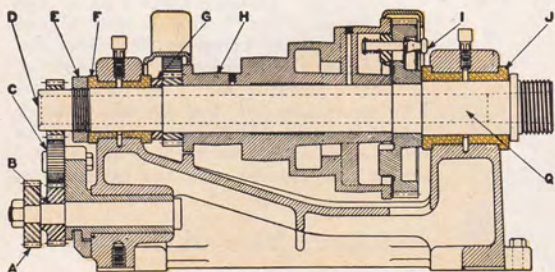

Principal Parts of Headstock and Tailstock

For all sizes and types of New Model Lathes

- A—Steel Stud Gear
- B—Extra Long Reverse Shaft
- C—Quick Acting Reverse, All Gears Steel
- D—Hole Through Headstock Spindle
- E—Take-up Nut for End Play
- F—Bronze Spindle Bearings
- G—Hardened, Ground Steel Thrust Collar
- H—Balanced Cone Pulley
- I—Wrenchless Bull Gear Clamp

- J—Phosphor Bronze Bearings
- K—Improved Tail Spindle Lock
- L—Steel Tailstock Spindle
- M—Acme Thread Tailstock Screw
- N—Set-over for Taper Turning
- O—Tailstock Top Accurately Hand Scraped to Base
- P—Tailstock Base Hand Scraped to Bed
- Q—Special Carbon Steel Hollow Spindle



Graduated Tailstock Spindle

Mechanical Features of South Bend Lathes

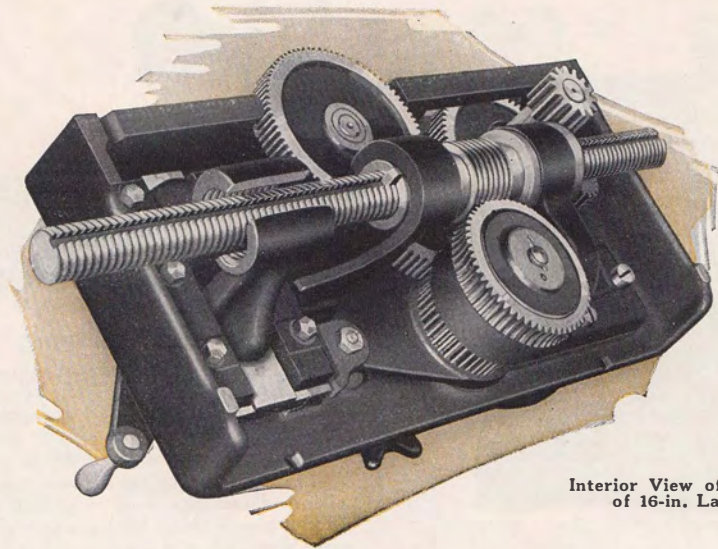

Interior View of Apron
of 16-in. Lathe

Apron and Lead Screw on the New Model South Bend Lathe

For Quick Change and Standard Change Gear Lathes

The New Apron

The Apron of the New Model South Bend Lathe is a marvel of power and simplicity. The above illustration of the Apron shows the double worm bracket which supports the steel worm while it is in operation. This is a valuable feature which explains the cutting power of the New Model South Bend Lathe.

Automatic Feeds

The Lead Screw is splined which permits it to serve as a feed rod for operating the Automatic Cross Feed and Automatic Longitudinal Feed of the Lathe. See illustration of interior of the Apron shown above.

The Splined Lead Screw makes a positive drive feed rod as it is geared direct to the spindle and permits a variety of automatic feed changes.

Automatic Safety Device

The Automatic Safety Device in the Apron prevents the Automatic Feeds from being placed in action while the half nuts are clamped on the Lead Screw for cutting screw threads, and vice versa, prevents the half nuts from being clamped on the Lead Screw while either of the Automatic Feeds are in action. When one feed is engaged the others are locked.

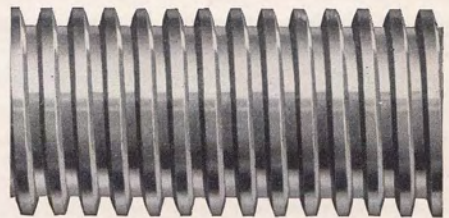

Acme Thread Lead Screw

Section of the Lead Screw for the 16-inch New Model Lathe. It is $1\frac{1}{8}$ inches in diameter. 6 pitch—the illustration is actual size.

The New Lead Screws are made of steel, have coarse pitch Acme Thread and are cut with precision and accuracy on a special machine equipped with a Pratt and Whitney Master Lead Screw which insures accuracy.

Threads of Lead Screw Used Only

When Cutting Screw Threads

The Threads of the Lead Screw are used only when cutting screw threads. The threads of the Lead Screw are not used for operating the Automatic Cross Feed or the Automatic Longitudinal Feed. The Lead Screw of the Lathe should last a lifetime.

Mechanical Features of South Bend Lathes

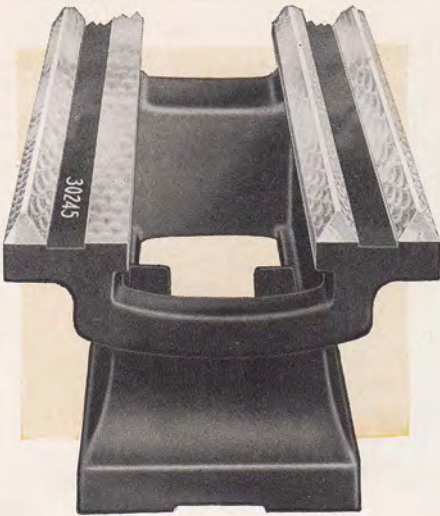

Lathe Beds

Machining, Seasoning and Scraping

The Lathe Bed is made of a hard, close-grained gray iron with 18 per cent steel mixture which resists wear. Note the heavy cross braces which are cast in at short intervals of the bed. Three "V" ways and one flat way afford large bearing surface for the carriage, headstock and tailstock.

After rough machining, the lathe beds are thoroughly seasoned, then they are finish machined and hand scraped.



Hand Scraping Tailstock Base to Lathe Bed

Hand Scraping

The Lathe Units, for all sizes of South Bend Lathes, such as bed, headstock, tailstock, saddle, apron, and compound rest, in addition to being machined, are all hand scraped where a sliding fit is necessary.

This hand scraping insures accuracy, precision, durability and long life. The New Model South Bend Lathe when given proper care should last a lifetime.

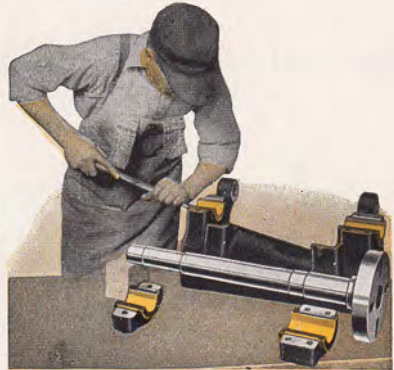

Scraping Bronze Bearings to Receive the Spindle

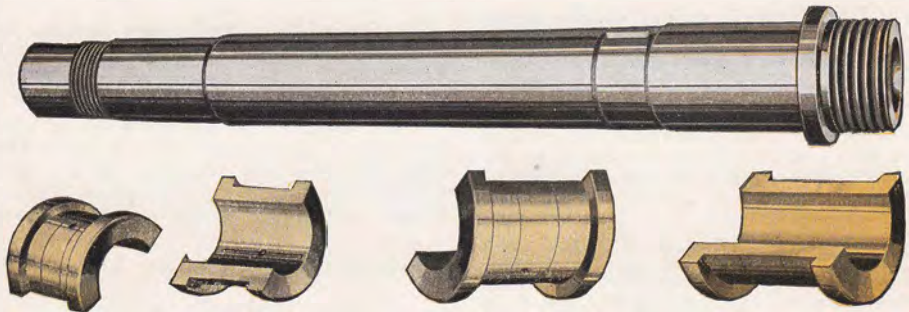

Steel Headstock Spindle and Phosphor Bronze Bearings

For all sizes and types of New Model South Bend Lathes

The Headstock Spindle is made of high carbon steel finished ground on all diameters with a hole through its entire length.

The Phosphor Bronze Head Spindle Bearings, front and rear, are hand scraped to a perfect bearing.

Accuracy Tests of South Bend Lathes

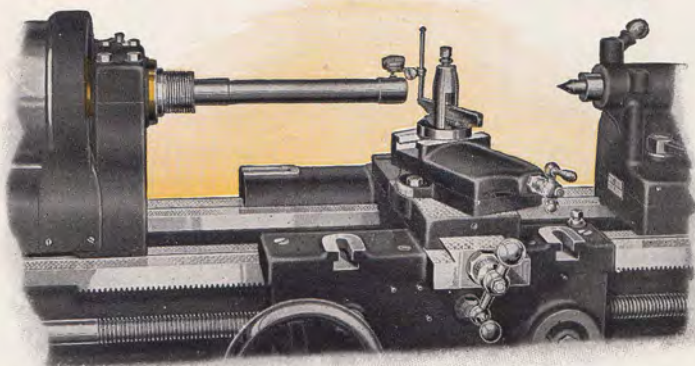

Testing Headstock Spindle with Test Bar and Test Indicator

Testing Alignment of Spindle

The illustration above shows the spindle alignment test which is one of the 64 major accuracy tests which each South Bend Lathe is given. The test bar varies from 12 inches to 18 inches long, depending upon the size of the lathe. It is hardened and ground all over and fits into the taper of the spindle.

Dial Test Indicator



A dial test indicator is fastened in the Tool Post. The face of this dial is so graduated that it will record an error of one ten-thousandth of an inch. Tests of this kind enable us to build lathes that are accurate in every detail.



Testing the Cross-Slide

This test insures the axis of the Lathe Spindle being perpendicular and at right angles with the Cross-Slide of the Saddle.

Sixty-four Accuracy Tests

Most of the 64 accuracy tests on the South Bend Lathe are made during the process of manufacture. For example: When boring Headstock bearings, every Headstock is tested as it comes from the machine to see that it is bored accurately. Similar tests are made on the Tailstock, Carriage, Saddle and other units.

Factory Test Card

FACTORY TEST CARD OF SOUTH BEND LATHE	
Size of Lathe <i>16 X 8</i> Cat. No. <i>92-C</i>	
Type of Lathe <i>O.C. & L.</i> Serial No. <i>38361</i>	
Type of Drive <i>C-shaft</i> Type of Bed <i>Straight</i>	
TESTS	
HEAD STOCK SPINDLE TAPER	Test Record
Outer end of 12" Test Bar runs true	<i>.0002"</i>
12" Test Bar Parallel with Lathe Bed	<i>.000</i>
TAIL STOCK SPINDLE	
Parallel with Lathe Bed	<i>.0005"</i>
CENTERS	
Alignment	<i>.0005"</i>
FACE PLATE	
Concave	<i>.0005"</i>
CHUCK	
Tests	<i>OK</i>
LEAD SCREW	
Final lead test	<i>OK</i>
SADDLE	
Bearing on cross slide	<i>OK</i>
Bearing on Lathe Bed	<i>OK</i>
COUNTERSHAFT	
Clutch test	<i>OK</i>
Assembled by <i>H. J. Lambert</i> 3/14/27	
Tested by <i>R. S. Young</i> 3/16/27	
SOUTH BEND LATHE WORKS	

The Factory Test Card records the principal tests made on each lathe before it leaves the factory.

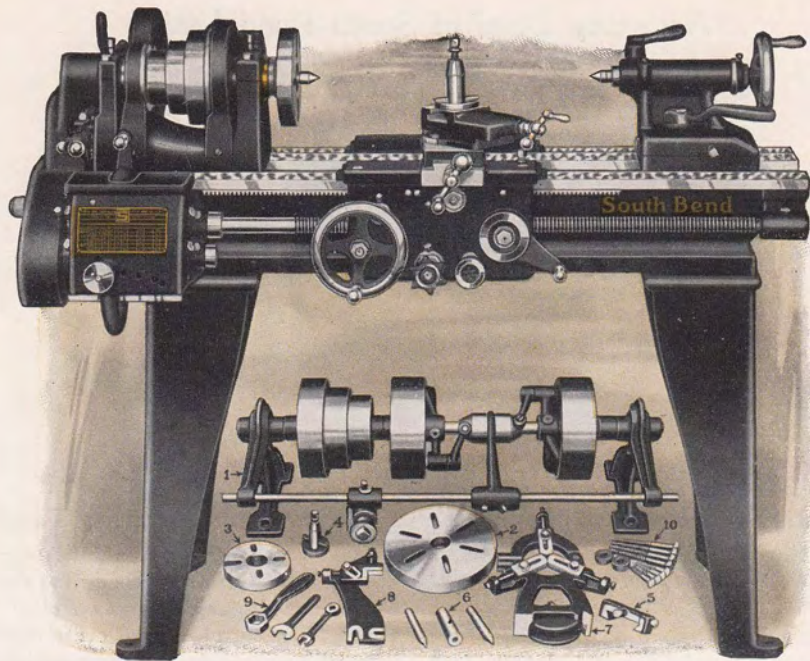

Regular equipment, as illustrated under Lathe, is included in price of Lathe

9-inch Quick Change Gear New Model South Bend Lathe

Back Geared, Screw Cutting Precision Lathe, Countershaft Drive

The New Model 9-inch Quick Change Back Geared Screw Cutting Precision Lathe is for the shop where light, accurate work is taken care of. It is capable of turning out work of the finest accuracy and precision.

The New Headstock is back geared, reinforced and webbed, insuring strength and rigidity. Six spindle speeds are provided, three direct and three back geared. See page 6.

The Headstock Spindle is made of high carbon steel finished ground with a $\frac{3}{4}$ -inch hole its entire length. See page 8.

The Phosphor Bronze Bearings for Head Spindle are hand scraped to a perfect bearing, are adjustable for wear and are equipped with oilers. See page 8.

The Quick Change Gear Box provides 48 changes for cutting right or left hand screw threads from 2 to 112 per inch without removing a gear. An index plate shows the arrangement for cutting the following threads: 2, 2 $\frac{1}{2}$, 2 $\frac{3}{4}$, 2 $\frac{7}{8}$, 3, 3 $\frac{1}{4}$, 3 $\frac{1}{2}$, 4, 4 $\frac{1}{2}$, 5, 5 $\frac{1}{2}$, 5 $\frac{3}{4}$, 6, 6 $\frac{1}{2}$, 7, 8, 9, 10, 11, 11 $\frac{1}{2}$, 12, 13, 14, 16, 18, 20, 22, 23, 24, 26, 28, 32, 36, 40, 44, 46, 48, 52, 56, 64, 72, 80, 88, 92, 96, 104, 112. See page 5.

LATHE FEATURES

Full quick change gear mechanism.
Back geared headstock gives 6 spindle speeds.
Automatic cross feed, automatic longitudinal feed.
Hollow spindle made of special carbon steel.
Spring latch reverse for feeds and threads.
Phosphor bronze bearings for spindle.
Graduated compound rest swivels to any angle.
Tailstock is arranged for set over for taper turning.
Graduated collar on cross feed and compound rest screws.
Precision lead screw for cutting accurate threads.

The New Tailstock has a set-over for taper turning. The binding lever locks the spindle without disturbing the alignment of centers. The center is hardened. See page 6.

The New Apron has automatic cross and longitudinal feeds, and half nuts for thread cutting. An automatic safety interlock prevents the half nuts and automatic feeds from being engaged at the same time. See page 7.

The Precision Lead Screw, $\frac{3}{4}$ -inch diam., 8 threads per inch Acme Standard, is cut on a special machine equipped with a master lead screw which insures accuracy. The threads of the lead screw are used for thread cutting only as the spline in the lead screw drives a worm in the apron which operates both automatic feeds. See page 7.

The Regular Equipment included with each 9-inch Quick Change Gear Lathe consists of: Double Friction Countershaft, Large Face Plate, Small Face Plate, Tool Post Complete, Adjustable Thread Cutting Stop, Two Lathe Centers and Spindle Sleeve, Center Rest, Follower Rest and Wrenches. See pages 52 and 53.

LATHE SPECIFICATIONS

Head and Tail Spindle Centers.....No. 2, Morse Taper
Size of Spindle Nose.....1 $\frac{1}{2}$ in. diam., 8 Threads
Precision Acme Lead Screw..... $\frac{3}{4}$ in. diam., 8 Threads
Screw Thread Cutting Range.....2 to 112 per inch
Width of Cone Pulley Belt.....1 in.
Spindle Speeds.....40, 75, 128, 246, 410, 700 R.P.M.
Countershaft Speed.....300 R.P.M.
Countershaft Friction Clutch Pulleys.....6 $\frac{7}{8}$ in. x 2 $\frac{3}{8}$ in.
Angular Travel of Compound Rest Top.....1 $\frac{1}{2}$ in.
Size of Lathe Tool Shank..... $\frac{3}{8}$ in. x $\frac{1}{2}$ in.

Easy Payment Prices 9-inch Quick Change Gear Lathe Including Overhead Countershaft and Equipment

Catalog No. of Lathe	Swing Over Bed	Length of Bed	Between Centers	Hole Thru Spindle	Swing Over Carriage	Power Required	Weight Crated	Code Word	Price F.O.B. South Bend	Down Payment 20%	12 Equal Monthly Payments
82-X	9 $\frac{1}{4}$ in.	2 $\frac{1}{2}$ ft.	11 in.	$\frac{3}{4}$ in.	6 $\frac{3}{8}$ in.	$\frac{1}{4}$ H.P.	470 lbs.	Babit	\$288.00	\$57.60	\$20.16
82-Y	9 $\frac{1}{4}$ in.	3 ft.	18 in.	$\frac{3}{4}$ in.	6 $\frac{3}{8}$ in.	$\frac{3}{8}$ H.P.	490 lbs.	Becke	294.00	58.80	20.58
82-Z	9 $\frac{1}{4}$ in.	3 $\frac{1}{2}$ ft.	23 in.	$\frac{3}{4}$ in.	6 $\frac{3}{8}$ in.	$\frac{1}{2}$ H.P.	510 lbs.	Bikes	300.00	60.00	21.00
82-A	9 $\frac{1}{4}$ in.	4 ft.	29 in.	$\frac{3}{4}$ in.	6 $\frac{3}{8}$ in.	$\frac{3}{4}$ H.P.	530 lbs.	Blody	307.00	61.40	21.49
82-R	9 $\frac{1}{4}$ in.	4 $\frac{1}{2}$ ft.	36 in.	$\frac{3}{4}$ in.	6 $\frac{3}{8}$ in.	$\frac{1}{2}$ H.P.	550 lbs.	Bosco	315.00	63.00	22.05

Monthly Payments include carrying charge.

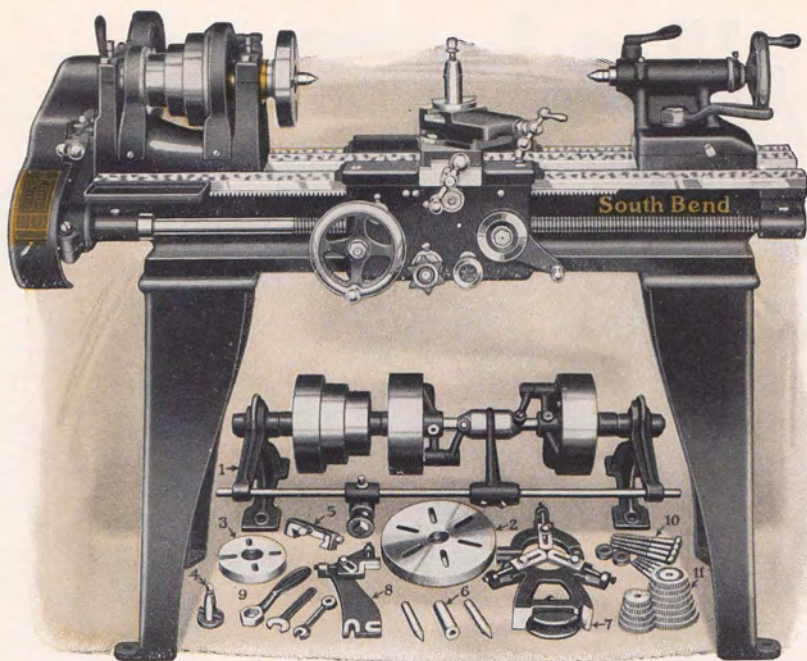

Regular equipment, as illustrated under Lathe, is included in price of Lathe

9-inch Standard Change Gear New Model South Bend Lathe

Back Geared, Screw Cutting Precision Lathe, Countershaft Drive

The New Model 9-inch Standard Change Gear Back Geared Screw Cutting Precision Lathe is a practical tool for the shop on light accurate work. It is capable of turning out work of the finest accuracy and precision.

The New Headstock is back geared, reinforced and webbed, insuring strength and rigidity. Six spindle speeds are provided, three direct and three back geared. See page 6.

The Headstock Spindle is made of high carbon steel finished ground with a $\frac{3}{4}$ -inch hole its entire length. See page 8.

The Phosphor Bronze Bearings for Head Spindle are hand scraped to a perfect bearing, are adjustable for wear and are equipped with oilers. See page 8.

The New Model Standard Change Gear Lathe is equipped with a set of independent change gears to cut the following screw threads per inch, right or left-hand, including $1\frac{1}{2}$ pipe thread: 4, 5, 6, 7, 8, 9, 10, 11, $11\frac{1}{2}$, 12, 13, 14, 16, 18, 20, 22, 24, 26, 28, 30, 32, 36 and 40. By compounding the gears furnished many other threads can be cut. See page 53.

LATHE FEATURES

Independent change gears for threads and feeds.
 Back geared headstock gives 6 spindle speeds.
 Automatic cross feed, automatic longitudinal feed.
 Hollow spindle, made of special carbon steel.
 Spring latch reverse for feeds and threads.
 Phosphor bronze bearings for spindle.
 Graduated compound rest swivels to any angle.
 Tailstock is arranged for set-over for taper turning.
 Graduated collar on cross feed and compound rest screws.
 Precision lead screw for cutting accurate threads.

The New Tail Stock has a set-over for taper turning. The binding lever locks the spindle without disturbing the alignment of centers. The center is hardened. See page 6.

The New Apron has automatic cross and longitudinal feeds, and half nuts for thread cutting. An automatic safety interlock prevents the half nuts and automatic feeds from being engaged at the same time. See page 7.

The Precision Lead Screw, $\frac{3}{4}$ -inch diam., 8 threads per inch Acme Standard, is cut on a special machine equipped with a master lead screw which insures accuracy. The threads of the lead screw are used for thread cutting only as the spline in the lead screw drives a worm in the apron which operates both automatic feeds. See page 7.

The Regular Equipment included with each 9-inch Standard Change Gear Lathe consists of: Double Friction Countershaft, Set of Independent Change Gears, Large and Small Face Plates, Tool Post Complete, Adjustable Thread Cutting Stop, two Lathe Centers and Spindle Sleeve, Center Rest, Follower Rest and Wrenches. See pages 52 and 53.

LATHE SPECIFICATIONS

Head and Tail Spindle Centers..... No. 2, Morse Taper
 Size of Spindle Nose..... $1\frac{1}{2}$ in. diam., 8 Threads
 Precision Acme Lead Screw..... $\frac{3}{4}$ in. diam., 8 Threads
 Screw Thread Cutting Range..... 4 to 40 per inch
 Width of Cone Pulley Belt..... 1 in.
 Spindle Speeds..... 40, 75, 128, 246, 410, 700 R.P.M.
 Countershaft Speed..... 300 R.P.M.
 Countershaft Friction Clutch Pulleys..... $6\frac{1}{2}$ in. x $2\frac{1}{2}$ in.
 Angular Travel of Compound Rest Top..... $1\frac{1}{2}$ in.
 Size of Lathe Tool Shank..... $\frac{1}{2}$ in. x $\frac{1}{8}$ in.

Easy Payment Prices 9-inch Standard Change Gear Lathe Including Overhead Countershaft and Equipment

Catalog No. of Lathe	Swing Over Bed	Length of Bed	Between Centers	Hole Thru Spindle	Swing Over Carriage	Power Required	Weight Crated	Code Word	Price F.O.B. South Bend	Down Payment 20%	12 Equal Monthly Payments
31-X	9 $\frac{1}{4}$ in.	2 $\frac{1}{2}$ ft.	11 in.	$\frac{3}{4}$ in.	6% in.	$\frac{1}{4}$ H.P.	460 lbs.	Brake	\$243.00	\$48.60	\$17.01
31-Y	9 $\frac{1}{4}$ in.	3 ft.	18 in.	$\frac{3}{4}$ in.	6% in.	$\frac{1}{4}$ H.P.	480 lbs.	Budis	249.00	49.80	17.43
31-Z	9 $\frac{1}{4}$ in.	3 $\frac{1}{2}$ ft.	23 in.	$\frac{3}{4}$ in.	6% in.	$\frac{1}{4}$ H.P.	500 lbs.	Bvest	255.00	51.00	17.85
31-A	9 $\frac{1}{4}$ in.	4 ft.	29 in.	$\frac{3}{4}$ in.	6% in.	$\frac{1}{4}$ H.P.	520 lbs.	Bwags	262.00	52.40	18.34
31-R	9 $\frac{1}{4}$ in.	4 $\frac{1}{2}$ ft.	36 in.	$\frac{3}{4}$ in.	6% in.	$\frac{1}{4}$ H.P.	540 lbs.	Bzeke	270.00	54.00	18.90

Monthly Payments include carrying charge.

SOUTH BEND, INDIANA, U. S. A.

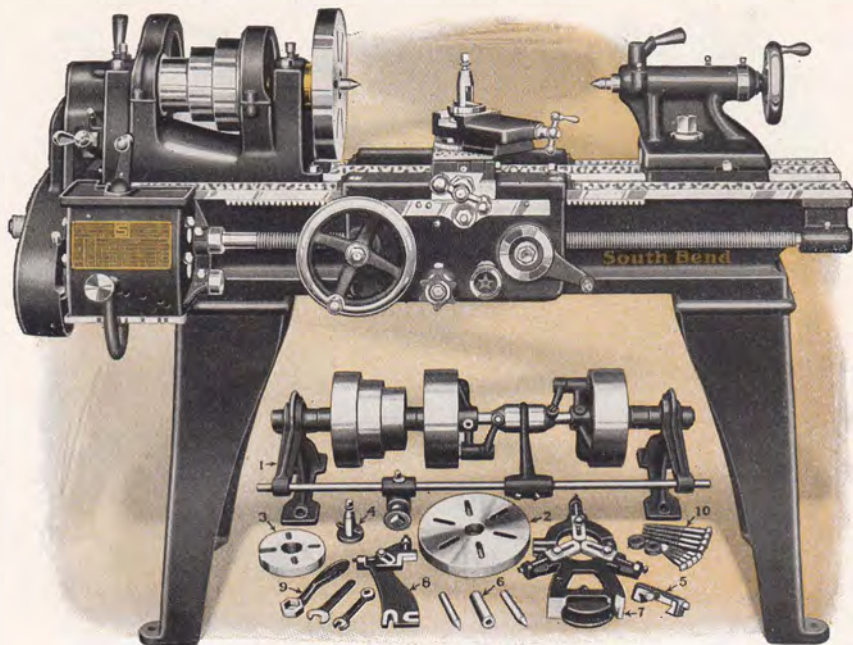

Regular equipment, as illustrated under Lathe, is included in price of Lathe

11-inch Quick Change Gear New Model South Bend Lathe

Back Geared, Screw Cutting Lathe, Countershaft Drive

The New Model 11-inch Quick Change Back Geared Screw Cutting Lathe is an excellent tool for light production work in manufacturing. It has the precision and accuracy for tool room work.

The New Headstock is back geared, reinforced and webbed, insuring strength and rigidity. Six spindle speeds are provided, three direct and three back geared. See page 6.

The Headstock Spindle is made of high carbon steel finished ground with a $\frac{7}{8}$ -inch hole its entire length. See page 8.

The Phosphor Bronze Bearings for Head Spindle are hand scraped to a perfect bearing, are adjustable for wear and are equipped with patent oilers. See page 8.

The Quick Change Gear Box provides 48 changes for cutting right or left hand screw threads from 2 to 112 per inch without removing a gear. An index plate shows the arrangement for cutting the following threads: 2, 2½, 2¾, 2¾, 2¾, 3, 3¼, 3½, 4, 4½, 5, 5½, 5¾, 6, 6½, 7, 8, 9, 10, 11, 11½, 12, 13, 14, 16, 18, 20, 22, 23, 24, 26, 28, 32, 36, 40, 44, 46, 48, 52, 56, 64, 72, 80, 88, 92, 96, 104, 112. See page 5.

LATHE FEATURES

Full quick change gear mechanism.
 Back geared headstock gives 6 spindle speeds.
 Automatic cross feed, automatic longitudinal feed.
 Hollow spindle made of special carbon steel.
 Spring latch reverse for feeds and threads.
 Phosphor bronze bearings for spindle.
 Graduated compound rest swivels to any angle.
 Tailstock is arranged for set-over for taper turning.
 Graduated collar on cross feed and compound rest screws.
 Precision lead screw for cutting accurate threads.

The New Tailstock has a set-over for taper turning. The binding lever locks the spindle without disturbing the alignment of centers. The center is hardened. See page 6.

The New Apron has automatic cross and longitudinal feeds, and half nuts for thread cutting. An automatic safety interlock prevents the half nuts and automatic feeds from being engaged at the same time. See page 7.

The Precision Lead Screw, $\frac{7}{8}$ -inch diam., 8 threads per inch Acme Standard, is cut on a special machine equipped with a master lead screw which insures accuracy. The threads of the lead screw are used for thread cutting only as the spline in the lead screw drives a worm in the apron which operates both automatic feeds. See page 7.

The Regular Equipment included with each 11-inch Quick Change Gear Lathe consists of: Double Friction Countershaft, Large Face Plate, Small Face Plate, Tool Post Complete, Adjustable Thread Cutting Stop, Two Lathe Centers and Spindle Sleeve, Center Rest, Follower Rest and Wrenches. See pages 52 and 53.

LATHE SPECIFICATIONS

Head and Tail Spindle Centers.....No. 2, Morse Taper
 Size of Spindle Nose.....1½ in. diam., 8 Threads
 Precision Acme Lead Screw.....¾ in. diam., 8 Threads
 Screw Thread Cutting Range.....2 to 112 per inch
 Width of Cone Pulley Belt.....1½ in.
 Spindle Speeds.....40, 60, 100, 230, 360, 595 R.P.M.
 Countershaft Speed.....290 R.P.M.
 Countershaft Friction Clutch Pulleys.....6½ in. x 2½ in.
 Angular Travel of Compound Rest Top.....2½ in.
 Size of Lathe Tool Shank.....¾ in. x ½ in.

Easy Payment Prices 11-inch Quick Change Gear Lathe Including Overhead Countershaft and Equipment

Catalog No. of Lathe	Swing Over Bed	Length of Bed	Between Centers	Hole Thru Spindle	Swing Over Carriage	Power Required	Weight Crated	Code Word	Price F.O.B. South Bend	Down Payment 20%	12 Equal Monthly Payments
84-Y	11¼ in.	3 ft.	12 in.	¾ in.	7½ in.	½ H.P.	675 lbs.	Eabot	\$345.00	\$69.00	\$24.15
84-Z	11¼ in.	3½ ft.	18 in.	¾ in.	7½ in.	½ H.P.	700 lbs.	Elken	352.00	70.40	24.64
84-A	11¼ in.	4 ft.	24 in.	¾ in.	7½ in.	½ H.P.	725 lbs.	Emdor	359.00	71.80	25.13
84-B	11¼ in.	5 ft.	36 in.	¾ in.	7½ in.	½ H.P.	805 lbs.	Eolin	375.00	75.00	26.25
84-S	11¼ in.	5½ ft.	42 in.	¾ in.	7½ in.	½ H.P.	845 lbs.	Epmjo	384.00	76.80	26.88

Monthly Payments include carrying charge.

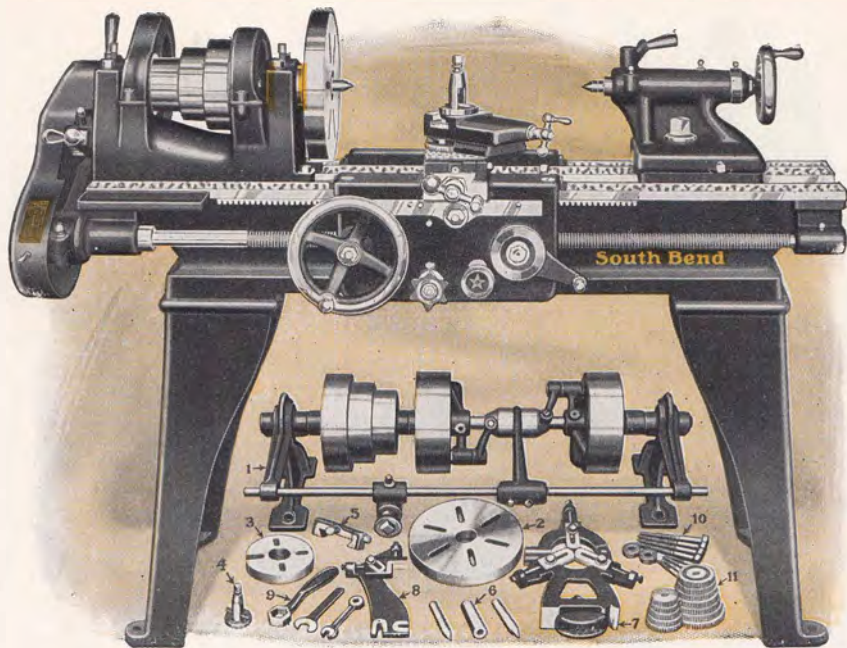

Regular equipment, as illustrated under Lathe, is included in price of Lathe

11-inch Standard Change Gear New Model South Bend Lathe

Back Geared, Screw Cutting Lathe, Countershaft Drive

The New Model 11-inch Standard Change Back Geared Screw Cutting Lathe is an excellent tool for light production work in manufacturing. It has the precision and accuracy for tool room work.

The New Headstock is back geared, reinforced and webbed, insuring strength and rigidity. Six spindle speeds are provided, three direct and three back geared. See page 6.

The Headstock Spindle is made of high carbon steel finished ground with a $\frac{7}{8}$ -inch hole its entire length. See page 8.

The Phosphor Bronze Bearings for Head Spindle are hand scraped to a perfect bearing, are adjustable for wear and are equipped with patent oilers. See page 8.

The New Model Standard Change Gear Lathe is equipped with a set of independent change gears to cut the following screw threads per inch, right or left hand, including $11\frac{1}{2}$ pipe thread: 4, 5, 6, 7, 8, 9, 10, 11, $11\frac{1}{2}$, 12, 13, 14, 16, 18, 20, 22, 24, 26, 28, 30, 32, 36 and 40. By compounding the gears furnished many other threads can be cut. See page 53.

LATHE FEATURES

Independent change gears for threads and feeds.
 Back geared headstock gives 6 spindle speeds.
 Spindle cone balanced for operating at high speeds.
 Automatic cross feed, automatic longitudinal feed.
 Hollow spindle, made of special carbon steel.
 Spring latch reverse for feeds and threads.
 Phosphor bronze bearings for spindle.
 Graduated compound rest swivels to any angle.
 Tailstock is arranged for set-over for taper turning.
 Graduated collar on cross feed and compound rest screw.
 Precision lead screw for cutting accurate threads.

The New Tailstock has a set-over for taper turning. The binding lever locks the spindle without disturbing the alignment of centers. The center is hardened. See page 6.

The New Apron has automatic cross and longitudinal feeds, and half nuts for thread cutting. An automatic safety interlock prevents the half nuts and automatic feeds from being engaged at the same time. See page 7.

The Precision Lead Screw $\frac{7}{8}$ -inch diam., 8 threads per inch Acme Standard, is cut on a special machine equipped with a master lead screw which insures accuracy. The threads of the lead screw are used for thread cutting only as the spline in the lead screw drives a worm in the apron which operates both automatic feeds. See page 7.

The Regular Equipment included with each 11-inch Standard Change Gear Lathe consists of: Double Friction Countershaft, Set of Independent Change Gears, Large and Small Face Plates, Tool Post Complete, Adjustable Thread Cutting Stop, Two Lathe Centers and Spindle Sleeve, Center Rest, Follower Rest and Wrenches. See pages 52-53.

LATHE SPECIFICATIONS

Head and Tail Spindle Centers.....No. 2, Morse Taper
 Size of Spindle Nose..... $1\frac{1}{2}$ in. diam., 8 Threads
 Precision Acme Lead Screw..... $\frac{7}{8}$ in. diam., 8 Threads
 Screw Thread Cutting Range.....4 to 40 per Inch
 Width of Gone Pulley Belt..... $1\frac{1}{2}$ in.
 Spindle Speeds.....40, 60, 100, 230, 360, 595 R.P.M.
 Countershaft Speed.....290 R.P.M.
 Countershaft Friction Clutch Pulleys..... $6\frac{1}{2}$ in. x $2\frac{1}{8}$ in.
 Angular Travel of Compound Rest Top..... $2\frac{1}{2}$ in.
 Size of Lathe Tool Shank..... $\frac{1}{2}$ in. x $\frac{7}{8}$ in.

Easy Payment Prices 11-in. Standard Change Gear Lathe Including Overhead Countershaft and Equipment

Catalog No. of Lathe	Swing Over Bed	Length of Bed	Between Centers	Hole Thru Spindle	Swing Over Carriage	Power Required	Weight Crated	Code Word	Price F. O. B. South Bend	Down Payment 20%	12 Equal Monthly Payments
33-Y	$11\frac{1}{4}$ in.	3 ft.	12 in.	$\frac{7}{8}$ in.	$7\frac{1}{2}$ in.	$\frac{1}{2}$ H.P.	600 lbs.	Eazlr	\$295.00	\$59.00	\$20.65
33-Z	$11\frac{1}{4}$ in.	$3\frac{1}{2}$ ft.	13 in.	$\frac{7}{8}$ in.	$7\frac{1}{2}$ in.	$\frac{1}{2}$ H.P.	685 lbs.	Ebuka	302.00	60.40	21.14
33-A	$11\frac{1}{4}$ in.	4 ft.	$14\frac{1}{2}$ in.	$\frac{7}{8}$ in.	$7\frac{1}{2}$ in.	$\frac{1}{2}$ H.P.	710 lbs.	Eesty	309.00	61.80	21.63
33-B	$11\frac{1}{4}$ in.	5 ft.	36 in.	$\frac{7}{8}$ in.	$7\frac{1}{2}$ in.	$\frac{1}{2}$ H.P.	790 lbs.	Edres	325.00	65.00	22.75
33-S	$11\frac{1}{4}$ in.	$5\frac{1}{2}$ ft.	42 in.	$\frac{7}{8}$ in.	$7\frac{1}{2}$ in.	$\frac{1}{2}$ H.P.	830 lbs.	Efmot	334.00	66.80	23.38

Monthly Payments include carrying charge.

SOUTH BEND, INDIANA, U. S. A.

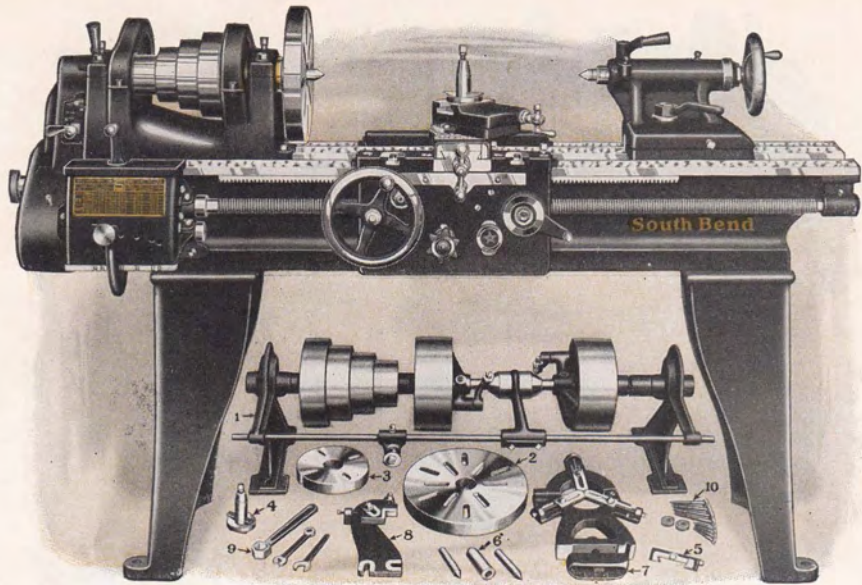

Regular equipment, as illustrated under Lathe, is included in price of Lathe

13-inch Quick Change Gear New Model South Bend Lathe

Back Geared, Screw Cutting Lathe, Countershaft Drive

The New Model 13-inch Quick Change Back Geared Screw Cutting Lathe is an ideal tool for the factory on production work. It has the precision and accuracy for fine tool room work.

The New Headstock is back geared, reinforced and webbed, insuring strength and rigidity. Eight spindle speeds are provided, four direct and four back geared. See page 6.

The Headstock Spindle is made of high carbon steel finished ground with a 1-inch hole its entire length. See page 8.

The Phosphor Bronze Bearings for Head Spindle are hand scraped to a perfect bearing, are adjustable for wear and are equipped with oilers. See page 8.

The Quick Change Gear Box provides 48 changes for cutting right or left-hand screw threads from 2 to 112 per inch without removing a gear. An index plate shows the arrangement for cutting the following threads: 2, 2¼, 2½, 2¾, 2⅞, 3, 3¼, 3½, 4, 4½, 5, 5½, 5¾, 6, 6½, 7, 8, 9, 10, 11, 11½, 12, 13, 14, 16, 18, 20, 22, 23, 24, 26, 28, 32, 36, 40, 44, 46, 48, 52, 56, 64, 72, 80, 88, 92, 96, 104, 112. See page 5.

LATHE FEATURES

Full quick change gear mechanism.
 Back Geared headstock gives 8 spindle speeds.
 Automatic cross feed, automatic longitudinal feed.
 Hollow spindle made of special carbon steel.
 Spring latch reverse for feeds and threads.
 Phosphor bronze bearings for spindle.
 Graduated compound rest swivels to any angle.
 Tailstock is arranged for set-over for taper turning.
 Graduated collar on cross feed and compound rest screws.
 Precision lead screw for cutting accurate threads.

The New Tailstock has a set-over for taper turning. The binding lever locks the spindle without disturbing the alignment of centers. The center is hardened. See page 6.

The New Apron has automatic cross and longitudinal feeds, and half nuts for thread cutting. An automatic safety interlock prevents the half nuts and automatic feeds from being engaged at the same time. See page 7.

The Precision Lead Screw 1-inch diam., 6 threads per inch, Acme Standard, is cut on a special machine equipped with a master lead screw which insures accuracy. The threads of the lead screw are used for thread cutting only as the spline in the lead screw drives a worm in the apron which operates both automatic feeds. See page 7.

The Regular Equipment included with each 13-inch Quick Change Gear Lathe consists of: Double Friction Countershaft, Large Face Plate, Small Face Plate, Tool Post Complete, Adjustable Thread Cutting Stop, Two Lathe Centers and Spindle Sleeve, Center Rest, Follower Rest and Wrenches. See pages 52 and 53.

LATHE SPECIFICATIONS

Head and Tail Spindle Centers.....No. 3 Morse Taper
 Size of Spindle Nose.....1 7/8 in. diam., 8 Threads
 Precision Acme Lead Screw.....1 in. diam., 6 Threads
 Screw Thread Cutting Range.....2 to 112 per inch
 Width of Cone Pulley Belt.....1 1/4 in.
 Spindle Speeds...25, 40, 60, 100, 180, 275, 425, 685 R.P.M.
 Countershaft Speed.....275 R.P.M.
 Countershaft Friction Clutch Pulleys.....8 in. x 2 1/2 in.
 Angular Travel of Compound Rest Top.....3 in.
 Size of Lathe Tool Shank.....1/2 in. x 1 1/4 in.

Easy Payment Prices 13-inch Quick Change Gear Lathe Including Overhead Countershaft and Equipment

Catalog No. of Lathe	Swing Over Bed	Length of Bed	Between Centers	Hole Thru Spindle	Swing Over Carriage	Power Required	Weight Crated	Code Word	Price F.O.B. South Bend	Down Payment 20%	12 Equal Monthly Payments
86-A	13 1/4 in.	4 ft.	16 in.	1 in.	9 in.	3/4 H.P.	1060 lbs.	Galup	\$428.00	\$85.60	\$29.96
86-B	13 1/4 in.	5 ft.	28 in.	1 in.	9 in.	3/4 H.P.	1110 lbs.	Gehos	443.00	88.60	31.01
86-C	13 1/4 in.	6 ft.	40 in.	1 in.	9 in.	3/4 H.P.	1160 lbs.	Gifts	458.00	91.60	32.06
86-D	13 1/4 in.	7 ft.	52 in.	1 in.	9 in.	3/4 H.P.	1210 lbs.	Gobli	475.00	95.00	33.25
86-E	13 1/4 in.	8 ft.	64 in.	1 in.	9 in.	3/4 H.P.	1260 lbs.	Guaik	494.00	98.80	34.58

If Bench Legs are wanted instead of Floor Legs deduct \$10.00.
 Monthly Payments include carrying charge.

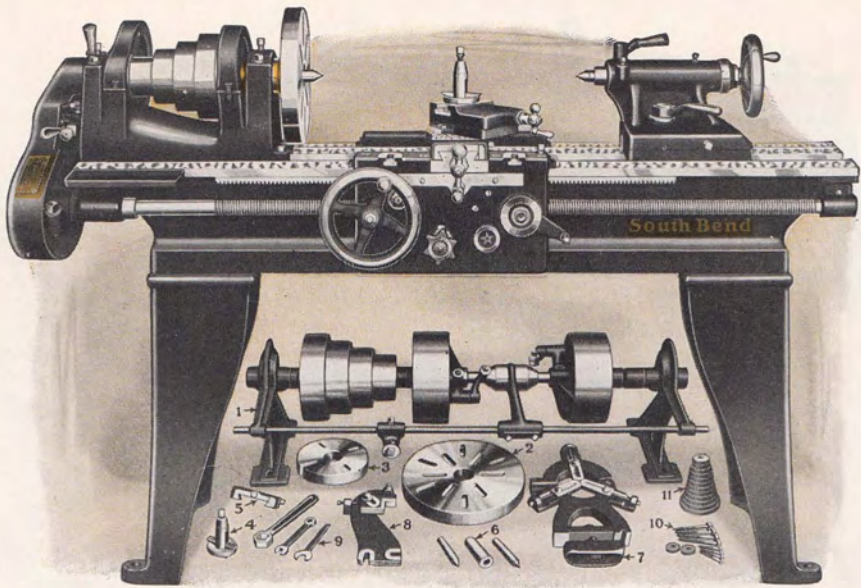

Regular equipment, as illustrated under Lathe, is included in price of Lathe

13-inch Standard Change Gear New Model South Bend Lathe

Back Geared, Screw Cutting Lathe, Countershaft Drive

The New Model 13-inch Standard Change Back Geared Screw Cutting Lathe is an ideal tool for the factory on production work. It has the precision and accuracy for fine tool room work.

The New Headstock is back geared, reinforced and webbed, insuring strength and rigidity. Eight spindle speeds are provided, four direct and four back geared. See page 6.

The Headstock Spindle is made of high carbon steel finished ground with a 1-inch hole its entire length. See page 8.

The Phosphor Bronze Bearings for Head Spindle are hand scraped to a perfect bearing, are adjustable for wear and are equipped with oilers. See page 8.

The New Model Standard Change Gear Lathe is equipped with a set of independent change gears to cut the following screw threads per inch, right or left hand, including 1 1/2 pipe thread: 2, 3, 4, 5, 6, 7, 8, 9, 10, 11, 11 1/2, 12, 13, 14, 16, 18, 20, 22, 24, 26, 28, 30, 32, 36 and 40. By compounding the gears furnished many other threads can be cut. See page 53.

LATHE FEATURES

- Independent change gears for threads and feeds.
- Back geared headstock gives 8 spindle feeds.
- Automatic cross feed, automatic longitudinal feed.
- Hollow spindle, made of special carbon steel.
- Spring latch reverse for feeds and threads.
- Phosphor bronze bearings for spindle.
- Graduated compound rest swivels to any angle.
- Tailstock is arranged for set-over for taper turning.
- Graduated collar on cross feed and compound rest screw.
- Precision lead screw for cutting accurate threads.

The New Tailstock has a set-over for taper turning. The binding lever locks the spindle without disturbing the alignment of centers. The center is hardened. See page 6.

The New Apron has automatic cross and longitudinal feeds, and half nuts for thread cutting. An automatic safety interlock prevents the half nuts and automatic feeds from being engaged at the same time. See page 7.

The Precision Lead Screw 1-inch diam., 6 threads per inch, Acme Standard, is cut on a special machine equipped with a master lead screw which insures accuracy. The threads of the lead screw are used for thread cutting only as the spline in the lead screw drives a worm in the apron which operates both automatic feeds. See page 7.

The Regular Equipment included with each 13-inch Standard Change Gear Lathe consists of: Double Friction Countershaft, Set of Independent Change Gears, Large and Small Face Plates, Tool Post Complete, Adjustable Thread Cutting Stop, Two Lathe Centers and Spindle Sleeve, Center Rest, Follower Rest and Wrenches. Pages 52 and 53.

LATHE SPECIFICATIONS

- Head and Tail Spindle Centers.....No. 3, Morse Taper
- Size of Spindle Nose.....1 7/8 in. diam., 8 Threads
- Precision Acme Lead Screw.....1 in. diam., 6 Threads
- Screw Thread Cutting Range.....2 to 40 per inch
- Width of Cone Pulley Belt.....1 3/4 in.
- Spindle Speeds.....25, 40, 60, 100, 180, 275, 425, 685 R.P.M.
- Countershaft Speed.....275 R.P.M.
- Countershaft Friction Clutch Pulleys.....8 in. x 2 3/8 in.
- Angular Travel of Compound Rest Top.....3 in.
- Size of Lathe Tool Shank.....1/2 in. x 1 1/8 in.

Easy Payment Prices 13-in. Standard Change Gear Lathe Including Overhead Countershaft and Equipment

Catalog No. of Lathe	Swing Over Bed	Length of Bed	Between Centers	Hole Thru Spindle	Swing Over Carriage	Power Required	Weight Crated	Code Word	Price F.O.B. South Bend	Down Payment 20%	12 Equal Monthly Payments
35-A	13 3/4 in.	4 ft.	16 in.	1 in.	9 in.	3/4 H.P.	1040 lbs.	Gaget	\$368.00	\$73.60	\$25.76
35-B	13 3/4 in.	5 ft.	28 in.	1 in.	9 in.	3/4 H.P.	1090 lbs.	Geldy	383.00	76.60	26.81
35-C	13 3/4 in.	6 ft.	40 in.	1 in.	9 in.	3/4 H.P.	1140 lbs.	Gisot	398.00	79.60	27.86
35-D	13 3/4 in.	7 ft.	52 in.	1 in.	9 in.	3/4 H.P.	1190 lbs.	Goldy	415.00	83.00	29.03
35-E	13 3/4 in.	8 ft.	64 in.	1 in.	9 in.	3/4 H.P.	1240 lbs.	Guset	434.00	86.80	30.38

If Bench Legs are wanted instead of Floor Legs deduct \$10.00.

Monthly Payments include carrying charge.

SOUTH BEND, INDIANA, U. S. A.

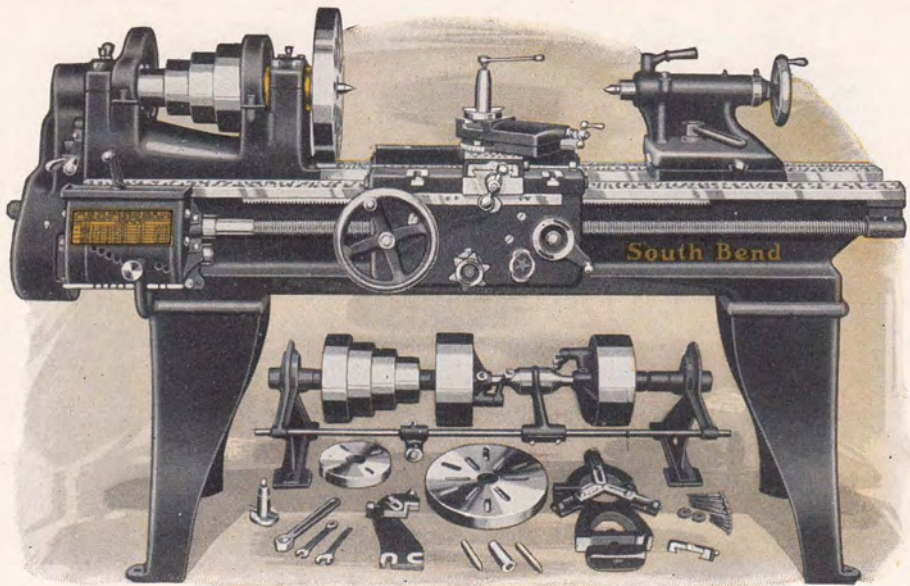

Regular equipment, as illustrated under Lathe, is included in price of Lathe

15-inch Quick Change Gear New Model South Bend Lathe

Back Geared, Screw Cutting Lathe, Countershaft Drive

The New Model 15-inch Quick Change Back Geared Screw Cutting Lathe has the power for production work in manufacturing, the precision and accuracy for fine tool work.

The New Headstock is back geared, reinforced and webbed, insuring strength and rigidity. Eight spindle speeds are provided, four direct and four back geared. See page 6.

The Headstock Spindle is made of high carbon steel finished ground with a 1 1/8-inch hole its entire length. See page 8.

The Phosphor Bronze Bearings for Head Spindle are hand scraped to a perfect bearing, are adjustable for wear and are equipped with oilers. See page 8.

The Quick Change Gear Box provides 48 changes for cutting right or left hand screw threads from 2 to 112 per inch without removing a gear. An index plate shows the arrangement for cutting the following threads: 2, 2 1/4, 2 1/2, 2 3/4, 2 7/8, 3, 3 1/4, 3 1/2, 4, 4 1/2, 5, 5 1/2, 5 3/4, 6, 6 1/2, 7, 8, 9, 10, 11, 11 1/2, 12, 13, 14, 16, 18, 20, 22, 23, 24, 26, 28, 32, 36, 40, 44, 46, 48, 52, 56, 64, 72, 80, 88, 92, 96, 104, 112. See page 5.

LATHE FEATURES

Full quick change gear mechanism.
Back geared headstock gives 8 spindle speeds.
Automatic cross feed, automatic longitudinal feed.
Hollow spindle made of special carbon steel.
Spring latch reverse for feeds and threads.
Phosphor bronze bearings for spindle.
Graduated compound rest swivels to any angle.
Tailstock is arranged for set-over for taper turning.
Graduated collar on cross feed and compound rest screw.
Precision lead screw for cutting accurate threads.

The New Tailstock has a set-over for taper turning. The binding lever locks the spindle without disturbing the alignment of centers. The center is hardened. See page 6.

The New Apron has automatic cross and longitudinal feeds, and half nuts for thread cutting. An automatic safety interlock prevents the half nuts and automatic feeds from being engaged at the same time. See page 7.

The Precision Lead Screw 1 1/8-inch diam., 6 threads per inch Acme Standard, is cut on a special machine equipped with a master lead screw which insures accuracy. The threads of the lead screw are used for thread cutting only as the spline in the lead screw drives a worm in the apron which operates both automatic feeds. See page 7.

The Regular Equipment included with each 15-inch Quick Change Gear Lathe consists of: Double Friction Countershaft, Large and Small Face Plates, Tool Post Complete, Thread Cutting Stop, Two Lathe Centers and Spindle Sleeve, Center Rest, Follower Rest and Wrenches. See pages 52 and 53.

LATHE SPECIFICATIONS

Head and Tail Spindle Centers.....No. 3, Morse Taper
Size of Spindle Nose.....2 1/2 in. diam., 6 Threads
Precision Acme Lead Screw.....1 1/8 in. diam., 6 Threads
Screw Thread Cutting Range.....2 to 112 per inch
Width of Cone Pulley Belt.....2 in.
Spindle Speeds.....22, 36, 58, 95, 160, 250, 395, 660 R.P.M.
Countershaft Speed.....250 R.P.M.
Countershaft Friction Clutch Pulleys.....10 in. x 3 3/8 in.
Angular Travel of Compound Rest Top.....3 3/8 in.
Size of Lathe Tool Shank.....1/2 in. x 1 1/8 in.

Easy Payment Prices 15-inch Quick Change Gear Lathe Including Overhead Countershaft and Equipment

No. of Lathe	Swing Over Bed	Length of Bed	Between Centers	Hole Thru Spindle	Swing Over Carriage	Power Required	Weight Crated	Co#e Word	Price F. O. B. South Bend	Down Payment 20%	12 Equal Monthly Payments
88-B	15 1/2 in.	5 ft.	24 1/2 in.	1 1/8 in.	10 1/2 in.	1 H.P.	1475 lbs.	Latin	\$525.00	\$105.00	\$36.75
88-C	15 1/2 in.	6 ft.	30 1/2 in.	1 1/8 in.	10 1/2 in.	1 H.P.	1550 lbs.	Lemon	543.00	108.60	38.01
88-D	15 1/2 in.	7 ft.	48 1/2 in.	1 1/8 in.	10 1/2 in.	1 H.P.	1625 lbs.	Liquor	561.00	112.20	39.27
88-E	15 1/2 in.	8 ft.	60 1/2 in.	1 1/8 in.	10 1/2 in.	1 H.P.	1735 lbs.	Lower	581.00	116.20	40.67
88-G	15 1/2 in.	10 ft.	81 1/2 in.	1 1/8 in.	10 1/2 in.	1 H.P.	1900 lbs.	Lupin	625.00	125.00	43.75

Monthly Payments include carrying charge.

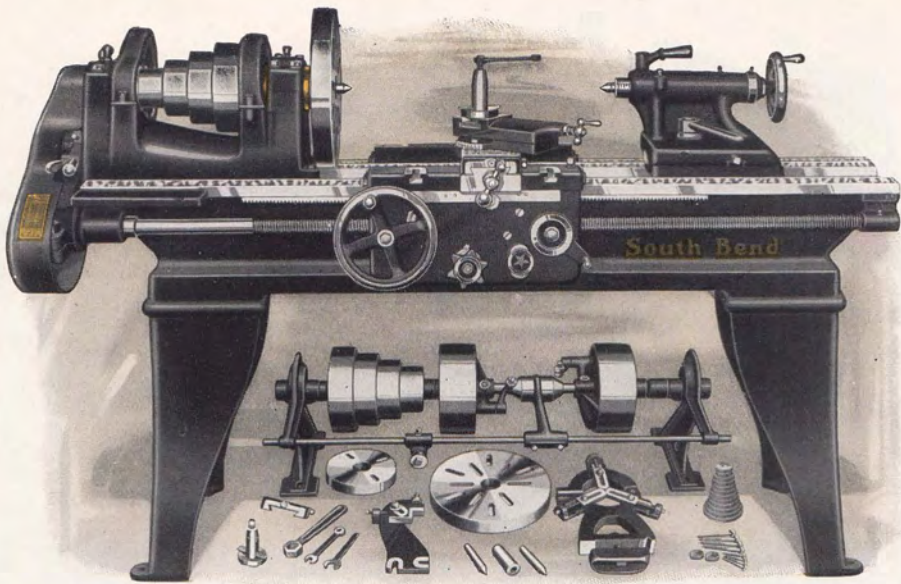

Regular equipment, as illustrated under Lathe, is included in price of Lathe

15-inch Standard Change Gear New Model South Bend Lathe

Back Geared, Screw Cutting Lathe, Countershaft Drive

The New Model 15-inch Standard Change Gear Geared Screw Cutting Lathe has the power for production work in manufacturing; the precision and accuracy for fine tool work, and the capacity for general machine work.

The New Headstock is back geared, reinforced and webbed, insuring strength and rigidity. Eight spindle speeds are provided, four direct and four back geared. See page 6.

The Headstock Spindle is made of high carbon steel finished ground with a 1 1/8-inch hole its entire length. See page 8.

The Phosphor Bronze Bearings for Head Spindle are hand scraped to a perfect bearing, are adjustable for wear and are equipped with oilers. See page 8.

The New Model Standard Change Gear Lathe is equipped with a set of independent change gears to cut the following screw threads per inch, right or left-hand, including 1 1/2 pipe thread: 2, 3, 4, 5, 6, 7, 8, 9, 10, 11, 11 1/2, 12, 13, 14, 16, 18, 20, 22, 24, 26, 28, 30, 32, 36 and 40. By compounding the gears furnished many other threads can be cut. See page 53.

LATHE FEATURES

Independent change gears for threads and feeds.
 Back geared headstock gives 8 spindle speeds.
 Automatic cross feed, automatic longitudinal feed.
 Hollow spindle, made of special carbon steel.
 Spring latch reverse for feeds and threads.
 Phosphor bronze bearings for spindle.
 Graduated compound rest swivels to any angle.
 Tailstock is arranged for set-over for taper turning.
 Graduated collar on cross feed and compound rest screw.
 Precision lead screw for cutting accurate threads.

The New Tailstock has a set-over for taper turning. The binding lever locks the spindle without disturbing the alignment of centers. The center is hardened. See page 6.

The New Apron has automatic cross and longitudinal feeds, and half nuts for thread cutting. An automatic safety interlock prevents the half nuts and automatic feeds from being engaged at the same time. See page 7.

The Precision Lead Screw 1 1/8-inch diam., 6 threads per inch Acme Standard, is cut on a special machine equipped with a master lead screw which insures accuracy. The threads of the lead screw are used for thread cutting only as the spline in the lead screw drives a worm in the apron which operates both automatic feeds. See page 7.

The Regular Equipment included with each 15-inch Standard Change Gear Lathe consists of: Double Friction Countershaft, Set of Independent Change Gears, Large and Small Face Plates, Tool Post Complete, Adjustable Thread Cutting Stop, Two Lathe Centers and Spindle Sleeve, Center Rest, Follower Rest and Wrenches. See pages 52 and 53.

LATHE SPECIFICATIONS

Head and Tail Spindle Centers.....No. 3, Morse Taper
 Size of Spindle Nose.....2 1/4 in. diam., 6 Threads
 Precision Acme Lead Screw.....1 1/8 in. diam., 6 Threads
 Screw Thread Cutting Range.....2 to 40 per inch
 Width of Cone Pulley Belt.....2 in.
 Spindle Speeds.....22, 36, 58, 95, 160, 250, 395, 660 R.P.M.
 Countershaft Speed.....250 R.P.M.
 Countershaft Friction Clutch Pulleys.....10 in. x 3/8 in.
 Angular Travel of Compound Rest Top.....3 1/2 in.
 Size of Lathe Tool Shank.....1/2 in. x 1 1/8 in.

Easy Payment Prices 15-in. Standard Change Gear Lathe Including Overhead Countershaft and Equipment

No. of Lathe	Swing Over Bed	Length of Bed	Between Centers	Hole Thru Spindle	Swing Over Carriage	Power Required	Weight Crated	Code Word	Price F.O.B. South Bend	Down Payment 20%	12 Equal Monthly Payments
39-B	15 1/4 in.	5 ft.	24 1/2 in.	1 1/4 in.	10% in.	1 H.P.	1450 lbs.	Lance	\$450.00	\$ 90.00	\$31.50
39-C	15 1/4 in.	6 ft.	36 1/2 in.	1 1/4 in.	10% in.	1 H.P.	1525 lbs.	Lewis	468.00	93.60	32.76
39-D	15 1/4 in.	7 ft.	48 1/2 in.	1 1/4 in.	10% in.	1 H.P.	1600 lbs.	Liver	486.00	97.20	34.02
39-E	15 1/4 in.	8 ft.	60 1/2 in.	1 1/4 in.	10% in.	1 H.P.	1710 lbs.	Lovit	506.00	101.20	35.42
39-G	15 1/4 in.	10 ft.	84 1/2 in.	1 1/4 in.	10% in.	1 H.P.	1875 lbs.	Lunar	550.00	110.00	38.50

Monthly Payments include carrying charge.

SOUTH BEND, INDIANA, U. S. A.

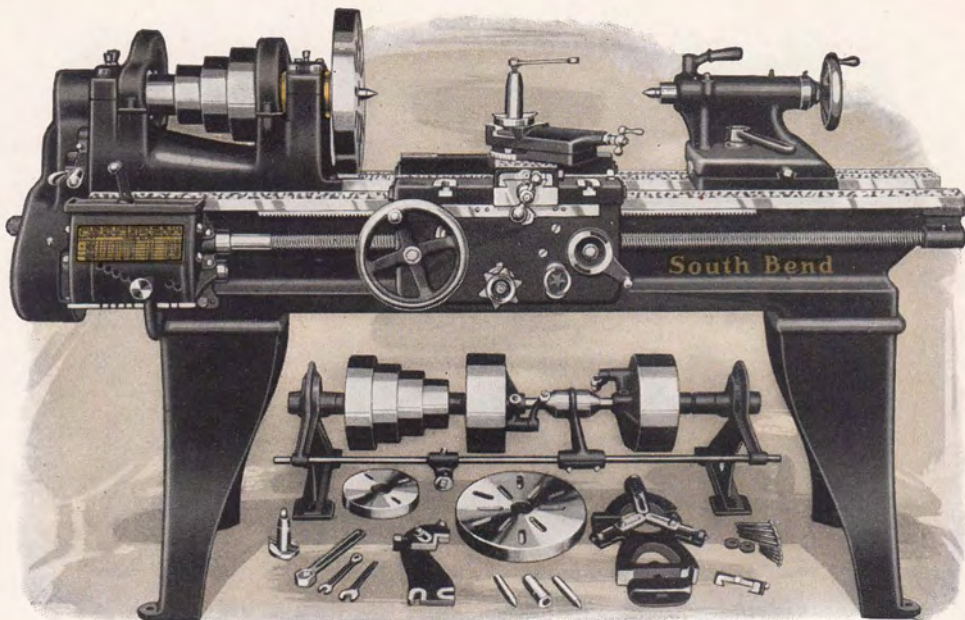

Regular equipment, as illustrated under Lathe, is included in price of Lathe

16-inch Quick Change Gear New Model South Bend Lathe

Back Geared, Screw Cutting Lathe, Countershaft Drive

The New Model 16-inch Quick Change Back Geared Screw Cutting Lathe has the power for heavy production work in manufacturing, the precision and accuracy for fine tool work and for a variety of general work.

The New Headstock is back geared, reinforced and webbed, insuring strength and rigidity. Eight spindle speeds are provided, four direct and four back geared. See page 6.

The Headstock Spindle is made of high carbon steel finished ground with a 1 1/8-inch hole its entire length. See page 8.

The Phosphor Bronze Bearings for Head Spindle are hand scraped to a perfect bearing, are adjustable for wear and are equipped with oilers. See page 8.

The Quick Change Gear Box provides 48 changes for cutting right or left hand screw threads from 2 to 112 per inch without removing a gear. An index plate shows the arrangement for cutting the following threads: 2, 2 1/4, 2 1/2, 2 3/4, 2 7/8, 3, 3 1/4, 3 1/2, 4, 4 1/2, 5, 5 1/2, 5 3/4, 6, 6 1/2, 7, 8, 9, 10, 11, 11 1/2, 12, 13, 14, 16, 18, 20, 22, 23, 24, 26, 28, 32, 36, 40, 44, 46, 48, 52, 56, 64, 72, 80, 88, 92, 96, 104, 112. See page 5.

LATHE FEATURES

Full quick change gear mechanism.
Back geared headstock gives 8 spindle speeds.
Automatic cross feed, automatic longitudinal feed.
Hollow spindle made of special carbon steel.
Spring latch reverse for feeds and threads.
Phosphor bronze bearings for spindle.
Graduated compound rest swivels to any angle.
Tailstock is arranged for set-over for taper turning.
Graduated collar on cross feed and compound rest screws.
Precision lead screw for cutting accurate threads.

Easy Payment Prices 16-inch Quick Change Gear Lathe Including Overhead Countershaft and Equipment

No. of Lathe	Swing Over Bed	Length of Bed	Between Centers	Hole Thru Spindle	Swing Over Carriage	Power Required	Weight Crated	Code Word	Price F. O. B. South Bend	Down Payment 20%	12 Equal Monthly Payments
92-C	16 1/4 in.	6 ft.	34 in.	1 3/8 in.	11 1/2 in.	1 H.P.	1875 lbs.	Malta	\$598.00	\$119.60	\$41.86
92-D	16 1/4 in.	7 ft.	46 in.	1 3/8 in.	11 1/2 in.	1 H.P.	1955 lbs.	Melbo	618.00	123.60	43.26
92-E	16 1/4 in.	8 ft.	58 in.	1 3/8 in.	11 1/2 in.	1 H.P.	2035 lbs.	Mitre	638.00	127.60	44.66
92-G	16 1/4 in.	10 ft.	82 in.	1 3/8 in.	11 1/2 in.	1 H.P.	2195 lbs.	Movir	682.00	136.40	47.74
*92-H	16 1/4 in.	12 ft.	106 in.	1 3/8 in.	11 1/2 in.	1 H.P.	2355 lbs.	Muday	745.00	149.00	52.15

Monthly Payments include carrying charge.

*Lathe with 12-foot bed is equipped with center leg.

The New Tailstock has a set-over for taper turning. The binding lever locks the spindle without disturbing the alignment of centers. The center is hardened. See page 6.

The New Apron has automatic cross and longitudinal feeds, and half nuts for thread cutting. An automatic safety interlock prevents the half nuts and automatic feeds from being engaged at the same time. See page 7.

The Precision Lead Screw 1 1/8-inch diam., 6 threads per inch Acme Standard, is cut on a special machine equipped with a master lead screw which insures accuracy. The threads of the lead screw are used for thread cutting only as the spline in the lead screw drives a worm in the apron which operates both automatic feeds. See page 7.

The Regular Equipment included with each 16-inch Quick Change Gear Lathe consists of: Double Friction Countershaft, Large Face Plate, Small Face Plate, Tool Post Complete, Adjustable Thread Cutting Stop, Two Lathe Centers and Spindle Sleeve, Center Rest, Follower Rest and Wrenches. See pages 52 and 53.

LATHE SPECIFICATIONS

Head and Tail Spindle Centers.....No. 3, Morse Taper
Size of Spindle Nose.....2 1/2 in. diam., 6 Threads
Precision Acme Lead Screw.....1 1/8 in. diam., 6 Threads
Screw Thread Cutting Range.....2 to 112 per inch
Width of Cone Pulley Belt.....2 1/4 in.
Spindle Speeds...20, 30, 50, 75, 140, 225, 360, 610 R.P.M.
Countershaft Speed.....225 R.P.M.
Countershaft Friction Clutch Pulleys.....10 in. x 3 3/8 in.
Angular Travel of Compound Rest Top.....3 3/4 in.
Size of Lathe Tool Shank.....1/2 in. x 1 1/8 in.

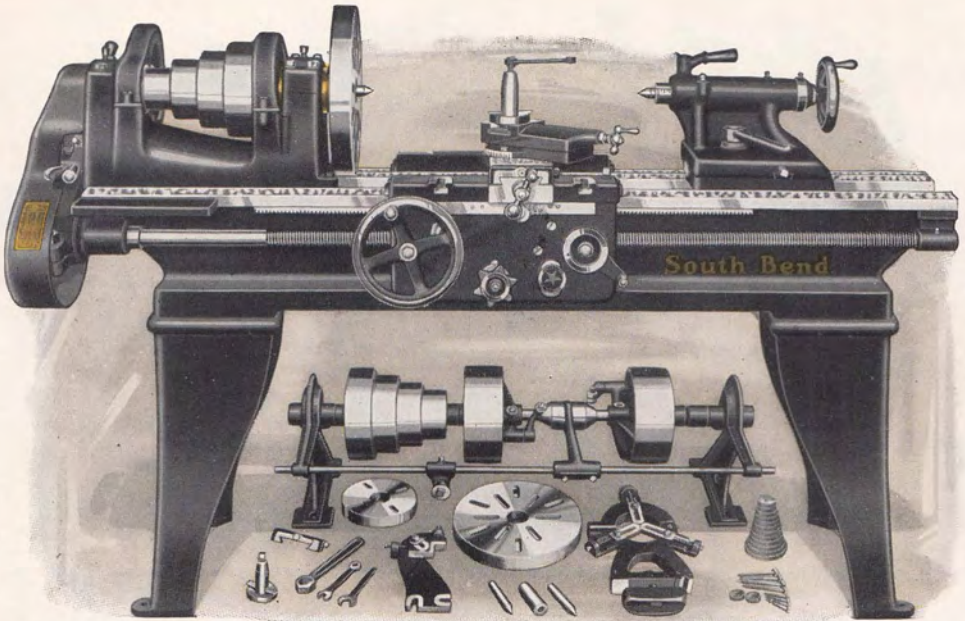

Regular equipment, as illustrated under Lathe, is included in price of Lathe

16-inch Standard Change Gear New Model South Bend Lathe

Back Geared, Screw Cutting Lathe, Countershaft Drive

The New Model 16-inch Standard Change Gear Geared Screw Cutting Lathe has the power for heavy production work in manufacturing, the precision and accuracy for fine tool room work, and for a variety of general work.

The New Headstock is back geared, reinforced and webbed, insuring strength and rigidity. Eight spindle speeds are provided, four direct and four back geared. See page 6.

The Headstock Spindle is made of high carbon steel finished ground with a 1 7/8-inch hole its entire length. See page 8.

The Phosphor Bronze Bearings for Head Spindle are hand scraped to a perfect bearing, are adjustable for wear and are equipped with oilers. See page 8.

The New Model Standard Change Gear Lathe is equipped with a set of independent change gears to cut the following screw threads per inch, right or left-hand, including 1 1/2 pipe thread: 2, 3, 4, 5, 6, 7, 8, 9, 10, 11, 11 1/2, 12, 13, 14, 16, 18, 20, 22, 24, 26, 28, 30, 32, 36 and 40. By compounding the gears furnished many other threads can be cut. See page 53.

The New Tailstock has a set-over for taper turning. The binding lever locks the spindle without disturbing the alignment of centers. The center is hardened. See page 6.

The New Apron has automatic cross and longitudinal feeds, and half nuts for thread cutting. An automatic safety interlock prevents the half nuts and automatic feeds from being engaged at the same time. See page 7.

The Precision Lead Screw 1 1/8-inch diam., 6 threads per inch Acme Standard, is cut on a special machine equipped with a master lead screw which insures accuracy. The threads of the lead screw are used for thread cutting only as the spline in the lead screw drives a worm in the apron which operates both automatic feeds. See page 7.

The Regular Equipment included with each 16-inch Standard Change Gear Lathe consists of: Double Friction Countershaft, Set of Independent Change Gears, Large and Small Face Plates, Tool Post Complete, Adjustable Thread Cutting Stop, Two Lathe Centers and Spindle Sleeve, Center Rest, Follower Rest and Wrenches. See pages 52 and 53.

LATHE FEATURES

Independent change gears for threads and feeds.
 Back geared headstock gives 8 spindle speeds.
 Automatic cross feed, automatic longitudinal feed.
 Hollow spindle, made of special carbon steel.
 Spring latch reverse for feeds and threads.
 Phosphor bronze bearings for spindle.
 Graduated compound rest swivels to any angle.
 Tailstock is arranged for set-over for taper turning.
 Graduated collar on cross feed and compound rest screw.
 Precision lead screw for cutting accurate threads.

LATHE SPECIFICATIONS

Head and Tall Spindle Centers.....No. 3, Morse Taper
 Size of Spindle Nose.....2 1/2 in. diam., 6 Threads
 Precision Acme Lead Screw.....1 1/8 in. diam., 6 Threads
 Screw Thread Cutting Range......2 to 40 per inch
 Width of Cone Pulley Belts..........2 1/4 in.
 Spindle Speeds.....20, 30, 50, 75, 140, 225, 360, 610 R.P.M.
 Countershaft Speed..........225 R.P.M.
 Countershaft Friction Clutch Pulleys.....10 in. x 3 1/2 in.
 Angular Travel of Compound Rest Top.....3 1/4 in.
 Size of Lathe Tool Shank..........1/2 in. x 1 1/2 in.

Easy Payment Prices 16-in. Standard Change Gear Lathe Including Overhead Countershaft and Equipment

No. of Lathe	Swing Over Bed	Length of Bed	Between Centers	Hole Thru Spindle	Swing Over Carriage	Power Required	Weight Crated	Code Word	Price F.O.B. South Bend	Down Payment 20%	12 Equal Monthly Payments
41-C	16 1/2 in.	6 ft.	34 in.	1 3/8 in.	11 1/2 in.	1 H.P.	1840 lbs.	Mater	\$518.00	\$103.60	\$36.26
41-D	16 1/2 in.	7 ft.	46 in.	1 3/8 in.	11 1/2 in.	1 H.P.	1920 lbs.	Medow	538.00	107.60	37.66
41-E	16 1/2 in.	8 ft.	58 in.	1 3/8 in.	11 1/2 in.	1 H.P.	2000 lbs.	Milky	558.00	111.60	39.66
41-G	16 1/2 in.	10 ft.	82 in.	1 3/8 in.	11 1/2 in.	1 H.P.	2160 lbs.	Money	602.00	120.40	42.14
*41-H	16 1/2 in.	12 ft.	106 in.	1 3/8 in.	11 1/2 in.	1 H.P.	2320 lbs.	Mules	665.00	133.00	46.55

Monthly Payments include carrying charge.

*Lathe with 12-foot bed is equipped with center leg.

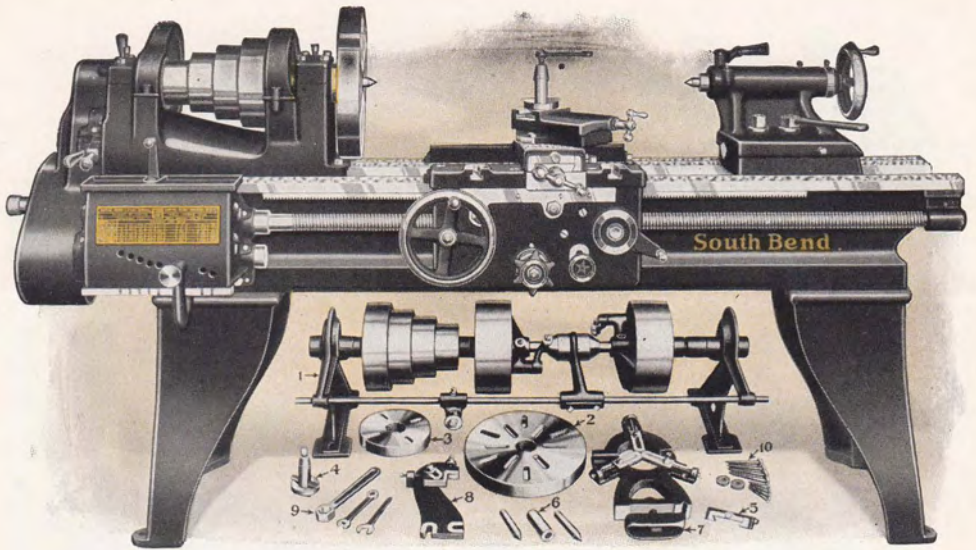

Regular equipment, as illustrated under Lathe, is included in price of Lathe

18-inch Quick Change Gear New Model South Bend Lathe

Back Geared, Screw Cutting Lathe, Countershaft Drive

The New Model 18-inch Quick Change Back Geared Screw Cutting Lathe has the power for heavy production work, manufacturing, and precision and accuracy for fine tool room work. It is an excellent tool for all kinds of work in the machine shop.

The New Headstock is back geared, reinforced and webbed, insuring strength and rigidity. Eight spindle speeds are provided, four direct and four back geared. See page 6.

The Headstock Spindle is made of high carbon steel finished ground with a 1 1/8-inch hole its entire length. See page 8.

The Phosphor Bronze Bearings for Head Spindle are hand scraped to a perfect bearing, are adjustable for wear and are equipped with oilers. See page 8.

The Quick Change Gear Box provides 48 changes for cutting right or left-hand screw threads from 2 to 112 per inch without removing a gear. An index plate shows the arrangement for cutting the following threads: 2, 2 1/4, 2 1/2, 2 3/4, 2 7/8, 3, 3 1/4, 3 1/2, 4, 4 1/2, 5, 5 1/2, 5 3/4, 6, 6 1/2, 7, 8, 9, 10, 11, 11 1/2, 12, 13, 14, 16, 18, 20, 22, 23, 24, 26, 28, 32, 36, 40, 44, 46, 48, 52, 56, 64, 72, 80, 88, 92, 96, 104, 112. See page 5.

LATHE FEATURES

Full quick change gear mechanism.
Back geared headstock gives 8 spindle speeds.
Automatic cross feed, automatic longitudinal feed.
Hollow spindle made of special carbon steel.
Spring latch reverse for feeds and threads.
Phosphor bronze bearings for spindle.
Graduated compound rest swivels to any angle.
Tailstock is arranged for set-over for taper turning.
Graduated collar on cross feed and compound rest screws.
Precision lead screw for cutting accurate threads.

The New Tailstock has a set-over for taper turning. The binding lever locks the spindle without disturbing the alignment of centers. The center is hardened. See page 6.

The New Apron has automatic cross and longitudinal feeds, and half nuts for thread cutting. An automatic safety interlock prevents the half nuts and automatic feeds from being engaged at the same time. See page 7.

The Precision Lead Screw 1 1/8-inch diam., 4 threads per inch Acme Standard, is cut on a special machine equipped with a master lead screw which insures accuracy. The threads of the lead screw are used for thread cutting only as the spline in the lead screw drives a worm in the apron which operates both automatic feeds. See page 7.

The Regular Equipment included with each 18-inch Quick Change Gear Lathe consists of: Double Friction Countershaft, Large Face Plate, Small Face Plate, Tool Post Complete, Adjustable Thread Cutting Stop, Two Lathe Centers and Spindle Sleeve, Center Rest, Follower Rest and Wrenches. See pages 52 and 53.

LATHE SPECIFICATIONS

Head and Tall Spindle Centers.....No. 3, Morse Taper
Size of Spindle Nose.....2 1/2 in. diam., 6 Threads
Precision Acme Lead Screw.....1 1/8 in. diam., 4 Threads
Screw Thread Cutting Range.....2 to 112 per inch
Width of Cone Pulley Belt.....2 1/2 in.
Spindle Speeds.....18, 23, 45, 70, 135, 200, 300, 465 R.P.M.
Countershaft Speed.....200 R.P.M.
Countershaft Friction Clutch Pulleys.....12 in. x 4 1/2 in.
Angular Travel of Compound Rest Top.....4 1/2 in.
Size of Lathe Tool Shank.....1/2 in. x 1 1/8 in.

Easy Payment Prices 18-inch Quick Change Gear Lathe Including Overhead Countershaft and Equipment

No. of Lathe	Swing Over Bed	Length of Bed	Between Centers	Hole Thru Spindle	Swing Over Carriage	Power Required	Weight Crated	Code Word	Price F.O.B. South Bend	Down Payment 20%	12 Equal Monthly Payments
94-C	18 1/2 in.	6 ft.	29 1/2 in.	1 7/8 in.	12 1/2 in.	2 H.P.	2440 lbs.	Sapho	\$713.00	\$142.60	\$49.91
94-D	18 1/2 in.	7 ft.	41 1/2 in.	1 3/8 in.	12 1/2 in.	2 H.P.	2540 lbs.	Setra	738.00	147.60	51.66
94-E	18 1/2 in.	8 ft.	53 1/2 in.	1 3/8 in.	12 1/2 in.	2 H.P.	2640 lbs.	Sibar	763.00	152.60	53.41
94-G	18 1/2 in.	10 ft.	77 1/2 in.	1 1/2 in.	12 1/2 in.	2 H.P.	2840 lbs.	Socks	817.00	163.40	57.19
*94-H	18 1/2 in.	12 ft.	101 1/2 in.	1 1/2 in.	12 1/2 in.	2 H.P.	3140 lbs.	Subwa	895.00	179.00	62.65
*94-K	18 1/2 in.	14 ft.	125 1/2 in.	1 1/2 in.	12 1/2 in.	2 H.P.	3540 lbs.	Syogi	957.00	191.40	66.99

Monthly Payments Include carrying charge.

*Lathes with 12-foot and 14-foot beds are equipped with center leg.

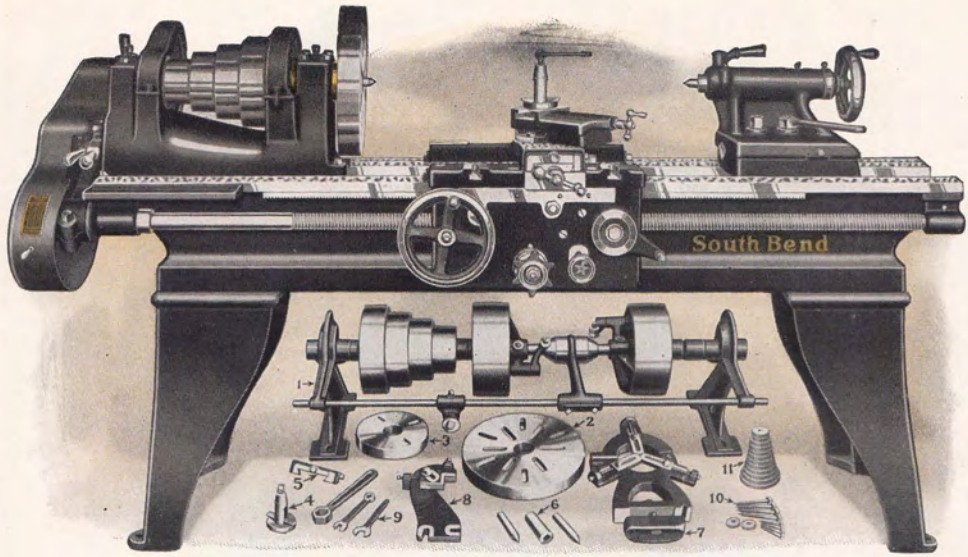

Regular equipment, as illustrated under Lathe, is included in price of Lathe

18-inch Standard Change Gear New Model South Bend Lathe

Back Geared, Screw Cutting Lathe, Countershaft Drive

The New Model 18-inch Standard Change Back Geared Screw Cutting Lathe has the power for heavy production work, manufacturing, and precision and accuracy for fine tool room work. It is an excellent tool for all kinds of work in the machine shop.

The New Headstock is back geared, reinforced and webbed, insuring strength and rigidity. Eight spindle speeds are provided, four direct and four back geared. See page 6.

The Headstock Spindle is made of high carbon steel finished ground with a $1\frac{1}{8}$ -inch hole its entire length. See page 8.

The Phosphor Bronze Bearings for Head Spindle are hand scraped to a perfect bearing, are adjustable for wear and are equipped with oilers. See page 8.

The New Model Standard Change Gear Lathe is equipped with a set of independent change gears to cut the following screw threads per inch, right or left-hand, including $11\frac{1}{2}$ pipe thread: 2, 3, 4, 5, 6, 7, 8, 9, 10, 11, $11\frac{1}{2}$, 12, 13, 14, 16, 18, 20, 22, 24, 26, 28, 30, 32, 36 and 40. By compounding the gears furnished many other threads can be cut. See page 53.

LATHE FEATURES

Independent change gears for threads and feeds.
 Back geared headstock gives 8 spindle speeds.
 Automatic cross feed, automatic longitudinal feed.
 Hollow spindle, made of special carbon steel.
 Spring latch reverse for feeds and threads.
 Phosphor bronze bearings for spindle.
 Graduated compound rest swivels to any angle.
 Tailstock is arranged for set-over for taper turning.
 Graduated collar on cross feed and compound rest screw.
 Precision lead screw for cutting accurate threads.

The New Tailstock has a set-over for taper turning. The binding lever locks the spindle without disturbing the alignment of centers. The center is hardened. See page 6.

The New Apron has automatic cross and longitudinal feeds, and half nuts for thread cutting. An automatic safety interlock prevents the half nuts and automatic feeds from being engaged at the same time. See page 7.

The Precision Lead Screw $1\frac{1}{8}$ -inch diam., 4 threads per inch Acme Standard, is cut on a special machine equipped with a master lead screw which insures accuracy. The threads of the lead screw are used for thread cutting only as the spline in the lead screw drives a worm in the apron which operates both automatic feeds. See page 7.

The Regular Equipment included with each 18-inch Standard Change Gear Lathe consists of: Double Friction Countershaft, Set of Independent Change Gears, Large and Small Face Plates, Tool Post Complete, Adjustable Thread Cutting Stop, Two Lathe Centers and Spindle Sleeve, Center Rest, Follower Rest and Wrenches. See pages 52-53.

LATHE SPECIFICATIONS

Head and Tail Spindle Centers.....No. 3, Morse Taper
 Size of Spindle Nose..... $2\frac{3}{8}$ in. diam., 6 Threads
 Precision Acme Lead Screw..... $1\frac{1}{8}$ in. diam., 4 Threads
 Screw Thread Cutting Range.....2 to 40 per inch
 Width of Cone Pulley Belt..... $2\frac{1}{2}$ in.
 Spindle Speeds.....18, 28, 45, 70, 135, 200, 300, 465 R.P.M.
 Countershaft Speed.....200 R.P.M.
 Countershaft Friction Clutch Pulleys.....12 in. x $4\frac{1}{2}$ in.
 Angular Travel of Compound Rest Top..... $4\frac{1}{2}$ in.
 Size of Lathe Tool Shank..... $\frac{1}{2}$ in. x $1\frac{1}{8}$ in.

Easy Payment Prices 18-in. Standard Change Gear Lathe Including Overhead Countershaft and Equipment

No. of Lathe	Swing Over Bed	Length of Bed	Between Centers	Hole Thru Spindle	Swing Over Carriage	Power Required	Weight Crated	Code Word	Price F.O.B. South Bend	Down Payment 20%	12 Equal Monthly Payments
43-C	18 $\frac{1}{2}$ in.	6 ft.	29 $\frac{1}{2}$ in.	1 $\frac{1}{8}$ in.	12 $\frac{1}{2}$ in.	2 H.P.	2400 lbs.	Sagah	\$623.00	\$124.60	\$43.61
43-D	18 $\frac{1}{2}$ in.	7 ft.	41 $\frac{1}{2}$ in.	1 $\frac{1}{8}$ in.	12 $\frac{1}{2}$ in.	2 H.P.	2500 lbs.	Selhoe	648.00	129.60	45.36
43-E	18 $\frac{1}{2}$ in.	8 ft.	53 $\frac{1}{2}$ in.	1 $\frac{1}{8}$ in.	12 $\frac{1}{2}$ in.	2 H.P.	2600 lbs.	Slati	673.00	134.60	47.11
43-G	18 $\frac{1}{2}$ in.	10 ft.	77 $\frac{1}{2}$ in.	1 $\frac{1}{8}$ in.	12 $\frac{1}{2}$ in.	2 H.P.	2800 lbs.	Sombu	727.00	145.40	50.89
*43-H	18 $\frac{1}{2}$ in.	12 ft.	101 $\frac{1}{2}$ in.	1 $\frac{1}{8}$ in.	12 $\frac{1}{2}$ in.	2 H.P.	3100 lbs.	Sumpt	805.00	161.00	56.35
*43-K	18 $\frac{1}{2}$ in.	14 ft.	125 $\frac{1}{2}$ in.	1 $\frac{1}{8}$ in.	12 $\frac{1}{2}$ in.	2 H.P.	3500 lbs.	Sylog	867.00	173.40	60.69

Monthly Payments include carrying charge.

*Lathes with 12-foot and 14-foot beds are equipped with center leg.

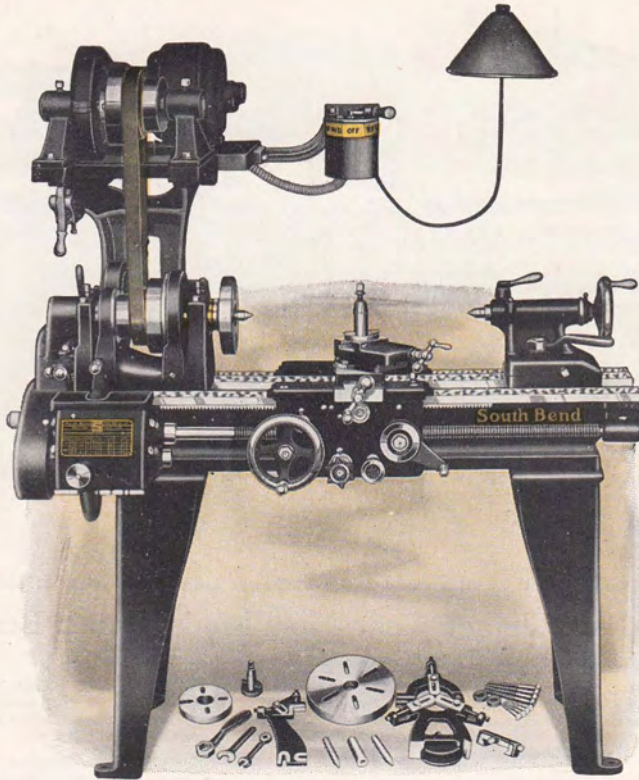

Reversing Motor, Reversing Switch and Lathe Equipment are included in price

9-inch New Model Silent Chain Motor Driven Lathe

The 9-inch New Model South Bend Silent Chain Motor Driven Lathe is a practical tool for light accurate work. It is capable of turning out work with the finest accuracy and precision. The lathe is a complete unit requiring no extra driving equipment of any kind. It occupies only the same amount of floor space as the regular belt driven lathe and is ready to operate as soon as it is connected to the electric current.

The Silent Chain Motor Driven Lathe shown above is exactly the same as the 9-inch lathe illustrated and described on page 10 except that it is equipped with the Silent Chain Motor Drive which is completely illustrated and described on pages 28 and 29. This lathe is furnished in both quick change and standard change gear types. See pages 10 and 11.

Regular Lathe Equipment included in the price of the 9-inch Silent Chain Motor Driven Lathe consists of: Large Face Plate, Small Face Plate, Tool Post Complete, Adjustable Thread Cutting Stop, two Lathe Centers and Spindle Sleeve, Center Rest, Follower Rest, Wrenches and Change Gears with Standard Change Gear Lathes. Also Installation Plans, Floor Plans and book, "How to Run a Lathe." See page 53.

Electrical Equipment included in the price of the 9-inch Silent Chain Motor Driven Lathe consists of a 1/4 H. P. Reversing Motor 1200 R. P. M. (Westinghouse, General Electric or equal make), Reversing Switch (drum type), Wiring between Motor and Switch, Flexible Metal Conduit, Wiring Diagram and Leather Belt. For description of Motor Drive Lathe see pages 28 and 29.

Easy Payment Prices of 9-inch New Model South Bend Silent Chain Motor Driven Lathes

Prices include Lathe Equipment, Reversing Motor, Reversing Switch and Leather Belt

Swing Over Bed	Length of Bed	Size of Motor	Approx. Weight	Catalog No. of Lathe	Code Word	With 3 Phase, 60 Cycle A.C. Motor			With 1 Phase, 60 Cycle A.C. Motor			With Direct Current Motor		
						Price F. O. B. South Bend	Down Payment 20%	12 Equal Monthly Payments	Price F. O. B. South Bend	Down Payment 20%	12 Equal Monthly Payments	Price F. O. B. South Bend	Down Payment 20%	12 Equal Monthly Payments
9-inch Quick Change Gear Silent Chain Motor Driven Lathes														
9 1/4 in.	2 1/2 ft.	1/4 H.P.	670 lbs.	382-X	Baten	\$392.00	\$78.40	\$27.44	\$407.00	\$81.40	\$28.49	\$400.00	\$80.00	\$28.00
9 1/4 in.	3 ft.	1/4 H.P.	690 lbs.	382-Y	Betal	398.00	79.60	27.86	413.00	82.60	28.91	406.00	81.20	28.42
9 1/4 in.	3 1/2 ft.	1/4 H.P.	710 lbs.	382-Z	Binks	404.00	80.80	28.28	419.00	83.80	29.33	412.00	82.40	28.84
9 1/4 in.	4 ft.	1/4 H.P.	730 lbs.	382-A	Blast	411.00	82.20	28.77	426.00	85.20	29.82	419.00	83.80	29.33
9 1/4 in.	4 1/2 ft.	1/4 H.P.	750 lbs.	382-R	Bolan	419.00	83.80	29.33	434.00	86.80	30.38	427.00	85.40	29.89
9-inch Standard Change Gear Silent Chain Motor Driven Lathes														
9 1/4 in.	2 1/2 ft.	1/4 H.P.	660 lbs.	331-X	Bread	\$347.00	\$69.40	\$24.29	\$362.00	\$72.40	\$25.34	\$355.00	\$71.00	\$24.85
9 1/4 in.	3 ft.	1/4 H.P.	680 lbs.	331-Y	Bucar	353.00	70.60	24.71	368.00	73.60	25.76	361.00	72.20	25.27
9 1/4 in.	3 1/2 ft.	1/4 H.P.	700 lbs.	331-Z	Bvint	359.00	71.80	25.13	374.00	74.80	26.18	367.00	73.40	25.69
9 1/4 in.	4 ft.	1/4 H.P.	720 lbs.	331-A	Bwity	366.00	73.20	25.62	381.00	76.20	26.67	374.00	74.80	26.18
9 1/4 in.	4 1/2 ft.	1/4 H.P.	740 lbs.	331-R	Bzumpl	374.00	74.80	26.18	389.00	77.80	27.23	382.00	76.40	26.74

Monthly Payments include carrying charge.

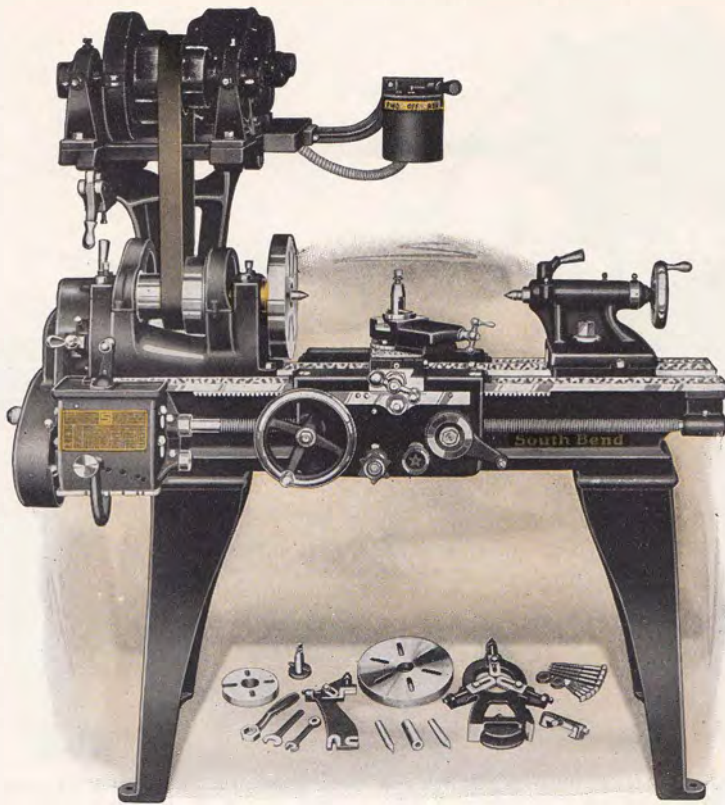

Reversing Motor, Reversing Switch and Lathe Equipment are included in price

11-inch New Model Silent Chain Motor Driven Lathe

The 11-inch New Model South Bend Silent Chain Motor Driven Lathe is an excellent tool for light production work in manufacturing. It will meet the most exacting requirements in the tool room. The lathe is a complete unit requiring no extra driving equipment of any kind. It occupies only the same amount of floor space as the regular belt driven lathe and is ready to operate as soon as it is connected to the electric current.

The Silent Chain Motor Driven Lathe shown above is exactly the same as the 11-inch lathe illustrated and described on page 12 except that it is equipped with the Silent Chain Motor Drive which is completely illustrated and described on pages 28 and 29. This lathe is furnished in both quick change and standard change gear types. See pages 12 and 13.

Regular Lathe Equipment included in the price of the 11-inch Silent Chain Motor Driven Lathe consists of: Large Face Plate, Small Face Plate, Tool Post Complete, Adjustable Thread Cutting Stop, two Lathe Centers and Spindle Sleeve, Center Rest, Follower Rest, Wrenches and Change Gears with Standard Change Gear Lathes. Also Installation Plans, Floor Plans and book, "How to Run a Lathe." See page 53.

Electrical Equipment included in the price of the 11-inch Silent Chain Motor Driven Lathe consists of a 1/2 H. P. Reversing Motor 1200 R. P. M. (Westinghouse, General Electric or equal make), Reversing Switch (drum type), Wiring between Motor and Switch, Flexible Metal Conduit, Wiring Diagram and Leather Belt. For description of Motor Drive Lathe see pages 28 and 29.

Easy Payment Prices of 11-inch New Model South Bend Silent Chain Motor Driven Lathes
Prices Include Lathe Equipment, Reversing Motor, Reversing Switch and Leather Belt

Swing Over Bed	Length of Bed	Size of Motor	Approx. Weight Crated	Catalog No. of Lathe	Code Word	With 3 Phase, 60 Cycle A.C. Motor			With 1 Phase, 60 Cycle A.C. Motor			With Direct Current Motor			
						Price F.O.B. South Bend	Down Payment 20%	12 Equal Monthly Payments	Price F.O.B. South Bend	Down Payment 20%	12 Equal Monthly Payments	Price F.O.B. South Bend	Down Payment 20%	12 Equal Monthly Payments	
11-Inch Quick Change Gear Silent Chain Motor Driven Lathes															
11 1/4 in.	3 ft.	1/2 H.P.	870 lbs.	384-Y	Eandow	\$484.00	\$ 96.80	\$33.88	\$12.00	\$102.40	\$35.84	\$495.00	\$ 99.00	\$34.65	
11 1/4 in.	3 1/2 ft.	1/2 H.P.	895 lbs.	384-Z	Ebert	491.00	98.20	34.37	519.00	103.80	36.33	502.00	100.40	35.14	
11 1/4 in.	4 ft.	1/2 H.P.	920 lbs.	384-A	Ecrow	498.00	99.60	34.86	526.00	105.20	36.82	509.00	101.80	35.63	
11 1/4 in.	5 ft.	1/2 H.P.	1035 lbs.	384-B	Edaze	514.00	102.80	35.98	542.00	108.40	37.94	525.00	105.00	36.75	
11 1/4 in.	5 1/2 ft.	1/2 H.P.	1060 lbs.	384-S	Etipk	523.00	104.60	36.61	551.00	110.20	38.57	534.00	106.80	37.38	
11-Inch Standard Change Gear Silent Chain Motor Driven Lathes															
11 1/4 in.	3 ft.	1/2 H.P.	855 lbs.	333-Y	Eham	\$434.00	\$86.80	\$30.38	\$462.00	\$ 92.40	\$32.34	\$445.00	\$89.00	\$31.15	
11 1/4 in.	3 1/2 ft.	1/2 H.P.	880 lbs.	333-Z	Eguil	441.00	88.20	30.87	469.00	93.80	32.83	452.00	90.40	31.64	
11 1/4 in.	4 ft.	1/2 H.P.	905 lbs.	333-A	Ehams	448.00	89.60	31.36	476.00	95.20	33.32	459.00	91.80	32.13	
11 1/4 in.	5 ft.	1/2 H.P.	1020 lbs.	333-B	Eioaw	464.00	92.80	32.48	492.00	98.40	34.44	475.00	95.00	33.25	
11 1/4 in.	5 1/2 ft.	1/2 H.P.	1045 lbs.	333-S	Eiphx	473.00	94.60	33.11	501.00	100.20	35.07	484.00	96.80	33.88	

Monthly Payments include carrying charge.

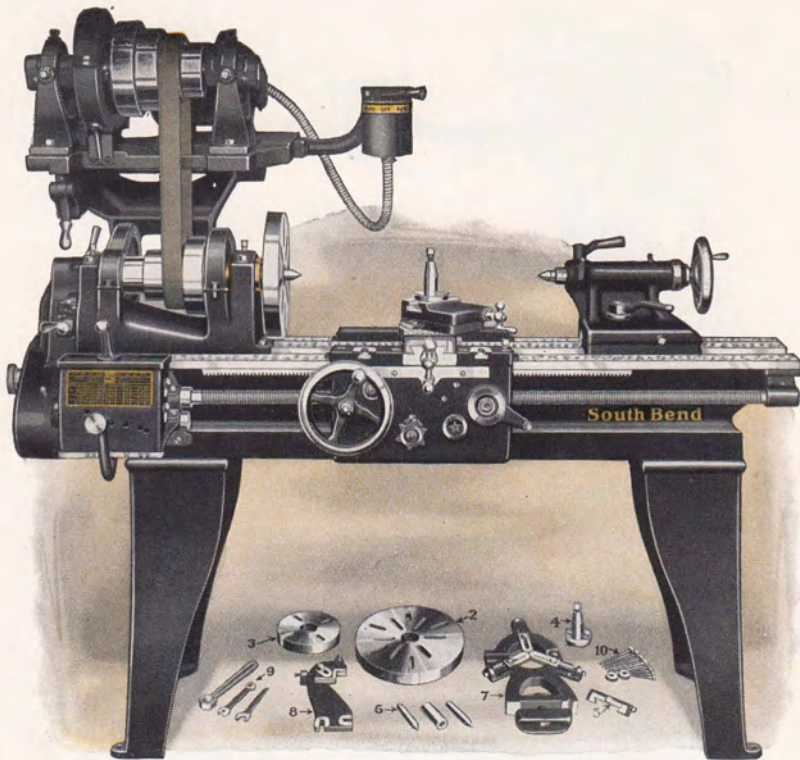

Reversing Motor, Reversing Switch and Lathe Equipment are included in price

13-inch New Model Silent Chain Motor Driven Lathe

The 13-inch New Model South Bend Silent Chain Motor Driven Lathe is a practical tool for the factory on production work. It will handle the finest precision tool, die and gauge work. The lathe is a complete unit requiring no extra driving equipment of any kind. It occupies only the same amount of floor space as the regular belt driven lathe and is ready to operate as soon as it is connected to the electric current.

The Silent Chain Motor Driven Lathe shown above is exactly the same as the 13-inch lathe illustrated and described on page 14 except that it is equipped with the Silent Chain Motor Drive which is completely illustrated and described on pages 28 and 29. This lathe is furnished in both quick change and standard change gear types. See pages 14 and 15.

Regular Lathe Equipment included in the price of the 13-inch Silent Chain Motor Driven Lathe consists of: Large Face Plate, Small Face Plate, Tool Post Complete, Adjustable Thread Cutting Stop, two Lathe Centers and Spindle Sleeve, Center Rest, Follower Rest, Wrenches and Change Gears with Standard Change Gear Lathes. Also Installation Plans, Floor Plans and book, "How to Run a Lathe." See page 53.

Electrical Equipment included in the price of the 13-inch Silent Chain Motor Driven Lathe consists of a ¼ H. P. Reversing Motor 1200 R. P. M. (Westinghouse, General Electric or equal make), Reversing Switch (drum type), Wiring between Motor and Switch, Flexible Metal Conduit, Wiring Diagram and Leather Belt. For description of Motor Drive Lathe see pages 28 and 29.

Easy Payment Prices of 13-inch New Model South Bend Silent Chain Motor Driven Lathes
Prices include Lathe Equipment, Reversing Motor, Reversing Switch and Leather Belt

Swing Over Bed	Length of Bed	Size of Motor	Approx. Weight Crated	Catalog No. of Lathe	Code Word	With 3 Phase, 60 Cycle A.C. Motor			With 1 Phase, 60 Cycle A.C. Motor			With Direct Current Motor		
						Price F.O.B. South Bend	Down Payment 20%	12 Equal Monthly Payments	Price F.O.B. South Bend	Down Payment 20%	12 Equal Monthly Payments	Price F.O.B. South Bend	Down Payment 20%	12 Equal Monthly Payments
13-inch Quick Change Gear Silent Chain Motor Driven Lathes														
13¼ in.	4 ft.	¾ H.P.	1460 lbs.	386-A	Gazed	\$587.00	\$117.40	\$41.09	\$630.00	\$126.00	\$44.10	\$598.00	\$119.60	\$41.86
13¼ in.	5 ft.	¾ H.P.	1510 lbs.	386-B	Gemic	602.00	120.40	42.14	645.00	129.00	45.15	613.00	122.60	42.91
13¼ in.	6 ft.	¾ H.P.	1560 lbs.	386-C	Giraf	617.00	123.40	43.19	660.00	132.00	46.20	628.00	125.60	43.96
13¼ in.	7 ft.	¾ H.P.	1610 lbs.	386-D	Gotam	634.00	126.80	44.36	677.00	135.40	47.39	645.00	129.00	45.15
13¼ in.	8 ft.	¾ H.P.	1685 lbs.	386-E	Gneza	653.00	130.60	45.71	696.00	139.20	48.72	664.00	132.80	46.48
13-inch Standard Change Gear Silent Chain Motor Driven Lathes														
13¼ in.	4 ft.	¾ H.P.	1440 lbs.	335-A	Grub	\$527.00	\$105.40	\$36.89	\$570.00	\$114.00	\$39.90	\$538.00	\$107.60	\$37.66
13¼ in.	5 ft.	¾ H.P.	1490 lbs.	335-B	Guest	542.00	108.40	37.94	585.00	117.00	40.95	553.00	110.60	38.71
13¼ in.	6 ft.	¾ H.P.	1540 lbs.	335-C	Gramp	557.00	111.40	38.99	600.00	120.00	42.00	568.00	113.60	39.76
13¼ in.	7 ft.	¾ H.P.	1590 lbs.	335-D	Grief	574.00	114.80	40.18	617.00	123.40	43.19	585.00	117.00	40.95
13¼ in.	8 ft.	¾ H.P.	1665 lbs.	335-E	Gwilt	593.00	118.60	41.51	636.00	127.20	44.52	604.00	120.80	42.28

For price of 13-inch Silent Chain Motor Driven Lathe with Gap Bed add \$65.00 to above prices. See pages 50 and 51. Monthly Payments include carrying charge.

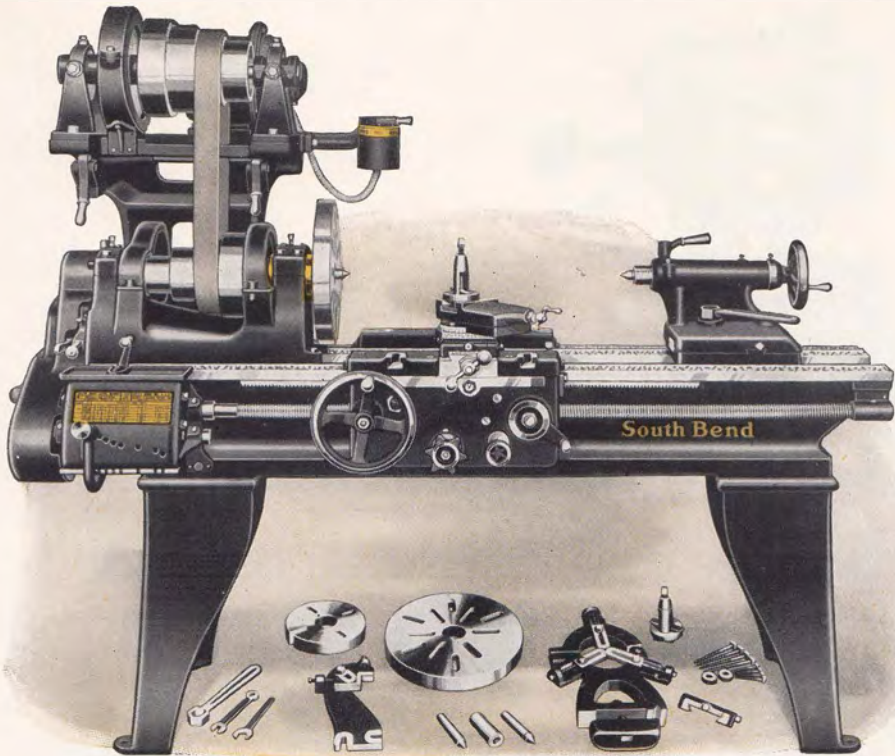

Reversing Motor, Reversing Switch and Lathe Equipment are included in price

15-inch New Model Silent Chain Motor Driven Lathe

The 15-inch New Model South Bend Silent Chain Motor Driven Lathe has the power for production work in manufacturing, the precision and accuracy for fine tool work. The lathe is a complete unit requiring no extra driving equipment of any kind. It occupies only the same amount of floor space as the regular belt driven lathe and is ready to operate as soon as it is connected to the electric current.

The Silent Chain Motor Driven Lathe shown above is exactly the same as the 15-inch lathe illustrated and described on page 16 except that it is equipped with the Silent Chain Motor Drive which is completely illustrated and described on pages 28 and 29. This lathe is furnished in both quick change and standard change gear types. See pages 16 and 17.

Regular Lathe Equipment included in the price of the 15-inch Silent Chain Motor Driven Lathe consists of: Large Face Plate, Small Face Plate, Tool Post Complete, Adjustable Thread Cutting Stop, two Lathe Centers and Spindle Sleeve, Center Rest, Follower Rest, Wrenches and Change Gears with Standard Change Gear Lathes. Also Installation Plans, Floor Plans and book, "How to Run a Lathe." See page 53.

Electrical Equipment included in the price of the 15-inch Silent Chain Motor Driven Lathe consists of a 1 H. P. Reversing Motor 1200 R. P. M. (Westinghouse, General Electric or equal make), Reversing Switch (drum type), Wiring between Motor and Switch, Flexible Metal Conduit, Wiring Diagram and Leather Belt. For description of Motor Drive Lathe see pages 28 and 29.

Easy Payment Prices of 15-inch New Model South Bend Silent Chain Motor Driven Lathes

Prices Include Lathe Equipment, Reversing Motor, Reversing Switch and Leather Belt

Swing Over Bed	Length of Bed	Size of Motor	Approx. Weight Crated	Catalog No. of Lathe	Code Word	With 3 Phase, 60 Cycle A.C. Motor			With 1 Phase, 60 Cycle A.C. Motor			With Direct Current Motor		
						Price F. O. B. South Bend	Down Payment 20%	12 Equal Monthly Payments	Price F. O. B. South Bend	Down Payment 20%	12 Equal Monthly Payments	Price F. O. B. South Bend	Down Payment 20%	12 Equal Monthly Payments
15-inch Quick Change Gear Silent Chain Motor Driven Lathes														
15 1/4 in.	5 ft.	1 H.P.	1925 lbs.	388-B	Labor	\$702.00	\$140.40	\$49.14	\$731.00	\$146.20	\$51.17	\$780.00	\$156.00	\$54.60
15 1/4 in.	6 ft.	1 H.P.	2025 lbs.	388-C	Leone	720.00	144.00	50.40	749.00	149.80	52.43	798.00	159.60	55.86
15 1/4 in.	7 ft.	1 H.P.	2075 lbs.	388-D	Lepor	738.00	147.60	51.66	767.00	153.40	53.69	816.00	163.20	57.12
15 1/4 in.	8 ft.	1 H.P.	2150 lbs.	388-E	Licel	758.00	151.60	53.06	787.00	157.40	55.09	836.00	167.20	58.52
15 1/4 in.	10 ft.	1 H.P.	2300 lbs.	388-G	Lindy	802.00	160.40	56.14	831.00	166.20	58.17	880.00	176.00	61.60
15-inch Standard Change Gear Silent Chain Motor Driven Lathes														
15 1/4 in.	5 ft.	1 H.P.	1908 lbs.	339-B	Loane	\$627.00	\$125.40	\$43.89	\$656.00	\$131.20	\$45.92	\$705.00	\$141.00	\$49.35
15 1/4 in.	6 ft.	1 H.P.	2000 lbs.	339-C	Loane	645.00	129.00	45.15	674.00	134.80	47.18	723.00	144.60	50.61
15 1/4 in.	7 ft.	1 H.P.	2050 lbs.	339-D	Lotus	663.00	132.60	46.41	692.00	138.40	48.44	741.00	148.20	51.87
15 1/4 in.	8 ft.	1 H.P.	2125 lbs.	339-E	Luela	683.00	136.60	47.81	712.00	142.40	49.84	761.00	152.20	53.27
15 1/4 in.	10 ft.	1 H.P.	2275 lbs.	339-G	Lyric	727.00	145.40	50.89	756.00	151.20	52.92	805.00	161.00	56.35

For price of 15-inch Silent Chain Motor Driven Lathe with Gap Bed add \$75.00 to above prices. See pages 50 and 51. Monthly Payments include carrying charge.

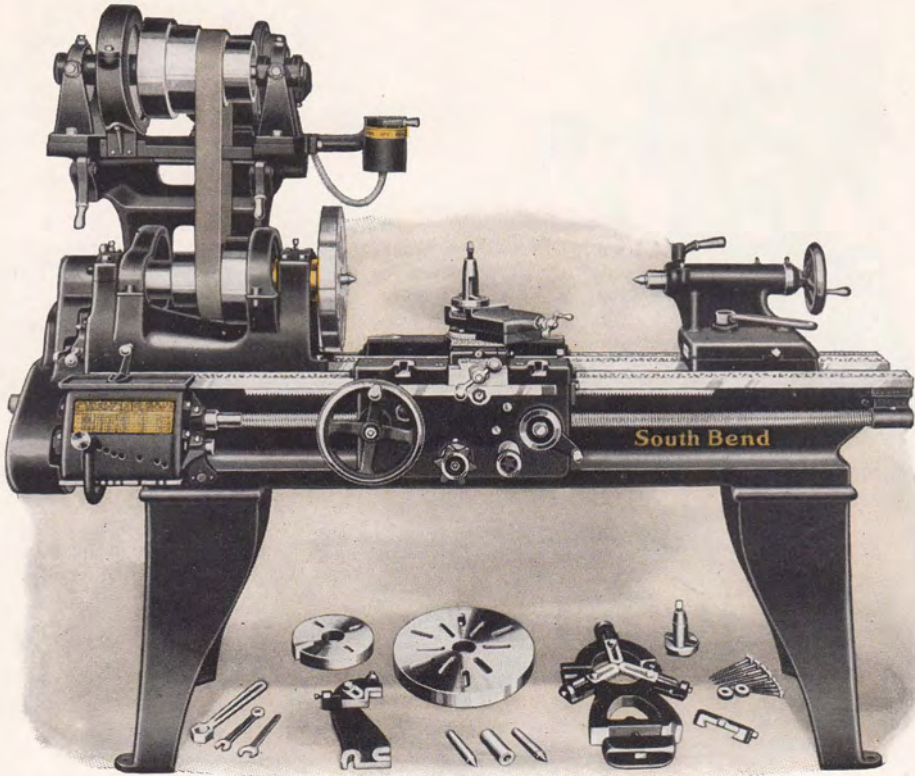

Reversing Motor, Reversing Switch and Lathe Equipment are included in price

16-inch New Model Silent Chain Motor Driven Lathe

The 16-inch New Model South Bend Silent Chain Motor Driven Lathe has the power for heavy production and general machine work and the precision for fine tool, die and gauge work. The lathe is a complete unit requiring no extra driving equipment of any kind. It occupies only the same amount of floor space as the regular belt driven lathe and is ready to operate as soon as it is connected to the electric current.

The Silent Chain Motor Driven Lathe shown above is exactly the same as the 16-inch lathe illustrated and described on page 18 except that it is equipped with the Silent Chain Motor Drive which is completely illustrated and described on pages 28 and 29. This lathe is furnished in both quick change and standard change gear types. See pages 18 and 19.

Regular Lathe Equipment included in the price of the 16-inch Silent Chain Motor Driven Lathe consists of: Large Face Plate, Small Face Plate, Tool Post Complete, Adjustable Thread Cutting Stop, two Lathe Centers and Spindle Sleeve, Center Rest, Follower Rest, Wrenches and Change Gears with Standard Change Gear Lathes. Also Installation Plans, Floor Plans and book, "How to Run a Lathe." See page 53.

Electrical Equipment included in the price of the 16-inch Silent Chain Motor Driven Lathe consists of a 1 H. P. Reversing Motor 1200 R. P. M. (Westinghouse, General Electric or equal make), Reversing Switch (drum type), Wiring between Motor and Switch, Flexible Metal Conduit, Wiring Diagram and Leather Belt. For description of Motor Drive Lathe see pages 28 and 29.

Easy Payment Prices of 16-inch New Model South Bend Silent Chain Motor Driven Lathes

Prices Include Lathe Equipment, Reversing Motor, Reversing Switch and Leather Belt

Swing Over Bed	Length of Bed	Size of Motor	Approx. Weight Crated	Catalog No. of Lathe	Code Word	With 3 Phase, 60 Cycle A.C. Motor			With 1 Phase, 60 Cycle A.C. Motor			With Direct Current Motor		
						Price F. O. B. South Bend	Down Payment 20%	12 Equal Monthly Payments	Price F. O. B. South Bend	Down Payment 20%	12 Equal Monthly Payments	Price F. O. B. South Bend	Down Payment 20%	12 Equal Monthly Payments
16-inch Quick Change Gear Silent Chain Motor Driven Lathes														
16 1/4 in.	6 ft.	1 H.P.	2310 lbs.	392-C	Madge	\$777.00	\$155.40	\$54.39	\$806.00	\$161.20	\$56.42	\$ 855.00	\$171.00	\$59.85
16 1/4 in.	7 ft.	1 H.P.	2390 lbs.	392-D	Magpi	797.00	159.40	55.79	826.00	165.20	57.82	875.00	175.00	61.25
16 1/4 in.	8 ft.	1 H.P.	2470 lbs.	392-E	Mears	817.00	163.40	57.19	846.00	169.20	59.22	895.00	178.00	62.65
16 1/4 in.	10 ft.	1 H.P.	2630 lbs.	392-G	Metro	861.00	172.20	60.27	890.00	178.00	62.30	939.00	187.80	65.73
16 1/4 in.	12 ft.	1 H.P.	2890 lbs.	392-H	Mires	924.00	184.80	64.68	953.00	190.60	66.71	1002.00	200.40	70.14
16-inch Standard Change Gear Silent Chain Motor Driven Lathes														
16 1/4 in.	6 ft.	1 H.P.	2275 lbs.	341-C	Mirac	\$692.00	\$139.40	\$48.79	\$726.00	\$145.20	\$50.82	\$775.00	\$155.00	\$54.25
16 1/4 in.	7 ft.	1 H.P.	2355 lbs.	341-D	Meats	717.00	143.40	50.19	746.00	149.20	52.22	795.00	159.00	55.65
16 1/4 in.	8 ft.	1 H.P.	2435 lbs.	341-E	Moral	737.00	147.40	51.59	766.00	153.20	53.62	815.00	163.00	57.05
16 1/4 in.	10 ft.	1 H.P.	2595 lbs.	341-G	Music	781.00	156.20	54.67	810.00	162.00	56.70	859.00	171.80	60.13
16 1/4 in.	12 ft.	1 H.P.	2855 lbs.	341-H	Mybeu	844.00	168.80	59.08	873.00	174.60	61.11	922.00	184.40	64.54

For price of 16-inch Silent Chain Motor Driven Lathe with Gap Bed add \$85.00 to above prices. See pages 50 and 51. Monthly Payments include carrying charge.

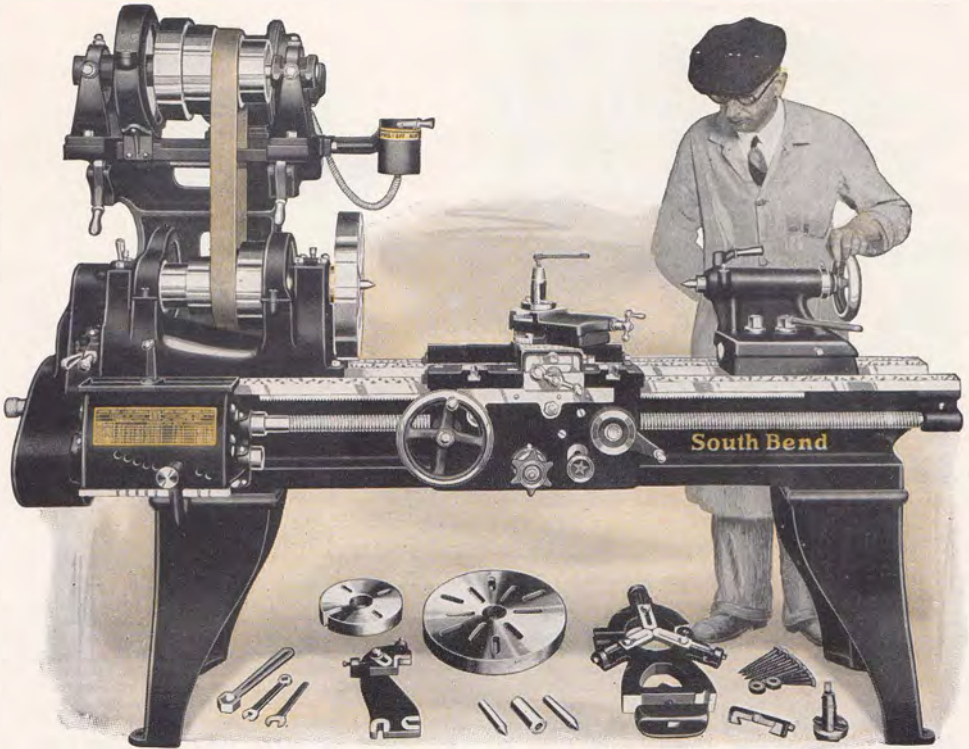

Reversing Motor, Reversing Switch and Lathe Equipment are included in price

18-inch New Model Silent Chain Motor Driven Lathe

The 18-inch New Model South Bend Silent Chain Motor Driven Lathe has the power, accuracy and precision for heavy machine work in the machine shop, tool room and manufacturing plant. The lathe is a complete unit requiring no extra driving equipment of any kind. It occupies only the same amount of floor space as the regular belt driven lathe and is ready to operate as soon as it is connected to the electric current.

The Silent Chain Motor Driven Lathe shown above is exactly the same as the 18-inch lathe illustrated and described on page 20 except that it is equipped with the Silent Chain Motor Drive which is completely illustrated and described on pages 28 and 29. This lathe is furnished in both quick change and standard change gear types. See pages 20 and 21.

Regular Lathe Equipment included in the price of the 18-inch Silent Chain Motor Driven Lathe consists of: Large Face Plate, Small Face Plate, Tool Post Complete, Adjustable Thread Cutting Stop, two Lathe Centers and Spindle Sleeve, Center Rest, Follower Rest, Wrenches and Change Gears with Standard Change Gear Lathes. Also Installation Plans, Floor Plans and book, "How to Run a Lathe." See page 53.

Electrical Equipment included in the price of the 18-inch Silent Chain Motor Driven Lathe consists of a 2 H. P. Reversing Motor 1200 R. P. M. (Westinghouse, General Electric or equal make), Reversing Switch (drum type), Wiring between Motor and Switch, Flexible Metal Conduit, Wiring Diagram and Leather Belt. For description of Motor Drive Lathe see pages 28 and 29.

Easy Payment Prices of 18-inch New Model South Bend Silent Chain Motor Driven Lathes

Prices include Lathe Equipment, Reversing Motor, Reversing Switch and Leather Belt

Swing Over Bed	Length of Bed	Size of Motor	Approx. Weight Crated	Catalog No. of Lathe	Code Word	With 3 Phase, 60 Cycle A.C. Motor			With 1 Phase, 60 Cycle A.C. Motor			With Direct Current Motor		
						Price F.O.B. South Bend	Down Payment 20%	12 Equal Monthly Payments	Price F.O.B. South Bend	Down Payment 20%	12 Equal Monthly Payments	Price F.O.B. South Bend	Down Payment 20%	12 Equal Monthly Payments
18-inch Quick Change Gear Silent Chain Motor Driven Lathes														
18 1/4 in.	6 ft.	2 H.P.	3040 lbs.	394-C	Sacks	\$ 947.00	\$189.40	\$66.29	\$ 999.00	\$199.80	\$69.93	\$1044.00	\$208.80	\$73.08
18 1/4 in.	7 ft.	2 H.P.	3140 lbs.	394-D	Sarge	972.00	194.40	68.04	1024.00	204.80	71.68	1069.00	213.80	74.83
18 1/4 in.	8 ft.	2 H.P.	3240 lbs.	394-E	Semin	997.00	199.40	69.79	1049.00	209.80	73.43	1094.00	218.80	76.58
18 1/4 in.	10 ft.	2 H.P.	3440 lbs.	394-G	Seoul	1051.00	210.20	73.57	1103.00	220.60	77.21	1148.00	229.60	80.36
18 1/4 in.	12 ft.	2 H.P.	3740 lbs.	394-H	Simpe	1129.00	225.80	79.03	1181.00	236.20	82.67	1226.00	245.20	85.82
18 1/4 in.	14 ft.	2 H.P.	4110 lbs.	394-K	Stuks	1191.00	238.20	83.37	1243.00	248.60	87.01	1288.00	257.60	90.16
18-inch Standard Change Gear Silent Chain Motor Driven Lathes														
18 1/4 in.	6 ft.	2 H.P.	3000 lbs.	343-C	Sober	\$ 857.00	\$171.40	\$59.99	\$ 909.00	\$181.80	\$63.63	\$ 954.00	\$190.80	\$66.78
18 1/4 in.	7 ft.	2 H.P.	3100 lbs.	343-D	Sorel	882.00	176.40	61.74	924.00	186.80	65.38	979.00	195.80	68.53
18 1/4 in.	8 ft.	2 H.P.	3200 lbs.	343-E	Sonro	907.00	181.40	63.49	959.00	191.80	67.13	1004.00	200.80	70.28
18 1/4 in.	10 ft.	2 H.P.	3400 lbs.	343-G	Suere	961.00	192.20	67.27	1013.00	202.60	70.91	1058.00	211.60	74.06
18 1/4 in.	12 ft.	2 H.P.	3700 lbs.	343-H	Sugar	1039.00	207.80	72.73	1091.00	218.20	76.37	1136.00	227.20	79.52
18 1/4 in.	14 ft.	2 H.P.	4100 lbs.	343-K	Synth	1101.00	220.20	77.07	1153.00	230.60	80.71	1198.00	239.60	83.86

For price of 18-inch Silent Chain Motor Driven Lathe with Gap Bed add \$100.00 to above prices. See pages 50 and 51. Monthly Payments include carrying charge.

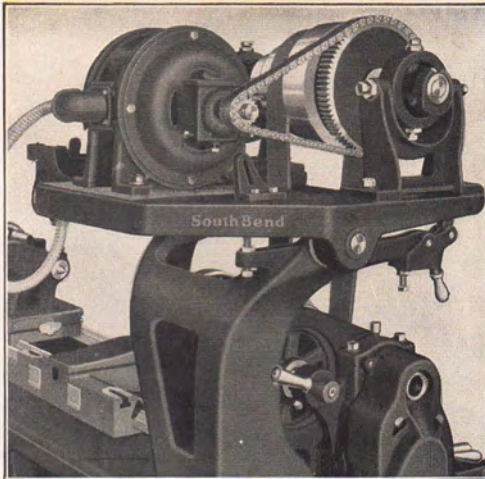

Silent Chain Mechanism with Gear Guard Removed

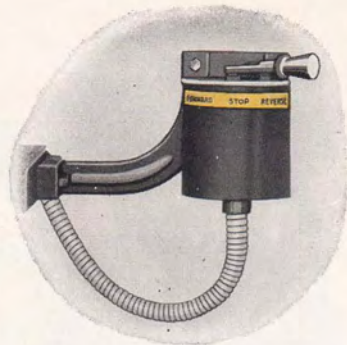

Reversing Switch (Drum Type)

The lever operates the switch in a rotary motion, left for starting, center for stopping and right for reversing the rotation of the lathe spindle and lead screw. This switch is included in the price of all types of Motor Driven South Bend Lathes, 9-inch to 18-inch swing.

The New Silent Chain Motor Drive Unit Used on All New Model Silent Chain Motor Driven Lathes

The Reversing Motor is mounted above the lathe where it is free from dirt and chips. A flexible metal conduit encases wiring from motor to switch. The silent chain drive which connects the motor with the upper cone is provided with a felt wick oiler and is entirely enclosed by a gear guard made of cast iron.

The Motor Table which supports the motor and driving cone is held by a heavy bracket mounted directly on the lathe bed. A small lever convenient to the operator allows the motor table to tilt forward and relieve the belt tension for easy shifting. An independent adjustment is provided for taking up the stretch in belt.

The Drum Type Reversing Control Switch is the most practical switch for the efficient operation of a screw cutting lathe. This type of switch is necessary on a Motor Driven Screw Cutting Lathe because of the continual starting, stopping, and reversing of the lathe spindle. See illustration.

Start, Stop and Reverse positions are provided on the switch. Moving switch handle to the left runs lathe forward, to the right reverses the motion of the lathe spindle, and in center is the neutral or stop position.

Push Button Control, using magnetic reversing switches instead of the drum type can be furnished on the New Model Silent Chain Motor Driven Lathes at extra cost. Prices of the various Motor Driven Lathes equipped with push button control and magnetic switches will be furnished on request. However, we recommend the drum type reversing switch for use on a South Bend Silent Chain Motor Driven Lathe.

Quick Change Gear Silent Chain Motor Driven Lathes from 9-inch to 18-inch swing are illustrated in this catalog on pages 22 to 27 inclusive. The Quick Change Gear Box provides a range of 48 screw threads, right or left, from 2 to 112 per inch. It also provides for a wide range of automatic longitudinal feeds and automatic cross feeds. The Gear Box is illustrated and described in detail on page 5.

Reversing Motors from $\frac{1}{4}$ H. P. to 3 H. P. with current specifications shown at bottom of page 29 are carried in stock in our factory. Special electric motors of odd current characteristics, such as 25 cycle, 30 cycle, 40 cycle, 50 cycle, A. C., and 32-volt D. C., motors are not carried in stock but can be secured from the motor manufacturers on short notice.

Electrical Equipment Included in the Price of the Silent Chain Motor Driven Lathes, both Quick Change Gear and Standard Change Gear, consists of 1200 R. P. M. Reversing Motor (Westinghouse, General Electric, or equal make), Reversing Switch, wiring between motor and switch, flexible metal conduit, wiring diagram, and leather belt.

Regular Lathe Equipment included in price of Silent Chain Motor Driven Lathes, Quick Change and Standard Change Gear types, is illustrated on page 53.

Each Motor Driven Lathe is Thoroughly Tested before shipping. We connect the motor and switch, test and inspect the wiring, then operate and test the lathe under its own power. The wiring is encased in a flexible metal conduit and meets the requirements of Underwriter's Specifications. When the lathe arrives it will be ready to operate as soon as connected to current.

The General Design of the Silent Chain Drive used on Silent Chain Motor Driven Lathes 9-inch swing to 18-inch swing, in both straight bed and gap bed types, Standard and Quick Change, is the same on all sizes, although the actual dimensions of the drive unit vary according to the size lathe.

Standard Change Gear Silent Chain Motor Driven Lathes from 9-inch to 18-inch swing are priced on pages 22 to 27 inclusive. These lathes are equipped with Independent Change Gears which provide for cutting right or left hand screw threads from 4 to 40 per inch as shown by the index plate attached to each lathe. The Change Gears also provide for a range of automatic longitudinal feeds and automatic cross feeds.

Horsepower of Motor Required for Driving South Bend Lathes

Size of Lathe.....	9 in.	11 in.	13 in.	15 in.	16 in.	18 in.
Horsepower of Motor.....	$\frac{1}{4}$	$\frac{1}{2}$	$\frac{3}{4}$	1	1	2
Speed of Motor, R.P.M.....	1150 to 1200	1150 to 1200	1150 to 1200	1150 to 1200	1150 to 1200	1150 to 1200

The New Model Silent Chain Motor Driven Lathe

Six Sizes—9-inch to 18-inch Swing—Standard and Quick Change Gear Lathes

The New Model South Bend Silent Chain Motor Driven Lathe is efficient and practical for use in manufacturing plant, tool room, and general machine shop. The lathe is a complete unit requiring no extra driving equipment of any kind. It occupies only the same amount of floor space as the regular belt driven lathe and is ready to operate as soon as it is connected to the electric current.

All Sizes of South Bend Quick Change Gear and Standard Change Gear Lathes illustrated and described on pages 10 to 21 inclusive and Gap Bed Lathes illustrated and described on pages 50 and 51 are furnished in the Silent Chain Motor Drive Pattern. The same specifications and descriptions apply to the Silent Chain Motor Driven Lathes that apply to the Countershaft Driven Lathes, as the only difference between them is in the form of drive.

The Cone Pulleys and Back Gears of the lathe headstock provide a wide range of spindle speeds, eliminating the expense of special variable and adjustable speed motors, allowing standard, constant speed reversing motors to be used.

The Silent Chain Motor Drive used on South Bend Lathes was developed in the shops of the General Electric Company several years ago. It is the ideal electric drive for the screw cutting lathe as it is practical and powerful and eliminates vibration and noise. Power is delivered from the motor through the silent chain and then by belt to the lathe spindle. Driving the spindle cone by the belt does away with all vibration and permits the cutting tool to work efficiently and to leave a smooth surface on the work. The Silent Chain Motor Drive is by far the most popular form of motor drive.

Reversing Motors and Reversing Switches are furnished on all South Bend Motor Driven Lathes in order to provide instantaneous starting, stopping and reversing of the lathe spindle which is so important on a back geared screw cutting lathe. A complete stock of reversing motors is carried at our plant so that prompt delivery can be made. When customers wish to supply their own motors there will be an extra charge made for the special work involved in fitting the motor to the lathe.

How to Order Motor Driven Lathes—All Types

Electric Current Specifications

When Ordering a Motor Driven Lathe give the following information regarding the electric current to be used, so that the proper style and type of reversing motor can be fitted to the lathe.

When giving voltage state the exact voltage of motor wanted. When ordering do not specify 110-220-volt motor as we cannot furnish motors for double voltage rating.

Always Give the Following Information:

—If Alternating Current state exact voltage, phase, cycle, and number of wires.

—If Direct Current state exact voltage only.

You Can Secure your current specifications from the electric power company furnishing your current.

Use Code Words

When Ordering Motor Driven Lathes by telegram or cablegram use code words to indicate motor specifications. The tabulation below shows code words which cover the popular motor specifications.

If your motor specifications differ from those that we list below, give us the exact voltage, phase and cycle.

CODE WORD CURRENT SPECIFICATIONS

Zapin	1-phase, 60 cycle, 110-volt, A. C. Motor
Zbras	1-phase, 60 cycle, 220-volt, A. C. Motor
Zingo	3-phase, 60 cycle, 110-volt, A. C. Motor
Zompe	3-phase, 60 cycle, 220-volt, A. C. Motor
Zurik	115-volt D. C. Motor
Zuwel	230-volt D. C. Motor

Example—Ordering by Code

For Example: When ordering No. 392-E, 16-inch x 8-foot Silent Chain Motor Driven Lathe equipped with 3-phase, 60 cycle, 220-volt, A. C. motor, specify the code words "Mears Zompe." The code word "Mears" covers the Lathe and the code word "Zompe" covers the motor specifications. Any South Bend Motor Driven Lathe can be ordered by code in the same manner.

Prices of Motor Driven Lathes are net f.o.b. South Bend, crated for domestic shipment and include the Regular Lathe Equipment, a 1200 R. P. M. Reversing Motor, Reversing Switch, Wiring between Motor and Switch, Flexible Metal Conduit, and Leather Belt.

Motor Driven Lathes with Double Gap Bed

The New Model South Bend Silent Chain Motor Driven Lathes can be supplied at extra cost with Double Gap Bed.

To figure the prices of Double Gap Bed Silent Chain Motor Driven Lathes, add the price listed below to the price of the corresponding size of Straight Bed Silent Chain Motor Driven Lathe you wish to purchase. (See pages 23 to 27.) Use Catalog Numbers shown in the tabulation below when ordering Silent Chain Motor Driven Lathes with Double Gap Bed.

Extra for Double Gap Bed and Bridge

Catalog Numbers	Size of Lathe	Swing Over Straight Bed	Swing Over Gap	Prices Extra for Gap Bed and Bridge
3635	13 in.	13 1/4 in.	19 in.	\$ 65.00
3639	15 in.	15 1/2 in.	22 in.	75.00
3641	16 in.	16 1/2 in.	24 in.	85.00
3643	18 in.	18 1/2 in.	26 in.	100.00

Complete Gap Lathe Information on pages 50-51.

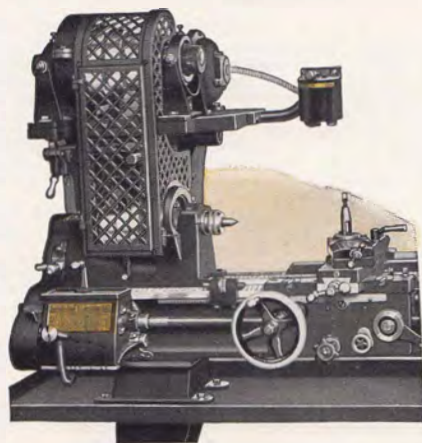

Belt Guard for Silent Chain Motor Drive

The Special Belt Guard shown above can be furnished on all sizes of Silent Chain Motor Driven Lathes, 9-inch to 18-inch inclusive, as additional equipment. The guard completely covers the driving cone, belting and spindle cone.

Net Factory Prices Belt Guards for Silent Chain Motor Driven Lathes

Size of Lathe	Cat. No.	Code Word	Price	Size of Lathe	Cat. No.	Code Word	Price
9 in.	590	Kelat	\$12.00	15 in.	593	Kurey	\$18.00
11 in.	591	Keros	13.50	16 in.	594	Kimet	18.00
13 in.	592	Korin	15.00	18 in.	595	Kajot	22.00

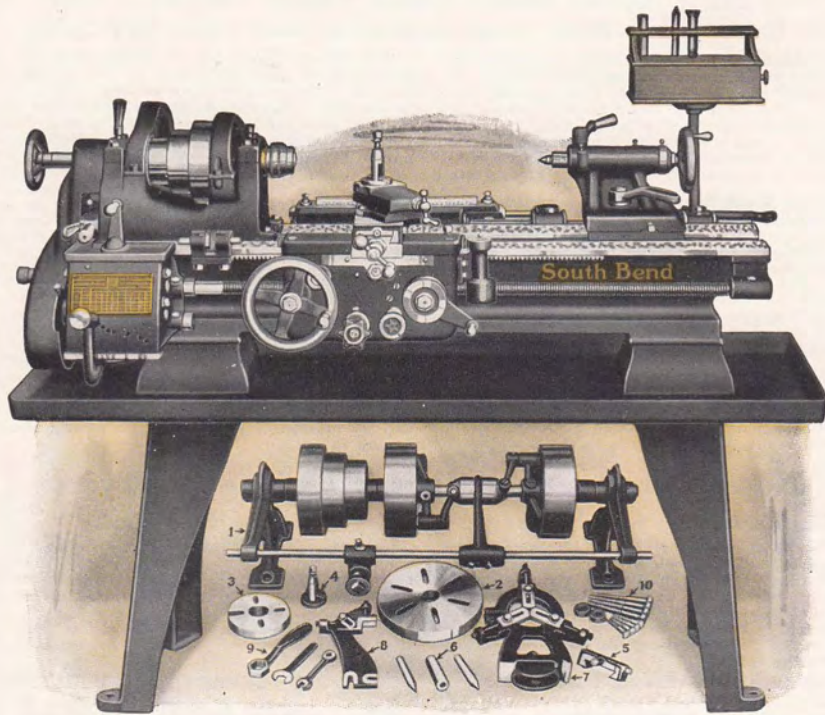

Equipment illustrated under Lathe is included in price of Countershaft Driven Lathe

11-inch New Model Tool Room Precision Lathe

Made in Countershaft and Silent Chain Motor Drives

The New Model South Bend Tool Room Precision Lathe is recommended for fine tool work. It is widely used by many of the largest manufacturing plants in the United States because it is capable of turning out fine tool work with precision and accuracy. This lathe is practical for making precision master taps, thread gauges, special screws, dies, fixtures, tools, etc. It will meet the demands of the expert mechanic on the most accurate work.

For Features, Specifications and detailed description applying to the 11-inch Tool Room Lathe see pages 2 to 9 and 12.

Tool Room Attachments are listed and priced separately so that the customer may select only those required for his work. All attachments are illustrated and described in this catalog.

Regular Equipment included with Lathes priced below consists of: Double Friction Countershaft (not furnished with Motor Driven Lathes), Large Face Plate, Small Face Plate, Tool Post Complete, Adjustable Thread Cutting Stop, two Lathe Centers and Spindle Sleeve, Center Rest, Follower Rest and Wrenches. Also Installation Plans, Floor Plans and book, "How to Run a Lathe." See pages 52 and 53.

Electrical Equipment included in prices of Silent Chain Motor Driven Lathes consists of: ½ H.P. Reversing Motor (Westinghouse, General Electric or equal make), Reversing Switch (drum type), Wiring between Motor and Switch, Flexible Metal Conduit, Wiring Diagram and Leather Belt. For complete information on the Motor Drive Lathe see pages 28 and 29.

Easy Payment Prices of 11-inch x 4-foot Tool Room Quick Change Gear Precision Lathes

Lathe and Attachments	Countershaft Drive Lathe		Silent Chain Motor Drive Lathe			
	Catalog No. 884-A		Catalog No. 3884-A			
	Code Word	Price F.O.B. South Bend	Code Word	3 Phase 60 Cycle A.C. Motor	1 Phase 60 Cycle A.C. Motor	Direct Current Motor
11" x 4' Tool Room Quick Change Gear Precision Lathe (New Model) with Regular Equipment but without Tool Room Attachments.....	Emdor	\$359.00	Berow	\$498.00	\$526.00	\$509.00
TOOL ROOM ATTACHMENTS						
Hand Wheel Draw-In Collet Chuck with One Collet	Abode	38.00	Abode	38.00	38.00	38.00
Extra Collets ¼-inch up to ½-inch by 64ths. Each.	Cello	4.40	Cello	4.40	4.40	4.40
Taper Attachment	Devor	60.00	Devor	60.00	60.00	60.00
Thread Indicator	Acres	8.00	Acres	8.00	8.00	8.00
Oil Pan	Odlum	27.00	Odlum	27.00	27.00	27.00
Micrometer Carriage Stop	Cedex	12.00	Cedex	12.00	12.00	12.00
Collet Cabinet and Bracket	Crome	12.00	Crome	12.00	12.00	12.00
Prices of Tool Room Lathe Complete.....		\$520.40		\$659.40	\$687.40	\$670.40
Down Payment—20%		104.08		131.88	137.48	134.08
12 Equal Monthly Payments		36.43		46.16	48.12	46.93

Monthly Payments include carrying charge. Prices for longer or shorter bed lengths on request.

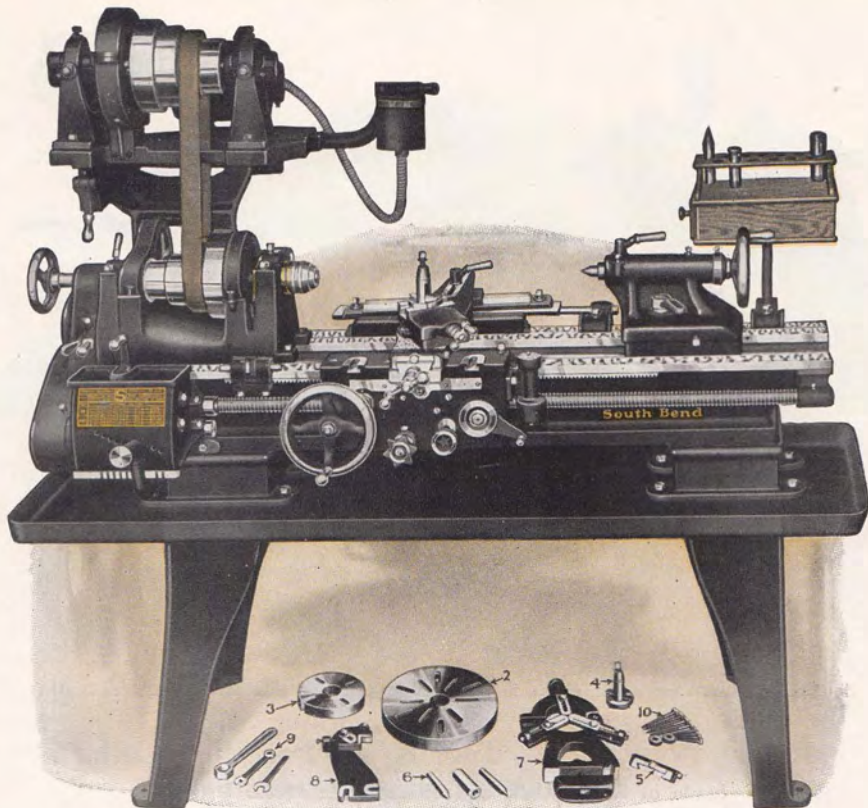

Equipment illustrated under Lathe is included in price of Silent Chain Motor Driven Lathes

13-inch New Model Tool Room Precision Lathe

Made in Countershaft and Silent Chain Motor Drives

The New Model South Bend Tool Room Precision Lathe is recommended for fine tool work. It is widely used by many of the largest manufacturing plants in the United States because it is capable of turning out fine tool work with precision and accuracy. This lathe is practical for making precision master taps, thread gauges, special screws, dies, fixtures, tools, etc. It will meet the demands of the expert mechanic on the most accurate work.

For Features, Specifications and detailed description applying to the 13-inch Tool Room Lathe see pages 7 to 9 and 14.

Tool Room Attachments are listed and priced separately so that the customer may select only those required for his work. All attachments are illustrated and described in this catalog.

Regular Equipment included with Lathes priced below consists of: Double Friction Countershaft (furnished with Countershaft Driven Lathes, only), Large Face Plate, Small Face Plate, Tool Post Complete, Adjustable Thread Cutting Stop, two Lathe Centers and Spindle Sleeve, Center Rest, Follower Rest and Wrenches. Also Installation Plans, Floor Plans and book, "How to Run a Lathe." See pages 52 and 53.

Electrical Equipment included in prices of Silent Chain Motor Driven Lathes consists of: 3/4 H.P. Reversing Motor (Westinghouse, General Electric or equal make), Reversing Switch (drum type), Wiring between Motor and Switch, Flexible Metal Conduit, Wiring Diagram and Leather Belt. For complete information on the Motor Drive Unit see pages 28 and 29.

Net Factory Prices of 13-inch x 5-foot Tool Room Quick Change Gear Precision Lathes

Lathe and Attachments	Silent Chain Motor Drive Lathe			Countershaft Drive Lathe		
	Catalog No. 3886-B			Catalog No. 886-B		
	Code Word	3 Phase 60 Cycle A.C. Motor	1 Phase 60 Cycle A.C. Motor	Direct Current Motor	Code Word	Price F. O. B. South Bend
13" x 5' Tool Room Quick Change Gear Precision Lathe (New Model) with Regular Equipment but without Tool Room Attachments.....	Gemic	\$602.00	\$645.00	\$613.00	Gehos	\$443.00
TOOL ROOM ATTACHMENTS						
Hand Wheel Draw-in Collet Chuck with One Collet..	About	44.00	44.00	44.00	About	44.00
Extra Collets 3/8-inch up to 1/2-inch by 64ths. Each.	Chose	5.00	5.00	5.00	Chose	5.00
Paper Attachment	Digit	75.00	75.00	75.00	Digit	75.00
Thread Indicator	Advis	10.00	10.00	10.00	Advis	10.00
Oil Pan	Ohern	38.00	38.00	38.00	Ohern	38.00
Micrometer Carriage Stop.....	Chain	13.00	13.00	13.00	Chain	13.00
Collet Cabinet and Bracket.....	Cnoke	12.00	12.00	12.00	Cnoke	12.00
Prices of Tool Room Lathe Complete		\$799.00	\$842.00	\$810.00		\$640.00
Down Payment—20%		15.90	168.40	162.00		128.00
12 Equal Monthly Payments.....		55.93	58.94	56.70		44.80

Monthly Payments include carrying charge.

Prices and Description of 15-inch Tool Room Lathe furnished on request.

SOUTH BEND, INDIANA, U. S. A.

Page 31

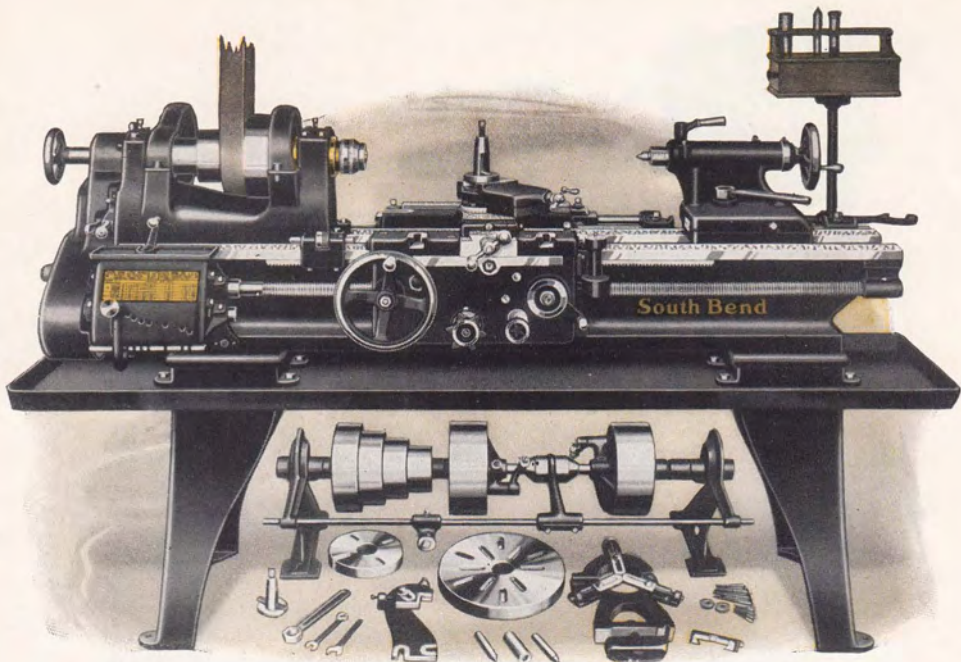

Equipment illustrated under Lathe is included in price of Countershaft Driven Lathe

16-inch New Model Tool Room Precision Lathe

Made in Countershaft and Silent Chain Motor Drives

The New Model South Bend Tool Room Precision Lathe is recommended for fine tool work. It is widely used by many of the largest manufacturing plants in the United States because it is capable of turning out fine tool work with precision and accuracy. This lathe is practical for making precision master taps, thread gauges, special screws, dies, fixtures, tools, etc. It will meet the demands of the expert mechanic on the most accurate work.

For Features, Specifications and detailed description applying to the 16-inch Tool Room Lathe see pages 2 to 9 and 18.

Tool Room Attachments are listed and priced separately so that the customer may select only those required for his work. All attachments are illustrated and described in this catalog.

Regular Equipment included with Lathes priced below consists of: Double Friction Countershaft (not furnished with Motor Driven Lathes), Large Face Plate, Small Face Plate, Tool Post Complete, Adjustable Thread Cutting Stop, two Lathe Centers and Spindle Sleeve, Center Rest, Follower Rest and Wrenches. Also Installation Plans, Floor Plans and book, "How to Run a Lathe." See pages 52 and 53.

Electrical Equipment included in prices of Silent Chain Motor Driven Lathes consists of: 1. H.P. Reversing Motor (Westinghouse, General Electric or equal make), Reversing Switch (drum type), Wiring between Motor and Switch, Flexible Metal Conduit, Wiring Diagram and Leather Belt. For complete information on the Motor Drive Lathe see pages 28 and 29.

Easy Payment Prices of 16-inch x 6-foot Tool Room Quick Change Gear Precision Lathes

Lathe and Attachments	Countershaft Drive Lathe		Silent Chain Motor Drive Lathe			
	Code Word	Price F.O.B. South Bend	Code Word	3 Phase 60 Cycle A.C. Motor	1 Phase 60 Cycle A.C. Motor	Direct Current Motor
16" x 6' Tool Room Quick Change Gear Precision Lathe (New Model) with Regular Equipment but without Tool Room Attachments.....	Malta	\$598.00	Madge	\$ 777.00	\$ 806.00	\$ 855.00
TOOL ROOM ATTACHMENTS						
Hand Wheel Draw-in Collet Chuck with One Collet	Adore	56.00	Adore	56.00	56.00	56.00
EXTRA Collets $\frac{3}{4}$ -inch up to $\frac{7}{8}$ -inch by 64ths. Each	Clear	6.00	Clear	6.00	6.00	6.00
Taper Attachment	Dress	90.00	Dress	90.00	90.00	90.00
Thread Indicator	Aflot	12.00	Aflot	12.00	12.00	12.00
Oil Pan	Okres	50.00	Okres	50.00	50.00	50.00
Micrometer Carriage Stop	Climb	15.00	Climb	15.00	15.00	15.00
Collet Cabinet and Bracket	Cadro	15.00	Cadro	15.00	15.00	15.00
Prices of Tool Room Lathe Complete*		\$842.00		\$1021.00	\$1050.00	\$1099.00
Down Payment—20%		168.40		204.20	210.00	219.80
12 Equal Monthly Payments		58.94		71.47	73.50	76.93

*For Price of Tool Room Lathe with 8 ft. bed add \$50.00.

Monthly Payments include carrying charge. Prices and description of 15-inch Tool Room Lathe on request.

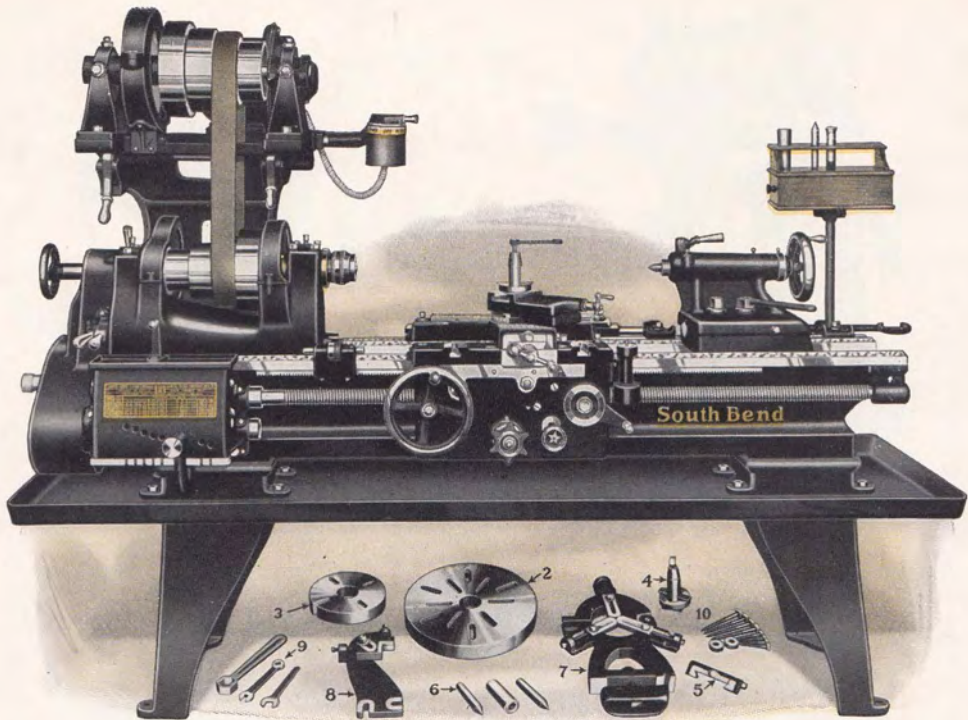

Equipment illustrated under Lathe is included in price of Silent Chain Motor Driven Lathe

18-inch New Model Tool Room Precision Lathe

Made in Countershaft and Silent Chain Motor Drives

The New Model South Bend Tool Room Precision Lathe is recommended for fine tool work. It is widely used by many of the largest manufacturing plants in the United States because it is capable of turning out fine tool work with precision and accuracy. This lathe is practical for making precision master taps, thread gauges, special screws, dies, fixtures, tools, etc. It will meet the demands of the expert mechanic on the most accurate work.

For Features, Specifications and detailed description applying to the 18-inch Tool Room Lathe see pages 2 to 9 and 20.

Tool Room Attachments are listed and priced separately so that the customer may select only those required for his work. All attachments are illustrated and described in this catalog.

Regular Equipment included with Lathes priced below consists of: Double Friction Countershaft (furnished with Countershaft Driven Lathes, only), Large Face Plate, Small Face Plate, Tool Post Complete, Adjustable Thread Cutting Stop, two Lathe Centers and Spindle Sleeve, Center Rest, Follower Rest and Wrenches. Also Installation Plans, Floor Plans and book, "How to Run a Lathe." See pages 52 and 53.

Electrical Equipment included in prices of Silent Chain Motor Driven Lathes consists of: 2 H.P. Reversing Motor (Westinghouse, General Electric or equal make), Reversing Switch (drum type), Wiring between Motor and Switch, Flexible Metal Conduit, Wiring Diagram and Leather Belt. For complete information on the Motor Drive Lathe see pages 28 and 29.

Easy Payment Prices of 18-inch x 8-foot Tool Room Quick Change Gear Precision Lathes

Lathe and Attachments	Silent Chain Motor Drive Lathe			Countershaft Drive Lathe	
	Code Word	3 Phase 60 Cycle A.C. Motor	1 Phase 60 Cycle A.C. Motor	Code Word	Price F.O.B. South Bend
18" x 8' Tool Room Quick Change Gear Precision Lathe (New Model) with Regular Equipment but without Tool Room Attachments.....	Semlin	\$ 997.00	\$1049.00	Sibar	\$ 763.00
TOOL ROOM ATTACHMENTS					
Hand Wheel Draw-in Collet Chuck with One Collet	Adult	63.00	63.00	Adult	63.00
Extra Collets 3/4-inch up to 1-inch by 64ths. Each..	Comet	6.50	6.50	Comet	6.50
Taper Attachment	Dunns	95.00	95.00	Dunns	95.00
Thread Indicator	Agrol	12.00	12.00	Agrol	12.00
Oil Pan	Omens	65.00	65.00	Omens	65.00
Micrometer Carriage Stop	Coral	17.00	17.00	Coral	17.00
Collet Cabinet and Bracket	Catch	15.00	15.00	Catch	15.00
Prices of Tool Room Lathe Complete.....		\$1270.50	\$1322.50		\$1036.50
Down Payment—20%		254.10	264.50		207.30
12 Equal Monthly Payments		88.94	92.58		72.56

Monthly Payments Include carrying charge. Prices for longer or shorter bed lengths on request.

SOUTH BEND, INDIANA, U. S. A.

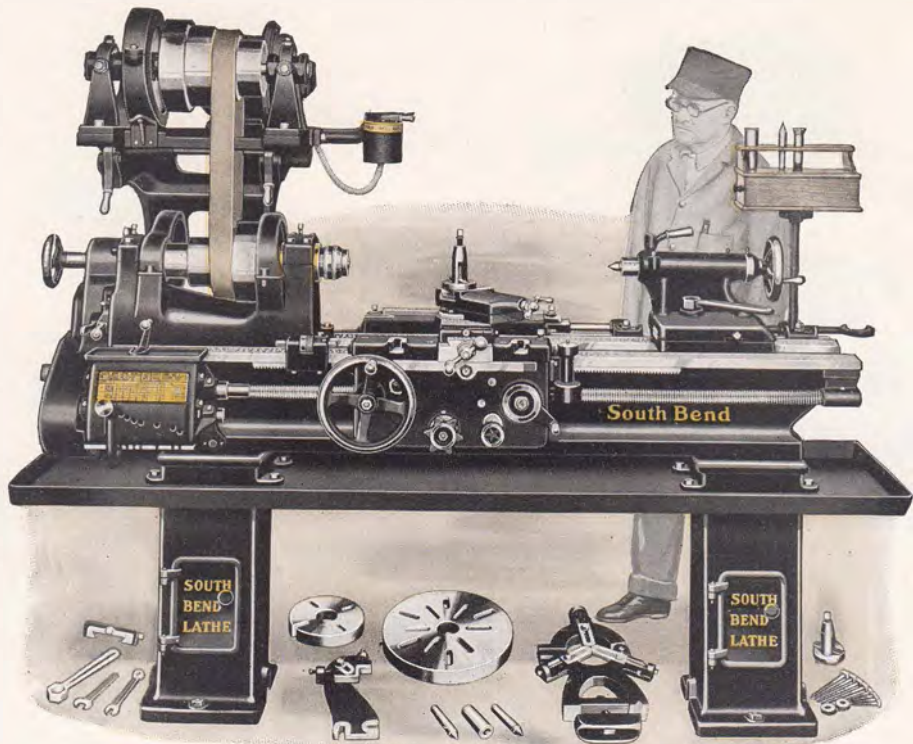

16-inch Motor Driven Tool Room Lathe Equipped with Cabinet Legs

Cabinet Legs—for South Bend Lathes with Oil Pan

9-inch to 18-inch Quick Change and Standard Change Gear Lathes

The Illustration Above shows a New Model Motor Driven Tool Room Precision Lathe with Oil Pan, fitted with Cabinet Legs instead of regular floor legs.

Cabinet Legs are so constructed that shelves may be arranged inside the legs (on all size Lathes except the 9-inch) for storing tools, attachments, wrenches, etc.

All Types of Oil Pan Lathes, Quick Change Gear and Standard Change Gear types, Overhead Countershaft Drive and Silent Chain Motor Drive

patterns, 9-inch to 18-inch, inclusive, can be supplied with Cabinet Legs instead of regular legs.

Any South Bend Lathe may be fitted with either one or two cabinet legs. Many mechanics prefer a Cabinet Leg under the head end of the lathe instead of the regular type leg. See illustration on next page.

Prices of Cabinet Legs are shown below. The tabulation lists the prices of one Cabinet Leg instead of the regular floor leg, also the prices of two Cabinet Legs instead of the regular type.

Net Factory Prices of Cabinet Legs Instead of Regular Floor Legs for Oil Pan Lathes

Size of Lathe	9-inch	11-inch	13-inch	15-inch	16-inch	18-inch
One Cabinet Leg instead of Regular Floor Leg. Price.....	\$10.00	\$11.00	\$13.00	\$15.00	\$16.00	\$18.00
Code Word	Pagan	Peter	Phile	Pints	Plead	Polar
Two Cabinet Legs instead of Regular Floor Legs. Price.....	\$20.00	\$22.00	\$26.00	\$30.00	\$32.00	\$36.00
Code Word	Padre	Pekoe	Pholk	Piles	Plank	Podge

Attachments for South Bend Lathes

South Bend Lathes may be fitted with all the attachments shown in this catalog. These equip the lathe for doing a wide variety of work. The attachments can be fitted at the time the lathe is purchased or attached after the lathe has been set up and in operation in industry.

Draw-in Collet Chucks
Spring Collets
Taper Attachments
Milling and Keyway Cutting Attachment
Turnstile Bed Turret
Centers, Drill Pads, etc.
Drill Chucks

South Bend Lathe Attachments are designed for use on South Bend Lathes only, and are not guaranteed to fit other makes of lathes. The vital dimensions of the different makes of lathes vary so that it is impossible to build South Bend Attachments for any other make of lathes.

Thread Indicator
Automatic Carriage Stop
Relieving Attachment
Carriage and Tool Post Turrets
Oil Pan and Pump
Electric Grinder
Lathe Chucks

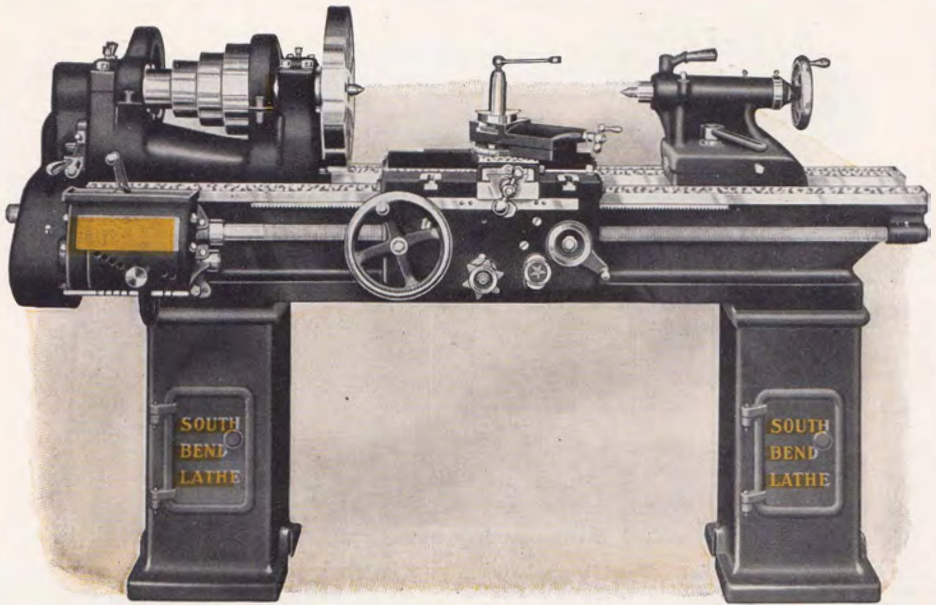

16-inch Lathe Equipped with Cabinet Legs

Cabinet Legs—for New Model South Bend Lathes

9-inch to 18-inch Quick Change and Standard Change Gear Lathes

The Illustration Above shows a New Model South Bend Quick Change Gear Lathe fitted with two Cabinet Legs instead of the regular floor legs.

Cabinet Legs are so constructed that shelves may be arranged inside the legs (on all size Lathes except the 9-inch) for storing tools, attachments, wrenches, etc.

All Types of Floor Leg Lathes, Quick Change Gear and Standard Change Gear types, Overhead Countershaft Drive and Silent Chain Motor Drive patterns, 9-inch to 18-inch lathes, inclusive, can be supplied with Cabinet Legs instead of regular legs at extra cost.

Any South Bend Lathe may be fitted with either one or two Cabinet Legs. Many mechanics prefer a Cabinet Leg under the head end of the lathe instead of the regular type leg. See illustration.

Prices of Cabinet Legs are shown below. The tabulation lists the prices of one Cabinet Leg instead of the regular floor leg, also the prices of two Cabinet Legs instead of the regular type.

The New Model South Bend Lathe can be fitted with a variety of attachments and used to advantage for many general shop and manufacturing operations. A complete line of attachments for all sizes and types of South Bend Lathes will be found in this catalog.

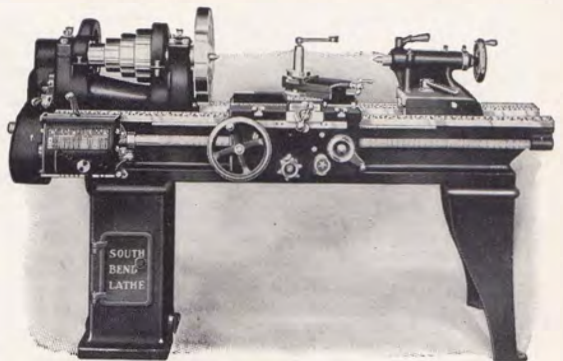

Lathe with Cabinet Leg and Regular Leg

Net Factory Prices of Cabinet Legs Instead of Regular Floor Legs

Size of Lathe	9-inch	11-inch	13-inch	15-inch	16-inch	18-inch
One Cabinet Leg instead of Regular Floor Leg. Price.....	\$10.00	\$11.00	\$13.00	\$15.00	\$16.00	\$18.00
Code Word	Pagan	Peter	Phile	Pints	Plead	Polar
Two Cabinet Legs instead of Regular Floor Legs. Price.....	\$20.00	\$22.00	\$26.00	\$30.00	\$32.00	\$36.00
Code Word	Padre	Pekoe	Pholk	Piles	Plank	Podge

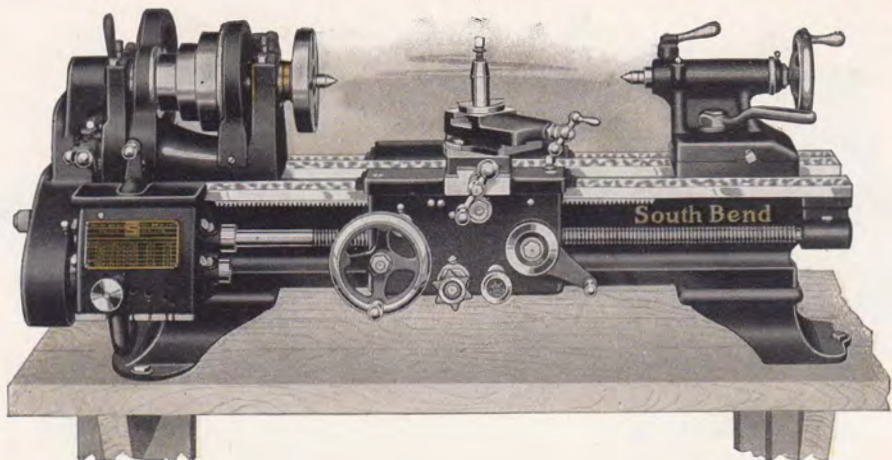

9-inch New Model South Bend Bench Lathes

Quick Change and Standard, Back Geared Screw Cutting Lathes—Countershaft Drive

The 9-inch New Model South Bend Bench Lathe shown above is an excellent tool for light work in the manufacturing plant and for the large scale production of small metal parts. It has precision and accuracy for fine tool work. Bench lathes of this type are often arranged in groups and handled by a single operator.

For Specifications and description of the 9-inch Bench Lathe, Quick Change Gear or Standard Change Gear types, refer to the 9-inch lathe with floor legs illustrated on pages 10 and 11 of this catalog. The only difference is that Bench Legs are substituted for Floor Legs.

The Headstock is back geared, reinforced and webbed, insuring strength and rigidity. Six spindle speeds are provided, three direct and three back geared. See page 6.

The New Apron has automatic cross and longitudinal turning feeds, and half nuts for thread cutting. An automatic safety interlock prevents the half nuts and automatic feeds from being engaged at the same time. See page 7.

The Gear Box on Quick Change Gear Lathes provides 48 changes for cutting screw threads, right or left, from 2 to 112 per inch. See page 5.

The Independent Change Gears supplied with Standard Change Gear Lathes permit cutting standard screw threads, right or left, from 4 to 40 per inch, including 1 1/2 pipe thread. See page 53.

The Hard Maple Bench is not included in the price of the Bench Lathe but can be furnished at extra cost. For prices and description of Bench see page 70.

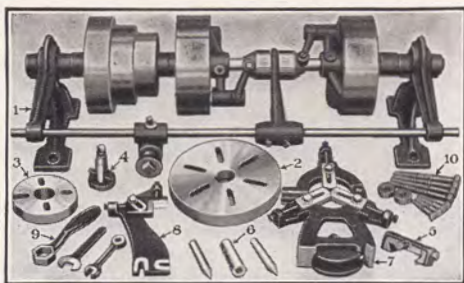

Equipment illustrated above is included in the price of the Lathe

The Regular Equipment included with each 9-inch Bench Lathe consists of: Double Friction Countershaft, Large and Small Face Plates, Tool Post Complete, Adjustable Thread Cutting Stop, two Lathe Centers and Spindle Sleeve, Center Rest, Follower Rest, Wrenches, a set of Independent Change Gears with Standard Change Gear Lathe, also Installation Plans and book "How to Run a Lathe." See pages 52 and 53.

Attachments. 9-inch Bench Lathes may be fitted with all the Attachments, Tools and Accessories that can be used on Floor Leg Lathes such as Draw-in Collet Chuck, Spring Collets, Taper Attachment, Milling and Keyway Cutting Attachment, Chucks, Turning and Boring Tools, etc.

Easy Payment Prices of 9-inch Bench Lathes Including Overhead Countershaft and Equipment

Catalog No. of Lathe	Swing Over Bed	Length of Bed	Between Centers	Hole Thru Spindle	Swing Over Carriage	Power Required	Weight Crated	Code Word	Price F.O.B. South Bend	Down Payment 20%	12 Equal Monthly Payments
9-inch Quick Change Gear Bench Lathes											
82-XB	9 1/4 in.	2 1/2 ft.	11 in.	3/4 in.	6 3/8 in.	1/4 H.P.	405 lbs.	Bamuz	\$278.00	\$55.60	\$19.46
82-YB	9 1/4 in.	3 ft.	18 in.	3/4 in.	6 3/8 in.	1/4 H.P.	425 lbs.	Belts	284.00	56.80	19.88
82-ZB	9 1/4 in.	3 1/2 ft.	23 in.	3/4 in.	6 3/8 in.	1/4 H.P.	445 lbs.	Bingo	290.00	58.00	20.30
82-AB	9 1/4 in.	4 ft.	29 in.	3/4 in.	6 3/8 in.	1/4 H.P.	465 lbs.	Blame	297.00	59.40	20.79
82-RB	9 1/4 in.	4 1/2 ft.	36 in.	3/4 in.	6 3/8 in.	1/4 H.P.	490 lbs.	Bodel	305.00	61.00	21.35
9-inch Standard Change Gear Bench Lathes											
31-XB	9 1/4 in.	2 1/2 ft.	11 in.	3/4 in.	6 3/8 in.	1/4 H.P.	395 lbs.	Bride	\$233.00	\$46.60	\$16.31
31-YB	9 1/4 in.	3 ft.	18 in.	3/4 in.	6 3/8 in.	1/4 H.P.	415 lbs.	Bulks	239.00	47.80	16.73
31-ZB	9 1/4 in.	3 1/2 ft.	23 in.	3/4 in.	6 3/8 in.	1/4 H.P.	435 lbs.	Bvork	245.00	49.00	17.15
31-AB	9 1/4 in.	4 ft.	29 in.	3/4 in.	6 3/8 in.	1/4 H.P.	455 lbs.	Bweir	252.00	50.40	17.64
31-RB	9 1/4 in.	4 1/2 ft.	36 in.	3/4 in.	6 3/8 in.	1/4 H.P.	480 lbs.	Bzone	260.00	52.00	18.20

Monthly Payments include carrying charge.

For End View of
Motor Drive Unit
See Page 44.

The 9-inch Lathe
Operates
from an
Electric Lamp
Socket.

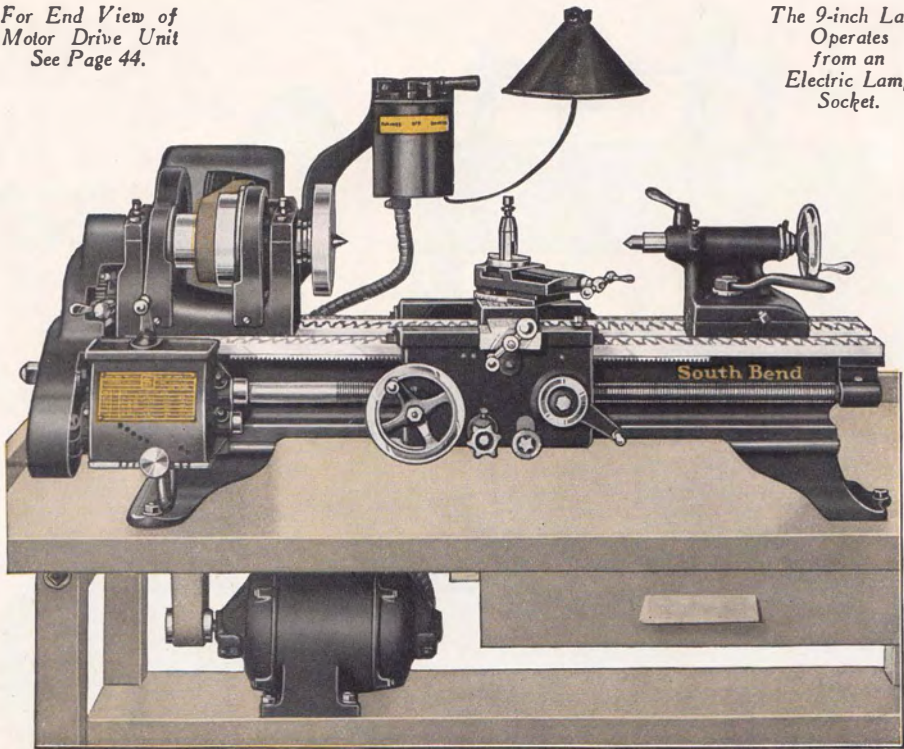

9-inch Horizontal Motor Driven Bench Lathes

Quick Change and Standard Change, Back Geared Screw Cutting Lathes

The 9-inch New Model South Bend Horizontal Motor Driven Bench Lathe is identically the same as the lathes illustrated and described on pages 10, 11 and 36 except that it has Bench Legs and is equipped with the Horizontal Motor Drive instead of countershaft drive. It will operate from an ordinary electric lamp socket at an average cost of about two cents per hour. This improved safety motor drive is efficient, powerful and noiseless in operation. The cabinet top opens to permit shifting of belt. Both the lathe and drive cabinet have three point bearing on the bench.

A $\frac{1}{4}$ Horsepower Reversing Motor placed on a shelf beneath the bench drives the jackshaft on which the drive pulley and countershaft cone are attached, all located within the cast iron cabinet. A reversing switch (Drum Type) is conveniently located so that the operator can start, stop or reverse the motor from an easy working position. The distance between center of jackshaft and the lathe spindle is 21 inches.

The Electrical Equipment included with the drive unit for this lathe consists of: $\frac{1}{4}$ H.P.; Constant Speed Reversing Motor, 1200 R.P.M.; Reversing Switch (Drum Type); Wiring between motor and switch; Flexible Metal Conduit; Wiring Diagram; two Leather Belts; Cast Iron Cabinet with Drive Mechanism.

Specifications of Electric Current to be used should be given when ordering. See page 29.

The Lathe Equipment included in the price of each 9-inch Horizontal Motor Driven Bench Lathe consists of: Large and Small Face Plates, Tool Post Complete, Adjustable Thread Cutting Stop, two Lathe Centers and Spindle Sleeve, Center Rest, Follower Rest, Wrenches and Independent Change Gears with Standard Change Gear Lathes, also Installation Plans, Floor Plans and book, "How to Run a Lathe." See page 53.

The Hard Maple Bench is not included in the price of the lathe but is extra. See page 70.

Easy Payment Prices, 9-inch Horizontal Motor Driven Bench Lathe

Prices Include Lathe, Drive Cabinet, Lathe Equipment, Reversing Motor, Reversing Switch, Two Belts. But Not Bench

Swing Over Bed	Length of Bed	Size of Motor	Approx. Weight Crated	Catalog Number of Lathe	With 3 Phase—60 Cycle A. C. Motor			With 1 Phase—60 Cycle A. C. Motor			With Direct Current Motor		
					Price F.O.B. S. Bend	Down Payment 20%	12 Equal Monthly Payments	Price F.O.B. S. Bend	Down Payment 20%	12 Equal Monthly Payments	Price F.O.B. S. Bend	Down Payment 20%	12 Equal Monthly Payments
9-inch Quick Change Gear Horizontal Motor Driven Bench Lathe													
9/4 in.	2 1/2 ft.	1/4 H.P.	490 lbs.	482-X	\$348.00	\$69.60	\$24.36	\$363.00	\$72.60	\$25.41	\$356.00	\$71.20	\$24.92
9/4 in.	3 ft.	1/4 H.P.	510 lbs.	482-Y	354.00	70.80	24.78	369.00	73.80	25.83	362.00	72.40	25.34
9/4 in.	3 1/2 ft.	1/4 H.P.	530 lbs.	482-Z	360.00	72.00	25.20	375.00	75.00	26.25	368.00	73.60	25.76
9/4 in.	4 ft.	1/4 H.P.	530 lbs.	482-A	367.00	73.40	25.69	382.00	76.40	26.74	375.00	75.00	26.25
9/4 in.	4 1/2 ft.	1/4 H.P.	575 lbs.	482-R	375.00	75.00	26.25	390.00	78.00	27.30	383.00	76.60	26.81
9-inch Standard Change Gear Horizontal Motor Driven Bench Lathe													
9/4 in.	2 1/2 ft.	1/4 H.P.	480 lbs.	431-X	\$303.00	\$60.60	\$21.21	\$318.00	\$63.60	\$22.26	\$311.00	\$62.20	\$21.77
9/4 in.	3 ft.	1/4 H.P.	500 lbs.	431-Y	309.00	61.80	21.63	324.00	64.80	22.68	317.00	63.40	22.19
9/4 in.	3 1/2 ft.	1/4 H.P.	520 lbs.	431-Z	315.00	63.00	22.05	330.00	66.00	23.10	323.00	64.60	22.61
9/4 in.	4 ft.	1/4 H.P.	540 lbs.	431-A	322.00	64.40	22.54	337.00	67.40	23.59	330.00	66.00	23.10
9/4 in.	4 1/2 ft.	1/4 H.P.	565 lbs.	431-R	330.00	66.00	23.10	345.00	69.00	24.15	338.00	67.60	23.66

Monthly Payments include carrying charge. This Lathe is also furnished in 11-inch swing, prices on request.

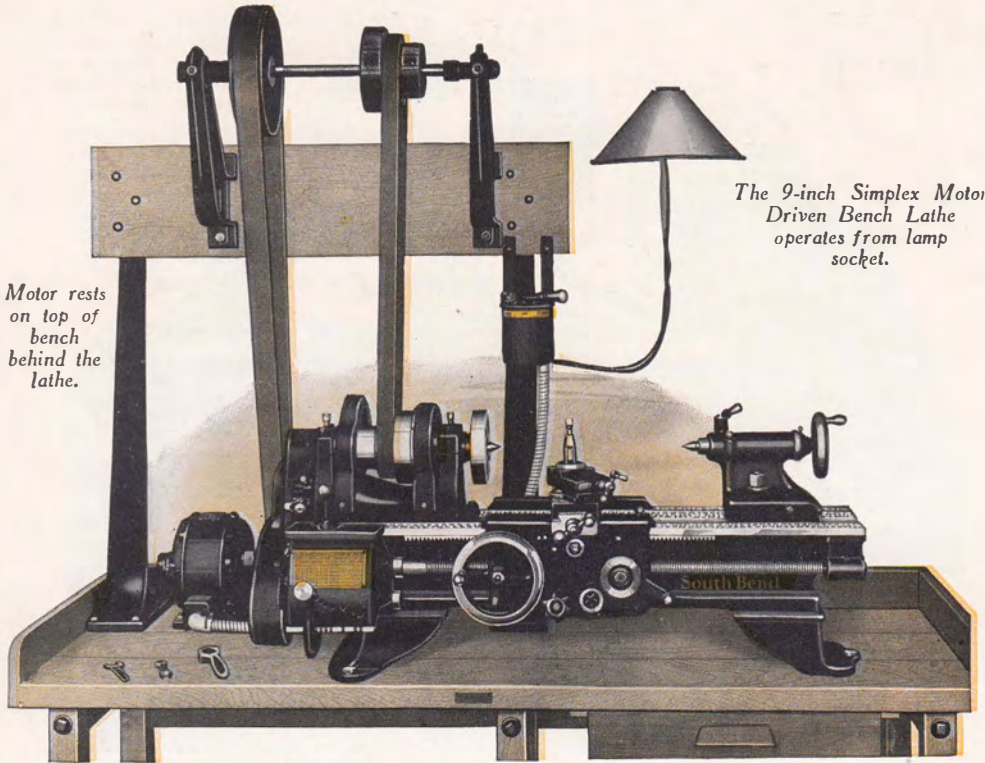

Motor rests on top of bench behind the lathe.

The 9-inch Simplex Motor Driven Bench Lathe operates from lamp socket.

9-inch Simplex Motor Driven Bench Lathes

Quick Change and Standard Change, Back Geared, Screw Cutting Lathes

The 9-inch New Model South Bend Simplex Motor Driven Bench Lathe is practical for general machine shop work and precision tool work. A reversing motor is mounted on the bench and drives the Simplex countershaft which is supported overhead by metal countershaft standards. Starting, stopping and reversing of the direction of the lathe spindle is controlled by a drum type reversing switch within easy reach of the operator.

For Specifications and Description of the 9-inch Bench Lathe refer to page 36, as the only difference between the Simplex Motor Driven Bench Lathe and the Overhead Countershaft Driven Lathe is the form of drive.

A 1/4-horsepower Reversing Motor driven from an ordinary lamp socket gives sufficient power to operate the 9-inch Simplex Motor Driven Bench Lathe at maximum capacity for an average cost of about two cents per hour.

Electrical Equipment included in the price of each 9-inch Simplex Motor Driven Bench Lathe consists of a 1/4 H. P. Reversing Motor 1200 R. P. M. (Westinghouse, General Electric or equal make), Reversing Switch (Drum Type), Wiring between motor and switch, Flexible Metal Conduit, Wiring Diagram and two Leather Belts. See page 29 for information on ordering.

Regular Lathe Equipment included in the price of each 9-inch Simplex Motor Driven Bench Lathe consists of: Simplex Countershaft, Large and Small Face Plates, Tool Post Complete, Adjustable Thread Cutting Stop, two Lathe Centers and Spindle Sleeve, Center Rest, Follower Rest, Wrenches, Independent Change Gears with Standard Change Gear Lathes. Also Installation Plans, Floor Plans and book, "How to Run a Lathe." See page 53.

The Hard Maple Wooden Bench and Countershaft Standards are not included in the price of the Lathe, but are extra. See page 70.

Easy Payment Prices 9-inch Simplex Motor Driven Bench Lathe

Prices Include Simplex Countershaft, Lathe Equipment, Reversing Motor and Switch, Two Belts. But Not Bench or Standards

Swing Over Bed	Length of Bed	Size of Motor	Approx. Weight Crated	Catalog Number of Lathe	Code Word	With 3 Phase—60 Cycle A. C. Motor			With 1 Phase—60 Cycle A. C. Motor			With Direct Current Motor		
						Price F.O.B. S. Bend	Down Payment 20%	12 Equal Monthly Payments	Price F.O.B. S. Bend	Down Payment 20%	12 Equal Monthly Payments	Price F.O.B. S. Bend	Down Payment 20%	12 Equal Monthly Payments
9-inch Quick Change Gear Simplex Motor Driven Bench Lathe														
9 1/4 in.	2 1/2 ft.	1/4 H.P.	505 lbs.	582-XB	Radet	\$336.00	\$67.20	\$23.52	\$351.00	\$70.20	\$24.57	\$344.00	\$68.80	\$24.08
9 1/4 in.	3 ft.	1/4 H.P.	525 lbs.	582-YB	Beard	342.00	68.40	23.94	357.00	71.40	24.99	350.00	70.00	24.50
9 1/4 in.	3 1/2 ft.	1/4 H.P.	545 lbs.	582-ZB	Bilet	348.00	69.60	24.36	363.00	72.60	25.41	356.00	71.20	24.92
9 1/4 in.	4 ft.	1/4 H.P.	565 lbs.	582-AB	Block	355.00	71.00	24.85	370.00	74.00	25.90	363.00	72.60	25.41
9 1/4 in.	4 1/2 ft.	1/4 H.P.	590 lbs.	582-RB	Bobin	363.00	72.60	25.41	378.00	75.60	26.46	371.00	74.20	25.97
9-inch Standard Change Gear Simplex Motor Driven Bench Lathe														
9 1/4 in.	2 1/2 ft.	1/4 H.P.	495 lbs.	531-NB	Brute	\$291.00	\$58.20	20.37	\$306.00	\$61.20	\$21.42	\$299.00	\$59.80	\$20.93
9 1/4 in.	3 ft.	1/4 H.P.	515 lbs.	531-YB	Buted	297.00	59.40	20.79	312.00	62.40	21.84	305.00	61.00	21.35
9 1/4 in.	3 1/2 ft.	1/4 H.P.	535 lbs.	531-ZB	Evans	303.00	60.60	21.21	318.00	63.60	22.26	311.00	62.20	21.77
9 1/4 in.	4 ft.	1/4 H.P.	555 lbs.	531-AB	Bwast	310.00	62.00	21.70	325.00	65.00	22.75	318.00	63.60	22.26
9 1/4 in.	4 1/2 ft.	1/4 H.P.	580 lbs.	531-RB	Bzard	318.00	63.60	22.26	333.00	66.60	23.31	326.00	65.20	22.82

Monthly Payments include carrying charge.

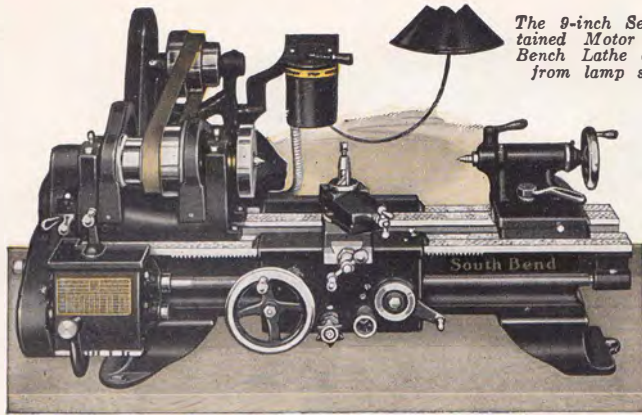

The 9-inch Self-Contained Motor Driven Bench Lathe operates from lamp socket.



End View of Drive Unit
Part of Gear Guard Removed
to Show the Chain

9-inch Self-Contained Motor Driven Bench Lathes

Quick Change and Standard Change, Back Geared, Screw Cutting Lathes

The 9-inch Self-Contained Motor Driven Bench Lathe is practical for general light work in the machine shop and for fine precision tool and instrument work. When this unit is mounted on a bench and connected to a lamp socket, it is ready for operation.

For Specifications and Description of the 9-inch Bench Lathe, refer to page 36, as the only difference between the 9-inch Self-Contained Bench Lathe and the Overhead Countershaft Driven Lathe is the form of drive.

Operates from Lamp Socket. A ¼-horsepower reversing motor connected to an ordinary lamp socket gives sufficient power to operate the 9-inch Self-Contained Motor Driven Bench Lathe at maximum capacity. Operating cost averages two cents per hour.

The Reversing Switch (Drum Type) is conveniently located so that the operator can start, stop or reverse the motor from an easy working position in front of the lathe. The switch has three positions: Left for forward motion of the lathe spindle; center for stop, and right for reverse.

Use Code Word. When ordering a Self-Contained Motor Driven Bench Lathe, use Code Words listed below to indicate the size of Self-Contained Motor Driven Bench Lathe wanted. Use Code Words shown on page 29 to indicate motor specifications.

When Ordering a Self-Contained Motor Driven Bench Lathe, be sure to specify the electric current being used. If alternating current, state exact voltage, phase, cycle and number of wires. If direct current, state exact voltage. When giving voltage of motor, state whether 110-volt motor or 220-volt motor is wanted. Do not specify 110-220-volt motor, as we cannot furnish motors for double voltage rating.

Electrical Equipment included in the price of each Self-Contained Motor Driven Bench Lathe consists of: ¼ H. P. Reversing Motor 1200 R. P. M., (Westinghouse, General Electric or equal make), Reversing Switch (Drum Type), Wiring between motor and switch, Flexible Metal Conduit, Wiring Diagram and a Leather Belt.

Regular Lathe Equipment included in the price of each Self-Contained Motor Driven Bench Lathe consists of: Large and Small Face Plates, Tool Post Complete, Adjustable Thread Cutting Stop, Two Lathe Centers and Spindle Sleeve, Center Rest, Follower Rest, Wrenches, and Independent Change Gears with Standard Change Gear Lathes. Also Installation Plans, Floor Plans and book, "How to Run a Lathe." See page 53.

The Hard Maple Wooden Bench illustrated above is not included in the price of the Self-Contained Motor Driven Bench Lathe but can be furnished at extra cost. For prices and descriptions of this bench, see page 70.

Easy Payment Prices 9-inch New Model South Bend Self-Contained Motor Driven Bench Lathes

Prices Include Lathe Equipment, Reversing Motor, Reversing Switch and Leather Belt, But Do Not Include Bench

Swing Over Bed	Length of Bed	Size of Motor	Approx. Weight Crated	Catalog No. of Lathe	Code Word	With 3 Phase, 60 Cycle A. C. Motor			With 1 Phase, 60 Cycle A. C. Motor			With Direct Current Motor		
						Price F.O.B. South Bend	Down Payment 20%	12 Equal Monthly Payments	Price F.O.B. South Bend	Down Payment 20%	12 Equal Monthly Payments	Price F.O.B. South Bend	Down Payment 20%	12 Equal Monthly Payments
9-inch Quick Change Gear Self-Contained Motor Driven Bench Lathe														
9 1/4 in.	2 1/2 ft.	1/4 H.P.	490 lbs.	782-X	Baern	\$360.00	\$72.00	\$25.20	\$375.00	\$75.00	\$26.25	\$368.00	\$73.60	\$25.76
9 1/4 in.	3 ft.	1/4 H.P.	520 lbs.	782-Y	Beatr	366.00	73.20	25.62	381.00	76.20	26.67	374.00	74.80	26.18
9 1/4 in.	3 1/2 ft.	1/4 H.P.	550 lbs.	782-Z	Bidos	372.00	74.40	26.04	387.00	77.40	27.09	380.00	76.00	26.60
9 1/4 in.	4 ft.	1/4 H.P.	580 lbs.	782-A	Blota	379.00	75.80	26.53	394.00	78.80	27.58	387.00	77.40	27.09
9 1/4 in.	4 1/2 ft.	1/4 H.P.	610 lbs.	782-R	Bosni	387.00	77.40	27.09	402.00	80.40	28.14	395.00	79.00	27.65
9-inch Standard Change Gear Self-Contained Motor Driven Bench Lathe														
9 1/4 in.	2 1/2 ft.	1/4 H.P.	480 lbs.	731-X	Braid	\$315.00	\$63.00	\$22.05	\$330.00	\$66.00	\$23.10	\$323.00	\$64.60	\$22.61
9 1/4 in.	3 ft.	1/4 H.P.	510 lbs.	731-Y	Bunko	321.00	64.20	22.47	336.00	67.20	23.52	329.00	65.80	23.03
9 1/4 in.	3 1/2 ft.	1/4 H.P.	540 lbs.	731-Z	Bvail	327.00	65.40	22.89	342.00	68.40	23.94	335.00	67.00	23.45
9 1/4 in.	4 ft.	1/4 H.P.	570 lbs.	731-A	Bwops	334.00	66.80	23.38	349.00	69.80	24.43	342.00	68.40	23.94
9 1/4 in.	4 1/2 ft.	1/4 H.P.	600 lbs.	731-R	Bzairp	342.00	68.40	23.94	357.00	71.40	24.99	350.00	70.00	24.50

Monthly Payments include carrying charge.

SOUTH BEND, INDIANA, U. S. A.

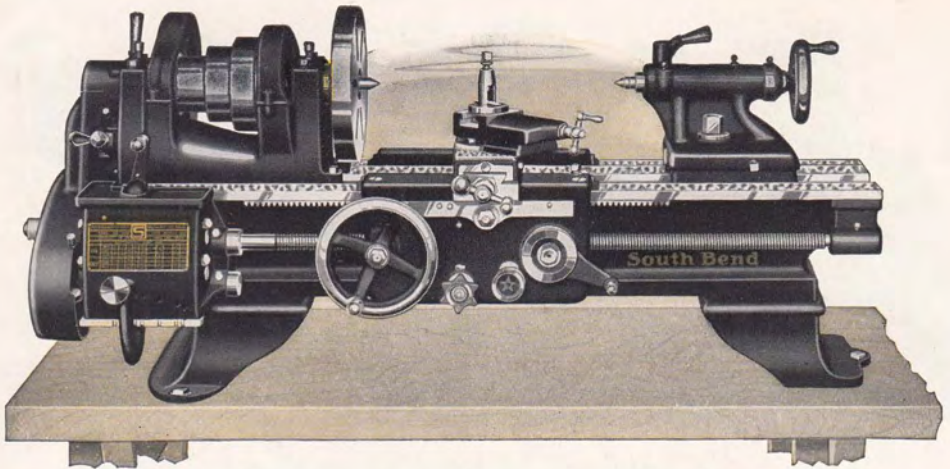

11-inch New Model South Bend Bench Lathes

Quick Change and Standard, Back Geared Screw Cutting Lathes—Countershaft Drive

The 11-inch New Model South Bend Bench Lathe shown above is an excellent tool for light work in the manufacturing plant and for the large scale production of small metal parts. It has precision and accuracy for fine tool work. Bench lathes of this type are often arranged in groups and handled by a single operator.

For Specifications and description of the 11-inch Bench Lathe, Quick Change Gear or Standard Change Gear types, refer to the 11-inch lathe with floor legs illustrated on pages 12 and 13 of this catalog. The only difference is that Bench Legs are substituted for Floor Legs.

The Headstock is back geared, reinforced and webbed, insuring strength and rigidity. Six spindle speeds are provided, three direct and three back geared. See page 6.

The New Apron has automatic cross and longitudinal turning feeds, and half nuts for thread cutting. An automatic safety interlock prevents the half nuts and automatic feeds from being engaged at the same time. See page 7.

The Gear Box on Quick Change Gear Lathes provides 48 changes for cutting screw threads, right or left, from 2 to 112 per inch. See page 5.

The Independent Change Gears supplied with Standard Change Gear Lathes permit cutting standard screw threads, right or left, from 4 to 40 per inch, including 1 1/2 pipe thread. See page 53.

The Hard Maple Bench is not included in the price of the Bench Lathe but can be furnished at extra cost. For prices and description of Bench see page 70.

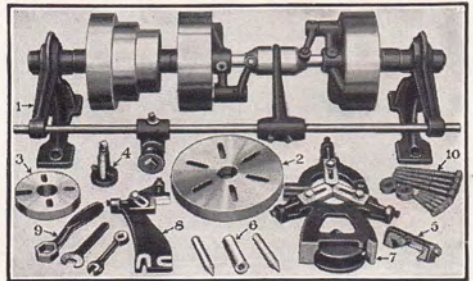

Equipment illustrated above is included in the price of the Lathe

The Regular Equipment included with each 11-inch Bench Lathe consists of: Double Friction Countershaft, Large and Small Face Plates, Tool Post Complete, Adjustable Thread Cutting Stop, two Lathe Centers and Spindle Sleeve, Center Rest, Follower Rest, Wrenches, a set of Independent Change Gears with Standard Change Gear Lathe, also Installation Plans and book "How to Run a Lathe." See pages 52 and 53.

Attachments. 11-inch Bench Lathes may be fitted with all the Attachments, Tools and Accessories that can be used on Floor Leg Lathes such as Draw-in Collet Chuck, Spring Collets, Taper Attachment, Milling and Keyway Cutting Attachment, Chucks, Turning and Boring Tools, etc.

Easy Payment Prices of 11-inch Bench Lathes Including Overhead Countershaft and Equipment

Catalog No. of Lathe	Swing Over Bed	Length of Bed	Between Centers	Hole Thru Spindle	Swing Over Carriage	Power Required	Weight Crated	Code Word	Price F.O.B. South Bend	Down Payment 20%	12 Equal Monthly Payments
11-inch Quick Change Gear Bench Lathes											
84-YB	1 1/4 in.	3 ft.	12 in.	7/8 in.	7 5/8 in.	1/2 H.P.	575 lbs.	Ebony	\$335.00	\$67.00	\$23.45
84-ZB	1 1/4 in.	3 1/2 ft.	18 in.	7/8 in.	7 5/8 in.	1/2 H.P.	600 lbs.	Echos	342.00	68.40	23.94
84-AB	1 1/4 in.	4 ft.	24 in.	7/8 in.	7 5/8 in.	1/2 H.P.	625 lbs.	Edwin	349.00	69.80	24.43
84-BB	1 1/4 in.	5 ft.	36 in.	7/8 in.	7 5/8 in.	1/2 H.P.	705 lbs.	Efort	365.00	73.00	25.55
84-SB	1 1/4 in.	5 1/2 ft.	42 in.	7/8 in.	7 5/8 in.	1/2 H.P.	745 lbs.	Egapsu	374.00	74.80	26.18
11-inch Standard Change Gear Bench Lathes											
33-YB	1 1/4 in.	3 ft.	12 in.	7/8 in.	7 5/8 in.	1/2 H.P.	560 lbs.	Egast	\$285.00	\$57.00	\$19.95
33-ZB	1 1/4 in.	3 1/2 ft.	18 in.	7/8 in.	7 5/8 in.	1/2 H.P.	585 lbs.	Ejorn	292.00	58.40	20.44
33-AB	1 1/4 in.	4 ft.	24 in.	7/8 in.	7 5/8 in.	1/2 H.P.	610 lbs.	Elong	299.00	59.80	20.93
33-BB	1 1/4 in.	5 ft.	36 in.	7/8 in.	7 5/8 in.	1/2 H.P.	690 lbs.	Emate	315.00	63.00	22.05
33-SB	1 1/4 in.	5 1/2 ft.	42 in.	7/8 in.	7 5/8 in.	1/2 H.P.	730 lbs.	Enbuf	324.00	64.80	22.68

Monthly Payments include carrying charge.

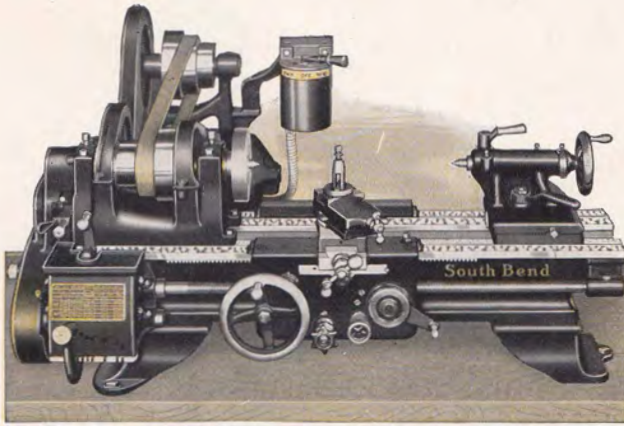

End View of Drive Unit
Part of Gear Guard Removed
to Show the Chain

11-inch Self-Contained Motor Driven Bench Lathes

Quick Change and Standard Change, Back Geared, Screw Cutting Lathes

The 11-inch Self-Contained Motor Driven Bench Lathe is practical for general light work in the machine shop and for fine precision tool and instrument work. When this unit is mounted on a bench and connected to the electric current, it is ready for operation.

For Specifications and Description of the 11-inch Bench Lathe, refer to page 40, as the only difference between the 11-inch Self-Contained Bench Lathe and the Overhead Countershaft Driven Lathe is the form of drive.

The Reversing Switch (Drum Type) is conveniently located so that the operator can start, stop or reverse the motor from an easy working position in front of the lathe. The switch has three positions: Left for forward motion of the lathe spindle; center for stop, and right for reverse.

When Ordering a Self-Contained Motor Driven Bench Lathe, be sure to specify the electric current being used. If alternating current, state exact voltage, phase, cycle and number of wires. If direct current, state exact voltage. When giving voltage of motor, state whether 110-volt motor or 220-volt motor is wanted. Do not specify 110-220-volt motor, as we cannot furnish motors for double voltage rating.

Use Code Words listed below to indicate the size of Lathe wanted. Use Code Words shown on page 29 to indicate motor specifications.

Electrical Equipment included in the price of each Self-Contained Motor Driven Bench Lathe consists of: 1/2 H. P. Reversing Motor 1200 R. P. M., (Westinghouse, General Electric or equal make), Reversing Switch (Drum Type), Wiring between motor and switch, Flexible Metal Conduit, Wiring Diagram and a Leather Belt.

Regular Lathe Equipment included in the price of each Self-Contained Motor Driven Bench Lathe consists of: Large and Small Face Plates, Tool Post Complete, Adjustable Thread Cutting Stop, Two Lathe Centers and Spindle Sleeve, Center Rest, Follower Rest, Wrenches, and Independent Change Gears with Standard Change Gear Lathes. Also Installation Plans, Floor Plans and book, "How to Run a Lathe." See page 53.

The Lathe is Thoroughly Tested before shipping. We connect the motor and switch, test and inspect the wiring, then inspect the lathe while operating under its own power.

Attachments. This Lathe may be fitted with all the Attachments, Tools and Accessories that can be used on Floor Leg Lathes such as Draw-in Collet Chuck, Spring Collets, Taper Attachment, Milling and Keyway Cutting Attachment, Chucks, Turning and Boring Tools, etc.

The Hard Maple Wooden Bench illustrated above is not included in the price of the Self-Contained Motor Driven Bench Lathe but can be furnished at extra cost. For prices and descriptions of this bench, see page 70.

Easy Payment Prices 11-inch New Model South Bend Self-Contained Motor Driven Bench Lathe

Prices Include Lathe Equipment, Reversing Motor, Reversing Switch and Leather Belt, But Do Not Include Bench

Swing Over Bed	Length of Bed	Size of Motor	Approx. Weight Crated	Catalog Number of Lathe	With 3 Phase—60 Cycle A. C. Motor			With 1 Phase—60 Cycle A. C. Motor			With Direct Current Motor		
					Price F. O. B. South Bend	Down Payment 20%	12 Equal Monthly Payments	Price F. O. B. South Bend	Down Payment 20%	12 Equal Monthly Payments	Price F. O. B. South Bend	Down Payment 20%	12 Equal Monthly Payments
11-inch Quick Change Gear Self-Contained Motor Driven Bench Lathe													
1 1/4 in.	3 ft.	1/2 H.P.	640 lbs.	784-Y	\$446.00	\$89.20	\$31.22	\$474.00	\$ 94.80	\$33.18	\$457.00	\$91.40	\$31.99
1 1/4 in.	3 1/2 ft.	1/2 H.P.	670 lbs.	784-Z	453.00	90.60	31.71	481.00	96.20	33.67	464.00	92.80	32.48
1 1/4 in.	4 ft.	1/2 H.P.	700 lbs.	784-A	460.00	92.00	32.20	488.00	97.60	34.16	471.00	94.20	32.97
1 1/4 in.	5 ft.	1/2 H.P.	730 lbs.	784-B	476.00	95.20	33.32	504.00	100.80	35.28	487.00	97.40	34.09
1 1/4 in.	5 1/2 ft.	1/2 H.P.	760 lbs.	784-S	485.00	97.00	33.95	513.00	102.60	35.91	496.00	99.20	34.72
11-inch Standard Change Gear Self-Contained Motor Driven Bench Lathe													
1 1/4 in.	3 ft.	1/2 H.P.	625 lbs.	733-Y	\$396.00	\$79.20	\$27.72	\$424.00	\$ 84.80	\$29.68	\$407.00	\$81.40	\$28.49
1 1/4 in.	3 1/2 ft.	1/2 H.P.	655 lbs.	733-Z	403.00	80.60	28.21	431.00	86.20	30.17	414.00	82.80	28.98
1 1/4 in.	4 ft.	1/2 H.P.	685 lbs.	733-A	410.00	82.00	28.70	438.00	87.60	30.66	421.00	84.20	29.47
1 1/4 in.	5 ft.	1/2 H.P.	715 lbs.	733-B	426.00	85.20	29.82	445.00	89.00	31.15	437.00	87.40	30.59
1 1/4 in.	5 1/2 ft.	1/2 H.P.	745 lbs.	733-S	435.00	87.00	30.45	463.00	92.60	32.41	446.00	89.20	31.22

Monthly Payments include carrying charge.

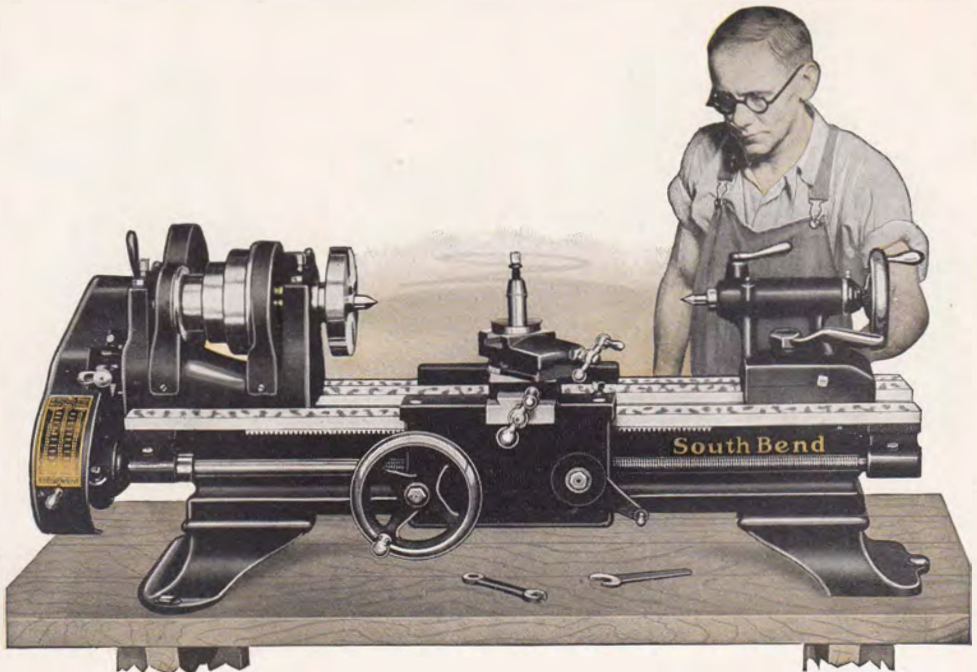

9-inch Junior New Model South Bend Bench Lathe

Back Geared Screw Cutting Precision Lathe—Countershaft Drive

The 9-inch Junior Back Geared Screw Cutting Lathe is assembled from the units of the regular 9-inch Standard Change Gear Lathe that we have been making for twenty-three years. The headstock, tailstock, bed and saddle are identical on these two lathes. Also the same accuracy and precision, hand scraping and inspection that our regular lathes receive is given to the 9-inch Junior Lathe.

Using the Regular Units of the 9-inch Standard Change Gear Lathe and omitting the friction Automatic Longitudinal Feed, Automatic Cross Feed and Friction Clutch from the apron, and the Large Face Plate, Follower Rest, Center Rest, and Thread Cutting Stop from the equipment (parts which are not always necessary for the work in the small shop), makes it possible for us to set a price as low as \$163.00 on the 9-inch Junior Lathe.

For Features of the 9-inch Junior New Model South Bend Lathe refer to page 43 as the only difference between this lathe and the 9-inch Junior Floor Leg Lathe illustrated and described on page 43 is in the type of legs.

LATHE FEATURES

Back geared headstock gives six spindle speeds. Hollow spindle made of special carbon steel. Phosphor bronze bearings for spindle. Graduated compound rest swivels to any angle. Precision lead screw for cutting accurate threads. Micrometer collar on cross feed and compound rest screws. Tailstock set-over for turning and boring tapers. Quick-acting spring latch reverses carriage travel. Power longitudinal screw feed to the carriage. Graduated tailstock spindle.

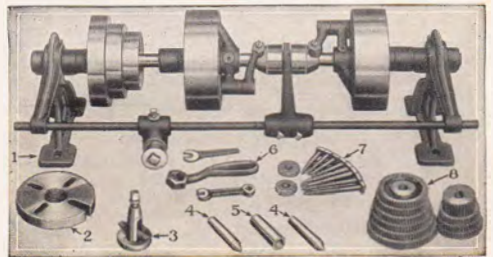

The Lathe Equipment included in the price of each 9-inch New Model Junior Bench Lathe consists of: Double Friction Countershaft, Face Plate, Tool Post Complete, two Lathe Centers, Spindle Sleeve, Wrenches, Lag Screws and Washers, and a set of Change Gears, as illustrated above, for thread cutting and turning feeds. Also Installation Plans and book, "How to Run a Lathe."

LATHE SPECIFICATIONS

Countershaft Speed.....300 R.P.M.
Spindle Speeds.....40, 75, 128, 246, 410, 700 R.P.M.
Width of Cone Pulley Belt.....1 inch
Acme Thread Lead Screw..... $\frac{3}{4}$ -inch diam., 8 pitch
Size of Lathe Centers.....No. 2 Morse Taper
Screw Thread Cutting Range..... $\frac{1}{4}$ to 40 per inch
Draw-in Collet Chuck Capacity..... $\frac{1}{2}$ inch to $\frac{1}{2}$ inch
Cross Slide Travel..... $\frac{1}{2}$ inch x 7 inches
Size of Tool Shank for Tool Post..... $\frac{1}{2}$ inch x $\frac{1}{2}$ inch
Double Friction Countershaft Pulleys... $6\frac{1}{2}$ inch x 2 $\frac{1}{8}$ inch

Easy Payment Prices of 9-inch Junior New Model Bench Lathe, Including Countershaft and Equipment*

Catalog No. of Lathe	Swing Over Bed	Length of Bed	Between Centers	Hole Thru Spindle	Swing Over Carriage	Power Required	Weight Crated	Code Word	Price F.O.B. South Bend	Down Payment 20%	12 Equal Monthly Payments
22-XB	9 $\frac{1}{4}$ in.	2 $\frac{1}{2}$ ft.	11 in.	$\frac{3}{4}$ in.	6 $\frac{3}{4}$ in.	$\frac{1}{4}$ H.P.	350 lbs.	Bxlow	\$163.00	\$32.60	\$11.41
22-YB	9 $\frac{1}{4}$ in.	3 ft.	18 in.	$\frac{3}{4}$ in.	6 $\frac{3}{4}$ in.	$\frac{1}{4}$ H.P.	375 lbs.	Bhorn	169.00	33.80	11.83
22-ZB	9 $\frac{1}{4}$ in.	3 $\frac{1}{2}$ ft.	23 in.	$\frac{3}{4}$ in.	6 $\frac{3}{4}$ in.	$\frac{1}{4}$ H.P.	400 lbs.	Bmatx	175.00	35.00	12.25
22-AB	9 $\frac{1}{4}$ in.	4 ft.	28 in.	$\frac{3}{4}$ in.	6 $\frac{3}{4}$ in.	$\frac{1}{4}$ H.P.	425 lbs.	Blear	182.00	36.40	12.74
22-RB	9 $\frac{1}{4}$ in.	4 $\frac{1}{2}$ ft.	36 in.	$\frac{3}{4}$ in.	6 $\frac{3}{4}$ in.	$\frac{1}{4}$ H.P.	450 lbs.	Broil	190.00	38.00	13.30

*Prices do not include Bench, see page 70. If Countershaft is not wanted deduct \$12.00 from above prices. Monthly Payments include carrying charge.

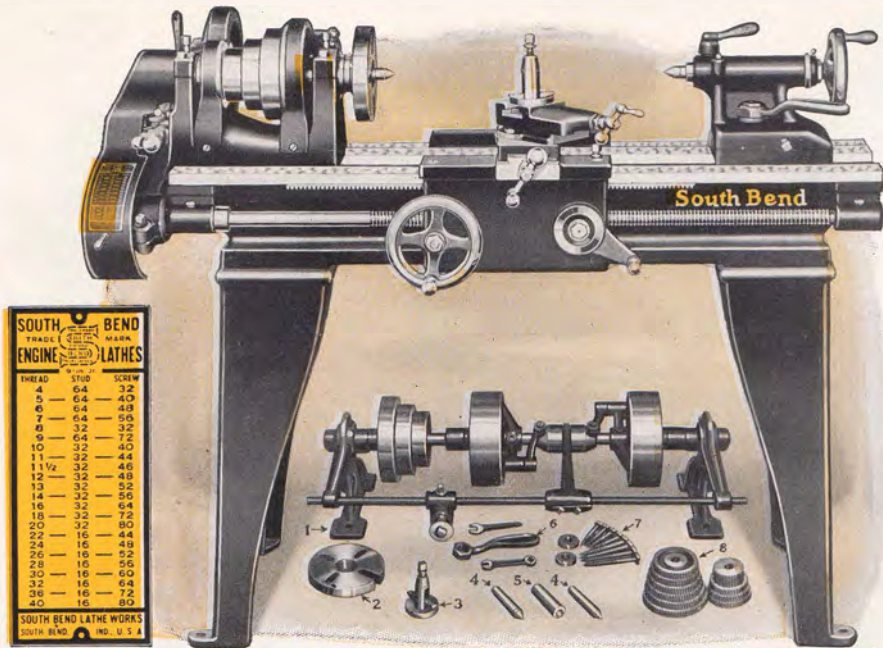

THREAD	STUD	SCREW
4	64	32
5	64	40
6	64	48
7	64	56
8	32	32
9	64	72
10	32	60
11	32	44
11 1/2	32	48
12	32	48
13	32	52
14	32	56
16	32	64
18	32	72
20	32	80
22	16	44
24	16	48
26	16	52
30	16	60
32	16	64
36	16	72
40	16	80

SOUTH BEND LATHES WORKS
SOUTH BEND, IND. U. S. A.

Index Plate Regular equipment illustrated above is included in price of Lathe

9-inch Junior New Model South Bend Lathe

Back Geared, Screw Cutting Precision Lathe (Floor Legs), Countershaft Drive

The 9-inch Junior New Model South Bend Back Geared Screw Cutting Precision Lathe is practical for fine precision work in the manufacturing plant, tool room, laboratory, experimental shop and engineering shop. It has power, accuracy, and precision and will take care of the machining of all kinds of metals, such as steel, cast iron, wrought iron, forgings, brass, bronze, copper, aluminum, babbitt, etc., also for working of wood and compositions, such as hard rubber, fibre, etc.

The No. 22 Junior 9-inch Back Geared Screw Cutting Lathe is assembled from the units of our regular No. 31—9-inch Standard Change Gear Lathe that we have been making for twenty-three years—the same Headstock, Tailstock, Bed and Saddle—all are identical on the No. 22 Lathe with those of the No. 31 Lathe. The same accuracy and precision, hand scraping and inspection that our regular Lathes receive is also given to the No. 22 Lathe.

Features of the 9-inch Junior Lathe

Back Geared Headstock with 3-step Cone provides 7 spindle speeds—three direct, for machining light work, and 3 back geared for heavy work, including chucking, etc. See page 6.

Ground Headstock Spindle is made of special carbon steel and can be fitted with 6-inch Chuck. Has 3/4-inch hole its entire length for machining long bars and rods. See page 8.

Phosphor Bronze Spindle Bearings for Head Spindle are hand scraped to perfect bearing, are adjustable for wear and are equipped with Patent Oilers. See page 8.

Compound Rest is graduated 180 degrees and can be clamped at any angle. Feed Screw has Micrometer collar. See page 6.

Precision Lead Screw is 3/4-inch in diameter, has 8 threads per inch, Acme Standard, cut on a machine equipped with a Master Lead Screw, which insures accuracy. See page 7.

Automatic Longitudinal Screw Feed. The No. 22—9-inch Lathe is fitted with automatic longitudinal screw feed to the carriage by clamping the half nut on the lead screw. Various cutting feeds, fine or coarse, may be obtained through the gears furnished with the lathe.

Cutting Screw Threads. An Index Plate is attached to each 9-inch Junior Lathe and shows the proper change gears to use to cut the following standard screw threads per inch, right or left: 4, 5, 6, 7, 8, 9, 10, 11, 11 1/2, 12, 13, 14, 16, 18, 20, 22, 24, 26, 28, 30, 32, 36 and 40. (See Index Plate illustrated above.)

The Countershaft and Equipment included with each 9-inch Junior New Model Lathe consists of: Double Friction Countershaft, Face Plate, Tool Post Complete, Two Lathe Centers, Spindle Sleeve, Wrenches, Lag Screws and Washers and Change Gears for feeds and thread cutting. (Equipment is illustrated under lathe.)

SPECIFICATIONS OF THE 9-INCH JUNIOR LATHE

Screw Thread Cutting Range.....	4 to 40 per inch
Precision Acme Lead Screw.....	3/4 in. diam., 8 Threads
Head and Tail Spindle Centers.....	No. 2, Morse Taper
Size of Spindle Nose.....	1 1/2 in. diam., 8 Threads
Size of Hole through Spindle.....	3/4 in.
Width of Cone Pulley Belt.....	1 in.
Spindle Speeds.....	40, 75, 128, 246, 410, 700 R.P.M.
Countershaft Speed.....	300 R.P.M.
Countershaft Friction Clutch Pulleys.....	6 7/8 in. x 2 1/8 in.
Size of Lathe Tool Shank.....	3/8 in. x 7/8 in.

Easy Payment Prices of 9-inch Junior Lathe (Floor Leg Type), Including Countershaft and Equipment

Catalog No. of Lathe	Swing Over Bed	Length of Bed	Between Centers	Hole Thru Spindle	Swing Over Carriage	Power Required	Weight Crated	Code Word	Price F.O.B. S. Bend	Down Payment 20%	12 Equal Monthly Payments
22-X	9 1/4 in.	2 1/2 ft.	11 in.	3/4 in.	6 3/4 in.	1/4 H.P.	415 lbs.	Byrto	\$173.00	\$34.60	\$12.11
22-Y	9 1/4 in.	3 ft.	18 in.	3/4 in.	6 3/4 in.	1/4 H.P.	440 lbs.	Bhunt	179.00	35.80	12.53
22-Z	9 1/4 in.	3 1/2 ft.	23 in.	3/4 in.	6 3/4 in.	1/4 H.P.	465 lbs.	Bmeio	185.00	37.00	12.95
22-A	9 1/4 in.	4 ft.	29 in.	3/4 in.	6 3/4 in.	1/4 H.P.	490 lbs.	Blunt	192.00	38.40	13.44
22-R	9 1/4 in.	4 1/2 ft.	36 in.	3/4 in.	6 3/4 in.	1/4 H.P.	515 lbs.	Bryan	200.00	40.00	14.00

Monthly Payments include carrying charge.

SOUTH BEND, INDIANA, U. S. A.



Cabinet Top Open Showing Drive Pulley



Phantom View of Motor Drive Unit

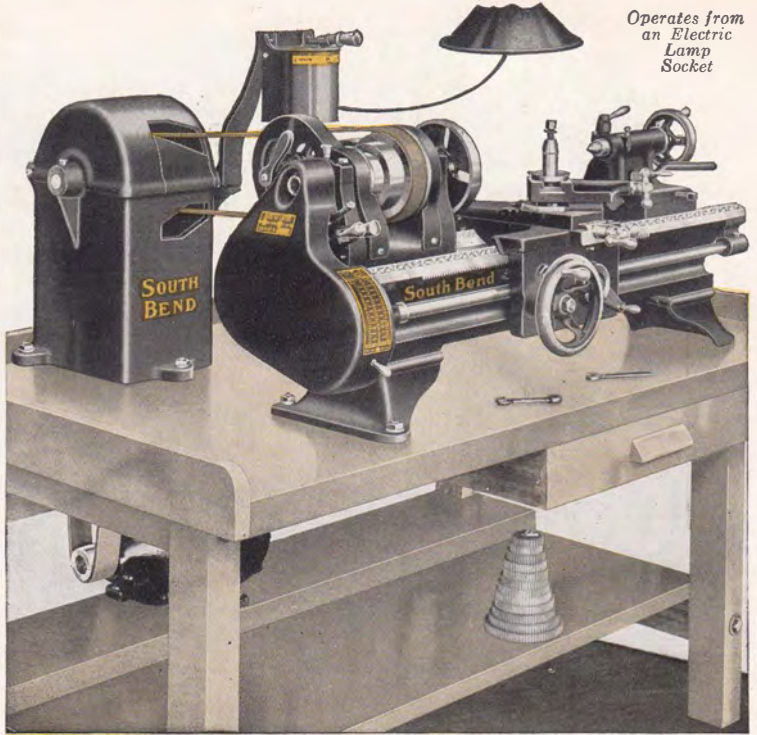

Operates from an Electric Lamp Socket

9-inch Junior New Model Horizontal Motor Driven Lathe

Back Geared, Screw Cutting Precision Tool, Bench Type

The 9-inch Junior New Model South Bend Horizontal Motor Driven Lathe, Bench Type, is identically the same as the 9-inch Junior Bench Lathe illustrated and described on pages 42 and 43, except that it is equipped with the Horizontal Motor Drive, instead of the countershaft drive. It will operate from an ordinary electric lamp socket at an average cost of about 2 cents per hour. This is an improved and efficient safety motor drive that is noiseless and powerful in operation. The cabinet top opens to permit shifting the belt. Both the lathe and drive cabinet have three point bearing on the bench.

A $\frac{1}{4}$ -horsepower Reversing Motor placed on a shelf beneath the bench drives the jackshaft on which the drive pulley and countershaft cone are attached, all located within the cast iron cabinet. A $\frac{1}{4}$ -inch leather belt connects the motor with the drive pulley. A 1-inch leather belt from the countershaft cone drives the lathe spindle cone. Distance between center of jackshaft and lathe spindle 21 inches.

A Reversing Switch (Drum Type) conveniently located within easy reach of the operator, controls the motor and provides instantaneous starting, stopping and reversing of the lathe spindle. The switch has three positions: Left for forward motion of the lathe spindle; Center for stop; and Right for reverse.

The Electrical Equipment included with the drive unit for this lathe consists of: $\frac{1}{4}$ H. P. Constant Speed Reversing Motor, 1200 R. P. M.; Reversing Switch (Drum Type); Wiring between Motor and Switch; Flexible Metal Conduit; Wiring Diagram; two Leather Belts; Cast Iron Cabinet with Drive Mechanism.

The Lathe Equipment included in the price consists of: Face Plate, Tool Post Complete, two Lathe Centers and Spindle Sleeve, Wrenches, Independent Change Gears, Bolts, Nuts and Washers. Also Installation Plans and book, "How to Run a Lathe."

Electric Current Specifications should be given when ordering. If alternating current, state exact voltage, phase, cycle and number of wires. If direct current, state exact voltage only. Specify whether 110 or 220-volt motor is wanted as we cannot furnish motors of double rating.

The Lathe is Thoroughly Tested before shipping. We connect the motor and switch, test and inspect the wiring, then inspect the lathe while operating under its own power.

The Hard Maple Wooden Bench illustrated above is not included in the price of the 9-inch Junior Horizontal Motor Driven Lathe, but can be furnished at extra cost. For price and description see page 70.

Easy Payment Prices 9-inch Junior Horizontal Motor Driven Lathe—Without Bench

Prices Include Lathe, Drive Cabinet, Lathe Equipment, Reversing Motor, Reversing Switch, Two Belts, But Not Bench

Catalog No. of Lathe	Swing Over Bed	Length of Bed	Size of Motor	Weight Crated	Code Word	With 3 Phase, 60 Cycle A. C. Motor			With 1 Phase, 60 Cycle A. C. Motor			With Direct Current Motor		
						Price F.O.B. South Bend	Down Payment 20%	12 Equal Monthly Payments	Price F.O.B. South Bend	Down Payment 20%	12 Equal Monthly Payments	Price F.O.B. South Bend	Down Payment 20%	12 Equal Monthly Payments
422-X	9 $\frac{1}{2}$ in.	2 $\frac{1}{2}$ ft.	$\frac{1}{4}$ H.P.	435 lbs.	Badly	\$233.00	\$46.60	\$16.31	\$248.00	\$49.60	\$17.36	\$241.00	\$48.20	\$16.87
422-Y	9 $\frac{1}{2}$ in.	3 ft.	$\frac{1}{4}$ H.P.	465 lbs.	Bijou	239.00	47.80	16.73	254.00	50.80	17.78	247.00	49.40	17.29
422-Z	9 $\frac{1}{2}$ in.	3 $\frac{1}{2}$ ft.	$\frac{1}{4}$ H.P.	495 lbs.	Borax	243.00	49.00	17.15	260.00	52.00	18.20	253.00	50.60	17.71
422-A	9 $\frac{1}{2}$ in.	4 ft.	$\frac{1}{4}$ H.P.	525 lbs.	Bunco	252.00	50.40	17.64	267.00	53.40	18.69	260.00	52.00	18.20
422-R	9 $\frac{1}{2}$ in.	4 $\frac{1}{2}$ ft.	$\frac{1}{4}$ H.P.	555 lbs.	Brawl	260.00	52.00	18.20	275.00	55.00	19.25	268.00	53.60	18.76

Monthly Payments include carrying charge.

Operates from
Lamp Socket

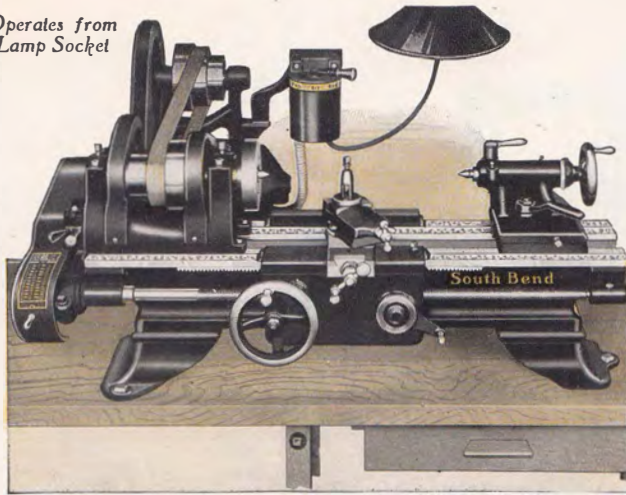

The 9-inch Junior Self-Contained Motor Driven Bench Lathe



End View of Drive Unit
Gear Guard Removed

The Self-Contained Motor Drive Unit illustrated above is placed directly behind the lathe. The motor rests on a base and drives the counter-shaft cone through a silent chain and sprocket which gives a noiseless, efficient drive. The spindle cone is driven by a leather belt.

9-inch Junior Self-Contained Motor Driven Bench Lathe

Back Geared, Screw Cutting Precision Lathe (New Model)

The Self-Contained Motor Driven Junior Bench Lathe is practical for general work in the machine shop and for fine precision tool and instrument work. When this unit is mounted on a bench and connected to the current, it is ready for operation.

For Specifications and Descriptions of the 9-inch Junior Bench Lathes, refer to pages 42 and 43, as the only difference between the 9-inch Junior Self-Contained Motor Driven Bench Lathe and the Overhead Countershaft Driven Lathe is the form of drive.

Operates from Lamp Socket. A $\frac{1}{4}$ -horsepower Reversing Motor driven from an ordinary lamp socket gives sufficient power to operate the 9-inch Junior Self-Contained Motor Driven Bench Lathe at maximum capacity. Operating cost averages two cents per hour.

The Reversing Switch (Drum Type) is conveniently located so that the operator can start, stop or reverse the motor from an easy working position in front of the lathe. The switch has three positions: Left for forward motion of the lathe spindle, center for stop, and right for reverse.

Use Code Word. When ordering a 9-inch Junior Self-Contained Motor Driven Bench Lathe, use Code Words listed below to indicate the size of Self-Contained Motor Driven Bench Lathe wanted. Use Code words shown on page 29 to indicate motor specifications.

You Can Secure your current specifications from the electric power company furnishing your current.

The Lathe Is Thoroughly Tested. Before shipping, the motor, switch and wiring are inspected and tested and the lathe operated under its own power.

When Ordering a 9-inch Self-Contained Motor Driven Bench Lathe, be sure to specify the electric current. If alternating current, state exact voltage, phase, cycle and number of wires. If direct current, state exact voltage. When giving voltage of motor, state whether 110-volt motor or 220-volt motor is wanted. Do not specify 110-220-volt motor, as we cannot furnish motors for double voltage rating.

Electrical Equipment included in the price of each 9-inch Junior Self-Contained Motor Driven Bench Lathe consists of a $\frac{1}{4}$ horsepower Reversing Motor 1200 R.P.M., (Westinghouse, General Electric or equal make), Reversing Switch (Drum Type), wiring between motor and switch, Flexible Metal Conduit, Wiring Diagram, and a Leather Belt. For complete information see page 29.

Lathe Equipment included in the price of each 9-inch Junior Self-Contained Motor Driven Bench Lathe consists of: Face Plate, Tool Post Complete, Two Lathe Centers and Spindle Sleeve, Change Gears for thread cutting, Lag Screws, Washers and Wrenches. Prices do not include maple bench, information on which will be found on page 70.

The Hard Maple Wooden Bench illustrated above is not included in the price of the 9-inch Junior Self-Contained Motor Driven Bench Lathe but can be furnished at extra cost. For prices and descriptions of this bench, see page 70.

Easy Payment Prices 9-inch Junior Self-Contained Motor Driven Bench Lathe

Prices Include Lathe Equipment, Reversing Motor, Reversing Switch and Leather Belt, But Do Not Include Bench

Catalog No. of Lathe	Swing Over Bed	Length of Bed	Size of Motor	Weight Crated	Code Word	With 3 Phase, 60 Cycle A. C. Motor			With 1 Phase, 60 Cycle A. C. Motor			With Direct Current Motor		
						Price F. O. B. South Bend	Down Payment 20%	12 Equal Monthly Payments	Price F. O. B. South Bend	Down Payment 20%	12 Equal Monthly Payments	Price F. O. B. South Bend	Down Payment 20%	12 Equal Monthly Payments
722-X	9 $\frac{1}{4}$ in.	2 $\frac{3}{4}$ ft.	$\frac{1}{4}$ H.P.	410 lbs.	Barbe	\$245.00	\$49.00	\$17.15	\$260.00	\$52.00	\$18.20	\$253.00	\$50.60	\$17.71
722-Y	9 $\frac{1}{4}$ in.	3 ft.	$\frac{1}{4}$ H.P.	470 lbs.	Bezor	251.00	50.20	17.57	266.00	53.20	18.62	259.00	51.80	18.13
722-Z	9 $\frac{1}{4}$ in.	3 $\frac{1}{2}$ ft.	$\frac{1}{4}$ H.P.	500 lbs.	Boalt	257.00	51.40	17.99	272.00	54.40	19.04	265.00	53.00	18.55
722-A	9 $\frac{1}{4}$ in.	4 ft.	$\frac{1}{4}$ H.P.	530 lbs.	Blase	264.00	52.80	18.48	279.00	55.80	19.53	272.00	54.40	19.04
722-B	9 $\frac{1}{4}$ in.	4 $\frac{1}{2}$ ft.	$\frac{1}{4}$ H.P.	560 lbs.	Buble	272.00	54.40	19.04	287.00	57.40	20.09	280.00	56.00	19.60

Monthly Payments include carrying charge.

SOUTH BEND, INDIANA, U. S. A.

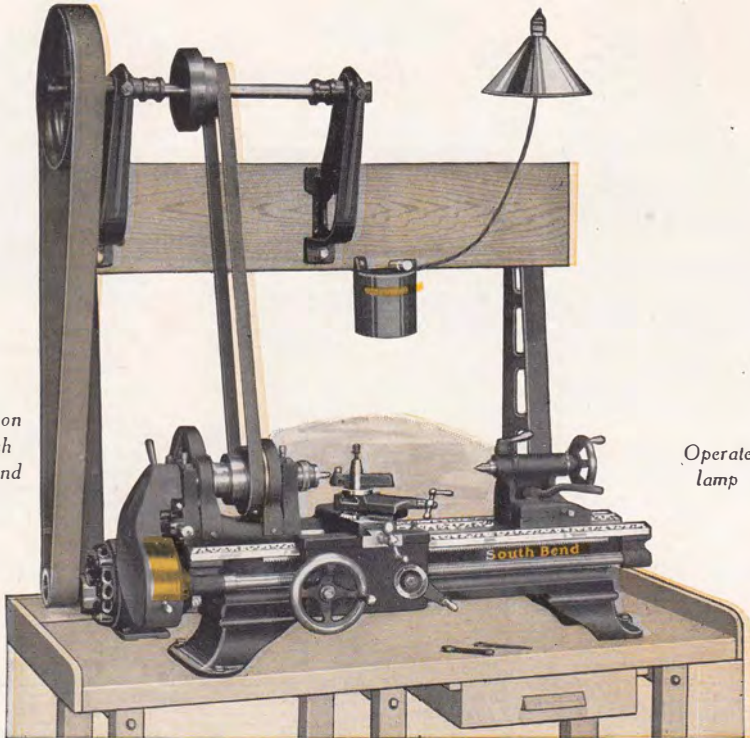

Motor rests on top of bench directly behind the lathe

Operates from lamp socket

9-inch Junior Simplex Motor Driven Bench Lathe Back Geared, Screw Cutting Precision Lathe (New Model)

The Simplex Motor Drive is a very practical method for driving a precision bench lathe used for general machine and tool work. The drive is noiseless and efficient in operation and makes a very complete and serviceable unit.

For Specifications and Descriptions of the 9-inch Junior Bench Lathes, refer to pages 42 and 43, as the only difference between the 9-inch Junior Simplex Motor Driven Bench Lathe and the Overhead Countershaft Driven Lathe is the form of drive.

Operates from Lamp Socket. A $\frac{1}{4}$ horsepower reversing motor driven from an ordinary lamp socket gives sufficient power to operate the 9-inch Junior Simplex Motor Driven Bench Lathe at maximum capacity. Operating cost averages two cents per hour.

The Reversing Switch (Drum Type) is conveniently located so that the operator can start, stop or reverse the motor from an easy working position in front of the lathe. The switch has three positions: Left for forward motion of the lathe spindle; center for stop, and right for reverse.

When Ordering a 9-inch Simplex Motor Driven Bench Lathe, be sure to specify the electric current. If alternating current, state exact voltage, phase, cycle and number of wires. If direct current, state exact voltage. When giving voltage of motor, state whether 110-volt motor or 220-volt motor is wanted. Do not specify 110-220-volt motor, as we cannot furnish motors for double voltage rating.

Electrical Equipment included in the price of each 9-inch Junior Simplex Motor Driven Bench Lathe consists of a $\frac{1}{4}$ -horsepower Reversing Motor 1200 R.P.M. (Westinghouse, General Electric or equal make), Reversing Switch (Drum Type), wiring between motor and switch, Flexible Metal Conduit, Wiring Diagram, and two Leather Belts.

Lathe Equipment included in the price of each 9-inch Junior Simplex Motor Driven Bench Lathe consists of: Simplex Countershaft, Face Plate, Tool Post Complete, Two Lathe Centers and Spindle Sleeve, Change Gears for thread cutting, Lag Screws, Washers and Wrenches. Prices do not include maple bench or standards, information on which will be found on page 70.

Easy Payment Prices 9-inch Junior Simplex Motor Driven Bench Lathe—Without Bench or Standards Prices Include Simplex Countershaft, Lathe Equipment, Reversing Motor and Switch, Two Belts, But Not Bench or Standards

Catalog No. of Lathe	Swing Over Bed	Length of Bed	Size of Motor	Weight Crated	Code Word	With 3 Phase, 60 Cycle A. C. Motor			With 1 Phase, 60 Cycle A. C. Motor			With Direct Current Motor		
						Price F.O.B. South Bend	Down Payment 20%	12 Equal Monthly Payments	Price F.O.B. South Bend	Down Payment 20%	12 Equal Monthly Payments	Price F.O.B. South Bend	Down Payment 20%	12 Equal Monthly Payments
522-XB	9 $\frac{1}{4}$ in.	2 $\frac{1}{2}$ ft.	$\frac{1}{4}$ H.P.	460 lbs.	Baxor	\$221.00	\$44.20	\$15.47	\$236.00	\$47.20	\$16.52	\$229.00	\$45.80	\$16.03
522-YB	9 $\frac{1}{4}$ in.	3 $\frac{1}{2}$ ft.	$\frac{1}{4}$ H.P.	475 lbs.	Behra	227.00	45.40	15.89	242.00	48.40	16.94	235.00	47.00	16.45
522-ZB	9 $\frac{1}{4}$ in.	3 $\frac{3}{4}$ ft.	$\frac{1}{4}$ H.P.	495 lbs.	Boflu	233.00	46.60	16.31	248.00	49.60	17.36	241.00	48.20	16.87
522-AB	9 $\frac{1}{4}$ in.	4 ft.	$\frac{1}{4}$ H.P.	515 lbs.	Bimle	240.00	48.00	16.80	255.00	51.00	17.85	248.00	49.60	17.36
522-RB	9 $\frac{1}{4}$ in.	4 $\frac{1}{4}$ ft.	$\frac{1}{4}$ H.P.	535 lbs.	Bugle	248.00	49.60	17.36	263.00	52.60	18.41	256.00	51.20	17.92

For prices on Simplex Bench Lathe with wall-type countershaft as shown above, but without reversing motor, reversing switch, wiring, flexible conduit, and leather belt, refer to prices on page 42. Monthly Payments include carrying charge.

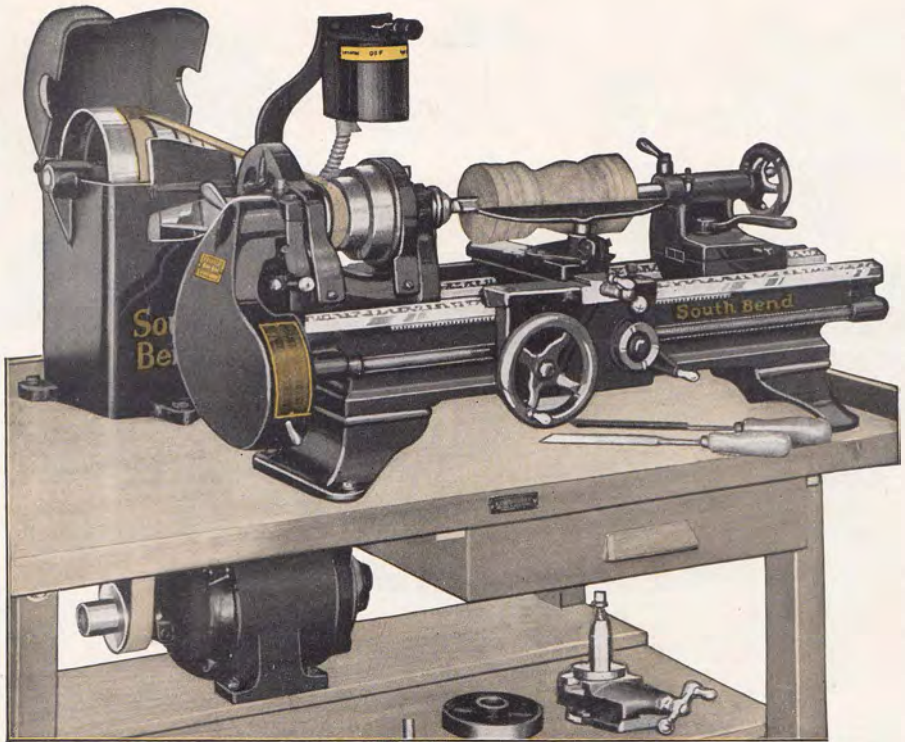

9-inch Junior Combination Metal and Wood Working Lathe

Back Gearing, Screw Cutting Precision Tool, Bench Type, Horizontal Motor Drive

The 9-inch Junior Combination Metal and Wood Working Lathe is shown above in horizontal motor drive type with bench legs. It is a practical tool for machining metal of all kinds and for wood working. This lathe is widely used for fine precision work and in the manufacturing plant, pattern shop, wood shop, and laboratory.

A $\frac{1}{2}$ -horsepower Reversing Motor operates the lathe at maximum capacity. This motor has a 2-step drive pulley—the small step permitting a low range of speeds for machining metal and the large step, higher speeds for wood working. The motor drives a jackshaft within the cast iron cabinet back of the lathe. This jackshaft has a 3-step cone for driving the spindle cone and a 2-step cone driven by the belt from the motor.

12 Spindle Speeds are provided—6 for Metal Working and 6 for Wood Working.

A Reversing Switch (Drum Type) conveniently located within easy reach of the operator, controls the motor and provides instantaneous starting, stopping, and reversing of the lathe spindle. The switch has three positions: Left for forward motion of the lathe spindle; Center for stop; and Right for reverse.

The Electrical Equipment included with the drive unit for this lathe consists of: $\frac{1}{2}$ H. P. Constant Speed Reversing Motor, 1200 R. P. M.; Reversing Switch, (Drum Type); Wiring between Motor and Switch; Flexible Metal Conduit; Wiring Diagram; two Leather Belts; Cast Iron Cabinet with Two Speed Drive Mechanism.

Specifications of Electric Current to be used with the motor should be given when ordering. For complete information see page 29.

The Lathe is Thoroughly Tested before shipping. We connect the motor and switch, test and inspect the wiring, then inspect the lathe while operating under its own power.

The Lathe Equipment included in the price consists of: Graduated Compound Rest, Face Plate, Tool Post Complete, two Lathe Centers, Spindle Sleeve, Independent Change Gears, Bolts, Nuts and Washers. Also Installation Plans and book, "How to Run a Lathe."

The Hand Rest, Spur Center, and Cup Center for Wood Turning illustrated above are not included in the price of the 9-inch Junior Combination Metal and Wood Working Lathe but can be furnished at extra cost. See pages 70 and 79.

Easy Payment Prices 9-inch Junior Combination Metal and Wood Working Bench Lathe*

Prices Include Lathe, Two Speed Drive Cabinet, Lathe Equipment, Reversing Motor, Reversing Switch, Two Belts

Catalog No. of Lathe	Swing Over Bed	Length of Bed	Size of Motor	Weight Crated	Code Word	With 3 Phase, 60 Cycle A. C. Motor			With 1 Phase, 60 Cycle A. C. Motor			With Direct Current Motor		
						Price F.O.B. South Bend	Down Payment 20%	12 Equal Monthly Payments	Price F.O.B. South Bend	Down Payment 20%	12 Equal Monthly Payments	Price F.O.B. South Bend	Down Payment 20%	12 Equal Monthly Payments
922-X	$\frac{3}{4}$ in.	$2\frac{1}{2}$ ft.	$\frac{1}{2}$ H.P.	482 lbs.	Bagle	\$272.00	\$54.40	\$19.04	\$300.00	\$60.00	\$21.00	\$283.00	\$56.60	\$19.81
922-Y	$\frac{3}{4}$ in.	3 ft.	$\frac{1}{2}$ H.P.	512 lbs.	Becal	278.00	55.60	19.46	306.00	61.20	21.42	289.00	57.80	20.23
922-Z	$\frac{3}{4}$ in.	$3\frac{1}{2}$ ft.	$\frac{1}{2}$ H.P.	542 lbs.	Belle	284.00	56.80	19.89	312.00	62.40	21.84	295.00	59.00	20.65
922-A	$\frac{3}{4}$ in.	4 ft.	$\frac{1}{2}$ H.P.	572 lbs.	Bimp	291.00	58.20	20.37	318.00	63.60	22.33	302.00	60.40	21.14
922-R	$\frac{3}{4}$ in.	$4\frac{1}{2}$ ft.	$\frac{1}{2}$ H.P.	602 lbs.	Bogel	299.00	59.80	20.93	327.00	65.40	22.89	310.00	62.00	21.70

*The Bench is not included in price of Lathe. See page 70 for Bench prices.

Monthly Payments include carrying charge.

SOUTH BEND, INDIANA, U. S. A.

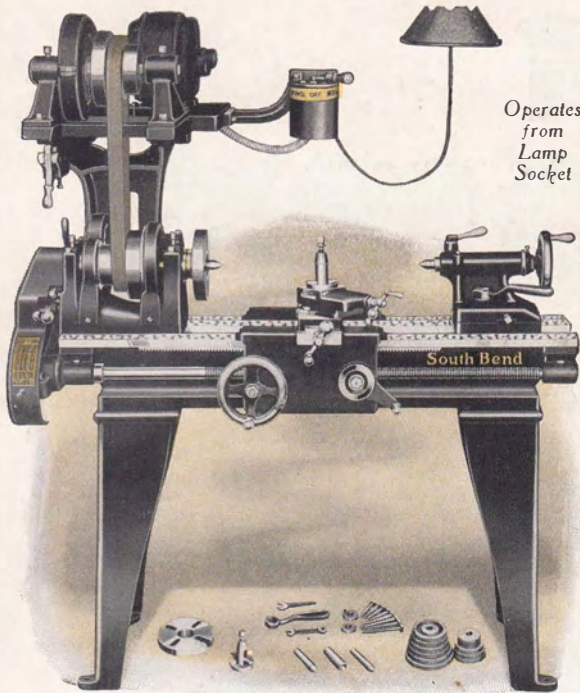

Operates from Lamp Socket

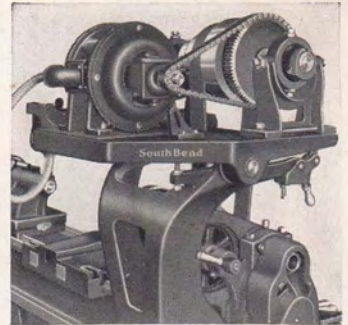

End View of Silent Chain Drive Gear Guard Removed

In the above illustration, the chain guards are removed to show a close-up of the Silent Chain Drive connecting the motor to the upper cone shaft. This improved drive is efficient and practical, and will run for years with no attention other than oiling.

Reversing Switch (Drum Type)

The Reversing Switch (drum type) is conveniently located so that the operator can start, stop, and reverse the motor from an easy working position in front of the lathe. The switch has three positions: Left, for forward motion of lathe spindle, center for stop, and right for reverse motion.

9-inch Jr. New Model Silent Chain Motor Driven Lathe

Back Geared, Screw Cutting Precision Lathe (Floor Leg Type)

The Silent Chain Motor Drive is a practical and efficient drive for the 9-inch Junior Lathe equipped with floor legs. The Silent Chain Drive which connects the motor with the upper cone is as positive as though it were direct geared. A small lever allows the table on which the motor sets to tilt and relieve the belt tension for easy shifting of the belt. An independent adjustment is provided for taking up the stretch of the belt.

For Specifications and Descriptions of the 9-inch Junior Silent Chain Motor Driven Lathes, refer to pages 42 and 43, as the only difference between the 9-inch Junior Silent Chain Motor Driven Lathe and the Overhead Countershaft Driven Lathe is the form of drive.

Operates from Lamp Socket. A 1/4-horsepower reversing motor driven from an ordinary lamp socket gives sufficient power to operate the 9-inch Junior Silent Chain Motor Driven Lathe at maximum capacity. Operating cost averages two cents per hour.

When Ordering a 9-inch Junior Silent Chain Motor Driven Lathe, be sure to specify the electric current. If alternating current, state exact

voltage, phase, cycle and number of wires. If direct current, state exact voltage. When giving voltage of motor, state whether 110-volt motor or 220-volt motor is wanted. Do not specify 110-220-volt motor, as we cannot furnish motors for double voltage rating.

Use Code Word. When ordering a 9-inch Junior Silent Chain Motor Driven Lathe use Code Words listed below to indicate the size of Silent Chain Motor Driven Lathe wanted. Use Code Words shown on page 29 to indicate motor specifications.

Electrical Equipment included in the price of each 9-inch Junior Silent Chain Motor Driven Lathe consists of a 1/4 horsepower Reversing Motor 1200 R.P.M. (Westinghouse, General Electric or equal make), Reversing Switch (Drum Type), wiring between motor and switch, Flexible Metal Conduit, Wiring Diagram, and a Leather Belt.

Lathe Equipment included in the price of each 9-inch Junior Silent Chain Motor Driven Lathe consists of: Face Plate, Tool Post Complete, Two Lathe Centers and Spindle Sleeve, Change Gears for thread cutting, Lag Screws, Washers and Wrenches.

Easy Payment Prices of 9-inch Junior Silent Chair Motor Driven Lathe with Floor Legs

Prices Include Lathe Equipment, Reversing Motor, Reversing Switch and Leather Belt

Catalog No. of Lathe	Swing Over Bed	Length of Bed	Size of Motor	Weight Crated	Code Word	With 3 Phase, 60 Cycle A. C. Motor			With 1 Phase, 60 Cycle A. C. Motor			With Direct Current Motor		
						Price F.O.B. South Bend	Down Payment 20%	12 Equal Monthly Payments	Price F.O.B. South Bend	Down Payment 20%	12 Equal Monthly Payments	Price F.O.B. South Bend	Down Payment 20%	12 Equal Monthly Payments
322-X	9 1/4 in.	2 1/2 ft.	1/4 H.P.	630 lbs.	Bazin	\$277.00	\$55.40	\$19.39	\$292.00	\$58.40	\$20.44	\$285.00	\$57.00	\$19.95
322-Y	9 1/4 in.	3 ft.	1/4 H.P.	650 lbs.	Beuty	283.00	56.80	19.81	298.00	59.60	20.86	291.00	58.20	20.37
322-Z	9 1/4 in.	3 1/2 ft.	1/4 H.P.	670 lbs.	Bower	289.00	57.80	19.81	304.00	60.80	21.29	297.00	59.40	20.79
322-A	9 1/4 in.	4 ft.	1/4 H.P.	690 lbs.	Biolo	296.00	59.20	20.72	311.00	62.20	21.77	304.00	60.80	21.28
322-R	9 1/4 in.	4 1/2 ft.	1/4 H.P.	710 lbs.	Buton	304.00	60.80	21.28	319.00	63.80	22.33	312.00	62.40	21.84

Monthly Payments include carrying charge.

The Small Lathe as a Manufacturing Tool

In the Manufacture of Small Duplicate Parts on a Production Basis

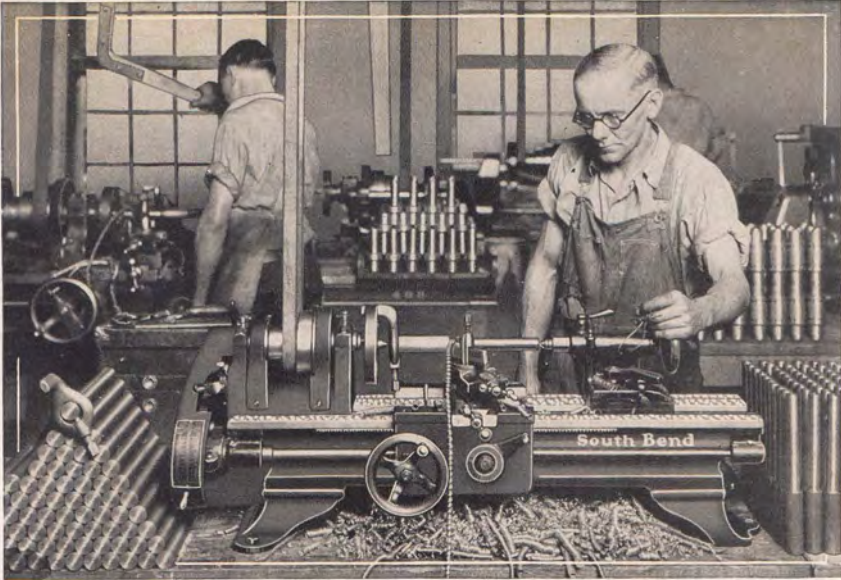

The Latest Shop Practice is to do small work on a small lathe tooled up to take care of the job, because production is far more rapid, accuracy is more easily maintained, the operator makes fewer mistakes and is encouraged by his increased efficiency.

Production Engineers in large manufacturing plants making products such as: Sewing machines, typewriters, electrical parts, etc., are using small lathes in the manufacture of small metal parts that require the greatest accuracy because they must be interchangeable.

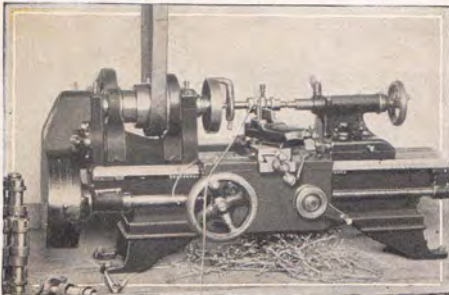

Manufacturing Small Bushings on a 9-inch South Bend Bench Lathe

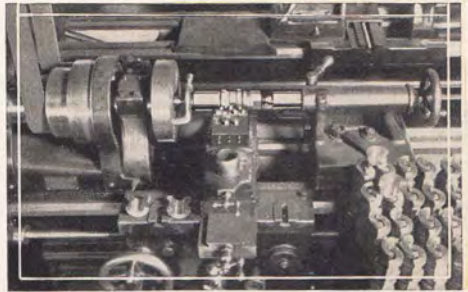

Machining a Job on a Mandrel Between Centers Using Three Cutting Tools

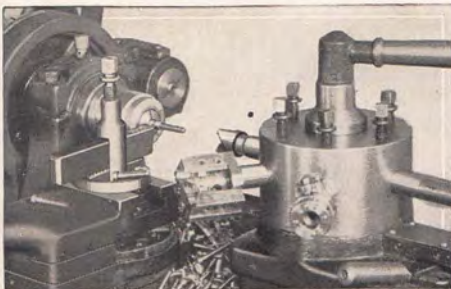

A Lathe Fitted with Hand Lever Draw-in Collet Chuck, and Hand Lever Turret for Making Small Screws



11-inch Lathe with Three Hand Lever-Type Attachments, Draw-in Chuck, Tailstock and Cross Slide

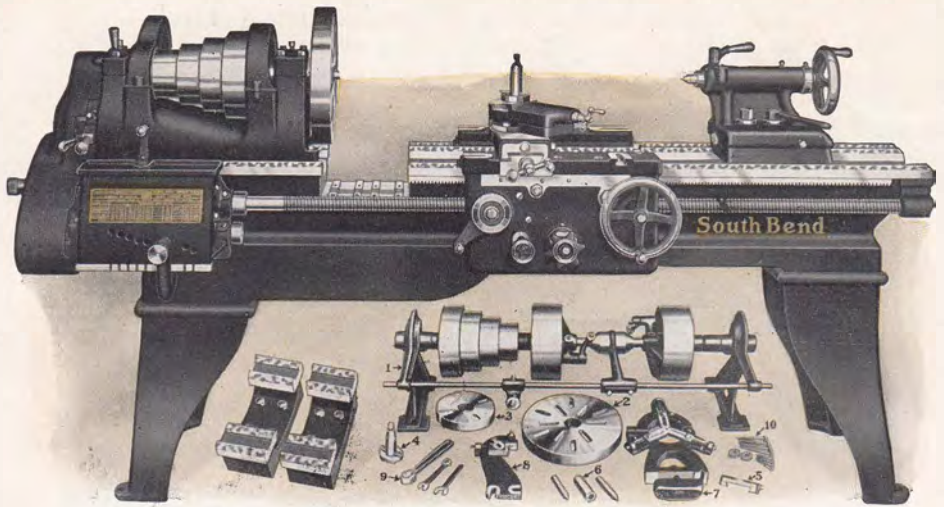

Regular equipment, as illustrated under Lathe, is included in price of Lathe

The New Model Gap Lathes with Double Bridge

Quick Change and Standard Change, Back Geared, Screw Cutting Lathes
Overhead Countershaft Drive

The illustration shows the New Model 18-26-inch Quick Change Gear Gap Lathe with Double Bridge. On Gap Lathes the control levers of the Apron are transposed so that the Carriage can be fed by hand or power over the Gap for machining narrow work.

For description and specifications of any particular size of Gap Lathe refer to a corresponding size of Straight Bed Lathe, as the only difference between the two is the construction of the Bed and Apron which are changed in the Gap Lathe construction.

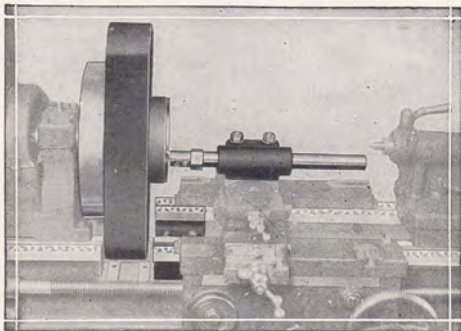

Permits Close Machining on Narrow Work

One Bridge Removed, the Other Remains to Support Carriage

The illustration shows the principle of the Double Bridge in providing proper tool support to the Carriage when machining narrow work. Having one section of the Double Bridge installed eliminates the over-hang of the Carriage and provides the proper tool support under pressure of the cut. The Gap Lathe is practical for the boring and bushing of large pulleys and permits other work of large diameter, like the above, to swing in the Gap of the lathe.



Close-Up of Double Bridge

The Double Bridge is made up of two sections exactly the same in size and of sufficient length to completely fill the Gap in the Bed. Either one or both Bridges may be removed to accommodate the work to be machined. Each Bridge has four holes through which it is clamped to the bed of the lathe and located by Dowel Pins.

Accurately Finished and Fitted

Both Sections of the Double Bridge are very accurately finished and fitted. They are first hand scraped to each other and then to the Lathe Bed. The ways of the Bed are then machined and planed with both Bridges in place. Afterwards they are hand scraped and frosted. The Carriage is fitted to the lathe with both Bridges in place, to insure accuracy. It requires but a few moments to remove or install either one or both sections of the Double Bridge in the Lathe Bed.

The New Model Double Gap Lathes with Double Bridge

Standard and Quick-Change, Back Geared, Screw Cutting Lathes

Below we show prices of the complete New Line of Gap Lathes with Double Bridge, in both Standard and Quick Change Gear Types. There are four sizes of Gap Lathes ranging from 13-inch to 18-inch swing with different Bed Lengths for each swing. The prices listed in the tabulation below are Net Factory Prices, F. O. B. South

Bend, crated for domestic shipment, and include Countershaft and Regular Equipment illustrated under Gap Lathe on page 50. For prices on Silent Chain Motor Driven Gap Lathes, refer to pages 24 to 27 inclusive where the price extra for each size Motor Driven Lathe equipped with Gap Bed is shown in a foot note.

Easy Payment Prices and Specifications

Size of Lathe	Length of Bed	Between Centers	Hole Thru Spindle	Swing Over Gap	Total Width of Gap	Width of Each Bridge	Power Required	Weight Crated	No. of Lathe	Code Word	F.O.B. South Bend	Down Payment 20%	12 Equal Monthly Payments
---------------	---------------	-----------------	-------------------	----------------	--------------------	----------------------	----------------	---------------	--------------	-----------	-------------------	------------------	---------------------------

Quick Change Gear Double Gap Lathes

13-inch—19-inch Double Gap Lathes

13 in.	5 ft.	28 in.	1 in.	19 in.	7 in.	3½ in.	¾ H.P.	1210 lbs.	686-B	Gestr	\$508.00	\$101.60	\$35.56
13 in.	6 ft.	40 in.	1 in.	19 in.	7 in.	3½ in.	¾ H.P.	1260 lbs.	686-C	Glatt	\$523.00	104.60	36.61
13 in.	7 ft.	52 in.	1 in.	19 in.	7 in.	3½ in.	¾ H.P.	1310 lbs.	686-D	Geyn	\$540.00	108.00	37.80
13 in.	8 ft.	64 in.	1 in.	19 in.	7 in.	3½ in.	¾ H.P.	1360 lbs.	686-E	Gidan	\$559.00	111.80	39.13

15-inch—22-inch Double Gap Lathes

15 in.	5 ft.	24½ in.	1½ in.	22 in.	8 in.	4 in.	1 H.P.	1600 lbs.	688-B	Laeta	600.00	120.00	42.00
15 in.	6 ft.	36½ in.	1½ in.	22 in.	8 in.	4 in.	1 H.P.	1675 lbs.	688-C	Lavor	618.00	123.60	43.26
15 in.	7 ft.	48½ in.	1½ in.	22 in.	8 in.	4 in.	1 H.P.	1750 lbs.	688-D	Links	636.00	127.20	44.52
15 in.	8 ft.	60½ in.	1½ in.	22 in.	8 in.	4 in.	1 H.P.	1860 lbs.	688-E	Lotry	656.00	131.20	45.92
15 in.	10 ft.	84½ in.	1½ in.	22 in.	8 in.	4 in.	1 H.P.	2025 lbs.	688-G	Lozen	700.00	140.00	49.00

16-inch—24-inch Double Gap Lathes

16 in.	6 ft.	34 in.	1¾ in.	24 in.	8¼ in.	4½ in.	1 H.P.	2015 lbs.	692-C	Macou	683.00	136.60	47.81
16 in.	7 ft.	46 in.	1¾ in.	24 in.	8¼ in.	4½ in.	1 H.P.	2095 lbs.	692-D	Malds	703.00	140.60	49.21
16 in.	8 ft.	58 in.	1¾ in.	24 in.	8¼ in.	4½ in.	1 H.P.	2175 lbs.	692-E	Medic	723.00	144.60	50.61
16 in.	10 ft.	82 in.	1¾ in.	24 in.	8¼ in.	4½ in.	1 H.P.	2375 lbs.	692-G	Melte	767.00	153.40	53.69
16 in.	12 ft.	106 in.	1¾ in.	24 in.	8¼ in.	4½ in.	1 H.P.	2495 lbs.	692-II	Mezto	830.00	166.00	58.10

18-inch—26-inch Double Gap Lathes

18 in.	6 ft.	29½ in.	1½ in.	26 in.	10 in.	5 in.	2 H.P.	2610 lbs.	694-C	Sabin	813.00	162.60	56.91
18 in.	7 ft.	41½ in.	1½ in.	26 in.	10 in.	5 in.	2 H.P.	2710 lbs.	694-D	Salty	838.00	167.60	58.66
18 in.	8 ft.	53½ in.	1½ in.	26 in.	10 in.	5 in.	2 H.P.	2810 lbs.	694-E	Sande	863.00	172.60	60.41
18 in.	10 ft.	77½ in.	1½ in.	26 in.	10 in.	5 in.	2 H.P.	3010 lbs.	694-G	Saint	917.00	183.40	64.19
18 in.	12 ft.	101½ in.	1½ in.	26 in.	10 in.	5 in.	2 H.P.	3310 lbs.	694-H	Savor	995.00	199.00	68.65
18 in.	14 ft.	125½ in.	1½ in.	26 in.	10 in.	5 in.	2 H.P.	3710 lbs.	694-K	Sawte	1057.00	211.40	73.99

Standard Change Gear Double Gap Lathes

13-inch—19-inch Double Gap Lathes

13 in.	5 ft.	28 in.	1 in.	19 in.	7 in.	3½ in.	¾ H.P.	1210 lbs.	635-B	Gleta	448.00	89.60	31.36
13 in.	6 ft.	40 in.	1 in.	19 in.	7 in.	3½ in.	¾ H.P.	1260 lbs.	635-C	Glost	463.00	92.60	32.41
13 in.	7 ft.	52 in.	1 in.	19 in.	7 in.	3½ in.	¾ H.P.	1310 lbs.	635-D	Golfe	480.00	96.00	33.60
13 in.	8 ft.	64 in.	1 in.	19 in.	7 in.	3½ in.	¾ H.P.	1360 lbs.	635-E	Gomez	499.00	99.80	34.93

15-inch—22-inch Double Gap Lathes

15 in.	5 ft.	24½ in.	1½ in.	22 in.	8 in.	4 in.	1 H.P.	1600 lbs.	639-B	Luber	525.00	105.00	36.75
15 in.	6 ft.	36½ in.	1½ in.	22 in.	8 in.	4 in.	1 H.P.	1675 lbs.	639-C	Lucky	543.00	108.60	38.01
15 in.	7 ft.	48½ in.	1½ in.	22 in.	8 in.	4 in.	1 H.P.	1750 lbs.	639-D	Ludlo	561.00	112.20	39.27
15 in.	8 ft.	60½ in.	1½ in.	22 in.	8 in.	4 in.	1 H.P.	1860 lbs.	639-E	Lufte	581.00	116.20	40.67
15 in.	10 ft.	84½ in.	1½ in.	22 in.	8 in.	4 in.	1 H.P.	2025 lbs.	639-G	Lynch	625.00	125.00	43.75

16-inch—24-inch Double Gap Lathes

16 in.	6 ft.	34 in.	1¾ in.	24 in.	8¼ in.	4½ in.	1 H.P.	2015 lbs.	641-C	Mnce	603.00	120.60	42.21
16 in.	7 ft.	46 in.	1¾ in.	24 in.	8¼ in.	4½ in.	1 H.P.	2095 lbs.	641-D	Mouse	623.00	124.60	43.61
16 in.	8 ft.	58 in.	1¾ in.	24 in.	8¼ in.	4½ in.	1 H.P.	2175 lbs.	641-E	Month	643.00	128.60	45.01
16 in.	10 ft.	82 in.	1¾ in.	24 in.	8¼ in.	4½ in.	1 H.P.	2335 lbs.	641-G	Mytha	687.00	137.40	48.09
16 in.	12 ft.	106 in.	1¾ in.	24 in.	8¼ in.	4½ in.	1 H.P.	2495 lbs.	641-H	Mykro	750.00	150.00	52.50

18-inch—26-inch Double Gap Lathes

18 in.	6 ft.	29½ in.	1½ in.	26 in.	10 in.	5 in.	2 H.P.	2610 lbs.	643-C	Seaso	723.00	144.60	50.61
18 in.	7 ft.	41½ in.	1½ in.	26 in.	10 in.	5 in.	2 H.P.	2710 lbs.	643-D	Sebal	748.00	149.60	52.36
18 in.	8 ft.	53½ in.	1½ in.	26 in.	10 in.	5 in.	2 H.P.	2810 lbs.	643-E	Sedri	773.00	154.60	54.11
18 in.	10 ft.	77½ in.	1½ in.	26 in.	10 in.	5 in.	2 H.P.	3010 lbs.	643-G	Sefol	827.00	165.40	57.89
18 in.	12 ft.	101½ in.	1½ in.	26 in.	10 in.	5 in.	2 H.P.	3310 lbs.	643-H	Serme	905.00	181.00	63.35
18 in.	14 ft.	125½ in.	1½ in.	26 in.	10 in.	5 in.	2 H.P.	3710 lbs.	643-K	Sekita	967.00	193.40	67.69

For prices of Gap Bed Lathes with Silent Chain Motor Drive see footnotes on pages 24 to 27. Monthly Payments include carrying charge.

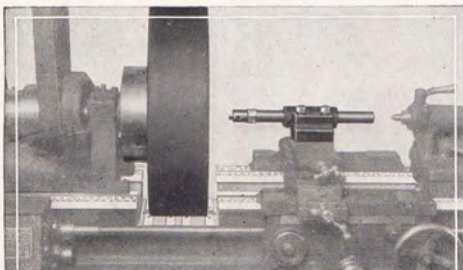

Double Bridge Removed from Gap for Extremely Wide Work

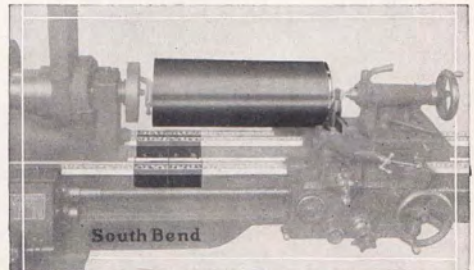

Double Bridge in Place Permits Using Lathe as a Straight Bed

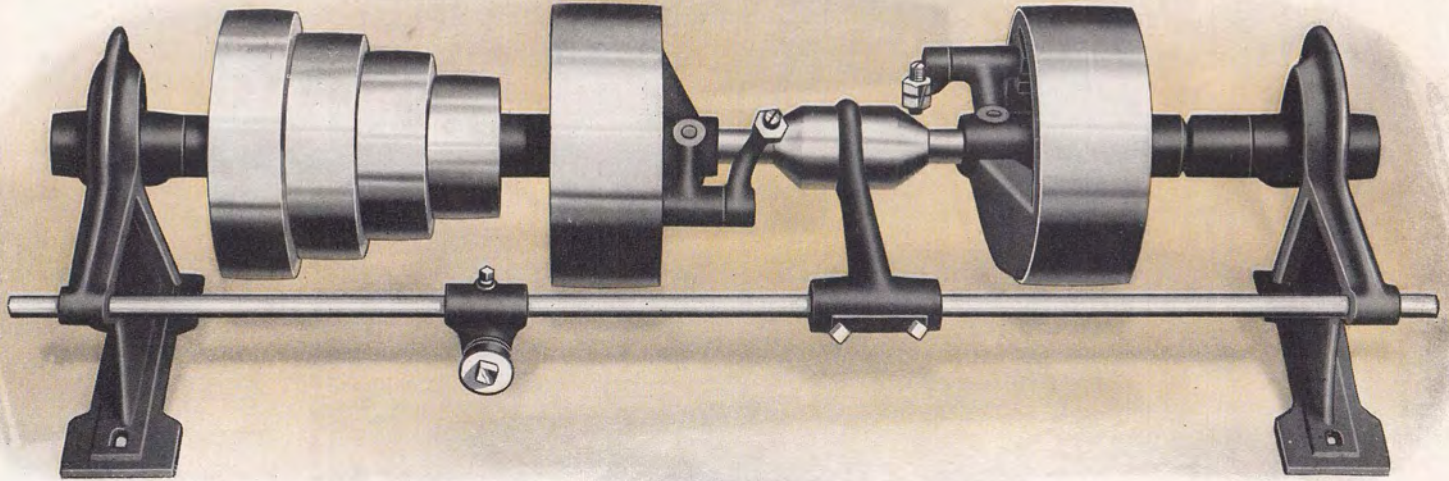

The New Double Friction Countershaft for New Model South Bend Lathes

Furnished with All Types of Countershaft Driven South Bend Lathes

The New Double Friction Countershaft illustrated above is used for driving all New Model South Bend Lathes from the lineshaft. It is practical and powerful with all parts balanced so that it can be operated at high speed without vibration.

The Two Friction Drive Pulleys are equipped with Friction Clutches which expand against the rim and are adjustable for any gripping tension desired. One of these pulleys is used for forward drive and the other for reversing the spindle through a cross belt.

The Countershaft Bearings are adjustable and self-aligning in the hangers. Oil Reservoirs equipped with large felt wicks, distribute oil for lubricating hubs of clutch pulleys and countershaft bearings.

Four-step Cone Pulleys are furnished on countershafts for New Model South Bend Lathes 13-inch to 18-inch, inclusive. Three-step cone pulleys are furnished on countershafts for 9-inch and 11-inch lathes. The shaft on which the cone pulleys are mounted is made of finest quality ground steel shafting.

Two-Speed Countershaft. The Double Friction Countershaft may be arranged as a two-speed countershaft which permits sixteen speeds. This is obtained by attaching a pulley of large diameter on the lineshaft, to drive the friction pulley regularly used for the reverse. This arrangement gives eight higher speeds to the lathe spindle for machining brass, bronze, aluminum, etc.

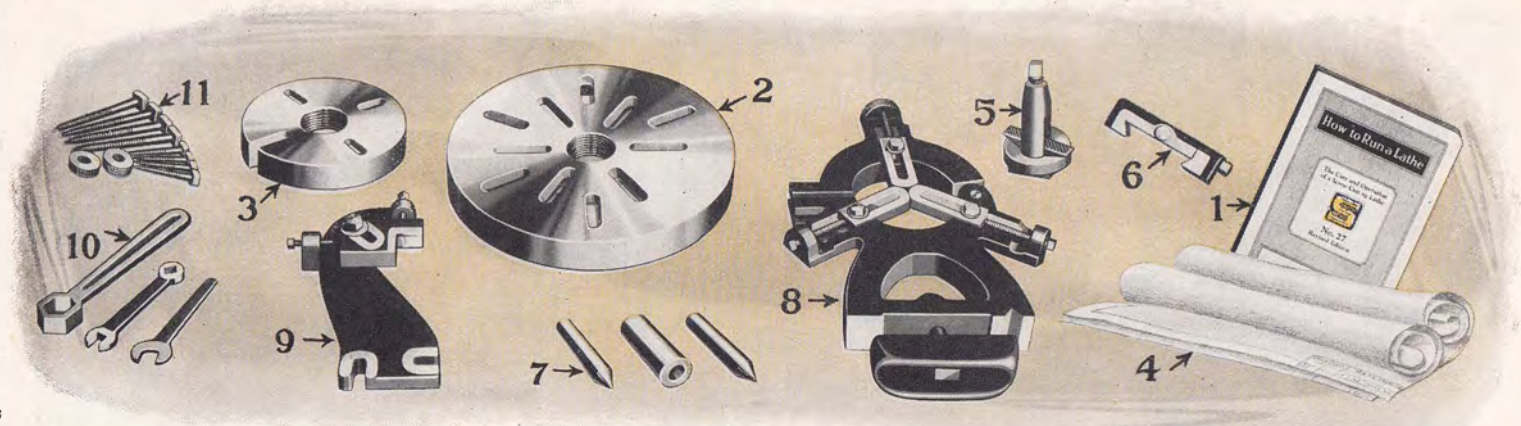

Regular Lathe Equipment Furnished with New Model South Bend Lathes—All Types

Quick Change and Standard Change Gear, Countershaft and Motor Drive Types*

The Regular Equipment illustrated above is included in the price of all types of New Model South Bend Lathes. Each part is described below.

1. The Instruction Book, "How to Run a Lathe" is a very valuable reference for the mechanic. See page 94.
2. The Large Face Plate is threaded and fitted to the spindle nose.
3. The Small Face Plate is threaded and fitted to the spindle nose.
4. The Installation Plan Blue Prints furnished with the equipment of each lathe show how to install and erect the lathe. See pages 80 and 81.
5. Tool Post, Ring and Wedge made of drop forged steel, case-hardened.

6. Adjustable Thread Cutting Stop used for regulating depth of chip in thread cutting.

7. Two Tool Steel Lathe Centers: The soft center and taper sleeve are for the Headstock Spindle—the hardened center is for the Tailstock Spindle.

8. Center Rest for supporting long, slender work while being turned. It is also used when drilling, boring, reaming, threading, etc.

9. Follower Rest travels with the cutting tool, and is used to support long, slender work, while being machined.

10. Wrenches for Tailstock, Compound Rest and Tool Post.

11. Lag Screws, for fastening the countershaft and lathe.

Gears for Threads and Feeds—for Standard Change Gear Lathes

Independent Change Gears for threading and turning feeds, are furnished with all Standard Change Gear Lathes. These gears are used for cutting standard screw threads right and left as indicated on the Index Plate attached to each lathe.



Independent Change Gears

These Independent Change Gears also provide for the adjustment of the automatic cross and longitudinal feeds, and are included in the regular equipment and price of all Standard Change Gear Lathes.

SOUTH BEND TRADE MARK ENGINE LATHES		
13-15-10		
THREAD	SINGLE	SCREW
2	72	24
3	48	24
4	36	24
5	48	40
6	48	48
7	48	56
8	48	64
9	48	72
10	48	80
11	24	44
11 1/2	24	46
12	24	48
13	24	92
14	24	56
16	24	72
18	24	80
20	24	80
24	24	44
26	24	48
28	24	52
30	24	50
32	24	64
36	24	72
40	24	80

SOUTH BEND LATHE WORKS
SOUTH BEND, INDI., U. S. A.

*Large Face Plate, Adjustable Thread Cutting Stop, Center Rest and Follower Rest are not included in price of the 9" Junior Lathes.

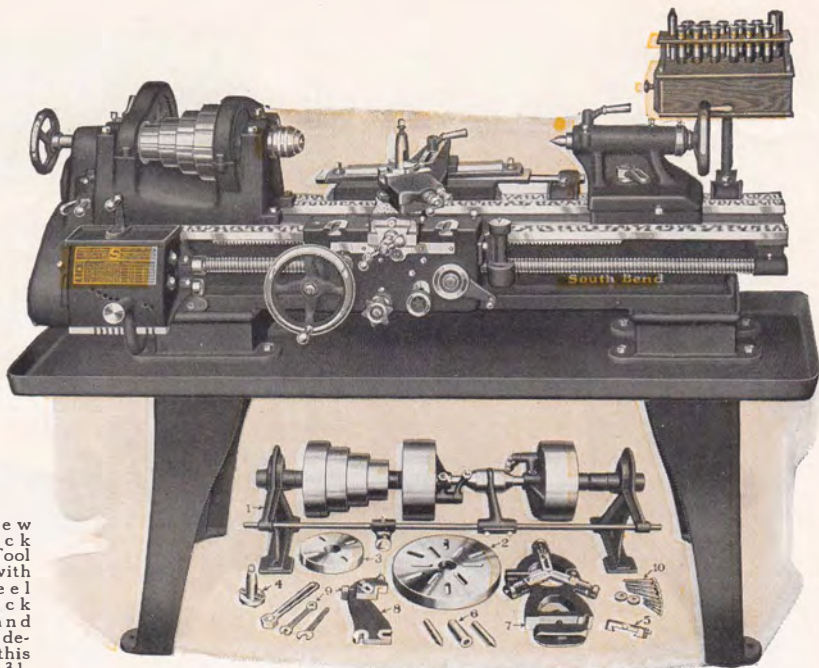

13" x 5' New Model Quick Change Gear Tool Room Lathe with Hand Wheel Draw-in Chuck Attachment and collets. For description of this lathe see page 31.

Draw-in Collet Chuck Attachments For All Sizes and Types of South Bend Lathes

For Tool Room Work

The Hand Wheel Type Draw-in Collet Chuck Attachment is used extensively in the Tool Room in making small tools and parts where accuracy is essential. It is the most accurate type of chuck made and is the choice of experienced tool makers and machinists for fine, accurate work.

For Manufacturing

The Draw-in Collet Chuck, both Hand Wheel Type and Hand Lever Type, is used for manufacturing small, precision parts such as watches, typewriters, sewing machines, adding machines, radios, etc. The hollow draw bar permits bars and rods being passed through the lathe spindle and held in the chuck for machining. This method of manufacturing small parts is both rapid and economical.

How the Draw-in Collet Chuck Operates

The hollow draw bar extending through the lathe spindle operates the hardened and ground steel split collet. As the draw bar is rotated the threads in the end of the draw bar cause the collet to tighten or release the work.

In the Hand Wheel Type Draw-in Collet Chuck the collet is operated by turning the hand wheel which causes it to grip or release the work held in the collet.

In the Hand Lever Type Draw-in Collet Chuck the collet is operated by means of the hand lever, permitting the work to be gripped or released while the spindle is in motion. A special adjustment is provided for changing the tension or gripping action of the collet.

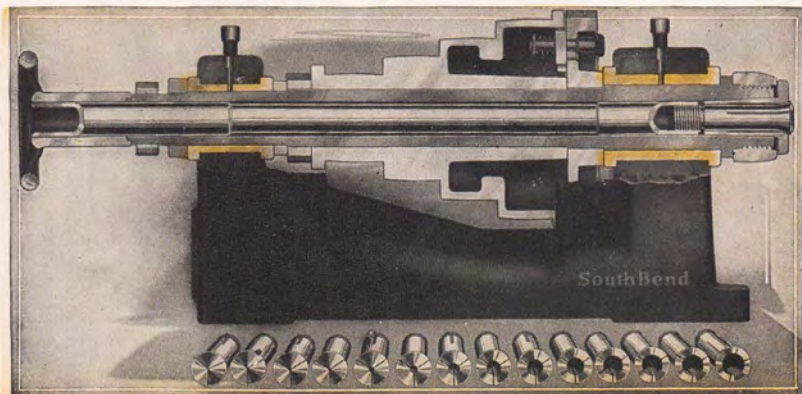

A cross section of the Headstock showing Hand Wheel Draw-in Collet Chuck

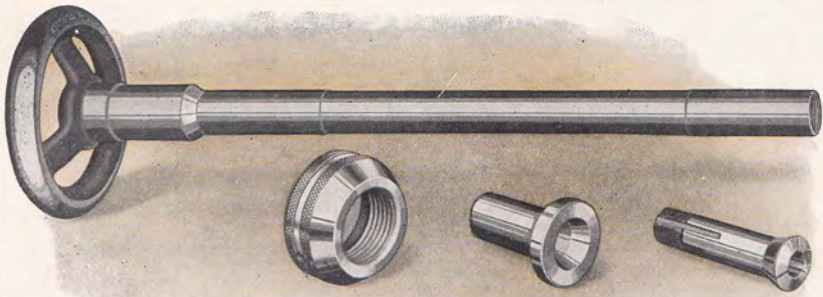

Hand Wheel Type Draw-in Collet Chuck with One Split Collet, Tapered Closing Sleeve, and Nose Cap for Protecting Spindle Nose Threads

Hand Wheel Type Draw-in Collet Chuck Attachment

For All Sizes and Types of South Bend Lathes

Made in Six Sizes

The Draw-in Collet Chuck Attachment is made in six (6) different sizes to conform to the six different sizes of New Model South Bend Lathes. The capacity of the Draw-in Collet Chuck is limited by the size of the hole in the spindle of the lathe on which it is used. For specifications and prices see tabulation below.

What the Price Includes

The price of the Hand Wheel Draw-in Collet Chuck Attachment includes hand wheel and hollow draw bar, nose cap for protecting threads of spindle nose, tapered steel closing sleeve for attaching collet to headstock spindle, and one round, split collet of any size desired up to the maximum capacity of lathe. The tapered closing sleeve furnished with this attachment is made of tool steel, hardened and ground, to minimize wear and insure accuracy.

For Manufacturing and Tool Room Work

The Draw-in Collet Chuck is used on the small lathe to great advantage for the manufacturing of small accurate metal parts. The skilled mechanic and tool maker are very partial to the draw-in collet chuck attachment as it permits the greatest accuracy in making small parts on such work as tool making and production work. The draw-in collet chuck is the most accurate type of chuck that can be used on a lathe.

Sizes and Types of Collets Furnished

Collets are furnished for the hand wheel draw-in collet chuck in sizes ranging from $\frac{3}{8}$ inch hole diameter to hole capacity of lathe by 64ths, 32nds, and 16ths, as shown in the tabulation below. These sizes are regularly carried in stock. Collets of special hole sizes can be furnished as required. For complete information on collets see bottom of page, also next page.

Prices Hand Wheel Draw-in Chuck Attachment with One Collet

Size of Lathe	Catalog No.	Hole in Lathe Spindle	Collet Capacity in Sixty-Fourths (for Round Work)	Code Word	Price Each
9 in.	4309	$\frac{3}{8}$ in.	$\frac{3}{8}$ in. up to $\frac{1}{2}$ in.	Aaron	\$33.00
11 in.	4311	$\frac{7}{8}$ in.	$\frac{7}{8}$ in. up to $\frac{3}{4}$ in.	Abode	38.00
13 in.	4313	1 in.	$\frac{3}{4}$ in. up to $\frac{5}{8}$ in.	About	44.00
15 in.	4315	$1\frac{1}{8}$ in.	$\frac{5}{8}$ in. up to $\frac{3}{4}$ in.	Above	50.00
16 in.	4316	$1\frac{3}{8}$ in.	$\frac{3}{4}$ in. up to $\frac{7}{8}$ in.	Adore	56.00
18 in.	4318	$1\frac{1}{2}$ in.	$\frac{7}{8}$ in. up to 1 in.	Adult	63.00

Split Collets for Round Work

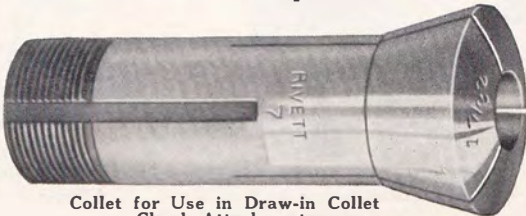

Collet for Use in Draw-in Collet Chuck Attachments

At the left is shown a split collet. All collets for Draw-in Collet Chuck Attachments used on the New Model South Bend Lathes are made of tool steel, hardened and tempered. They are ground both outside and inside to insure accuracy. The left end is threaded for the hollow draw bar and has a keyway to prevent the collet from turning while holding the work. The other end is tapered to conform to the tapered closing sleeve furnished with the attachment. Three slots permit the collet to close or release as the tension on the hollow draw bar is increased or decreased.

Net Factory Prices of Split Collets for Round Work

Size of Lathe	Catalog No.	Hole in Lathe Spindle	Collet Capacity in Sixty-Fourths (for Round Work)	Code Word	Price Each
9 in.	609	$\frac{3}{8}$ in.	$\frac{3}{8}$ in. up to $\frac{1}{2}$ in.	Cabot	\$3.85
11 in.	611	$\frac{7}{8}$ in.	$\frac{7}{8}$ in. up to $\frac{3}{4}$ in.	Cello	4.40
13 in.	613	1 in.	$\frac{3}{4}$ in. up to $\frac{5}{8}$ in.	Chose	5.00
15 in.	615	$1\frac{1}{8}$ in.	$\frac{5}{8}$ in. up to $\frac{3}{4}$ in.	Civit	5.50
16 in.	616	$1\frac{3}{8}$ in.	$\frac{3}{4}$ in. up to $\frac{7}{8}$ in.	Clear	6.00
18 in.	618	$1\frac{1}{2}$ in.	$\frac{7}{8}$ in. up to 1 in.	Comet	6.50

When Ordering Extra Collets for Draw-in Collet Chuck Attachments specify size of hole in collet and size of lathe for which collet is wanted. These collets fit both hand wheel and hand lever types of Draw-in Collet Chuck Attachments.

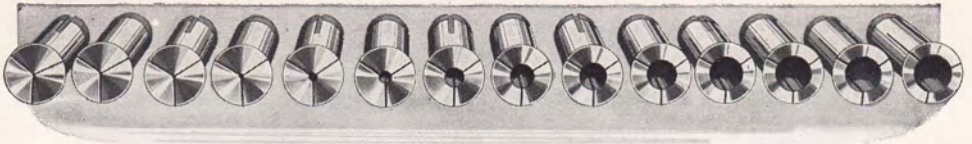

Split Collets for Draw-in Chuck Attachments

Range of Collet Sizes

The illustration above shows a group of collets ranging from the smallest size up to 1-inch size in steps of sixteenths (16ths) of an inch. The smallest collet is adapted to work $\frac{1}{16}$ -inch in diameter. The next is adapted to work $\frac{1}{8}$ -inch in diameter, etc.

Collets from $\frac{1}{16}$ -inch diameter to hole capacity (shown in the price tabulation on page 55) by 64ths, 32nds, and 16ths of an inch are regularly carried in stock. Special hole sizes such as odd diameter drill and wire gauges, and metric sizes can be furnished if required.

This permits the manufacturer of tools and dies to use the correct size collets for all special tool and gauge work, and enables the manufacturer of duplicate parts to select the size and type collet to suit his exact requirements. This insures accuracy of the finished work and increases production.

Three Types of Split Collets

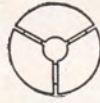

Round



Square



Hexagon

The illustrations above show three types of split collets used in the Hand Wheel and Hand Lever Draw-in Chuck Attachments to hold Round, Square or Hexagonal stock. Round collets are the most widely used for manufacturing and in the tool room, therefore we carry this type only, in stock. For prices see page 55. Square or Hexagonal collets are made to order. Prices quoted on request.

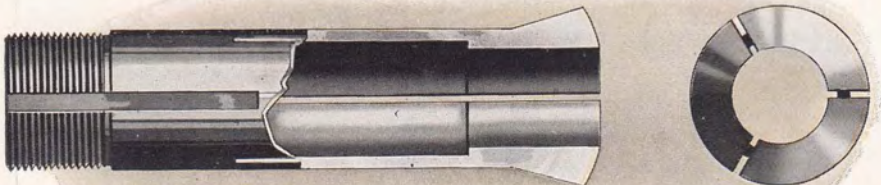

Cross-Section of Split Collet from Side and Front View

Above is illustrated a cross section of the hardened and ground tool steel collet. Notice the three slots which divide the tapered end of the collet into three segments. This permits the

collet to be contracted or expanded as it is drawn into or released from the tapered closing sleeve in the lathe spindle. This construction makes it the most accurate chuck on the market.

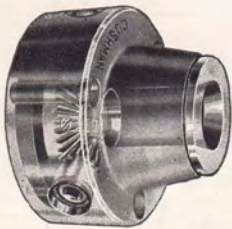

Spindle Nose Collet Chuck

CAPACITY: Bar work up to capacity of lathe spindle; short work up to 1 3/4 inches.

Above is illustrated the Spindle Nose Type Collet Chuck which requires no draw bar. The body of the chuck is fitted to face plate which screws on the spindle nose of the lathe. The collet is actuated by a wrench which operates a mechanism inside the chuck, causing it to be drawn in or released at will of the operator. This permits using full hole capacity of the lathe spindle so that larger work can be handled than in the draw-in chuck. Prices of Chuck and Collets quoted on request.

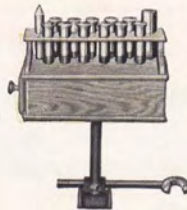
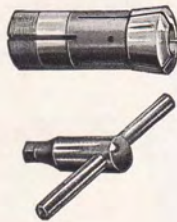

The Collet Cabinet provides an easy and convenient means of holding collets, centers, wrenches, small tools, etc. Price includes bracket for attaching to the lathe.

Size Lathe	Cat. No.	Code Word	Net Price
9 in.	1081	Caged	\$12.00
11 in.	1082	Crome	12.00
13 in.	1083	Cnole	12.00
15 in.	1084	Charl	15.00
16 in.	1085	Cadro	15.00
18 in.	1086	Catch	15.00

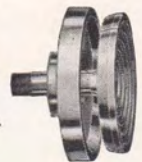

Step Chuck and Closer

The Step Chuck and Closer is used instead of the split collet for holding round discs and similar work. Prices quoted on request. In ordering give sizes of blanks to be machined.

Hand Lever Type Draw-in Collet Chuck Attachment

For All Sizes and Types of South Bend Lathes

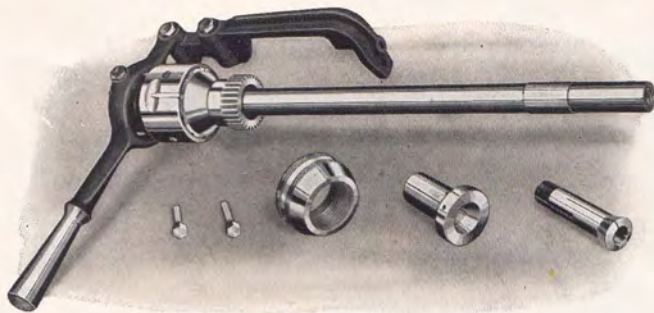

The Hand Lever Draw-in Collet Chuck permits releasing and feeding bar stock through the collet, without stopping the lathe, by means of an adjustable chuck closer. The gripping action of the collet can be adjusted to any desired tension by regulating the cylinder of the adjustable chuck closer. Price includes one round collet; tapered closing sleeve, nose cap, hollow draw bar, and adjustable chuck closing mechanism ready to use.

The Tapered Closing Sleeve furnished with the Hand Lever Draw-in Collet Chuck is made of tool steel, hardened and ground, to minimize wear and insure accuracy.

The Hand Lever Draw-in Collet Chuck Attachment is a very economical tool for use in manufacturing small interchangeable parts, where accuracy and precision are essential.

Net Factory Prices of Hand Lever Draw-in Collet Chuck Attachment with One Collet

Size of Lathe	Catalog No.	Hole in Lathe Spindle	Collet Capacity in Sixty-fourths (for Round Work)	Code Words	Price Each
9 in.	5209	$\frac{3}{8}$ in.	$\frac{3}{8}$ in. up to $\frac{1}{2}$ in.	Allen	\$ 75.00
11 in.	5211	$\frac{7}{8}$ in.	$\frac{3}{8}$ in. up to $\frac{3}{8}$ in.	Among	85.00
13 in.	5213	1 in.	$\frac{3}{8}$ in. up to $\frac{3}{8}$ in.	Andes	105.00
15 in.	5215	$1\frac{1}{8}$ in.	$\frac{3}{8}$ in. up to $\frac{3}{8}$ in.	Askev	110.00
16 in.	5216	$1\frac{3}{8}$ in.	$\frac{3}{8}$ in. up to $\frac{7}{8}$ in.	Aster	120.00
18 in.	5218	$1\frac{7}{8}$ in.	$\frac{3}{8}$ in. up to 1 in.	Atoll	160.00

Application of Draw-in Collet Chuck Attachments

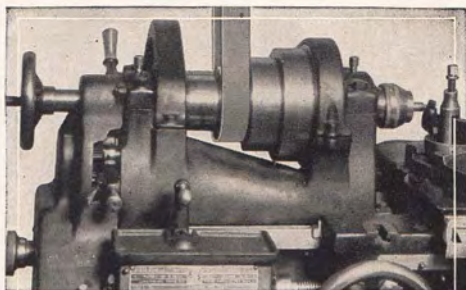

Hand Wheel Draw-in Collet Chuck Attachment on a Tool Making Job Machining Special Pins



Hand Lever Type Draw-in Collet Chuck Forming and Cutting Off Duplicate Parts from Bar Stock

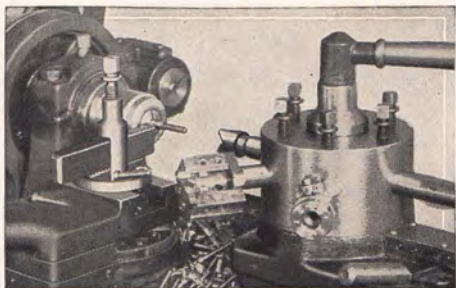

Draw-in Collet Chuck Attachment Used with Turret Attachment for Making Duplicate Parts

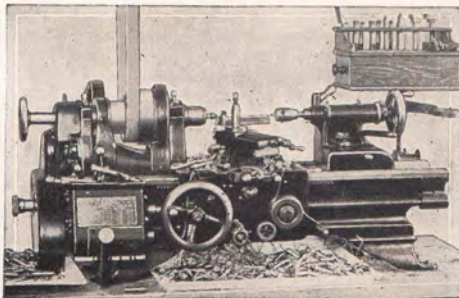

9-inch Quick Change Gear Bench Lathe with Hand Wheel Draw-in Collet Chuck Manufacturing Small Screws

Graduated Taper Attachment for South Bend Lathes

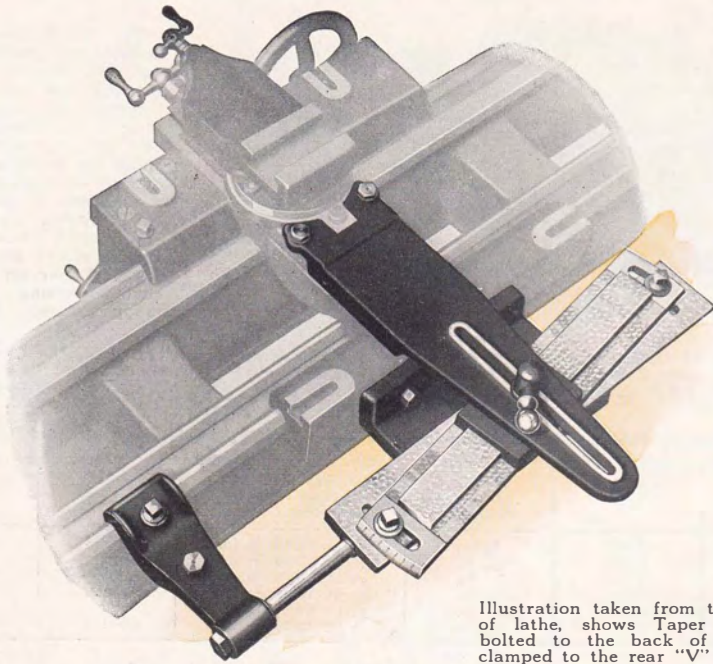

Illustration taken from the rear side of lathe, shows Taper Attachment bolted to the back of Saddle and clamped to the rear "V" way of bed.

Graduated Taper Attachment Fitted to a 16-inch South Bend Lathe

The Taper Attachment is used for tool room work, manufacturing and production work for turning and boring all classes of taper work. It is especially practical on production work where a large number of duplicate parts are to be taper machined by turning or boring. The attachment may be left on the lathe at all times when doing either taper or straight work. It requires only a couple of minutes to change the taper attachment from straight to taper machining or vice-versa. The taper attachment illustrated above on a 16-inch Lathe is the same design used on all size lathes differing only in dimension.

Taper Attachment Can Be Operated Entire Length of Bed

The Taper Attachment is bolted to the Lathe carriage and can be set for taper turning or boring at any position along the entire length of the lathe bed. The Taper Attachment does not interfere with straight turning as it does not operate unless the clamp on the back "V" of the bed is locked.

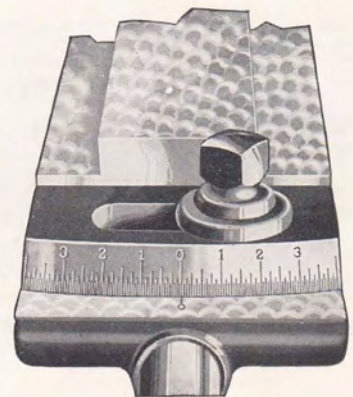

Close-up of Graduation

On the End Showing Inches per Foot

The Swivel Bar, which controls the Taper, is graduated—one end in inches per foot of taper and the other end in degrees. The attachment can be set for any Taper up to 3 inches per foot.

It is advisable to order the Taper Attachment with the lathe, so that it can be fitted at the factory; although it may be ordered at any time and attached by the customer, as the saddle is machined to receive the Taper Attachment.

Net Factory Prices

Size of Lathe	Catalog No.	Length of Taper at One Setting	Maximum Taper Per Foot	Maximum Taper in Degrees	Approximate Shipping Weight	Code Word	Price Taper Attachment
9 in.	209	9 in.	3 in.	14	40 lbs.	Dashe	\$50.00
11 in.	211	9 in.	3 in.	14	50 lbs.	Devor	60.00
13 in.	213	10 in.	3 in.	14	65 lbs.	Digit	75.00
15 in.	215	10 in.	3 in.	14	80 lbs.	Doted	80.00
16 in.	216	12 in.	3 in.	14	100 lbs.	Dress	90.00
18 in.	218	12 in.	3 in.	14	120 lbs.	Dunns	95.00

Thread Indicator for the New South Bend Lathes

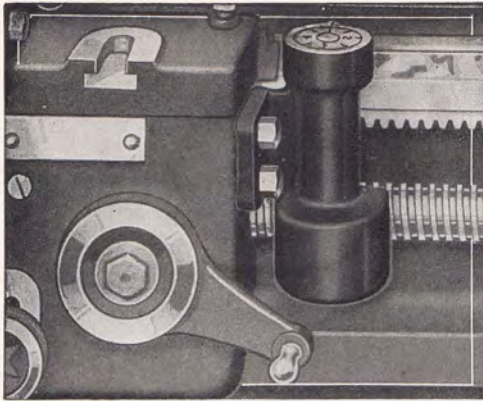

Thread Indicator Fitted to the Carriage of the Lathe

The Thread Indicator eliminates the necessity of reversing the lathe to return the Carriage to the starting point to catch the thread at the beginning of each successive cut.

Shows Proper Position for Engaging Half Nuts

The Face of the Dial is numbered and graduated to show the exact time to clamp the Half Nuts on the Lead Screw for the next cut. When cutting even threads, the Half Nuts are closed at any graduation on the Dial and for odd threads at any numbered line on the Dial.

For pitches involving $\frac{1}{2}$ of a thread, such as $11\frac{1}{2}$ per inch, the Half Nuts are closed at any odd numbered graduation.

Net Factory Prices of Thread Indicator

Size of Lathe.....	9 in.	11 in.	13 in.	15 in.	16 in.	18 in.
Catalog No.....	809	811	813	815	816	818
Code Word.....	Abaft	Acres	Advis	Aesop	Aflot	Agrol
Price, Each.....	\$8.00	\$8.00	\$10.00	\$10.00	\$12.00	\$12.00

Micrometer Carriage Stop for the New South Bend Lathes

The Micrometer Carriage Stop, shown at right is useful in manufacturing operations and in accurate facing of work. It can be used as either a permanent or adjustable stop. Special means are provided for clamping the Micrometer Carriage Stop to the front "V" of the lathe bed, so that it does not mar or injure the hand-scraped surface.

Graduated Barrel

The revolving barrel is graduated on one end in thousandths of an inch and knurled on the other so that it can be rotated easily. The adjusting bar or stop is hardened on both ends and is provided with a lock so that the bar may be fastened at any point for duplicate work.

Net Factory Prices of Micrometer Carriage Stop

Size of Lathe....	9 in.	11 in.	13 in.	15 in.	16 in.	18 in.
Catalog No.....	971	972	973	974	975	976
Code Word.....	Calef	Celed	Chain	Cikar	Climb	Cora
Price, Each.....	\$10.00	\$12.00	\$13.00	\$14.00	\$15.00	\$17.00

Micrometer Carriage Stop with multiple stops. Prices on application.

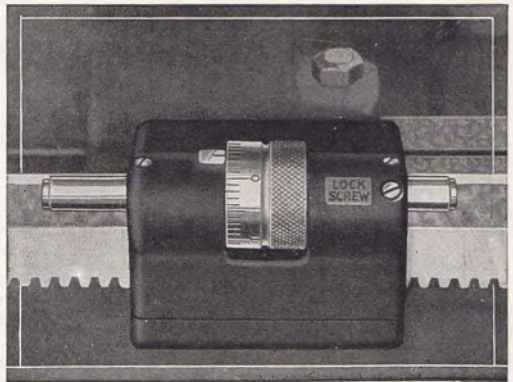

Micrometer Carriage Stop Fitted to Lathe Bed as a Permanent or Adjustable Stop

Relieving Attachment for the New South Bend Lathes

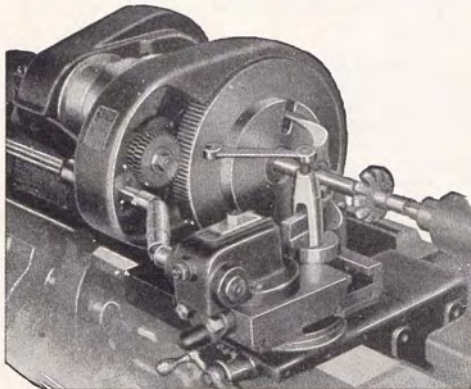

Relieving Attachment in Use on the Lathe for Relieving a Formed Cutter

This Attachment does every kind of relieving except spiral and has an unlimited range of angular work. It can be quickly changed from relieving to plain turning, thread cutting or vice versa. It has a graduated scale for amount of relief from 0 to $\frac{3}{8}$ inch.

Work Which Can Be Relieved

The diameter of work that can be relieved on a 15-inch Lathe is 6 inches—on a 16-inch Lathe, 6 inches—on an 18-inch Lathe, 7 inches. The class of work that can be relieved consists of: Milling cutters, reamers, taps, hobs, etc. It is also arranged for internal relieving of threading dies, etc. This attachment should be ordered with the lathe so that it can be properly fitted at the factory.

Net Factory Prices of Relieving Attachment

Size of Lathe	Cat. No.	Code Word	Price Each	Size of Lathe	Cat. No.	Code Word	Price Each
15 in.	953	David	\$350.00	18 in.	955	Diver	\$400.00
16 in.	954	Delta	355.00				

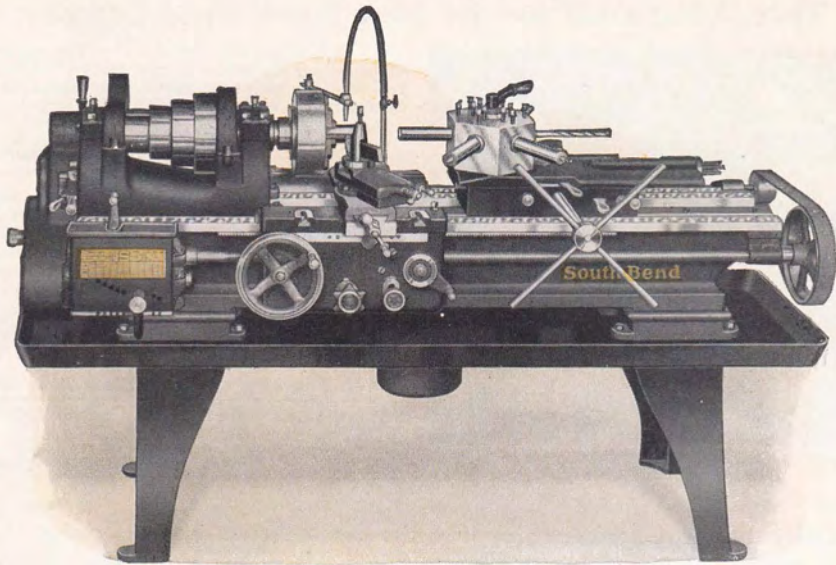

The New Model Lathe Equipped for Manufacturing Work

The Back Geared Screw Cutting Lathe Equipped with a Few Special Tools Makes an Efficient Machine for the Production of Small Duplicate Metal Parts

The New Model South Bend Back Geared Screw Cutting Lathe can be fitted with a variety of attachments and used to advantage for many manufacturing operations. A lathe equipped in this way serves the purpose of a Special Machine. When the job is finished the tools can be removed and the lathe used for regular lathe work.

Mechanics who have worked in some of the modern metal working plants in the United States know from experience that the screw cutting lathe as a manufacturing tool is used to great advantage in machining metal parts in large quantities. Any size South Bend Lathe from 9-inch to 18-inch size inclusive may be equipped with tools for special production work.

The back geared screw cutting lathe is a universal tool and can be equipped at a small expense with a set of tools for machining duplicate parts where accuracy and precision is required. Many modern industrial plants are taking advantage of this fact and are using screw cutting lathes. Some plants are using screw cutting lathes in groups on production work and getting excellent results.

There are many jobs where the screw cutting lathe thus equipped will show a bigger production on parts than can be obtained on a special or single purpose machine. When one job is finished the screw cutting lathe can then be

equipped and set up for doing various jobs, and can be kept in operation the year round. The single purpose machine is capable of doing only one job, in some cases it is not in operation half the time, which makes it an expensive and unprofitable investment.

Steel Oil Pan for South Bend Lathes

The illustration above shows the New Model South Bend Lathe equipped with a heavy one-piece Steel Oil Pan. This type of Pan can be furnished with any size or style of South Bend Lathe. A special oil-tight construction makes this Pan especially desirable when a cooling liquid is used on the work.

The depth and length of the Steel Oil Pan varies according to the size of the lathe, but the proportions are generous. The Pan is sufficiently long to extend beyond the ends of the lathe bed so that there is no danger of oil or chips falling to the floor.

Should Be Ordered with the Lathe

This Pan requires lathe legs of a special construction and should be ordered with the lathe so that it can be fitted at the factory. The prices below are for Steel Oil Pan and special legs instead of regular legs and do not include any of the other equipment illustrated above.

Net Factory Prices Steel Oil Pan for South Bend Lathes

Size of Lathe	Catalog Number	LENGTH OF BED							
		3-foot Beds	3½-foot Beds	4-foot Beds	4½-foot Beds	5-foot Beds	6-foot Beds	7-foot Beds	8-foot Beds
9 in.	282	\$20.00	\$21.00	\$22.00	\$23.00				
11 in.	284	25.00	26.00	27.00		\$29.00			
13 in.	286			35.00		38.00	\$41.00	\$44.00	\$47.00
15 in.	288					45.00	48.00	53.00	57.00
16 in.	292						50.00	55.00	60.00
18 in.	294						55.00	60.00	65.00
Code Words		Oasis	Oback	Odium	Often	Ohern	Okres	Olean	Omens

Semi-Automatic Turnstile Bed Turret (Hand Feed)

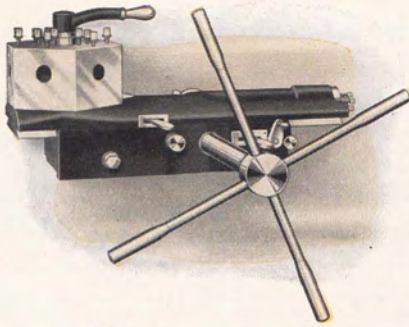

The Turnstile Bed Turret illustrated at the left is called Semi-Automatic because the turret revolves automatically one-sixth of a turn on the return stroke of each hand revolution of the turnstile. Adjustable stops are provided for each of the six faces of the turret for regulating the depth of each tool operation. The feed of the turret slide is controlled by turning the turnstile by hand.

The Six Holes in the turret are rough drilled to within $\frac{1}{8}$ -inch of the finished diameter. The finished boring of these turret holes must be done in the shop where the turret lathe is to be put into operation, so that the mechanic can fit his tools to the job and to the turret holes.

Fitting the Bed Turret to the lathe consists of fitting the bottom of the turret slide to the "V" way and flat way of the lathe bed, so that the holes of the turret, when finish bored, will be concentric with the axis of the lathe spindle, or the point of the lathe center. Fitting does not include finish boring of turret tool holes.

Power Feed to the turret slide is extra, and prices may be had upon request. The illustration at bottom of page shows a lathe fitted with bed turret which has power feed to the turret slide. This feed is shown on the left end of the lathe.

Prices of Turnstile Bed Turrets

Size of Lathe	Catalog No.	Size of Hole	Maximum Turret Feed	Weight Each	Code Word	*Price Each
13 in.	413	1 in.	9 in.	200 lbs.	Felow	\$275.00
15 in.	415	1 in.	9 in.	225 lbs.	Fight	300.00
16 in.	416	1 in.	9 in.	225 lbs.	Flovn	305.00
18 in.	418	1 1/4 in.	12 in.	550 lbs.	Ports	350.00

*Fitting Turnstile Bed Turret is extra. Prices on application.

Semi-Automatic Hand Lever Bed Turret (Hand Feed)

The Semi-Automatic Hand Lever Bed Turret automatically indexes $\frac{1}{6}$ of a turn by the backward movement of the hand lever. Adjustable stops are provided for each of the six faces of the turret for regulating the depth of each tool. The feed of the turret slide is controlled by the hand lever. The Semi-Automatic Hand Lever Bed Turret cannot be fitted with power feed.

The Six Holes in the turret are rough drilled to within $\frac{1}{8}$ inch of the finished diameter. The finished boring of these turret holes must be done in the shop where the turret lathe is to be put into operation, so that the mechanic can fit his tools to the job and to the turret holes.

Fitting the Bed Turret to the lathe consists of fitting the bottom of the turret slide to the "V" way and flat way of the lathe bed, so that the holes of the turret, when finish bored, will be concentric with the axis of the lathe spindle. Fitting does not include finish boring of turret tool holes.

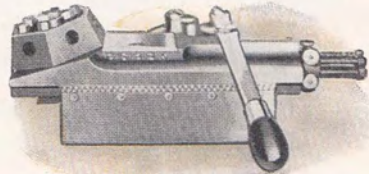

Prices of Semi-Automatic Bed Turret

Size of Lathe	Cat. No.	Turret Hole	Length of Turret Base	Max. Turret Feed	Weight Each	Code Word	*Price of Turret
9 in.	1509	5/8 in.	9 1/2 in.	4 1/2 in.	40 lbs.	Jaber	\$195.00
11 in.	1511	5/8 in.	9 1/2 in.	4 1/2 in.	60 lbs.	Jenks	205.00
13 in.	1513	5/8 in.	9 1/2 in.	4 1/2 in.	75 lbs.	Jilts	215.00

*Fitting Semi-Automatic Bed Turret is extra. Prices on application.

Oil Pump, Reservoir and Pipe Fittings for South Bend Lathes

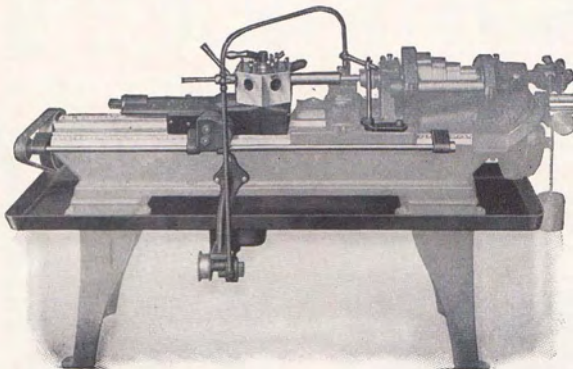

Rear View of a New Model South Bend Lathe Equipped with Oil Pan, Reservoir and Piping

The illustration at the left shows the lathe equipped with Oil Pump, Reservoir and Pipe Fittings. Any South Bend Lathe from the 9-inch to the 18-inch Lathe inclusive can be equipped with these parts.

The Nozzle of the Flexible Steel Pipe is attached to a bracket mounted on the Carriage of the Lathe, causing it to travel with the Lathe Tool. A valve for regulating the flow of the liquid is conveniently located in the pipe line at the back of the lathe.

The Reservoir is cast iron and bolts directly to the Steel Pan usually at the end of the Lathe. A Sieve construction above the Reservoir strains the liquid and prevents chips from entering. A screw plug in the bottom provides drainage.

The Oil Pump, Reservoir and Fittings should be ordered with the Lathes in order to be properly fitted at the factory. Prices on application.

Milling and Keyway Cutting Attachment for South Bend Lathes

Takes Care of a Wide Variety of Machine Work

Fits on Saddle of Lathe

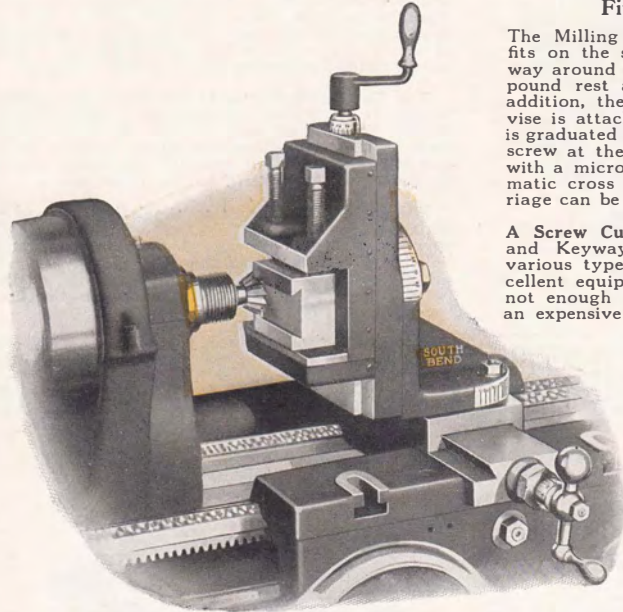

The Milling and Keyway Cutting Attachment fits on the saddle of the lathe, swivels all the way around in a horizontal plane like the compound rest and is graduated 180 degrees. In addition, the upright Angle Plate to which the vise is attached swivels in a vertical plane, and is graduated 180 degrees. The vertical adjusting screw at the top of the attachment is equipped with a micrometer graduated collar. The automatic cross and longitudinal feeds of the carriage can be used as well as the hand feeds.

A Screw Cutting Lathe fitted with a Milling and Keyway Cutting Attachment and using various types of milling cutters makes an excellent equipment for the small shop that has not enough of this class of work to invest in an expensive milling machine.

The Milling Arbors and Cutters that are used with the Milling Attachment are illustrated and priced on page 63 of this catalog. If milling cutters, other than those shown, are wanted, we will be pleased to furnish illustrations, description and prices on request.

The Skilled Mechanic can use the Milling Attachment on the lathe for hundreds of different kinds of jobs, both in tool and production work.

Milling a Dovetail on a South Bend Lathe

The South Bend Milling and Keyway Cutting Attachment is valuable for the small shop because it equips the lathe for doing a great deal of work that otherwise could be done only on a shaper or milling machine. It will be appreciated by the experienced mechanic because in addition to cutting keyways a wide variety of machine work can be taken care of. A few of the various jobs that show the application of the attachment are illustrated below and on page 63.

The Milling and Keyway Cutting Attachment is designed for use on South Bend Lathes, and therefore, we cannot guarantee that it can be fitted to lathes of other makes. The Equipment consists of milling attachment, two steel "V" blocks for holding round work, one crank handle for feed screw, one double end wrench, T-bolts and nuts for attaching to carriage. The Milling Arbor and Cutters are not included in the price of the Milling Attachment. For prices on Arbor and Cutters see page 63.

Net Factory Prices of Milling and Keyway Cutting Attachment

Size of Attachment	Size of Lathe	Vertical Feed	Cross Feed	Vise Will Hold	Depth of Jaws	Width of Jaws	Width of Base	Weight Each	Code Word	Price Each
No. 1	9 in.	3 in.	7 in.	1½ in.	1½ in.	3½ in.	3¼ in.	25 lbs.	Vagon	\$40.00
No. 2	11 in.	4 in.	8 in.	1½ in.	1½ in.	3½ in.	3¾ in.	30 lbs.	Valet	45.00
No. 3	13 in.	4¼ in.	9 in.	2¼ in.	1½ in.	4¼ in.	5 in.	40 lbs.	Vieto	50.00
No. 4	15 in.	6 in.	11 in.	3½ in.	1½ in.	5½ in.	5½ in.	50 lbs.	Visit	65.00
No. 5	16 in.	6 in.	10¾ in.	4 in.	2 in.	5¾ in.	5¾ in.	65 lbs.	Varen	75.00
No. 5½	18 in.	6½ in.	14 in.	4 in.	2 in.	5¾ in.	6½ in.	75 lbs.	Voxar	85.00

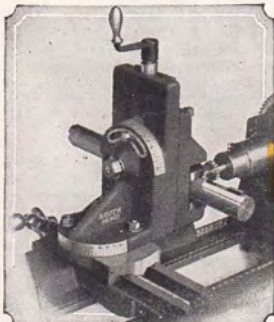

Milling a Woodruff Keyway

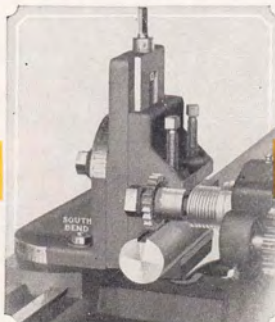

Milling a Standard Keyway

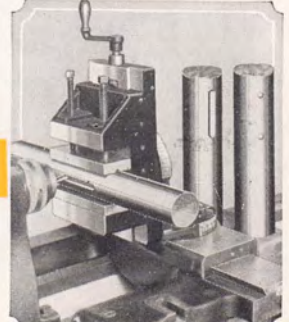

Milling a Keyway in Shaft

Practical Jobs for the Milling Attachment on the Lathe

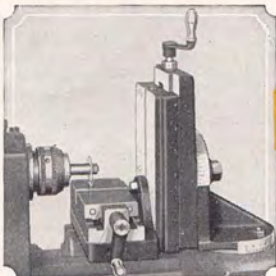

Fig. A—Horizontal Vise Fixture

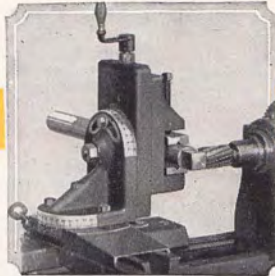

Fig. B—Squaring Steel Shaft

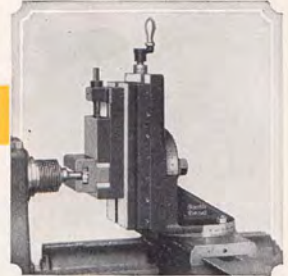

Fig. C—Vertical Vise Fixture

Horizontal Vise Fixture.—Fig. A shows the Milling Attachment fitted with a Vertical Adjustable Fixture to which is attached a Horizontal Angle Plate fitted with a Standard Vise. The prices below are for the Vertical Fixture, Angle Plate and Vise, and do not include the Milling Attachment.

Prices Include Vertical Fixture, Angle Plate and Vise								
Lathe Size	Cat. No.	Code Word	Net Price	Lathe Size	Cat. No.	Code Word	Net Price	
9 in.	Not Made	13 in.	1306	Vedal	\$46.50	
			Not Made	15 in.	1307	Veget	47.50	
			Not Made	16 in.	1308	Veitor	50.00	
11 in.	Not Made	18 in.	1310	Velum	55.00	

The above prices do not include the Milling and Keyway Cutting Attachment, prices of which are shown on page 62

Vertical Vise Fixture.—Fig. C shows the Milling Attachment fitted with Vertical Adjustable Fixture and a Standard Vise. The prices below are for the Vertical Fixture and Vise, and do not include the Milling Attachment. For prices of Milling Attachments see page 62.

Prices Include Vertical Fixture and Vise								
Size Lathe	Cat. No.	Code Word	Net Price	Size Lathe	Cat. No.	Code Word	Net Price	
9 in.	Not Made	13 in.	1322	Vafer	\$43.50	
			Not Made	15 in.	1323	Vaint	45.00	
			Not Made	16 in.	1324	Vakid	47.50	
11 in.	Not Made	18 in.	1325	Vampe	52.50	

Millling Cutters and Arbors for South Bend Lathes

Arbor for Side and Plain Milling Cutters



For holding cutters with standard 1-in. hole. Capacity between nut and shoulder is 1 1/4 in. Three spacing collars and hardened nut are furnished with each arbor. The Taper Shank is ground to fit the head spindle of the lathe.

Net Factory Prices of Arbors for Milling Cutters

Size Lathe	Cat. No.	Morse Taper	Code Word	Price Each	Size Lathe	Cat. No.	Morse Taper	Code Word	Price Each
9 in.	109	No. 3	Kacel	\$9.00	11 in.	115	No. 3	Kdoxl	\$ 9.00
11 in.	111	Special	Kbosh	9.00	16 in.	116	No. 3	Kempy	10.00
13 in.	113	No. 3	Keite	9.00	18 in.	118	No. 3	Kferd	10.00

Plain Milling Cutters

Made of High Speed steel, properly hardened and ground. Will cut on face only. All cutters have 1-inch hole and standard keyway.

Net Factory Prices of Plain Milling Cutters (High Speed Steel)

Size Lathe	Cat. No.	Width of Face	Diameter of Cutter	Diameter of Hole	Code Word	Price Each
	849-A	3/8 in.	2 1/2 in.	1 in.	Naber	\$3.25
	849-B	3/8 in.	2 1/2 in.	1 in.	Nbolst	3.50
	849-C	3/8 in.	2 1/2 in.	1 in.	Ncefl	3.75
	849-D	3/8 in.	2 1/2 in.	1 in.	Ndixo	4.00
	849-E	3/8 in.	2 1/2 in.	1 in.	Nedop	4.25
	849-F	3/8 in.	2 1/2 in.	1 in.	Nfenz	4.50
	849-G	3/8 in.	2 1/2 in.	1 in.	Ngord	4.80
	849-H	3/8 in.	2 1/2 in.	1 in.	Nhaxk	5.40
	849-I	3/8 in.	2 1/2 in.	1 in.	Nidar	6.00
	849-K	1 in.	2 1/2 in.	1 in.	Njoke	6.50

Special Collet Chuck for Woodruff Cutters

The Collet Chuck holds Woodruff Milling Cutters with straight shank 1/2 inch in diameter. Taper Shank fits head spindle of lathe. Cutter is not included in price of arbor.



Net Factory Prices of Collet Chuck for Woodruff Cutters

Size Lathe	Catalog No.	Code Word	Price Each	Size Lathe	Catalog No.	Code Word	Price Each
9 in.	101	Rabet	\$8.00	15 in.	104	Rodny	\$8.00
11 in.	102	Resta	8.00	16 in.	105	Rsyma	8.00
13 in.	103	Ritho	8.00	18 in.	106	Rusty	8.00

Side Milling Cutters

Made of High Speed steel, properly hardened and ground. Will cut on face and either side. All cutters have 1-inch hole and standard keyway.

Net Factory Prices Side Milling Cutters (High Speed Steel)

Catalog No.	Width of Face	Diameter of Cutter	Diameter of Hole	Code Word	Price Each
850-A	1/4 in.	3 in.	1 in.	Oates	\$ 5.40
850-B	3/8 in.	3 in.	1 in.	Oband	6.25
850-C	1/2 in.	3 in.	1 in.	Ocpis	6.65
850-D	3/4 in.	3 in.	1 in.	Odate	7.15
850-E	1 in.	3 in.	1 in.	Oehft	7.65
850-F	3/8 in.	3 1/2 in.	1 in.	Ofare	10.65
850-G	3/4 in.	4 in.	1 in.	Ogest	14.40
850-H	1 in.	4 in.	1 in.	Ohugo	17.30
850-I	1 in.	5 in.	1 in.	Oieda	20.20

Spiral End Mills

Made of High Speed steel, hardened and ground. Morse Standard Taper Shanks. Right-Hand Mill only furnished.

Net Factory Prices of Spiral End Mills (High Speed Steel)

Cat. No.	Diam. of Mill	Morse Taper	Code Word	Price Each	Cat. No.	Diam. of Mill	Morse Taper	Code Word	Price Each
868-A	3/8 in.	No. 2	Pablo	\$4.15	870-A	3/8 in.	No. 3	Fraiz	\$6.00
868-B	1/2 in.	No. 2	Peals	4.60	870-B	1/2 in.	No. 3	Fpsalm	6.20
868-D	3/8 in.	No. 2	Phial	4.60	870-C	1 in.	No. 3	Fpult	6.20
868-E	3/8 in.	No. 2	Pinke	4.60	870-D	1 1/2 in.	No. 3	Fpwat	7.10
868-F	3/8 in.	No. 2	Plaid	5.30	870-E	1 1/2 in.	No. 3	Fpsyc	8.25
868-G	1 in.	No. 2	Ponds	5.75					

Woodruff System Milling Cutters

Made of High Speed steel, properly hardened and ground. Have straight shanks 1/2 inch in diameter. For milling Woodruff System Keyways.

Net Factory Prices Woodruff System Milling Cutters (High Speed Steel)

Cat. No.	Diam.	Width	Code Word	Price Each	Cat. No.	Diam.	Width	Code Word	Price Each
897-A	1/2 in.	1/8 in.	Uabed	\$1.80	897-I	1 in.	1/4 in.	Uitoo	\$3.60
897-B	3/8 in.	1/8 in.	Uboas	1.80	897-J	1 1/4 in.	3/8 in.	Ujvis	3.60
897-C	3/8 in.	1/8 in.	Ucedx	2.10	897-K	1 1/2 in.	3/8 in.	Ukase	4.00
897-D	3/8 in.	1/8 in.	Udwin	2.50	897-L	1 3/4 in.	3/8 in.	Ulaft	4.00
897-E	3/8 in.	1/8 in.	Ueyos	2.50	897-M	1 3/4 in.	3/8 in.	Umine	4.00
897-F	3/8 in.	1/8 in.	Ufent	2.75	897-N	1 3/4 in.	3/8 in.	Uineda	4.50
897-G	3/8 in.	1/8 in.	Ugers	2.75	897-O	1 3/4 in.	3/8 in.	Uopre	4.50
897-H	1 in.	3/8 in.	Uhoml	3.60	897-P	1 3/4 in.	3/8 in.	Uplat	4.50

Lathe Chucks for South Bend Lathes

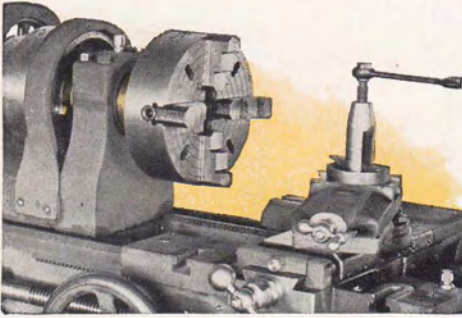

Lathe Equipped with Four-Jaw Chuck

Independent Lathe Chucks With Four Reversible Jaws (Iron Body)

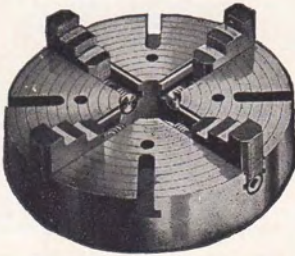

The Independent Chuck has four independent solid jaws with individual screw adjustment which may be set as required for chucking round or irregular work, either in a concentric or in an eccentric position. The face of Chuck is ground true to a straight edge and is accurately graduated in inches. The jaws are reversible by running out at the edge and turning end for end. All chucks are made with hardened steel bearings for the screws. T-slots are furnished only on chucks 12 inches and larger.

Prices include wrench and four cap screws for fastening chuck back to chuck. Prices do not include chuck back or fitting of chuck to lathe. See page 65.

Net Factory Prices of the Independent Chuck

Cat. No.	Rated Size of Chuck	Will Hold About	Shipping Weight	Code Word	Price Chuck
2104	4½ in.	6 in.	11 lbs.	Bawle	\$23.00
2106	6 in.	7½ in.	21 lbs.	Beach	28.00
2108	8 in.	9½ in.	35 lbs.	Buzir	32.00
2109	9 in.	11½ in.	42 lbs.	Baito	35.00
2110	10 in.	12½ in.	51 lbs.	Balda	40.00
2112	12 in.	14½ in.	90 lbs.	Baled	48.00
2114	14 in.	16½ in.	117 lbs.	Balks	52.00
2115	15 in.	18 in.	139 lbs.	Balmy	57.00
2116	16 in.	19 in.	147 lbs.	Bandu	62.00
2118	18 in.	21 in.	184 lbs.	Bankr	80.00

The Practical Type of Chuck for the Lathe
If the lathe is to have one chuck, it should be an Independent Lathe Chuck with 4 reversible jaws, as this type will hold either round or irregular shaped work. If two chucks are to be fitted to the lathe, then a Universal Geared Scroll Chuck should be used in addition to the Independent 4-jaw reversible type. A Universal Geared Scroll Chuck is self-centering and therefore enables the operator to handle round and hexagonal stock without losing time in truing up the work.

Information on Ordering Lathe Chucks

In ordering a chuck for the lathe, there are two important points to consider. These are (1) SIZE OF CHUCK best suited to your work and (2) FITTING CHUCK to the Lathe. These points are fully explained below and on page 65.

Three-Jaw Universal Geared Scroll Chucks With Two Sets of Jaws (Iron Body)

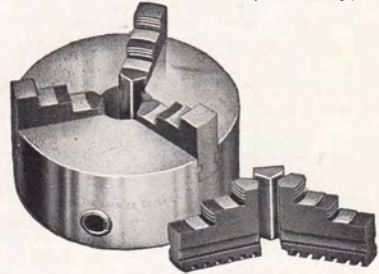

The 3-Jaw Universal Geared Scroll Chuck is intended for holding round and hexagonal work in a concentric position. It is strictly a Universal Chuck, the jaws being moved simultaneously by the scroll threaded plate. This self-centering feature makes it unnecessary to center each piece of work to be chucked. Two sets of jaws are furnished with this type of chuck—the No. 1 or Common Jaws for gripping work on the outside—the No. 2 or Reverse Jaws for holding work internally.

Prices appearing below include wrench, two complete sets of Jaws and cap screws for fastening chuck back to chuck. Prices do not include chuck back or fitting of chuck to Lathe. See page 65.

Net Factory Prices Three-Jaw Universal Chuck

Cat. No.	Rated Size of Chuck	Will Hold About	Shipping Weight	Code Word	Price Chuck
2403	3 in.	3½ in.	3½ lbs.	Panel	\$ 25.00
2404	4 in.	4½ in.	7½ lbs.	Paras	29.00
2405	5 in.	5 in.	11 lbs.	Parot	31.00
2406	6 in.	6½ in.	20 lbs.	Pasto	35.00
2407	7½ in.	7½ in.	32 lbs.	Patri	41.00
2409	9 in.	9 in.	45 lbs.	Pedal	49.00
2410	10½ in.	10½ in.	64 lbs.	Perag	55.00
2412	12 in.	12 in.	80 lbs.	Pensi	64.00
2415	15 in.	15 in.	143 lbs.	Perse	91.00
2418	18 in.	18 in.	180 lbs.	Perfu	119.00

The Proper Sizes of Chucks for South Bend Lathes

To assist those who wish to select the proper sizes of chucks for South Bend Lathes we list in the table below the sizes of chucks most practical for general work with each size lathe. We also show the maximum sizes which are the largest possible to use on the lathe.

Size of Lathe	4-Jaw Independent Lathe Chuck		3-Jaw Universal Geared Scroll Chuck		3-Jaw Drill Chuck	
	Recommended	Maximum	Recommended	Maximum	Recommended	Maximum
9 in. lathe.....	6 in.	6 in.	4 in.	6 in.	½ in.	5/8 in.
11 in. lathe.....	6 in.	8 in.	5 in.	7½ in.	½ in.	5/8 in.
13 in. lathe.....	8 in.	10 in.	6 in.	9 in.	¾ in.	¾ in.
15 in. lathe.....	9 in.	12 in.	7½ in.	10½ in.	¾ in.	¾ in.
16 in. lathe.....	10 in.	12 in.	9 in.	10½ in.	1 in.	1 in.
18 in. lathe.....	12 in.	14 in.	10½ in.	12 in.	1 in.	1 in.

Fitting a Lathe Chuck to the Lathe

In order to mount a lathe chuck on the lathe the chuck must be fitted with a semi-machined chuck back.

Fitting a chuck to the lathe is a difficult job for the small shop, especially if the mechanic lacks the special equipment of tools needed for the work.

In ordering your lathe we recommend that you order the chuck at the same time so that we can fit the chuck to the lathe here in our factory.

We have special machinery and tools for doing this work and years of experience in fitting chucks so that they will run true.

Semi-machined Chuck Back

The illustration shows a Semi-machined Cast Iron Chuck Back which has been bored, faced and threaded to fit the spindle nose of the Lathe. Sufficient stock is left on the diameter of the flange so that it can be machined to fit the recess on the back of the chuck.

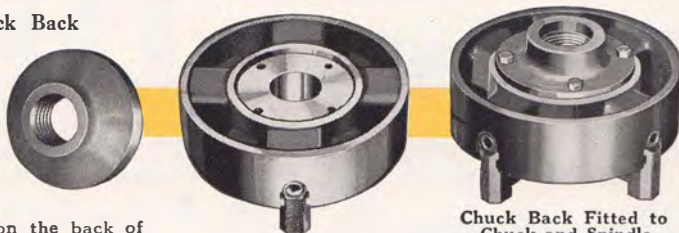

Rear Side of Chuck

Chuck Back Fitted to Chuck and Spindle Nose of Lathe

Net Factory Prices of Semi-machined Chuck Backs—Also Fitting Chuck Back to Chuck and Lathe

Sizes of South Bend Lathes.....	9 in.	11 in.	13 in.	15 in.	16 in.	18 in.
Prices of Semi-machined Chuck Back.....	\$4.00	\$4.25	\$4.50	\$4.75	\$5.00	\$5.50
Code Word for Semi-machined Chuck Back	Conat	Cavor	Cekam	Cimer	Clame	Cuban
Fitting Semi-machined Chuck Back to Chuck and to Lathe.....	\$3.00	\$3.25	\$3.50	\$3.75	\$4.00	\$4.50
Total for Semi-machined Chuck Back fitted to Chuck and to Lathe.....	\$7.00	\$7.50	\$8.00	\$8.50	\$9.00	\$10.00
Code Word for Semi-machined Chuck Back fitted to Chuck and to Lathe.....	Efago	Eodar	Ender	Eldon	Eliza	Elsie

Drill Chucks for South Bend Lathes



Three-Jaw Drill Chuck

The geared sleeve and key enable this drill chuck to be easily operated with one hand and to assure a powerful grip. Prices include pinion key. Chuck arbor is not included in these prices.

Prices Three-Jaw Drill Chuck

Cat. No.	Capacity	Code Word	Price
1200	0 to 3/8 in.	Cleve	\$ 5.00
1201	0 to 1/2 in.	Wauko	8.50
1202	3/8 to 3/4 in.	Falao	14.00
1203	1/2 to 1 in.	Frank	18.50

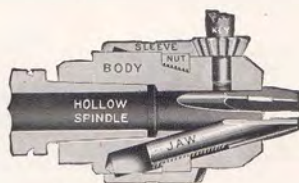

Hollow Spindle Drill Chuck

This is an ideal Chuck for the refacing of Valves that are not centered. The jaws grip the ground part of the valve stems for their full length at the point where the valve fits the valve guide. It is also ideal for holding small bar work.

Prices Hollow Spindle Drill Chuck

Cat No.	Capacity	Code Word	Price
1211	1/2 in.	Nedro	\$9.50
1212	5/8 in.	Nolan	9.50

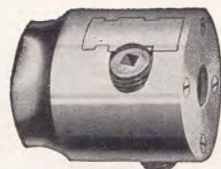

Two-Jaw Drill Chuck

A strong, simple chuck for straight shank drills, taps, reamers, etc. Jaws are tempered steel and operated by a heavy screw.

Prices Two-Jaw Drill Chuck

Cat. No.	Capacity	Code Word	Price
1300	3/8 in.	Oblig	\$ 8.50
1301	1/2 in.	Objec	10.00
1302	3/4 in.	Octav	11.50
1303	1 in.	Optio	15.00

Drill Chuck Prices do not include Spindles or Arbors.

Finished Drill Chuck Arbor



The steel Drill Chuck Arbor is used for fitting the Drill Chuck to the lathe. The short taper fits into socket of Drill Chuck and the long taper fits into the taper of both the headstock spindle and the tailstock spindle of the lathe.

When ordering Drill Chuck Arbor only, state size and make of Drill Chuck, diameter and depth of arbor socket, and size of lathe on which the chuck is to be used.

Prices Finished Drill Chuck Arbors

Solid Arbor				Hollow Arbor				
Size Lathe	Morse Taper	Cat. No.	Code Word	Price Arbor	Cat. No.	Morse Taper	Code Word	Price Arbor
9 in.	2	709	Abner	\$1.50	1223	3	Hilda	\$3.00
11 in.	2	709	Abner	1.50	1228	Special	Hoxal	4.00
13-15 in.	3	713	Adams	2.00	1223	3	Hilda	3.00
16-18 in.	3	716	Agate	2.00	1225	3	Hodge	3.00

The Solid Arbor must be ordered for the Three-Jaw Drill Chuck and Two-Jaw Drill Chuck; and the Hollow Arbor for the Hollow Spindle Drill Chuck as they are not interchangeable. Unless Arbor is ordered with chuck, a semi-finished Arbor fitted to Lathe Spindle only and not machined to fit Drill Chuck, will be furnished.

Patent Tool Holders for South Bend Lathes

Straight Shank Turning Tool



Drop Forged Steel
Price includes Wrench and one high speed Steel Cutting Bit.

Net Factory Prices

Size of Lathe, Inches	Catalog No.	Size of Shank, Inches	Size of Cutter, Inches	Code Word	Price Each
9	849-S	3/8 x 3/8	1/4 x 1/4	Azamm	\$2.40
11	851-S	3/8 x 7/8	1/4 x 1/4	Aybnm	2.55
13, 15	852-S	1/2 x 1 1/8	3/8 x 3/8	Axcol	3.00
16, 18	853-S	3/4 x 1 1/2	3/4 x 3/4	Awdpk	3.60

Left-Hand Off-Set Turning Tool



Drop Forged Steel
Price includes Wrench and one high speed Steel Cutting Bit.

Net Factory Prices

Size of Lathe, Inches	Catalog No.	Size of Shank, Inches	Size of Cutter, Inches	Code Word	Price Each
9	849-L	3/8 x 3/8	3/4 x 1/4	Aufri	\$2.40
11	851-L	3/8 x 7/8	3/4 x 1/4	Atgsh	2.55
13, 15	852-L	1/2 x 1 1/8	3/8 x 3/8	Asbtg	3.00
16, 18	853-L	3/4 x 1 1/2	3/4 x 3/4	Aruf	3.60

Right-Hand Off-Set Turning Tool



Drop Forged Steel
Price includes Wrench and one high speed Steel Cutting Bit.

Net Factory Prices

Size of Lathe, Inches	Catalog No.	Size of Shank, Inches	Size of Cutter, Inches	Code Word	Price Each
9	849-R	3/8 x 3/8	3/4 x 1/4	Apkwd	\$2.40
11	851-R	3/8 x 7/8	3/4 x 1/4	Aolxc	2.55
13, 15	852-R	1/2 x 1 1/8	3/8 x 3/8	Aumyb	3.00
16, 18	853-R	3/4 x 1 1/2	3/4 x 3/4	Amnza	3.60

Formed Threading Tool

Drop Forged Steel



Requires grinding on top only to sharpen. Price includes one Formed Cutter, V, U. S. S., or Whitworth Standard, Sharp V Cutter furnished unless otherwise ordered. Specify number of threads per inch wanted.

Net Factory Prices

Size of Lathe, Inches	Size Holder, Inches	Extra Cutters			Tool Complete		
		Catalog No.	Code Word	Price Each	Catalog No.	Code Word	Price Each
9	3/8 x 3/8	860	Akpbp	\$2.40	865	Afrgt	\$3.75
11	3/8 x 7/8	861	Ancex	2.40	866	Aeshs	3.75
13, 15	1/2 x 1 1/8	862	Airdw	2.85	867	Aditr	4.50
16, 18	3/4 x 1 1/2	863	Ahoex	3.75	868	Aeujq	5.75

Spring Threading Tool



Drop Forged Steel
Price includes Holder with Headless Cam, Lock Nut, finished high speed Steel Cutter and Hardened Wrench.

Net Factory Prices

Size of Lathe, Inches	Size Holder, Inches	Extra Cutters			Tool Complete		
		Catalog No.	Code Word	Price Each	Catalog No.	Code Word	Price Each
11	3/8 x 7/8	870	Avcgk	\$.40	873	Aefjn	\$3.75
13, 15	1/2 x 1 1/8	871	Azdbl	.50	874	Adgko	4.50
16, 18	3/4 x 1 1/2	872	Abeim	.65	875	Aeijq	5.75

High Speed Steel Cutter Bits for Turning Tools

Ground to Shape



A Left Hand Turning Tool "Adhlp"
B Round Nose Turning Tool "Aeimq"
C Right Hand Turning Tool "Afinr"
D Left Hand Turning Tool "Agkos"
E Thread- ing Tool "Ahlpt"
F Right Hand Side Tool "Aimqu"

Code words above indicate shape of the cutting edge.

Code words in table below indicate size of the cutter bit—use both code words when ordering.

The illustrations above show the cutting edge of six high speed steel hardened cutter bits, ground to shape, ready for use. This set of ground cutter bits covers the range of general lathe work, however, if other shapes of cutting edges are wanted the user may grind these bits as desired to suit the work that he has in hand. In using ground cutter bits it would be well for the operator to dress the cutting edge down with an oil stone. This increases the life of the cutting edge of the tool.

Net Factory Prices

Cat. No.	Size, Square Inches	Length Cutter, Inches	Approx. Wt. per Dozen, Pounds	Single Bits		Set of Six Bits	
				Code Word	Price Each	Code Word	Price Each
1304	1/4	2	1/4	Athex	\$.25	Asumd	\$1.50
1311	1/4	2 1/4	1/4	Akosv	.30	Aptxb	1.80
1313	5/8	2 1/2	1 1/4	Alptx	.45	Aquyc	2.70
1316	3/8	3	1 1/4	Amquy	.65	Arvzd	3.90
1321	1/8	3 1/2	2 3/4	Anrvz	1.00	Aswae	6.00

High Speed Steel Cutter Bits

Not Ground to Shape



The above illustration shows the hardened high speed steel cutter bit before the cutting edge is ground to shape. The operator can grind the cutter bits to shape to suit his work. These cutter bits are supplied in the various dimensions to fit the different size of tool holders for various size lathes. These high speed steel cutter bits are of the finest quality high speed steel and will give excellent service.

Net Factory Prices

Catalog No.	Size, Square Inches	Length Cutter, Inches	Wt. per Dozen, Pounds	Code Word	Price Each
1419	1/4	2	1/4	Atroc	\$.15
1421	1/4	2 1/4	3/4	Auycg	.20
1422	5/8	2 1/2	1 1/4	Avzdb	.35
1423	3/8	3	1 1/4	Awaei	.55
1424	1/8	3 1/2	2 3/4	Axbfj	.90

Spring Cutting-Off Tool

Drop Forged Steel



Price includes Wrench and one High Speed Steel Cutter Blade. Left-Hand Cutting-off Tools can be furnished at same prices.

Net Factory Prices

Size of Lathe, Inches	Size of Shank, Inches	Size of Cutter, Inches	Extra Cutter Blades		Tool Complete			
			Cat. No.	Code Word	Cat. No.	Code Word		
9-11	3/8 x 7/8	3/8 x 3/8	877-S	Acard	\$.60	811	Cadex	\$4.00
13-15	1/2 x 1 1/8	1/2 x 3/4	878-S	Adelt	.80	842	Camel	4.75
16-18	3/4 x 1 1/2	3/4 x 3/4	879-S	Aeropl	1.15	843	Candl	5.90

Patent Tool Holders for South Bend Lathes

Right-Hand Cutting-Off Tool Drop Forged Steel



Price includes Wrench and one High Speed Steel Cutter Blade.

Net Factory Prices

Size of Lathe, Inches	Size of Shank, Inches	Size of Cutter, Inches	Extra Cutter Blades			Tool Complete		
			Cat. No.	Code Word	Price Each	Cat. No.	Code Word	Price Each
9	5/8 x 3/4	3/8 x 1/2	876-R	Cabag	\$.55	881-R	Cheld	\$2.60
11	3/4 x 7/8	3/8 x 5/8	877-R	Cbent	.60	822-R	Cinom	2.75
13, 15	1/2 x 1 1/8	1/2 x 3/4	878-R	Cdart	.80	883-R	Clain	3.25
16, 18	3/4 x 1 1/2	1/2 x 7/8	879-R	Cecin	1.15	884-R	Cmolt	4.00

Left-Hand Cutting-Off Tool



Drop Forged Steel

Price includes Wrench and one High Speed Steel Cutter Blade.

Net Factory Prices

Size of Lathe, Inches	Size of Shank, Inches	Size of Cutter, Inches	Extra Cutter Blades			Tool Complete		
			Cat. No.	Code Word	Price Each	Cat. No.	Code Word	Price Each
9	5/8 x 3/4	3/8 x 1/2	876-L	Alcot	\$.55	881-L	Amay	\$2.60
11	3/4 x 7/8	3/8 x 5/8	877-L	Alern	.60	882-L	Anelm	2.75
13, 15	1/2 x 1 1/8	1/2 x 3/4	878-L	Arote	.80	883-L	Alrok	3.25
16, 18	3/4 x 1 1/2	1/2 x 7/8	879-L	Amenx	1.15	884-L	Alrok	4.00

Straight Cutting-Off Tool



Drop Forged Steel

Price includes Wrench and one High Speed Steel Cutter Blade.

Net Factory Prices

Size of Lathe, Inches	Size of Shank, Inches	Size of Cutter, Inches	Extra Cutter Blades			Tool Complete		
			Cat. No.	Code Word	Price Each	Cat. No.	Code Word	Price Each
9	5/8 x 3/4	3/8 x 1/2	876-S	Abser	\$.55	881-S	Agone	\$2.60
11	3/4 x 7/8	3/8 x 5/8	877-S	Acard	.60	882-S	Ahern	2.75
13, 15	1/2 x 1 1/8	1/2 x 3/4	878-S	Adelt	.80	883-S	Ajame	3.25
16, 18	3/4 x 1 1/2	1/2 x 7/8	879-S	Aerop	1.15	884-S	Akilt	4.00

Knurling Tool

Drop Forged Steel



Price includes Holder and one set of Knurls. Knurls can be furnished coarse, medium, and fine, in either Straight Line or Diamond pattern. Medium Diamond Knurls will be furnished unless otherwise specified.

Net Factory Prices

Size of Lathe, Inches	Size of Shank, Inches	Dimensions of Knurls, Inches			Extra Knurls			Tool Complete		
		Dia.	Face	Hole	Cat. No.	Code Word	Price Pair	Cat. No.	Code Word	Price Each
9	5/8 x 3/4	5/8	3/8	3/16	886	Dacos	\$.90	891	Dzelt	\$5.10
11	3/4 x 7/8	3/4	7/8	3/16	887	Dboot	.90	892	Dhapo	5.50
13, 15	1/2 x 1 1/8	1/2	1 1/8	3/16	888	Deram	1.00	893	Dilge	6.00
16, 18	3/4 x 1 1/2	3/4	1 1/2	3/16	889	Demon	1.00	894	Dloma	7.25



- Left-Hand Side Tool
- Right-Hand Side Tool
- Right-Hand Bent Tool
- Right-Hand Diamond Point
- Left-Hand Diamond Point
- Round Nose Tool
- Cutting-Off Tool
- Threading Tool
- Bent Threading Tool
- Round Tool
- Boring Tool
- Inside Threading Tool

Style "A" Boring Tool For Heavy Duty

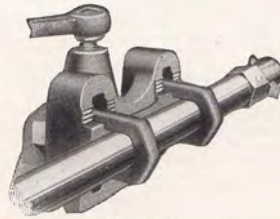

Fits regular tool post by removing tool post ring and wedge only. Cutter bit is adjustable and may be set either straight or at a 45-degree angle.

Price includes Holder, Boring Bar, Wrench and one High Speed Steel Cutter Bit.

Net Factory Prices

Size of Lathe, Inches	Size of Shank, Inches	Size of Bar, Inches	Size of Cutter, Inches	Extra Cutter Bits			Tool Complete		
				Cat. No.	Code Word	Price Each	Cat. No.	Code Word	Price Each
13, 15	1/2 x 1 1/8	1 1/4 x 1 1/2	3/8	451	Faded	\$.35	426	Faber	\$ 6.50
16, 18	3/4 x 1 1/2	1 1/2 x 1 1/2	7/8	452	Fedar	.55	427	Feast	8.50

Style "B" Boring Tool

For Medium Work



Made of Drop Forged Steel. Cutting tool can be set either straight or at a 45-degree angle. Price includes Holder, Bar, one End Cap, two Cutters, and two Wrenches.

Net Factory Prices

Size of Lathe, Inches	Holder Size, Inches	Size of Square, Inches	Stand and Bar Size, Inches	Extra Cutter Bits			Tool Complete		
				Cat. No.	Code Word	Price Each	Cat. No.	Code Word	Price Each
9	5/8 x 3/4	3/8	1/2	454	Hadie	\$.15	429	Habor	\$4.40
11	3/4 x 7/8	7/8	3/4	455	Hboya	.15	430	Hboya	4.40
13, 15	1/2 x 1 1/8	7/8	3/4	456	Helno	.20	431	Hcoil	5.25
16, 18	3/4 x 1 1/2	1 1/8	3/4	457	Hdzat	.35	432	Hideal	6.30

Style "C" Boring Tool

For Small Work

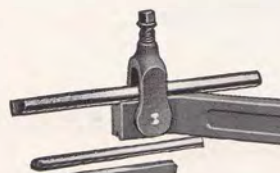

Made of Drop Forged Steel. Holder is reversible and can be used for right or left-hand work.

Price includes Holder, Wrench, two Boring Bars and one High Speed Cutter Bit.

Net Factory Prices

Size of Lathe, Inches	Size of Shank, Inches	Diameter of Bars, Inches	Size of Square, Inches	Extra Cutter Bits			Tool Complete		
				Cat. No.	Code Word	Price Each	Cat. No.	Code Word	Price Each
11	3/4 x 3/4	1/2 and 3/4	3/4	459	Ibok	\$.20	434	Ibexo	\$3.75
13, 15	1/2 x 1 1/8	3/4 and 1 1/8	3/4	460	Iferm	.35	435	Icole	4.75
16, 18	3/4 x 1 1/2	1/2 and 3/4	3/4	461	Itrat	.55	436	Ildavy	6.10

Hand Forged Lathe Tools—Carbon and High Speed Steel

Properly forged to shape, tempered and ground. Ready for use. If ordering less than one complete set, be sure to state both the tool number and set number.

Net Factory Prices

Size of Lathe, Inches	Size of Shank, Inches	Carbon Steel				High Speed Steel			
		Price		Set of 12		Price		Set of 12	
		Cat. No.	Price Each	Code Word	Price	Cat. No.	Price Each	Code Word	Price
9	5/8 x 3/4	438-C	\$.60	Jaelo	\$ 7.00	438-HS	\$ 2.00	Jaher	\$ 20.00
11	3/4 x 7/8	439-C	.70	Jbaux	8.00	439-HS	2.80	Jhrix	32.00
13, 15	1/2 x 1 1/8	440-C	1.20	Jecin	14.00	440-HS	4.20	Jipuv	50.00
15	3/4 x 1	443-C	1.60	Jdolv	19.00	443-HS	5.85	Jkeop	70.00
16, 18	3/4 x 1 1/2	441-C	2.00	Jerov	23.00	441-HS	7.20	Jleap	85.00

Lathe Dogs and Tools for South Bend Lathes

Standard and Safety Lathe Dogs



Furnished in two types—Standard or Safety. Made of heavy malleable iron and properly designed for strength and service. Prices include hardened steel set screw. A wrench is furnished for the headless set screw of Safety Lathe Dogs.

Net Factory Prices

Capacity of Lathe Dog	STANDARD LATHE DOGS			SAFETY LATHE DOGS		
	Catalog No.	Code Word	Price Each	Catalog No.	Code Word	Price Each
3/8 in.	1-M	Xaced	\$0.50	1-MH	Xamol	\$0.60
1/2 in.	2-M	Xcdfc	.60	2-MH	Xanpm	.70
5/8 in.	4-M	Xdefg	.70	4-MH	Xeonq	.85
1 in.	6-M	Xefgh	.80	6-MH	Xdpro	1.00
1 1/4 in.	8-M	Xfghi	.90	8-MH	Xeqsp	1.10
1 1/2 in.	10-M	Xghij	1.05	10-MH	Xfrtq	1.25
1 3/4 in.	11-M	Xhikl	1.15	11-MH	Xgsur	1.40
2 in.	12-M	Xijkl	1.30	12-MH	Xhtvs	1.55
2 1/4 in.	14-M	Xklmn	1.50	14-MH	Xiutw	1.85
3 in.	15-M	Xklmn	1.65	15-MH	Xjvxu	2.10
3 1/2 in.	16-M	Xlmop	1.85	16-MH	Xkwyv	2.25
4 in.	17-M	Xmnop	2.15	17-MH	Xlxyz	2.60

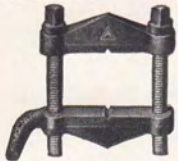

Clamp Lathe Dogs

Made of heavy drop forged steel, carefully machined and hardened. Very practical for holding rectangular work. Each dog is boxed separately.

Net Factory Prices

Catalog No.	Capacity Between Screws	Clamp Dog		Extra Screws	
		Code Word	Price Each	Code Word	Price Each
160	1 3/4 in.	Xxspi	\$3.00	Xotle	\$0.20
161	2 1/4 in.	Xtyqi	4.00	Xpump	.30
162	3 in.	Xuzrk	5.00	Xvngv	.40
163	3 1/2 in.	Xvasi	7.00	Xrwob	.60

Special Boring and Turning Tool

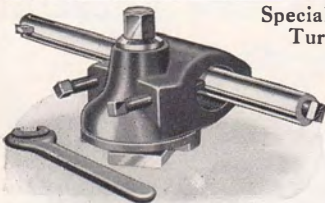

The special boring and turning tool is practical for truing brake drums of automobiles, buses and trucks. It is designed for turning large diameters and for heavy duty boring. Price in one high speed

cludes holder, boring bar, wrench and cutter bit.

Net Factory Prices

Size of Lathe	Diameter of Bar	Size of Cutter Bits	Tool Complete			Extra Cutter Bits		
			Cat. No.	Code Word	Price Each	Cat. No.	Code Word	Price Each
9"	3/4"	3/8"	469	Haxez	\$12.00	474	Hifer	\$0.25
11"	1"	3/8"	470	Hamed	14.00	475	Hiton	.65
13"	1 1/4"	3/8"	471	Hares	18.00	476	Hotey	1.00
15"	1 1/2"	3/8"	472	Hezok	22.00	477	Horor	1.10
16-18"	1 3/4"	3/8"	473	Hebox	23.00	478	Huzel	1.10
*No. 2	1 1/2"	3/8"	464-A	Hvrad	23.00	479	Huxit	1.60
*No. 3	1 3/4"	3/8"	465-A	Hindu	29.00	480	Huloz	2.20

*No. 2 and No. 3 are Brake Drum Lathes.

Morse Taper Reducing Sleeve



Made of steel and machined to Morse Standard Taper Gauges. Used in fitting small tapers to large sockets.

Net Factory Prices

Cat. No.	Size Morse Taper	Taper of Bore	Outside Taper	Code Word	Price Each
118-A	No. 1 to 2	No. 1 Morse	No. 2 Morse	Corse	\$0.90
118-B	No. 1 to 3	No. 1 Morse	No. 3 Morse	Cesor	1.20
118-C	No. 1 to 4	No. 1 Morse	No. 4 Morse	Cakun	1.50
118-D	No. 2 to 3	No. 2 Morse	No. 3 Morse	Clank	1.20
118-E	No. 2 to 4	No. 2 Morse	No. 4 Morse	Corap	1.50
118-F	No. 3 to 4	No. 3 Morse	No. 4 Morse	Carie	1.50

Combination Center Drill and Countersink



For drilling center hole and countersinking 60 degree angle for lathe center. Made of carbon tool steel, hardened and ground. Table shows correct size center drill for various sizes of work.

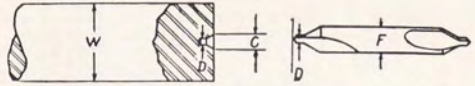

Net Factory Prices

Cat. No.	Diam. of Work "W"	Diam. of Countersink "C"	Diam. of Drill "D"	Body of Drill "F"	Code Word	Price Each	Code Word per Doz.	Price per Doz.
898-A	3/8" to 1"	3/8 in.	3/8 in.	3/8 in.	Xmqbl	\$0.25	Xapfa	\$2.25
898-B	3/8" to 1 1/2"	3/8 in.	3/8 in.	3/8 in.	Xnrhc	.30	Xkrogb	2.75
898-C	1 1/4" to 2"	3/8 in.	3/8 in.	3/8 in.	Xoskl	.40	Xsrhc	2.75
898-D	2 1/4" to 4"	3/8 in.	3/8 in.	3/8 in.	Xpoez	.30	Xtrfd	3.50

Center Gauge, No. 650

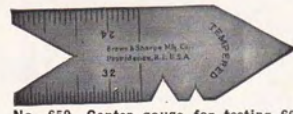

For testing the angle of 60 degree lathe centers. Also used in setting threading tools for cutting 60 degree "V" or U.S. Standard screw threads.

No. 650. Center gauge for testing 60 degree Lathe Centers. Net Factory price, each.....\$0.50
Code word Xutje.

Pipe Centers for Lathes

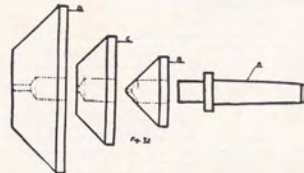

For machining pipe in the lathe. Taper Shank "A" fits either head spindle or tail spindle of lathe. The conical discs "B," "C," and "D" revolve on Taper Shank "A." Prices of discs larger than those listed furnished on request.

Net Factory Prices

ITEM	Catalog No.	Code Word	Price Each
Taper Shank "A" for 11" lathes	910-B	Xwbtm	\$ 3.00
Taper Shank "A" for 13", 15" lathes	910-C	Xacun	4.00
Taper Shank "A" for 16", 18" lathes	910-E	Xydo	4.50
Disc "B" takes from 1/2" to 3" pipe	911-B	Xafxq	6.00
Disc "C" takes from 3/8" to 5" pipe	912-C	Xceyr	8.00
Disc "D" takes from 5" to 8" pipe	913-D	Xdhzs	15.00

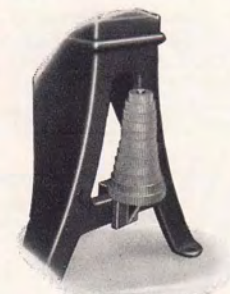

Gear Holding Bracket

This bracket is practical for holding the loose, independent change gears furnished with Standard Change Gear Lathes, floor leg type. The bracket is made of cast iron and fits over the cross bar between the legs under the headstock or tailstock. Made for floor leg lathes of all sizes.

Net Factory Prices

Size Lathe	9 in.	11 in.	13 in.	15 in.	16 in.	18 in.
Cat. No.	244	245	246	247	248	249
Code Word	Hulit	Hildun	Hoten	Hadey	Helad	Hifox
Price Each	\$3.00	\$3.50	\$3.50	\$5.00	\$5.00	\$5.00

Practical Chuck and Tool Assortments

Showing Prices of Assortment for Each Size New Model South Bend Lathe

Practical Chuck and Tool Assortment. Each Chuck and Tool Assortment listed here has the correct sizes of Chucks and proper Tools for all sizes of New Model South Bend Lathes in all the various types and drives. We recommend these Assortments as the most practical for general shop use. Any Assortment as described and priced may be ordered complete, or if preferred, you may order the desired items separately.

When ordering a complete Assortment give only the Catalog Number or Code Word of the Assortment wanted. When ordering items separately, give Catalog Number or Code Word of each item.

If a 3-Jaw Universal Lathe Chuck is wanted instead of a 4-Jaw Independent Lathe Chuck as listed in the Chuck and Tool Assortments below, affix a letter "A" to the Chuck and Tool Assortment number; for example, No. 122-A. Refer to page 64 and add the difference in price between the 4-Jaw Independent Lathe Chuck and the 3-Jaw Universal Lathe Chuck in the size you choose.

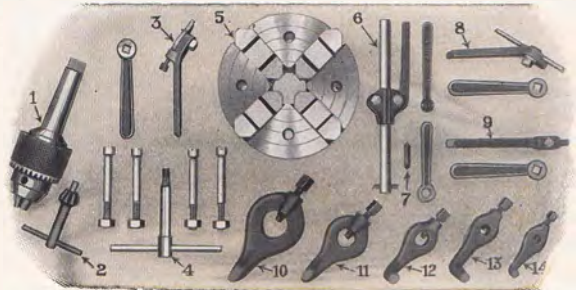

Practical Chuck and Tool Assortment illustrated above and described at left is itemized below and applies to all sizes of South Bend Lathes, differing only in dimensions for each size lathe.

No. 122 Chuck and Tool Assortment for 9-inch Junior Lathes

1 No. 2106	6-inch, 4-Jaw Independent Lathe Chuck.	\$28.00
	Fitting Chuck to Lathe including Chuck Back	7.00
1 No. 1201	3-Jaw Drill Chuck, 1/2-inch capacity	8.50
1 No. 709	Drill Chuck Arbor, fitted to Chuck	1.50
1 No. 849-S	Patent Turning Tool, straight shank	2.40
1 No. 865	Patent Boring Tool	3.75
1 No. 429	Patent Boring Tool, Style B	4.40
1 No. 881-R	Patent Cutting Off Tool (Right Hand)	2.60
1 Set (5)	Malleable Lathe Dogs, 1/2", 3/4", 1", 1 1/4", 1 1/2"	4.05

Net Factory Price (Code Word Balor).....\$62.20

No. 109 Chuck and Tool Assortment for 9-inch Lathes

1 No. 2106	6-inch, 4-Jaw Independent Lathe Chuck.	\$28.00
	Fitting Chuck to Lathe including Chuck Back	7.00
1 No. 1201	3-Jaw Drill Chuck, 1/2-inch capacity	8.50
1 No. 709	Drill Chuck Arbor, fitted to Chuck	1.50
1 No. 849-S	Patent Turning Tool, straight shank	2.40
1 No. 865	Patent Threading Tool	3.75
1 No. 429	Patent Boring Tool, Style B	4.40
1 No. 881-R	Patent Cutting Off Tool (Right Hand)	2.60
1 Set (5)	Malleable Lathe Dogs, 1/2", 3/4", 1", 1 1/4", 1 1/2"	4.05

Net Factory Price (Code Word Celot).....\$62.20

No. 111 Chuck and Tool Assortment for 11-inch Lathes

1 No. 2106	6-inch, 4-Jaw Independent Lathe Chuck.	\$28.00
	Fitting Chuck to Lathe including Chuck Back	7.50
1 No. 1201	3-Jaw Drill Chuck, 1/2-inch capacity	8.50
1 No. 709	Drill Chuck Arbor, fitted to Chuck	1.50
1 No. 851-S	Patent Turning Tool, straight shank	2.55
1 No. 866	Patent Threading Tool	3.75
1 No. 430	Patent Turning Tool, Style B	4.40
1 No. 822-R	Patent Cutting Off Tool (Right Hand)	2.75
1 Set (5)	Malleable Lathe Dogs, 1/2", 3/4", 1", 1 1/4", 1 1/2"	4.05

Net Factory Price (Code Word Denob).....\$63.00

No. 113 Chuck and Tool Assortment for 13-inch Lathes

1 No. 2108	8-inch, 4-Jaw Independent Lathe Chuck.	\$32.00
	Fitting Chuck to Lathe including Chuck Back	8.00
1 No. 1201	3-Jaw Drill Chuck, 3/8-inch capacity	8.50
1 No. 713	Drill Chuck Arbor, fitted to Chuck	2.00
1 No. 852-S	Patent Turning Tool, straight shank	3.00
1 No. 867	Patent Threading Tool	4.50
1 No. 431	Patent Boring Tool, Style B	5.25
1 No. 883-R	Patent Cutting Off Tool (Right Hand)	3.25
1 Set (5)	Malleable Lathe Dogs, 1/2", 3/4", 1", 1 1/2", 2"	4.45

Net Factory Price (Code Word Enbal).....\$70.95

1. 3-Jaw Drill Chuck with Arbor Attached
2. Pinion Key for Drill Chuck
3. Formed Threading Tool and Wrench
4. Wrench and Cap Screws for Lathe Chuck
5. 4-Jaw Independent Lathe Chuck
6. Style "B" Patent Boring Tool and Wrenches
7. High Speed Steel Cutter Bits
8. Right Hand Patent Cutting-Off Tool and Wrench
9. Straight Shank Patent Turning Tool and Wrench

10, 11, 12, 13, 14. Are Malleable Lathe Dogs, 1/2-inch, 3/4-inch, 1-inch, 1 1/4-inch and 1 1/2-inch capacity.

No. 115 Chuck and Tool Assortment for 15-inch Lathes

1 No. 2109	9-inch, 4-Jaw Independent Lathe Chuck.	\$35.00
	Fitting Chuck to Lathe including Chuck Back	8.50
1 No. 1303	2-Jaw Drill Chuck, 1-inch capacity	15.00
1 No. 713	Drill Chuck Arbor, fitted to Chuck	2.00
1 No. 852-S	Patent Turning Tool, straight shank	3.00
1 No. 867	Patent Threading Tool	4.50
1 No. 431	Patent Boring Tool, Style B	5.25
1 No. 883-R	Patent Cutting Off Tool (Right Hand)	3.25
1 Set (5)	Malleable Lathe Dogs, 1/2", 3/4", 1", 1 1/4", 2"	4.45

Net Factory Price (Code Word Goreb).....\$80.95

No. 116 Chuck and Tool Assortment for 16-inch Lathes

1 No. 2110	10-inch, 4-Jaw Independent Lathe Chuck.	\$40.00
	Fitting Chuck to Lathe including Chuck Back	9.00
1 No. 1303	2-Jaw Drill Chuck, 1-inch capacity	15.00
1 No. 716	Drill Chuck Arbor, fitted to Chuck	2.00
1 No. 853-S	Patent Turning Tool, straight shank	3.60
1 No. 868	Patent Threading Tool	5.75
1 No. 432	Patent Boring Tool, Style B	6.90
1 No. 884-R	Patent Cutting Off Tool (Right Hand)	4.00
1 Set (5)	Malleable Lathe Dogs, 1/2", 3/4", 1", 1 1/2", 2"	4.45

Net Factory Price (Code Word Margo).....\$90.70

No. 118 Chuck and Tool Assortment for 18-inch Lathes

1 No. 2112	12-inch, 4-Jaw Independent Lathe Chuck.	\$48.00
	Fitting Chuck to Lathe including Chuck Back	10.00
1 No. 1303	2-Jaw Drill Chuck, 1-inch capacity	15.00
1 No. 716	Drill Chuck Arbor, fitted to Chuck	2.00
1 No. 853-S	Patent Turning Tool, straight shank	3.60
1 No. 868	Patent Threading Tool	5.75
1 No. 432	Patent Boring Tool, Style B	6.90
1 No. 884-R	Patent Cutting Off Tool (Right Hand)	4.00
1 Set (5)	Malleable Lathe Dogs, 1/2", 1 1/2", 2", 2 1/2", 3"	6.20

Net Factory Price (Code Word Somer).....\$101.45

Hard Maple Bench with Drawer



This bench may be used with all types of 9-inch and 11-inch bench lathes.

The bench illustrated is made of fine quality hard maple. Benches are shipped knocked down to save freight charges. Bolts are furnished for assembling bench. If you wish to make your own bench, we will supply the blue prints of detail drawings of benches.

Above—Design of bench 72" and larger. 54" bench does not have center leg

60 Degree Head Spindle Lathe Center



Made of tool steel, accurately ground all over. For use in headstock spindle of the lathe. Not hardened.

Net Factory Prices

Size of Lathe	9 in.	11 in.	13 in.	15 in.	16 in.	18 in.
Cat. No.	725A	725B	725C	725D	725E	725F
Code Word ..	Abest	Actor	Aders	Aegan	Afire	Arzem
Price	\$2.00	\$2.25	\$2.75	\$2.75	\$2.75	\$2.75

60 Degree Tail Spindle Lathe Center



Made of tool steel, hardened and ground all over. For use in tailstock spindle of the lathe.

Net Factory Prices

Size of Lathe	9 in.	11 in.	13 in.	15 in.	16 in.	18 in.
Cat. No.	726A	726B	726C	726D	726E	726F
Code Word ..	Caten	Cella	Cheat	Clena	Clase	Cotin
Price	\$2.25	\$2.50	\$3.00	\$3.00	\$3.00	\$3.00

Spur Center



Size Lathe	Cat. No.	Code Word	Net Price
9 in.	732A	Ibeck	\$3.00
11 in.	732B	Icons	3.00
13 in.	732C	Idols	4.00
15 in.	732D	Iguan	4.00
16 in.	732E	Ilong	4.00
18 in.	732F	Ikarf	4.00

Cup Center



Size Lathe	Cat. No.	Code Word	Net Price
9 in.	733A	Jacks	\$3.00
11 in.	733B	Jealt	3.00
13 in.	733C	Jiped	4.00
15 in.	733D	Jober	4.00
16 in.	733E	Juvin	4.00
18 in.	733F	Jvale	4.00

Screw Center

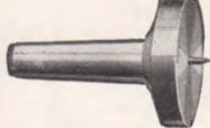

Size Lathe	Cat. No.	Code Word	Net Price
9 in.	731A	Kabar	\$3.50
11 in.	731B	Kelso	3.50
13 in.	731C	Kinty	4.00
15 in.	731D	Klink	4.00
16 in.	731E	Koden	4.00
18 in.	731F	Kring	4.00

Crotch Center



Size Lathe	Cat. No.	Code Word	Net Price
9 in.	728A	Faint	\$3.00
11 in.	728B	Fever	3.00
13 in.	728C	Plats	4.00
15 in.	728D	Flota	4.00
16 in.	728E	Found	4.00
18 in.	728F	Frail	4.00

Drill Pad



Size Lathe	Cat. No.	Code Word	Net Price
9 in.	727A	Dabed	\$3.00
11 in.	727B	Dears	3.00
13 in.	727C	Dingy	4.00
15 in.	727D	Dopet	4.00
16 in.	727E	Drunk	4.00
18 in.	727F	Dumbe	4.00

Specifications and Prices of Benches

Length Bench Top	Width Bench Top	Length of Lathe Bed, Feet	Code Word	Cat. No.	Price
54 in.	32 in.	2½ to 3½	Cakes	128-X	\$45.00
72 in.	32 in.	4 to 5	Cedar	128-A	50.00
60 in.	*40 in.	2½ to 4	Chock	128-H	55.00
72 in.	*40 in.	4½ to 5	Cords	128-J	60.00
96 in.	*40 in.	5½	Color	128-G	80.00

*Benches with top 40 inches wide required for 11-inch Self-Contained, Horizontal and Combination Motor Driven Lathes.

Standards for Simplex Motor Drive Bench Lathes

The Countershaft Standards illustrated are used to support the Maple Cross Board. These Standards are painted and drilled ready to mount on bench.



Cross Board
No. 20-B Cross Board only. Code Word "Churn"\$1.00
No. 20-I Standards, per pair, drilled. Code Word "Cider".....\$12.50



Extra Equipment for 9-inch Junior Lathes



Double Gear Bracket for 9-inch Lathes

With the double bracket it is possible to cut a greater variety of finer pitch threads than can be cut with the regular bracket furnished with the 9-inch Lathes.

No. 1050. Code Word "Fames." Price\$15.00



The Large Face Plate is threaded and fitted to the spindle nose of the lathe.

No. 40 Large Face Plate. Code Word, "Cryed." Price\$10.00

No. 40

Center Rest supports long, slender work while being machined.

No. 125 Center Rest. Code Word, "Clift." Price...\$10.00



No. 130



No. 125

Follower Rest travels with the cutting tool, and supports long, slender work, while being machined.

No. 130 Follower Rest. Code Word, "Culve." Price\$6.00

Adjustable Thread Cutting Stop is used for regulating depth of chip in thread cutting.

No. 67 Threading Stop, Code Word, "Cobra." Price\$2.50

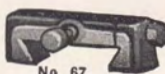

No. 67

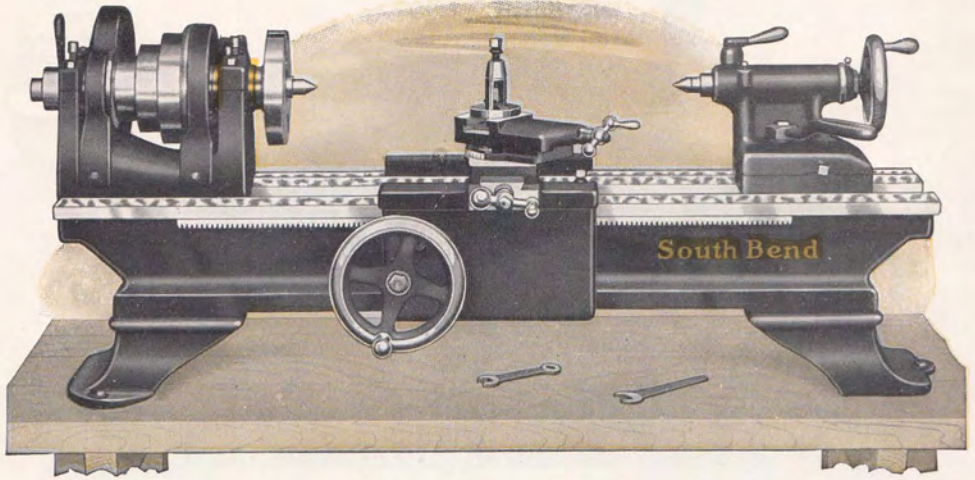

9-inch South Bend Special Metal Turning Lathe

Back Geared Precision Bench Lathe—Countershaft Drive

The 9-inch No. 20 Special Back Geared Metal Turning Lathe is assembled from the units of our regular 9-inch Junior Lathe, the same Headstock, Spindle, Tailstock and Bed—all are identical on the No. 20 Lathe with those of the 9-inch Junior Lathe. The same accuracy, hand scraping and inspection that our regular lathes receive is also given to the No. 20 Lathe.

Using the Regular Units of the 9-inch Junior Lathe and by omitting units that are not always necessary with a lathe of this type such as the Lead Screw, the Thread Cutting Feature, etc., also the Large Face Plate, Follower Rest, Center Rest and Thread Cutting Stop from the equipment and by using a Tight and Loose Pulley Countershaft, makes it possible to set a price of \$120.00 and up on the 9-inch Special Metal Turning Lathe.

The 9-inch Special Lathe is Practical for machining metals of all kinds, such as wrought iron, steel, cast iron, brass, copper, bronze and aluminum. It also can be used for the working of wood, hard rubber, fiber, etc., or for the finest precision work.

Types of Motor Drive. The 9-inch Special Metal Turning Lathe can be equipped with Simplex Drive, Self-Contained Drive, Silent Chain Drive and Horizontal Drive, the same as shown with the 9-inch Junior Lathe. For illustrations and descriptions of these types of motor drive refer to pages 44-48. Prices on application.

LATHE FEATURES

- Back geared headstock gives 6 spindle speeds.
- Hollow spindle, made of special carbon steel.
- Phosphor bronze bearings for spindle.
- Graduated compound rest swivels to any angle.
- Tailstock is arranged for set-over for taper turning.
- Graduated collar on cross feed and compound rest screws.
- Hand wheel longitudinal feed.
- Ball crank cross feed.
- Sturdy carriage handscrapped to outer "V"-ways.
- Heavy, reinforced lathe bed, 3 "V"-ways and one flat way.

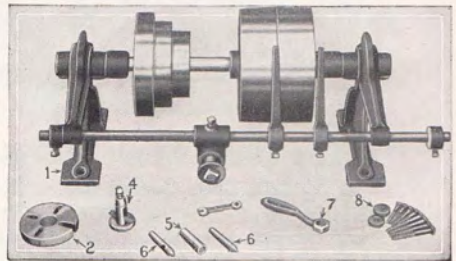

Countershaft and Equipment Illustrated Above Is Included in the Price of the Lathe

The Lathe Equipment included in the price of each 9-inch Special Metal Turning Lathe is illustrated above and consists of: Tight and Loose Pulley Countershaft, Compound Rest, two Steel Lathe Centers (No. 2 Morse Taper), a Spindle Sleeve, Small Face Plate, Tool Post, Ring and Wedge, Wrenches and Lag Screws for fastening the Lathe and Countershaft. Also Erection Plans, Floor Plans and book, "How to Run a Lathe."

Compound Rest on the 9-inch No. 20 Special Metal Turning Lathe is graduated 180 degrees and can be clamped to operate at any angle required. Feed Screw has Micrometer Collar reading in thousandths of an inch.

LATHE SPECIFICATIONS

Head and Tail Spindle Centers.....	No. 2, Morse Taper
Size of Spindle Nose.....	1/2 in. diam., 8 threads
Width of Cone Pulley Belt.....	1 in.
Spindle Speeds.....	45, 75, 130, 246, 410, 701 R.P.M.
Countershaft Speed.....	300 R.P.M.
Countershaft Friction Clutch Pulleys.....	6 1/2 in. x 2 3/8 in.
Angular Travel of Compound Rest Top.....	17 1/2 in.
Size of Lathe Tool Shank.....	3/2 in. x 1 1/8 in.
Travel of Tailstock Spindle.....	2 1/4 in.
Tailstock Set-over.....	3/4 in.

Easy Payment Prices 9-inch Special Metal Turning Lathe Including Overhead Countershaft and Equipment

No. of Lathe	Swing Over Bed	Length of Bed	Between Centers	Hole Thru Spindle	Swing Over Carriage	Power Required	Weight Crated	Code Word	Price F.O.B. South Bend	Down Payment 20%	12 Equal Monthly Payments
20-XC	9 1/2 in.	2 1/2 ft.	11 in.	3/4 in.	6 3/8 in.	1/4 H.P.	285 lbs.	Bmira	\$120.00	\$24.00	\$8.40
20-YC	9 1/2 in.	3 ft.	18 in.	3/4 in.	6 3/8 in.	1/4 H.P.	310 lbs.	Bocks	126.00	25.20	8.82

If Floor Legs are wanted instead of Short Legs, add \$10.00.
Monthly Payments include carrying charge.

SOUTH BEND, INDIANA, U. S. A.

1. Testing
2. Truing
3. Balancing
4. Machining
Brake Drums
and Wheels

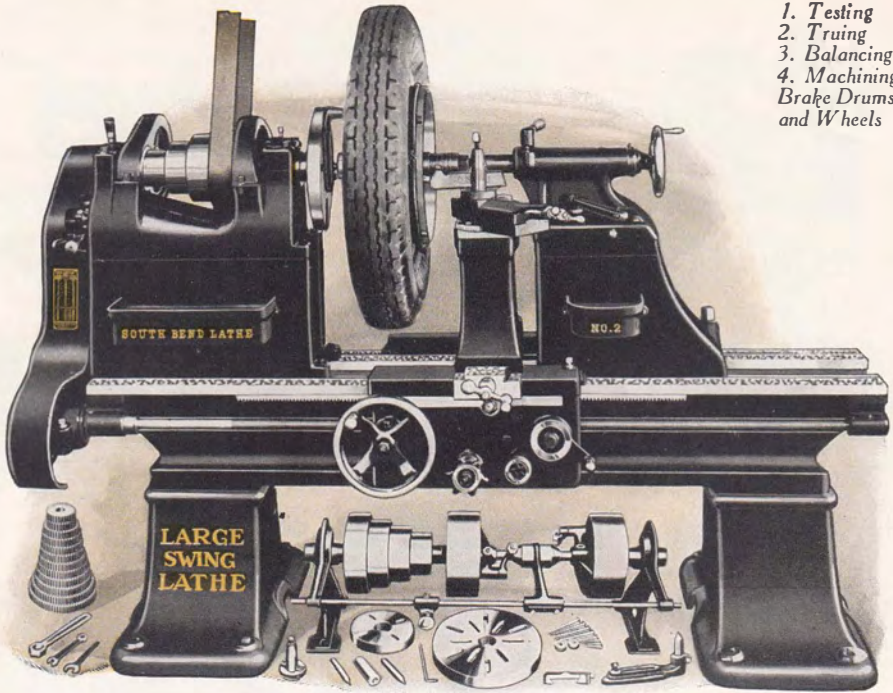

Countershaft and Equipment Included in Price of Lathe

The New Model South Bend Brake Drum Lathe

A Modern Back Geared Screw Cutting Precision Tool—Countershaft Drive

For Truing Brake Drums, Machining Auto Wheels and General Manufacturing Work

The No. 2 Brake Drum Lathe will swing a wheel, with tire attached, up to 36¼ inches in diameter. It is a back geared screw cutting precision lathe for truing brake drums, refacing hubs and servicing auto wheels of all types and makes, front and rear, single or dual, which includes the wheels of all pleasure cars, buses and medium size trucks. The average time to true the brake drum of an automobile or medium size truck on the No. 2 Brake Drum Lathe is from 5 to 12 minutes, depending on the width of drum.

The No. 3 Brake Drum Lathe will swing a wheel with tire attached up to 42¼ inches in diameter. The average time required to true a brake drum of a large bus or heavy duty truck on the No. 3 Brake Drum Lathe is 15 to 20 minutes.

FEATURES OF BRAKE DRUM LATHE

Back geared headstock gives 8 spindle speeds.
Automatic cross feed, automatic longitudinal feed.
Independent change gears for threads and feeds.
Hollow spindle made of special carbon steel.
Phosphor bronze bearings scraped to spindle.
Graduated Compound rest swivels to any angle.
Precision lead screw for cutting accurate threads.
Self-centering mandrel and adapter method.

The Self-Centering Mandrel and Adapter Method is the correct, accurate and most economical method for truing brake drums, refacing hubs and machining wheels. The wheel mounted on the self-centering mandrel (fitted with adapters) between centers on the lathe permits machining the brake drum concentric with the axis of the hub.

For the Service Station that services automobiles, medium size buses and trucks, where the tire diameter does not exceed 36¼ inches, the No. 2 Brake Drum Lathe is the practical size. It is also an excellent general purpose lathe for machine shop work.

Lathe Equipment included in the price of the Brake Drum Lathe consists of: Double Friction Countershaft, Large Face Plate, Small Face Plate, Driver for Auto Wheels, Graduated Compound Rest, Tool Post, Ring and Wedge, Thread Cutting Stop, Two Lathe Centers, Spindle Sleeve, Rubber Belts and Springs, Wrenches and a Set of Independent Change Gears for Cutting Standard Screw Threads and for operating the Automatic Feeds.

Mandrels and Adapters are extra. See page 74.

Easy Payment Prices of Brake Drum Lathes Including Overhead Countershaft and Equipment

Catalog No. of Lathe	Swings Wheel, Tire Attached Clear	Length of Bed	Distance Between Centers	Hole Thru Spindle	Counter-shaft Speed	Horse Power Required	Approx. Weight Crated	Code Word	Price F. O. B. South Bend	Down Payment 20%	12 Equal Monthly Payments
No. 2 South Bend Brake Drum Lathe—Countershaft Drive											
2-BC	36¼ in.	6 ft.	27 in.	1¾ in.	150 R.P.M.	1 H.P.	2160 lbs.	Cocoa	\$688.00	\$137.60	\$48.16
2-BD	36¼ in.	7 ft.	39 in.	1¾ in.	150 R.P.M.	1 H.P.	2240 lbs.	Carro	709.00	141.80	49.63
2-BE	36¼ in.	8 ft.	51 in.	1¾ in.	150 R.P.M.	1 H.P.	2320 lbs.	Cuxom	730.00	146.00	51.10
2-BG	36¼ in.	10 ft.	75 in.	1¾ in.	150 R.P.M.	1 H.P.	2480 lbs.	Chlar	776.00	155.20	54.32
No. 3 South Bend Brake Drum Lathe—Countershaft Drive											
3-BE	42¼ in.	8 ft.	38 in.	1¾ in.	125 R.P.M.	3 H.P.	4650 lbs.	Daisy	\$1470.00	\$294.00	\$102.90
3-BG	42¼ in.	10 ft.	62 in.	1¾ in.	125 R.P.M.	3 H.P.	4900 lbs.	Debar	1552.00	310.40	108.64
3-BH	42¼ in.	12 ft.	86 in.	1¾ in.	125 R.P.M.	3 H.P.	5300 lbs.	Doubt	1659.00	331.80	116.13

Quick Change Gear Box is extra. For No. 2 Lathe add \$80.00 to above prices, for No. 3 Lathe add \$120.00.
Write for 24-page Bulletin No. 29 illustrating and describing the Brake Drum Lathe and the work it does.
Monthly Payments include carrying charge.

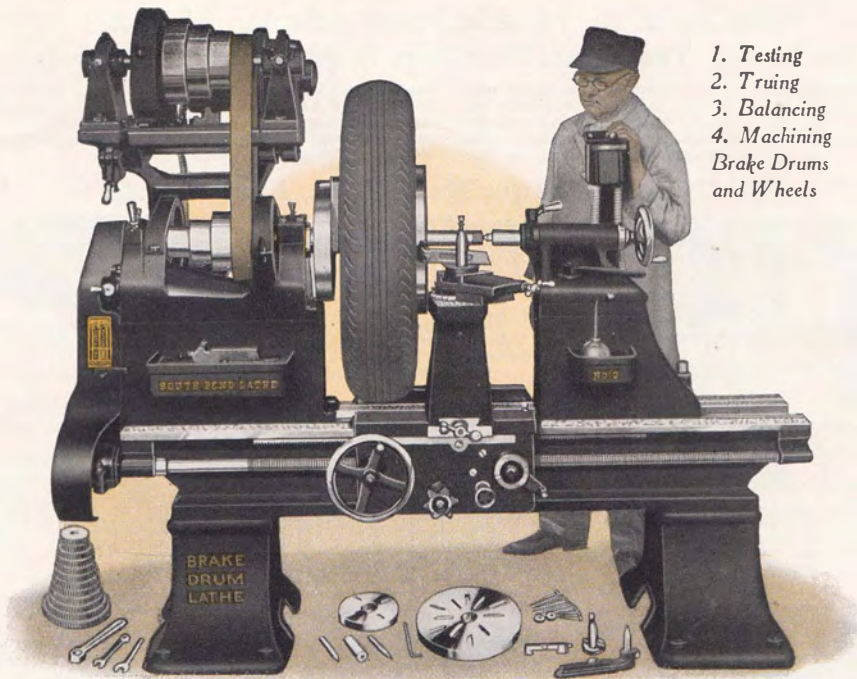

1. Testing
2. Truing
3. Balancing
4. Machining
Brake Drums
and Wheels

Reversing Motor, Reversing Switch and Lathe Equipment Are Included in Price

Silent Chain Motor Driven Brake Drum Lathe

A Modern Back Geared Screw Cutting Precision Tool

For Truing Brake Drums, Machining Auto Wheels and General Manufacturing Work

The Silent Chain Motor Driven Brake Drum Lathe is the same as the Brake Drum Lathe shown on page 72, except that this Lathe is Motor Driven instead of Countershaft Driven. The Lathe is a complete unit requiring no extra Driving equipment of any kind, and has eight spindle speeds. The Motor delivers power through the Silent Chain to the Driving Cone. This drive is a most practical method of driving a Screw Cutting Lathe as it is powerful and eliminates vibration and noise. See pages 28 and 29.

The Constant Speed Reversing Motor, 1200 R.P.M., enables the operator to start, stop and reverse the lathe spindle quickly.

The Drum Type Reversing Switch is the most practical switch for the efficient operation of a screw cutting lathe. It is mounted on the tail-stock of the lathe and enables the operator to control the starting, stopping and reversing of the lathe spindle from a convenient working position in front of lathe.

Motor Specifications. When ordering a Motor Driven Brake Drum Lathe, specify the electric current to be used.

- If alternating current, state exact voltage, phase, cycle and number of wires.
- If direct current, state voltage only.

Electrical Equipment Included with the Motor Driven Brake Drum Lathes consists of: a Reversing Motor 1200 R.P.M., Reversing Switch, Wiring between Motor and Switch, Flexible Metal Conduit, Wiring Diagram and Leather Belt.

Lathe Equipment Included with each Silent Chain Motor Driven Brake Drum Lathe consists of: Graduated Compound Rest, Large and Small Face Plates, Adjustable Driver for Wheel, Tool Post Complete, Thread Cutting Stop, Two Lathe Centers, Spindle Sleeve, Rubber Belts and Springs, Wrenches, and Change Gears for cutting Screw Threads 2 to 40 per inch and for Automatic Feeds.

Mandrels and Adapters are not included in price of Lathe but are extra. See page 74.

Easy Payment Prices of Silent Chain Motor Driven Brake Drum Lathes Prices Include Lathe Equipment, 1200 R.P.M. Reversing Motor, Reversing Switch and Leather Belt

Catalog No. of Lathe	Swings Wheel, Tire Attached Clear	Length of Bed	Horse Power Required	Approx. Weight Crated	Code Word	With 3 Phase, 60 Cycle A.C. Motor			With 1 Phase, 60 Cycle A.C. Motor			With Direct Current Motor		
						Price F.O.B. S. Bend	Down Payment 20%	12 Equal Monthly Payments	Price F.O.B. S. Bend	Down Payment 20%	12 Equal Monthly Payments	Price F.O.B. S. Bend	Down Payment 20%	12 Equal Monthly Payments
No. 302 Silent Chain Motor Driven Brake Drum Lathe														
302-BC	36 1/4 in.	6 ft.	1 H.P.	2585 lbs.	Clanch	\$867.00	\$173.40	\$60.69	\$896.00	\$179.20	\$62.72	\$ 945.00	\$189.00	\$66.15
302-BD	36 1/4 in.	7 ft.	1 H.P.	2665 lbs.	Coast	888.00	177.60	62.16	917.00	183.40	64.19	986.00	193.20	67.62
302-BE	36 1/4 in.	8 ft.	1 H.P.	2745 lbs.	Croze	909.00	181.80	63.63	938.00	187.60	65.66	987.00	197.40	69.09
302-BG	36 1/4 in.	10 ft.	1 H.P.	2905 lbs.	Cudex	955.00	191.00	66.85	984.00	196.80	68.88	1033.00	206.60	72.31
No. 303 Silent Chain Motor Driven Brake Drum Lathe														
303-BE	42 1/4 in.	8 ft.	3 H.P.	5525 lbs.	Dawdy	\$1855.00	\$371.00	\$129.85	\$1926.00	\$385.20	\$134.82	\$1989.00	\$397.80	\$139.23
303-BG	42 1/4 in.	10 ft.	3 H.P.	5775 lbs.	Ducat	1937.00	387.40	135.59	2008.00	401.60	140.56	2071.00	414.20	144.97
303-BH	42 1/4 in.	12 ft.	3 H.P.	6175 lbs.	Drive	2044.00	408.80	143.08	2115.00	423.00	148.05	2178.00	435.60	152.46

Monthly Payments include carrying charge. Write for Bulletin No. 29 on the Brake Drum Lathe.

Self-Centering Mandrel and Adapter Method

For Truing, Testing and Machining Brake Drums and Wheels

The South Bend Self-Centering Mandrels and Bearing Adapters will take care of practically all front wheels, rear wheels, single and dual wheels for testing the wheels and for machining brake drums of all types—internal expanding and ex-

ternal contracting, two-wheel and four-wheel brakes and band brakes—on all types and makes of wheels for automobiles, buses and trucks. The mandrel and adapter method is illustrated and described below.

Self-Centering Straight Mandrels for Front Wheels

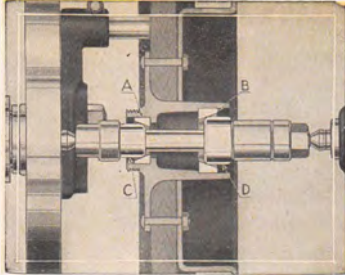

Timken Races and Universal Bearing Adapters
A front wheel with Timken roller races, mounted on the mandrel fitted with universal bearing adapters, between centers in the lathe ready for testing or machining.



The self-centering straight mandrel will take care of all front and full-floating rear wheels (mounted on ball or roller bearings). Its ends are hardened to retain accurate centers. The mandrel is fitted with adjustable collars for use with the various types of bearing adapters allowing wheels of all widths to be mounted on the mandrel. The threaded nut presses the bearing adapters against the bearing cups of the hub making it line up accurately.

Specifications and Prices of Straight Mandrels for Front Wheels

Catalog Number	Diameter of Mandrel	Length of Mandrel	For All Adapters with	Code Word	Price Each
1800	1 1/4 in.	12 in.	1 1/4-in. hole	Narde	\$15.00
1810	1 3/4 in.	18 in.	1 3/4-in. hole	Nlsae	25.00
1840	2 1/2 in.	26 in.	2 1/2-in. hole	Nizel	40.00

Universal Bearing Adapters for Front Wheels

The illustration shows a pair of universal bearing adapters made of steel, used on the self-centering straight mandrels for mounting all types and makes of front wheels, and rear wheels with three-quarter and full-floating axles. The rounded corner of the universal bearing adapter conforms to the curve in the ball race cup and also to the angle of the Timken cup and will center either type of wheel accurately on the mandrel.

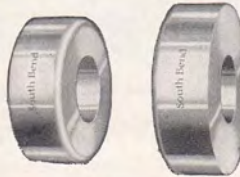

Specifications and Prices of Universal Bearing Adapters

Catalog Number	To Fit Mandrel	Diameters Furnished	Diameter of Adapter Hole	Code Word	Price Per Pair*
1801	No. 1800	1 5/8" to 3 3/4" in eighths	1 1/4 in.	Nefas	\$ 5.00
1811	No. 1810	2 1/8" to 4 3/4" in quarters	1 3/4 in.	Negel	6.00
1841	No. 1840	3 3/8" to 7" in quarters	2 1/2 in.	Narug	10.00

*Specify Catalog Number and Diameter of Adapters wanted when ordering.

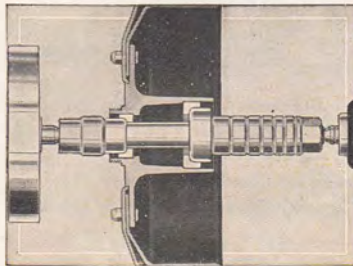

Ball Bearing Races and Universal Bearing Adapters

A front wheel with ball bearing races, mounted on the mandrel fitted with universal bearing adapters held between centers.

Self-Centering Taper Mandrels for Rear Wheels

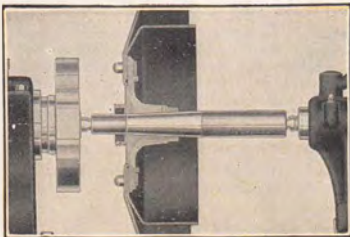

Set up of a rear wheel fitted with a taper mandrel, mounted between centers in the lathe for testing and machining.

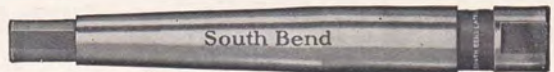

The self-centering taper mandrel illustrated above is used for mounting semi-floating rear wheels (mounted on a taper) between centers in the lathe for testing, truing or machining brake drums and wheels. This mandrel is made in five sizes to fit the hubs of rear wheels of automobiles, buses and trucks.

Specifications and Prices of Steel Taper Mandrels for Rear Wheels

Catalog Number	Diameter of Mandrel	Length of Mandrel	Taper Per Foot	Code Word	Price Each
1820	1" to 1 3/8"	13 1/2 in.	3/4 in.	Numbe	\$8.00
1821	3/4" to 1 1/4"	11 1/2 in.	1 in.	Novel	8.00
1822	1" to 1 1/2"	13 1/2 in.	1 in.	Nasim	9.00
1823	1 1/4" to 1 3/4"	15 in.	1 in.	Nough	9.50
1824	1 1/2" to 1 7/8"	11 1/2 in.	1 1/2 in.	Nuper	8.00

How to Select the Correct Mandrels and Adapters

For Servicing the Wheels of Any Model or Make of Automobile, Bus or Truck

Brake Drum Bulletin No. 29 lists the makes and models of automobiles, buses and trucks, also the year in which they were built. Opposite the name of each vehicle is shown the correct size and type of self-centering mandrels and universal bearing adapters to use for mounting the wheels between centers in the South Bend Brake Drum Lathe.

Two assortments of mandrels and adapters recommended for general brake service work are shown in this catalog (90-A) on page 75. Assortment No. 1 will service 17 makes and 45 models of automobiles, light buses and trucks. Assortment No. 2 will take care of 42 models of trucks and buses.

Write for 24-page Bulletin No. 29 illustrating and describing the Brake Drum Lathe and the work it does.

Machining Jobs on the South Bend Brake Drum Lathe On Wheels, Brakes, Brake Drums, Flanges and Hub Assemblies

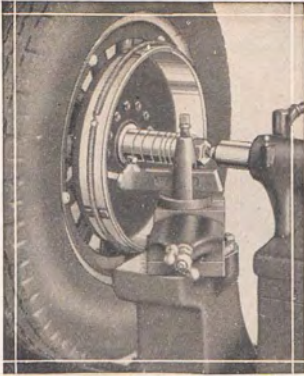

Truing an Internal Brake Drum mounted on a self-centering straight mandrel with universal bearing adapters mounted between centers in the lathe. Drum size 17 inches.

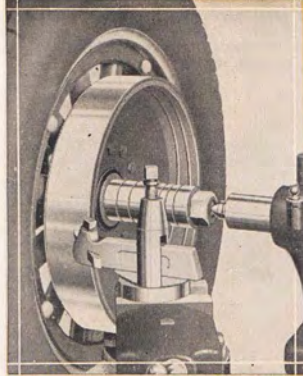

Truing an External Band Brake Drum mounted on a self-centering straight mandrel with universal bearing adapters between centers in the Brake Drum Lathe.

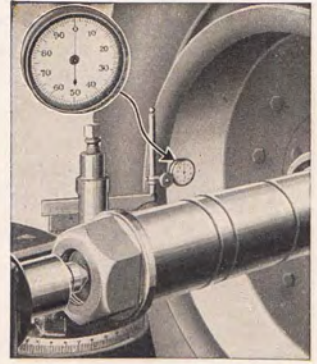

Testing the Brake Drum with a dial test indicator. The wheel is mounted on a self-centering mandrel and mounted between centers in the New Model South Bend Brake Drum Lathe.

Average Time for Truing a Brake Drum

The average time required to true the Brake Drum of an automobile or medium size truck on the No. 2 or No. 302 Brake Drum Lathes is from 5 to 12 minutes, depending on the width of drum.

The average time required to true the Brake Drum of a large bus or heavy duty truck on the No. 3 or No. 303 Brake Drum Lathes is from 15 to 20 minutes, depending on the width of drum.

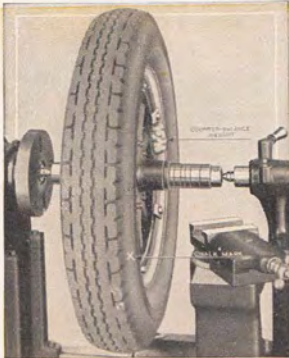

Balancing an Automobile Wheel. The automobile wheel can be balanced between centers in the South Bend Brake Drum Lathe with tire attached as shown in the above illustration.

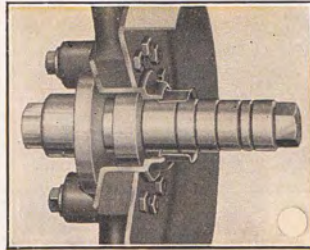

Face Plate and Annular Adapter

The face plate and annular adapter method is used for mounting rear wheels fitted with annular ball bearings used on Buick, Chandler, LaSalle, Willys-Knight, etc. The wheel is mounted on the self-centering mandrel and centered by the annular adapter. For more complete information and prices see No. 29 Brake Drum Bulletin.

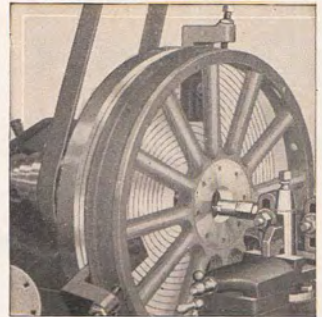

Boring a Wood Wheel. The wheel is mounted in a 3-jaw Universal Wheel Chuck. The hub can be fitted to the hole without removing the wheel from the lathe.

Wheel Chuck Price on Request.

Recommended Mandrel and Adapter Equipments

Assortment No. 1

Two Taper Mandrels, One Straight Mandrel and Eight Adapters Service 45 Models

The following three self-centering mandrels and eight universal bearing adapters will service 17 makes and 45 models of automobiles, light buses and trucks.

1—No. 1822 Taper Mandrel	\$ 9.00
1—No. 1823 Taper Mandrel	9.50
1—No. 1800 Straight Mandrel	15.00
8—No. 1801 Universal Bearing Adapters:	
1 1/8" dia., 1 7/8" dia., 2" dia., 2 1/4" dia.,	
2 3/8" dia., 2 1/2" dia., 2 5/8" dia., 2 7/8" dia.,	20.00
Total	\$53.50

Assortment No. 2

Two Straight Mandrels, One Taper Mandrel and Four Adapters Service 42 Models

The following three self-centering mandrels and four universal bearing adapters will service 42 models of trucks.

1—No. 1810 Straight Mandrel	\$25.00
1—No. 1840 Straight Mandrel	40.00
1—No. 1826 Taper Mandrel	12.00
2—No. 1811 Universal Bearing Adapters:	
2 1/2" dia., 3" dia.	6.00
2—No. 1841 Universal Bearing Adapters:	
4 1/4" dia., 4 1/2" dia.	10.00
Total	\$93.00

Write for 24-page Bulletin No. 29 illustrating and describing the Brake Drum Lathe and the work it does.

Manufacturing Jobs Machined on Brake Drum Lathes

Production Work, Tool Work and Pattern Work

The South Bend Brake Drum Lathe is practical for a wide variety of manufacturing jobs. It is now used by many manufacturers on production work, tool work, pattern work and other work

where a large swing lathe is required. Shown below are illustrations of a few jobs being machined on the New Model South Bend Brake Drum Lathe.

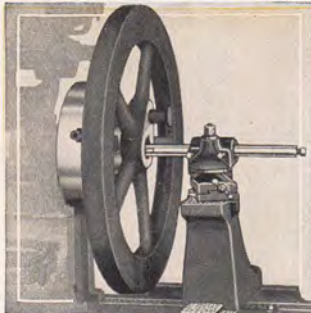

Boring a Large Flywheel

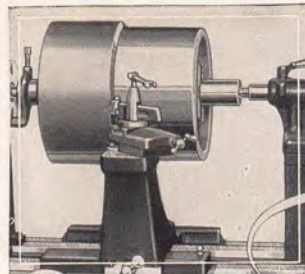

Making a Large Cast Iron Pulley in the Brake Drum Lathe

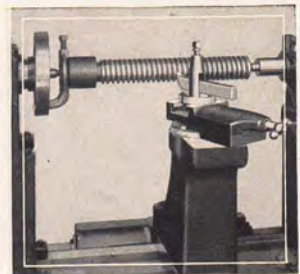

Cutting Screw Thread on a Jack Screw

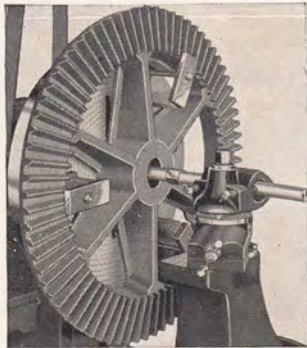

Boring Hole in a Large Bevel Gear Held in Wheel Chuck

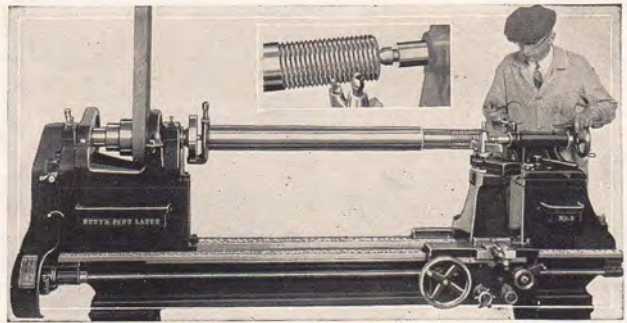

Cutting Screw Thread on a Shaft 3 1/2" Diam. x 4' Long. Inset Shows Tool Taking Cut

Machining Flywheels for Ring Gears

One Operator Can Machine and Fit from 20 to 25 Flywheels for Ring Gears in Eight Hours

The machining of flywheels for ring gears is practical on the No. 2, No. 302, No. 3 and No. 303 South Bend New Model Brake Drum Lathes which are described on pages 72 and 73.

The illustration at left shows a No. 2 lathe in operation machining a flywheel, removing the teeth, then turning the diameter to the correct size for fitting the ring gear. After removing the teeth the shoulder on the flywheel should be larger in diameter than the inside of the steel ring gear so there will be an ample seat.

This job shows the general utility of the South Bend Brake Drum Lathe for work in the service station, the electrical shop and the machine shop where large work is to be handled. It has the precision and accuracy so necessary in automotive and electrical work.

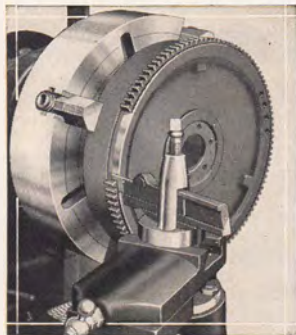

Accessories, Tools and Attachments for South Bend Brake Drum Lathes

Name of Tool, Accessory or Attachment	For No. 2 and No. 302 Lathes				For No. 3 and No. 303 Lathes			
	Cat. No.	Size	Code Word	Price	Cat. No.	Size	Code Word	Price
Special Boring Bar Complete.....	464-A	1 1/2 in.	Hvrad	\$23.00	465-A	1 1/2 in.	Hindu	\$29.00
Right-hand Patent Turning Tool (extra long)	855-R	3/4 x 1 3/8 in.	Quker	5.50	856-R	3/4 x 1 3/8 in.	Quzas	7.00
Left-hand Patent Turning Tool (extra long)	855-L	3/4 x 1 3/8 in.	Qutih	5.50	856-L	3/4 x 1 3/8 in.	Qofet	7.00
Center Rest	181	Noath	25.00	182	Noise	35.00
Follower Rest	186	Nysta	12.50	187	Niche	17.50

Write for 24-page Bulletin No. 29 illustrating and describing the Brake Drum Lathe and the work it does.

Self-Centering Piston Adapters for South Bend Lathes

For Finishing All Types and Sizes of Pistons on the Lathe



A Cross Section of a Piston on Adapter Ready for Machining

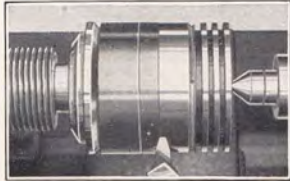

Machining a Piston to Finished Diameter

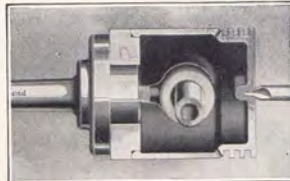

Centering a Piston Using Step Ring and Driving Dog, Type B



Alloy Split Piston Mounted on Adapter with Knife Edge Ring



Close Up Showing Knife Edge Ring on Adapter Holding Split Skirt Piston (Aluminum or Alloy) for Finish Machining in Lathe. Details in Book No. 66. See page 94



Reaming the Bevel Skirt of a Warped Piston so That It Will Fit True on the Adapter

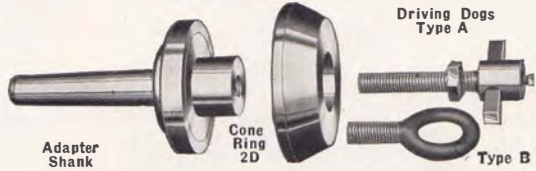

No. 44 Self-Centering Piston Adapter

The No. 44 Self-Centering Piston Adapter Shank with one cone ring and two driving dogs, Type A and Type B, is shown above. One end of the adapter shank is tapered to fit the lathe spindle. The other end is machined to receive the adapter rings. The driving dog screws into the threaded hole in the end of the adapter shank and may be adjusted to drive any piston. Type A Driving Dog is used for pistons with center hole in head, the Type B Driving Dog for pistons without center hole in head. This Piston Adapter Shank, fitted with the correct type of adapter rings, will hold all sizes, all makes and all types of oversize and semi-machined pistons for machining in the lathe.

Prices Below Include one No. 44 Self-Centering Piston Adapter Shank, one Ring (any size or type selected by customer), and one Driving Dog, Type A. One Adapter Ring, No. 2D, is furnished with the adapter unless otherwise specified. Extra Adapter Rings are supplied as shown below.

Prices of No. 44 Self-Centering Piston Adapters

Size Lathe	Morse Taper of Shank	Cat. No.	Code Word	Price Complete with shank, one driving dog, Type A, and one cone ring any size or type	Extra Driving Dog, Type B
9 in.	3	44-A	Hanov	\$12.00	\$0.50
11 in.	Special	44-B	Hbiol	12.00	.50
13 in.	3	44-C	Hclaw	12.00	.50
15 in.	3	44-D	Hdixe	13.00	.50
16 in.	3	44-E	Heota	13.00	.50

Types of Adapter Rings Furnished



The Adapter Rings shown above are used on the one No. 44 Self-Centering Piston Adapter Shank as they are all interchangeable. Specifications of all types of adapter rings are shown in the tabulation below.

Cone Rings No. 1, 2, 3, and 4 for holding pistons with center hole in head. Cone Rings are finish machined and tapered in a 60 degree angle. One ring will hold and center many sizes of pistons.

Step Rings No. 1, 2, 3, and 4 are for holding pistons without center hole in head. Step Rings are rough turned on outside diameter. The step must be machined to size desired.

Knife Edge Rings No. 1, 2, 3, and 4 are for holding split skirt pistons, aluminum or alloy. These Rings are rough turned on the outside diameter. The knife edge and the step must be machined to size desired.

Net Factory Prices and Specifications of Adapter Rings

Extra Cone Rings			Extra Step Rings			Extra Knife Edge Rings			Capacity of Adapter Rings (All Types)
Cone Ring No.	Code Word	Price, Extra Rings	Step Ring No.	Code Word	Price, Extra Rings	Knife Ring No.	Code Word	Price, Extra Rings	For Pistons Outside Diameter
1D	Hudso	\$2.50	1C	Halex	\$2.50	1K	Hedof	\$2.50	2½ to 3¼ in.
2D	Iiwaki	2.50	2C	Hafoal	2.50	2K	Himol	2.50	3¼ to 3⅞ in.
3D	Hyena	2.50	3C	Herim	2.50	3K	Hlzak	2.50	3⅞ to 4¼ in.
4D	Hzuge	2.50	4C	Hecot	2.50	4K	Hakon	2.50	4¼ to 5¼ in.

Piston Skirt Reamers

The Piston Reamers illustrated at the left are used on the No. 44 Piston Adapter Shank. The holes in the cone rings and the Reamers are the same size.

Prices of Piston Skirt Reamers

Reamer Number	For Pistons Outside Dia.	Code Word	Price, Each Reamer
1R	2½ to 3¼ in.	Hacke	\$ 7 50
2R	3¼ to 3⅞ in.	Heine	9.00
3R	3⅞ to 4¼ in.	Hiley	11.00
4R	4¼ to 5 in.	Holer	13.00

Electric Mica Undercutter

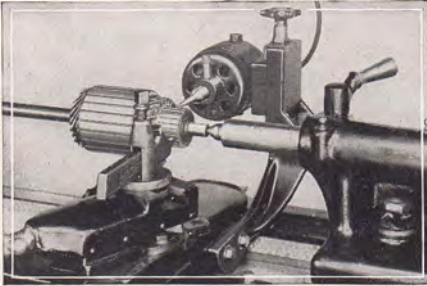

The Electric Mica Undercutter is practical for relieving mica insulation between segments of various size commutators, it is bolted to the saddle of the lathe and does not interfere with the turning tool when truing the commutator.

Price includes Motor, Bracket, Bolts for mounting on lathe and one set of 20 Disc Cutters (3/4 inch in diameter, 4 each—.015 in., .020 in., .025 in., .035 in.). When ordering specify either 110-volt or 220-volt current motor.

Net Factory Prices of Electric Mica Undercutter

Size of Lathe	Electric Undercutter with One Set of 20 Cutters			Extra Sets 20 Disc Cutters		
	Cat. No.	Code Word	Price Each	Cat. No.	Code Word	Price Per Set
9 in.	527	Quner	\$50.00	201-C	Imork	\$6.00
11 in.	528	Qagin	50.00	201-C	Imork	6.00

Shaper Mica Undercutter

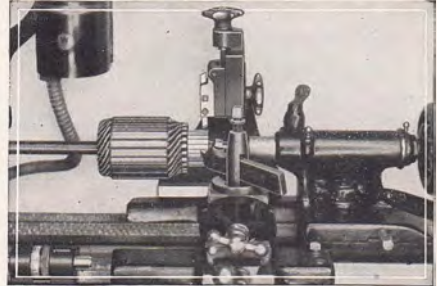

The Shaper Type Mica Undercutter is practical for relieving mica insulation between segments of commutators. It is attached to a frame and fastens to the back of the lathe carriage out of the way of the turning tool. The commutator may be trued and the mica undercut without removing the armature from the lathe. Vertical adjustment of tool is obtained through the knob at top.

Price includes Frame, one Cutter Bit and Bolts for mounting on back of lathe carriage.

Net Factory Prices of Shaper Type Mica Undercutter

Size Lathe	Shaper Undercutter with One Cutter Bit			Extra Cutter Bits		
	Cat. No.	Code Word	Price Each	Cat. No.	Code Word	Price Each
9 in.	526-A	Nados	\$30.00	202-C	Nilos	\$0.50
11 in.	526-B	Nibad	30.00	202-D	Noble	.50

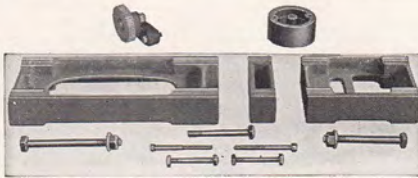

Raising Blocks for Lathes

Raising Blocks can be supplied for Straight Bed and Gap Bed Lathes in the Quick Change Gear and Standard Change Gear types to increase the swing of the lathe for power turning feeds and cutting screw threads. The table below shows the increased swing of the various lathes, when equipped with Raising Blocks. The Silent Chain Motor Driven Lathes cannot be fitted with Raising Blocks.

PRICES OF RAISING BLOCKS FOR STRAIGHT AND GAP BED LATHES

Straight Bed Lathes		Gap Bed Lathes		Raising Blocks for Quick Change Gear Lathes			Raising Blocks for Standard Change Gear Lathes		
Swing Over Bed	Swing Over Bed with Raising Blocks	Swing Over Gap	Swing Over Gap with Raising Blocks	Catalog No.	Code Word	*Price	Catalog No.	Code Word	*Price
9 1/4 in.	12 in.	1121	Cafer	\$ 35.00	1001	Caerie	\$ 30.00
11 1/4 in.	14 in.	1122	Cearre	41.00	1002	Cebro	35.00
13 1/4 in.	18 in.	1123	Charl	60.00	1003	Chlink	50.00
15 1/4 in.	20 in.	1124	Cilov	72.00	1004	Citus	60.00
16 1/4 in.	22 in.	1125	Click	84.00	1005	Claro	70.00
18 1/4 in.	24 in.	1126	Coger	96.00	1006	Cobil	80.00

GEAR GUARDS

For Lathes with Raising Blocks		
Size of Lathe	Cat. No.	Price
9 in.	1121-A	\$ 4.00
11 in.	1122-A	5.00
13 in.	1123-A	6.50
15 in.	1124-A	7.50
16 in.	1125-A	8.50
18 in.	1126-A	10.00

*Gear Guards for Lathes fitted with Raising Blocks are extra, see tabulation above on "Gear Guards."

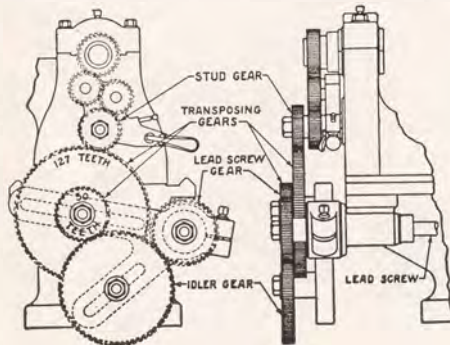

Transposing Gears for Cutting Metric Threads On New Model South Bend Lathes, Quick Change and Standard Change

To cut metric threads in addition to English threads on a Standard Change Gear or Quick Change Gear Lathe a set of transposing gears and a special bracket are required. Included in the set is a large gear having 127 teeth and a small gear having 50 teeth as shown in the illustration at left. The 127-tooth gear meshes with the stud gear and the 50-tooth gear connects with the idler, which in turn meshes with the lead screw gear.

South Bend Standard Change Gear Lathes may be equipped with a Metric Lead Screw instead of an English Lead Screw, at extra cost, if desired. Prices on application.

No. 15 Electric Grinder For South Bend Lathes

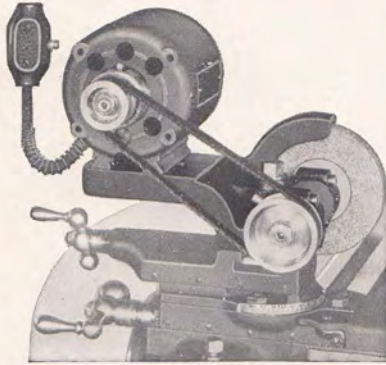

The No. 15 Electric Grinder is practical for grinding straight, taper or spiral reamers, milling cutters, taps, dies, valves, pistons, steel bushings, hardened shafts, etc.

The No. 15 Electric Grinder operates from an electric light socket. No special installation of electrical service is necessary. Specify electric current when ordering—if DIRECT current give voltage, if ALTERNATING current, give voltage, phase and cycle. The prices below include the No. 15 Electric Grinder with one Grinding Wheel and Clamp for mounting to Compound Rest.

Net Factory Prices of No. 15 Electric Grinder

Catalog Number	Size of Lathe	Size Emery Wheel	Outside Diameter Will Grind	Size Motor	Code Word	Price Each
15-I	9 in.	4 in. x ¾ in.	4¾ in.	¼ H.P.	Caret	\$75.00
15-J	11 in.	4 in. x ¾ in.	7¾ in.	¼ H.P.	Celts	75.00
15-K	13 in.	5 in. x ¾ in.	9 in.	½ H.P.	Chums	90.00
15-L	15 in.	5 in. x ¾ in.	10½ in.	½ H.P.	Cinch	90.00
15-M	16 in.	5 in. x ¾ in.	11 in.	½ H.P.	Clove	90.00
15-N	18 in.	5 in. x ¾ in.	12½ in.	½ H.P.	Coats	90.00

Prices of Internal Electric Grinder on request.

Different Grades of Grinding Wheels are needed for different classes of grinding work. Satisfactory results cannot be obtained from using the same wheel on all kinds of metals. Order the grinding wheels you need from the following table, or state the nature of your work and correct wheels will be shipped. Only one wheel is included in price of grinder.

Grade of Wheel for Various Metals

Metal	Name of Wheel	Grain	Grade
Steel	Alundum	46	M
Aluminum	Shellac	46	3
Valves	Shellac	60	3
Tools	Alundum	19	50-K
Cast Iron	Crystalon	36	K

Hand Rest for Wood Turning



For irregular work and Pattern making. The hand rest clamps directly to the ways of the bed. Price includes hand rest complete with two "T" rests and clamp for attaching.

Net Factory Prices

Size Lathe	Cat. No.	Code Word	Price
9 in.	1071	Vanda	\$10.50
11 in.	1072	Vapor	10.50
13 in.	1073	Varle	11.00
15 in.	1074	Venom	11.50
16 in.	1075	Vetix	12.00
18 in.	1076	Views	13.00

Adjustable Holding Fixture For Truing Grinding Wheels



The No. 19 Holding Fixture will hold the industrial diamond for truing wheels, and will also hold the cutter stop.

The illustration at the left shows how the Adjustable Holding Fixture clamps directly to the bed of the lathe, so that the carriage has free movement both when truing the grinding wheel and sharpening reamers and cutters.

A grinding wheel should be trued up frequently so that the cutting surface will run true.

Each part of the Holding Fixture may be purchased individually if desired or as a complete unit.

Net Factory Prices of Holding Fixture

Size of Lathe	Cat. No.	Code Word	Price Each
9 in.	19	Quenc	\$ 8.00
11 in.	19B	Quarz	9.00
13 in.	19C	Quest	10.00
15 in.	19D	Quick	12.00
16 in.	19E	Quirt	13.00
18 in.	19F	Quota	15.00

Industrial Diamond Dresser

No. 18 Industrial Diamond, Special Metal Mount ½ Carat. Price each (Code word "Quaft") . . . \$8.00

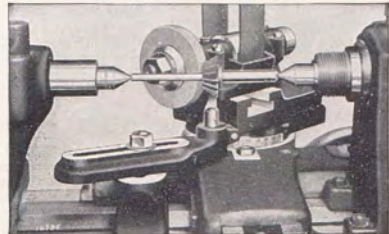

Grinding an Angular Cutter

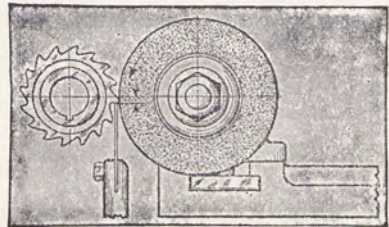

Grinding Clearance on a Cutter

Hand Lever Tailstock for 9-inch Lathes



This attachment is a quick acting arrangement to speed up drilling when drill chuck is held in the tailstock, as the spindle may be advanced or withdrawn by moving the hand lever in either direction. It is especially practical for quantity centering and drilling jobs and is constructed so that either the hand lever or hand wheel may be used. Must be fitted to lathe at factory.

No. 900. Code Word, "Jiden." Price. . . . \$35.00

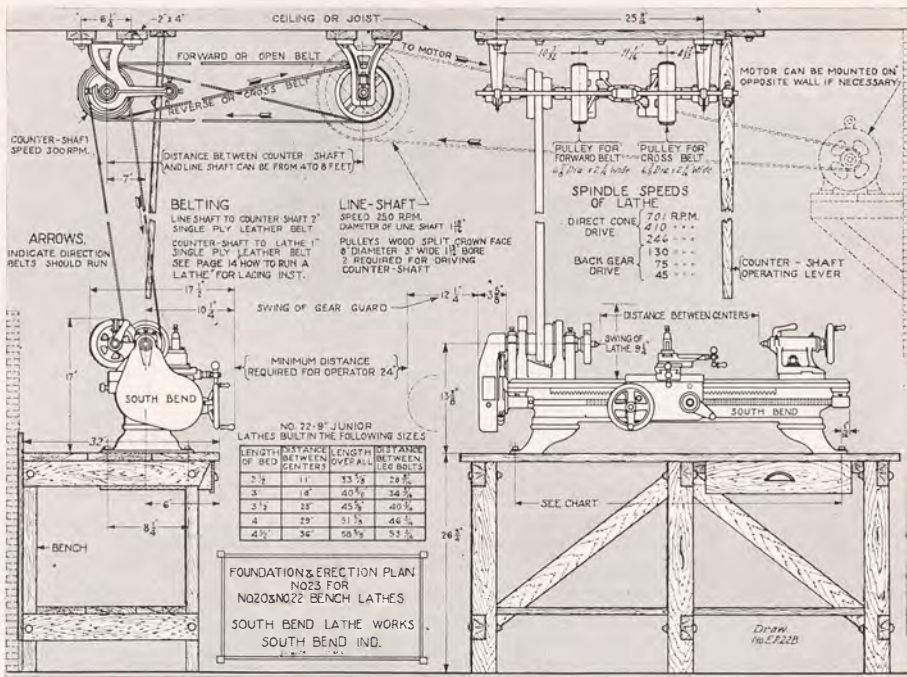

Erection Plan for Bench Lathes

The illustration above shows a reproduction of the Foundation and Erection Plan giving all necessary information for installing the 9-inch South Bend Bench Lathe. A 12x18-inch Blue Print similar to the above illustration is furnished with each size South Bend Bench Lathe.

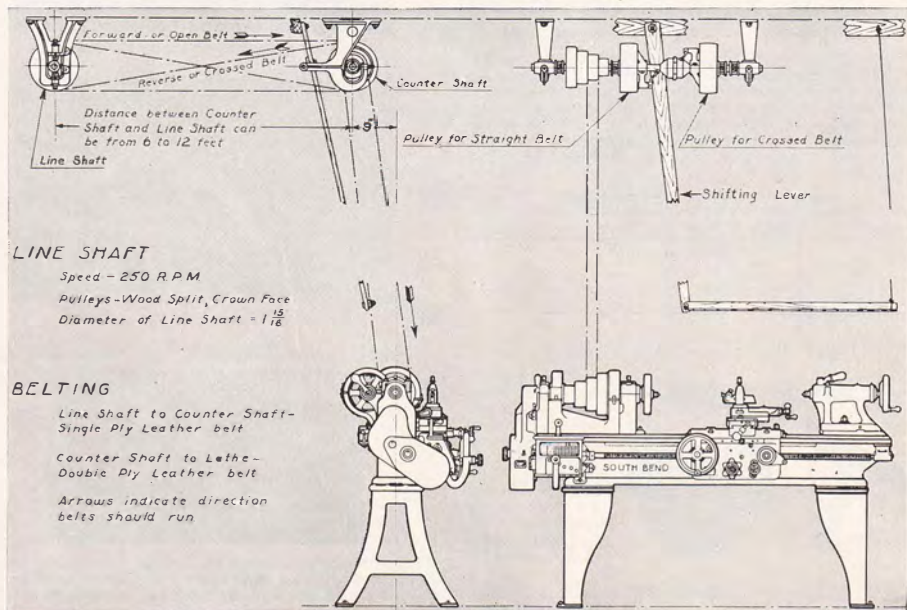

Erection Plan for Countershaft Driven Lathes

The illustration above shows a reproduction of the Foundation and Erection Plan giving all necessary information for installing a South Bend Floor Leg Lathe. A 12x18-inch Blue Print similar to the above illustration is furnished with each size South Bend Floor Leg Lathe.

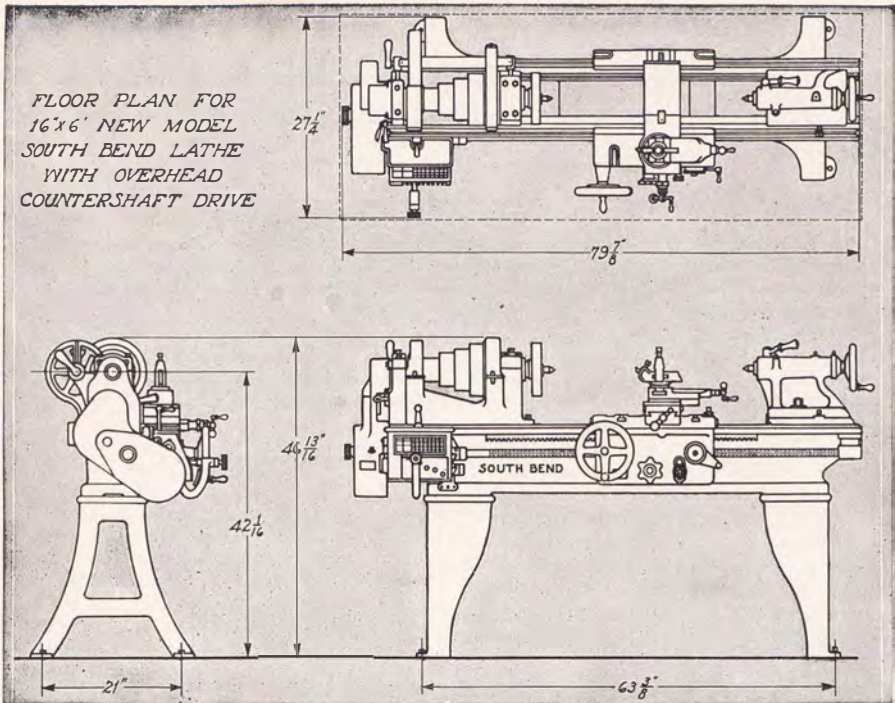

16-inch New Model South Bend Lathe with Overhead Countershaft Drive

Floor Plan for the New Model South Bend Lathe

The above drawing shows the floor plan of the 16-inch x 6-foot New Model South Bend Lathe with overhead countershaft drive. The view shown at the upper right of drawing indicates the amount of floor space this lathe will occupy when installed.

A blue print 12x18 inches is furnished with each size lathe showing the distance from the floor to the center line of the lathe and the height over all. It also shows the distance between bolt holes in the floor legs for fastening the lathe to the floor.

South Bend Lathes Are Carefully Packed for Shipment

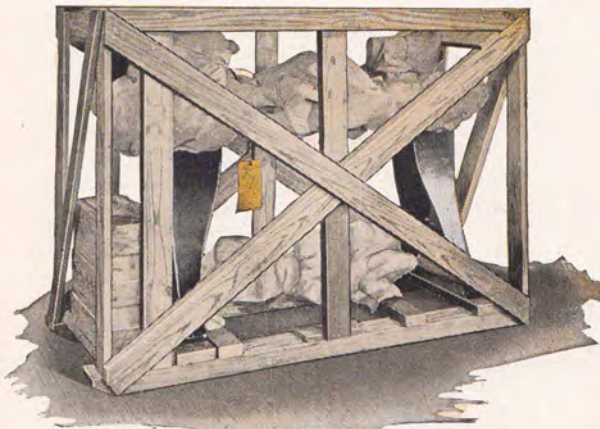

Lathe Crated for Domestic Shipment

Lathes for domestic shipment are not knocked down but are crated and shipped completely assembled. All that is necessary on arrival is to remove the crating and wrapping and install the lathe in its proper place.

Lathe Crated for Rail Shipment

The illustration at left shows a New Model South Bend 16-inch Lathe skidded and crated for domestic shipment, that is, by rail to any point in the United States, Canada and Northern Mexico. In preparing lathes for shipment all polished parts are greased to prevent rusting, each unit is wrapped securely with heavy paper so as to prevent dust or dirt accumulating in the mechanism.

The small parts are packed in a strong box which is nailed to the skids. The lathe is then skidded and crated so it will ride without damage.

Safe Arrival of Lathe Guaranteed

We have shipped more than 44,000 South Bend Lathes during the past 23 years and owing to the practical method of packing and crating we can guarantee the safe arrival of your lathe, and protect you against any loss or damage while in transit.

THE NEW 1929 EASY PAYMENT PLAN

For the Purchase of South Bend Lathes, Chucks, Tools, etc.



20% Down—A Whole Year to Pay

You can install a New Model South Bend Lathe in your shop under the New 1929 Easy Payment Plan by paying 20%, or one-fifth, of the total amount of the price of lathe and equipment with the order, the balance to be paid in twelve (12) equal monthly payments.

The first monthly payment is due one month from the day the lathe is shipped, and the remaining payments on the same day of each succeeding month until completed. A reminder is mailed from our office a few days before each payment is due, and remittances may be sent by check, draft or money order, as you prefer.

A Down Payment Puts the Lathe in Operation

The lathe and equipment specified on your order will be shipped to you immediately upon receipt of the order and the down payment, so the lathe can be put to work at once in your shop and the earnings used to make the monthly payments.

Any Size or Type Lathe

You can select any size or type of New Model South Bend Lathes shown in this catalog or in any of the special booklets published by the South Bend Lathe Works, paying for them under this new Easy Payment Plan. One or more lathes may be purchased, just as you prefer.

Include Tools, Accessories

You can include lathe attachments, accessories, and chucks and tools in your order to be used on your New Model South Bend Lathe, and pay for them on these same convenient terms, which give you a full year to pay. Attachments and accessories are described and priced in this catalog.

For your convenience we have enclosed an order blank and return envelope. The order blank may be used for either Easy Payment or Cash Orders.

You May Inspect Lathe Before Acceptance

If you would like to see and inspect the lathe before making the entire down payment of 20% you may send one-half of the down payment, or 10% of the total amount of order, and we will ship the lathe. We will instruct your station agent to permit you to examine the lathe upon its arrival at your city or town, and if the lathe is satisfactory pay the remaining one-half of the down payment and take possession of lathe. If it is not satisfactory ask him to return the lathe and we will refund the payment you made.

Net Factory Prices

The prices shown in this catalog are net F.O.B. cars South Bend, Indiana. In setting the prices on each lathe, tool and attachment shown, we have made the lowest possible price. Our policy is, One Quality, One Price to all whether you purchase one lathe or a number of lathes. You get the same price as large manufacturers.

Carrying Charge

The only extra cost when buying your lathe and equipment on the Easy Payment Plan is a 5% Carrying Charge on the balance remaining after you have made the 20% down payment.

This Carrying Charge takes the place of all interest and other charges and pays for the use of the money and the extra bookkeeping required in our office. It amounts to only \$5.00 on each \$100.00 of balance, or about \$4.00 on each \$100.00 worth of equipment purchased. See examples on pages 84 and 85.

Monthly Payments Include

Carrying Charge

The Carrying Charge is spread over twelve equal monthly payments as shown in examples and in the price tabulations below each lathe throughout this catalog.

EASY PAYMENT PLAN—Cont'd

□ □

Our Responsibility

The South Bend Lathe has been manufactured for more than twenty-three years. The New Models described in this catalog and offered on this Easy Payment Plan are the result of twenty-three years experience in lathe building exclusively. There are now more than 44,000 South Bend Lathes in use throughout the United States and 78 foreign countries, giving the highest type of service to their users.

We guarantee every South Bend Lathe to be accurate and mechanically perfect, to give you entire satisfaction and the service you have a right to expect—we will replace free of charge any part that proves defective either in workmanship or material within one year from the date of purchase.

This broad guarantee (printed in full on inside front cover) applies when you buy a South Bend Lathe on the Easy Payment Plan or pay for it cash in full.

A New Model Lathe

The lathe you purchase on this New Easy Payment Plan is the New Model with new features and improvements the same as we furnish to all our customers, whether paid for all in cash or month by month on the Easy Payment Plan.

One Quality Lathe

There is no sacrifice in the quality of the New Model South Bend Lathe when purchased on the Easy Payment Plan. We manufacture but one quality lathe and sell it at one price to everyone.

Ask Your Banker

Should you wish to investigate the standing of the South Bend Lathe Works ask your banker or, if you wish, write our largest banks in South Bend, the St. Joseph Loan and Trust Company and the Citizens National Bank, or refer to the Dun and Bradstreet's Mercantile Agencies.

No Finance Company

We have no connection with any commercial financing organization—we deal direct with you in the collection of your payments and it is our sincere desire to give you whatever consideration is necessary at all times. You make all your payments direct to us here in South Bend.

Time Extensions

Should illness or other similar circumstances prevent prompt settle-

ment of your payments when due, we are in a position to make allowances or permit extensions as we handle your account in our own offices and do not deal through any outside agency.

Over 6,000 Time Payment Users

More than 6,000 users of South Bend Lathes have used the Easy Payment Plan in purchasing this income producing equipment. Many of these purchasers have thus been able to greatly expand their business.

Size of Lathe for Your Work

If you have not as yet made your selection of lathe and tools, please consider that we are here to help you. If you will just indicate (no obligation whatever on your part) the size and type of lathe you prefer and tell us something about the class of work you wish to do, we will gladly advise you as to the practical type of lathe, chucks and tools best suited for your work.

Itemized Quotation

We shall be pleased to furnish you with an itemized quotation showing the exact cost of lathe, tools and accessories, listing each item separately. This will assist you in making up your order. We will also show the amount of down payment, and each monthly payment, also the freight charges on the entire equipment delivered to your station.

THE NEW 1929 EASY PAYMENT PLAN

— □ □ —

EXAMPLES

We show four examples illustrating the purchase of New Model South Bend Lathes and Equipment on the Easy Payment Plan.

No. 1—The 9-inch Junior New Model South Bend Bench Lathe, Countershaft Drive (see page 42).

No. 2—The 11-inch New Model Silent Chain Motor Driven Lathe, Quick Change Gear Type, and No. 111 Chuck and Tool Assortment (see pages 23 and 69).

No. 3—The 16-inch Quick Change Gear New Model South Bend Lathe, Countershaft Drive (see page 18).

No. 4—A reproduction of an actual Easy Payment Plan Order received.

EXAMPLE No. 1

9-inch x 3-ft. Junior New Model South Bend Bench Lathe,
Countershaft Drive

1—9-inch x 3-ft. Junior New Model South Bend Bench Lathe, Countershaft Drive (complete with Double Friction Countershaft and Equipment as illustrated and described on page 42).

Price F.O.B. South Bend.....	\$169.00
Down Payment of 20%.....	33.80
	Balance... \$135.20
Carrying Charge, 5% of Balance.....	6.76
Balance in 12 Equal Monthly Payments.....	\$141.96
Monthly Payments Each (\$141.96 divided by 12).....	\$ 11.83

EXAMPLE No. 2

11-inch x 4-ft. New Model Silent Chain Motor Driven Lathe
Quick Change Gear Type, with Chuck
and Tool Assortment

1—11-inch x 4-ft. New Model Silent Chain Motor Driven Lathe, Quick Change Gear Type (complete with Lathe Equipment; 1/2 H.P., 220 Volt, 3-Phase, 60 Cycle A.C. Reversing Motor, 1200 R.P.M.; Reversing Switch and Leather Belt as illustrated and described on page 23).

Price F.O.B. South Bend.....	\$498.00
1—No. 111 Chuck and Tool Assortment (listed on page 69).....	63.00
Price complete F.O.B. South Bend.....	\$561.00
Down Payment of 20%.....	112.20
	Balance... \$448.80
Carrying Charge, 5% of Balance.....	22.44
Balance in 12 Equal Monthly Payments.....	\$471.24
Monthly Payments Each (\$471.24 divided by 12).....	\$ 39.27

THE NEW 1929 EASY PAYMENT PLAN

EXAMPLE No. 3

16-inch x 6-ft. Quick Change Gear New Model South Bend Lathe,
Countershaft Drive

1—16-inch x 6-ft. Quick Change Gear New Model South Bend Lathe,
Countershaft Drive (complete with Double Friction Countershaft
and Equipment as illustrated and described on page 18).

Price F.O.B. South Bend.....	\$598.00
Down Payment of 20%.....	119.60
	Balance.....\$478.40
Carrying Charge, 5% of Balance.....	23.92
Balance in 12 Equal Monthly Payments.....	\$502.32
Monthly Payments Each (\$502.32 divided by 12).....	\$ 41.86

EXAMPLE No. 4

A Reproduction of an Actual Easy Payment Order for 9-inch x 3-ft.
Junior New Model South Bend Bench Lathe and No. 122
Chuck and Tool Assortment

Form 236

SOUTH BEND LATHE WORKS ORDER BLANK

SOUTH BEND LATHE WORKS
SOUTH BEND, INDIANA

Date..... *June 8th 1929.*

Please ship f. o. b. South Bend, Indiana, as soon as possible, to the undersigned at the address given below:

QUANTITY	CATALOG NUMBER	SIZE	DESCRIPTION	PRICE
1	22 Y.B.	9" x 3'	9" Junior New Model South Bend Bench Lathe	\$169. ⁰⁰
	122		Chuck and Tool Assortment for 9" Junior Lathe	62. ²⁰
TOTAL				\$231.²⁰

All complete with all standard catalog parts and equipment, which the undersigned agrees to buy for \$231.²⁰ paying \$46.²⁰ in cash herewith and the balance of \$185.⁰⁰ plus 5% in twelve equal monthly payments beginning one month after shipment is made, without interest. This order is placed subject to the terms and conditions printed on the back hereof, which the undersigned has read and agreed to.

Mailing Address *303 Pennsylvania Ave.* Name *H. E. Harrison*
City and State *Flora, Tennessee* By _____ (Owner)

NOTE—The 5% Carrying Charge is figured only on the Balance remaining after you have paid the 20% Down Payment, and not on the full amount of your order. Monthly Payments include Carrying Charge. There are no other finance fees or extra charges of any kind.

Screw Threads Cut on the New Model South Bend Lathe



Thread Gauge



Tap



Cutting a Screw Thread



Tap



Thread Gauge



Internal U. S. Standard Thread



Precision Lead Screw—Acme Thread

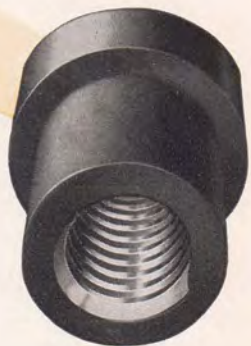

A Nut with Internal Square Thread



Right Hand Acme Double Screw Thread



U. S. Standard Thread

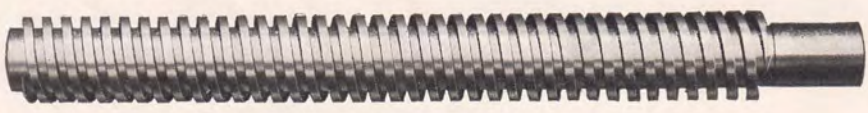

Right Hand Double Screw Square Thread

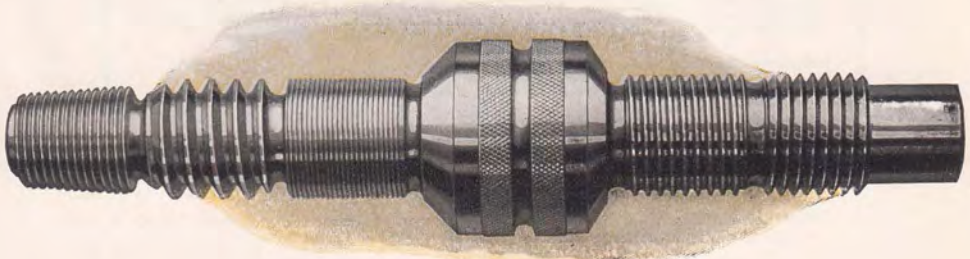

Special Screw Showing Various Types of Threads

Standard Screw Threads and Formulas

U. S. Standard Screw Thread

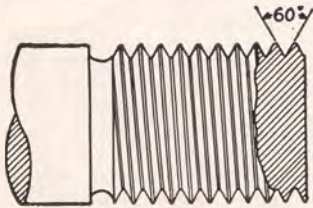

U.S. STANDARD SCREW THREADS

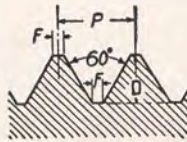

FORMULA

$$P = \text{PITCH} = \frac{1}{\text{NO. THDS. PER IN.}}$$

$$D = \text{DEPTH} = P \times .64952$$

$$F = \text{FLAT} = \frac{P}{8}$$

Acme Screw Thread

ACME SCREW THREADS

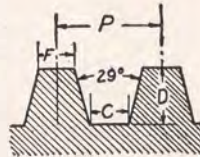
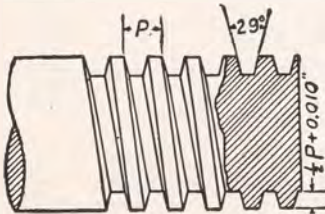

FORMULA

$$P = \text{PITCH} = \frac{1}{\text{NO. THDS. PER IN.}}$$

$$D = \text{DEPTH} = \frac{1}{2} P + .010$$

$$F = \text{FLAT} = .3707 P$$

$$C = \text{FLAT} = .3707 P - .0052$$

Square Screw Thread

SQUARE THREADS

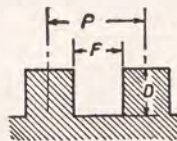
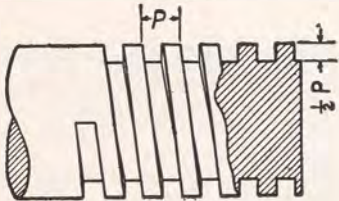

FORMULA

$$P = \text{PITCH} = \frac{1}{\text{NO. THDS. PER IN.}}$$

$$D = \text{DEPTH} = P \times .500$$

$$F = \text{SPACE} = P \times .500$$

Whitworth Screw Thread

WHITWORTH STANDARD SCREW THREADS

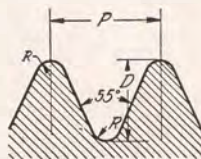
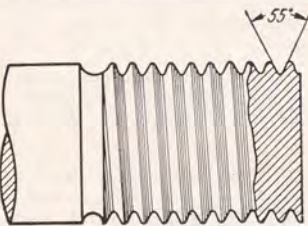

FORMULA

$$P = \text{PITCH} = \frac{1}{\text{NO. THDS. PER IN.}}$$

$$D = \text{DEPTH} = P \times .6403$$

$$R = \text{RADIUS} = .1373 P \frac{1}{\text{NO. THDS. PER IN.}}$$

Brown & Sharpe 29° Worm Thread

BROWN & SHARPE 29° WORM THREAD

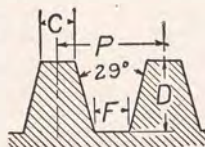
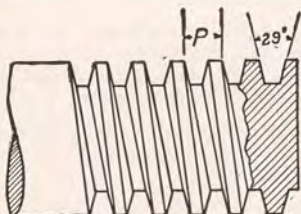

FORMULA

$$P = \text{PITCH} = \frac{1}{\text{NO. THDS. PER IN.}}$$

$$D = \text{DEPTH} = .6866 P$$

$$F = \text{FLAT} = .31 P$$

$$C = \text{FLAT} = .335 P$$

Valuable Reference Tables*

For Mechanical Work

Decimal Equivalents

Fractions of an inch	Decimals of an inch	Milli-meters	Fractions of an inch	Decimals of an inch	Milli-meters
$\frac{1}{16}$.0156	0.397	$\frac{1}{8}$.1250	3.175
$\frac{1}{8}$.0313	0.794	$\frac{3}{16}$.1875	4.762
$\frac{3}{16}$.0469	1.191	$\frac{1}{4}$.2500	6.350
$\frac{1}{4}$.0625	1.587	$\frac{5}{16}$.3125	7.937
$\frac{5}{16}$.0781	1.984	$\frac{3}{8}$.3750	9.525
$\frac{3}{8}$.0938	2.381	$\frac{7}{16}$.4375	11.112
$\frac{7}{16}$.1094	2.778	$\frac{1}{2}$.5000	12.700
$\frac{1}{2}$.1250	3.175			
$\frac{9}{16}$.1406	3.572			
$\frac{5}{8}$.1563	3.969			
$\frac{11}{16}$.1719	4.366			
$\frac{3}{4}$.1875	4.762			
$\frac{13}{16}$.2031	5.159			
$\frac{7}{8}$.2188	5.556			
$\frac{15}{16}$.2344	5.953			
$\frac{1}{8}$.2500	6.350			
$\frac{1}{4}$.2656	6.747			
$\frac{3}{8}$.2813	7.144			
$\frac{1}{2}$.2969	7.540			
$\frac{5}{8}$.3125	7.937			
$\frac{3}{4}$.3281	8.334			
$\frac{7}{8}$.3438	8.731			
$\frac{15}{16}$.3594	9.128			
$\frac{1}{8}$.3750	9.525			
$\frac{3}{8}$.3906	9.922			
$\frac{1}{2}$.4063	10.319			
$\frac{5}{8}$.4219	10.716			
$\frac{3}{4}$.4375	11.112			
$\frac{7}{8}$.4531	11.509			
$\frac{15}{16}$.4688	11.906			
$\frac{1}{4}$.4844	12.303			
$\frac{1}{2}$.5000	12.700			

Cutting Speeds of Metals

Roughing Cut

Material	Feet Per Minute
Cast Iron	60
Machine Steel	90
Tool Steel, Annealed	50
Brass	150
Aluminum	200
Bronze	90

Finishing Cut

Cast Iron	80
Machine Steel	125
Tool Steel, Annealed	75
Brass	200
Aluminum	300
Bronze	100

Cutting Screw Threads

Cast Iron	25
Machine Steel	35
Tool Steel, Annealed	20
Brass	50
Aluminum	50
Bronze	25

Rules for Calculating Pulley Sizes

Example No. 1—The revolutions of driver and driven, and the diameter of the driven being given, required the diameter of the driver.

Rule: Multiply the diameter of the driven by its number of revolutions, and divide by the number of revolutions of the driver.

Example No. 2—The diameter and revolutions of the driver being given, required the diameter of the driven to make a given number of revolutions in the same time.

Rule: Multiply the diameter of the driver by its number of revolutions, and divide the product by the given number of revolutions of the driven.

Example No. 3—The diameter and number of revolutions of the driver, with the diameter of the driven being given, required the revolutions of the driven.

Rule: Multiply the diameter of the driver by its number of revolutions, and divide by the diameter of the driven.

Example No. 4—The diameter of the driver and driven, and the number of revolutions of the driven being given, required the number of revolutions of the driver.

Rule: Multiply the diameter of the driven by its number of revolutions, and divide by the diameter of the driver.

Metric Equivalents

Length

Cm.—.3937 in.	In.—2.54 cm.
Meter—3.28 ft.	Ft.—.305 meter
Meter—1.094 yd.	Yd.—.914 meter
Kilom.—.621 mile	Mile—1.61 kilom.

Area

Sq. cm.—0.1550 sq. in.	Sq. in.—6.452 sq. cm.
Sq. m.—10.764 sq. ft.	Sq. ft.—.0929 sq. m.
Sq. m.—1.196 sq. yd.	Sq. yd.—.836 sq. m.
Hectare—2.47 acres	Acre—0.405 hectare
Sq. kilom.—.386 sq. mi.	Sq. mi.—2.59 sq. kilom.

Volume

Cu. cm.—.061 cu. in.	Cu. in.—16.4 cu. cm.
Cu. m.—35.31 cu. ft.	Cu. ft.—.028 cu. m.
Cu. m.—1.306 cu. yd.	Cu. yd.—.765 cu. m.

Capacity

Litre—.0353 cu. ft.	Cu. ft.—28.32 litres
Litre—.2642 gal. (U. S.)	Gal.—3.785 litres
Litre—61.023 cu. in.	Cu. in.—.0164 litres
Litre—2.202 lb. of fresh water at 62° F.	

Weight

Gram—15.432 grains	Grain—.0648 gram
Gram—.0353 ounce	Ounce—28.35 gram
Kilogram—2.205 lb.	Lb.—.454 kilogram
Kilogram—2.2046 lbs.	Ton (sht.)—907.03 kilo-gram
Met. ton—1.1025 ton (sht.)	Ton (sht.)—.907 met. ton
	Ton (sht.)—2,000 lb.

*Taken from book, "How to Run a Lathe." See page 94.

Sizes of Tap Drills for Standard and Special Screw Threads†

U. S. Standard Threads marked with *—S. A. E. Standard Threads marked with ‡

All Threads in Table that are not marked are Special Threads

Size of Screw	Threads per Inch	Tap Drill Size	Decimal Equivalent of Drill
1/4	20*	7	0.2010
	24	4	0.2090
	27	3	0.2130
	28‡	3	0.2130
	32	3 1/2	0.2187
5/16	18*	F	0.2570
	20	1 1/4	0.2656
	24‡	I	0.2720
	27	J	0.2770
	32	3 3/4	0.2812
3/8	16*	1 1/8	0.3125
	20	1 1/4	0.3281
	24‡	Q	0.3320
	27	R	0.3390
7/16	14*	U	0.3680
	20‡	1 3/4	0.3906
	24	X	0.3970
	27	Y	0.4040
	1/2	12	1 1/2
13*		1 1/2	0.4219
20‡		2 1/4	0.4531
24		2 1/4	0.4531
27		2 3/4	0.4687
9/16	12*	1 3/4	0.4844
	18‡	2 1/4	0.5156
	27	2 3/4	0.5312

Size of Screw	Threads per Inch	Tap Drill Size	Decimal Equivalent of Drill
5/8	11*	1 7/8	0.5312
	12	1 7/8	0.5469
	18‡	2 1/4	0.5781
	27	2 3/4	0.5937
	1 1/8	11*	1 3/4
16‡		2 1/8	0.6250
3/4	10*	1 3/4	0.6562
	12	1 3/4	0.6719
	16‡	1 1/2	0.6875
	27	2 3/4	0.7187
1 1/2	10*	2 3/4	0.7187
7/8	9*	1 3/4	0.7656
	12	1 3/4	0.7969
	14‡	1 3/4	0.8125
	18	1 3/4	0.8281
	27	2 3/4	0.8437
1 3/8	9*	2 1/4	0.8281
1	8*	1 3/8	0.8750
	12	1 3/8	0.9219
	14‡	1 3/8	0.9375
	27	2 3/4	0.9687
1 1/8	7*	1 3/4	0.9844
	12‡	1 3/4	1.0469

Sizes of Tap Drills for Machine Screw Threads

The American (National) Standard Coarse-and-Fine-Thread Series

Coarse Thread Series

Fine Thread Series

Size of Screw	Threads per Inch	Tap Drill Size	Decimal Equivalent of Drill
1	64	53	0.0595
2	56	50	0.0700
3	48	47	0.0785
4	40	43	0.0890
5	40	38	0.1015
6	32	36	0.1065
8	32	29	0.1360
10	24	25	0.1495
12	24	16	0.1770
1/4	20	7	0.2010
5/16	18	F	0.2570
3/8	16	1 1/8	0.3125
7/16	14	U	0.3680
1/2	13	1 1/2	0.4219

Size of Screw	Threads per Inch	Tap Drill Size	Decimal Equivalent of Drill
0	80	7 1/2	0.0469
1	72	53	0.0595
2	64	50	0.0700
3	56	45	0.0820
4	48	42	0.0935
5	44	37	0.1040
6	40	33	0.1130
8	36	29	0.1360
10	32	21	0.1590
12	28	14	0.1820
1/4	28	3	0.2130
5/16	24	I	0.2720
3/8	24	Q	0.3320
7/16	20	1 3/4	0.3906
1/2	20	2 3/4	0.4531

The above tabulation on pitches of standard and special screw threads with proper size tap drills for each is the latest authentic information on this subject, and has been only recently compiled in accordance with the standards of Automotive and Mechanical engineers.

†Taken from "Auto Mechanics Service Book," No. 66. See page 94.

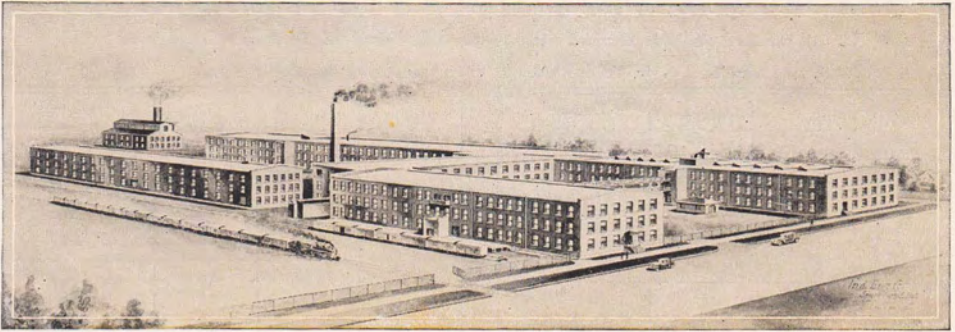

Plant of the South Bend Lathe Works, at South Bend, Indiana

History, Resources and Policy of South Bend Lathe Works

History. The South Bend Lathe Works was established in South Bend, Indiana, in 1906 and has operated continuously for twenty-three years under the same management, devoting its entire time to the building of South Bend Back Geared Screw Cutting Lathes.

The Factory of the South Bend Lathe Works illustrated above represents an investment of over \$1,000,000.00. The entire plant covers more than four acres. In the buildings there is a total of 180,000 square feet of floor space used entirely for lathe building. Our manufacturing capacity is 4,800 lathes per annum.

The New Model South Bend Back Geared Screw Cutting Lathe was developed during the last three years at a cost exceeding \$250,000.00. It is a most remarkable Lathe. Its high quality and low price has made it the most popular and widely accepted Lathe value in the United States.

Plant Facilities include the most modern machinery. More than one hundred South Bend Lathes are in operation in our shop. Special machines, fixtures, jigs and tools built in our own shop for the manufacture of South Bend Lathes insure accuracy and interchangeability. Standardization in production enables us to build in large quantities, and sell quality lathes at an exceedingly low price.

Three Hundred Skilled and Trained Workmen are employed to build South Bend Lathes. These men have had an average of ten years' experience building South Bend Lathes, and are capable of doing the highest class of workmanship that is so necessary in building the lathe.

Sixty-four Accuracy Tests are made on the major units of each New Model South Bend Lathe. These tests are made with precision instruments during the process of manufacture. The Lathe, when assembled, is operated under its own power and thoroughly tested before it is packed for shipment.

Our Reliability can be investigated. Inquire at any bank in the United States or overseas; they can inform you, from their records, of the standing of the South Bend Lathe Works. Dun, Bradstreets, American Manufacturers Foreign Credit Underwriters, Inc., and large business houses everywhere can give you reliable information about the South Bend Lathe Works.

Policy. The broad principles on which the business of the South Bend Lathe Works is conducted and upon which it has prospered for twenty-three years is to give satisfaction and service to the users of South Bend Lathes.

Visitors are always welcome at the South Bend Lathe Works. We plan interesting trips through the factory showing you the various steps in the building of South Bend Lathes, from the rough castings to the finished lathe. You will see the various models in actual operation in our demonstration room.

South Bend is located in the northern part of Indiana, 7 miles south of the Michigan State Line and 86 miles east of Chicago on the New York Central and Grand Trunk Railroads. The Lincoln Highway crosses the Dixie Highway at South Bend. Easily accessible by either railroad or automobile.

A Few Shop Views of the South Bend Lathe Works

Lathe Assembly Line

At the right—A view of the assembling line. Twenty-five lathes of one size are assembled at one time.



Assembled Lathe Units

At the left—Headstocks, tailstocks, carriages, gear boxes, compound rests, etc., carried in stock ready for assembly on the lathe.

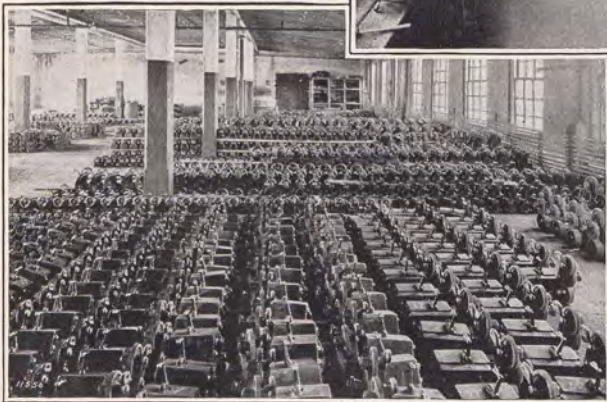

Finished Lathe Beds

At the right—The Lathe beds of various sizes are carried in stock finish planed ready for assembly.

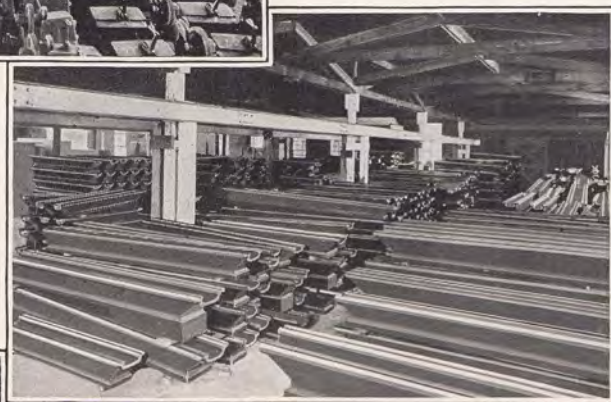

Bed Planer Room

At the left—Four Planers with twenty-four-foot tables and with four heads, are used for planing lathe beds exclusively.



A Few Shop Views of the South Bend Lathe Works



Lathes on Production Work

At the left—a group of sixteen South Bend Lathes in operation on production work.

Engineering

At the Right—Our Engineering Department which has developed the improvements on the New Model South Bend Back Geared Screw Cutting Lathe.

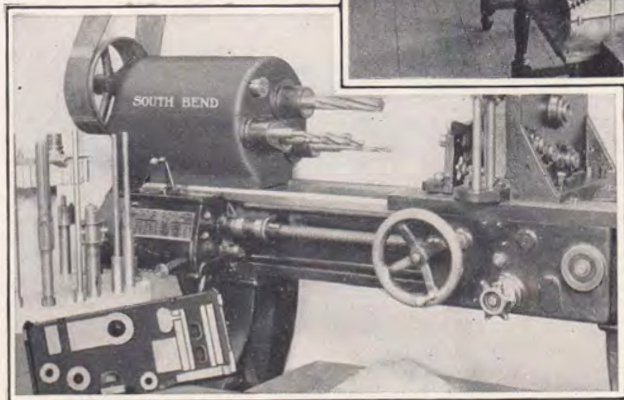

Machine for Drilling Aprons

At the left—One of the eight special drilling machines for aprons insuring interchangeability of parts.

Left
Half
of
Group



A group of employees of the South Bend Lathe Works

A Few Shop Views of the South Bend Lathe Works

Lathe Display Room

At the right—Display Room showing the various types and drives of New Model South Bend Lathes in operation to give the visitor an idea of their wide application and efficiency.

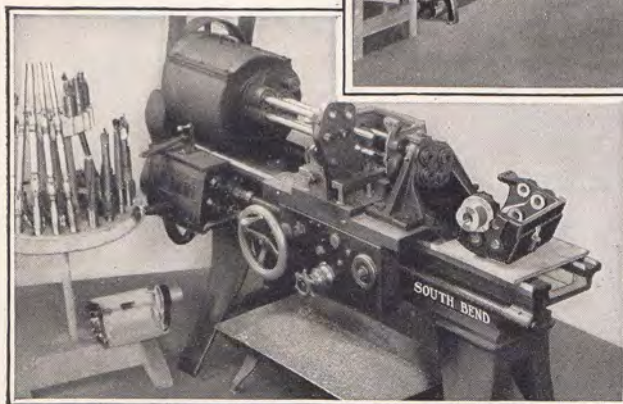
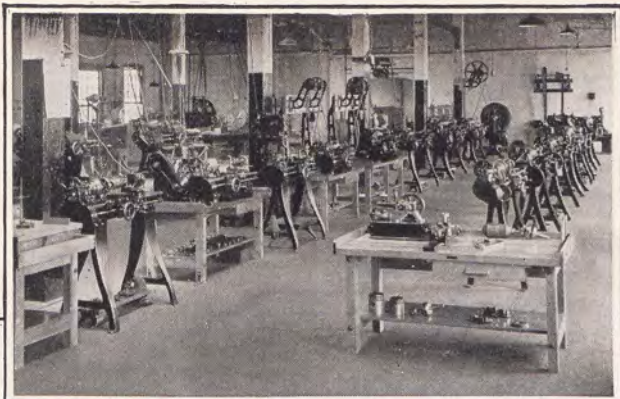

Drilling and Boring Machine

At the left—One of the eight special machines for drilling and boring gear boxes used to insure and maintain accuracy.

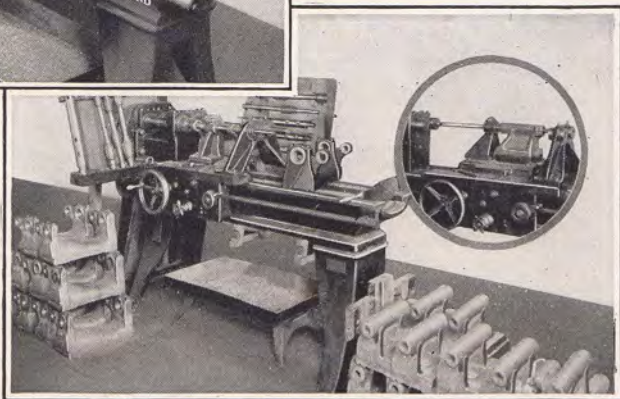

Special Boring Machine

At the right—One of the eight special machines for boring head and tailstocks, which insure accuracy and precision.



*Right
Half
of
Group*

These men have an average of ten years' experience in making lathes

Interesting Booklets for the Mechanic

Special Bulletins on Each Size Lathe

Special Bulletins of sixteen pages each, 8½x11 inches, are being printed in attractive colors for each size New Model South Bend Lathe. These Bulletins show much larger illustrations than those shown in this catalog and each illustrates and describes in detail the lathe and its various types, drives, tools and attachments.

If interested in any particular size of lathe and more detailed information is desired than is shown in this catalog, write for special bulletin specifying size of lathe.

Mailed Anywhere in the World, Postpaid, No Charge.

PARTIAL LIST OF CONTENTS

Lathes and Attachments described in the Special Bulletins

Quick Change Gear Lathes	Taper Attachment
Standard Change Gear Lathes	Grinding Attachments
Silent Chain Motor Driven Lathes	Draw-in Collet Chuck Attachment
Tool Room Precision Lathes	Milling and Keyway Cutting Attachment
Gap Bed Lathes	Turrets and Tool Slides
Brake Drum Lathes	Chucks, Tools and Accessories
Junior Bench and Floor Leg Lathes	

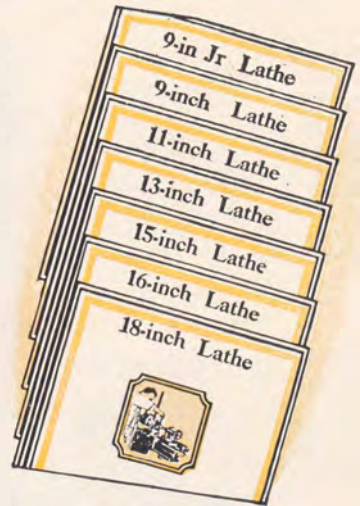

Auto Mechanics Service Book No. 66



This book is especially for the automobile mechanic. It describes and illustrates the modern methods of machining all parts of the automobile motor in the Auto Service Station, Garage, and Electrical Shop. A few jobs described are:

- Truing Commutators
- Undercutting Mica
- Refacing Valves
- Finishing Pistons
- Truing Brake Drums and Wheels
- Making Bushings
- Fitting Ring Gears
- And Many Others

It is recommended by automobile manufacturers for use in their service stations throughout the world as a reliable guide for servicing motors with precision, speed and economy. Mailed anywhere in the world, Postpaid, Price 25 Cents.

Brake Drum Bulletin No. 29



This Bulletin illustrates and describes the South Bend Brake Drum Lathes which are used as a combination lathe for brake drums, wheels and machine work in the service station or machine shop. It also describes the South Bend Mandrel and Adapter method for mounting brake drums and wheels between centers in the lathe for testing, truing and machining. This is recognized by automobile manufacturers as the most accurate and economical method for truing brake drums and mounting wheels in that they recommend it for their brake and wheel service stations in the United States and overseas. Mailed anywhere in the world, Postpaid, No Charge.

"How to Run a Lathe" No. 27

For the Apprentice in the Machine Shop

"How to Run a Lathe" is an authoritative manual covering the fundamental operations of the modern screw cutting lathe. It is a very valuable book for the mechanic as it contains complete instructions on the setting up, the care and operation of the screw cutting lathe.

This reference book is 5½x8 inches, 144 pages. There are more than one million two hundred and fifty thousand in use throughout the world. Railroad Shops and large Industrial Plants are supplying these books to their apprentices in their machine shops and more than two hundred and fifty thousand are used as text books in the shops of Vocational Schools, Trade and Engineering Schools. A copy of this book is included in the equipment of each South Bend Lathe.

Mailed anywhere in the world, Postpaid, Price 25 Cents.

PARTIAL LIST OF CONTENTS

How to Set Up a Lathe	Straight Turning and Boring
Hanging a Countershaft	Taper Turning and Boring
Calculating the Size of Pulleys	Operating the Automatic Feeds
Calculating the Speed of Pulleys	Drilling, Reaming and Tapping
Grinding Lathe Tools	Reading a Micrometer Caliper
How to Set Lathe Tools	Table of Decimal Equivalents
Cutting Standard Screw Threads	Table of Metric Measure
Cutting Acme Screw Threads	Centering and Countersinking
Cutting Square Screw Threads	General Care of Lathe

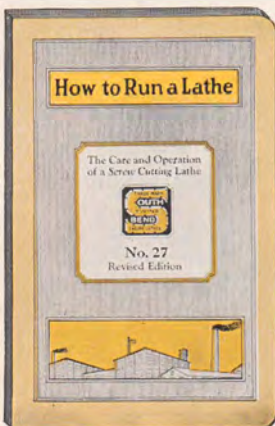

Contains 300 Shop Kinks.

Popular Sizes and Types of New Model South Bend Lathes

Net Factory Prices F.O.B. Cars, South Bend, Indiana; Crated for Domestic Shipment

Brief Specifications				Countershaft Drive Lathes				Silent Chain Motor Drive Lathes							
				Quick Change Gear Lathes		Standard Change Gear Lathes		Quick Change Gear Lathes				Standard Change Gear Lathes			
				Catalog No. of Lathe	Price	Catalog No. of Lathe	Price	Catalog No. of Lathe	3-Phase 60-Cycle A.C. Motor	1-Phase 60-Cycle A.C. Motor	Direct Current Motor	Catalog No. of Lathe	3-Phase 60-Cycle A.C. Motor	1-Phase 60-Cycle A.C. Motor	Direct Current Motor
9-inch Junior New Model South Bend Screw Cutting Lathes. See pages 42, 48															
9 1/4	2 1/2	11	1/4	Not Made in Quick Change Gear Type	22-XB	\$163.00	Not Made in Quick Change Gear Type	322-X	\$277.00	\$292.00	\$285.00				
9 1/4	3	18	1/4		22-YB	169.00		322-Y	283.00	298.00	291.00				
9 1/4	3 1/2	23	1/4		22-ZB	175.00		322-Z	289.00	304.00	297.00				
9 1/4	4	29	1/4		22-AB	182.00		322-A	296.00	311.00	304.00				
9 1/4	4 1/2	36	1/4		22-RB	190.00		322-R	304.00	319.00	312.00				
9-inch New Model South Bend Quick Change and Standard Change Gear Screw Cutting Lathes. See pages 10-11-22															
9 1/4	2 1/2	11	1/4	82-X	\$288.00	31-X	\$243.00	382-X	\$392.00	\$407.00	\$400.00	331-X	\$347.00	\$362.00	\$355.00
9 1/4	3	18	1/4	82-Y	294.00	31-Y	249.00	382-Y	398.00	413.00	406.00	331-Y	353.00	368.00	361.00
9 1/4	3 1/2	23	1/4	82-Z	300.00	31-Z	255.00	382-Z	404.00	419.00	412.00	331-Z	359.00	374.00	367.00
9 1/4	4	29	1/4	82-A	307.00	31-A	262.00	382-A	411.00	426.00	419.00	331-A	366.00	381.00	374.00
9 1/4	4 1/2	36	1/4	82-R	315.00	31-R	270.00	382-R	419.00	434.00	427.00	331-R	374.00	389.00	382.00
11-inch New Model South Bend Quick Change and Standard Change Gear Screw Cutting Lathes. See pages 12-13-23															
11 1/4	3	12	1/2	84-Y	\$345.00	33-Y	\$295.00	384-Y	\$484.00	\$512.00	\$495.00	333-Y	\$434.00	\$462.00	\$445.00
11 1/4	3 1/2	18	1/2	84-Z	352.00	33-Z	302.00	384-Z	491.00	519.00	502.00	333-Z	441.00	469.00	452.00
11 1/4	4	24	1/2	84-A	359.00	33-A	309.00	384-A	498.00	526.00	509.00	333-A	448.00	476.00	459.00
11 1/4	5	36	1/2	84-B	375.00	33-B	325.00	384-B	514.00	542.00	525.00	333-B	464.00	492.00	475.00
13-inch New Model South Bend Quick Change and Standard Change Gear Screw Cutting Lathes. See pages 14-15-24															
13 1/4	4	16	3/4	86-A	\$428.00	35-A	\$368.00	386-A	\$587.00	\$630.00	\$598.00	335-A	\$527.00	\$570.00	\$538.00
13 1/4	5	28	3/4	86-B	443.00	35-B	383.00	386-B	602.00	645.00	613.00	335-B	542.00	585.00	553.00
13 1/4	6	40	3/4	86-C	458.00	35-C	398.00	386-C	617.00	660.00	628.00	335-C	557.00	600.00	568.00
13 1/4	7	52	3/4	86-D	475.00	35-D	415.00	386-D	634.00	677.00	645.00	335-D	574.00	617.00	585.00
15-inch New Model South Bend Quick Change and Standard Change Gear Screw Cutting Lathes. See pages 16-17-25															
15 1/4	5	24 1/2	1	88-B	\$525.00	39-B	\$450.00	388-B	\$702.00	\$731.00	\$780.00	339-B	\$627.00	\$656.00	\$705.00
15 1/4	6	36 1/2	1	88-C	543.00	39-C	468.00	388-C	720.00	749.00	798.00	339-C	645.00	674.00	723.00
15 1/4	7	48 1/2	1	88-D	561.00	39-D	486.00	388-D	738.00	767.00	816.00	339-D	663.00	692.00	741.00
15 1/4	8	60 1/2	1	88-E	581.00	39-E	506.00	388-E	758.00	787.00	836.00	339-E	683.00	712.00	761.00
16-inch New Model South Bend Quick Change and Standard Change Gear Screw Cutting Lathes. See pages 18-19-26															
16 1/4	6	34	1	92-C	\$598.00	41-C	\$518.00	392-C	\$777.00	\$806.00	\$855.00	341-C	\$697.00	\$726.00	\$775.00
16 1/4	7	46	1	92-D	618.00	41-D	538.00	392-D	797.00	826.00	875.00	341-D	717.00	746.00	795.00
16 1/4	8	58	1	92-E	638.00	41-E	558.00	392-E	817.00	846.00	895.00	341-E	737.00	766.00	815.00
16 1/4	10	82	1	92-G	682.00	41-G	602.00	392-G	861.00	890.00	939.00	341-G	781.00	810.00	859.00
18-inch New Model South Bend Quick Change and Standard Change Gear Screw Cutting Lathes. See pages 20-21-27															
18 1/4	7	41 1/2	2	94-D	\$738.00	43-D	\$648.00	394-D	\$972.00	\$1024.00	\$1069.00	343-D	\$882.00	\$934.00	\$ 979.00
18 1/4	8	53 1/2	2	94-E	763.00	43-E	673.00	394-E	997.00	1049.00	1094.00	343-E	907.00	959.00	1004.00
18 1/4	10	77 1/2	2	94-G	817.00	43-G	727.00	394-G	1051.00	1103.00	1148.00	343-G	961.00	1013.00	1058.00
18 1/4	12	101 1/2	2	94-H	895.00	43-H	805.00	394-H	1129.00	1181.00	1226.00	343-H	1039.00	1091.00	1136.00
New Model South Bend Brake Drum and General Purpose Screw Cutting Lathes. See pages 72, 73															
36 1/4	6	27	1	2-BCQ	\$768.00	2-BC	\$688.00	302-BCQ	\$947.00	\$ 976.00	\$1025.00	302-BC	\$867.00	\$896.00	\$945.00
36 1/4	8	51	1	2-BEQ	810.00	2-BE	730.00	302-BEQ	989.00	1018.00	1067.00	302-BE	909.00	938.00	987.00
42 1/4	8	38	3	3-BEQ	1590.00	3-BE	1470.00	303-BEQ	1975.00	2046.00	2109.00	303-BE	1855.00	1926.00	1989.00

For Easy Payment Prices see pages on which Lathes are illustrated.

INDEX

Quick Change Gear and Standard Change Gear Lathes

	Page
9-inch Quick Change and Standard Change Gear Lathes.....	10-11
11-inch Quick Change and Standard Change Gear Lathes.....	12-13
13-inch Quick Change and Standard Change Gear Lathes.....	14-15
15-inch Quick Change and Standard Change Gear Lathes.....	16-17
16-inch Quick Change and Standard Change Gear Lathes.....	18-19
18-inch Quick Change and Standard Change Gear Lathes.....	20-21

Motor Driven Lathes

Silent Chain Motor Driven Lathes, (9-inch to 18-inch).....	22-27
Motor Driven Bench Lathes.....	37-39; 41; 44-47
Information on Motor Driven Lathes.....	28-29

Tool Room Lathes

Tool Room Lathes, Countershaft Drive.....	30-33
Tool Room Lathes, Silent Chain Motor Drive.....	30-33

Bench Lathes

9-inch Bench, Quick and Standard Change Gear Lathe.....	36
11-inch Bench, Quick and Standard Change Gear Lathe.....	40
9-inch Horizontal Motor Driven Bench Lathe.....	37
9-inch Simplex Motor Driven Bench Lathe.....	38
9-inch Self-Contained Motor Driven Bench Lathe.....	39
11-inch Self-Contained Motor Driven Bench Lathe.....	41

9-inch Junior Lathes

9-inch Junior Bench and Floor Leg Lathes, Countershaft Drive.....	42-43
9-inch Junior Horizontal Motor Driven Bench Lathe.....	44
9-inch Junior Self-Contained Motor Driven Bench Lathe.....	45
9-inch Junior Simplex Motor Driven Bench Lathe.....	46
9-inch Junior Combination Metal and Woodworking Lathe.....	47
9-inch Junior Silent Chain Motor Driven Lathe, Floor Legs.....	48

Miscellaneous Types of Lathes

Gap Bed Lathes, Quick Change and Standard Change Gear.....	50-51
Cabinet Legs Lathes (9-inch to 18-inch).....	34-35
Manufacturing Lathes (Equipped for production work).....	60
Brake Drum Lathes, Mandrels and Adapters.....	72-76

Attachments for South Bend Lathes

Draw-in Collet Chuck Attachment.....	54-57
Taper Attachment.....	58
Milling and Keyway Cutting Attachment.....	62-63
Thread Indicator, Micrometer Carriage Stop.....	59
Relieving Attachment.....	59
Raising Blocks for Lathes.....	78
Metric Transposing Gears for Lathes.....	78
Turrets for Lathes.....	61
Grinding Attachments for Lathes.....	79
Hard Maple Bench for Bench Lathes.....	70
Oil Pans, Oil Pump, Reservoir and Pipe Fittings.....	60-61

Chucks, Tools and Accessories for South Bend Lathes

Lathe Chucks, Drill Chucks and Arbors.....	64-65
Lathe Tools and Lathe Dogs.....	66-68
Chuck and Tool Assortments.....	69
Milling Cutters and Arbors.....	63
Lathe Centers, Spur Centers and Drill Pads.....	70
Easy Payment Plan on Lathes, etc.....	82-85

A Partial List of U.S.A. Industries Using South Bend Lathes

Names taken from a list of more than 44,000 users.
A printed list of recent purchasers mailed postpaid on request.

Manufacturing Plants

Nicholson File Co.
Kohler Co. of Kohler, Wis.
Federal Bearings Co.
Kirsch Mfg. Co.
Defiance Automatic Screw Co.
Link Belt Co.
Yale & Towne Mfg. Co.
Corbin Cabinet Lock Co.
Victor Adding Machine Co.
Carborundum Co.
Kelvinator Corp.
Auto Strop Safety Razor Co.
Clipper Tool Co.
Endicott-Johnson Corp.
The Hoover Sweeper Co.
Doehler Die Casting Co.
Cincinnati Ball Crank Co.
Lester Piano Co.
Sam'l J. Shimer & Sons
American Locker Co.
Reading Knob Works
Armstrong Cork Co.
Brown, Lipe & Chapin Co.
Peter Kirsch and Son
National Paper Can Co.
Gemco Mfg. Co.
Square D Company
Victor X-Ray Corp.
Columbus Conveyor Co.
Alamo Engine Co.
Adrian Wire Fence Co.
A. W. Cash Valve Mfg. Co.
Clark Equipment Co.
American Nickel Co.
American Paper Goods Co.
Peerless Weighing Machine Co.
Conn Band Instrument Co.
Parker Fountain Pen Co.
Buescher Band Instrument Co.
Chicago Apparatus Co.
Eastman Kodak Co.
National Cash Register Co.
Industrial Diamond Co.
Hercules Powder Co.
Colts Patent Fire Arms Co.
Remington Arms U.M. Co.
Ohio Match Co.
Warner Bros. Pictures, Inc.
Standard Oil Co.
Air Reduction Sales Co.
Elgin National Watch Co.
Frigidaire Corp.
Eclipse Machine Co.
Bell Telephone Laboratories
Sylvania Products Co.
Premier Adding Machine Co.
American Can Co.
Formica Insulation Co.

Accessory Parts Manufacturers

Fisher Body Corp.
Chicago Flexible Shaft Co.
Weaver Manufacturing Co.
Precision Speedometer Co.
Houde Engineering Corp.
Black & Decker Mfg. Co.
Piston Ring Co.
Monroe Auto Equipment Co.
Wel-Ever Piston Ring Co.
Bendix Brake Co.
Rich Steel Products Co.
McQuay-Norris Mfg. Co.
National Standards Co.
Cleveland Piston & Mfg. Co.
Budd Wheel Co.
Kelsey Co.
Celeron Co.
Firestone Tire & Rubber Co.

Tool Manufacturers

United Shoe Machinery Corp.
Champion Shoe Machinery Co.
Elco Tool Corporation
Gustafson-Scott Mfg. Co.
Covel-Hanchett Co.
Cleveland Planer Co.
Woodworkers' Tool Co.
Ex-Cell-O Tool Mfg. Co.
Gairing Tool Co.
Engineering Tool Corp.
Watts Bros. Tool Works
Lincoln Tool Shop
Buhr Machine Tool Co.
Michigan Tool Co.
L. O. Beard Tool Co.
McCrosky Tool Corp.
Keystone Reamer & Tool Co.
Williams Tool & Mach. Co.
Tool Engineering Co.

Tool and Die Shops

Doehler Die Casting Co., Inc.
Liberty Tool & Die Corp.
Keeley Tool & Die Co.
Detroit Die Casting Co.
Superior Tool & Die Co.
Ajax Tool & Die Works
Richard Bros. Die Co.
Gibbons Lohn Dressing & Die Company

Implement Manufacturers

Oliver Farm Equipment Co.
International Harvester Co.
Hart-Parr Co.
American Separator Co.
John Deere Co.
Iowa Dairy Cream Separator
Advance Pump Co.
Advance Rumely Co.
DeLaval Cream Separator Co.
Nichols & Shepard Co.

Steel Mills

Bethlehem Steel Corp.
Inland Steel Co.
U. S. Steel Corp.
Youngstown Sheet & Tube Co.
Federated Metal Corp.
Walter Bates Steel Corp.
Carnegie Steel Co.
Cambria Steel Co.
Latrobe Electric Steel Co.
Ft. Worth Steel Co.
Benjamin Iron & Steel Co.
Texas Steel Co.
Sheffield Steel Corp.
Lansdowne Steel & Iron Co.

Textile Mills

Amoskeag Textile Mills
Chenango Silk Co.
Southern Mills Corp.
Patchogue-Plymouth Mills
Century Ribbon Mills
Fidelity Knitting Mills
Pelham Mills
Southern Worsted Mills
Lockmere Mills

Radio Mfrs.

Radio Corp. of America
A. H. Grebe and Co.
The Sparks-Withington Co.
Fansteel Products Co.
Atwater-Kent Mfg. Co.
Howard Radio Co.

Electric Parts Mfrs.

Westinghouse Lamp Company
Nilco Lamp Works, Inc.
Fibroc Insulation Co.
Blizzard Manufacturing Co.
Graybar Electric Co.

Railroad Shops

New York Central R. R.
A. T. & S. F. R. R.
Michigan Central R. R.
Pennsylvania R. R.
Union Pacific R. R.
Louisville & Nashville R. R.
Canadian Pacific R. R.
Illinois Central R. R.
Northern Pacific R. R.
Southern Pacific R. R.
Midland Railway Co.
Great Northern Railway Co.

Aircraft Manufacturers

Pratt Whitney Aircraft Co.
Byrd Expedition.
Stearman Aircraft Co.
Stout Metal Airplane Co.
Universal Air Lines
Travel Air Mfg. Co.
Fokker Co.
Commandair Inc.

Automobile Manufacturers

Studebaker Corporation
Ford Motor Co.
Chevrolet Motor Co.
Packard Motor Car Co.
Lincoln Motor Co.
Chrysler Motor Corp.
Buick Motor Co.
Olds Motor Works
Pierce Arrow Motor Car Co.
Pontiac Motor Car Co.
Reo Motor Car Co.
Rolls-Royce of America

U. S. Government

U. S. Naval Vessels
U. S. Navy Air Service
U. S. Engineers
U. S. Signal Corps
U. S. Marine Corps
U. S. Veterans Bureau
West Point Military Academy
Smithsonian Institution
U. S. Aviation Corps
U. S. Dept. of Interior
U. S. Coast Guard
U. S. Geodetic Survey

Electric Motor Mfrs.

Western Electric Co.
Westinghouse Electric Mfg. Co.
General Electric Co.
Wagner Electric Mfg. Co.
Baldor Electric Co.
Allis-Chalmers Mfg. Co.

Steamship Companies

American Hawaiian S. S. Co.
Black Diamond Steamship Co.
Galena Navigation Co.
Kerr Steamship Co., Inc.
Munson Steamship Lines
Panama Mail Steamship Co.
Peninsular & Occidental S.S. Co.
Pittsburgh Steamship Co.
Rockport Steamship Co.
Shenango Steamship Co.
Toronto, Hamilton & Buffalo
Navigation Company
U. S. Shipping Board
Wilson Transit Company
Olympic Steamship Company

Engineering Schools

Massachusetts Institute of
Technology
Purdue University
Carnegie Institute Technology
University of Michigan
Ohio State University
Yale University
University of Illinois
McGill University, Montreal
University of Minnesota

The New Model South Bend Lathe

Is Used in all Classes of Industry
for the Machining of Metals

CLASSES OF INDUSTRIES

Using

SOUTH BEND LATHES

All Metal Working Shops	Laboratories
Automobile Mfrs.	Moving Picture Industry
Electrical Industry	Instrument Mfrs.
Radio Industry	Apparatus Mfrs.
Aircraft Industry	Hardware Mfrs.
Machinery Industry	Jewelry Mfrs.
Railroad Shops	Railroad Equipment
Mining Industry	Mfrs.
Textile Industry	Refrigerator Mfrs.
Shipbuilding Industry	Highway Departments
Agricultural Implements	Public Utilities
Bus, Cab and Truck Co's.	U. S. Government Depts.
Oil Industry	Engineering Schools
Chemical Industry	Bus and Truck Fleet
Printing Industry	Owners
Building Maintenance	Brake Service Stations
Cotton Mills	Garages
Tool and Die Works	Electrical Shops
Firearms Mfrs.	General Manufacturing

A printed booklet listing the names of prominent manufacturers in the various classes of Industry who are using the New Model South Bend Lathe will be mailed on request.

See Partial List of Users on Cover 3

