



THOR

Tool and Die Company



TURRET PUNCH PRESSES

Models 1210 and 1210AH

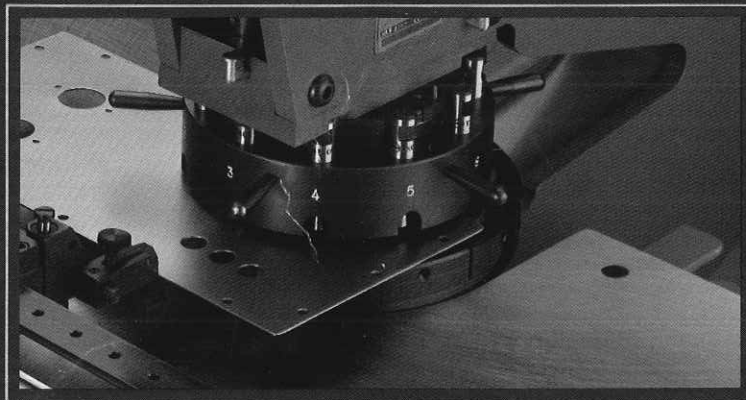

Manufacturing Precision for the Tooling Professional

Sterling
MACHINERY EXCHANGE

www.SterlingMachinery.com

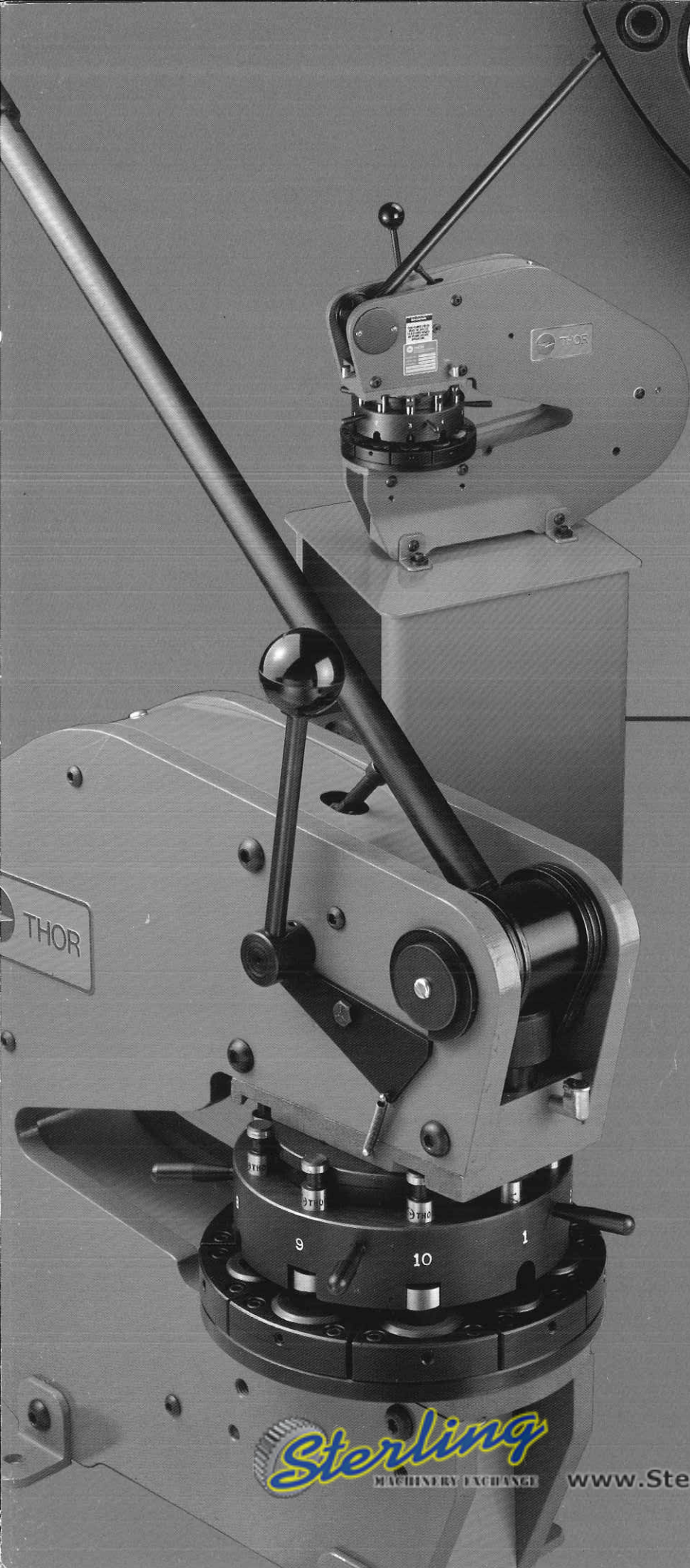

**THOR BUILDS
AFFORDABLE
PUNCH PRESSES
THAT MEET YOUR
STANDARDS FOR
EXCELLENCE.**

**Thor Model 1210 Manual
Turret Punch Press.**

*Combining Precision and
Practicality*

The hand operated Thor Turret Punch Press is unrivaled in design, workmanship, and performance. Ideal for the hole stamping requirements of prototype development, small part production, and medium production manufacturing.

Intelligently designed and engineered for precision, the Model 1210 is noted for its sturdy construction and easy tooling set-ups. Built to meet all of your punching needs quickly and accurately, the Model 1210 readily mounts on any strong work bench. Or fits perfectly with Thor accessory production worktables.

From Press Features to Press Accessories, the Thor Model 1210 is both uniquely versatile and proficient.

Sterling
MACHINERY EXCHANGE

www.SterlingMachinery.com

Turret readily accommodates fractional, decimal, or metric punch and die sizes with standard or special shapes

Die shoes are keyed for 0° and 90° tooling indexing

Individual die shoes provide fast die changes and easy alignment

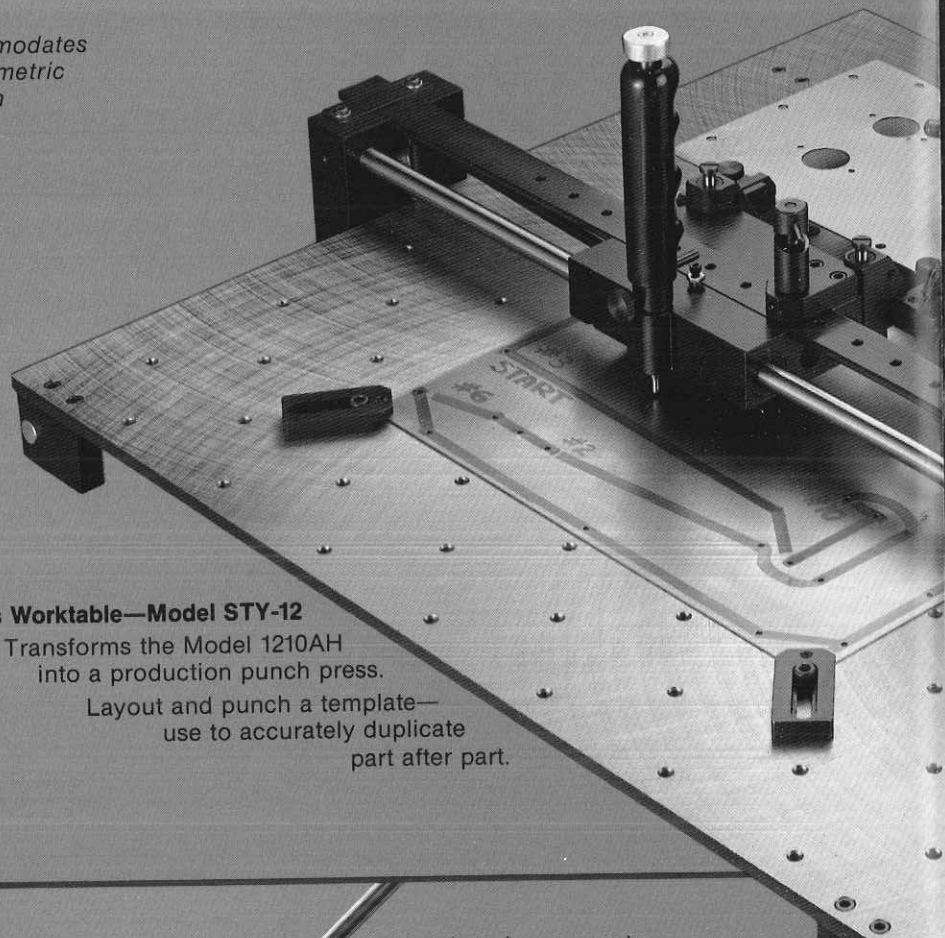

Stylus Worktable—Model STY-12

Transforms the Model 1210AH into a production punch press.

Layout and punch a template—use to accurately duplicate part after part.

Easy grip handles for convenient turret rotation

Moving parts are bearing supported

Punches 1" diameter maximum hole size through 14 gauge mild steel

10 station punch and die turret rotates in unison

12" throat accommodates 24" wide material

Hardened steel components for durability

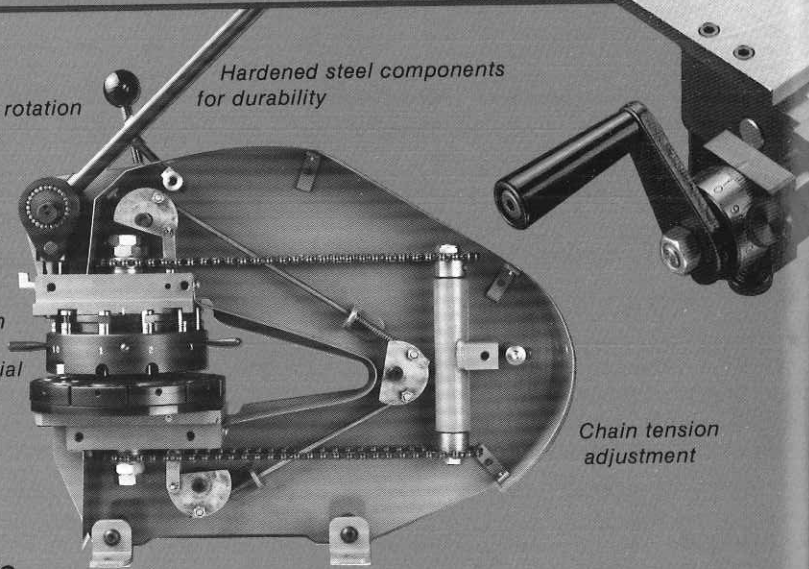

Chain tension adjustment

Thor 1210 Series Turret Punch Presses

Easy to Operate, Durable, Versatile. And Very Productive.

Intelligent Design: Ease of Operation

Thor Turret Punch Presses are designed with the press operator in mind. With 10 turret stations to choose from—instead of just one—tool changes and realignment are quick and easy. The punch and die turret rotate in unison, enabling the operator to index to other stations simply and confidently.

To operate the press, slide up to

14-gauge mild steel over the die and punch up to a 1" diameter hole in the material. The self-stripping turret automatically strips material from the punches as the ram cycles upward.

Durability: Combining Strength and Safety

Thor Punch Presses are value engineered to provide long life and reliable performance. Twin steel frame plates offer attractive styling

and extra unit strength. Thor Punch Presses are not constructed with planned obsolescence in mind. Parts subject to wear are made of hardened steel and all moving parts are bearing supported.

At Thor, safety is an integral part of our engineering concept. The Thor "ram-loc" safety device prevents any ram movement until the punch and die turret is securely locked into punching position.

Sterling
MACHINERY EXCHANGE

www.SterlingMachinery.com

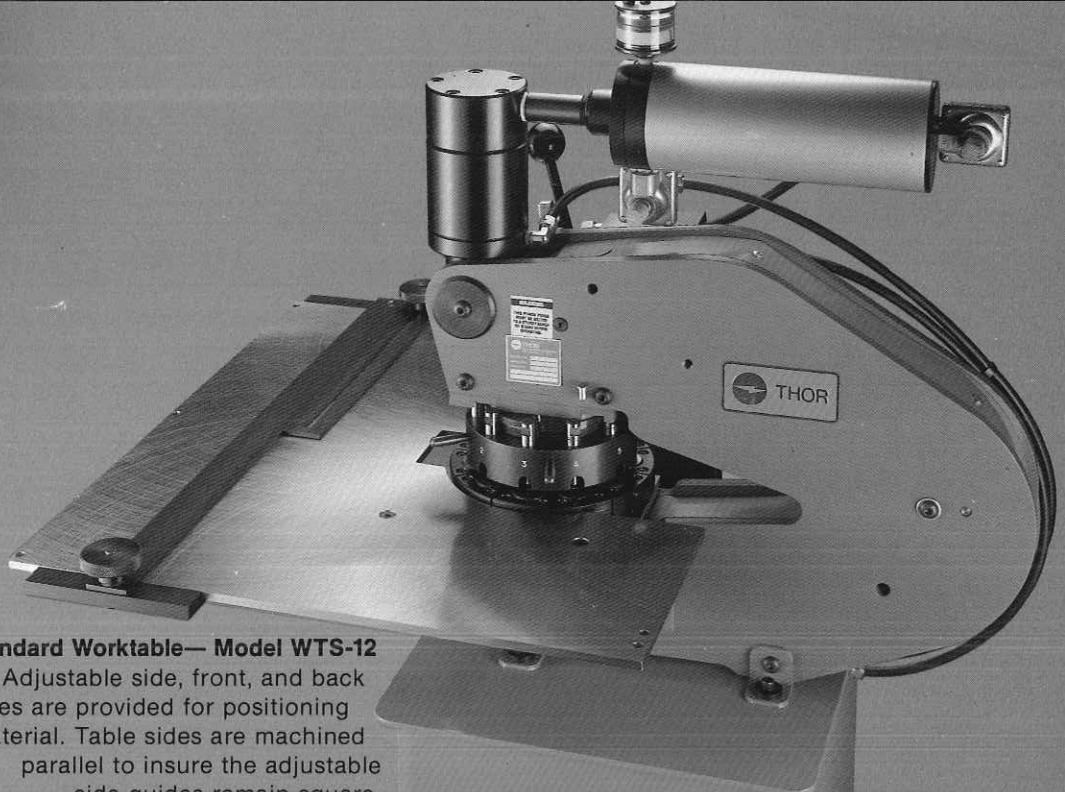
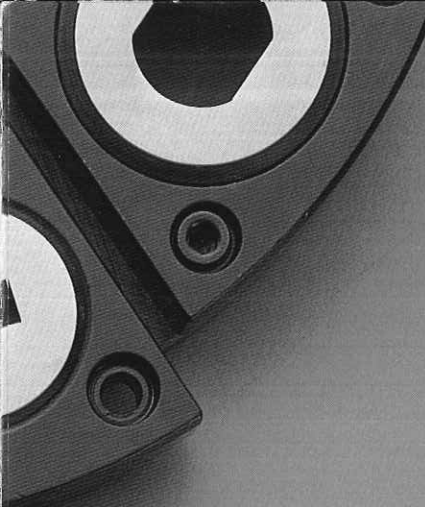

Standard Worktable— Model WTS-12
Adjustable side, front, and back gauges are provided for positioning material. Table sides are machined parallel to insure the adjustable side guides remain square.

Thor Model 1210AH Air Hydraulic Turret Punch Press.

Combining Precision and Productivity

The air powered Thor Turret Punch Press is perfectly suited for model shop applications or short to medium production runs.

Remarkable in its versatility, the Model 1210AH easily stamps *even* a single hole.

The Model 1210AH features the same design excellence and quality workmanship as the hand operated model. To increase your production levels, complement the air powered press with Thor's Standard work table, Micrometer worktable, or Stylus worktable.

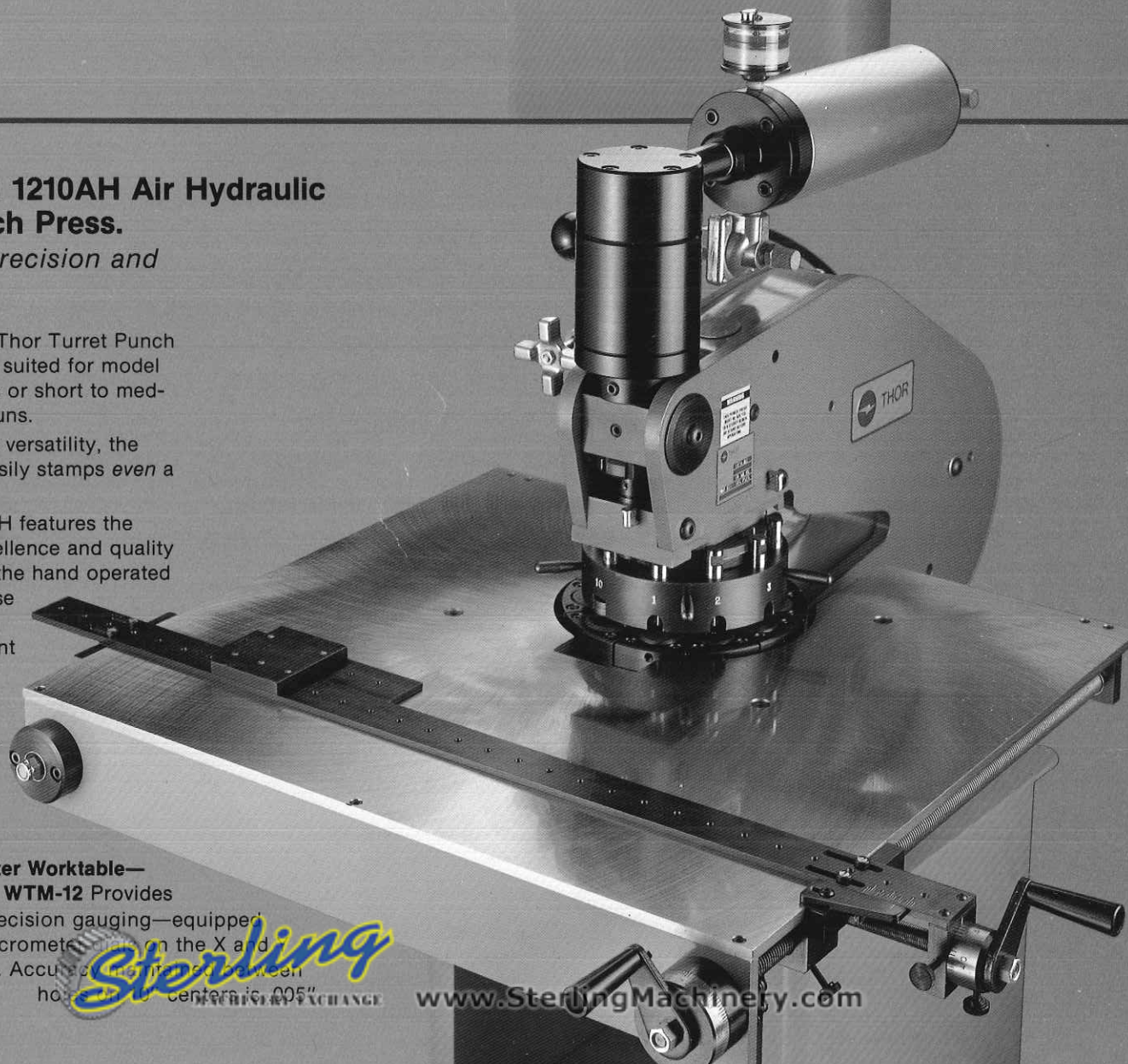

Micrometer Worktable— Model WTM-12 Provides

precision gauging—equipped with micrometers on the X and Y axis. Accuracy measured between holes in 1/16 center is .005"



www.SterlingMachinery.com

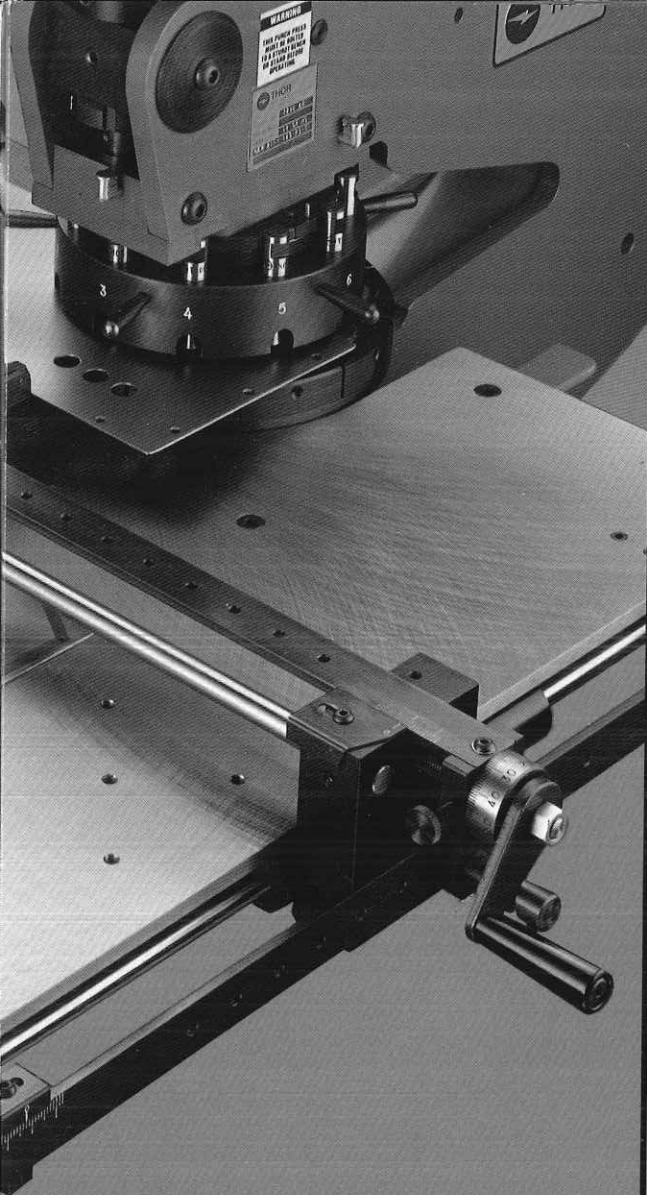

Specifications

PUNCH PRESSES	MODEL 1210	MODEL 1210AH*
Throat Depth	12" (305mm)	12" (305mm)
Stations	10	10
Maximum Material Capacity	1" (25.4mm) Diameter hole in 14 gauge (2mm) mild steel (With proper punch shear and die clearance).	
Clearance between die tops and punches	7/32" (5.5mm)	7/32" (5.5mm)
Cycles	Up to 60 strokes/minute	
Air Consumption	125 cu. in. per stroke at 100 PSI	
Press Width	3-1/2" (89mm)	3-1/2" (89mm)
Press Length	22" (559mm)	22" (559mm)
Press Height	15-1/2" (394mm)	26" (660mm)
Mounting	Bench or Stand	Floor Stand
Press Weight	125# (57kg)	138# (63kg)
Shipping Weight	152# (69kg)	165# (75kg)

* Standard features on the Model 1210AH include Thor's sturdy Model FS-12 floor stand, air filter, regulator, lubricator unit, and a foot operated air valve.

1210 SERIES TOOLING

PUNCH STYLES	STYLE #1	STYLE #2
Shank Diameter	1/2" (12.7mm)	1/2" (12.7mm)
Overall Length	2-13/32" (61mm)	2-13/32" (61mm)
Point Size Range— (Diameter or Diagonal)	Up to 1/2" (12.7mm)	Over 1/2" (12.7mm) Up to 1" (25.4mm)
Fits Station Numbers	#1 to #10	#6 to #10

For cost of tooling, see the current Thor 1210 Series Tooling Price List

DIE STYLES	STYLE A	STYLE B
Die Diameter	1-1/4" (31.7mm)	1-9/16" (39.7mm)
Die Thickness	5/8" (16mm)	19/32" (15mm)
Fits Station Number	#1 to #8	#9 and #10

ACCESSORIES

WORK TABLES	MODEL WTS-12	MODEL WTM-12	MODEL STY-12
Maximum gauge travel from punch centerline			
£ to front	9-1/2" (241mm)	8-1/2" (216mm)	—
£ to back	9-1/2" (241mm)	8-1/2" (216mm)	—
£ to left	12" (305mm)	12-1/2" (317mm)	—
£ to right	12" (305mm)	12-1/2" (317mm)	—
Maximum template size	9-1/2" x 19" (241mm x 483mm)		
Voltage	110 Volts, 60 Cycles or 220 Volts, 50 cycles (if specified)		
Table dimensions	5/16" x 22" x 24" (8mm x 559mm x 610mm)		
Net Weight	56# (26kg)	74# (34kg)	74# (34kg)
Shipping Weight	109# (50kg)	125# (57kg)	127# (58kg)

All Thor table tops are constructed of heavy duty, thick steel plates—stress relieved and precision ground to prevent warping and insure flatness. Thor worktables come equipped with necessary mounting hardware and a comprehensive instruction booklet.

FLOOR STAND	MODEL FS-12	MODEL FS-12AH For Model 1210AH Punch Press
Net Weight	84# (38kg)	84# (38kg)
Shipping Weight	102# (47kg)	114# (52kg)

Thor's sturdy floor stand provides the press operator with two shelves and a storage tray for spare tooling.

www.SterlingMachinery.com

Specifications for the 1210 Series Turret Punch Presses, accessories and tooling are subject to change without notice.

Thor Quality: Carried Through to the Smallest Detail

Every 1210 Series Punch Press is shipped complete, ready to use. Included are 1/8", 3/16", 1/4", 5/16", 3/8", 1/2", 5/8", 3/4", 7/8", and 1" diameter punches and dies installed in the turret. Punches and dies are precision machined from tool steel, hardened and ground to exact tolerances.

* Metric sizes also available



About the Company

Thor Tool and Die Company brings together a team of management and skilled personnel whose wide range of experience provides a firm base for superior quality products. Through individual dedication, Thor's people have maintained a consistently high level of quality in the Company's products and services. Thor's in-depth understanding of tooling applications and industry know-how have resulted in time proven products and a long list of satisfied clientele.

Founded in 1944 by James P. Thor, the Company's impressive reputation is built upon a solid history of quality part production, fast and reliable customer service, and technological innovation.

Beginning with the design and manufacturing of specialized hand and air tools for the heating and ventilation duct industry, Thor Tool and Die Company has successfully branched out to serve the sheet metal fabrication industry. Providing

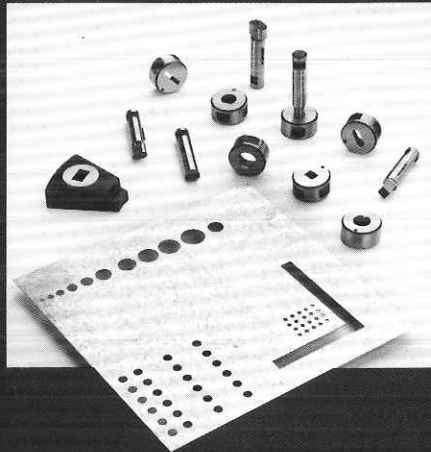

quality replacement punch press tooling that is dependable, precise, and affordable, Thor is quickly moving toward leadership in this highly competitive field.

Thor's Turret Punch Presses are indicative of the Company's continued quest for quality products, combining precision engineering with common sense practicality. Thor's ability to recognize and respond to the needs of the tooling marketplace consistently results in technological innovation. We at Thor are very proud of our Model 1210 Series Punch Presses. We're quite sure you will be, too.

Thor Tool and Die Company—
Manufacturing Precision for the
Tooling Professional

Distributed by



THOR Tool and Die Company

805 E. 14th Street • San Leandro, CA 94577-3497 USA • (415) 357-6777

Call Toll Free in California 800-772-2652 • Outside California 310-927-0799