



Waits Home Purch. 9-20-50
Serial
81-4976

PM-1526

Revised: 5-23-47

14-B: 14" Drill Press Instruction Sheets

U. S. Patent No. 2,025,834; 2,346,198; 2,360,921

14" DRILL PRESS Operating and Maintenance Instructions

Your 14-inch Drill Press has been completely assembled and tested at the factory. All that is necessary for you to do is to remove the shipping crate, loosen the nut SP-1028 that clamps the head to the column, slide the head up until the casting top is level with the top of the column and retighten the nut. The drill press is now ready for use. Do not tighten too much.

CHANGES IN HEAD CASTING

Late models of this drill press will have the following improvements of the head casting:

Two clamp sleeves SDP-21 and 22 will be used on the cap screw SP-621 to clamp the head on the column.

A new method for holding the return spring case has been adopted. Two special shoulder screws SDP-35 are threaded into the left side of the head. The clock spring case hooks under the shoulders of these screws, holding it against the head when adjusted for the correct spring tension. The lugs formerly used to hold the case have been removed.

These changes are incorporated into the parts drawing on Page 4. Be sure to include the serial number of your machine when ordering replacement parts so that changes can be taken into account in supplying your needs.

MOTORS AND SPEEDS

For light duty in the small shop, we recommend a $\frac{1}{3}$ hp, constant speed, 1725 rpm motor. A $\frac{1}{2}$ hp motor should be used under production conditions. Consult your Delta dealer for a six inch frame motor of the current characteristics to meet your requirements. Regular Delta motors are equipped with sealed ball bearings, double shafts and built-in switches.

When selecting a motor from any other source, be certain that it is capable of taking the end thrust due to the weight of the rotor, and that it is protected against loss of lubricant when operated in the vertical position. This is especially important in sleeve bearing motors.

The motor should turn in a clockwise direction when it is viewed from the top of the motor when installed. Our motors should be bolted to the bracket so that the switch is on the left-hand side as you face the drill press. If you use another motor and it runs the wrong way, either turn it around or reverse its rotation.

The four-step motor pulley is installed with the largest step at the top. Align it with the pulley on the drill-press spindle by means of a straightedge placed across both pulley edges, before tightening the setscrews. The slots in the motor bracket enable the motor to be raised or lowered to align the pulleys perfectly, which is important for smooth, vibrationless operation of the machine.

OPERATING DRILL PRESSES IN GANGS

When a number of drill presses are to be used in a gang, as for production work, they should be provided with $\frac{1}{2}$ H. P. three-phase motors, for the following reasons: Three-phase motors will save from 30 to 40 per cent of the power consumed by ordinary split-phase motors, besides delivering much more power. Since they have no brushes, commutators, delicate starting switches or starting windings, they are practically trouble-free, and this reduces upkeep cost. They are installed on a power line, and will not flicker the lights. They are particularly adapted for high-speed work.

A large gang of drill presses should never be operated with split-phase motors, taking the current from the lighting circuit. In many localities the lighting companies prohibit this, as the use of a large number of motors of this type unbalances the phase and overheats the transformer.

THREE-PHASE MOTORS

Three-phase motors cannot be operated from the lighting circuit. They are usually built for 220 volts, and this is the voltage of the ordinary power line, which is stepped down to 110 for lighting purposes. Three-phase motors should be wired by a regular electrician and provided with a regular switch, as they have no built-in switches.

Our Three-phase $\frac{1}{2}$ H. P. Motor No. 66 320 is particularly well suited to manufacturing work, as it is interchangeable with the regular No. 60 310 motor. It is a ball-bearing, double shaft motor. Note that the speed of this motor is 1725 r.p.m.

STANDARD SPEEDS

The standard speeds obtained on this machine when using a 1,725 r.p.m. motor are 680, 1,250, 2,400 and 4,600 rpm, for the high speed models; 470, 780, 1300 and 1950 rpm when the slow-speed pulley is used. The highest speed is obtained when the belt is on the largest cone on the motor pulley and the smallest cone on the spindle pulley.

TABLE ADJUSTMENTS

To adjust the table up or down, loosen the ball-end lever on the table bracket. Hold the table while doing so.

To tilt the table to the right or left loosen the pivot nut (SP-1208) under the table, remove the pin DP-8 and tilt the table to the required angle. To set the table accurately vertical, insert the pin through the hole in the table flange into the hole in the table bracket, then tighten the pivot nut. To return the table to the horizontal position, loosen the nut, withdraw the pin, set the table approximately level, then re-insert the pin through its holes and tighten the nut, when the table will be located accurately level.

SPINDLE ADJUSTMENTS

The spindle is raised and lowered by hand lever DP-233, which operates pinion shaft DP-234-S, and this, in turn, meshes with the rack on the quill DP-240. The quill can be locked at any desired point in its travel by tightening the ball-end lever DP-11. This is an especially desirable feature for router and shaper work. The adjusting screw and nut SP-703 and SD-18 are set at the factory to give the quill the proper clearance and this adjustment should not be disturbed.

DRILLING HOLES TO DEPTH

The depth pointer on the head is a very convenient feature when drilling to exact depths is to be done. To use this, run the drill down until it just touches the surface of the work. Then set the pointer to an even graduation on the quill and feed the drill into the work. The pointer will indicate when the proper depth has been reached.

Where a number of holes are to be drilled to exactly the same depth the stop nuts DP-274 on the threaded stop rod DP-273 are used instead of the pointer. After the first hole has been drilled to depth by means of the scale and pointer, the lower stop nut is set against the lug on the head through which the stop rod passes. It is then locked with the upper nut, and all subsequent holes will be drilled to exactly the same depth without reference to the scale.

ADJUSTING SPINDLE-RETURN SPRING

For the purpose of automatically returning the spindle upward after the hole has been drilled, a coil spring, DP-231, is enclosed in the case DP-232. This spring is properly adjusted at the factory, and this adjustment should not be disturbed unless absolutely necessary. If at any time it is necessary to readjust it, proceed as follows:

Loosen the locknuts SP-1227 only about $\frac{1}{4}$ inch; grip the cap tightly so as to prevent it from flying around, pull it out toward you so that the notches in the case clear the bosses on the head. Still holding the cap tightly, turn it clockwise to loosen the spring, or counter-clockwise to tighten it. Push in on the cap while turning so that the notches will slip over the bosses as soon as they are opposite. Tighten the locknuts—not too tight—and test the strength of the spring by pulling down the feed lever. Be sure the quill-lock ball-end lever is loose while testing. When the quill is up, one-half turn of the case gives the proper tension on the spring.

If the cap should accidentally be pulled out too far so that the spring end slips out of its slit in the rim of the cap, see that the hooked end of the spring is properly set in this slit again before attempting to adjust the spring.

HOW TO CHANGE SPINDLES

One of the unique features of the 14-inch Drill Press is the ease with which special spindles may be used. The operation of changing the spindle is a simple one if instructions are followed closely.

To remove the spindle that is in the machine, simply move the quill downward to expose the Allen Screw NCS-37 in collar DP-250, tighten the quill lock, loosen this setscrew and pull the spindle right out from the bottom, swinging the table out of the way before doing so.

To insert the new spindle, insert it at the bottom of the quill and push it up through the collar DP-250 and through the drive pulley. Turn the spindle while doing this so that the keys in the drive pulley will enter the keyways in the spindle. Tighten Allen Screw NCS-37 to hold the spindle temporarily. Now swing the table under the spindle again and run it up until the lower end of the chuck rests on the table. Loosen Allen setscrew again and turn the spindle, pushing up on it at the same time, until you are sure that the pin DP-248 in the spindle collar has entered the notches in the lower bearing, Fig. 3. **This is very important.** As soon as the pin has entered the notches, pull down on the lever so as to hold the chuck end of the spindle tightly against the table, then lock the quill to hold the spindle in this position. Push down collar DP-250 against its bearing, making sure that the lugs on the end of the collar enter the notches in the inner race of the bearing, then tighten the Allen setscrew again. Do not tighten the setscrew too much, or you will mar the spindle and make withdrawal difficult.

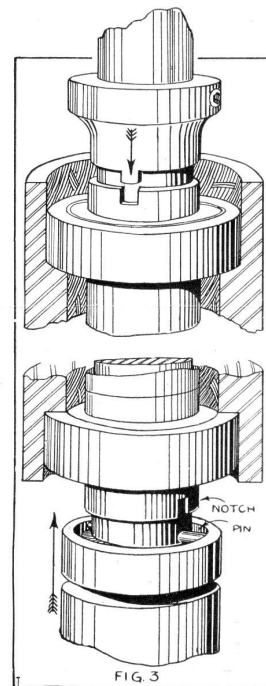

CAUTION

We have gone into this matter of changing spindles very thoroughly because it is important that it be done properly. The job is much simpler than it seems from the description, but there are two things to bear in mind. First, the pin in the collar just above the spindle chuck **must enter the notches in the lower bearing.** Similarly, the lugs on the lower end of collar DP-250 must enter the notches of the upper bearing. See Fig. 3. If this is properly attended to there will be absolutely no shake in the spindle. If there is the slightest end play in the spindle after installation then the above directions have not been followed.

ROUTING WORK

While router bits and standard machine bits may, if absolutely necessary, be used in the Jacobs chuck, we strongly recommend the use of spindle No. 974 for all work where woodworking bits with $\frac{1}{2}$ inch shanks are used. This may be used for bits with $\frac{1}{2}$ inch shanks only.

When using router bits, with the guide fence fastened on the rear of the table as shown in Fig. 5, always feed the work from left to right.

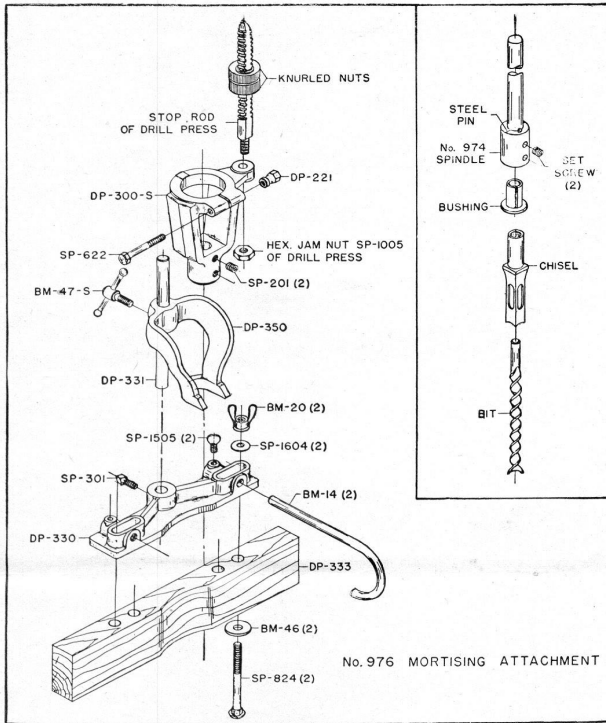

MORTISING ATTACHMENT

To attach mortising attachment No. 976, insert special spindle No. 974 in place of the regular spindle. This spindle is the only one that can be used with this attachment. Remove the stop-rod collar DP-270 from the end of the quill by loosening the nut on its clamp stud, and removing the lower nut that fastens the stop rod to the collar. Now attach the hollow chisel holder DP-300-S in place of the stop collar, slipping the rod end through the hole in the lug, replacing the lower nut and tighten the chisel holder with the clamp nut DP-221. Do not clamp too tightly.

To install the chisel and bit, insert the bit through the hole in the chisel from the cutting end, place the proper bushing over the end of the bit; then insert the whole assembly through the hollow-chisel holder. Push up until the shoulder of the chisel butts against the holder, then tighten the setscrews to hold the chisel. Push the bushing into place in the spindle chuck, and adjust the bit so that the spurs are about $\frac{1}{16}$ inch away from the lower end of the chisel. This is very important. Tighten the setscrews in the spindle chuck to hold the bushing and bit. The chuck setscrews should bear on the flat on the bushing.

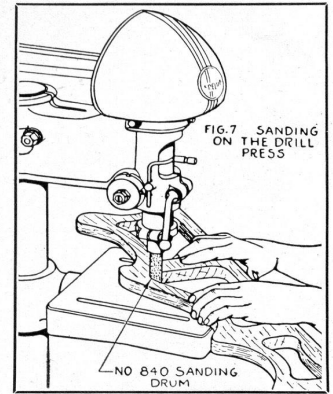
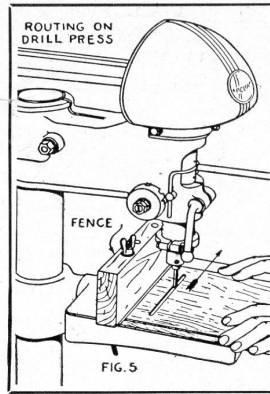

Turn the spindle by hand to see that the bit runs clear and without undue noise in the chisel. Do not make the mistake of setting the bit spurs too close to the end of the chisel, or else they will rub, and ruin both bit and chisel in a short time. On the other hand, do not let the bit extend too far, as the chips may then clog in the chisel and break the bit.

ADJUSTING GUIDE FENCE

Fasten the guide fence to the table with the bolts provided for this purpose, with the wing nuts on top of the fence. See that the hold-down arms are attached as shown in Fig. 6.

If very long pieces are to be bored or mortised, a long guide fence may be made from a piece of hard-

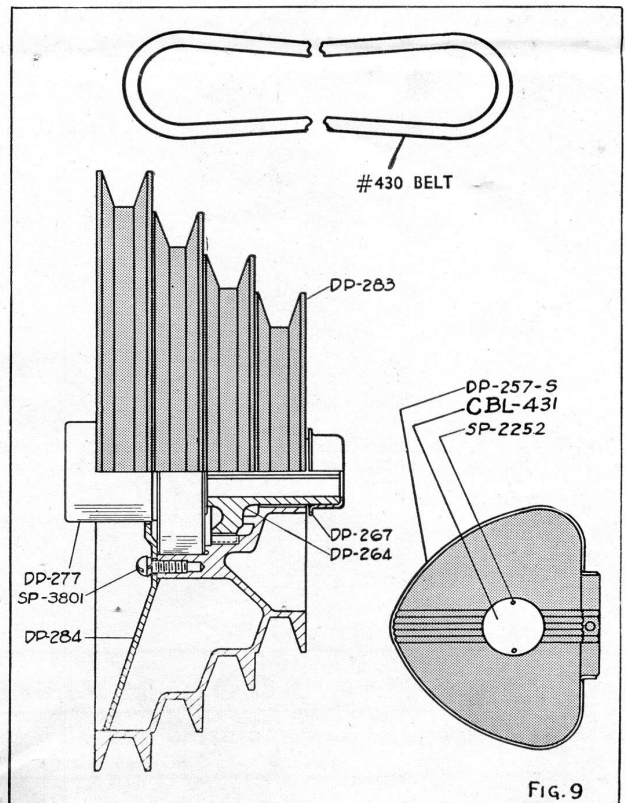

Belt # 387-28

Part no 81-4976 9/16/50

REPLACEMENT PARTS

IMPORTANT: Give both the Part Number and the Description of each item when ordering from this list; also the Serial Number of the machine on which the parts are to be used.

Part No.	Description	No. Req.	Part No.	Description	No. Req.
HEAD PARTS					
DP-6	1 x 33/64 hole, 1/8" thick steel washer	1	DP-279	3/8"-24 x 5/8" sepc. nex. hd. screw.....	1
DP-11	Ball end lever	1	SP-555	No. 8-32 x 3/8" rd. hd. mach. screws..	3
DP-220	Head casting only	1	SP-1709	Lock Washer—5/8" O.D. x 3/8" I.D. x 1/8" thick	4
DP-222	Index pointer	1	SP-3801	#8-32 x 3/8" Rd. Hd. Machine Screw ..	3
DP-222-S	Index pointer assembly	1	GUARD PARTS		
DP-223	1/4"-14 special nut	1	CBL-431	Nameplate	1
SD-18	1/4"-20 special nut	1	DP-257-S	Pulley Guard with Nameplate.....	1
SDP-21	Head Clamp Sleeve, Right, Plain End	1	SP-2252	No. 7x1/8" Drive screws.....	2
SDP-22	Head Clamp Sleeve, Left, with Socket	1	SP-3800	1/8"-18 x 7/8" fill. hd. lockwasher screw	1
SDP-35	Special #10-32 Shoulder Screw	2	STOP ROD PARTS		
SP-607	1/8"-18 x 3/4" hex. hd. cap screw.....	2	DP-221	1/4"-20 special nex. nut	1
SP-621	1/2"-13 x 3 1/2" hex. hd. cap screw.....	1	DP-270	Stop collar casting only.....	1
SP-703	1/4"-20 x 1 3/4" fillister hd. screw.....	1	DP-270-S	Stop rod assembly, with collar, etc...	1
SP-1028	1/2"-13 hex. nut.....	1	DP-273	1/2"-16 x 6 3/4" threaded stop rod only...	1
TABLE PARTS					
DP-6	1 x 33/64 hole x 1/8" thick steel washer	2	DP-274	1/2"-16 knurled stop nut	2
DP-8	Index pin	1	DP-318	Stop nut washer	1
DP-43	Table Clamp sleeve	1	SP-622	1/4"-20 x 2 hex. hd. cap screw.....	1
DP-200	Table only	1	SP-1005	3/8"-16 hex. jam nut.....	1
DP-200-S	Table assembly, with bracket, stud, pin, clamp, bolt, etc.	1	MOTOR BRACKET PARTS		
DP-204	Table bracket	1	DP-290	Motor plate	1
DP-204-R	Bracket assembly	1	DP-290-S	Motor plate assembly.....	1
DP-205-S	Ball-end clamp handle	1	DP-291	Sliding stud	2
DP-276	Spring washer	1	SBS-19	3/8"-18 hex. nut	4
SP-618	1/2"-13 x 3 1/2" hex. hd. cap screw.....	1	SP-808	1/8" x 1 carriage bolt	4
SP-667	1/2"-20 x 2 1/2" hex. hd. cap screw.....	1	SP-1030	1/8"-18 hex. nut	4
SP-1208	1/2"-20 hex. nut.....	1	SP-1604	1/8" wrough washer.....	4
SP-1607	1 1/4" x 1/2" hole x 5/64" thick steel washer	1	SP-1751	5/8" shakeproof washer	2
BASE PARTS (Floor Type)					
DP-215	Column 2 3/4" dia. 60" long.....	1	MORTISING ATTACHMENT PARTS No. 976		
DP-287	Floor base	1	DP-221	1/4"-20 Special hex. nut	1
DP-287-R	Floor base assembly	1	DP-300	Chisel holder casting only.....	1
DP-288	Cap	1	DP-300-S	Chisel holder casting complete with clamp screw nut and set screws..	1
SP-1708	1/8" dia. lock washer	2	DP-330	Hold-down casting only	1
SP-2300	1/8"-14x3 1/2" hex. hd. mach. bolt and nut	2	DP-331	Short Rod 1/2" x 6 3/8"	1
(Bench Type)					
DP-211	Base	1	DP-333	Mortising fence only.....	1
DP-213	Column 2 3/4" dia. 30" long.....	1	DP-350	Hold-down arm only.....	1
SP-207	1/8"-18 x 1/2" Allen set screw.....	2	BM-14	Curved hold-down	2
PINION PARTS WITH BALL AND SPRING					
DP-232-S	Spring case with spindle return spring	1	BM-20	Special wing nut	2
DP-233	Feed handle	1	BM-46	Washer	2
DP-234-S	Pinion shaft with ball and spring ..	1	BM-47-S	Lock bolt	1
DP-282	3/8"-24 x 1 3/8" thumb screw	1	SP-201	1/8"-18 x 1/8" Allen set screw	2
SP-1227	1/2"-20 hex. jam nut	1	SP-301	1/4"-20 x 1/2" sq. hd. set screw.....	1
PILOT WHEEL No. 969					
DP-238	Handle ball	3	SP-622	1/4"-20 x 2 hex. hd. cap screw.....	1
DP-239	Pilot wheel spoke	3	SP-824	1/8" x 4 1/4" carriage bolt.....	2
DP-631	Pilot wheel hub	1	SP-1505	1/4"-20 x 1/2" thumb screw.....	2
DP-634	Pin for pilot wheel hub	1	SP-1604	1/8" washer	2
QUILL PARTS					
DP-240	Quill only	1	SLO-SPEED DRILL PRESS PARTS No. 1290		
DP-240-S	Quill assembly with bearings.....	1	DP-264	Spindle sleeve	1
DP-242	Bearing retainer nut	2	DP-267	Spindle sleeve cover.....	1
ND-88100	Special bearing	2	DP-277	Special bearing ND-88106	1
JACOBS CHUCK AND SPINDLE No. 972					
DP-42	Jacobs Chuck with Key.....	1	DP-283	Pulley only	1
DP-250	Upper bearing drive collar	1	DP-283-S	Pulley assembly with bearing, spindle sleeve, etc.	1
DP-250-S	Collar with set screw.....	1	DP-284	Bearing retainer	1
DP-255-SA	Standard spindle with collar and drive pin, but without chuck	1	SP-1726	No. 8 lock washer.....	3
SP-201	1/8"-18 x 1/8" Allen Set Screw.....	1	#430	V-belt	1
PULLEY PARTS					
DP-264	Spindle sleeve	1	MISCELLANEOUS		
DP-265	Pulley only	1	#194	1/4" Allen wrench	1
DP-265-S	Pulley assembly complete with spindle sleeve, bearing cover	1	#387	V-belt (high speed drive)	1
DP-267	Spindle sleeve cover	1	#972	Special spindle with Jacobs chuck..	1
DP-277	Special bearing, ND-88106.....	1	#973	Special spindle for No. 1 Morse taper shank	1
DP-278	Bearing retainer	1	#974	Special spindle, 1/2" inch hole for machine bits	1
			#977	Special spindle, 1/8" inch, S.A.E. threaded end for shaper cutters	1
			#985	4-step motor pulley (1/2" inch bore)..	1
			#991	Special spindle for cup wheel	1
			#1526	Closed Ends Wrench	1
			NCS-37	Spec. 1/8" Allen Set Screw	2

CONSULT YOUR DELTA DEALER FOR PRICES OF REPLACEMENT PARTS, ACCESSORIES AND TOOLS TO FACILITATE HANDLING WE SUGGEST ORDERING ALL PARTS THROUGH YOUR DELTA DEALER

Foreign distribution is through TAUCO EXPORT CORPORATION, 38 Pearl Street, New York 4, N. Y., to Puerto Rico and the Canal Zone and to all foreign countries except Canada and the Philippine Islands.



Distribution in the United States, its possessions except Puerto Rico and the Canal Zone, and in Canada and the Philippine Islands is by authorized Delta Dealers.



POWER TOOL DIVISION

Rockwell MANUFACTURING COMPANY

MILWAUKEE 1, WISCONSIN

Printed in United States of America