

Operating the New Delta 24 Inch Scroll Saw

THE new Delta 24 inch Scroll Saw is crated and shipped in a fibre box. It should be removed from the crate carefully and mounted on a straight solid board at least 8 inches wide and 32 inches long, and *not less than 1 3/4" thick*; this is very important. Do not use plywood. Base board should be screwed or bolted to a straight and level bench. The bench should be rigid and sturdy to prevent vibration. The whole base board should be supported by the bench. Do not permit either end of the machine to project beyond the bench.

If the bench is strong, and has a straight top at least 13/4 inches (net) thick and 32 inches wide, the machine may be bolted directly to the bench top.

Unpack table, remove trunnion clamp plate, set table in position, insert clamp plate over trunnions and tighten cap screw with the socket wrench. Place a blade in the machine, setting it perfectly vertical, then set table at right angles to the blade, checking with a square if necessary. Set the pointer at the zero mark on scale, and tighten round-head screw to hold it as set.

The table can be tilted to any angle up to 45 degrees to the right or to the left, however, the lower saw blade chuck should be turned to prevent its striking the bottom of the table when the table is tilted to a greater angle than 30 degrees. If the table is tilted to the right the lower chuck should extend to the left as shown in Fig. 1. Likewise if the table is to be tilted to the left the lower chuck should extend to the right as shown in Fig. 3.

Any 1/2 or 1/4 H.P. Motor will provide ample power for this machine. Use only a constant-speed type motor; a universal motor is not satisfactory. This Scroll Saw is built to operate at a speed of 1725 R.P.M. Our pulley No. 5400 when placed on a motor having a speed of 1725 R. P. M. will drive the saw at the proper speed. This machine will run equally well whether the motor runs clockwise or counter-clockwise.

Inserting Pin Blades

To insert blades having a pin in each end, turn the pulley until the lower chuck is at the lowest point of its stroke. Loosen the hexagon screw which clamps the blade in the lower chuck, opening the jaws wide. Insert the pin blade *between the two outer movable jaws* as shown in Fig. 2. Tighten the screw and pull up on the blade slightly while tightening. Be sure the teeth of the blade point downward.

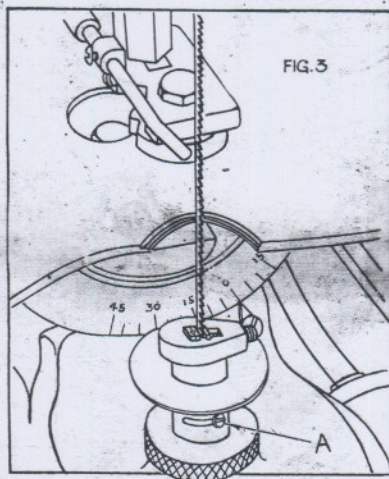

Loosen the screw on the upper chuck. Turn the pulley so that the blade is raised to its highest point. Press down on the tension spring and when 1/2 inch of the end of the blade has entered the top chuck, tighten the screw on the chuck. This completes the setting of the pin blade.

Setting the Blade Guide

The blade guide is a circular disk having slots for blades of various thickness. Loosen the capscrew shown in Fig. 8, and turn the disk so that an opening of the correct width will support

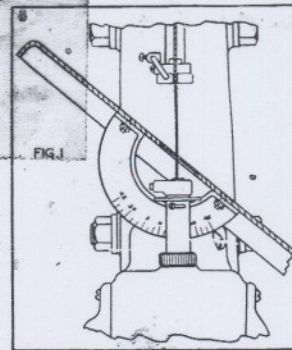

the sides of the blade. This guide should be set so that only the back portion of the blade passes through the slot. If the guide is set too far forward the teeth of the blade will strike the guide and the blade will be ruined. When the correct adjustment has been secured tighten the nut which holds the disk guide.

Adjust the guide to take the back thrust of the blade by loosening the capscrew in the end of the hexagon post. The guide should be set so that the blade does not rub hard

against it. There should be a clearance between the blade and guide of about the thickness of a calling card. When the guide has been set at the correct position tighten the capscrew securely. The guide can be set as shown in Fig. 8, when the work is to be fed from the front, and as shown in Fig. 9, when feeding the work from the left side.

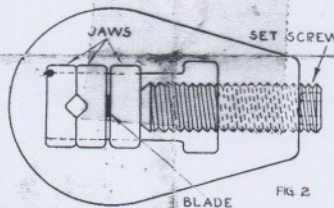

The entire guide assembly can be adjusted up or down by loosening the thumb screw which engages the hexagon post. The clearance between the blade and the guide should be the same whether the guide is at its lowest

or its highest point.

The guide should always be adjusted up or down so that the material being cut will just pass under it freely without binding.

Inserting Jewelers' Blades

To insert jewelers' blades, turn the pulley until the lower chuck is at the highest point of its cutting stroke. Loosen the screw which clamps the blade in the lower chuck. Insert the end of the blade *between the two outer movable jaws* as shown in Fig. 2. Hold the blade in a vertical position and see that the end of the blade is being held at the center of the jaws. When the blade is in the correct position tighten the nut. Loosen the screw on the upper chuck and press down the upper plunger over the blade. When the end of the blade has entered the top chuck 1/2 inch, see that it centers properly, then tighten the screw.

Set the blade guide as before.

The blade should travel up and down perfectly vertical. If the blade is clamped too far back in the top jaws, the material will be lifted from the table on the "up" stroke, which can be corrected by setting the blade perfectly straight.

Inserting Saber Blades

Saber blades, 4 1/2 inches long, can be used very successfully on this scroll saw. These blades are held in the lower chuck only. The lower chuck should be turned to the position shown

over several times by hand to see that everything is adjusted properly before turning on the power.

The paper can be changed in a few seconds as previously described without removing the attachment from the machine.

The sleeves No. 841 are made of medium grit garnet paper and are sold for \$0.45 per $\frac{1}{2}$ dozen.

The sleeves No. 842 are made of fine grit garnet paper and are sold for \$0.45 per $\frac{1}{2}$ dozen.

The scroll saw sanding attachment is our catalog No. 711 and is sold for \$1.25 complete with one sleeve.

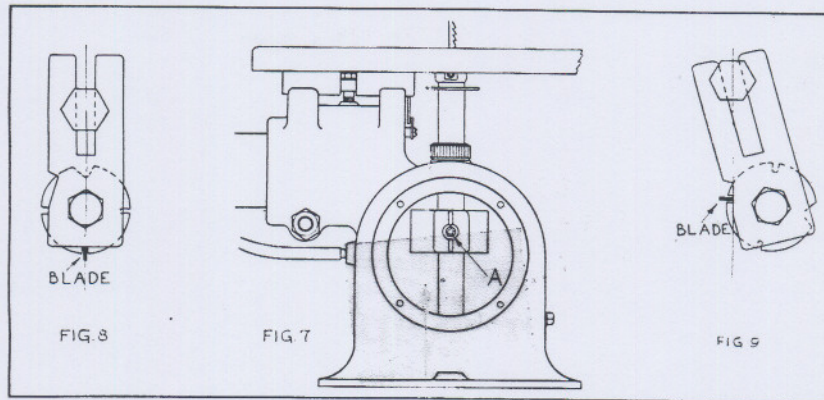

To Change the Position of the Lower Chuck

For certain kinds of work it is desirable to change the position of the lower chuck so the blades or attachments can be held in a convenient position for the work being done. Provision is made for setting the chuck in three positions. The chuck is held in position by a screw which passes through a slot in the shaft into the chuck shank. The slot will permit the chuck to be moved $\frac{1}{4}$ turn without removing the screw, but when a half turn is desired it is necessary to remove the screw and insert it into the other hole in the shank which is provided for this purpose. Figure 3 shows the position of the parts when the long part of the chuck extends to the right. The screw is shown at A. Fig. 4 shows the long part of the chuck extending to the front. Fig. 1 shows the chuck turned to the left.

To Change the Position of the Upper Chuck

To change the position of the upper chuck; remove any blade or attachment from the chucks; lower the guide to the table; pull down on the chuck until the guide pin is clear of the hole; turn the chuck until the end of the pin is opposite one of the other holes, then let the chuck up slowly. Holes are provided for setting the chuck in three positions. Both the upper and lower chucks should be turned in the same direction.

Oiling

All the lower parts which require lubrication are enclosed in the crank case. *The case must be filled before using.* All that is necessary is to remove the crank case plug occasionally and add enough oil so that it is level with the plug hole. Use only a good grade of clean, light automobile oil.

The upper slide shaft and guide pin should be lubricated with cup grease or vaseline which can be spread on when the shaft is at its lowest position.

A few drops of oil should be put in at the top of the spring about every 100 working hours.

Reversing Drive Shaft

The machine is shipped with the drive shaft on the right side as shown in Fig. 5. If desired the shaft can be reversed so that the pulley is on the left side. To reverse the position of the drive shaft; remove the four round-head screws in the drive

shaft housing and also the screws in the opposite cover; the housing and cover can then be removed. The guide on the sliding shaft must be turned half way around so that the guide fin will slide in the slot in the cover. To do this remove the nut shown at A in Fig. 7; hold the chuck with one hand to prevent the shaft from turning and turn the guide until the screw hole is opposite the other hole in the shaft. The screw can then be inserted and tightened securely.

Scrape all dirt from the flanges on the covers and the crank case, and spread a thin coating of shellac on the flanges.

Place the crank shaft and cover on before putting on the opposite cover. See that the end of the crank fits into the hole in the slide block and also see that the slide block is in the slide. The air pump should extend toward the rear of the machine. Insert the four screws in the cover and tighten each screw a little at a time until all are perfectly tight.

Turn the pulley by hand and see that all parts are in their proper places and work perfectly before putting on the other cover. The fin on the shaft guide should fit into the groove in the cover. Place this cover in position, and insert and tighten the screws. This completes the change and the pulley should be turned several times by hand to see that everything is in working order before turning on the power.

Moving the Upright Frame Nearer the Blade

The upright frame at the rear of the machine is set to give a clearance of 24 inches between the blade and the upright frame. This frame should not be moved closer to the blade at any time unless it is absolutely necessary.

It is very important that the upper sliding shaft is in perfect alignment with the lower sliding shaft so the blade will travel up and down in a perfectly vertical position.

This machine has been set in perfect alignment at the factory by using a special aligning tool.

If the upright frame is moved nearer the blade, some accurate means of aligning the sliding shafts must be employed because if the parts are out of line even a few thousandths of an inch poor results will be obtained.

Blades

Always use the widest blade possible for the work to be sawed. Use narrow blades for sawing small, abrupt curves and for fine delicate work only. This policy will not only save blades, but will produce the best work.

The Delta Scroll Saw is made to take blades 5 inches long. Pin blades, jewelers' blades, sabre blades, files or the sanding attachment may be used in this machine. There is no advantage in using the pin blades instead of the jewelers' blades, and a wider range of sizes can be obtained in the jewelers' blades.

When using extremely fine blades the speed should be reduced to 1,000 R.P.M.

To remove a blade broken off short in the lower chuck, remove the chuck and start the machine, when the blade will bounce out.

in Fig. 4, before inserting the blade. To turn the chuck, loosen the screw shown at A in Fig. 3 and turn the chuck until the screw strikes the other end of the sleeve slot, then tighten it.

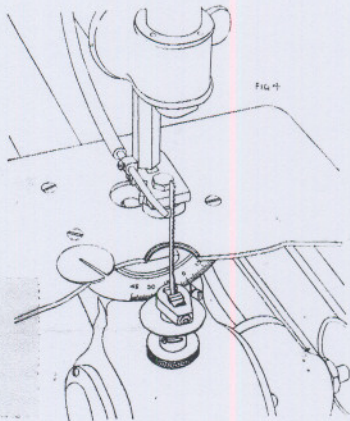

Loosen chuck screw and turn it until the rear jaws are completely open, then insert the blade in the notches in the jaws as shown, and tighten the screw. The blade must extend into the lower chuck at least $\frac{5}{8}$ inch. If it is not set deep enough in the chuck the shank of the blade will extend above the table on the "up" stroke. After setting the blade turn the pulley by hand to see that the blade does not strike the top chuck, also set the guide low enough so that the top end of the blade will be supported when the blade is at its lowest point of the stroke. If the guide is set too high the end of the blade will be forced under the guide when the work is forced against the blade, this will of course break the blade.

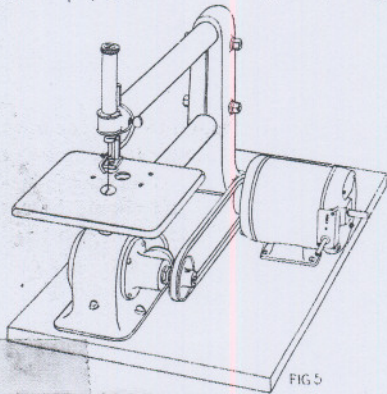

Adjust the guide as for pin blades or jewelers' blades.

Using Files in the Machine

Regular filing machine files having a $\frac{1}{4}$ inch shank will work best in this machine, although files with a tapered shank may be used for light work. The round shank gives stiffness and strength which is not obtained with files having the tapered shank.

The files may be flat, round, three cornered or square, but should not be more than 5 inches long.

To insert the file remove the table insert piece; loosen the guide-post capscrew, swing the guide to one side and tighten the screw; loosen the jaws of the lower chuck, insert the shank of the file between the notched rear jaws and tighten the chuck screw.

The Sanding Attachment for the Scroll Saw

A sanding attachment which can be used on the scroll saw is very useful for sanding the edges of irregular shaped work which has been cut on the band saw or the scroll saw. The Delta sanding attachment is semi-circular in cross section, to sand both straight and curved work.

We can furnish garnet paper sleeves of the proper size for this attachment. To change paper on the sander loosen the knurled nut at the top of the sander and slip the old paper off; slip a new sanding sleeve over the sander and tighten the nut, this will expand the parts and tighten the paper.

To use the sander, remove the circular insert piece in the saw table; loosen the blade guide and either swing it to the side or remove it entirely, in either case raise the guide post to its highest position and tighten it; insert the sanding attachment through the hole in the table so the shank fits into the notched rear jaws of the lower chuck, then tighten. Turn the pulley

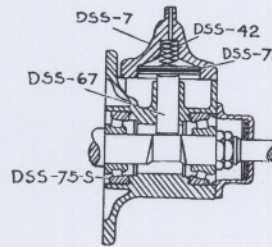
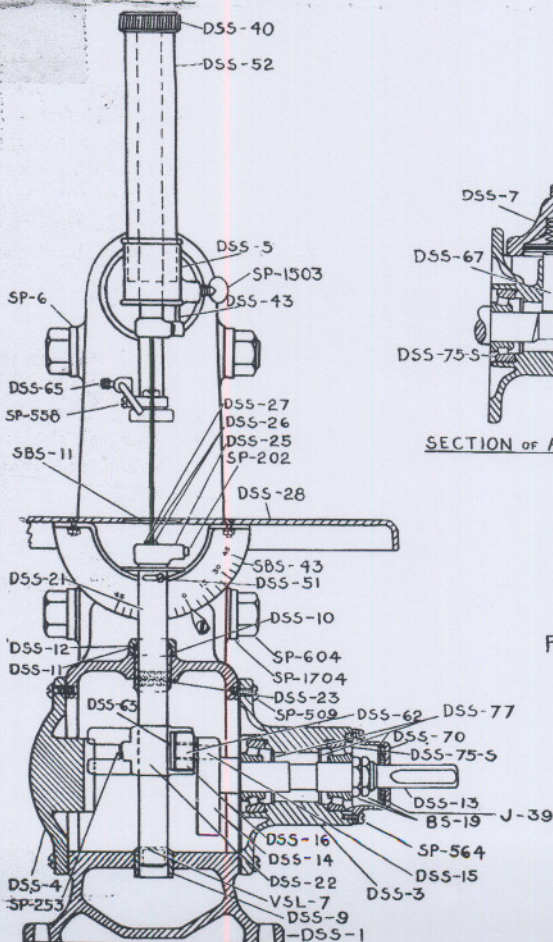

SECTION OF AIR PUMP

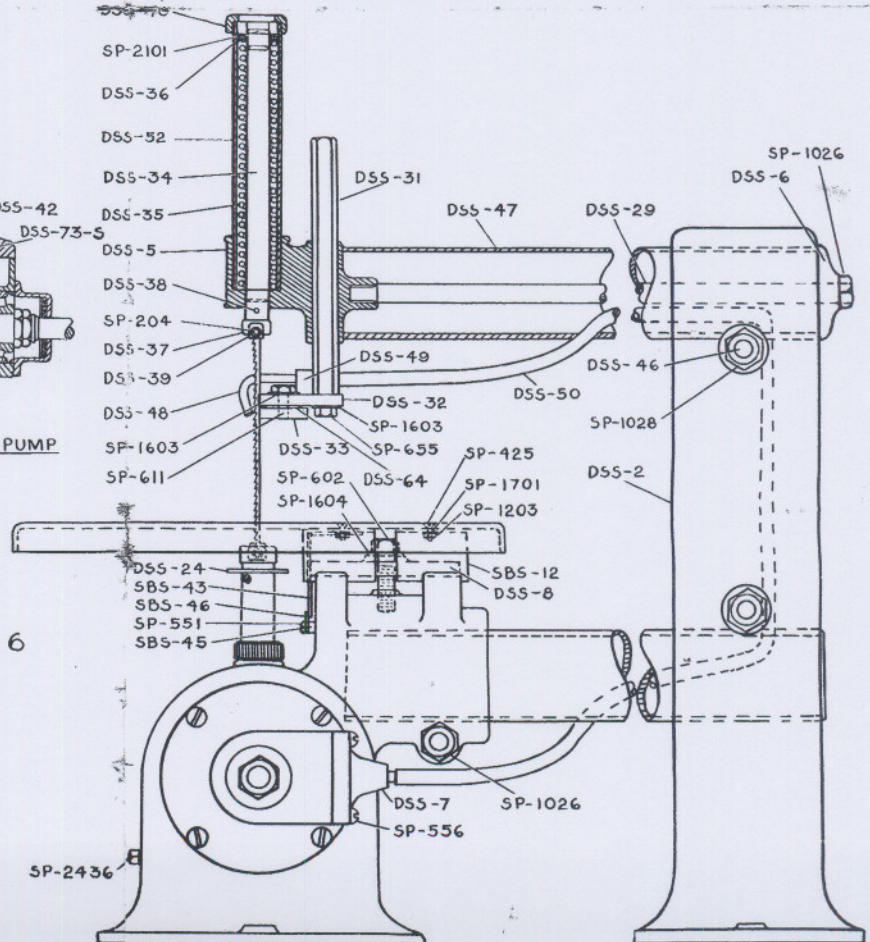

FIG 6

Removing the Lower Chuck

The lower chuck can be removed for cleaning by removing the screw shown at A in Fig. 3. The chuck can then be lifted up and removed for cleaning it of any dust or grit which may accumulate.

The Air Blower

The purpose of the blower is to keep the dust away from the top of the work in front of the blade so that the design can be seen as it is being cut and the lines followed carefully. The blower is designed so that only enough air is supplied to accomplish this result. The air is forced through a flexible rubber

tube. The rubber tubing should fit snugly over the brass tubing to prevent loss of air.

If the air fails to blow from the nozzle, examine the rubber tubing at the nozzle and the blower pump, see that the connections are tight, examine the tubing for leaks or obstructions, remove the rubber tubing from the pump and blow through the nozzle. If the tubing is free of leaks or obstruction and the air fails to blow remove the rubber tubing from the pump and place several drops of light machine oil in the blower pump. Only a few drops of oil are necessary because too much oil will find its way into the rubber tubing and destroy it in a short time. See that pump cylinder does not become jammed with fine wood dust.

How to Order Replacement Parts

If you ever should need to order replacement parts for your Delta Scroll Saw, refer to the illustration, Fig. 6, and note the number of the part you need. Find this number in the parts list, and order from us by number and name. Do not

forget to specify both name and number, as the clearer you make your instructions the better we can serve you. Also, do not forget to specify the number of parts required, if more than one is necessary.

Main Housing Parts

Part No.	Name	No. Req.	Each
DSS-1	Main Housing	1	\$4.75
DSS-4	Housing Cover	1	.50
SP-509	1/4"-20 x 1/2" R. H. Screw	8	.02
DSS-9	Lower Bushing	1	.12
DSS-10	Upper Bushing	1	.25
DSS-11	Felt Washer	1	.02
DSS-12	Knurled Gland Nut	1	.10
SP-604	3/8"-16 Hex. Hd. Screw	1	.08
SP-1026	3/8"-16 Hex. Nut	1	.04
SP-1704	3/8" Lock Washer	1	.01
SBS-45	Indicator Spacer	1	.04
SP-559	10-32 x 1/2" R. H. Screw	1	.03
SBS-46	Indicator	1	.01
SP-2436	Steel Pipe Plug	1	.08
SP-1702	1/4" Lock Washer	4	.02
SP-1603	1/4" Washer	1	.01

Drive Shaft Parts

Part No.	Name	No. Req.	Each
DSS-3	Drive-Shaft Housing	1	\$2.00
DSS-13-S	Drive Shaft, complete with crank	1	1.85
DSS-16	Fiber Slide Block	1	.40
SBS-19	Spec. 5/8"-18 Hex. Nut	2	.05
DSS-7	Blower Cover	1	.25
SP-556	10-32 x 3/4" R. H. Screw	2	.02
DSS-42	Blower Spring	1	.05
SP-1701	1/4" Lock Washers	2	.01
DSS-77	Fiber Washers	3 for	.10
DSS-70	Felt-Seal Cap	1	.20
DSS-75-S	Timken Bearing	2	1.60
DSS-73-S	Air-Pump Piston	1	.15
J-39	Felt Washer	1	.05
DSS-67	Blower Plunger	1	.15
SP-564	6-32x 3/8" Screws	3 for	.10

Lower Plunger Parts

Part No.	Name	No. Req.	Each
DSS-21	Lower Plunger	1	\$0.40
DSS-22	Crosshead	1	.45
DSS-63	Steel Crosshead Shoe	1	.15
SP-253	1/4"-28 x 1/4" Allen Cone-Pt. Screw	1	.07
VSL-7	Oil-Wick Cover	1	.05
DSS-23	Cork Plug	1	.02
DSS-24	Fiber Dust Washer	1	.04
DSS-25-S	Lower Chuck (Compl. with jaws)	1	1.00
DSS-26	Lower-Chuck V-Jaw	2	.14
DSS-27	Lower-Chuck Plain Jaw	1	.12
DSS-51	6-40 x 5/32" Spec. Screw	1	.05
SP-202	1/4"-20 x 1/8" Allen Setscrew	1	.08

No. 712	Set of 6 Individual Guides, with DSS-78 Bracket	\$1.25
No. 716	Steel Stand for Scroll Saw	7.85
No. 851	Switch Rod, with Clamp	.45

Table Parts

Part No.	Name	No. Req.	Each
DSS-28	Table	1	\$1.95
SBS-11	Center Insert	1	3 for .25
SBS-12	Table Trunnion	1	.15
DSS-8	Trunnion Clamp Plate	1	.12
SBS-43	Graduated Segment	1	.15
SP-452	10-32 x 7/8" F. H. Screw	4	.02
SP-1203	10-32 Hex. Nut	4	.02
SP-1701	3/8" Lock Washer	4	.01
SP-1604	3/8" Washer	1	.02
SP-651	1/4"-28 x 1/2" Hex. Head Screw	1	.04

Rear Column Parts

Part No.	Name	No. Req.	Each
DSS-2	Rear Column	1	\$3.10
DSS-47	Frame Tube	2	1.45
DSS-46	1/2"-13 x 4 1/2" Stud	2	.08
SP-1028	1/2"-13 Hex. Nut	4	.05
DP-6	1/2" Spec. Washer	4	.03
DSS-6	Clamp Flange	1	.10
DSS-29	Tie Rod	1	.25
SP-1026	Tie-Rod Hex. Nut	1	.04

Upper Plunger and Saw-Guide Parts

Part No.	Name	No. Req.	Each
DSS-5	Upper Head (casting only)	1	\$0.75
DSS-31	Hex. Saw-Guide Post	1	.15
DSS-32	Blade-Guide Plate	1	.25
SP-612	1/4"-20 x 5/8" Hex. Hd. Screw	1	.02
SP-1603	1/4" Washer	1	.02
DSS-33	Hardened Blade-Guide Disc	1	.25
SP-611	1/4"-20 x 1/2" Hex. Hd. Screw	1	.02
DSS-34	Upper Plunger	1	.35
DSS-35	Upper Plunger Spring	1	.25
DSS-36	Fiber Washer	4	.02
SP-2101	3/32" x 5/8" Cotter Pin	1	.01
DSS-37-S	Upper Saw Blade Chuck (with jaws)	1	1.00
DSS-39	Upper Chuck Plain Jaw	2	.12
DSS-38	Upper Chuck Pin	1	.08
DSS-40	Knurled Safety Cap	1	.12
SP-204	1/4"-20 x 3/8" Allen Setscrew	1	.07
DSS-43	Upper Plunger Guide Pin	1	.05
DSS-48	Blower Nozzle	1	.15
DSS-49	Blower-Nozzle Bracket	1	.10
DSS-65	Nozzle Adjusting Screw	1	.08
DSS-52	Upper Plunger Casing	1	.35
DSS-50	Rubber Tubing	5 ft. req.	per ft. .10
DSS-41-S	Socket Wrench	1	.35
SBS-47	Wrench	1	.10
DSS-44-S	Chuck Wrench	1	.20

Delta Manufacturing Company

3775 N. Holton Street

Milwaukee, Wisconsin