

Boice Crane

FRANKLIN 1
1150 H ST.

SACRAMENTO 14
2031 JAY ST.

HAVEN
SAW & TOOL CO.

SAN FRANCISCO 3
1072 HOWARD ST.

OAKLAND 6
950 E. 14th ST.

POWER TOOLS

for

CUTTING • SHAPING
DRILLING • FINISHING

WOOD METAL FIBRE PLASTICS

in

INDUSTRY • SCHOOLS • HOME SHOPS

FLEXIBLE

Readily adaptable to a wide range of projects, fewer Boice-Crane machines are needed to meet your requirements.

SAFETY ENGINEERED

Boice-Crane tools may be operated by inexperienced hands, since every precaution has been taken to make them as nearly 100% safe as modern devices permit.

BUILT TO OUTLAST

Boice-Crane tools can take a beating which would incapacitate most machines.

INDEX

	Page		Page
Band Saws	23	Planers	42
Drill Presses	16	Sanders	
Grinders, Tool & Knife	22	Belt	32
Jig Saws	27	Drum	40
Jointers	8	Spindle	30
Lathes	34	Saw-Jointers	10
Misc. Accessories & Supplies	38, 39, 40	Saw Tables	11
Motors	41	Shapers	2
		Cutters	5



THICKNESS PLANERS

DRILL PRESSES

LATHES

SPINDLE SANDERS

JIG SAWS

BAND SAWS

BELT SANDERS

SPINDLE SANDERS

JOINTERS

SAW JOINTERS

BOICE-CRANE

No. 2100 FLOOR TYPE SPINDLE SHAPER

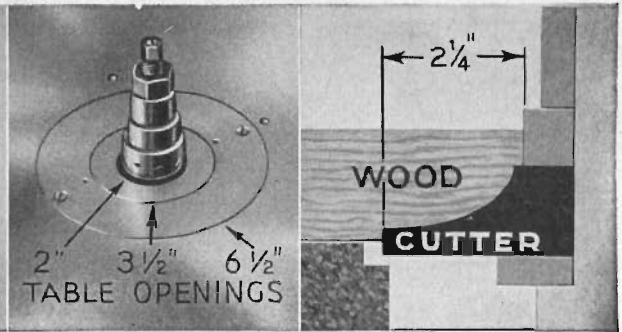

... AND HANDLES KNIVES TO 2 1/2" WIDE

In addition to handling solid-wing-cutters to 3 inches wide and from 1 3/4 to 6 1/4 inches diameter on either one or the other of the two Boice-Crane cutter-arbors . . . the Boice-Crane 3/4 inch cutter-arbor is regularly equipped with a pair of conventional notched knife-collars. Thus you are fully equipped to shape with knives to 2 1/2 inches wide—at no additional cost.

Precision Built SPINDLE . . . and Sealed for Life BALL BEARINGS

The Boice-Crane spindle, 1" dia. at bearings, is ground to precision dimensions and is carried on two very high quality ball bearings of dust sealed, and grease-sealed type. No dust can enter bearings. No grease can leak out. The bearing-seats in the quill-casting, as well as the entire body of quill are all finely ground to precision dimensions. Our spindle stays true even after years of running wide, deep cuts with cutters of a size that would "stop" most shapers.

No Ordinary Big Cutter "Stops" the Boice-Crane

A Boice-Crane has what it takes to run sash mouldings, wide Chippendale mirror mouldings, deep and wide thumb-moulds, raised-panels and the like . . . in just one single cut. And on cutters like our Nos. 401 to 443, a Boice-Crane completes the job while most others have barely begun. These are the reasons why sash-and-door, cabinet, school, and furniture shops, and also those many home-shop men who enjoy only the best, have all taken so to Boice-Crane Shapers. It's the best choice for your shop too!

2 SPINDLE SPEEDS — CHOICE OF MOTORS MEET VARIED NEEDS

7200 R.P.M. SHAPER

Note: Recommended for all general purpose work. 7200 r.p.m. on the Boice-Crane with 3" diameter cutters equals the performance of other make 10,000 r.p.m. shapers usually capable of handling cutters only up to 2" diameter. This model handles cutters up to 6 1/4" diameter, whereas on our 10,000 r.p.m. shaper we do not recommend cutters larger than 4" diameter at that speed. Order this shaper for use with our No. 2112A Sash Cutters and No. 2114 Cabinet Cutters.

No. 2125 Complete unit, including shaper as specified below, fence, guard and hold-down, belt guard, 2 V-belts, motor pulley. Shipping weight—Domestic 250 lbs. Export 400 lbs. 24 Cu. Ft.

Above unit consists of the following:

- No. 2100** Floor type Shaper including outer table ring, 2 notched collars 1 3/4" dia., 3 fill-in collars, starting pin, 6" dia., motor pulley, two No. 1035 V-belts and motor bracket. No motor or cutters. Ship. wt. 200 lbs.
- No. 2130** Fully adjustable Fence. (Illustration page 4.) Ship. wt. 25 lbs.
- No. 2131** Guard and Hold-Down. (Illustration page 4.) Ship. wt. 7 lbs.
- No. 2106** Guard over motor-pulley and belts. (Illustration page 4.) Ship. wt. 12 lbs.

OPTIONAL MOTORS FOR 7200 R.P.M. SHAPERS

No.	H.P.	RPM's	Type	Volts	Cycle	Phase	Wt.	Price
* 485	1/2	1750	R.I.	110/220	60	1-ph.	66 #	
*2110	1/2	1750	R.I.	110/220	60	1-ph.	62 #	
†2109	3/4	1750	Cap.	110/220	60	1-ph.	69 #	
†2124	1	1750	3-ph.	220/440	60	3-ph.	90 #	
†2140	1 1/2	1750	Cap.	110/220	60	1-ph.	100 #	
†2141	1 1/2	1750	3-ph.	220/440	60	3-ph.	90 #	

* NOT REVERSIBLE. Capacity limited to narrow, shallow cuts—cutter sizes up to 1" wide x 2"—2 1/2" diameter. Won't pull cutter sets #2112A and #2114. Ball Bearing.

† REVERSIBLE. Includes reversing drum switch. When ordering specify single connected voltage. Ball Bearing.

Specify motors Nos. 485 and 2110 for light duty.
 " " " 2109 and 2124 for average duty.
 " " " 2140 and 2141 for heavy duty.

10,000 R.P.M. SHAPER

Note: High production woodworking plants principally in the furniture field prefer Boice-Crane 10,000 r.p.m. shapers. The higher speed gives 33% to 50% faster production, and up to 50% smoother cuts. At 10,000 r.p.m.'s Boice-Crane 3 3/4" Tru-Form two-wing cutters reach a cutting point peripheral speed of over 100,000 inches per minute—producing finest quality cabinet work. Recommended for cutters up to 4" diameter.

No. 2165 Complete unit, includes shaper as specified below, fence, guard and hold-down, belt guard, 2 V-belts, motor pulley. Shipping weight—Domestic 250 lbs. Export 400 lbs. 24 Cu. Ft.

Above unit consists of the following:

- No. 2150** Hi-Speed, 10,000 r.p.m. Shaper, floor type, including outer table ring, 2 notched collars 1 3/4" dia., 3 fill-in collars, starting pin, 6" dia., motor pulley, two No. 1036 V-belts and motor bracket. No motor or cutters. Ship. wt. 200 lbs.
- No. 2130** Fully adjustable Fence. (Illustration page 4.) Ship. wt. 25 lbs.
- No. 2131** Guard and Hold-Down. (Illustration page 4.) Ship. wt. 7 lbs.
- No. 2106** Guard over motor-pulley and belts. (Illustration page 4.) Ship. wt. 12 lbs.

OPTIONAL MOTORS FOR 10,000 R.P.M. SHAPERS

No.	H.P.	RPM's	Type	Volts	Cycle	Phase	Wt.	Price
†2151	1	3450	Cap.	110/220	60	1-ph.	85 #	
†2155	1	3450	3-ph.	220/440	60	3-ph.	55 #	
†2156	1 1/2	3450	Cap.	110/220	60	1-ph.	90 #	
†2157	1 1/2	3450	3-ph.	220/440	60	3-ph.	80 #	

† REVERSIBLE. Includes reversing drum switch. When ordering specify single connected voltage.

All above motors are ball bearing.

Specify motors Nos. 2151 and 2155 for average duty.
 " " " 2156 and 2157 for heavy duty.

IMPORTANT NOTE: Reversible wing type cutters with reversible motor, speed production. Peak production on parts requiring cuts in both directions produced by using two Boice-Crane Shapers each running in opposite directions using opposite-hand one-way cutters.

SHAPER SUPPLIES AND ACCESSORIES

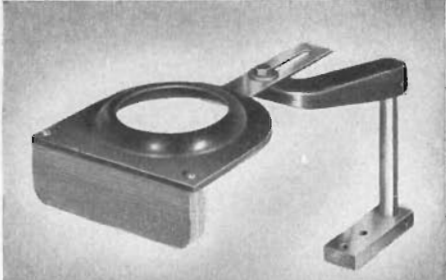

No. 2131 Guard and Hold-Down for all Boice-Crane Shapers Nos. 2100, 460, and 560. Complete, ready to attach. Ship. wt. 7 lbs.

Here is really a guard that makes shaper operation safe for anyone. Same type used in mills for years. Quickly adjusts to thickness of work. Pressure on work under operator's control. Does not obstruct view of work. Wood face prevents scoring the material.

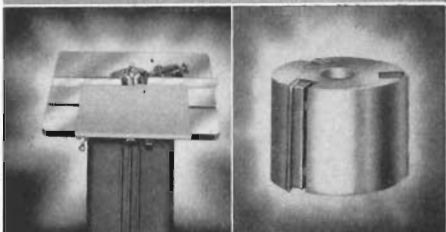

No. 2103 Jointer Head with 3 sharpened high speed steel knives and wrench. Ship. wt. 3 3/4 lbs.

Make your Boice-Crane Shaper an efficient Jointer with this low price Jointer Head. Better than a jointer for wide materials. Edges and shapes in one operation saving band sawing and sanding. Highest grade steel for safe high speed use. Three 2" wide knives securely held by taper wedges. Fits previous Boice-Crane Shapers and No. 2100, or any make with 3/4" dia. spindle.

No. 2104 3 required 2-inch wide sharpened knives. Ship. wt. 3 oz. Per set of 3

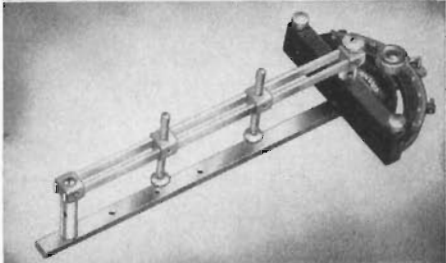

No. 2502 "Auto-Set" Miter Gauge complete with end-stop rods and wrench. Ship. wt. 4 1/2 lbs.

Our famous "Auto-Set" Miter Gauge becomes a very handy device for shaping across end-grain on short, narrow pieces. An extra protection for the operator too, and saves spoiled work at the end of the cut when bearing on the fence is reduced.

No. 2503 Clamp Attachment for No. 2502 Miter Gauge Pat. No. 1,894,010. Ship. wt. 1 1/2 lbs.

No. 2503 Clamp Attachment still further assists feeding on end-grain shaping. Leaves nothing for the operator to do, but feed the work.

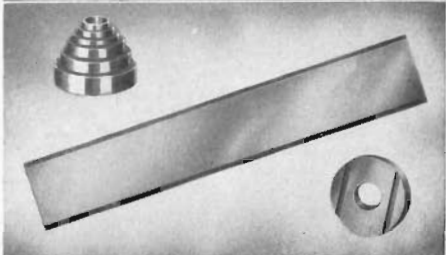

Notched Shaper Collars
3/4" Hole Per Pair
No. 2118 1 3/4" dia.
No. 2119 2 3/4" dia.
Ship. wt. 1 1/2 lbs.

Boice-Crane Shaper Collars are truly precision made. Every one carefully trued, ground, then balanced into pairs. Grooves carefully machined too so knives are clamped with equal pressure.

No. 2107 Collar Set. Not illustrated. Ship. wt. 8 oz.

Collar Set No. 2107 consists of four ground steel rubbing collars 1" to 1 3/4" O.D. increasing by quarters, plus 3/8" and 3/4". For either 1/2" or 3/4" arbors.

Bevel Edged Knife Stock
No. 2115 1" x 3/8" x 12" long
No. 2116 1 1/2" x 3/8" x 12" long
No. 2117 2" x 3/8" x 12" long
Ship. wt. 1 1/2 lbs.

Our Knife Bar Stock is fine high-speed steel from which you can make special pattern knives at low cost. Accurately bevelled and uniform thickness for finely balanced, easy to grip knives.



No. 2130 Fully adjustable Fence for Boice-Crane No. 2100 Shaper. Ready to attach. Ship. wt. 25 lbs.

Bigger, more durable, more practical. Runs more jobs with bigger range of cutter diameters. Full 27 inches of guiding surface. Each face 2 1/4" high. Screw, micrometer adjustment on each face, also on complete guide. Adjusts for any cutter 1" to 6 1/2" diameter. Hold-downs available at slight extra cost.

No. 2133 Pair of Hold-downs. Ship. Wt. 3 lbs.

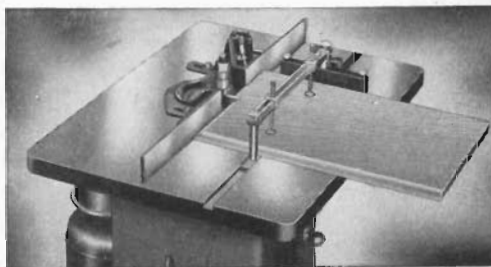

Extra large table with spindle scientifically placed close to its center—a very important feature. Provides plenty of table behind spindle to give firm support to work of big sweep, as well as work being dressed inside. Table has a removable throat ring. Miter gauge and clamp attachment, too, for safety and accuracy on end shaping.

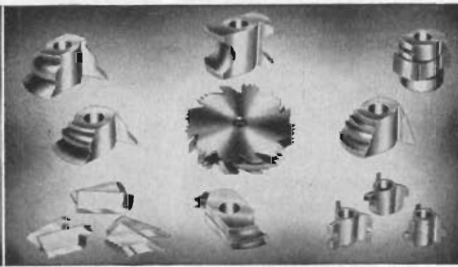

Large cutters, small 3-wing cutters, sash cutters, bevel edged knives, dado heads, grooving and slitting saws, jointer heads—are all instantly useable.

No. 843 Dado Head 6" x 1 1/8" 3/4" bore



Table-wing extension makes table 28 x 27 1/2 inches, with 19 1/4" in front of spindle to firmly support wide panels, and long pieces being end-shaped. Center hand-wheel of fence moves both fence-plates forward or back together. The side wheels move each fence-plate independently.

Motor mounted on pivoted bracket. Quick locking screw sets and maintains proper belt tension.

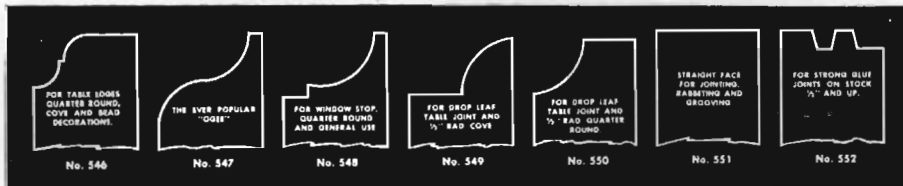

Above are Bevel Edged Knives. Every shape of high decorative value. These knives have extra clearance, cut fast and clean. Leave no splinters or feathery edges. Easy to use. Versatile. Any part of shaper usable alone, and only one size collar needed. Sharpened.

Nos. 546, 547, 548, 549, 550, 551, 552, Bevel edged Shaper Knives. Price of each pattern, per set of 2 knives. Ship. wt. 8 oz.
No. 555 Complete set of 7 pairs

No. 2136 Table-Wing Ship. wt. 35 lbs.
No. 2132 Inner Table-Ring. Ship. wt. 2 lbs.
No. 2106 Belt Guard. Ship. wt. 12 lbs.

Boice Crane

TRU-FORM PRODUCTION TYPE SHAPER CUTTERS

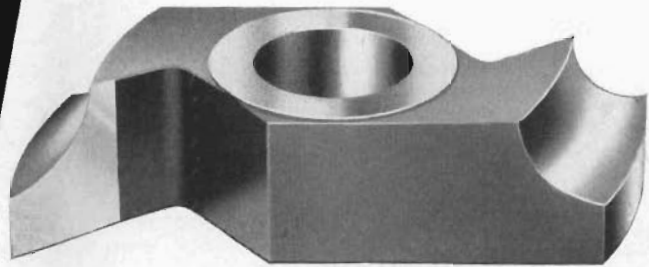

No. 405

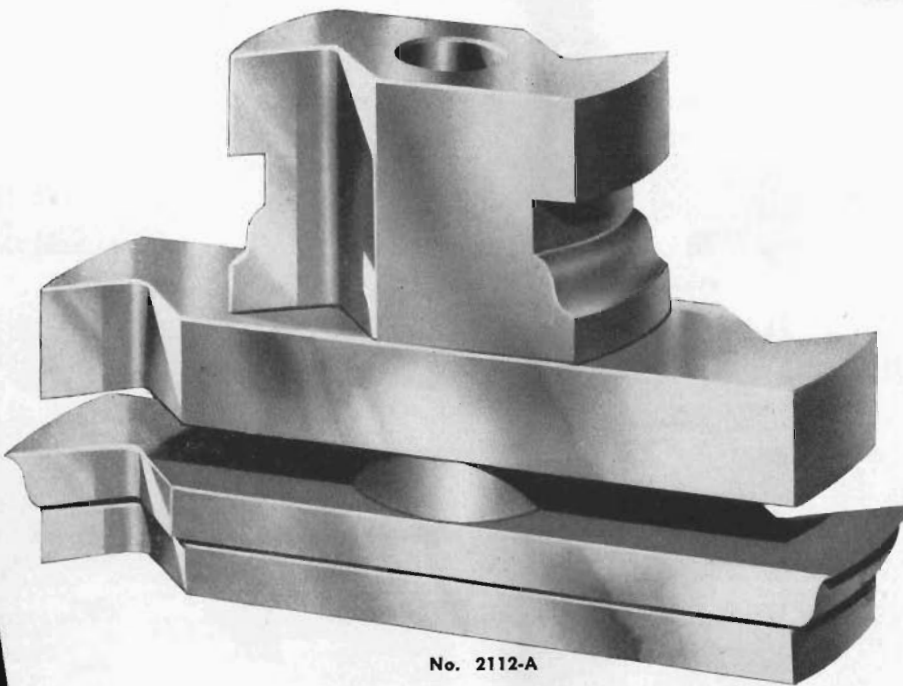

No. 2112-A

BOICE-CRANE POWER TOOLS

CUTTING • SHAPING • DRILLING • FINISHING
WOOD METAL FIBRE PLASTICS
IN INDUSTRY • SCHOOLS • HOME SHOPS

BOICE - CRANE COMPANY
930 W. CENTRAL • TOLEDO 6, OHIO

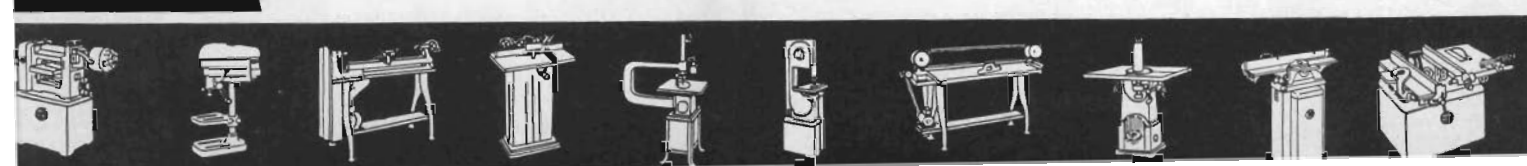

Boice Crane

TRU-FORM PRODUCTION TYPE SHAPER CUTTERS

Another Boice-Crane "first." Here are the first real production type wing cutters at moderate prices, with costlier, but better, circular or involute relief,* which assures six important operating advantages. Our new method machines the shape into the cutter on an arc that makes them cut cleaner, faster, without burning. More foolproof. Easier to use. Much safer than old-style flat knives.

1. Freer, cleaner, more burn-free cutting.
2. Cut the true, original shape and dimensions as long as the cutter lasts.
3. Larger rake angle eliminates laggy, scraping cuts. Instead a clean, shaving cut without vibration.
4. Up to 50% more usable cutter life.
5. Adequate clearance for successful, high speed shaping with today's faster spindles.
6. TRU-FORM tooth design eliminates cutting edge crumbling and break down. Dissipates heat faster.

Fine tungsten tool steel. Deep, uniform hardening. Precision formed. Razor sharp. Authentic, full-sized commercial patterns. Average cutting circle of 3 1/4" makes them outperform smaller diameter cutters. Bores to fit most any shaper.

Packed with cutting edges protected. Copyrighted resharpening "Check-Chart" packed with each cutter and cutter set.

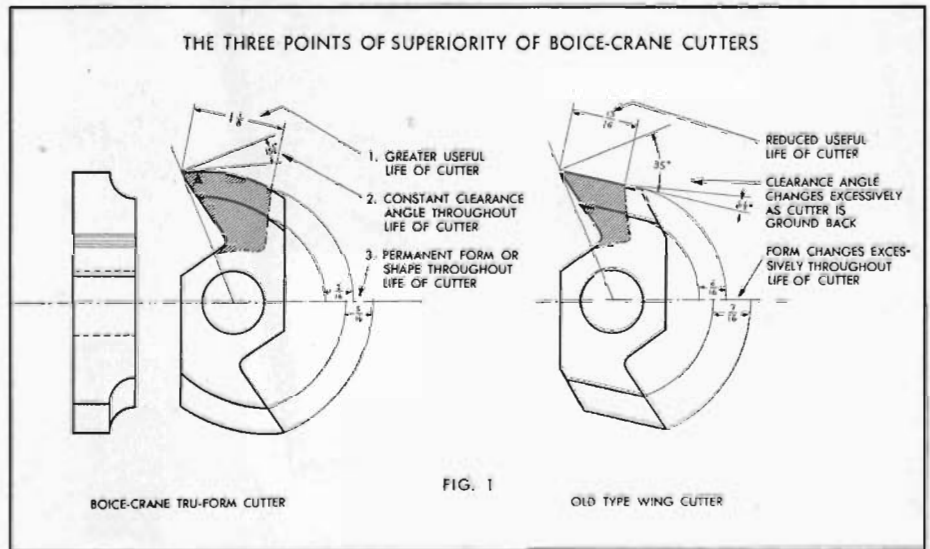

HALF-SIZE STANDARD SHAPE LIST

Remember, these cutters produce work TWICE the size shown below. Don't confuse with small ones offered with light-duty machines with undersized spindles. See full-size illustration at top of page 5.

All average 3 1/4" diameter. Many do several jobs—not just one. See Fig. 2. Stock bores at regular prices are 1/2", 5/8" and 3/4". Send accurate sketch for prices on special shapes not listed.

* Also called flattened-arc relief; cam-profiled relief.



FIG. 2. ILLUSTRATES TYPICAL CUTTER (No. 422) USED FOR MORE THAN ONE CUT.

No. 401	*No. 403—1/4" RAD.	No. 405—1/4" RAD.	No. 406—7/16" RAD.	No. 407—1/2" RAD.	No. 408	No. 410	No. 412—1/4" RAD.	No. 414—1/4" RAD.
No. 415—7/16" RAD.	No. 416—1/2" RAD.	No. 418	No. 475	No. 419	No. 420—9/16" RAD.	No. 421—1/4" RAD.	No. 422—1/4" RAD.	No. 423—1/4" WIDE
No. 424	No. 432	No. 427	No. 425—1/4" RAD.	No. 434	No. 442—SCREEN MOLD	No. 476	No. 486—1/4" RAD.	No. 487—1/4" RAD.
No. 470	No. 413—5/16" RAD.	No. 404—5/16" RAD.	No. 417—1/4" RAD.	No. 478—SHOE MOULD	No. 485—5/16" RAD.			
No. 443 1/2—3/4" DIA.	No. 435	No. 441 GLUE JOINT	Top No. 479 BOTTOM No. 480 COMMERCIAL REFRIGERATOR DOORS	No. 440—1/4" RAD.	Top No. 401 BOTTOM No. 405 For 1/4" LIP CUPBOARD DOORS, 1/4" OR THICKER	No. 492—1/2" RAD. NOSING CUTTER— STAIR TREADS, ETC.	No. 489—9/16" RAD. NOSING CUTTER— STAIR TREADS, ETC.	No. 493 STAIR TREAD CUTTER—ALL THICKNESSES TO 1 1/2"

(* No. 403—1/4" RADIUS, ALSO HAS SIMILAR SHAPE 3/16" RADIUS ON SAME CUTTER.

Above Cutter Illustrations 1/2 Size

CABINET CUTTER SETS

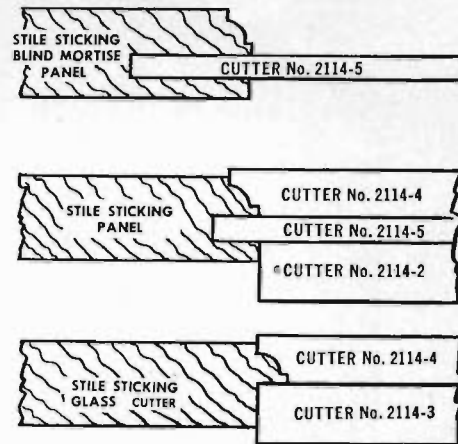
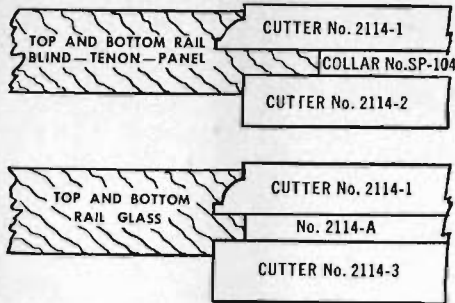

These Cabinet Sets are handy, easy to set up and use. Do hundreds of shaping, edge sticking, grooving and coping jobs on cabinet and furniture work. Other small, thin wing cutters don't compare. Thick wings last scores of regrinds—never change shape. High peripheral speed.

No. 2113 OGEE Cabinet Set. 4 cutters 4½" dia. and collar. ⅝" and ¾" bores. Packed in attractive wood box. Ship. Wt. 4½ lbs.

No. 2114 OVULO Cabinet Set. 5 cutters 4½" dia. and collar. For standard millwork. Use only on Boice-Crane and other shapers with large spindles. ⅝" and ¾" bores. Packed in wood box. Ship. Wt. 5 lbs.

MOLDING AND COPING CUTTERS

Make fine commercial grade doors with your shaper. Three sizes for common rail thicknesses. Two patterns—OGEE and COVE and BEAD. Same cutters used for sticking, also coping rails. Specify right or left rotation, or matched pair.

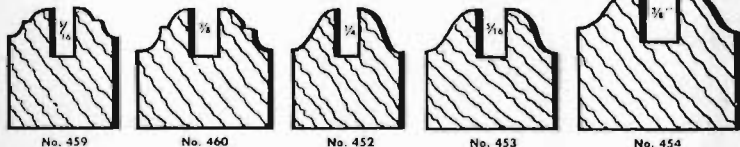
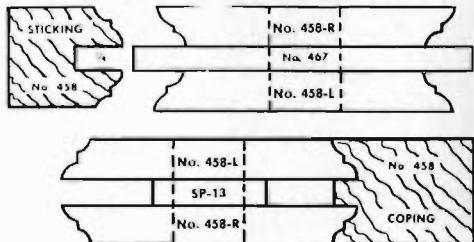

CUTTER or COLLAR	PURPOSE	BORES AT REGULAR PRICE	SHIPPING WEIGHT	PRICE
OGEE COVE & BEAD				
452 458	Stick and Cope 1½" Doors	½", ⅝", ¾"	8 oz.	
453 459	Stick and Cope 1⅜" Doors	½", ⅝", ¾"	10 oz.	
454 460	Stick and Cope 1¾" Doors	½", ⅝", ¾"	12 oz.	
467 Square	Groove for ¼" Panel	½", ⅝", ¾"	6 oz.	
468 Square	Groove for ⅝" Panel	½", ⅝", ¾"	8 oz.	
469 Square	Groove for ¾" Panel	½", ⅝", ¾"	10 oz.	
470 Square	Groove for 1½" Panel	½", ⅝", ¾"	12 oz.	
SP-13 Collar, 1⅜" dia.	Tongue on ¼" Panel	½", ⅝", ¾"	4 oz.	
SP-14 Collar, 1⅜" dia.	Tongue on ⅝" Panel	½", ⅝", ¾"	5 oz.	
SP-15 Collar, 1⅜" dia.	Tongue on ¾" Panel	½", ⅝", ¾"	6 oz.	
SP-106 Collar, 1⅜" dia.	Tongue on 1½" Panel	½", ⅝", ¾"	10 oz.	

BOICE-CRANE CUTTERS for SCREENMAKING

Make an all-around better screen that sells easily. Produce a longer, stronger, close fitting tenon corner joint. A heavy-duty Boice-Crane Shaper, plus a pair of these cutters will bring steady income. Every job installed will sell another. See Fig. 3, next column.

No. 461 Cutter, 5½" dia. x ⅜". ⅝" or ¾" bore. Ship. wt. 12 oz.
No. SP-103 Collar, ⅜" thick. ⅝" or ¾" bore. Ship. wt. 4 oz.

KNIVES IN PAIRS . . FOR ECONOMY

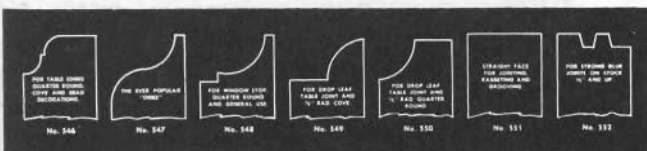

Economical for occasional use or short runs. High speed steel. Sharpened, honed, hardened. Cut fast, clean, no feather edges. Easy to use. No special collars needed. Nos. 549 and 550 popular for drop leaf table joint as shown.

Nos. 546, 547, 548, 549, 550, 551, 552. Per pair, shipping weight 4 oz. No. 555 Set of all 7 pairs. Shipping weight 1½ lbs.



SASH CUTTER SETS

These are complete sets with genuine Boice-Crane Tru-Form features to produce top quality, commercial grade single and double hung sash products with or without check-rail. Make sash from 1⅞", 1⅜", or 1¼" stock using ⅝" Ogee and ⅜" tenon. Fine tungsten tool steel. Involute relief for free cutting.

IMPORTANT NOTE. These large commercial millwork type cutters recommended only for BOICE-CRANE 7200 r.p.m. shapers, or others with spindles guaranteed to handle cutters up to 6" diameter. Do not run at speeds above 7200 r.p.m.'s.

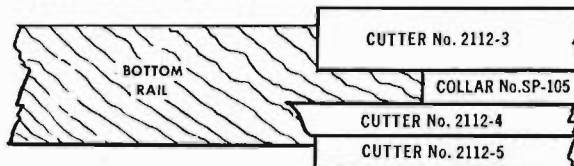

No. 2111 Sash Cutter Set. Five cutters, collar, instructions, regrinding "Check-charts." (Similar to 2112A, page 5, except 2 wide sticking cutters instead of one). Makes Western style common and check-rail windows with putty groove. ⅝" and ¾" bores. Ship. Wt. 7½ lbs.

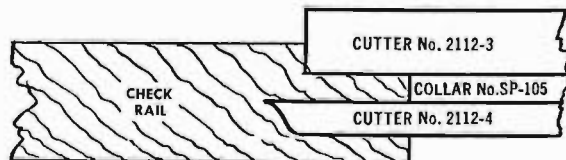

No. 2112A Same as 2111 except 1 less sticking cutter. (See page 5). Makes Ohio style common and check-rail windows. (No sticking on lower check-rail). ⅝" and ¾" bores. Ship. Wt. 6½ lbs.

BOICE-CRANE PANEL RAISER CUTTER AND SHAPER MAKE COMMERCIAL GRADE PANELLED DOORS

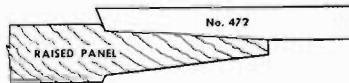

Here is another practical, full mill-size BOICE-CRANE cutter that will make you money. If your shaper has a heavy-duty spindle guaranteed to swing cutters larger than 3½" diameter like a BOICE-CRANE No. 2100 will, this cutter will raise your door panels. Equals panels run on a moulder.

No. 472 Panel Raiser Cutter, 6¼" dia. Standard bores ⅝" and ¾". 10% extra for 1" bore. Ship. Wt. 8 oz.

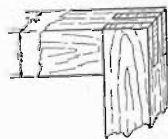
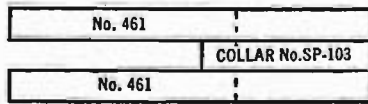

Fig. 3

CUTTERS for EVERY PURPOSE

The Knives listed in this catalog do not constitute all of the cutters we can furnish for BOICE-CRANE and other make shapers. Write us if your requirements are not covered by listed items—sending sketches of shapes you need. We will quote you on special cutters for one-way or reversible operation.

BOICE-CRANE CO., Toledo, Ohio

BOICE-CRANE NO. 1400-A SIX-INCH JOINTER

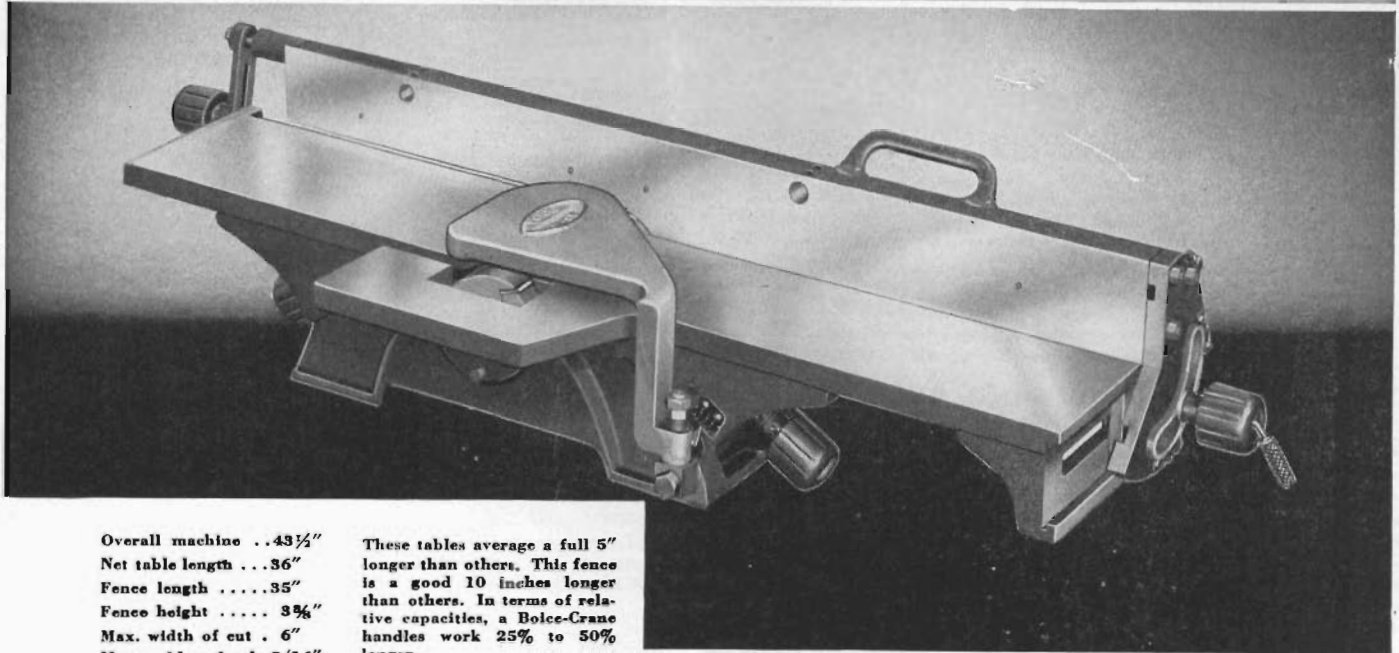

Overall machine . . . 43 1/2"
 Net table length . . . 36"
 Fence length 35"
 Fence height 3 3/8"
 Max. width of cut . 6"
 Max. rabbet depth 9/16"

These tables average a full 5" longer than others. This fence is a good 10 inches longer than others. In terms of relative capacities, a Boice-Crane handles work 25% to 50% longer.

FOUR Models to Choose From

BELTED MOTOR DRIVE — IN BENCH AND FLOOR TYPES
DIRECT MOTOR DRIVE — IN BENCH AND FLOOR TYPES

This big, sturdy, extra long 6-Inch Jointer, which is built and operates with remarkable accuracy, is chosen more often than any other make by those men who know and want good tools. This overwhelming preference arises from the superior, basic design and specifications of the Boice-Crane,—plus our highly refined quality and the fact that Boice-Crane Jointers are available to you in FOUR different models of which one is sure to meet your every need.

When you buy any 6-inch jointer, you do so primarily because you want to joint long stock, and therefore need long tables. However, long tables alone are not enough. Fully 90% of all your jointing, such as all edge jointing, face jointing, bevelling, rabbeting, etc., must be fence guided. Consequently, it is important to purchase a Boice-Crane Jointer that has long tables, and also a long rigid fence.

Boice-Crane's 6-inch Jointer embodies both of these valuable features, which enables the jointing of longer lengths, and also makes it possible for even the most unskilled operator to feed lumber with utmost ease and steadiness. Makes every cut accurate through its full length, even on 6, 8, and 12-foot lumber, doors, sash, etc.

Boice-Crane's 3" diameter cutterhead is the largest found in any low priced 6-inch jointer we have ever heard of. This makes possible a freer cutting "rake-angle" to knives, for a chatterless and much smoother shearing cut in the direction of the wood fibers—rather than the chipping and chattering cut across the wood-fibers occurring with a smaller diameter cutterhead.

These 3 factors: longer tables; longer and more rigid double-locked fence; and bigger diameter cutterhead—are accountable for the better performance of Boice-Crane 6-Inch Jointers.

No matter whether you purchase a Boice-Crane in belted or in direct-motor drive, you can't beat Boice-Crane jointing.



The rear end of fence is locked just as rigidly as the front.
 See how far backward your left hand can travel and still be abreast our solid fence.
 Boice-Crane gives fullest, longest control to lumber.

Long Tables, with equally long fence tilted over bevelled work—and with fence locked AT BOTH ENDS—with your hands wide apart—makes accurate bevelling a pleasure not a chore. The ONLY Fence that is 100% rigid.



No. 1420 Belted-Motor-Drive Jointer
 Steel Cabinet contains and guards 1750 r.p.m. motor, belt, and pulleys. Built-in dust chute shields motor by discharging shavings out the side. Handsomely styled. Belt and pulley guard panel for rear optional.

No. 1400A 6-Inch Ball Bearing Jointer with fence, 3-knife head, safety guard, and 2 1/2" dia. V-pulley for belt drive. Ship. wt. 130 lbs.

No. 1015 5" dia. V-pulley for motor, 3/4" bore. Shipping weight 1 lb ...
No. 1058 V-belt, 58" circumference. Shipping weight 8 oz.
No. 1408 Cabinet Floor Stand, chute and motor-bracket. Ship. wt. 105 lbs.

No. 1415 Motor 1/2 h.p., 1750 r.p.m., Repulsion-Induction. Ball-bearing, 110-220 volt, 60 cycle, 1 phase A.C., including cord, plug, and a special 2-pole switch that mounts flush on side of cabinet. Ship. wt. 67 lbs.

No. 1420 Complete Floor Model, 6-Inch Jointer with belted-motor-drive, as itemized above. Shipping weight 305 lbs.

No. 1401 Steel, open, leg type stand. ship. wt. 25 lbs.
No. 1407 Special Rear-Knife Safety Guard. Shipping weight, 3 lbs.
No. 1409 Belt and Pulley Guard Panel for No. 1408 Stand. Ship. wt. 30 lbs.
No. 1417 Motor 3/4 h.p., otherwise same as No. 1415 motor. Ship. wt. 67 lbs.

NOW! THIS DIRECT-DRIVE JOINTER AT PRICES OTHERS ASK FOR BELT-DRIVE

Operates on standard 60 cycle AC electric current! This Boice-Crane Direct-Motor-Drive Jointer is superior in every way to any belted-motor drive . . . and here are a few important reasons why:

Direct-Motor-Drive is the most efficient. All motor-power goes directly into cutterhead. No belts to slip, replace, nor to guard.

Boice-Crane's cabinet catches all shavings . . . keeps your shop-floor clean and tidy. The accumulated shavings are removed through the large hinged door at rear of cabinet, whenever convenient. Most cabinets just discharge shavings out upon the floor.

In Boice-Crane, you get a big $\frac{3}{4}$ H.P., 3450 r.p.m., Direct-Drive Motor, for the same money you would expect to pay in all for a belt, motor-pulley, and a less powerful $\frac{1}{2}$ h.p., 1750 r.p.m. motor. Boice-Crane gives MORE horse-power for the money!

The new Boice Crane $18\frac{1}{2}$ " x $23\frac{1}{2}$ " Cabinet Base has sleek, modern lines. Its heavy steel sides and top are welded into a single unit that is exceptionally strong and stiff, and allows no vibration in machine. Yet, it costs little more than open-type belt-drive stands.

All in all . . . Boice-Crane, Direct-Motor-Driven Jointers are ideal for all classes of woodworking shops . . . schools, home shops, and industries. For 60 cycle AC current, we recommend this new, efficient, clean, safe and low cost Direct-Motor Drive.

No. 1425 Bench Model. Direct-Motor-Drive 6" Jointer complete with No. 497 Motor, $\frac{3}{4}$ H.P., 3450 r.p.m., ball-bearing Repulsion-Induction. 60 cycle, 1 phase, A.C., for 110 or 220 volt, includes switch. Shipping weight, 230 lbs. . .

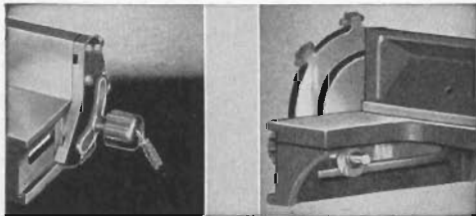

Right. Fence tilts on circular trunnion machined into rear of bracket. Makes degree scale accurate. *Left.* Lateral movement is on tongue and grooved cross-slide. Free sliding. Patented dual locks at front. Act independently. Handy. Patented "Auto-set" stops for 45, 90, and 135 degrees.

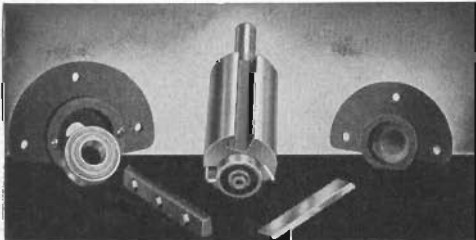

Bearing Housings anchored by 3 cap screws each. Can not loosen. Two life lubricated ball-bearings. Larger 3" diameter cutterhead with greater "rake" angle to knives is chatterless even on deep cuts. Joints smoother than smaller heads.



Spring Hold-Downs for safe feeding of short or thin materials. Keeps hands away from cutterhead. Also holds long lumber down while you feed from a position several feet distant from machine. Convenient "Hand-Hold" on fence facilitates easy tilting or lateral movements. Fence has 4 holes for attaching wood facings.

No. 1403 Set of 2 Spring Hold-Downs. Ship. wt. 3 lbs.
No. 1402 Set of 5 high speed jointer Knives, 6". Ship. wt. $1\frac{1}{2}$ -oz.

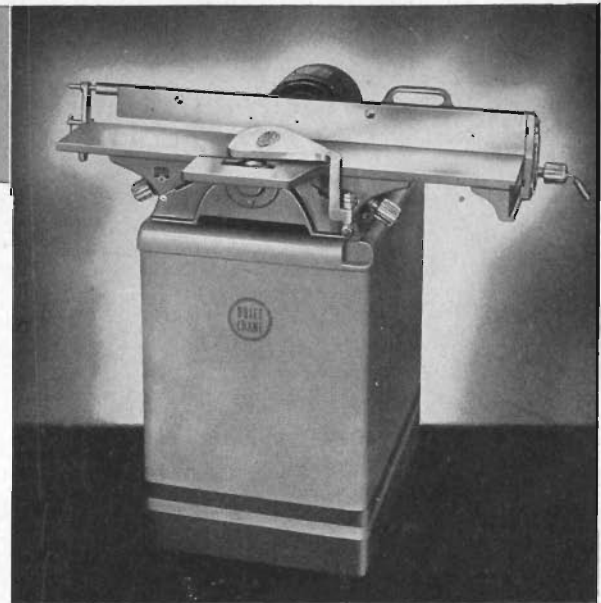

No. 1430 Floor Model, Direct-Motor-Drive Jointer, as shown above, complete with same motor No. 497 of $\frac{3}{4}$ h.p., including switch, and cabinet base hinged door at rear. Ship. wt. 340 lbs.

No. 1433 Jointer, same as No. 1430, except with a 3-PHASE, $\frac{3}{4}$ h.p. motor, 220-440 volt, 60 cycle, and 3-phase switch.

FENCE HAS REAR LOCK

This patented Rear Fence Lock makes fence so extremely rigid that even six times the ordinary feed pressure cannot spring it backwards. Now, full jointing accuracy is a certainty. On bevel cuts, with fence tilted over work, fence can never lift upwards either. Takes but a half second to lock. Makes all jointing easier and better.

Two-end fence locks have proved best on power saws—one lock never is rigid. Same is doubly true in jointers because jointer-fences are much longer, and must withstand heavier strains. Therefore insist on Boice-Crane, the only 6-Inch Jointer featuring two-end fence locks.

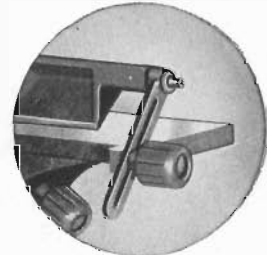

THIS KNIFE GUARD HAS DOUBLE-PIVOT ACTION

The vertical pivot allows guard to open and shut over knives. Torsion spring keeps guard closed against fence or work. The horizontal pivot lets guard be swung entirely below table, as shown, to permit rabbeting to be done. Guard remains bolted all the while to machine. To replace guard into regular guarding position, just a slight flip and the guard snaps entirely shut over knives. No fitting. No fussing as on ordinary one-pivot guards.



FULLY GUARDED CUTTER

With Cutter-Head Guards covering knives both in front and behind fence, as shown, no portion of the knives remains exposed when fence is moved forward across tables. Here is fullest possible safety to the operator and also to passers-by. Ideal for industrial and school shops.



Patent Nos.
 1,927,477
 1,967,791
 2,049,044
 2,049,045

Others
 Pending

RIGID LONG FENCE VASTLY IMPROVES JOINTING!

Long 35-Inch Guiding Zone eliminates difficulties in feeding lumber with accuracy. Long fence gives long firm guidance. Allows wide spacing of your hands so you always get firmest possible grip and leverage on lumber. Feeding of lumber made easier, better and steadier. No more judging "by eye" the steadiness of feed, as on short fenced jointers. No other jointer has a long, and rigid fence like this.

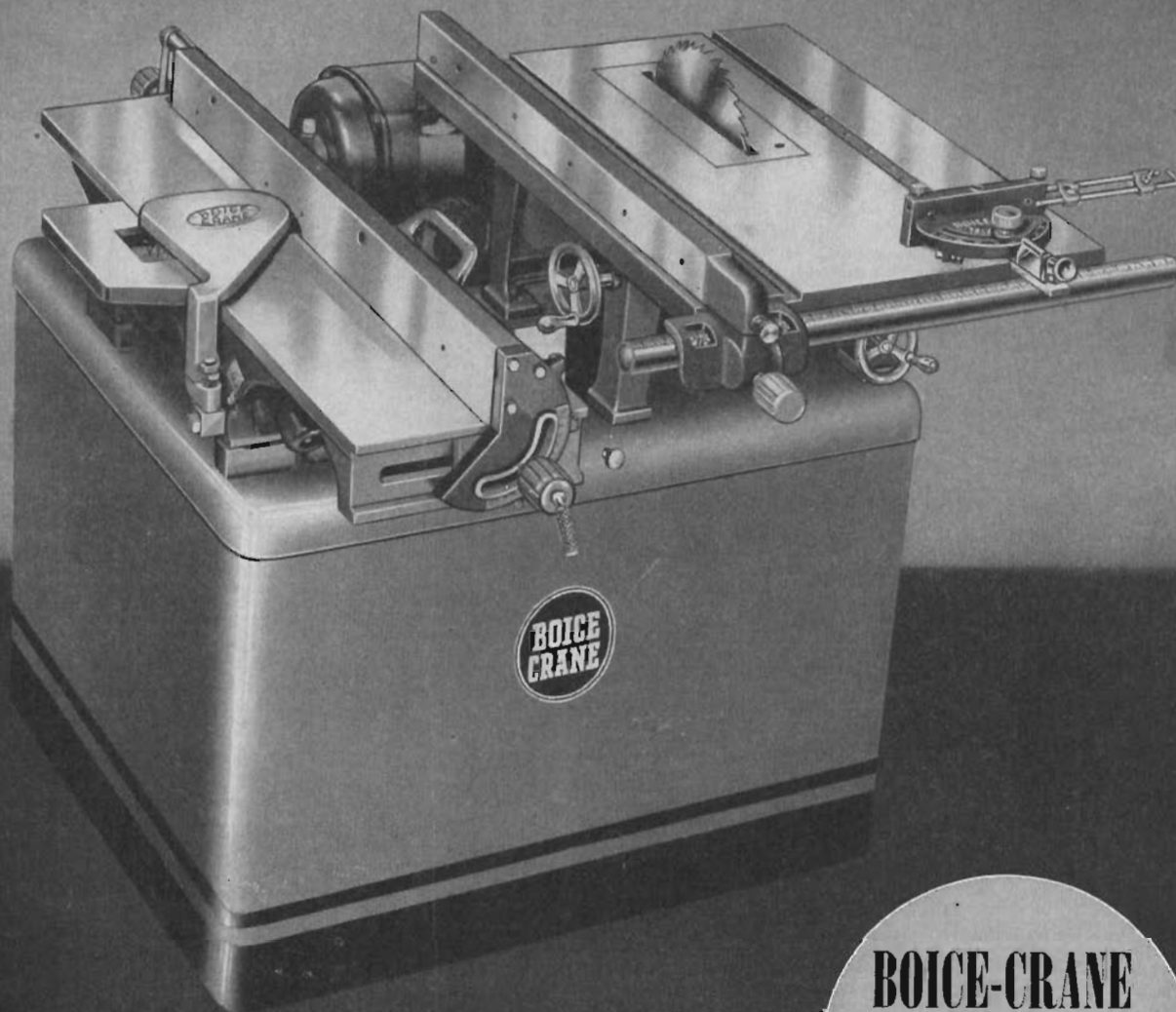

BOICE-CRANE

No. 2529

SAW-JOINTER

**SAVE THE PRICE OF ONE MOTOR!
BUY THIS 10" TILT ARBOR SAW—6" JOINTER UNIT**

Here is a complete workshop in itself . . . Boice-Crane's No. 1400A 6-Inch Jointer, and No. 2500 Tilting-Arbor Saw . . . compactly mounted together on a steel floor stand . . . both driven by one motor. Very popular and practical among all classes of woodworkers, school shops, industrial plants, even home shops.

In industrial plants where space is costly and at a premium—it is practical to install this compact, combination Boice-Crane Saw-Jointer. Uses only one motor—and that is economy.

The Jointer has long tables, and an unusually long fence, which locks at both ends. Other details are fully illustrated on pages 8 and 9. No better jointer at the price.

The Boice-Crane 10-Inch Tilting-Arbor Saw is the latest design "tilting-arbor" type whose own unbeatable performance is further enhanced by combination with 6-inch jointer like this. Your two most used machines are side by side. Convenient. Compact. No interference. *Choice of motors to 1½ h.p., see page 41. Choice of steel cabinet base as shown, or, less expensive, open, leg type stand.*

No. 2500	Tilting-Arbor Saw with V-belt.....
No. 2511	Rolling Pulley, 5½" dia.....
No. 1400A	6" Jointer with guard.....
No. 1015	V-Pulley, 5" dia.....
No. 1037	V-Belt 37" circumference.....
No. 2586	Motor, 1 h.p., 2-shaft, with push-pull switch

No. 2549 Cabinet Base, switch rod. Ship. wt. 170 lbs.

No. 2529 Saw-Jointer complete as above for 110 v., 60 cy., 1 ph., A.C. Ship. wt. 565 lbs.

No. 2509 Steel, open, leg type stand, switch rod. Ship. wt. 98 lbs.

Other Motors page 41. **Recommended for Medium Duty**, Nos. 2576, 2578, 888; **Heavy Duty**, Nos. 2586, 2588, 2596, 2598, 890, 892.

BOICE-CRANE

No. 2500

TILTING ARBOR SAW

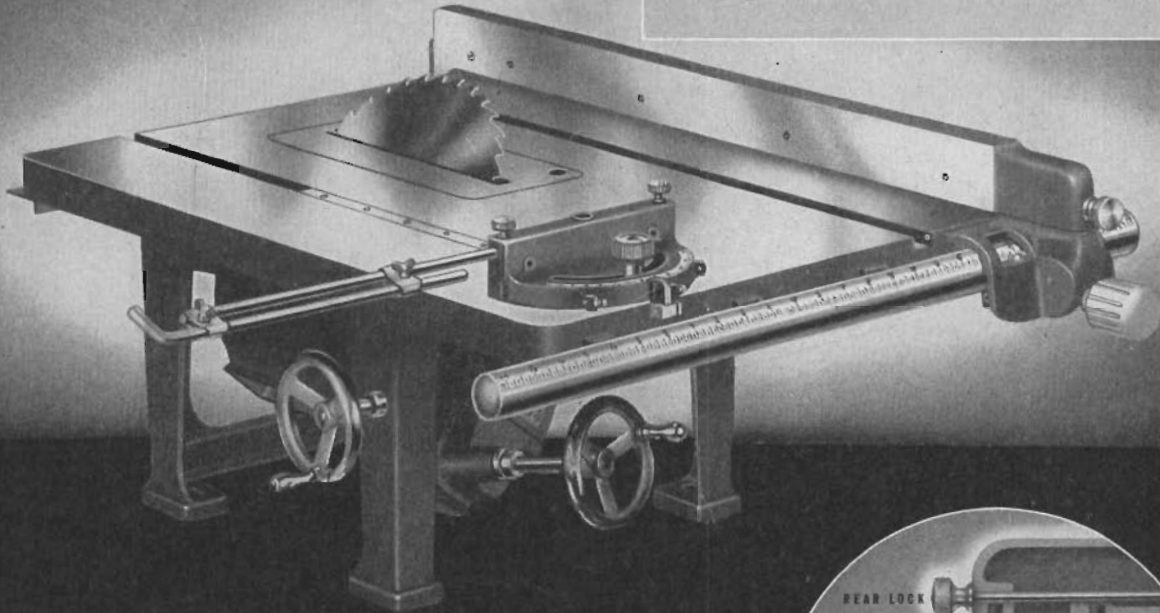

NOW *You Can Have* PERFECT SAWING PERFORMANCE

When Boice-Crane announced the very first, low cost Tilting-Arbor Saw, we incorporated big oversize ball bearings and a large oversize diameter saw-arbor . . . to stand punishing service sawing with big 10-inch blades. To this day, Boice-Crane saws have far greater overload capacity than other ordinary saws.

In its present perfection, you may feel confident that this Boice-Crane Tilting-Arbor is a more finely constructed, and a far superior performing machine than is being offered today at anywhere near our low price.

Every detail in both construction and performance has been "Shop-Tested" and its worth proved by thousands of installations in the better shops throughout the entire world. In Boice-Crane, you get more highly refined construction, longer lived materials (no die-castings in any part subject to wear), bigger and more costly ball bearings, bigger and stronger arbor, heavier all cast-iron rip fence, and many more fine features . . . all of which gives you super-accuracy on every conceivable saw-cut . . . all with greater economy in first cost, as well as in upkeep over a long period of years.

And no other Tilting-Arbor Saw allows you to make the BIG ECONOMY of driving a big capacity saw by a low cost "standard" motor, or of driving BOTH this SAW and a 6-inch JOINTER with just one, "standard" low cost motor.

-
- No. 2500** Boice-Crane Tilting and Lowering Arbor Saw with Ball Bearings. Includes "micro-set" ripping fence, combination extension bars, "auto-set" miter gauge, one 10-inch diameter rip blade (or cut-off or combination saw), 42" circumference V-belt, and arbor pulley for V-belt drive. Ship. wt. 160 lbs.
- No. 2511** Rolling Drive Pulley, 5½" dia. for 1750 r.p.m. motors. Specify size of shaft, ½", ⅝" or ¾". Ship. wt. 5 lbs.
- No. 702** Same as No. 2511 except 3¼" for 3450 r.p.m. motors.

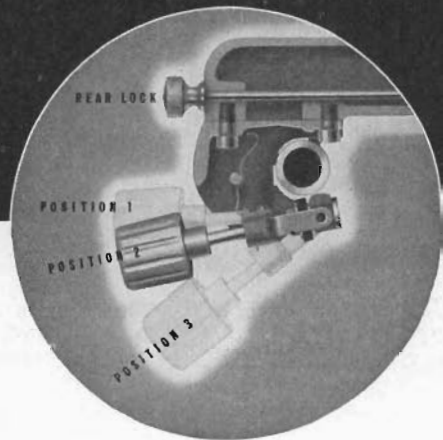

ONE KNOB FENCE CONTROL

You will like the amazing ease, and the built-in convenience in Boice-Crane's ONE-KNOB Fence Control. It's lightning fast and accurate. To operate, you lift knob to 2nd position for rapid traverse; to 1st position for alignment and micro-set; and drop knob down to 3rd position to lock fence in a positively slip-proof bull dog grip. Once you see it, you'll want this better One-Knob control.

The very instant you bring the micro-set, feed-wheel of a Boice-Crane Fence into play . . . and before you can even micro-set the fence by a hair's breadth . . . our fence is *automatically aligned parallel to blade*. It stays parallel too, throughout the feeding because in the Boice-Crane One-Knob Fence Control, the micro-set feed-wheel (see above cut-away) contacts the bar at a spot which is diametrically opposite the mid-way point between the 4 bearing pads of the fence bracket.

No lag whatsoever exists at the rear of Boice-Crane Fences. Every Boice-Crane scale reading indicates accurately the exact distance from any point along the fence to blade, as though measured at the very blade itself.

Only in Boice-Crane, does fence align as it micro-sets. Only in Boice-Crane is all fence "lag" removed at the very start. And only in Boice-Crane, do you secure fence settings that coincide *every time* to the accurate scale furnished . . . at the very first lock-up.

CONTROLS, LOCKS AND GAUGES

All at your fingertips

- 1 Hand Lever locks angular position of saw-arbor by directly clamping the two large trunnion faces solidly together. Direct action locks hold best.
- 2 Adjustable, "Auto-set" screw to stop tilt of blade exactly at 45 degrees. A similar screw is provided for 90°. Once set, always set.
- 3 Rotating Handle Crank very conveniently placed to tilt saw arbor. Ample clearance around it. No skinned knuckles.
- 4 Degree Dial indicates all angles to a "split-hair" degree of accuracy.
- 5 Steel worm, and cast-iron worm-wheel segment tilt saw-arbor. Both are machine-cut to last a lifetime.
- 6 Another Rotating Handle Crank. This one raises or lowers *saw-arbor* (table remains stationary).
- 7 Large Dust Chute of cast-iron encloses lower portion of blade. Discharges sawdust downward—away from motor.
- 8 Totally enclosed Gear Box keeps the spiral gears out of flying sawdust. Box is grease packed, for a lifetime of service.
- 9 Hand Lever locks vertical position of saw-arbor. This lock acts directly on the gibbed dovetail slide casting. Never slips.

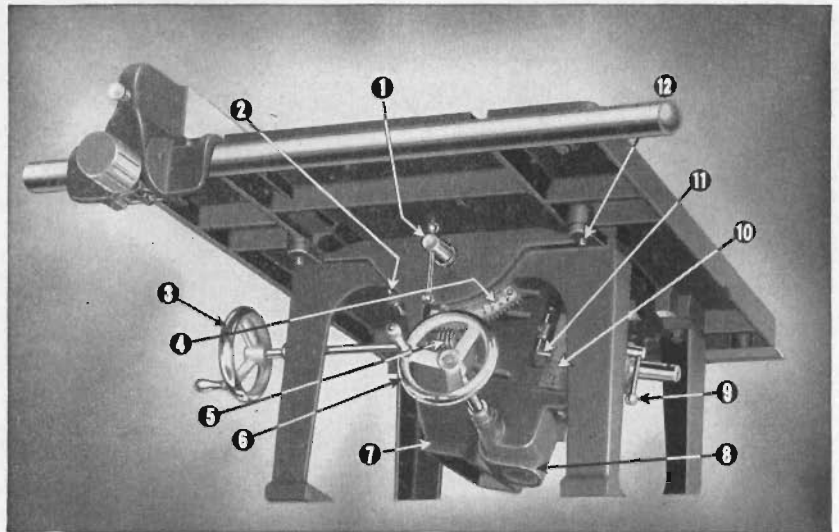

NO OTHER HAS THESE 12 FEATURES

- 10 Accurate Vertical Scale, fully visible, indicates exact depth of cut. No need to stop machine to measure saw-projection with a rule.
- 11 Pointer for depth-of-cut. Adjusts for different projections of 6, 8, or 10-inch blades.
- 12 Large taper dowel pins maintain exact position of the front trunnion casting. Never can shift out of alignment.

Both hand cranks shown above, feature *Rotating Handles*.

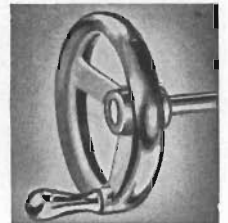

Now you can actually keep firm grip on handle while you spin crank. Makes all adjustments faster and easier. Your hand won't heat up, or blister. Order several for your *other* machines.

Your every convenience is provided for in most masterful fashion in Boice-Crane.

Protected by patents 1,922,151, 1,894,010, 1,902,270, 2,166,703, 2,256,607 and others pending.

No. 2508 Cranks. Hole size $\frac{3}{8}$ " or $\frac{1}{2}$ ". Ship. wt. 1½ lbs.

BIGGER BEARINGS AND ARBOR FOR GREATER OVERLOAD CAPACITY

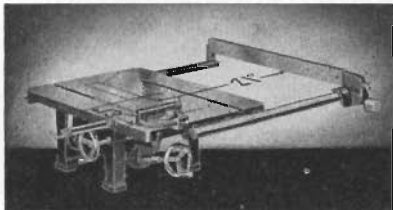
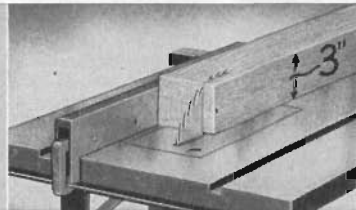
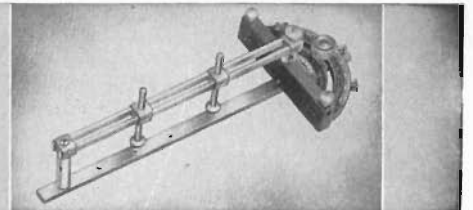

Table Bars may be centered on ordinary work (to save space or annoyance of protruding bars) or may be instantly extended to 21-inch capacity, as shown. A wood table-extension may be readily attached to both bars. You won't find these 3 features in other saws.



10-Inch blade cuts 3" stock. Makes 45° miter thru standard 2 x 4's. Practical capacity for industrial users. 8-Inch blade, recommended for lighter work, cuts thru 2" stock. Lowers entirely below table. Thinnest stock sawed with a minimum of saw-projection. Safe.



This practical Clamp Attachment (for miter gauge) holds work from creeping away from blade. It insures accuracy on difficult-to-hold, miter cuts. One job saved from spoilage pays for it. Pat. 1,894,010.

No. 2503 Clamp Attachment.

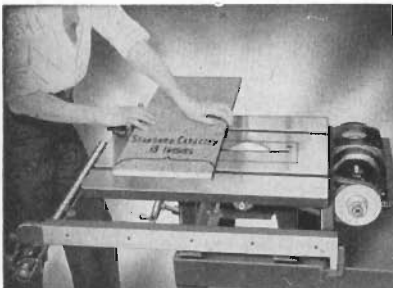

Wide "working zone" in front of blade makes cross-cutting of 13-inch wide stock easy. Miter gauge rests entirely on table. Ample $\frac{5}{8}$ " table space behind blade, for outfeed support. Table measures 20" x 27½".

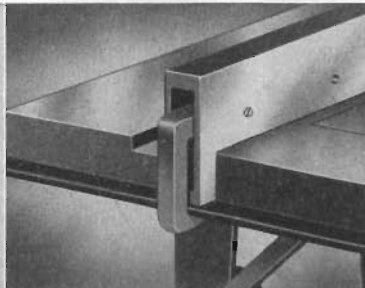

Rear Fence Locking finger is operated from front of fence to eliminate reaching over blade. Safe and handy. Fence can't spring away from blade. Accuracy assured on even heaviest work. Finely graduated scale.

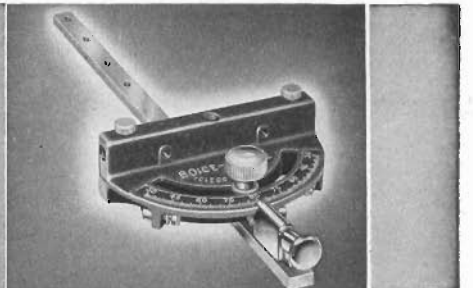

"Auto Set" Miter Gauge. Adjustable tapered pivot-pin removes wear, maintains accuracy. "Auto-set" stop screws for 45, 90 and 135-degree angles. Accurate for a lifetime. No. 2502 Auto Set Miter Gauge. Pat. No. 1,902,270. Shipping weight 4¾ lbs.

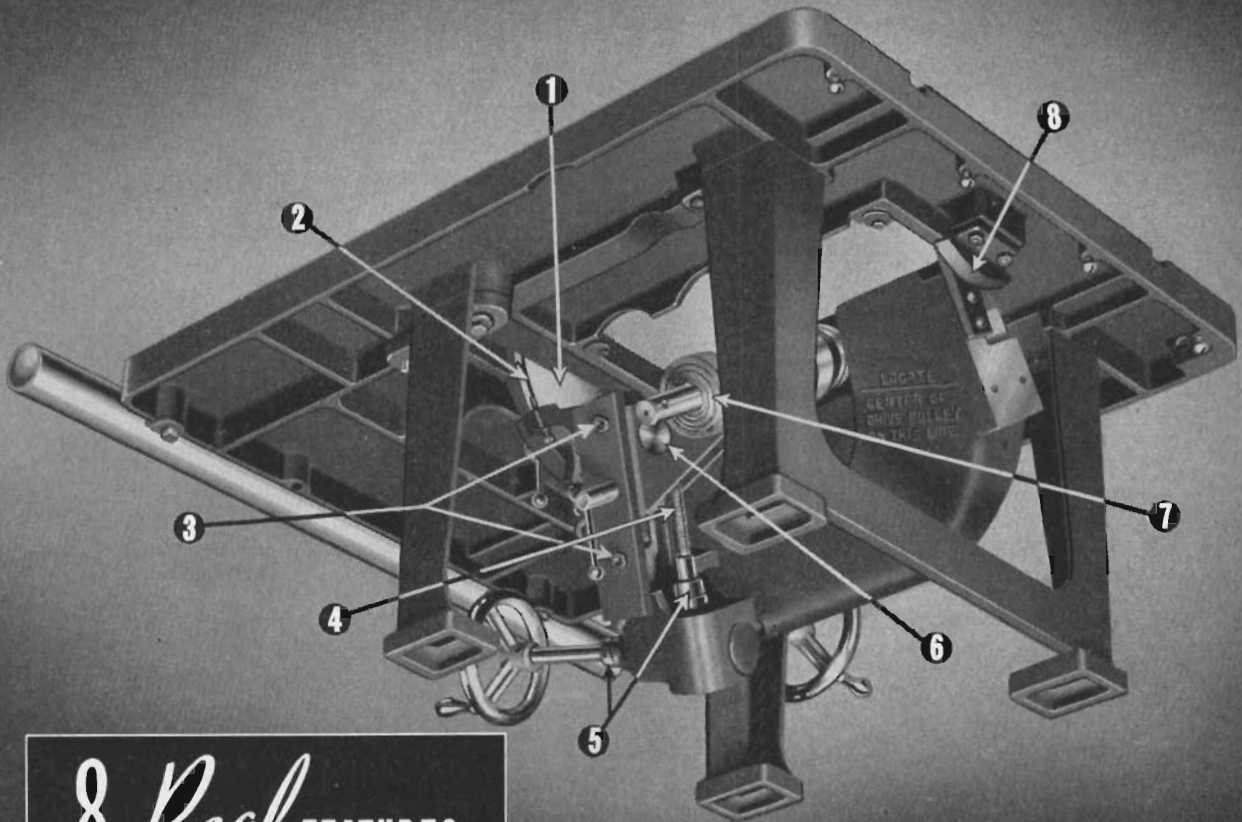

8 Real FEATURES YOU CAN'T OVERLOOK

- 1—Extra large trunnion surface for true saw blade alignment.
- 2—Circular, tongue and grooved ways machined from solid cast-iron. Blade at every setting intersects table on same line. "Inch Scale" readings always true and dependable.
- 3—Adjusting screws with jam nuts tighten gib of dovetail way to any friction wanted.
- 4—Acme thread elevating screw.
- 5—Ball-thrust bearings on both shafts absorb all endwise frictional forces. Easy turning.
- 6—Unique, full floating Steel Nut automatically aligns to axis of lead-screw. Eliminates any possible cause of friction. Easiest of all saw arbors to elevate.
- 7—Two, double seal, life-lubricated ball-bearings of extra large size. Bigger 3/4" diameter shaft (saw bore the same) mounted on larger, heavier duty ball bearings. More costly, but best for 10" blades.
- 8—Tongue and grooved Rear Trunnion completes the rigidity of the "tilt-arbor" mounting.

Boice-Crane's construction, that you see here, fully equals the construction you would expect in machines costing upwards of \$500. Every part, which is subject to even the slightest wear during many years of use, is fully machined, and is made only of long-wearing, accuracy-holding grey cast-iron or steel. No soft, alloy die-castings are good enough here.

So very exacting is Boice-Crane in this regard, that even small parts like our deluxe Rotating Handles on our hand-cranks ARE STEEL—so wear cannot develop even at minor points.

Similar care is given to every part. Consequently, this Boice-Crane Tilting-Arbor Saw is the only power saw which is constructed 100% of cast-iron and steel at all wear-subjected parts . . . and available to you at a remarkably low price.

Thousands of voluntary reports, like those below, have come from enthusiastic users of Boice-Crane's Tilting-Arbor:

... "Five years of use, only 75 cents for repairs" . . . "Three years and still not a penny for upkeep" . . . "Accurate as the day I got it, four and a half years ago."

... "After I wore out a _____ saw in 6 months, I shopped around long and carefully for my second power saw and take it from me I used your 'Magnet Test' for I certainly didn't want any 'die-cast' construction in my second saw. Needless to say, after my magnet test, I bought Boice-Crane. It has proved all you claim, and more. I'll surely get 10 years use out of it."

Testimonials like these attest to the exceptional value in Boice-Crane's rugged construction. When you decide to buy your power saw, be sure to use the informative "Magnet Test" . . . See next page.

AN APPROVED SAFETY GUARD THAT IS *Really Safe!*

Tilts with the blade. Attractive hood shields entire sawblade . . . lifts and drops to table after passage of work. Stiff, hard-tempered steel splitter spreads lumber so pinch never binds. Full range, Anti-Kickback Dogs on both sides of splitter . . . prevent either piece of lumber from being thrown forward . . . and they hold EVERY thickness of stock up to the 3-inch capacity of machine.

Boice-Crane's Steel Splitter is ribbed along both the top and bottom edges for greater stiffness. Our Hood can't even tangle with blade. Our long gentle tapering knife edge enters sawkerf evenly and smoothly, spreads lumber gradually under uniform feed-pressure on part of operator . . . and the very long length of the splitter keeps lumber spread. Worth every penny of its price.

100% SAFE! ANTI-KICKBACK DOGS ON BOTH SIDES OF SPLITTER!

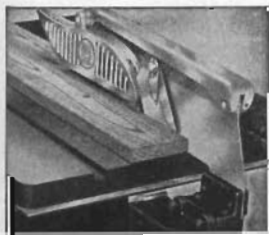
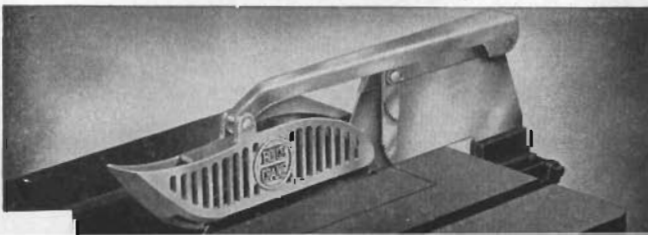

View on right shows the two horizontal "Stop-Screws" which align splitter to blade. Once set always set, to facilitate quick and perfect re-attachment. This guard fulfills all requirements of State Industrial Safety Commission.

No. 2507

Complete Saw Guard for 8- and 10-Inch blades. With hood, and splitter, dogs, cast-iron attaching arm, and attaching screws.
Ship. wt. 24 lbs.

First -- MAKE THIS "MAGNET TEST" BEFORE YOU BUY ANY SAW



On the preceding page, you have read about Boice-Crane's 100% cast-iron and steel construction at every part subject to wear. Most competitive power saws contain part after part made of soft, alloy die-castings—and when these are painted, you nor any buyer can seldom detect by eye the substitution for cast-iron.

This brings up the question, "How then can I distinguish die-cast parts from those of cast-iron or steel, so that I can buy the best built power saw without fail?"

That is just where the "Magnet Test" comes in to help you. Just touch an ordinary horseshoe magnet (every hardware or 10c store has them) to all parts in question. When the magnet "pulls," you know the part is hard-to-wear, cast-iron or steel. When magnet "does not pull," the part is certainly not steel or cast-iron, but is undoubtedly a soft, easy-to-wear, alloy die-casting. Paint does not alter the effectiveness of this test.

Thus, in a few minutes, you can check every part of a number of makes. You find Boice-Crane the outstanding value. In others, you'll find that even their most vitally important parts are usually die-castings even such parts as the trunnions, main-arbor bearing housings, dovetailed slide-ways, worm gears, worm-wheel segments, etc.

Before you buy your power saw, be sure to make this discriminating "Magnet-Test" . . . and you won't go wrong on the power saw you buy. This Boice-Crane Tilting-Arbor Saw is the ONLY 100% cast-iron and steel constructed machine at every wear-subjected part—available at such a remarkably low price. Isn't this the saw YOU want for YOUR shop.

HERE IS THE DRIVE *You Want*

On the floor stand, notice that motor is entirely separate from machine itself. Only Boice-Crane Tilting-Arbor Saws can be driven like that—and the following facts tell why it's most advantageous:

Gives Better Performance. Keeps motor-vibration from reaching saw arbor. No motor weight on trunnions or slide ways. Saves these parts from needless wear. Makes hand cranking easy. Saw arbor stays locked in position. Sawing is always accurate. No. 2511 Motor pulley gives a saw-arbor speed of 4200 r.p.m. for fast and clean cutting with all sizes of blades.

More Versatile. Boice-Crane's Tilting Arbor Saw is the ONLY one which can be successfully driven by motor, gas-engine, or lineshaft.

More Economical. Any "stock" motor of ½, ¾, 1 or 1½ horsepower drives this saw. "Stock" motors are lower in price than "specials." Still another economy for you, which too is ONLY possible with a Boice-Crane Tilting-Arbor Saw, is the saving you can readily make by driving both this SAW and our 6-inch JOINTER by ONE MOTOR.

18-Year Shop Tested. Thousands of installations in eighteen years have thoroughly "shop-tested" Boice Crane's Saw and V-belt drive. We know both are 100% efficient. Our V-belt is much heavier and wider than is used on ordinary saws, and is capable of transmitting up to TWO horse-power. Yet should the saw blade ever become seriously jammed in a cut, V-belts can slip—and many a motor has thus been saved from "burn-out." Our rolling Drive Pulley which makes all these advantages possible, is a practical, proven, efficient transmitter of all the power of your motor.

Boice-Crane's Rolling Drive Pulley acts much like a cone-pulley on a drill press. Only here, the pulley travels rather than the spindle. At "A" is pulley position for 90-degree sawing; at "B" for 45-degree. Pulley travels freely on ball-bearing, splined spindle, and aligns itself automatically to belt. No change occurs in belt tension. No more wear on belt or motor-bearings than occurs with ordinary long length V-belt drives.

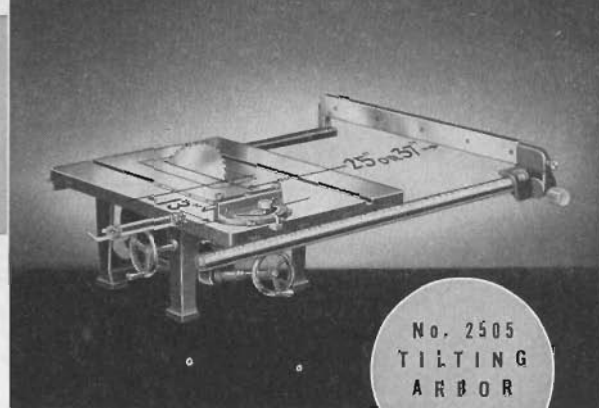
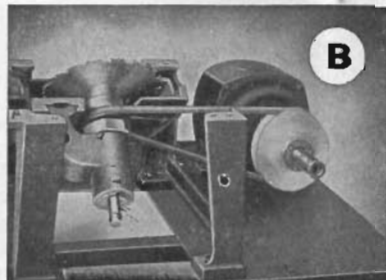
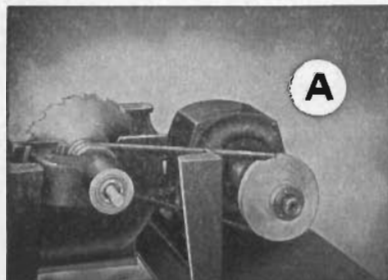

No. 2505
TILTING
ARBOR
SAW

EXTRA WIDE CAPACITY

If you need more than the 21-inch ripping capacity of our standard No. 2500 Tilting-Arbor Saw, you should purchase this Boice-Crane No. 2505 Tilting-Arbor Saw.

With its long extension ripping bars, you can rip a SIX-FOOT wide panel thru the center, at a bevel too if you wish. Ripping capacity is thirty-seven inches when bars are in extended position; twenty-five inches when positioned as shown.

To these bars, table-wings of hardwood are easily attached for a permanent extra large table.

No. 2505 Tilting-Arbor Saw (same in design and equipment as No. 2500 Saw) except that No. 2537 Extra Long Ripping Extension Bars of 37" capacity are furnished instead of standard bars. Ship. wt. 163 lbs.

No. 2537 Extra long Ripping Extension Bars only, when ordered separately for a No. 2500 Saw. No allowance for return of standard bars. Ship. wt. 12 lbs.

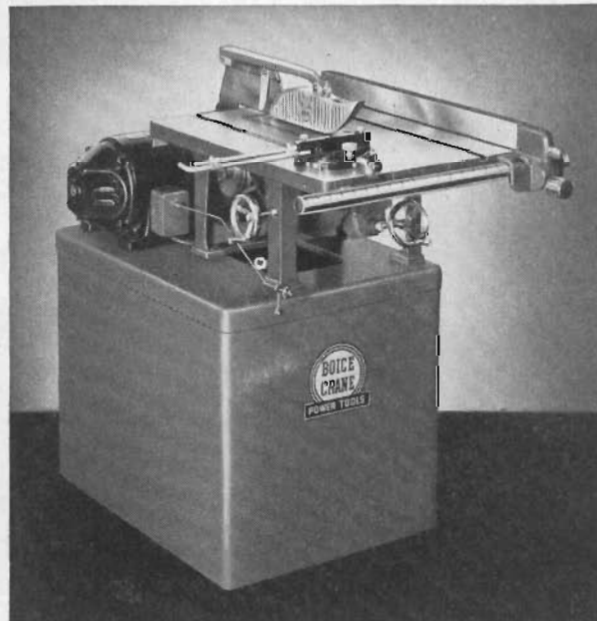

INDIVIDUAL SAW MOTOR DRIVEN FLOOR MODEL

COMPACT — PORTABLE — LOW COST

- No. 2500 Tilting-Arbor Saw with V-belt.
- No. 2511 Rolling Pulley, ¾" hole.
- No. 2585 Motor, 1 h.p., with push-pull switch.
- No. 2541 Cabinet Base, switch rod. Ship. wt. 125 lbs.
- No. 2514 Complete Saw with Stand as itemized above for 110 v. 60 cy., 1 ph. Ship. wt. 390 lbs.
- No. 2510 Belt and Pulley Guard. Ship. wt. 4 lbs.
- No. 2504 Steel, open, leg type stand, switch rod. Ship. wt. 65 lbs.

Other motors on page 41. Recommended for Light Duty, Nos. 2565, 2567, 885; Medium Duty, Nos. 2575, 2577, 887; Heavy Duty, Nos. 2585, 2587, 2595, 2597, 889, 891.

ACCESSORIES FOR SAW TABLES

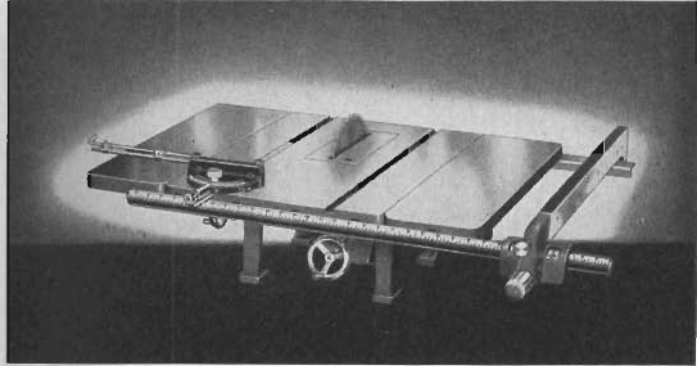
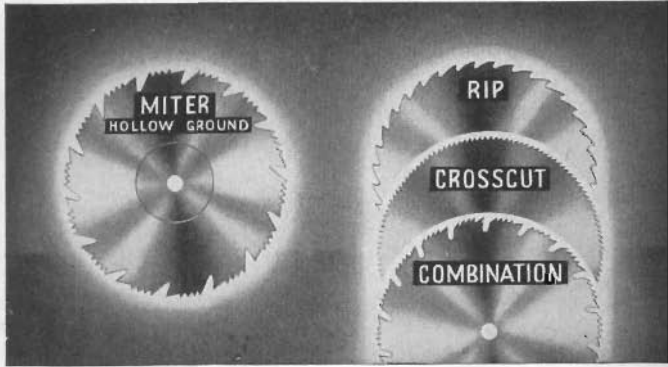

CIRCULAR SAWS FACTORY PRICE • HIGHEST QUALITY

Boice-Crane Circular Saws are distinctly "factory production quality." Made of highest grade steel properly tempered and tensioned. Not to be confused with cheaply made and inferior "homeshop quality" blades.

Standard 3/4" Bore	8" Dia.	10" Dia.
Rip Saws.....	No. 835	1025
Cross-Cut Saws.....	No. 836	1026
Combination Rip and Cross-Cut.....	No. 837	1027
Miter Saws (Hollow Ground).....	No. 838	1028
Ship. wt.....	2 lbs.	3 lbs.

NEW! Table Extension Side Wings

These Side-Wings enlarge the table of Boice-Crane Tilting Arbor Saws to 27½ x 36 inches wide. Enable easier, faster, and more accurate sawing of extra large materials. The side walls of both tables and side-wings are machined to guarantee that entire work-table surface is perfectly smooth just like a single casting.

- No. 2515** Pair of Side Wings for No. 2505 Tilt-Arbor Saws. Ship. wt. 65 lbs.
 Note: When side wings are for No. 2500 Tilting-Arbor Saws, No. 2537 Extension Bars should also be purchased. See page 14.
- No. 2516** Right Table Wing only for Tilt-Arbor Saws installed into No. 2529 Saw-Jointer Units. Ship. wt. 35 lbs.

SANDING DISC—Abrasive on Both Faces

Every woodworker has hundreds of jobs on which to use this low cost Sanding Disc to tremendous advantage. The disc fits on the saw-arbor in place of the circular saw blade, and transforms any Boice-Crane Tilting-Arbor Saw into a most amazingly efficient "Tilting-Disc" sanding machine.

- No. 1733** Sand Disc, 8" dia. 3/4" bore.
- No. 704** Garnet Discs for above. Ship. wt. 1½ lbs. Per dozen.....

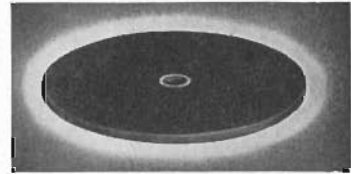

DADO HEADS

Dado Heads are as necessary to the cabinet maker as saw blades themselves. These well made Dado Sets cut grooves and rabbets, with clean sides and bottoms, with or across the grain. They make good strong joints and well fitting tenons, quickly and easily.

The inset view shows that the teeth of Boice-Crane Inside Chipper Cutters are SWAGED WIDER than their bodies... a very important feature.

When these cutters are stacked together to make a wide cut, the cutting teeth OVERLAP each other and cut a clean, and finless groove.

The OVERLAPPING feature also permits you to expand the dado head in width, by inserting a thin shim washer between the cutters, to cut a finless groove even some wider than the standard widths listed below. Excellent for cabinet makers.

- No. 843** Dado Head Sets, 6" dia., 3/4" bore. Cuts widths 1/4", 3/8", 1/2", 5/8", 3/4", 7/8", 1", 1 1/8", 1 1/4", 1 1/2", 1 3/4", 1 7/8", 2", 2 1/4", 2 1/2", 2 3/4", 3", 3 1/4", 3 1/2", 3 3/4", 4", 4 1/4", 4 1/2", 4 3/4", 5", 5 1/4", 5 1/2", 5 3/4", 6". Ship. wt. 2 1/2 lbs.
- No. 844** Dado Head Set. Cuts same as No. 843 plus 7/8", 1", 1 1/8", 1 1/4", 1 1/2", 1 3/4", 1 7/8", 2", 2 1/4", 2 1/2", 2 3/4", 3", 3 1/4", 3 1/2", 3 3/4", 4", 4 1/4", 4 1/2", 4 3/4", 5", 5 1/4", 5 1/2", 5 3/4", 6". Ship. wt. 3 lbs.
- No. 2506** Table Insert for dado and cope heads. Ship. wt. 4 lbs.

COPE HEAD—Side Guarded for Safety

Boice-Crane Cope Heads make beautiful mouldings and enable you to put the touch of a master craftsman on your projects. Boice-Crane Cope Head is easy to set up. Also much safer to use than most others, because it is made of solid, tough steel; each knife is locked by powerful tapered safety wedges and 2 hardened jack-screws; and furthermore, because knives are held against possible side slip by Boice-Crane's Safety Side Plates on both sides of head. Your personal safety is still further increased, because Boice-Crane Knives are high speed steel—not weakened by any holes and are 3/8" inch thick... fully 50% thicker and stronger than usually found in other makes.

Our knives come carefully balanced in sets of three. Patterns listed are widely used, authentic, and in good taste for finest furniture. Cope Head handles any special pattern that can be ground on a 1" wide knife.

- No. 2540** Cope Head, 3/4" bore. No knives. Ship. wt. 3 lbs.
- No. 1541** Formed Knives. Set of three knives of any one
- No. 1547** pattern. Ship. wt. 8 oz.

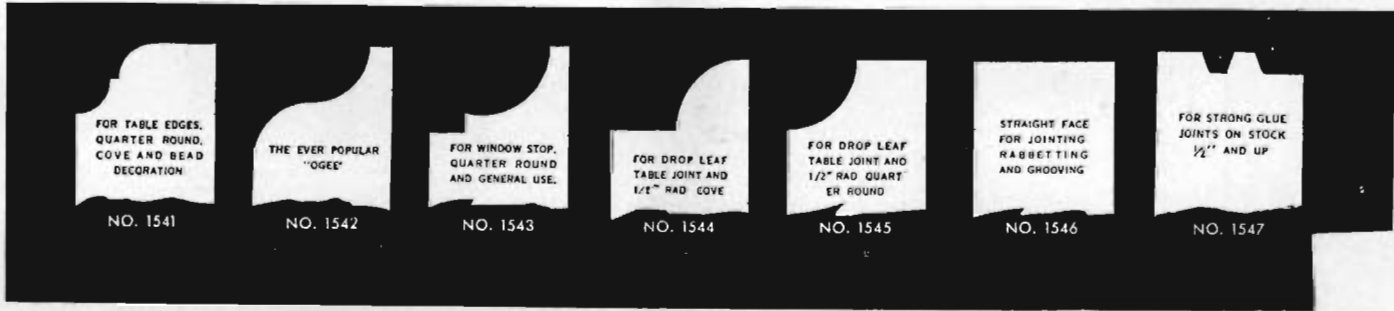
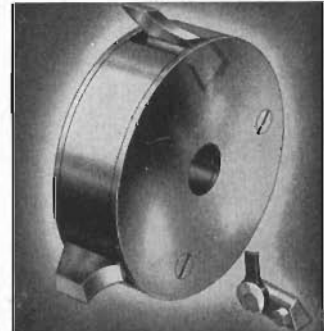

FOR TABLE EDGES, QUARTER ROUND, COVE AND BEAD DECORATION

NO. 1541

THE EVER POPULAR "OGEE"

NO. 1542

FOR WINDOW STOP, QUARTER ROUND AND GENERAL USE.

NO. 1543

FOR DROP LEAF TABLE JOINT AND 1/2" RAD COVE

NO. 1544

FOR DROP LEAF TABLE JOINT AND 1/2" RAD QUARTER ROUND

NO. 1545

STRAIGHT FACE FOR JOINING RABBETTING AND GROOVING

NO. 1546

FOR STRONG GLUE JOINTS ON STOCK 1/2" AND UP

NO. 1547

BOICE-CRANE *Helmet Heads* ...AMERICA'S



No. 2611

ENDORSED BY INDUSTRY

Series 2600 Boice-Crane Drill Presses have a reputation in industry for unusual precision, wider work range and more capacity. These factors have influenced hundreds of leading makers of precision products to choose them for producing instruments, aircraft and ordnance devices.

SPECIFICATIONS

ALL MODELS

Drill to center of circle15" dia.
 Drilling capacity, maximum $\frac{5}{8}$ " in cast iron
 Tapping Capacity, maximum $\frac{1}{2}$ " in brass
 Spindle Travel.....4"
 Chuck, Std. Equipment 0- $\frac{1}{2}$ " Jacobs. $\frac{1}{8}$ " to $\frac{5}{8}$ " Jacobs available at slight extra cost
 Standard Tilting Table10" x 11"
 Production Table, ground area11" x 16"
 Bench Base, ground surface10" x 10"
 Floor Base, ground surface10" x 14"
 Columns, 2 $\frac{3}{4}$ " dia. x $\frac{3}{8}$ " thick wall; centerless ground for extreme accuracy when relocating head or table.

Bearings—4 Life-Grease-Sealed New Departure Bearings. Positive lubrication regardless of head position.

NOTE: All #2 M.T. Spindle Models have two-row ball bearing in bottom spindle position. This heavy duty bearing will handle far greater thrust loads.

1-Spindle Models

	Bench	Floor
Height Overall	42"	71"
Clearance chuck to table ..	10 $\frac{1}{2}$ "	39 $\frac{1}{2}$ "
Clearance chuck to base ...	17 $\frac{1}{2}$ "	46 $\frac{1}{2}$ "

Multiple Spindle Models

Overall Height—bench models 44 $\frac{5}{8}$ ", floor 78 $\frac{5}{8}$ "; work tables—2-spindle, 27" x 23" overall, 24" x 15 $\frac{3}{8}$ " ground surface; 3-spindle, 39" x 23" overall, 36" x 15 $\frac{3}{8}$ " ground surface; 4-spindle, 51" x 23" overall, 48" x 15 $\frac{3}{8}$ " ground surface. Clearance to table—from chuck nose on taper shank spindle type—27", Morse Taper Socket Spindle type—25". Standard Models have columns mounted on 12" centers.

Available on special order—1-spindle machine on 2-spindle work table; 2-spindle on 3-spindle work table with columns on 24" (or closer) centers; or, 3-spindle on a 4-spindle work table with columns on 18" (or closer) centers.

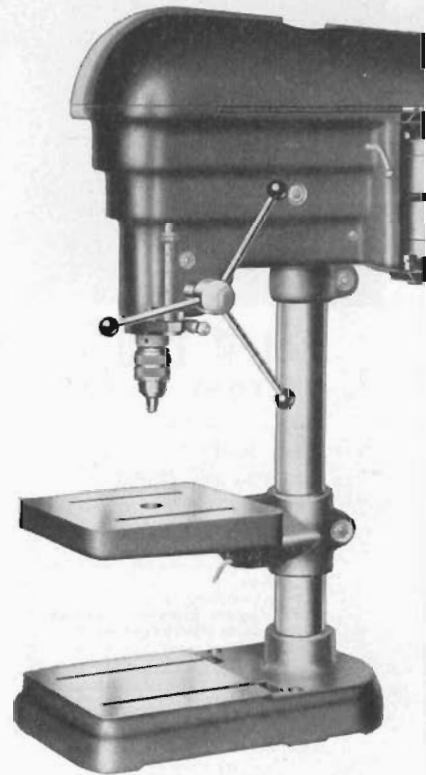

No. 2600

MORE PRECISION HEAVIER DUTY

5 SPEEDS. 25% greater range. An efficient speed for every job. Hinged motor bracket, and easy opening hinged guard makes speed changes easy.

SPLINE DRIVE. A rugged steel drive sleeve carries pulley without imparting belt strain to spindle. Drives spindle by 6 tooth spline. Teeth are new involute type. Sleeve and pulley assembly carried on two extra heavy-duty ball bearings.

OVERSIZE BEARINGS. 2 extra large bearings—30% larger than usually used—take all belt thrust load. Two more sturdy bearings carry the spindle. All are the sealed type—never require lubrication.

OVERSIZE QUILL. 2 $\frac{1}{8}$ " diameter and 20% larger than other 15" presses. Built for larger jobs and longer wearing. Precision ground and micrometer fit to three bearing or quill seats in head.

QUILL SEATS. An exclusive feature! No other press of equal size or price has 4 $\frac{1}{2}$ " of support for the quill, even when drilling 4" deep. Cuts wear from side thrust. Extreme accuracy insured for years.

QUILL FEED. Really sensitive. Extra powerful. Precision fit to quill rack. Pinion is copper brazed to shaft.

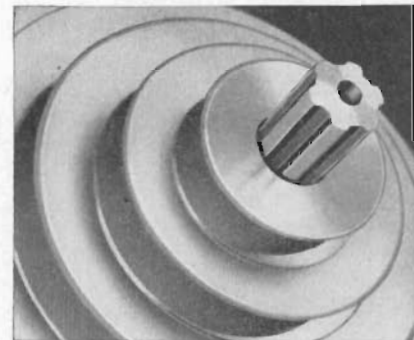

A modern, finely engineered 6-tooth spline drive. The first application of the new, eminently successful involute type spline tooth to a drill press in the low price field. Transmits all the power to the spindle with noticeably less vibration, especially on heavy jobs.

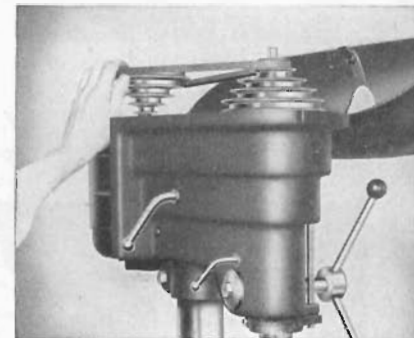

This super-safe drive guard is standard equipment on every model. Side hinged. Easy and quick access to drive when spindle speed needs changing. To change speeds on a Boice-Crane, operator never needs to leave his post at the front of the machine.

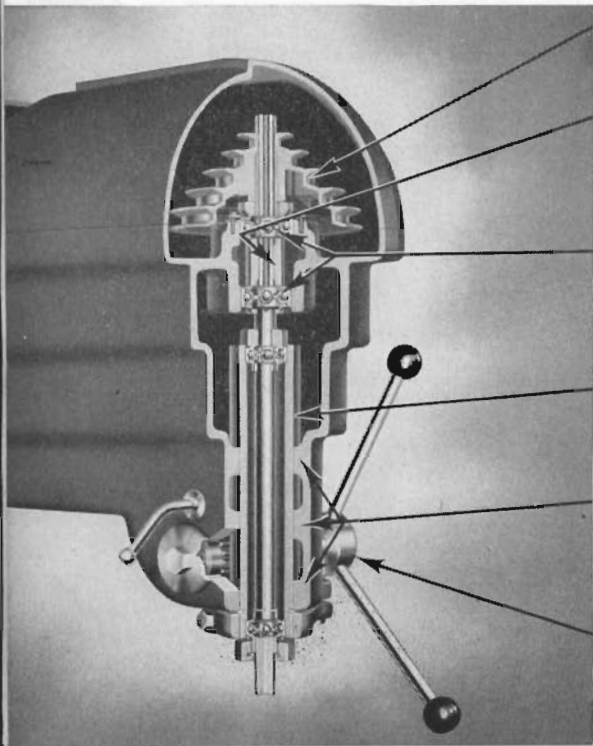

FINEST MEDIUM-PRICED DRILL PRESSES •

Other

PRECISION AND DESIGN FEATURES

WORK TABLES Exceptionally smooth and accurate . . . flat to a tolerance of $\pm .000$ "— $.005$ " maximum. Single and two-spindle tables ground, all others planed. All types strongly cross-ribbed and treated against warping. A high quality feature!

COLUMNS $\frac{3}{16}$ " thick wall, seamless, precision centerless ground steel columns. Separate flange method of mounting columns to bases on most models, permits close degree of guaranteed precision alignment between spindle nose and table.

LINE BORED HEAD Head design and head bore tooling is such that all seats for quill and upper bearings are roughed and finished in one continuous operation working from one end, guaranteeing perfect spindle alignment. Stopped against that bore, the column bore is made, again producing perfect alignment between spindle, quill, and column.

SPEED RANGES High and slow speed ranges both have 5 selective speeds to permit a wide range of efficient setups. Speed ranges using 1750 r.p.m. motors: High Speed Series—500 to 5500 in 5 steps; Slow Speed Series—425 to 3340 also in 5 steps. No. 2607 Attachment (see page 21) produces speeds as low as 150 r.p.m.'s.

VERSATILE Recommended for tooling that calls for closer precision and "around-the-clock" operating conditions, as in aircraft magneto and instrument manufacture. Ideal for toolroom, jig and fixture work and all-around general purpose drilling and tapping. Clean head design and sealed-for-life bearings (lubrication in any position) make them a strong favorite with designers of special purpose machinery, aircraft wing jigs, etc.

ATTACHMENTS See page 21 for special attachments that greatly enlarge your Boice-Crane Drill Press capacity and reduce production time. Practical accessories for Tapping, Mortising, Shaping, Sanding. Air Operated Automatic Feed, Radial Arm for increasing spindle reach.

PROMPT STOCK MODEL SHIPMENTS



Every model listed on page 20 is a standard model produced in large quantities. Consequently dealers are delivering orders from local stock in most cases, otherwise by prompt factory shipment.

Boice-Crane has a large, modern plant equipped with up-to-date precision machine tools. Our efficient facilities, devoted entirely to building light industrial machinery is your guarantee of high quality at really moderate prices and delivery to suit your schedule.

MODELS for SPECIAL REQUIREMENTS

While all listed models are highly standardized, the individual parts such as the various heads, columns and work tables can be combined in numberless ways to produce economically priced special types for specific needs.

For instance, on special order we can furnish single spindle machines on 24", 36", and 48" long manufacturing type work tables; or, 3 spindle machines on 48" work tables.

Also, columns can be variously located. See page 21 for dimension data.

Weeks of time and dollars by the thousands saved for over-burdened plants by smart tool designers incorporating these "easy-to-build-in" heads into special purpose machines or aircraft production jigs.

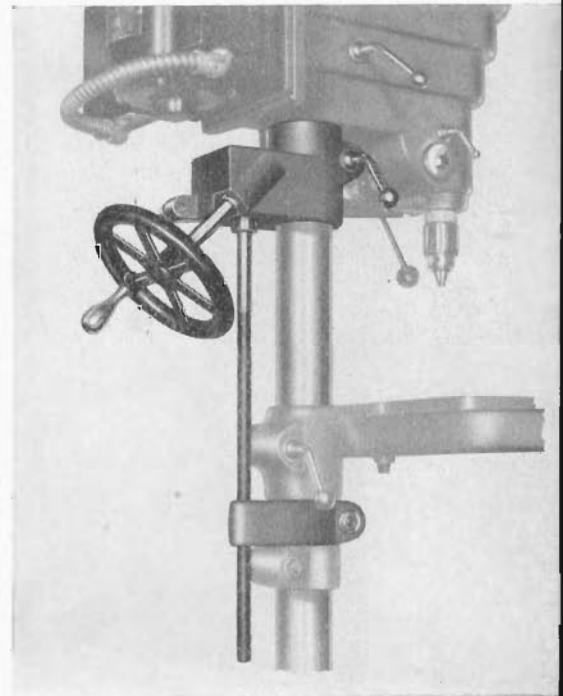

Feature Accessory

HEAD AND TABLE RAISER

Any single or multiple spindle bench or floor model can be equipped with the No. 2624 Raising Attachment at the factory or later. Fits any make using $2\frac{3}{4}$ " dia. column.

On 1-spindle floor models raises the table as well as the head. Equipped with steel spiral gears, ball thrust bearings on shafts.

SERIES 2600

Helmet Heads



No. 2610



No. 2652



No. 2616

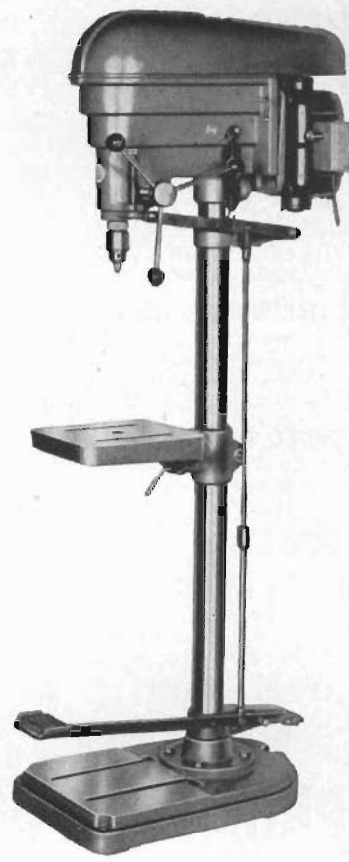

No. 2673

All Single Spindle Models Available with Two Types of Work Tables

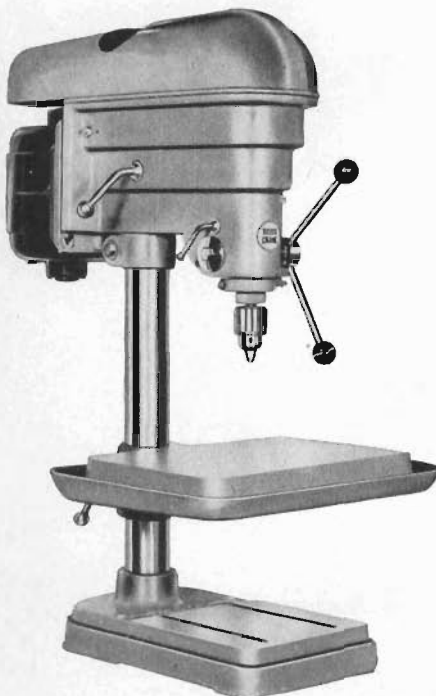

No. 2601

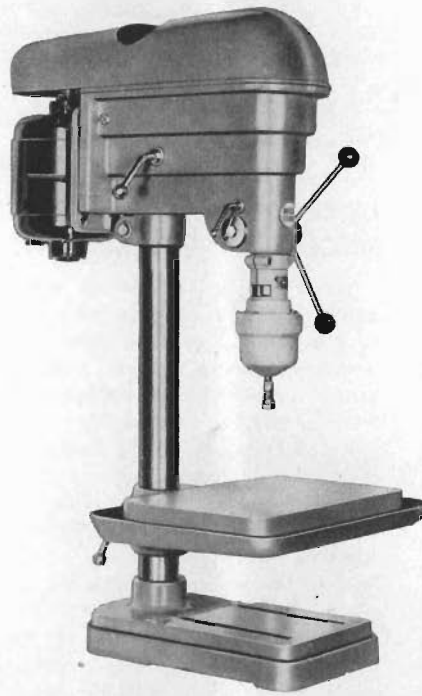

No. 2628

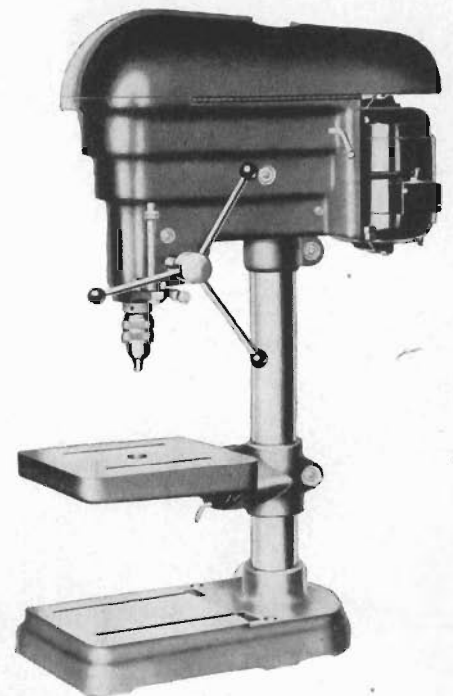

No. 2600

High and Slo-Speed Models—No. 33 Chuck Taper, or No. 2 M. T. Socket Spindles

FOR EVERY TOOLING NEED •

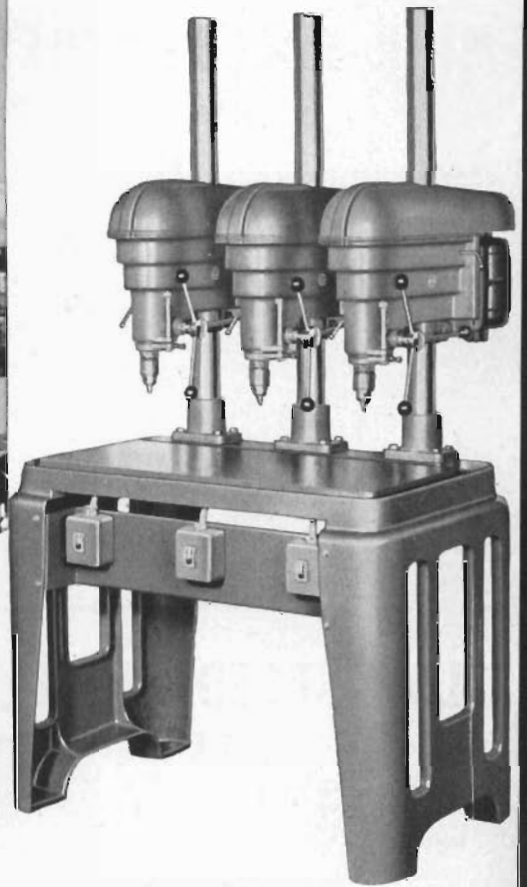

No. 2638

Truly one of industry's greatest production aids, delivering more production per dollar of cost than was ever dreamed possible a few years ago. Amazing precision for the price!



No. 2669

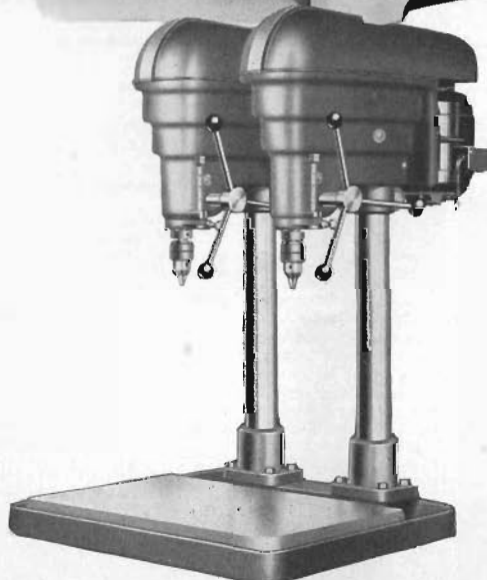

No. 2620



No. 2640

Manufacturing Types—1, 2, 3 and 4 Spindles—Bench or Floor Models

"2600 SERIES" 5/8" CAPACITY DRILL PRESSES

HIGH-SPEED MODELS

Speeds—500, 925, 1750, 3250, 5500 R.P.M. using 1750 R.P.M. Motor

BENCH TYPE

FLOOR TYPE

Cat. No.	Type of Spindle	Description	Ship. Wt.	Price	Cat. No.	Type of Spindle	Description	Ship. Wt.	Price
2600	Chuck	Std. Tilt Table	185 lbs.		2610	Chuck	Std. Tilt Table	205 lbs.	
2646	No. 2 Morse	Std. Tilt Table	185 lbs.		2673	Chuck	Std. Tilt Table and #2608 Foot Feed	226 lbs.	
					2650	No. 2 Morse	Std. Tilt Table	205 lbs.	
					2681	No. 2 Morse	Std. Tilt Table and #2608 Foot Feed	226 lbs.	
2601	Chuck	Production Table	207 lbs.		2611	Chuck	Production Table	227 lbs.	
2648	No. 2 Morse	Production Table	207 lbs.		2685	Chuck	Prod. Table and #2608 Foot Feed	248 lbs.	
					2652	No. 2 Morse	Production Table	227 lbs.	
					2693	No. 2 Morse	Prod. Table and #2608 Foot Feed	248 lbs.	
2666	Chuck	1-spindle Manufacturing Type with	296 lbs.		2697	Chuck	1-spindle Manufacturing Type with	584 lbs.	
2669	No. 2 Morse	27" x 23" Work Table	296 lbs.		2699	No. 2 Morse	27" x 23" Work Table and #2602 Cast Iron Legs	584 lbs.	
Cat. No.	No. of Spindles	Type of Spindles	Ship. Wt.	Price	Cat. No.	No. of Spindles	Type of Spindles	Ship. Wt.	Price
2620	2	No. 33 Chuck Taper	390 lbs.		2682	2	No. 33 Chuck Taper	678 lbs.	
2622	2	No. 2 Morse Taper	390 lbs.		2684	2	No. 2 Morse Taper	678 lbs.	
2629	3	No. 33 Chuck Taper	612 lbs.		2638	3	No. 33 Chuck Taper } Floor Legs	885 lbs.	
2634	3	No. 2 Morse Taper	612 lbs.		2644	3	No. 2 Morse Taper } Only	885 lbs.	
2640	4	No. 33 Chuck Taper	750 lbs.		2690	4	No. 33 Chuck Taper	1000 lbs.	
2642	4	No. 2 Morse Taper	750 lbs.		2692	4	No. 2 Morse Taper	1000 lbs.	

SLOW-SPEED MODELS

Speeds—425, 775, 1330, 2200, 3340 R.P.M. using 1750 R.P.M. Motors

BENCH TYPE

FLOOR TYPE

Cat. No.	Type of Spindle	Description	Ship. Wt.	Price	Cat. No.	Type of Spindle	Description	Ship. Wt.	Price
2630	Chuck	Std. Tilt Table	187 lbs.		2674	Chuck	Std. Tilt Table	207 lbs.	
2632	No. 2 Morse	Std. Tilt Table	187 lbs.		2673	Chuck	Std. Tilt Table and #2608 Foot Feed	228 lbs.	
					2676	No. 2 Morse	Std. Tilt Table	207 lbs.	
					2681	No. 2 Morse	Std. Tilt Table and #2608 Foot Feed	228 lbs.	
2635	Chuck	Production Table	209 lbs.		2678	Chuck	Production Table	229 lbs.	
2637	No. 2 Morse	Production Table	209 lbs.		2685	Chuck	Prod. Table and #2608 Foot Feed	250 lbs.	
					2680	No. 2 Morse	Production Table	229 lbs.	
					2693	No. 2 Morse	Prod. Table and #2608 Foot Feed	250 lbs.	
S2666	Chuck	1-spindle Manufacturing Type with	298 lbs.		S2697	Chuck	1-spindle Manufacturing Type with	586 lbs.	
S2669	No. 2 Morse	27" x 23" Work Table	298 lbs.		S2699	No. 2 Morse	27" x 23" Work Table and #2602 Cast Floor Legs	586 lbs.	
Cat. No.	No. of Spindles	Type of Spindles	Ship. Wt.	Price	Cat. No.	No. of Spindles	Type of Spindles	Ship. Wt.	Price
2658	2	No. 33 Chuck Taper	394 lbs.		2686	2	No. 33 Chuck Taper	534 lbs.	
2660	2	No. 2 Morse Taper	394 lbs.		2688	2	No. 2 Morse Taper	534 lbs.	
2653	3	No. 33 Chuck Taper	618 lbs.		2662	3	No. 33 Chuck Taper } Floor Legs	891 lbs.	
2661	3	No. 2 Morse Taper	618 lbs.		2664	3	No. 2 Morse Taper } Only	891 lbs.	
2670	4	No. 33 Chuck Taper	758 lbs.		2694	4	No. 33 Chuck Taper	1008 lbs.	
2672	4	No. 2 Morse Taper	758 lbs.		2696	4	No. 2 Morse Taper	1008 lbs.	

SPECIAL NOTES

Standard Equipment: O-1/2" cap. Jacobs Chuck and key where indicated above; V-belt; Motor Pulley—either 1/2" or 5/8" bore; motor bracket but no motor.

1/8"—5/8" cap. Etco Keyless Chuck substituted for standard O-1/2" Chuck—\$9.25 each extra.

Cast iron floor legs in place of cabinet stand—deduct \$38.00 on 2-spindle or \$60.00 on 4-spindle floor models. Legs are standard on all 3-spindle models.

No. 2624 Head Raiser attachment can be added to any of the above models. See page 17.

See page 21 for list of woodworking attachments.

ACCESSORIES

- No. 115 Machine Light, Adjustable. Uses Std. bulb. Sh. Wt. 1 lb.
- No. 2607 Slo-speed Attachment. See page 21.
- No. 2609 Arbor for chuck. No. 2 M.T. shank. 1 lb.
- No. 2619 Chuck, Jacobs 1/8"—5/8" cap. with key. Shipping weight 5 lbs.
- No. 2643 Chuck, Jacobs O-1/2" cap. with key. Shipping weight 3 lbs.
- No. 2623 Remote Control Rod for motor switch. For 1-phase motors only. Install on single and multiple spindle models. Practical. Very handy. Shipping Wt. 1 lb.
- No. 2624 Head & Table Raiser Attachment. Complete for 2 3/4" columns. Ship. wt. 25 lbs.
- No. 2625 Production Table. Working surface 11" x 16". Coolant trough tapped for pipe. Ship. wt. 65 lbs.

MOTOR CONTROLS

- No. 899 3-pole Manual Starter only. Not installed. Ship. wt. 10 lbs.
- No. 899A Same as above but includes bracket, wiring material and complete installation. Ship. wt. 15 lbs.
- No. 895 Manual Overload Protection Starter, includes bracket, wiring material and complete installation. Ship. wt. 15 lbs.
- No. 896 Magnetic Overload Protection Starter, includes bracket, wiring material and complete installation. Ship. wt. 15 lbs.
- No. 897 Same as No. 896 except includes remote control push-button station mounted handy to operator

MOTORS

No.	H.P.	Phase	Voltage	Bearings	Ship. Wt. Lbs.	Price
*885	1/2	3	220	Ball	32	
*885A	1/2	3	440	Ball	32	
*887	3/4	3	220	Ball	55	
*887A	3/4	3	440	Ball	55	
‡2655	1/3	1	110	Ball	34	
‡2657	1/3	1	220	Ball	34	
‡2665	1/2	1	110	Ball	62	
‡2667	1/2	1	220	Ball	62	
‡D2575	3/4	1	110	Ball	62	
‡DA2575	3/4	1	220	Ball	62	

* No switch, cord or plug.

‡ Repulsion-Induction motors. Include 2 pole switch suitable for remote control rod. Includes cord and plug.

Helmet Heads ATTACHMENTS and ACCESSORIES

Helmet Heads Quickly Become Efficient Tappers

Convert Boice-Crane Helmet Heads into high speed industrial tappers in just a few minutes. Inexpensive. Rigid mounting reduces tap breakage. Precision built. Extremely sensitive. Ball bearing construction adds accuracy, longer life. Carefully balanced reversing mechanism instantly reverses at double the "in" speed. Long life clutch facings, protected so that oil can't reach clutch surface. Spindle always idles in "forward" position to save clutch and gear wear.

Patented True Grip tap holding collets give positive driving power, lengthen tap life tremendously.

TAPPING ATTACHMENTS

- No. 2603** Tapping Head for No. 2600 series Drill Press. Capacity No. 2 to 1/4" in brass and cast iron, No. 2 to 3/8" in steel, with collets for Nos. 2, 3, 4, 5, 6, 7, 8, 9, 10 and 1/4" taps; wrenches and driving dog. Ship. wt. 6 lbs.
- No. 2604** Tapping Head for No. 2600 series Drill Press. Capacity No. 8 to 1/2" in brass, No. 8 to 3/8" in cast iron, No. 8 to 3/8" in steel; collets for Nos. 8, 9, 10, 1/4", 3/8", 5/8", 3/4" and 1/2" taps; wrenches; driving dog. Ship. wt. 10 lbs.

COMPLETE TAPPING MACHINES

- No. 2615** Floor type with 2678 Drill Press with production table, No. 2603 Tapper 1/4" capacity, No. 2608 Foot Feed attachment, no motor included. Ship. wt. 265 lbs.
- No. 2616** Same but has No. 2604—1/2" Tapper. Ship. wt. 269 lbs.
- No. 2627** Bench Type with No. 2635 Drill Press with production table, No. 2603 Tapper 1/4" capacity, no motor or foot feed included. Ship. wt. 223 lbs.
- No. 2628** Same but has No. 2604 1/2" Tapper. Ship. wt. 227 lbs.



No. 2608 Foot-Feed Attachment—As shown, complete, ready to attach. Ship. wt. 25 lbs.

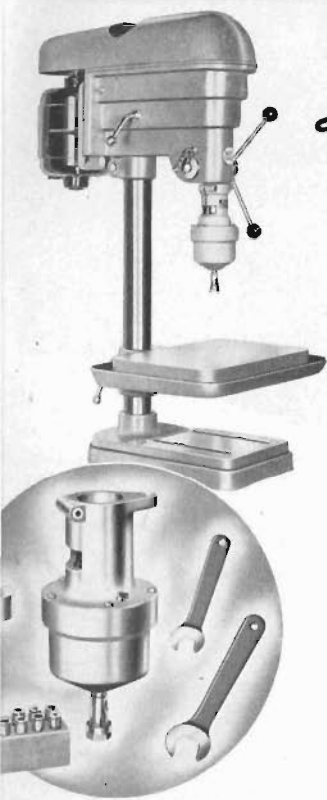

No. 2604 Tapping Attachment

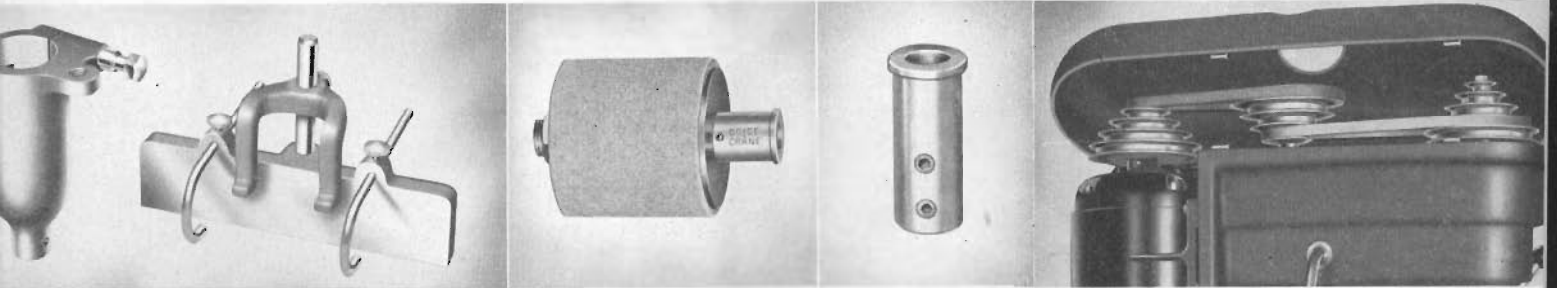

No. 2612 Mortiser Attachment mortises as rapidly and accurately as individual mortising machines of twice the price. Strong chisel holder and complete vice with work hold-in rods, hold-down shoe and all bits included in the price. Ship. wt. 9 lbs. Chisels and bit are extra. Listed on page 40.

No. 2605 Sand Drum quickly smooths sawed edges to satin finish. Complete as shown with 3" x 3" rubber Drum, washers and one abrasive sleeve. (2" drum, extra abrasive sleeves listed page 33.) Ship. wt. 3 lbs.

No. 2613 Multi-Purpose Spindle Extension takes 1/2" diameter shanked Router bits and Plug Cutters, etc. and many other 1/2" shank special tools. Ship. wt. 8 oz.

SLO-SPEED ATTACHMENT. Add to your range of drilling speeds. The low limit of 150 rpm's will permit drilling with 1/2" carbon steel drills successfully. Helmet Head fully encloses this attachment.

No. 2607 Slo-Speed Attachment including 2 belts and idler pulley. Ship wt. 5 lbs.

Heads and Parts for Special Setups

Helmet Heads easily handle 4 and even 6 spindle multiple heads. If interested in multiple drilling or tapping please write us.

We are prepared to assist tool designers and special machinery builders in incorporating standard drill press parts into their products. Letters requesting special engineering data always answered promptly.

Manufacturing type work tables furnished in the three sizes shown here. All have oil trough tapped for connecting coolant systems. We show normal column locations, but tables are provided with additional bosses every 6" to meet special engineering needs.

- No. 2617** Helmet Head only, high speed type, with belt, motor pulley, feed pilot wheel, motor bracket. Specify chuck, No. 2 Morse Taper. Ship. wt. 80 lbs.
- No. 2618** Same except slo-speed type. Ship. wt. 81 lbs.
- No. T-2672** Column Collar complete. Ship. wt. 3 lbs.
Note: 3 needed on radial drill shown at right.
- No. B-2674** Base Flange Casting. Ship. wt. 10 lbs.
- No. B-2643** Ground, Tubular Steel, bench length column. Ship. wt. 20 lbs.
- No. R-2600** Radial Arm. See illustration at right. Ship. wt. 35 lbs.
- No. R-2601** 12" long Stub Column for Radial Drill. See illustration. Ship. wt. 45 lbs.
- No. T-2602** Work Table, 27" x 23". Ship. wt. 167 lbs.
- No. T-2603** Work Table, 39" x 23". Ship. wt. 279 lbs.
- No. T-2604** Work Table, 51" x 23". Ship. wt. 395 lbs.
- No. 2602** Cast Floor Legs. Ship. wt. 250 lbs. per pr.

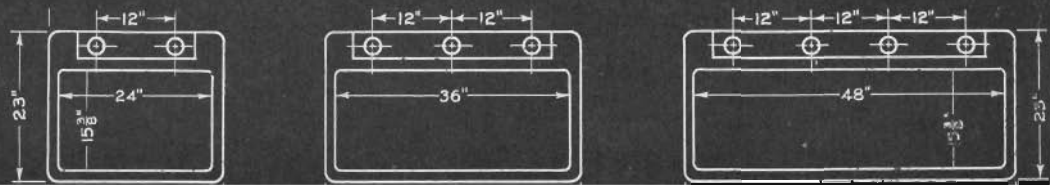
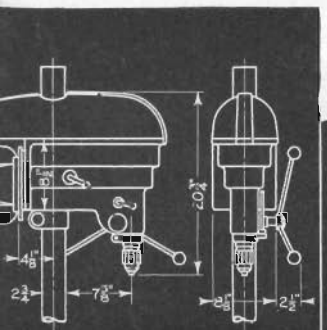
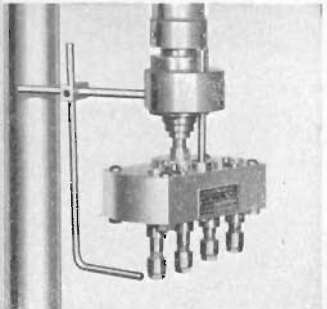

Boice Crane

FRICITION - MATIC *America's Finest* WET TOOL AND KNIFE GRINDER



6 popular models (all prices f.o.b. Toledo, Ohio)

- | | |
|--------------------|----------------|
| for • School shops | • Fixit shops |
| • Craftsmen | • Carpenters |
| • Butchers | • Mechanics |
| • Hotels | • Meat packers |
| • Farms | • Restaurants |
| • Parks | • Plantations |
| • Road work | • Cemeteries |

The modern grinder for hand tools, carving and carpenter tools, knives, scissors, scythes, sickles, machetes, garden tools, etc.

SELF-ADJUSTING FRICTION ROLL DRIVE

(Pat. Pend.) Simple. Compact. Powerful. 1/4 H.P. drives it, yet practically impossible to stall.

CONSTANT SPEED

As wheel wears, it automatically runs faster, thus maintaining a constant peripheral speed of approximately 280 surface feet per minute. No other wet grinder has this feature.

NO WATER THROWN ON OPERATOR

Powerful friction drive, by rubber roller, gives a controlled water action which obsoletes grinders that throw water. The Friction-matic leaves just enough water on the wheel for super-keen edge grinding.



Portable bench MODEL 205. Ideal for carpenters, contractors, butchers, farmers. Consisting of No. 200, No. 207-1 heavy gauge welded steel bench base No. 1026 V-belt. Ship. wt. 10 oz.
No. 1012 V-pulley, 1/2" bore. Ship. wt. 8 oz.
Ship. wt. 27 lbs.

No. 208 1/4 H.P. 1750 r.p.m., 110-V., 60 cy., 1-ph., A.C., 1/2" shaft motor. Ship. wt. 20 lbs.

PERMITS PROPER PRESSURE CONTROL

Since no waterguard is necessary, the tool rest can be positioned so that the operator takes a comfortable standing position to work on top of the wheel and so perfectly control pressure of the tool against the wheel.

NEW TYPE 100% WIDER TOOL REST (2 1/2" x 5")

Large enough for long, slim carving and slicing knives, the wide blade of long-handled axes and hatchets, and the widest plane bits and scrapers.

ACCURATE CONTROLS FOR GRINDING ANGLES FROM ZERO TO 30°

The first wet grinder with adequate adjustment to the tool rest. Has adjustment compensating for wheel wear.

SPECIFICATIONS

STONE: Natural quarried Ohio sandstone wheel. 8" dia., 1 1/2" face. Carefully trued. Cemented to shaft by special process.

MAIN SHAFT: 1/2" dia. Stainless steel.

DRIVE: 1" x 2" long wearing rubber friction wheel molded on shaft. Friction drive carrier spring loaded to maintain powerful drive at all times.

FRAME: Tank, cover, main frame and tool rest 16 gauge steel. Gray enameled inside and out to resist rust. Water drain-off provided.

No. 201 Wheel Dressing Stick, Aloxite, 6" x 1" x 1". Ship. Wt. 1 lb.

Dual MODEL 212. Ideal for schools, "fixit," and custom grinding shops, meat packing plants, and wherever tools and knives are given a razor-like edge. Consisting of No. 200 with coarse stone, No. 202 with very fine Arkansas stone
No. 214-1 bench base
2 No. 1025 V-belts
2 No. 1012 V-pulleys, 1/2" bore

No. 215 1/3 H.P., 110V., 60 cy., 1-ph., A.C. motor with double end shafts
Ship. wt. 90 lbs.

MODEL 213. Same as No. 212 except with No. 214 steel floor stand. Ship. wt. 100 lbs.



Hand operated bench MODEL 211. Easy operating. Ideal for farm, plantation, park, cemetery, road work, and wherever no power is available. Large flywheel type crank with free rotating handle. When desired, motor replaces hand drive on same bench. Ship. wt. 65 lbs.

Bench MODEL 200 for those who already have a suitable 1/4 or 1/2 H.P. motor. Has four holes for quickly mounting to bench. Ship. wt. 17 lbs.

No. 1012 Motor Pulley, 2" dia., 1/2" bore, for 1/4" h.p. motor. Ship. Wt. 8 oz.

No. 1030 V-Belt. Ship. Wt. 10 oz.

No. 208 1/4 H.P. 1750 r.p.m., 110-V., 60 cy., 1-ph., A.C., 1/2" shaft motor. Ship. wt. 20 lbs.



MODEL 206 (as above) consisting of:

No. 200 Wet Grindstone

No. 207 Floor stand

No. 1026 V-belt. Ship. wt. 10 oz.

No. 1012 V-pulley, 1/2" bore. Ship. wt. 8 oz.
Ship. wt. 38 lbs.

No. 208 1/4 H.P. 1750 r.p.m., 110-V., 60 cy., 1-ph. A.C., 1/2" shaft motor. Ship. wt. 20 lbs.

Boice Crane

14-INCH BAND SAW

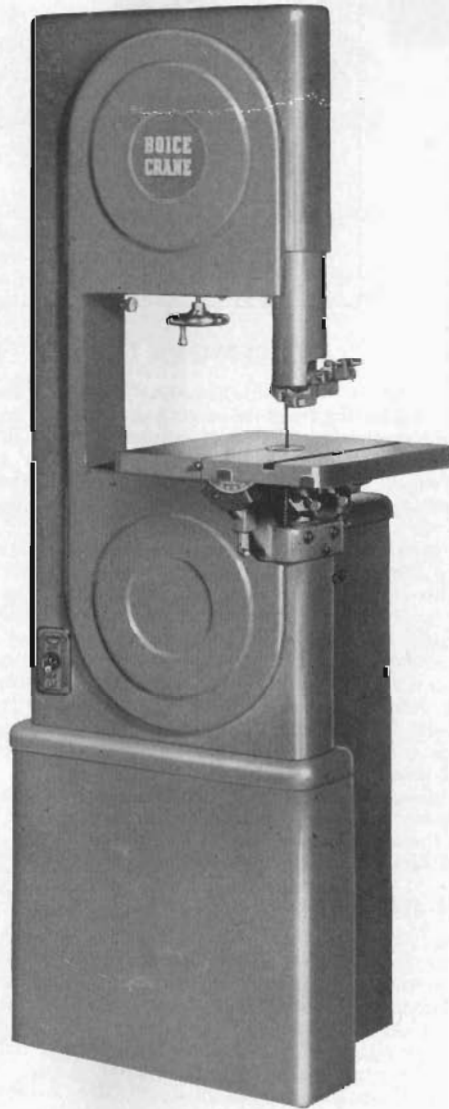

BOICE-CRANE POWER TOOLS

CUTTING • SHAPING • DRILLING • FINISHING
WOOD METAL FIBRE PLASTICS
IN INDUSTRY • SCHOOLS • HOME SHOPS

BOICE - CRANE COMPANY
930 W. CENTRAL • TOLEDO 6, OHIO

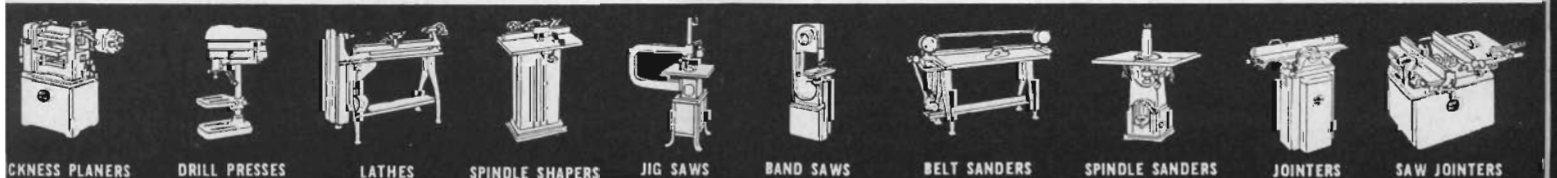

THICKNESS PLANERS

DRILL PRESSES

LATHES

SPINDLE SHAPERS

JIG SAWS

BAND SAWS

BELT SANDERS

SPINDLE SANDERS

JOINTERS

SAW JOINTERS

Boice Crane

14-INCH BAND SAW

SPECIFICATIONS

SAWING CAPACITY: Blade to guard	13½"
Guide to Work Table	7¾"
TABLE: Tilts on Double-Trunnions 45° to right; 10° to left; size	15" x 15½"
HEIGHT OVERALL of Floor Model	67"
HEIGHT OF WORK-TABLE from Floor	39¼"
OVERALL WIDTH 27½"	Overall depth 29"
BLADE WIDTHS: ⅜", ¼", ⅜", ½" and ¾"	
LENGTH OF BLADE	98"
WHEELS: Disc, Moulded Textolite. 14" dia. 1" face.	
BEARINGS: Grease-sealed Ball Bearings.	
FRAME: Heavy Welded-Steel Construction.	
OPERATING SPEEDS:	
1-Speed Model Wheel r.p.m.'s	1120
Blade Feet Per Min.	4100
8-Speed Model Wheel r.p.m.'s	1120 890 660 450 70 50 35 25
Blade Feet Per Min.	4100 3260 2120 1650 250 183 128 92
Net Wts. (less motor)	No. 2300 122 lbs. No. 2301 224 lbs. No. 2304 155 lbs. No. 2308 250 lbs. No. 2309 352 lbs. No. 2310 257 lbs.
Gross Wts. (less motor)	No. 2300 197 lbs. No. 2301 334 lbs. No. 2304 230 lbs. No. 2308 320 lbs. No. 2309 427 lbs. No. 2310 367 lbs.

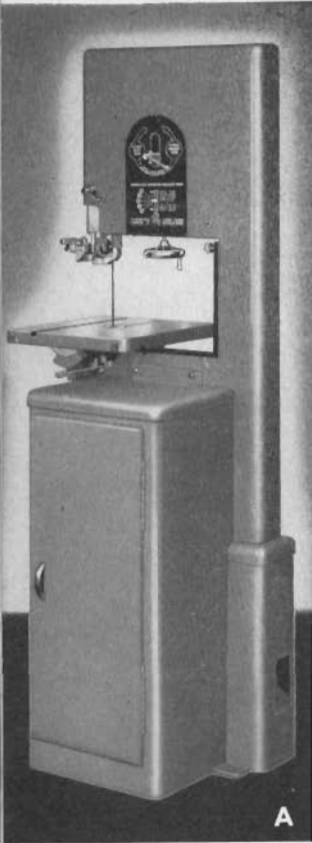

A

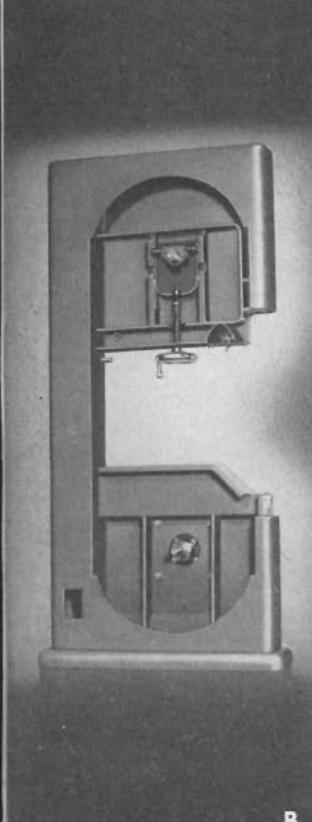

B

STRONGER STEEL FRAME—FASTER—SAFER

Steel-clad design makes this the safest 14" band saw built. Given top rating by State Safety Commissions, it is the best medium size band saw for industry, schools, and homeshops. The unretouched photo (E) shows how its high speed super sawing smoothness saves sanding labor on every cut, again saving important money on all fine work.

Actual tests prove that a Boice-Crane Band Saw saws from *two to four times* more lumber footage in a given time than any other 14-inch Band saw built and averages *three times faster* to make for tremendous savings in time, labor and money. If you use a band saw 3 hours a day a Boice-Crane saves you at least \$300 a year, paying for itself in 3 to 6 months. Fully 80% of all your band-sawing is done with feed pressures of 4, 6, or 8 pounds . . . so you can use it most where the Boice-Crane effects the very greatest increase in output, and where it produces the greatest profit. See chart at top of next page.

All mechanisms, motor, etc., are fully enclosed. No ugly cross-arms, or exposed moving parts.

Notice the blade tension scale (A)—calibrated for all widths, and easy-to-use blade tracking scale.

HIGH SPEED ZEPHYR-WEIGHT WHEELS

The Boice-Crane has solid TEXTOLITE disc-wheels. Made of one of the strongest yet lightest weight plastic materials known, moulded in a scientifically proportioned section of maximum strength per unit of material. Each wheel weighs only 2½ pounds, permitting operation at near twice normal speed yet assuring years longer ball-bearing life. Even at 1200 r.p.m. wheel speed, the resulting blade-strain on Boice-Crane blades is 20% to 40% LESS than other 14" machines which normally operate at 600 r.p.m.

The entire framework is electric-welded into a single, vibrationless, one-piece steel structure of terrific strength and stiffness. The smooth interior is easy to keep clean and sanitary when used to cut food products. The steel bulkhead at back of lower wheel-compartment protects motor from all dust, and grime. (Illustration B).

The wheel-guard is a single, hinged door, part of the machine, and must be closed before operating.

The blade is guarded on all sides by a heavy steel telescoping guard. Conventional machines leave the rear of the blade and fully half the outer side of blade entirely unguarded, another Boice-Crane "first."

The Telescoping Guard is held friction-tight in its ways by a compression spring. When lock handle is released the guard does not drop, but stays in place until operator repositions it. It even covers and shields the upper blade-guide from accidental damage.

NEW—IMPROVED BLADE GUIDES

A new, patented type of upper and lower blade guides is standard on the Boice-Crane. One handy control knob (not the usual two) provides faster, micrometer-like setting for both the side jaws and ball bearing back-up roller. (See illustration C).

Blade guide adjustment controls are also brought out to the rear, so adjustments can be made *safely, with the machine actually running*, and also without the aid of any kind of special wrenches, or screwdriver.

The only guide with all these features:

1. One-knob setting control
2. Independent micro-adjustment
3. Anti-creep locks
4. Large back-up roller (sealed ball-bearing type).

The generous size work table, 15" x 15½", is rigidly supported on two large trunnions, one at front, another at rear. (See illustration D). No sag or vibration under heavy cuts. The blade-entry-slot leads to front (not the side) of table . . . the only correct location for quick and easy blade installation. Table tilts 45 degrees to right, 10 to left. Has 90° locating stop, also accurate table-tilt gauge. Removable throat-piece is keyed so sides cannot strike blade.

Large steel cabinet-stand provides a solid rock-like foundation—adding to the smooth performance of the Boice-Crane. Also furnishes a sealed-off, dust free compartment for motor, as well as extra blade storage.

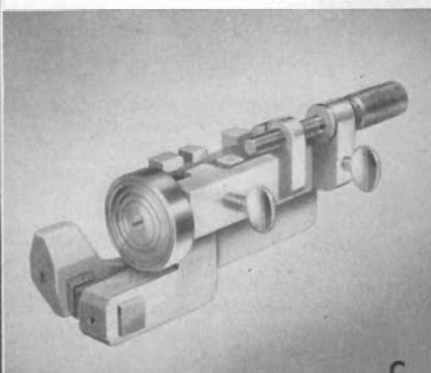

C

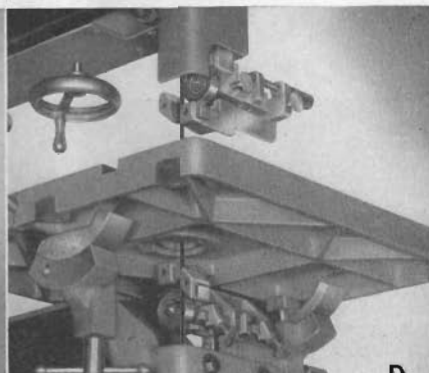

D

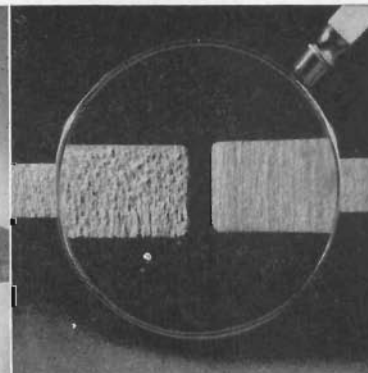

E

CUTS WOOD 2 TO 4 TIMES FASTER

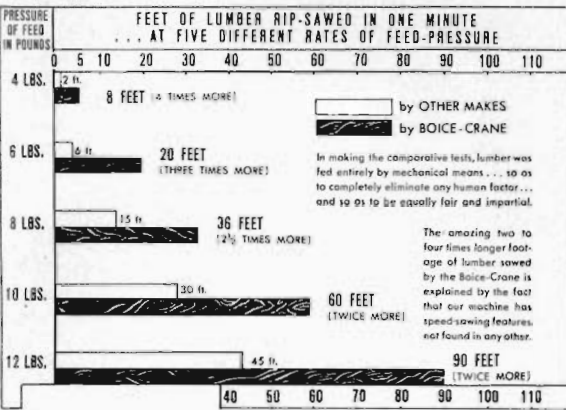

Actual cutting tests have been made on a number of machines to demonstrate that the Boice-Crane cuts faster and with less effort. The results, shown on the accompanying chart, prove that the Boice-Crane band saw not only cuts two to four times faster but does it with the same feeding effort. In actual production, double output is easy with 25% to 50% reduction in operator fatigue.

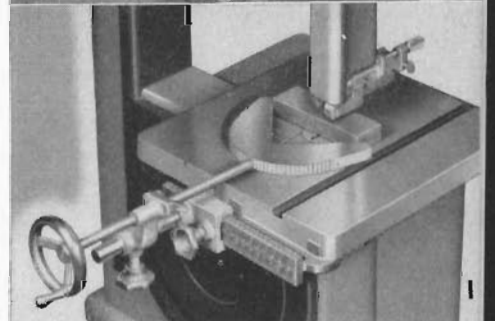
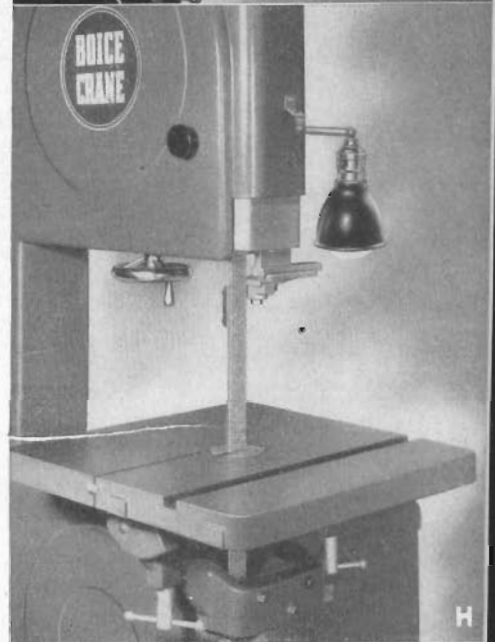
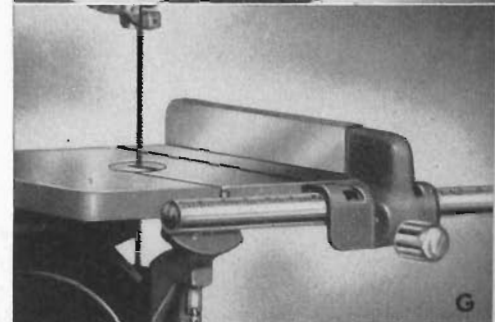
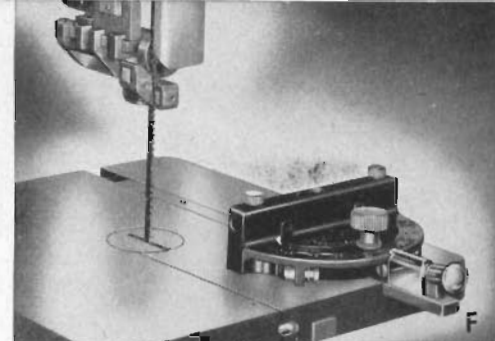

ACCESSORIES FOR INCREASING WORK RANGE AND EFFICIENCY FOR WOODWORKING MITER GAUGE (F)

Same gauge as on No. 2505 Saw. Improved. Quick setting. Extremely accurate. Handy and valuable for cutting precise miters and angles.

No. 2502 Auto-Set Miter Gauge. Ship. wt. 4 1/2 lbs.

RIP FENCE (G)

A highly valuable accessory. Micro-set and lock identical with our No. 2505 Saw fence. Accurately calibrated by 1/16's. Quick setting. No interference when changing blades. 18-inch front and rear bars for cutting widths up to 13 inches wide maximum; or 32-inch bars for 27-inch width of cut.

No. 2302 Rip Fence Attachment with 18-inch front and rear bars. Ship. wt. 18 lbs.

No. 2303 Same but with 32-inch bars. Ship. wt. 23 lbs.

WORK LAMPS—BUILT-IN AND SWIVEL TYPES (H)

Each Band Saw fitted to receive this handy light. Built-in. Out of the way. No broken bulbs. Concentrates light directly on table. Improves accuracy. Eliminates eye strain. A necessity for night work or dark shops.

No. 2321 Work Lamp Attachment, including reflector, socket, switch, cord and plug. Ship. wt. 2 lbs.

No. 2322 Lamp Bulb for above for 110 volt. Shipping wt. 4 ozs.

Double pivoted arm, reflector type lamp. Preferred by some, because of its focus feature. Built-in switch. Uses standard bulbs. See illustration H.

No. 115 Machine Lamp complete with bracket, double swivel arm, 8-foot cord and plug, attaching screw. No bulb. Shipping weight 1 lb.

METAL WORKING ACCESSORIES SCREW-FEED ATTACHMENT (I)

Holds flat pieces of all shapes—square, hexagonal, and round without further clamping. Exclusive feature is a swivel, compensating adjustment to quickly and easily match the actual feed direction to the "natural lead" of any blade. Straight cuts assured because operator has complete control over cut... blade life is lengthened too. Lateral lead-screw adjustment provides easy means for sawing accurate curves. Half-nut speeds set-ups. With this screw-feed the Boice-Crane cuts 1-inch cold-rolled steel rapidly—2 linear inches per minute. Big machines seldom saw faster.

No. 2307 Screw Feed Attachment, including universal toothed feed segment, and complete in-feeding and transverse adjusting mechanisms, also table bar. Shipping weight 16 lbs.

BLADE BUTT-WELDER (J)

A necessity for "inside" cutting on dies, blanks, and production parts. Greatly enlarges work range of our Nos. 2308 and 2309 Metal Cutting Band Saws. Reduces operating costs in woodworking as well as metal working plants by quickly making finished blades from coil stock.

Makes a band saw used for woodworking versatile like a jig saw, on inside, inserted-blade cuts.

Complete. Automatically welds, anneals, all blades 1/2 inch wide. Learn to operate in a few minutes. Two models, identical except one includes motorized grinder, the other at lower cost provides a vise for filing off the weld burr. Stocked only for 110 volt, 60 cycle, 1-phase A.C. Write for prices on other voltages.

No. 2312 Automatic Electric Blade Butt-Welder, complete with vise for filing weld burr, also includes cord and plug. Overall size 9"x7"x9" high. (Same as illustration "J" except no grinder).

No. 2313 (Illustrated.) Same as above but also includes motorized grinder for removing weld burr, and grinder switch. Overall size 11"x7"x15 1/2" high. Shipping weight 60 lbs.

SANDING—GRINDING ATTACHMENT (H)

For wood, metal, plastics. Makes your Band Saw a double-purpose machine. Quickly, easily attached. Dozens of uses. Belts stocked—garnet for wood, aluminous oxide for metal, plastics.

No. 2330 Band Sanding-Grinding Attachment Complete with platen, platen holders, table insert (for use on 2300, 2301, 2304, 2310, 2308, and 2309 Band Saws). Shipping wt. 5 lbs.

No. 2332 3—1" wide x 98" long, 50 Grit Aluminum Oxide Abrasive Belts for metal, plastics.

No. 2333 3—Same as No. 2332 except 80 Grit.

No. 2334 3—Same as No. 2332 except 120 Grit.

No. 2335 3—1" wide x 98" long, No. 1/2 (60) Grit Garnet Abrasive Belts for wood.

No. 2336 3—Same as No. 2335 except No. 1 (50) Grit.

No. 2337 3—Same as No. 2335 except No. 1 1/2 (60) Grit. Average Ship. Wt. 2 lbs.

BLADES FOR WOOD AND METAL

For WOOD	WIDTH	For METAL
Catalog NO.		Catalog NO.
2375	3/16"	2385
2376	1/4"	2386
2377	3/8"	2387
2378	1/2"	2388
2379	3/4"	2389

Above blades 98" cir. Av. ship. wt. 1 1/2 lbs. each.

NOTE: Listed above are blades normally stocked, selected for average conditions.

Special blades varying in temper, size and number of teeth, rake or set can be furnished for all sorts of materials. Consult us on specific sawing problems. No obligation. Prompt delivery on a particular blade to suit your specific needs.

TIRES—TIRE CEMENT

Band Saw wheel tires naturally deteriorate in time like any rubber products. Keep a "live," properly crowned set on your machine for best results.

No. 2305 Rubber Tire. Shipping weight 8 ozs. each.

No. 2306 Tire Cement. One pint. A special formula for bonding rubber tires to plastic wheels. Ordinary cements are not successful on plastic. Shipping weight 2 lbs.

MODELS SUITED TO MANY NEEDS AND CONDITIONS

SINGLE SPEED BAND SAWS

DIRECT DRIVE

The two Direct-Motor-Drive models are the most popular with woodworkers. Available in bench or floor type. Efficiently powered. Lower wheel mounted directly to motor shaft. No gears, belts, couplings, or unnecessary parts to wear, no motor power wasted.

NO. 2300 Bench Model, 14-inch Direct-Drive Band Saw, including one $\frac{3}{8}$ " wide wood cutting blade. No motor or floor stand. Illustration K. Shipping weight 197 lbs.

NO. 2301 Floor Model. 14-inch Direct-Drive Band Saw, same as No. 2300 except has cabinet base. No motor. Shipping weight 334 lbs.

DIRECT-DRIVE MOTORS FOR ABOVE

No.	H.P.	Voltage	Cycle	Phase	Price
2311	$\frac{1}{2}$	110-220	60	One	
2318	$\frac{3}{4}$	220-440	60	Three	
2319	1	220-440	60	Three	

Average Shipping Weight 75 lbs.

Be SURE to specify single VOLTAGE for switch connections. Direct-Drive motors for 50 cycle, A.C.; and for Direct Current . . . write for prices.

V-BELT DRIVE

Our V-Belt Drive Band Saws are designed to meet the needs of woodworkers who prefer belt drive, who may already have their own motor, or who out of necessity are forced to drive by gas-engine or lineshaft. Except for the method of driving they are exactly the same as the direct-motor-drive models and are full ball bearing throughout.

NO. 2304 Bench Model, 14-inch Belt-Drive Band Saw with $\frac{3}{8}$ " wide blade and 6" diameter V-pulley. No motor. Illustration L. Shipping weight 230 lbs.

NO. 2310 Floor Model, has cabinet base, otherwise same as No. 2304. No motor. Shipping weight 367 lbs.

NO. 1014 V-Pulley, 4" diameter for motor.

NO. 1060 V-belt, 60" circumference.

MOTORS FOR ABOVE V-BELT DRIVE MODELS

No.	H.P.	Voltage	Cycle	Phase	Bearings	Ship. wt.	Price
1455	$\frac{1}{3}$	110	60	1	Ball	34	
1457	$\frac{1}{3}$	220	60	1	Ball	34	
2345*	$\frac{1}{2}$	110-220	60	1	Ball	75	
2346*	$\frac{3}{4}$	110-220	60	1	Ball	75	
2348*	$\frac{1}{2}$	220-440	60	3	Ball	75	
2347*	$\frac{3}{4}$	220-440	60	3	Ball	75	

*Include switch for flush mounting on front of machine, also ten-foot cord and plug on 1-phase motors only.

Be SURE to specify single VOLTAGE for switch connections. Motors for 50, 40, 30 and 25 cycles, A.C.; and for Direct-current are also available . . . write for prices.

8-SPEED GEAR DRIVE BAND SAWS

The Boice-Crane Metal Sawing Band Saw has 8 speeds . . . one to suit every kind of blade and to efficiently saw every kind of material. Available in bench and floor models. The same strong all-welded vibrationless steel frame previously described on page 24.

The Boice-Crane 8-speed multiple purpose band saw is equipped with quick-change gear box and multi-groove pulley drive. (See illustration "M" at left). An efficient speed is instantly available to the operator for cutting a wide range of industrial materials—iron and steel; brass and copper; aluminum and zinc; brake lining; plastics; building board; fiber and paper; wood and plywood; even meat and fish. Also recommended for tool and die work. Our efficient blade butt-welder accessory makes it the equal (up to its capacity) of large die-shop band saws. Cuts up to 1" thick tool steel and softer materials proportionately thicker.

Precision-built gear box drive (see illustration "M" at left) contains seven large anti-friction ball and needle, or roller bearings. Quick acting shift-lever and clutch disengages or engages gears. The helical gears are $1\frac{1}{8}$ " and $\frac{3}{4}$ " wide and have heavy 12-pitch teeth; transmit as much as one horse-power at lowest speed with a large margin of safety. All gears hardened and run in oil.

The gear-shift lever and V-belt are easily accessible for speed changing through a hinged, spring-latch door. Both oil-filler and oil-drain plugs also accessible through door of drive compartment.

The gear-box unit and motor are both housed entirely within the base cabinet and thereby efficiently sealed off from destructive dust and grit.

NO. 2308 Bench Model, 8-speed Band Saw including gear-box drive unit, complete with 4-step vee (drive) pulley; one $\frac{3}{8}$ " wide metal-sawing blade; No. 1058 V-belt, and No. 1101 4-step pulley for motor shaft. Less motor, and screw-feed device. Illustration N. Shipping weight 320 lbs.

NO. 2309 Floor Model. Same as above with cabinet base. Shipping weight 427 lbs.

MOTORS FOR ABOVE GEAR DRIVE MODELS

No.	H.P.	Voltage	Cycle	Phase	Bearings	Price
2345	$\frac{1}{2}$	110-220	60	One	Ball	
2346	$\frac{3}{4}$	110-220	60	One	Ball	
2348	$\frac{1}{2}$	220-440	60	Three	Ball	
2347	$\frac{3}{4}$	220-440	60	Three	Ball	

Average Shipping Weight 75 lbs.

Include switch for flush mounting on front of machine, also ten-foot cord and plug on 1-phase motors only.

Be SURE to specify single VOLTAGE for switch connections. Motors for 50, 40, 30 and 25 cycles, A.C.; and for Direct-current are also available . . . write for prices.

ALL PRICES F.O.B. FACTORY AND SUBJECT TO CHANGE WITHOUT NOTICE

Any National or State tax now or subsequently levied is to be added to price quoted. We reserve the right to make changes in design, specifications, or equipment at any time without incurring any obligation to install these on any machines already sold.

Boice-Crane products manufactured and sold under the following patents either owned by Boice-Crane or under which we are licensed:

1,790,288	1,967,791	2,166,703	2,347,764
1,894,010	2,049,044	2,211,050	2,347,765
1,902,270	2,049,045	2,256,607	2,371,731
1,922,151	2,107,174	2,260,635	2,384,364
1,927,477			2,431,605

Design Patent Nos. 113,369 115,779 131,216
Other United States Patents Pending

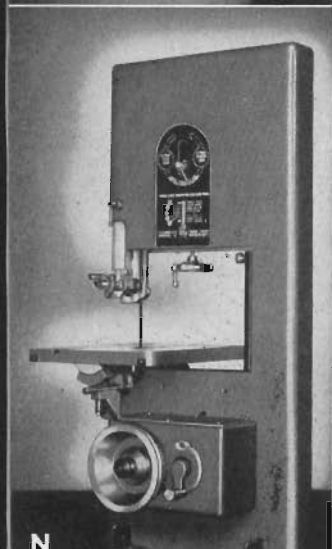
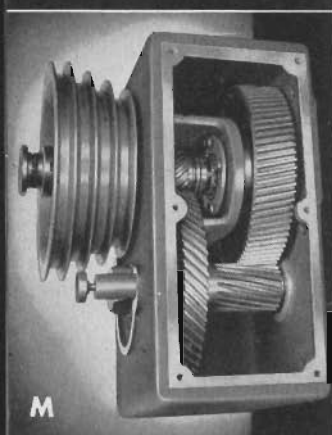
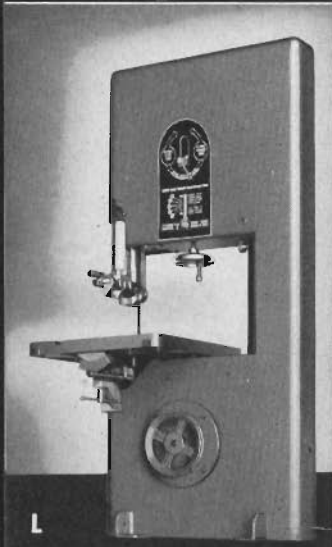
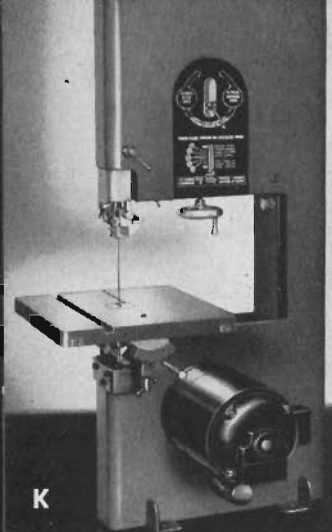

BOICE-CRANE

No. 2200

24" x 5" JIG SAW

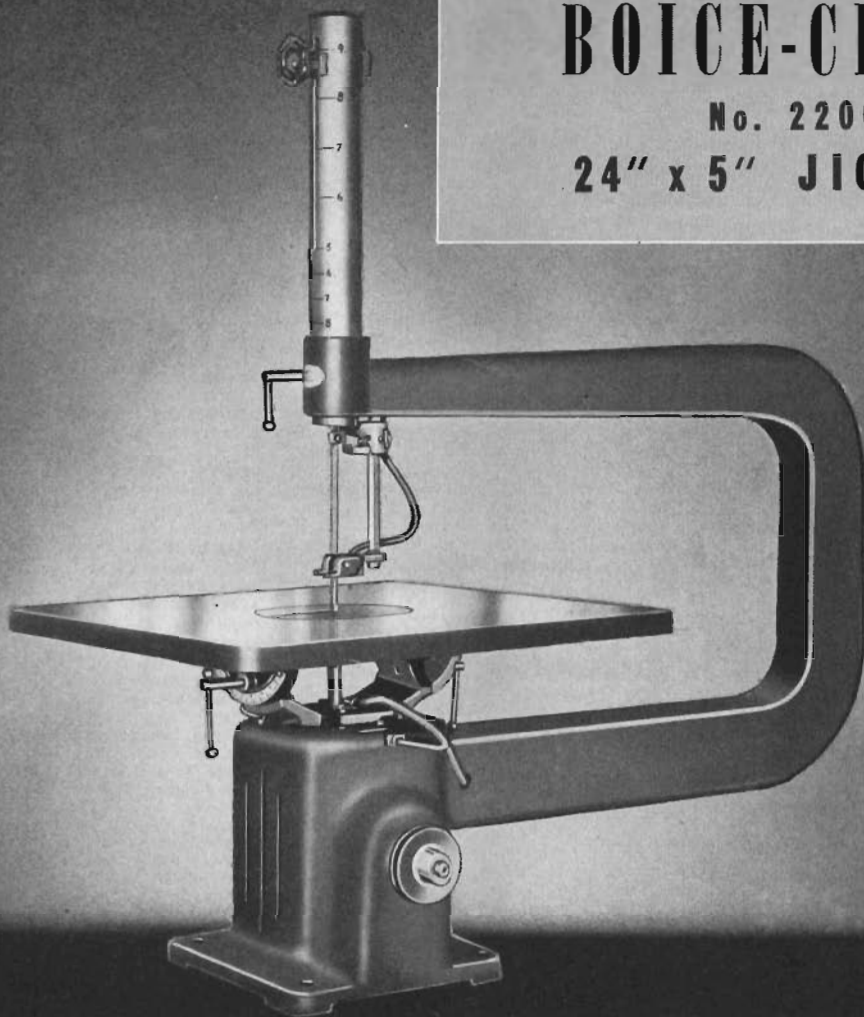

BIG WORK TABLE . . . 20 INCHES SQUARE . . . TYPIFIES ITS EXTRA CAPACITY

Big capacity. Cuts two thicknesses of 2" thick material or 16 pieces of ¼" (a total of 4") in exact duplicate pattern all at one time.

Uses blades 5 to 9 inches long. The long 1½-inch stroke cuts extra rapid.

If ever a jig saw was designed for the convenience of the operator, and with extreme versatility in the variety of work it performs, it is this DeLuxe Boice-Crane Jig Saw.

It is built with costly precision, has extra large capacity and ruggedness for sawing thick heavy materials. Then from a jig saw with strong spring tension on heavy sawing, it can be transformed in an instant by the convenient spring tension control to a sensitive, light-action scroll saw that is equally wonderful for cutting the most delicate scroll work such as inlaying or marquetry.

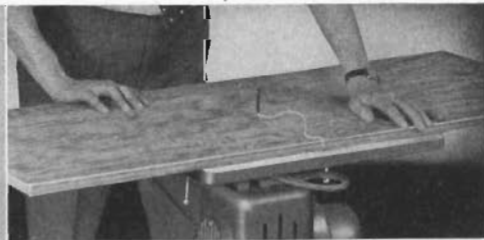

In these two views, see how ripping capacity equals that of costly 24-Inch Band Saws. Notice how blade guide, hold-down, air blower, and tilt-of-table are all in proper positions for full extent of use. You can even rip 45-degree bevels on long lumber. You get unheard of versatility in this big deluxe jig saw—combined with band-saw capacity—all in one machine. Woodworkers owning the Boice-Crane DeLuxe Jig Saw seldom need a band saw too. So again, a Boice-Crane saves you real money. Belt is completely guarded.

By removing U-Frame from base casting, and by using Sabre Saws as illustrated above, there is no limit to the size of panel that can be cut. Lower thrust guide, just below table surface, holds blade up to the work. Sawing is accurate. Frame is relocated by tapered dowel pins to exact original alignment.

SAWS THRU 5-INCH THICK STOCK... SAVES COST OF A BAND SAW TOO!

Check all makes and you won't find another with such complete versatility. That is why we call the Boice-Crane a SCROLL and JIG SAW. It does the work of both types of machines—from light scroll work to heavy jig sawing. Also does die-filing, saber-sawing, and sanding.

Furthermore, the Deluxe Boice-Crane is so capable in handling the heavy work of curved sawing (with its big work-table, deep 5-inch thick sawing capacity, and its deep 24" frame) that home craftsmen have little or no need for a band saw too. This Boice-Crane Scroll and Jig Saw does all the curved sawing that arises in the average shop.

UNIQUE 11-FEATURE UPPER HEAD FOR COMPLETE VERSATILITY IN EVERY USE

Measured Calibrations on upper head show Tension correct amounts of spring-tension to apply to every kind and size of blades. No guesswork. You simply lift Boice-Crane's tensioner knob—to desired calibration—and clamp it there. Quick. Easy. Always the correct tension.

Correct Tension If any jig saw is started with At Very Outset too little tension on blade—Saves Blades the blade buckles and is damaged; or if too much tension—the blade snaps. The damage happens the instant you snap on the switch, long before any correction could be made. Consequently, correct tension must be applied to blade before machine is ever started. Boice-Crane's Measured Tension does that, and guarantees longest possible blade life and economy.

Instant Tension Still another time saving feature. On every blade change. Boice-Crane's Release Upper Plunger is free of all tension. With no spring tension to work against, you clamp blades easiest, and get perfect blade alignment in exceptionally fast time, and every time.

Double-Bearings For Upper Plunger Accuracy Two long wearing bronze bearings, widely spaced, guide upper plunger in an accurate, vertical stroke. Blade can not go askew at bottom of stroke as on a single bearing. This Boice-Crane construction gives a lifetime of accuracy and greatly prolongs blade life.

Has Plunger Positioner Boice-Crane's tensioner knob is also your "plunger positioner" too. Only obtained in Boice-Crane. Often times the upper plunger of any jig saw gets drawn up tightly into its bearings, particularly after a blade has broken. On Boice-Crane, you merely unclamp the tensioner knob as usual—and push it down against plunger to free it and to reposition it—all in one easy motion. Now blade is easily inserted into chuck. No time wasted.

Takes Blades Long Upper head housing has vertical adjustment of 4 inches so you can use blades of different lengths. This broadens the capacity and versatility of this jig saw many times over ordinary ones. Calibrations for 5, 6, 7, 8, and 9" long blades show correct position for upper head—for each blade length. Never shifts. Saves you time and money.

Upper Head May Be Turned For Ripping Easy to read, scribed lines indicate exact position of head for ordinary sawing, or for ripping crosswise to frame. No chance of misalignment. No wasted time setting up.

Blade-Guide And Hold-Down Whenever you have occasion to turn upper head, Follow Around As the blade-guide, blower, Head Is Turned and hold-down all follow around as one unit—and perform their duties perfectly with no further adjustment. A time-saving Boice-Crane feature for your convenience.

You can always tell a Boice-Crane by its feature Upper Head. It makes it look different... makes it perform differently too than any other jig saw. This Upper Head alone gives you 11 extra features, and that super-performance you have always heard craftsmen enthuse over.

Oil-Soaked Wool Packing Really Lubricates Many a blade is saved from breakage by Boice-Crane's fully lubricated, free running upper plunger. No tightness, no sticking with lubrication like this.

Upper Head All Over A mere glance at the highly Nickel-Plated Head Casting (it is 16" long by 2" diameter) indicates real quality of workmanship. Every adjustment you make is easy. Bold calibrations, easy to read. Stays bright, slides freely for years.

Oil Trap Catches Any Oil Seepage Any oil seepage always gathers on a low dimple of metal, and when oil falls, it falls squarely into the Oil Trap—never on your work. This unique design is again indicative of the exhaustive way in which Boice-Crane constantly strives to give you perfect machines—for perfect performance.

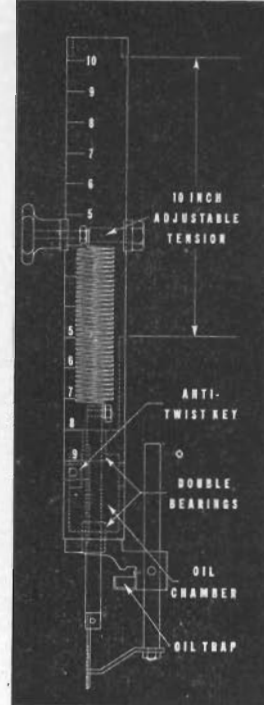

Patent No. 2,107,174

No. 2200 24" x 5" Jig Saw with six assorted 3" long fret blades one 1/4" x 8 3/4" long jig blade. 3" diameter V-pulley No. 2210 belt guard and wrenches. Ship. wt. 178 lbs.

No. 1012 V-Pulley, 2" dia. for motor. Drives jig saw at 1100 r. p. m. Ship. wt. 8 oz.

No. 1044 V-Belt, 44" circumference. Ship wt. 8 oz. ..

No. 2203 Steel Stand and switch rod. Ship. wt. 45 lbs. .

No. 1601 Motor, 1/4 h. p., 1750 r. p. m., one shaft with built-in switch. Ship. wt. 33 lbs.

No. 2208 Complete motor-driven Jig Saw on stand. Ship. wt. 257 lbs.

No. 2210 Belt and Pulley Guard. Ship. wt. 4 lbs.

Fret, Jig Saw Blades for Wood, Metal, Plastics—Page 38



Iron, brass, copper, pewter in either sheet or tubing, as well as materials like bone, bakelite, ivory, aluminum, die-castings, and many others are all sawed fast and clean using fret or hack saw blades. Consult our engineers.

For blades, see page 38.

Open side Blade Chucks hold finest jewelers to heaviest hack saw blades—centrally and vertically. Easily cleaned. All hardened steel. Jaws won't wear rough, or become bent or worn under continued clamping, thus failing to hold blades. Quick. Positive. Full blade range capacity.

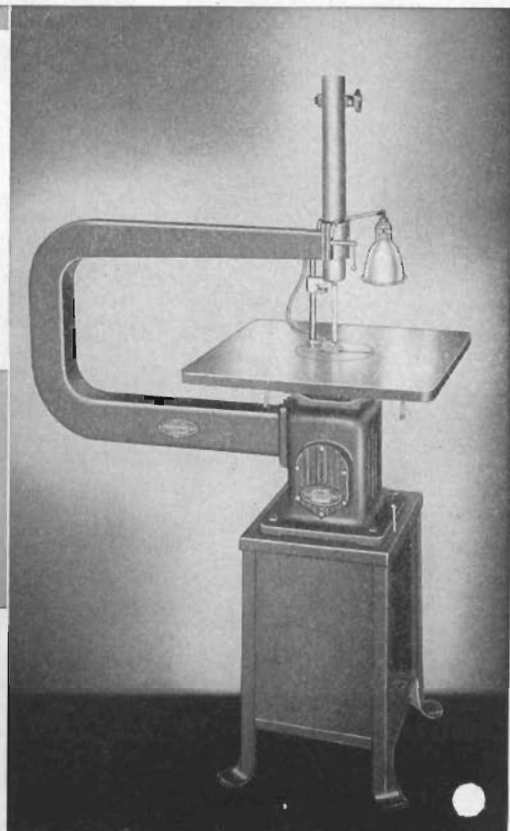

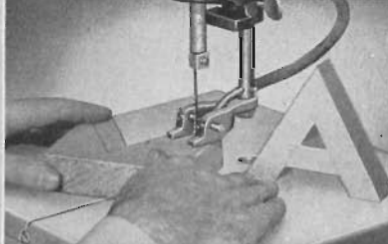
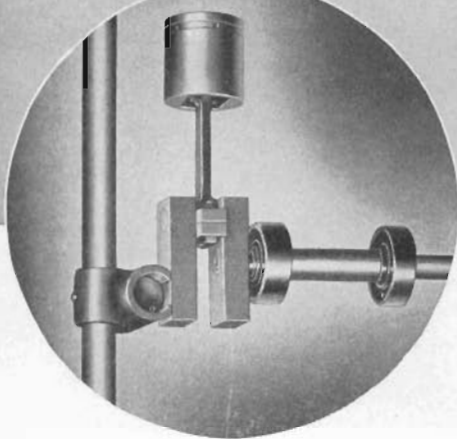

Full sets of letters in any size ranging from characters 3" high out of 3/4" stock, up to characters 12" high from 3" stock, are sawed out easily. The Boice-Crane is the only low cost Jig Saw which has deep enough capacity for sawing the thicker materials that jobs like this require.



Sanding flat edges or into corners is an easy task. Saves tedious hand labor.

BALL BEARING *Balanced* DRIVE!

Crank shaft revolves on highest quality ball bearings. They give a lifetime of accurate service, sawing heavy materials at high speeds. Likewise, as there is so little friction, the finest fret blades give excellent service and have long blade life.

Notice the Balanced Action of the drive. As blade-pistons move up, large air-piston moves down—weight of one counterbalances the other. Consequently, Boice-Crane's Deluxe Jig Saw reaches high speeds without slightest vibration.

OPERATES IN MASSIVE OIL-TIGHT CRANKCASE

The finely balanced Drive Mechanism consists of a bronze cross-head, hardened steel cross slide, and a steel crank shaft—mounted upon highest quality ball bearings. All moving parts are fully splash lubricated. Connecting rod of air pump is also bronze, and its bearing has take-up adjustment for any wear. The Boice-Crane Drive Mechanism is the strongest used on any bench jig saw on the market. Furthermore our 50% longer blade-stroke clears blades rapidly, and cuts thicker stock, faster. Boice-Crane's Jig Saw is heavy duty ALL THE WAY THRU—in construction, in table capacity, in sawing capacity—yet has the light sensitiveness of finest scroll saws for light-duty work.

U-FRAME IS FREE FROM BENCH DISTORTION

The Base, handsome in its modern styling, is a heavy single iron casting with a broad flanged foot for bench mounting. Standing firmly on its one massive foot, the Boice-Crane Jig Saw has the appearance of big costly industrial machines, and performs like one too. You can bolt this Jig Saw to the most uneven bench surface without the slightest possibility of ever distorting the U-frame and the upper plunger alignment from the lower. Year after year with Boice-Crane, you'll experience permanent accuracy and enjoy the thrill of smooth running, versatile performance, unequalled by any other.



Sanding of curved edges is likewise readily done with ease and accuracy.

SPECIFICATIONS

Capacities. Table to upper chuck. 5 1/2"
Blade to frame. 24"

Table. Machined cast iron. Has removable throat ring. Tilts 45 degrees, also turns and tilts 45 degrees. Size 20"x20"

Sawing capacity under hold-down. . . 5"

Stroke of Blades. 1 1/2"

Length of blades, overall. 5 to 9"

Blade Guides above and below table. Yes

Air Jets above and below table. . . . Yes

Motor H. P. recommended. . . . 1/2 or 3/4

Overall: 39" high; 20" wide; 38" deep.

Weight less motor. Net 133 lbs.

Crated 178 lbs.

A BIGGER TABLE HERE — THAN IN MOST BAND SAWS

Boice-Crane's Table (20" x 20") contains nearly THREE SQUARE FEET of area, or in other words 2 to even 3 times more area, to give just that much more support to your work, than ordinary jig saw tables. Only in Boice-Crane do you get a table, industrial capacity in size, something you have always wanted in a jig saw and which now you can afford.

Now, all your work having long sweeping curves, your big panels, your "inside" sawed work that has always been difficult to handle on a smaller table, and your saber-sawing of panels as big as they come—are all fully supported. Your work is ever so much easier, and more accurately done. Production is faster, your costs lower. Boice-Crane's Deluxe Jig Saw is a real value. Every shop wanting a jig saw of "Industrial" size and performance—at low price—should order now.

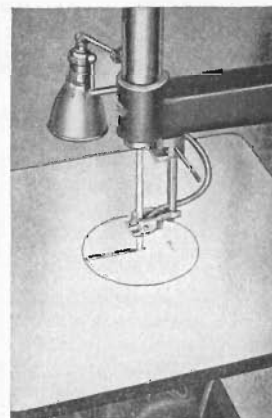

Only a table the size of this one handles largest panels with ease and accuracy. Machined cast-iron, with smooth, highly polished surface.

JIG SAW FILES



No. 910 THREE SQUARE

Files for metal. Specify those wanted by number. Each

Six, assorted

- | | | | | | |
|-----|------------|-----|---------|-----|---------|
| 911 | AURIFORM | 914 | ROUND | 918 | PILLAR |
| 912 | OVAL | 916 | KNIFE | 919 | LOSENGE |
| 913 | HALF ROUND | 917 | CROCHET | 920 | SQUARE |



CHUCKS

This Chuck has been especially designed to rigidly hold metal files in exact alignment with the plunger, so very accurate filing can be done.

Entire length of file shank fits firmly into deep socket of chuck, and is gripped tightly by a hollow-head set screw. Square, or 3-Square files cannot possibly rotate in chuck as might occur on chucks with less grip.



No. 2206 Chuck for holding files with 1/4" dia. shank
(For No. 2200 Saw only)

BOICE-CRANE

No. 2000

SPINDLE SANDER



Super LUBRICATION

The Boice-Crane crank case is filled ONCE A YEAR with 3 to 3½ QUARTS of fresh oil to indicated level. None can leak out. Dust can't enter. Fully lubricates every internal part. The oscillating bearing is doubly sure lubricated too. This is grease-packed at factory. Needs extra grease but once or twice a year. Fully sealed too against dust and leakage.

With such positive lubrication, every Boice-Crane user is sure of years of accuracy—with not a penny for repairs. Your first cost is your final cost.

FEATURES

Select this Boice-Crane Oscillating Spindle Sander for the sanding jobs in your shop that are slow and difficult by hand. Saves hours and hours of hand work. Improves every project or product. Make your hobby more enjoyable and save real money on commercial work.

Before selecting any type of sander, check over the hand sanding jobs that are pure drudgery, and those that eat up profits fast. You'll find most of them jobs that this Spindle Sander will run fast and easy. (A few will be jobs you can handle on an inexpensive disc attachment. And those that involve large flat expanses like table tops are jobs for our belt sander.)



Here you see the SMALLEST diameter abrasive sleeve ever used on any spindle sander. Inside diameter only ¼ inch. Usually 2" is smallest. Our full assortment of sizes, ¾", 1½", 2", and 3", handles every class of work in any shop.

Boice-Crane table, 20" x 20", compares with machines priced 3 to 5 times higher. Perfectly flat, highly polished. Two scribed Index Lines on table show exact positions for beveling, drafting patterns, and for core-box work.

ONLY A SPINDLE SANDER HANDLES THESE 10 JOBS

1. Sands any length curved edge. Convex curves. Concave curves to as sharp a radius as ¼".
2. Sands any degree of bevel on curved or straight work up to 6 inches in height, to any length.
3. Sands inside of holes over 1" dia.
4. Sands curve sawed edges smooth, which are to be run against rubbing collars of a Power Shaper, thereby guaranteeing smoothest possible shaping.
5. Sands or Grinds perfect "draft" on wood or metal patterns. Leaves no "back-draft" at any point.
6. Sands straight edges, or straightens face of materials up to 6 inches in width, and to any length—by the addition of our regular No. 2130 shaper fence. See page 4.
7. Grinds aluminum, brass, or die-castings.
8. Grinds sheet iron for templates.
9. Sands those faces which blend gradually thru different slopes at successive cross-sections. A most simple job on this spindle sander—yet entirely impossible on any other sander.
10. Sands "glued-up" work 6" high.

With all these jobs of every day occurrence to perform, a Boice-Crane Spindle Sander leads in usefulness. It merits your first choice. Pays more dollars in profit. Decide NOW on a Spindle Sander for your shop, and order a Boice-Crane today.

Garnet Sleeves with Cardboard Back			Length 9"		Emery Cloth Sleeves Without Cardboard Back		
No.	Grit	Price for 6	Inside Dia.	Ship. wt. ½ doz.	No.	Grit	Price for 6
2061	1		¾"	1 lb.	2072	½	
2062	1		1 ½"	2 lbs.	2073	1	
2063	1 ½		1 ¾"	2 lbs.	2074	1 ½	
2064	1		2"	2 lbs.	2075	1	
2065	1 ½		2"	2 lbs.	2076	1 ½	
2066	1		3"	3 lbs.	2077	1	
2067	1 ½		3"	3 lbs.			

No. 2001 Rubber Drum, 1½" dia. Ship. wt. 3 lbs.

No. 2002 Rubber Drum, 2" dia. Ship. wt. 3 lbs.

No. 2003 Rubber Drum, 3" dia. Ship. wt. 5 lbs.

(No rubber drum needed for ¾" dia. sleeves.)

Oscillating SPINDLE

Sand Drum oscillates automatically thru $\frac{7}{8}$ inch long stroke —83 complete strokes at 2,500 revolutions per minute. The oscillating drum always sands silky smooth, even with the coarsest abrasives which are faster and freer cutting, and which don't clog readily. Coarse abrasives on non-oscillating drums score the work. The wear on Boice-Crane abrasives is evenly distributed. Less clogging between grains. The abrasives stay clean, cut smoothly, and last for a long time to lower your operating costs.

LOW COST COMPLETE UNIT

This motor driven Boice-Crane on floor stand is very compact. Readily portable. An amazingly efficient, complete Power Sander at very low cost. Try one for 10 days.

- No. 2000** Spindle Sander with $\frac{3}{4}$ " and 2" dia. abrasive sleeves, 2" dia. rubber drum, 2 table rings, expanding collars, and V-pulley for belt drive. Ship. wt. 143 lbs.
- No. 1012½** V-Pulley, 2½" dia. for motor. Ship. wt. 8 oz.
- No. 1034** V-Belt, 34" circumference. Ship. wt. 8 oz.
- No. 1755** Motor, ½ h.p., 110 volt, 60 cycle, rep-ind. ball bearing, with built-in switch. Ship. wt. 34 lbs.
- No. 2005** Steel Stand with switch rod, and belt guard. Ship. wt. 65 lbs.
- No. 2006** Complete Spindle Sander on stand as itemized above. Ship. wt. 240 lbs.

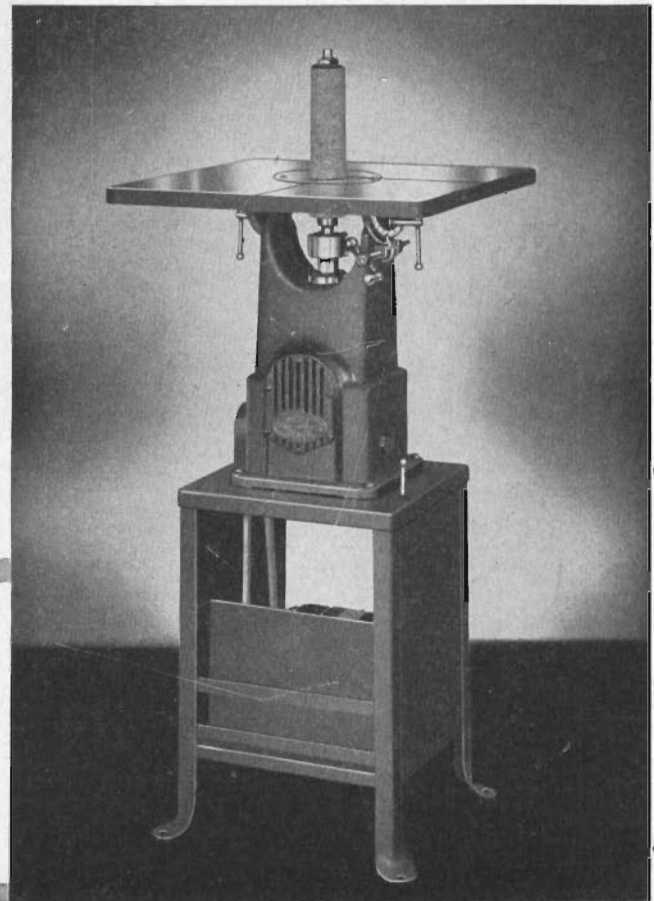

AND SANDER ACCESSORIES

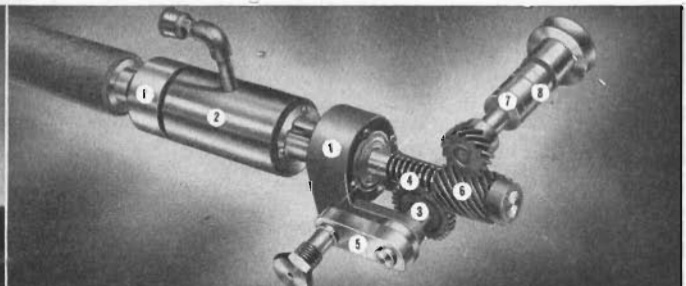
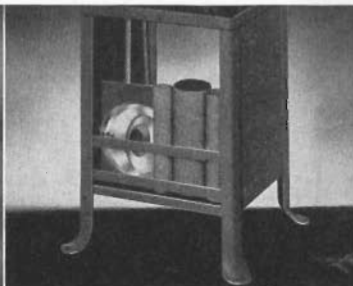

Table tilts 45° Both Directions on two extra large, closely fitted, machine-cut trunnions. Sensitive adjusted by worm and worm-wheel.

Double locking levers hold table rigid at every angle. Degree scale fully visible as you tilt table.

Large storage compartment in the floor stand keeps all accessories and a large supply of abrasive sleeves right at machine. A most convenient time saver.

Left side panel shields v-belt. Motor controlled by ball-end switch rod within easy reach.

- 1 Two quality Ball-Bearings. Life lubricated.
- 2 Here, 12 Nichrome steel ROLLING BALLS for frictionless sand drum shaft. Grease filled and sealed housing.
- 3 Bronze bearings BOTH SIDES of worm wheel. Splash oiling.
- 4 Steel worm, and bronze worm-wheel. Runs in oil.

- 5 Bronze bushed connecting arm. lubricated.
- 6 Hardened Steel Gear for long wear. Runs quietly with mating steel spiral gear. Both run in oil.
- 7 Special Oil-Sealed Unit seals shaft against oil leakage.
- 8 Shaft built right into special New Departure. Double-Row, Ball Bearing. Life lubricated.

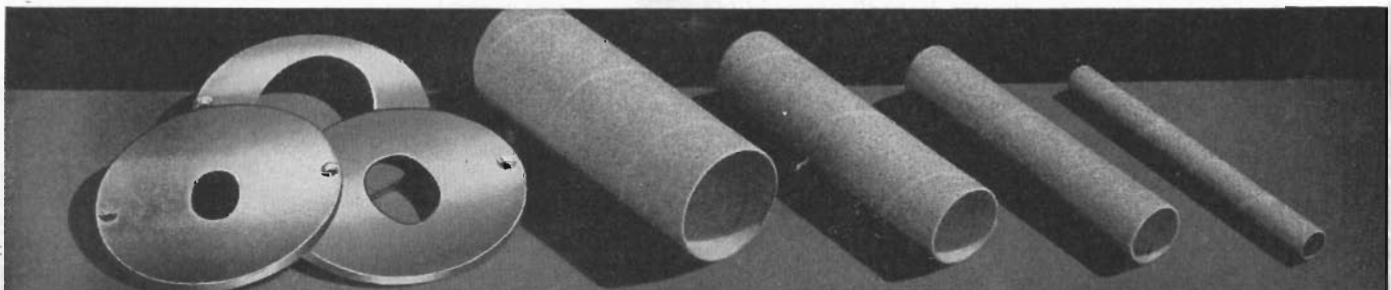

Abrasive sleeves spiral-wound into lapless cylinders. No joint. No bumps. Heavy cardboard retains perfect shape. Quickly and easily changed.

Rubber Drum No. 2002 is regular equipment. Very soft. Expanded by spindle-nut. Slight expansion grips sleeves firmly, without distortion.

Table Rings, $\frac{3}{4}$ " and 2" are regular equipment.

- No. 2023 Ring for 3" dia. sleeves . . .
No. 2022 Ring for 1½" dia. sleeves . . .

New BOICE-CRANE BELT SANDER *for* FLAT PARTS & LARGE CONTOURS

LARGE CONTOURS

WITH

Exclusive

**Height-O-Matic
V-BELT DRIVE**

Visible Operation

THE WORK IS
ALWAYS FACE-UP

**EXACTLY LIKE
BIG MILL-SIZE
SANDERS**

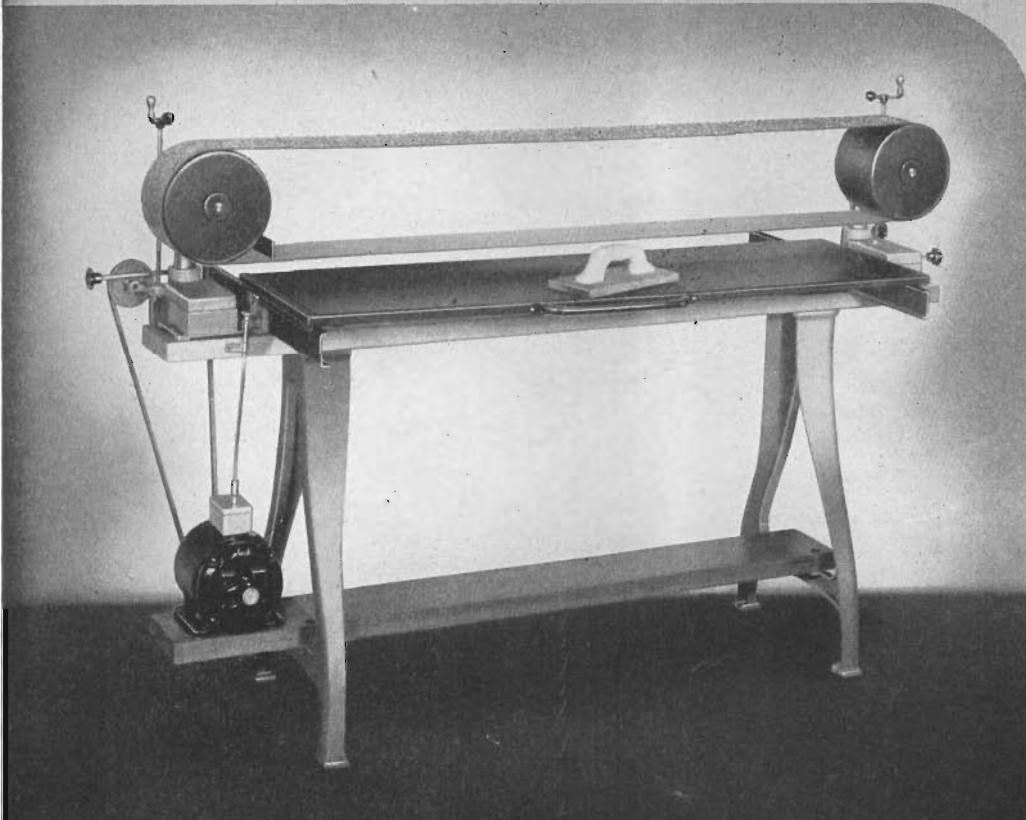

INSTANT CONTROL—Light “Spot” Touch-Up to Deep “All-Over Cuts”

Woodworking production men recognize in this Boice-Crane — the time-proven mill type sander in a more popular, compact size. Besides sanding wood parts, its uses include fine surface finishing of plastic and many metal parts. The oscillating motion so indispensable for fine finishes by mechanical means, is provided in this machine by a freely rolling work table. It also features instant and complete operator control—ranging from light “spot” touchups to heavy “all-over” cuts. It comes closer to being the ideal “all around” or general purpose sander-surfacer of any single type yet developed.

For Quick Surfacing of Wood, Metals, Plastic, Fibre

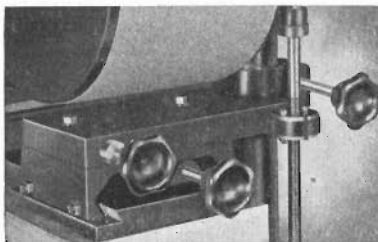

Belt Tension and Aligning Controls. Accurate lineup, and takeup for wear provided in dovetail construction shown.

The Boice-Crane is not limited to sanding wood. It grinds or surfaces, also polishes most any industrial material. Among them are steel parts, die castings in various metals, other cast aluminum, brass and copper parts. Also, plastics of all kinds, bone, fibre, ivory, and a host of others.

Refer your metal surfacing and finishing problems to us. On hundreds of jobs a Boice-Crane Sander-Finisher will show an improved finish at lower cost. Our recommendations include proper abrasive and speed.

Height-O-Matic Drive

Exclusive Height-O-Matic Drive maintains drive belt tension automatically, regardless of height of abrasive belt.

This efficient drive uses V-belts and powerful motors up to 1½ h.p. Large size needle-bearing equipped idler pulleys give longer belt life and increased power.

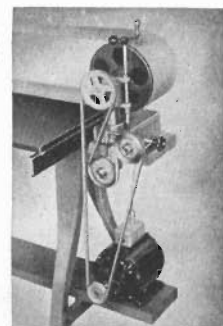

SPECIFICATIONS

Drums 10" diameter. 7" wide. Shell Type. Spun Steel
Work Table 18" x 60"
Table Fore and Aft Travel 18"
Abrasive Belts 6" wide. Cloth Back
Maximum Capacity ... Areas 36" w. x 60" long; 0 to 4" Thick
(Unlimited length capacity on stock 6" wide or under)
Power ½ h.p. Light; ¾ h.p. Medium; 1 h.p. Heavy Duty

Use As Drum Sander

The drums on the Boice-Crane are an ideal diameter for a big range of contour sanding, grinding and polishing.

This often saves the purchase of a second machine for this class of work only.

In many shops this one machine handles 75% to 85% of ALL sanding, grinding and polishing on flat and contour parts.

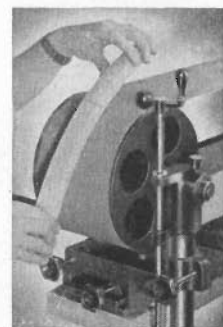

THE BOICE-CRANE BELT SANDER DOES MORE DIFFERENT KINDS OF SANDING JOBS

and **50% faster**

Industry uses 6 main types of mechanical sander-finishers. Generally speaking the Hand Stroke type undeniably handles a bigger variety of work than the rest. Its results on large flat surfaces are also far superior. In the Boice-Crane this basic advantage is further increased to as much as 50% faster production . . . directly traceable to our 6" wide belt, large work table, tremendous length capacity (20 ft. or more), and large powerful motors.

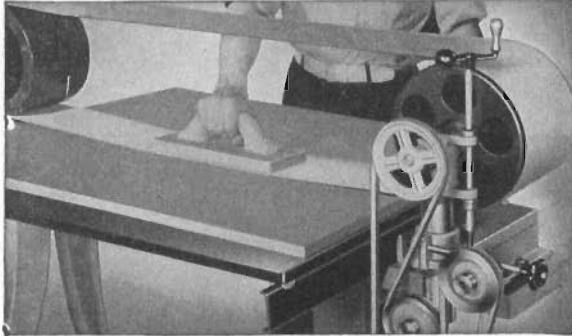

Face Up Operation . . . On a Boice-Crane the surface worked on is always toward the operator. He never loses time turning the part over to check results. No chance to take off too much and spoil the part. Guesswork eliminated.

Multiple Parts . . . For small wood, metal, plastic and fiber parts, multiple fixtures attached to table take dozens at a time. On long runs, one side of table can be unloaded and reloaded while surfacing those on other side.

Metal Finishers, Novelty Manufacturers, Fabricators of All Kinds of Metals, Wood and Plastics—All Use Them

The above industries head the long list of successful installations of Boice-Crane Hand Stroke Sander-Finishers. One of the most recent additional applications has been for refinishing painted

venetian blind slats on which original finish has to be removed. There is no limit to the ways in which this practical size, labor saving tool will speed up finishing in your own plant or shop.

- No. 1160** Belt Sander. Includes two drum units, Rolling Work Table with Table Rails, 1-14'1" Abrasive Belt and Hand Stroker. Ship. Wt. 200 lbs.
- No. 1161** Pair of Floor Legs. Includes wood top shelf, No. 1096 V-belt, No. 1013 V-motor pulley, bolts. Ship. Wt. 128 lbs.
- No. 1485** Motor, 1 h.p. with switch. Ship. wt. 69 lbs.
- No. 1165** Complete Motorized Sander. Includes all above equipment and No. 1485 Motor. Ship. wt. 419 lbs.
- No. 1147** 14'1" Garnet Cloth Belts for Nos. 1160 and 1165 Sanders. Shipping Wt. 1 lb. Each
- No. 1146** 10'1" Garnet Cloth Belts for former Nos. 1136 and 1140 Sanders. Shipping Wt. 1 lb. Each
Specify grit wanted— $\frac{1}{2}$, 1 or $1\frac{1}{2}$.
- No. 1172** 20'6" Garnet Belt. Grits $\frac{1}{2}$, 1, $1\frac{1}{2}$. Ship. Wt. 1 lb Each

No. 1170 BOICE-CRANE DRUM UNITS FOR MAKING YOUR OWN SPECIAL PURPOSE SANDER

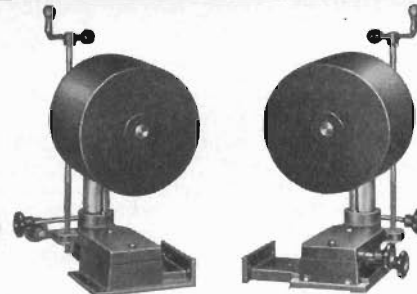

No. 1170 Drum Unit. Consists of both driven and idler drums as shown. No work table or belt. Belts listed column to left. Shipping weight 120 lbs.

BOICE-CRANE Cushioned Sander Drums

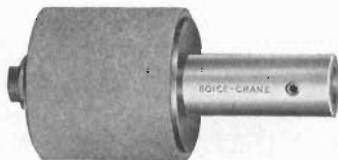

A valuable accessory for large and small shops. Used on any machine or motor arbor running 1750 to 3500 r.p.m. Satiny smooth finish from the "cushiony" action of the live rubber drums used. Our spiral wrapped abrasive sleeves leave no bumps to tear paper or mar work. No wedges needed. Sleeves 1" dia. used without drum.

- No. 554** Sanding Drum, 2" dia. x 3" long complete. Includes Attachment Spindle for $\frac{1}{2}$ ", $\frac{3}{8}$ " or $\frac{3}{4}$ " shaft (specify which), rubber drum, compressing washers and 1 abrasive sleeve. Ship. wt. $3\frac{1}{2}$ lbs.
- No. 553** Same, except includes 3" dia. x 3" long Rubber Drum.
- No. 525** 2" dia. x 3" Rubber Drum only with 2 compressing washers and 1 abrasive sleeve. Ship. wt. 2 lbs.

Garnet Paper Sleeves			Prices for $\frac{1}{2}$ doz.			Emery Cloth Sleeves		
No.	Grit	Price for 6	Inside Dia.	Length	Ship. wt. $\frac{1}{2}$ doz.	No.	Grit	Price for 6
565	1		$\frac{3}{4}$ "	3"	$\frac{1}{2}$ lb.	574	$\frac{1}{2}$	
			$\frac{3}{4}$ "	3"	$\frac{1}{2}$ lb.			
566	1		2"	3"	$\frac{3}{8}$ lb.	576	$\frac{1}{2}$	
			2"	3"	$\frac{3}{8}$ lb.			
567	$1\frac{1}{2}$		3"	3"	1 lb.	577	1	
			3"	3"	1 lb.			
568	1		3"	3"	1 lb.	578	$\frac{1}{2}$	
			3"	3"	1 lb.			
569	$1\frac{1}{2}$		3"	3"	1 lb.	579	1	
			3"	3"	1 lb.			

SPINDLE, DRUM AND BELT SANDERS—BOICE-CRANE HAS ALL 3!

SEE PAGES 15, 30 and 40

55% ADDED CAPACITY WITHOUT ANY EXTRA COST

THE LARGER, No. 1700 AND 1701 BOICE-CRANE GAP-BED LATHES

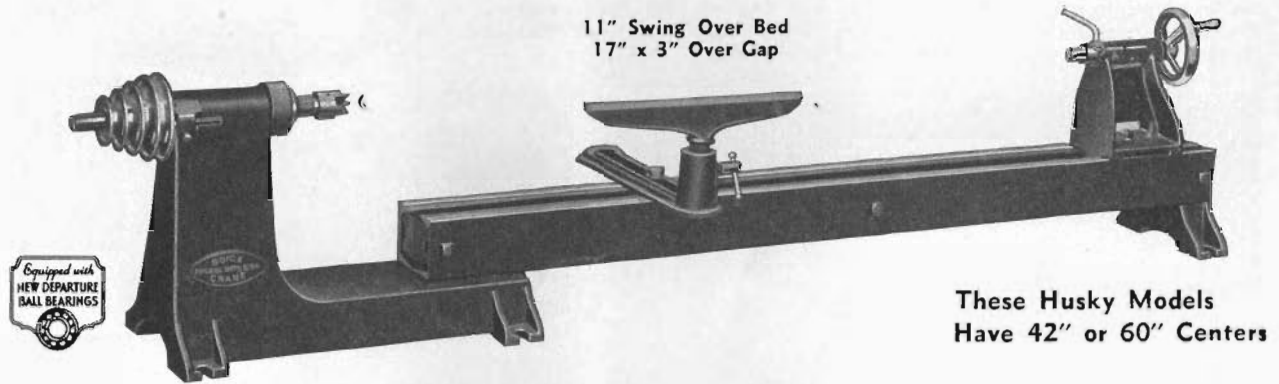

These Husky Models
Have 42" or 60" Centers

HEAVY DUTY, BALL BEARING. EVERY WORTHWHILE FEATURE INCLUDED

The No. 1700 GAP-BED Lathe is without question the very finest lathe we have ever built with so many desirable features included in it, all for a low price.

No. 1700 GAP-BED Lathe has very large capacities. It swings work over bed 11" diameter. The GAP-BED increases this normal capacity, so face plate turning can be swung over the bed in size up to 17" diameter x 3" thick. This is an increase of 55%.

The center distance is 42" on No. 1700; and 60" on the No. 1701 GAP-BED Lathes. Overall lengths are 60" and 78" respectively.

This greatly enlarged capacity, at a low price every craftsman can afford to pay, the sturdy construction and precision workmanship all through, and the many new features, all go to make the No. 1700 GAP-BED Lathe a favorite with pattern makers, cabinet makers, furniture, toy and novelty manufacturers, as well as home-craftsmen.

Every Part Designed for Severe Service.

From the bed up, every part of this big, husky lathe has been designed with heavy duty service in mind.

It is no ordinary bed that we use in this No. 1700 Lathe. Two structural steel sections, walls $\frac{3}{8}$ " thick, are bolted rigidly together and then carefully planed and milled along their full length on modern production machines. These beds will stand tremendous strains and are guaranteed not to spring. Centers cannot ever get out of alignment on such a bed as this. The headstock is doweled in place.

The bed is raised off the bench by gracefully designed legs. The open span under bed makes it easy to clean shavings off bench, prevents interior of bed from clogging full of shavings which would hinder adjustment of the sliding parts, and also provides a handy place to lay tools to be instantly available.

The headstock spindle in this de-luxe lathe is turned and ground from tough textured steel 1" diameter, to which are fitted best grade New Departure Ball Bearings. We use and recommend only ball bearings for such a high speed application. Ball bearings require no adjustment of any kind for the life of the machine.

Consistent with the large capacity of this lathe, the headstock and tailstock were designed to carry loads many times heavier than will ever be required of them. These parts are strong iron castings—not die-cast. Live spindle has a hole clear through, for chucking long rods or dowels. The nose of the live spindle is fitted with a deep, coarse thread for the various attachments for wood turning, metal turning, and metal spinning. Both spindles have No. 2 Morse taper sockets, and tailstock has a self-ejecting center feature.

No. 1700	Boice-Crane Gap-Bed Lathe with tee rest and holder, tailstock, taper shank spur center, taper shank cup center, and wrenches. Ship. wt. 100 lbs.
No. 1701	Same, except 60" c. to c.
No. 1101	4-Step Cone Pulley, for motor. Specify size of hole, $\frac{1}{2}$ ", $\frac{3}{8}$ " or $\frac{3}{4}$ ". Ship. wt. 2 lbs.
No. 1040	V-Belt, 40" circumference. Ship. wt. 8 oz.

STUDY THESE OTHER IMPORTANT FEATURES OF BOICE-CRANE GAP-BED LATHES

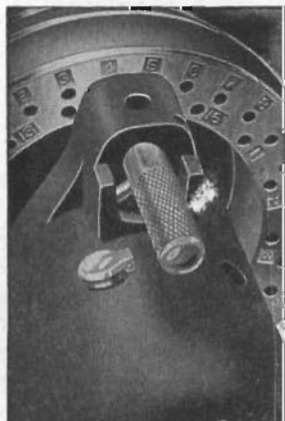

Indexing Device: All Boice-Crane GAP-BED Lathes have an improved indexing device, which is of considerable use in craftsmen's work as you will see below.

This device performs the most difficult and tedious jobs any craftsman ever encounters, namely the laying out of circular work into any number of equal divisions. Laying out exact positions for spokes in a wheel, or for bosses and holes in circular pieces are two examples. Many other uses will occur to you.

Another opportunity for use, which every craftsman will grasp at, time and again, is to lock the spindle from turning, so that you can use both hands on the face plates, to screw them on (or off) more easily.

It is also used to lay out flutes in a table leg so you can carve accurately between the marked lines; or if you own a portable router or flexible shaft you can make the actual fluting cuts while the table leg is held stationary between centers in the lathe, with the tee rest acting as a horizontal guide for the cutter.

The Boice-Crane indexing device is unique in several particulars. The index pin operates from the one position as shown, and will engage either of the two rows of holes. It divides a circle into a great number of practical divisions, namely 2, 3, 4, 5, 6, 8, 10, 12, and 18 equal parts. Every "division hole" is numbered, see photo, to simplify the use of the device and to eliminate errors that otherwise might occur from miscounting unidentified "divisions."

A small detail usually overlooked in bench lathes but included in all Boice-Crane Gap-Bed Lathes, is a calibrated tailstock spindle used in connection with accurate depth boring operations. An adjustable pointer is furnished to set at zero when the boring starts. The exact depth of the bore is right before the operator's eyes

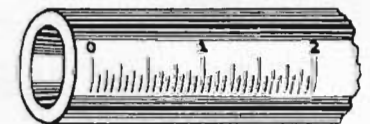

Calibrated Quill of Tailstock

at every moment of the operation. The scale is accurately calibrated in inches by sixteenths.

SUPER-RIGID CONSTRUCTION

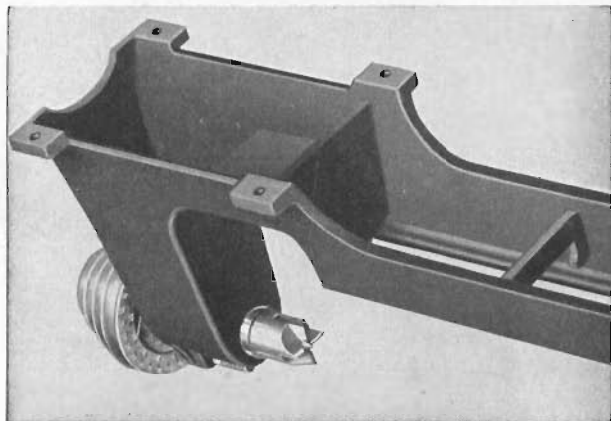

Regardless of the Boice-Crane lathe you select, its bed has these features:

1. Extra weight to prevent springing and to absorb vibration.
2. Thick steel walls, exceptionally strong, thoroughly cross braced, to keep all parts in alignment.
3. Span-type, to lift bed off bench. Permits slipping tools under bed where they are handiest. Makes cleaning up easy too, and prevents shavings clogging the inside of bed.

4-Step Cone Pulley: Steps are 4, 3.4, 2.8, and 2.2 inches in diameter. When two are used in combination with a 1750 r.p.m. motor, the following speeds are developed: 3180, 2110, 1450 and 960 r.p.m. These speeds are exactly right for woodturning and metal spinning up to 11" diameters.

Using the No. 1700 lathe for wood turning and metal spinning above 11" diameter slower speeds give better results. And of course for metal turning, greatly lessened speeds are absolutely necessary. We can furnish a countershaft developing 8 speeds for all these classes of work.

Countershaft for Slower Speeds: Use our No. 1708 Countershaft between lathe and 1750 r.p.m. motor. Selectivity of speeds by quick, easy shifting of belts, as follows: 4600, 3020, 2030, 1330, 940, 620, 415 and 275 r.p.m. This wide range will handle every job of wood and metal turning, or metal spinning possible on the No. 1700 lathe.

MOUNTED 4 AND 8 SPEED LATHE OUTFITS

These sturdy, compact, lathe outfits complete with stand, motor and switch, are the finest lathe units we offer. They are an extraordinary value too, especially for large homecraft shops, schools, pattern shops, repair shops, etc., because they are the equal of the floor type lathes costing three or four times as much. Choice of motors permitted.

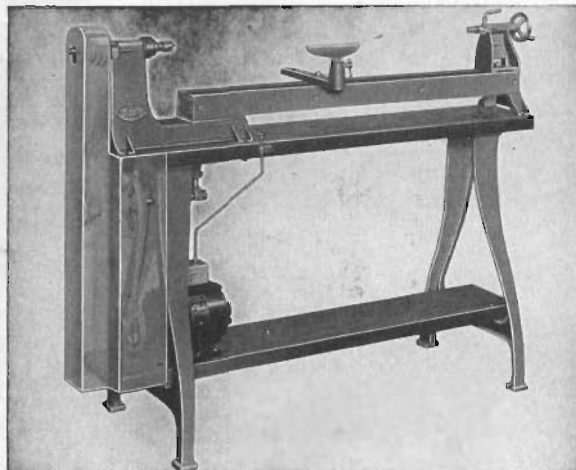

*No. 1710	Bench, 10" x 60" x 34" high, for 42" Lathe, includes shelf.....
No. 1765	Motor, 1/2 h.p. with push-pull switch....
No. 1016	V-Pulley, 6" dia., for motor.....
No. 1012 1/2	V-Pulley, 2 1/2" dia., for motor.....
No. 1046	V-Belt from motor to countershaft.....
No. 1045	V-Belt from countershaft to lathe.....
No. 1708	Countershaft, complete with all three pulleys, hangers, and end collars.....
**No. 1720	Eight-Speed Mounting for 42" Lathe, complete as itemized above. Ship. wt. 220 lbs.
No. 1722	Same, except 4 speeds only.....
No. 1723	Belt Guard for No. 1722 unit. Ship. wt. 8 lbs.
No. 1725	Belt Guard for No. 1720 unit. Ship. wt. 12 lbs.....
(*)No. 1710-X	Same as No. 1710 except for 60" Lathe.
(**)No. 1720-X	Same as No. 1720 except for 60" Lathe.

Power Required: No. 1700 lathe, 1/2 h.p. for best results whether wood turning, metal spinning or metal turning.

METAL TURNING EQUIPMENT FOR No. 1700 LATHE

With the addition of a Compound Slide Rest, shown here, and with Point Centers instead of woodturning centers, the No. 1700 Gap-Bed Boice-Crane Lathe performs excellent metal turning. The lathe has the necessary strength and stamina, and the features essential for metal turning.

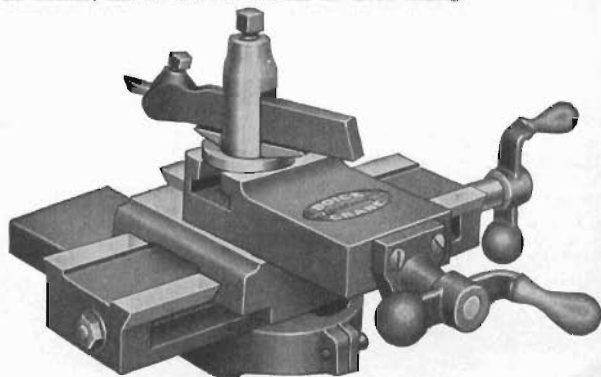

Compound Slide Rest

For Pattern Making or Metal Working. Is of cast iron construction entirely, and has machine-cut lead screws. Longitudinal feed 6 1/2 inches. Cross feed 2 1/2 inches, and swivels to any angle. Standard tool post takes standard tool holders and bits 1/4-inch square. All ways are dovetailed and gibbed, fitted with adjusting screws and also locking devices. Suitable for any 11" swing lathe.

No. 1713	Compound Slide Rest for Pattern Making, or Metal Turning. Includes tool post, holder, and rocker pin. Ship. wt. 22 lbs. (No. 1713 Tool Holder)...
No. 310	1/4" x 1/2" Tool Bits, each. Ship. wt. 2 oz.....
No. 312	Tool Holder for 1/4" sq. bits. Ship. wt. 8 oz...

We can also provide other metal turning accessories, such as 4-Jaw Independent Chucks, slotted face plates, dogs, drill pads, and point centers. The countershaft needed for slow metal turning speeds is described above.

Independent 4-Jaw Chuck

For holding square, or irregular pieces on a lathe. Chuck body is a special quality semi-steel. Jaws have serrated teeth, are reversible and of heat-treated steel. Jaw screws are of hardened steel and have a hexagon socket for wrench. Hubs are bored 5/8" or 3/4" diameter. Locks to shaft by set screw.

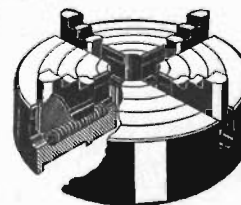

No. 34	4" Independent 4-Jaw Chuck. Fits 5/8" shaft. Ship. wt. 3 1/2 lbs.
No. 35	Same, but fits 3/4" shaft.....
No. 1712	4" Independent 4-Jaw Chuck with fitted plate for 1" x 14 pitch thread. Ship. wt. 9 lbs.....

Other No. 1700 Lathe Metal Turning Accessories

No. 356	Dog. 1/2" capacity. Ship. wt. 1 lb...
No. 357	Dog. 3/4" capacity. Ship. wt. 1 lb...
No. 1711	Slotted Face Plate, 6" dia. Ship. 2 1/2 lbs.
No. 1714	Point Center with No. 2 Morse Taper Shank. Ship. wt. 12 oz.....

LATHE ACCESSORIES FOR WOODTURNING



Four-step Cone Pulley corresponding to pulley on Nos. 1100 and 1700 Lathes. Fits any motor or lineshaft. Runs true. Has socket head set-screw.

No. 1101 4-step Cone Pulley. Specify hole, $\frac{1}{2}$ ", $\frac{3}{4}$ ", or $\frac{1}{2}$ " dia. Ship. wt. 2 lbs.

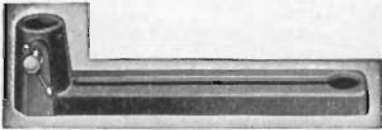

No. 1105 Holder for No. 1100 Lathe. Ship. wt. 2 lbs.
No. 1705 Holder for No. 1700 Lathe. Ship. wt. 3 lbs.

Rigid, cast iron, long reach Holder for T-Rests, complete with clamp. The clamping washer is always pressed up against lock nut by the compression spring, after removal of the holder. Makes it easy for you to put it on again.



Rigid, accurately machined, cast-iron Tee Rests, 8" and 24" lengths. Shank size $\frac{5}{8}$ " for No. 1100 Lathe.

No. 1106 8" Tee Rest....
No. 1107 24" Tee Rest....
 Ship. wt. 2 and 5 lbs.
 Shank size 1" dia. for No. 1700 Lathe
No. 1706 8" Tee Rest....
No. 1707 24" Tee Rest....
 Ship. wts. 2½ and 5½ lbs.



No. 1135 Spur Center for No. 1100 Lathe. Fits over $\frac{5}{8}$ " dia. spindle. Ship. wt. 12 oz.

Spur, or Driving Centers. Four sharply milled teeth. Suited to all sizes of work.

No. 1735 Spur Center with removable center point, and No. 2 Morse taper shank. For No. 1700 Lathe. Ship. wt. 12 oz.



Cup Center for woodturning purposes. Deep cup retains lubricant, and eliminates considerable friction and overheating.

No. 1736 Cup Center with No. 2 Morse taper shank. Ship. wt. 12 oz.



Screw Center Face Plates for woodturning purposes. Removable center point. Accurate. Run true.

No. 1139 and 1738 also fit quill of tail-stock to serve additionally as a Drill Pad.

No. 1139 4-Inch Diameter. For turning of work either upon the right or left (outer) end of the No. 1100 Lathe. Fastens to spindle by hollow head set screws. Ship. wt. 1¼ lbs.

No. 1737 4-Inch Diameter. For right end of spindle only of No. 1700 Lathe. Ship. wt. 2 lbs.

No. 1738 6-Inch Diameter. For right end of spindle only of No. 1700 Lathe. Ship. wt. 2½ lbs.

No. 1739 6-Inch Diameter. For LEFT (outer) end of spindle only of No. 1700 Lathe. Ship. wt. 2½ lbs.

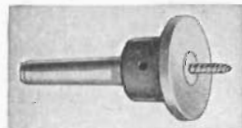

Small sized wooden knobs, drawer pulls, etc., are best turned upon a small face plate like this. Has No. 2 Morse taper shank. Center screw is removable, so it will serve also as a Drill Pad.

No. 1740 Small 2½" dia. Screw Center Face Plate—Drill Pad in one. Ship. wt. 2 lbs.



ARBOR for EMERY WHEELS

No.	For Machine	Dia. Hole in Wheels	Price
51	Meter No. 1601	$\frac{1}{2}$ "	
53	No. 1100 Lathe	$\frac{3}{8}$ "	
55	Motors with $\frac{3}{8}$ " shaft	$\frac{3}{8}$ "	
1709	No. 1700 Lathe, R. H.	1" threaded	
1749	No. 1700 Lathe, L. H.	$\frac{3}{8}$ "	



Frictionless type Steady Rest. Useful to prevent spring and vibration of long, slender turnings. Ball Bearing Rollers will not wear or burn a groove into the wood. Eliminates frequent adjustment as on other types. Open front for quick and easy placement or removal of work from lathe centers. Adjustable $\frac{1}{4}$ " to 6" diameters. Varied shank diameters fit standard T-rest holders.

No. 235 Steady Rest, 1" dia shank. For 1700 Lathe
No. 335 Steady Rest, $\frac{3}{4}$ " dia. shank. For 1100 Lathe
No. 135 Steady Rest, $\frac{3}{4}$ " dia. shank. Average Ship. wt. 4 lbs.



Ball Bearing Back Center: Professional type. Revolves freely under heavy pressure. Is of steel throughout. Has removable center point, and a fine quality ball, thrust bearing. Fine for woodturning use, is essential for spinning. Made with socket, or taper shank, to fit any make of lathe.

No. 1115 Ball Bearing Back Center, with socket to fit all tailstock spindles $\frac{5}{8}$ " dia. as on No. 1100 Gap-Bed Lathe
No. 1117 Same, but with a No. 2 Morse taper shank to fit all spindle socket, as on No. 1700 Gap-Bed Lathe. Average Ship. wt. 1¼ lbs.

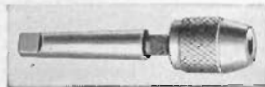

No. 1742 $\frac{3}{8}$ " Drill Chuck with No. 2 Morse taper shank, for No. 1700 Lathe.

Straight or curved edges that have been rough-sawed are easily sanded smooth with this low-cost attachment.

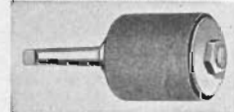

No. 1732 Sand Drum Mandrel with No. 2 Morse taper shank. Fits No. 1700 Lathe. Complete with 3" dia. x 5" wide rubber drum and garnet sleeve. Ship. wt. 3 lbs.

For extra garnet sleeves and drums, see page 33.



No. 1133 Sanding Disc 8" dia., $\frac{5}{8}$ " hole. Fits both ends of No. 1100 Lathe Spindle
No. 1733 Same with $\frac{3}{4}$ " hole. Fits left end only of No. 1700 Lathe

Faced on 2 sides with garnet discs. Average Ship. wt. 1½ lbs.

No. 704 Garnet Discs grade No. 2. Ship. wt. 1½ lbs. Per dozen

Long—WOODTURNING TOOLS—Length



Maple handles, 9" long x $1\frac{1}{4}$ " dia., big enough to grasp and hold securely. Highest quality blades, 9" long beyond handle, will reach into deep turned holes, bowls, etc. Total length averages 18 inches. Professional length.



GOUGES No. Price Each
 $\frac{1}{2}$ " wide.....L-1272
 1" wide.....L-1274
 1½" wide.....L-1276



SPEAR POINT
 $\frac{1}{2}$ " wide.....L-1282
 1" wide.....L-1284
 1½" wide.....L-1286



ROUND POINT
 $\frac{1}{2}$ " wide.....L-1291
 $\frac{3}{4}$ " wide.....L-1292
 1" wide.....L-1294



PARTING TOOLS
 $\frac{1}{2}$ " wide x $\frac{1}{4}$ "L-1302



SKEW, COMBINATION RIGHT AND LEFT
 $\frac{1}{2}$ " wide.....L-1312
 1" wide.....L-1314



SQUARE
 $\frac{1}{2}$ " wide.....L-1321
 $\frac{3}{4}$ " wide.....L-1322
 1" wide.....L-1324
 Average Ship. wt. 1½ lbs.

EVERYTHING FOR SUCCESSFUL SPINNING

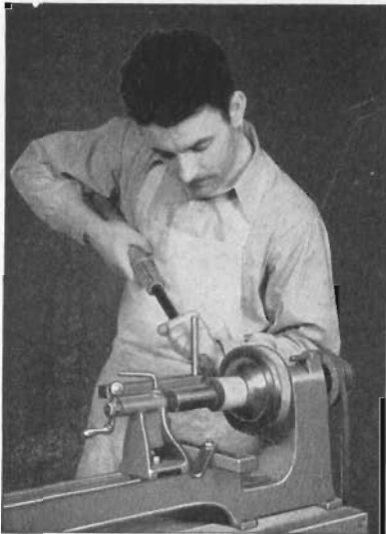

Your spinning equipment, in addition to the lathe, should include: a Spinning Tool Rest, a Spinning Face Plate, and a Ball Bearing Back center of proper size to fit the lathe you select. Also spinning tools for the kind of work you will do. See below for details. All equipment can be furnished too for other makes of lathes. Write for prices.

Sheet pewter, aluminum, etc. also quoted on request.

INSTRUCTION BOOKS ON SPINNING

Plainly written books of instruction. Double the enjoyment out of your lathe with metal spinning. Add to your income too, making beautiful giftwares easily. These books teach you how.

No. 980 METAL SPINNING,
Reagan-Smith.....

First complete text book on the subject. All the fine points but written so the amateur can understand it and become an expert spinner. 80 pages; 35 illustrations; 15 project sheets.

No. 979 HOW TO SPIN METAL..

A fine book for the beginner and for students. Non-technical. 16 pages; 12 illustrations.

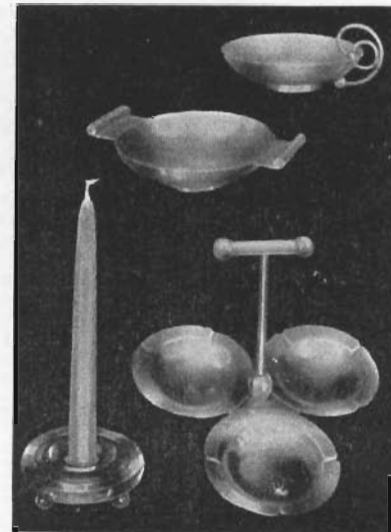

PROFESSIONAL TYPE SPINNING TOOLS AND ACCESSORIES



We guarantee these tools to be professional style and designed by professional spinners. Finest construction throughout. Maple handles 1 3/8" diameter, nicely balanced with easy grip. Tools average 26" overall, a proper size for any craftsman. Tool bits are forged from highest quality carbon steel, then hardened and carefully polished. The five tools listed make a complete, all purpose set.

No. 1125



All Purpose Flat Tool: One portion of tip is flat for smoothing purposes. Opposite side is rounded for "breaking down" and "spinning to chuck" purposes. Portion where flat joins the round is also rounded but to a sharper radius, so this edge can be used to bear into sharply rounded fillets. This is the tool you will use most. It will perform 65% of all spinning on soft metals such as pewter or aluminum. Ship. wt. 3 lbs.

No. 1126



Point Tool: The next most used tool. Used for spinning disc to chuck at very beginning, and for bearing into curves of small radii. Dia. 5/8". Ship. wt. 3 lbs.

No. 1128



Cut-Off Tool: The third, indispensable tool. Used entirely for trimming excess metal from lip of spun object, and for rounding off sharp edges. Ship. wt. 3 lbs.

No. 1129

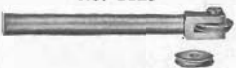

Beading Tool: The fourth tool in value to a spinner. Is used for turning the edge of a spun object to a beaded lip. Can also be used for grooving shallow decorative motifs around bowls. Rolls are interchangeable. Ship. wt. 3 lbs.

No. 1130



Ball Tool: This type is never used on soft aluminum or pewter, and if your work will comprise such metal entirely you do not need this tool. It is for hard metals, such as brass, copper, or steel, and then only for "breaking down" metal to roughly approach the chuck. Never to bring metal to bear snugly to chuck. Ship. wt. 3 lbs.

Spinning Tool Rest: Rest is 10" long, heavily constructed of steel throughout. Has 9 holes to vary location of fulcrum.

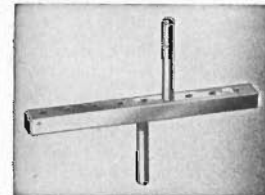

We make them with different diameter shanks to fit the standard tool rest holders of Boice-Crane, and other makes.

No. 1121 Spinning Tool Rest with fulcrum, Shank 3/8" dia. to fit No. 1100 Gap-Bed Lathe.....

No. 1122 Same, but with shank 1/2" dia.....

No. 1123 Same, but with shank 1" dia. to fit No. 1700 Gap-Bed Lathe, and other make lathes.....
Average Ship. wt. 3 lbs.

Ball Bearing Back Center: Professional type. Revolves freely under heavy pressure. Is of steel throughout. Has removable center point, and a fine quality ball, thrust bearing. Fine for woodturning use, is essential for spinning.

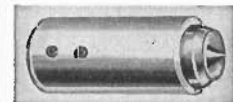

Made with socket, or taper shank, to fit any make of lathe.

No. 1115 Ball bearing Back Center, with socket to fit all tailstock spindles 3/8" dia. as on No. 1100 Gap-Bed Lathe

No. 1116 Same, but with a No. 1 Morse taper shank.....

No. 1117 Same, but with a No. 2 Morse taper shank to fit spindle socket, as on No. 1700 Gap-Bed Lathe
Average Ship. wt. 1 1/4 lbs.

Spinning Face Plate: Differs from a wood-turning face plate. This spinning face plate has a coarse thread, large diameter, blunt nosed screw securely affixed to plate. All this provides strength. The threads on nose act as a "tap" to cut threads in wooden chucks as they are screwed on. Any chuck may be attached any number of times, and it will be held securely, and centrally on plate.

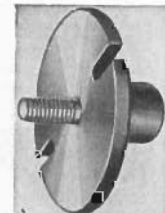

Made by us to fit spindle of Boice-Crane Lathes or other makes.

No. 1110 Spinning Face Plate, 4" dia. Hub fits a 3/8" dia., non-threaded, lathe spindle, as on No. 1100 Gap-Bed Lathe

No. 1111 Same, but hub fits a 1/2" dia. non-threaded, lathe spindle

No. 1112 Same, but with hub to fit a 1" dia. x 14 threads per inch lathe spindle, as on No. 1700 Gap-Bed Lathe

No. 1113 Spinning Face Plate, 6" dia. Hub fits a 1" dia. x 14 threads per inch lathe spindle as on No. 1700 Gap-Bed Lathe. For spinning over 11" dia.....
Average Ship. wt. 2 lbs.

JIG SAW BLADES FOR ALL CLASSES OF WORK

One End of Blades Shown in Full Size

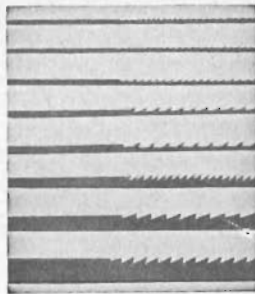

5 Inches Long—Jeweler—Fret—Blades

No.	Thickness	Width	Teeth per inch	Price per doz.	Price per gross
5P-7028	.007	.028	21		
5P-1022	.010	.022	27		
5J-1225	.012	.025	25		
5J-1234	.012	.034	25		
5F-1535	.015	.035	15		
5F-1845	.018	.045	13		
5J-1654	.016	.054	20		
5F-2085	.020	.085	12		
5F-20125	.020	.125	15		



7 Inches Long—Fret Blades

7F-2077	.020	.077	15
7F-20100	.020	.110	15

Common Jig Blades 8 3/4" Long



No.	Thickness	Width	Teeth per inch	Price each	Price per doz.
9JC-1/8	.035	1/8"	9		
9JC-1/4	.035	1/4"	6		
9JC-3/8	.035	3/8"	5		



Metal Cutting Hack Saw Blades 6" Long

9HS-3/8	.025	3/8"	25
---------	------	------	----

Sabre Blades 8" Long

SB-1/8	.035	1/8"	9
SB-1/4	.035	1/4"	6
SB-3/8	.035	3/8"	5

Blades prefixed 5P, are best suited for sawing picture puzzles in stacks of 2 or 3 at a time. Cut very sharp curves without binding. Cut a very narrow kerf, so no detail of picture is lost after reassembly.

Blades prefixed 5J, are best suited for inlaying, overlaying, and marquetry, and also for puzzle sawing.

Blades prefixed 5F, are for ordinary fret work in stock from 3/8" to 1" thick.

Blades prefixed 7F, are best suited for sawing 2" to 3" thick stock into the very sharp curves that a hand saw is not capable of doing, or when a wide set saw kerf is objectionable.

Blades prefixed 9J, are used on thin or thick stock whenever there is no objection to a wide saw-kerf.

Finger Type Blade Guide For No. 2200 Jig Saw



Very useful on No. 2200 Jig Saw, when sawing picture puzzles or when sawing closely to a line with fine blades. Hardened steel. Front edge perfectly smooth. Will never dull the teeth of fine blades. Quickly and easily attached.

No. 2207 Finger guide. Ship. wt. 4 oz.

Smooth Cutting Blades



They are specially ground saws that run with no set to the teeth. They make an extremely smooth cut and perform exactly like a hollow ground saw. Saves the time of sanding that would be required ordinarily if the piece had been cut by a common jig saw blade or by a band saw.

No.	Width	Teeth per inch	Price each	Price dozen
8SC-2	1/8"	8		
8SC-3	3/8"	8		
8SC-4	1/2"	7 1/2		
8SC-6	3/4"	6 1/2		

Ship. wt. each 3 oz. Per dozen 1 lb.

All sizes are 8 3/4" long overall. 1/8" and 3/8" sizes have plain ends with no notch. 1/2" sizes and wider, are notched as shown.

BOICE - CRANE EQUIPS THE FINEST SHOPS COMPLETE



V PULLEYS, 38°

All V Pulleys in the No. 1000 and 2000 Series are of die-cast metal construction, and run true.

No. 1000 Series are furnished with slotted head set screws.

No. 2000 with hollow head safety set screws.

Keyways are not furnished, except when specified, and at an extra charge per pulley.

In sizes 4" diameter and larger, keyways are supplied.

No. 1000 SERIES			No. 2000 SERIES		
For use with only No. 1000 V-Belts			For use with only No. 2000 V-Belts		
No.	Outside Diameter	Price	No.	Outside Diameter	Price
1011	1 1/2"		2012 1/2	2 1/2"	
1012	2"		2013	3"	
1012 1/2	2 1/4"		2014	4"	
1013	3"		2015	5"	
1014	4"		2016	6"	
1015	5"		2018	8"	
1016	6"				
1018	8"				

Adjustable Hangers: Bronze bearing, 1 3/4" long for 3/4" dia. shafting. An elliptical oil groove distributes oil lubricant.

Adjustable 1/4" forward or backward. Adjustable in height from 3 1/2" to 5".

Hangers should be located close to drive pulleys and greatest distance between hangers should not be more than 36". The bushings are so low in price they may be thrown away when worn, and new ones inserted with little trouble or expense.

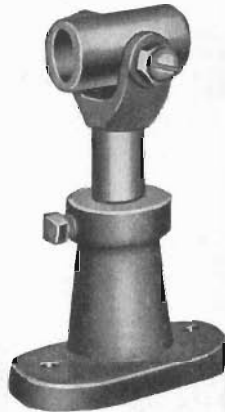

No. 640 Bronze Bearing Adjustable Hanger. Ship. wt. 2 3/4 lbs.

No. 641 Polished Shafting, 3/4" dia. Per foot

No. 642 End Collar. Ship. wt. 4 oz.

V BELTS, 38°

Boice-Crane V Belts are moulded endless, and are uniform in cross-section. During manufacture, the core of the belt is stretched under tremendous tension, so the finished belt can not possibly stretch further when in use.

Boice-Crane V Belts are extremely flexible, will revolve at high speeds and still maintain close contact with very small pulleys. This means a tight grip, and full transmission of power, using only a slight belt tension.

No. 1000 SERIES

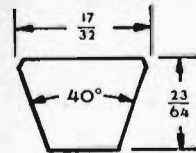

No. 2000 SERIES

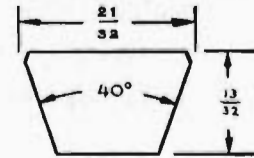

No. 2000 Series V-Belts are heavier in cross-section and will transmit far greater power with less belt tension than No. 1000 Series belts.

Less belt tension causes less wear and strain on belt and bearings.

For these reasons No. 2000 Series V-Belts are greatly preferred on such heavy duty Boice-Crane Machines as our No. 1400 6-inch Jointer, No. 2500 Tilting-Arbor (10-inch) Saw, and No. 1000 Thickness Planer.

No. 2000 Series V-Belts, and V-Pulleys may be purchased for other heavy duty applications, in which the motor power to be transmitted is 1/2, 3/4, 1, or 1 1/2 h.p.

No. 1000 Series V-Belts and V-Pulleys are for 1/4 h.p. or less.

No.	Outside Length	Inside Length	Price Each
1030	30	27.7	
1031	31	28.7	
1032	32	29.7	
1033	33	30.7	
1034	34	31.7	
1035	35	32.7	
1036	36	33.7	
1037	37	34.7	
1038	38	35.7	
1039	39	36.7	
1040	40	37.7	
1044	44	41.7	
1045	45	42.7	
1046	46	43.7	
1048	48	45.7	
1052	52	49.7	
1058	58	55.7	
1060	60	57.7	
1068	68	65.7	
1072	72	69.7	
1094	94	91.7	
1096	96	93.7	

No.	Outside Length	Inside Length	Price Each
2042	42.3	39.7	
2046	46.3	43.7	
2048	48.3	45.7	
2050	50.3	47.7	
2052	52.3	49.7	
2054	54.3	51.7	

HANDY MACHINE LAMPS FOR YOUR BOICE-CRANE MACHINES

Fine Sawing Requires Good Lighting



No. 2200—24" Jig Saw has tapped hole ready to receive single screw to attach lamp. Mounts out of the way.

Boice-Crane Machine Lamps were developed to solve your lighting problems. Most overhead lamps do not concentrate the light sufficiently for efficient machine operation. This problem is especially acute where work is mostly done at night. These lamps throw all their light directly on the work. They become a part of the machine, making relocation of overhead lights unnecessary if machine is moved or the shop rearranged.

Have Many Other Uses

These lamps are for other machines too. You will find a dozen places around the home where they are just the thing you have wanted.

No. 115 Machine Lamp complete with bracket, double swiveling arm, 8-foot cord and plug and attaching screw. No bulb. Ship. wt. 1 lb.

Notice particularly how the Boice-Crane lamp may be focussed exactly at cutting point or on spot being drilled or mortised.

This is an exclusive feature made possible by an arm that swivels in two directions. This one style of mounting bracket takes care of all machines.

The lamp socket has its own control switch . . . so operator can instantly snap on the light without having to walk to some distant point across his shop.

Light Exactly Where Needed For Greater Safety—Better Work



No. 1600—Drill Press. Simply remove one guard attaching screw to mount lamp on drill press.

ROUTER BITS



Dia.	1/4"	5/16"	3/8"	7/16"	1/2"	5/8"	3/4"
Price							
No.	174	175	176	177	178	180	182

WOOD MACHINE BITS WITH BRAD POINT



Dia.	1/4"	5/16"	3/8"	7/16"	1/2"	5/8"
Price						
No.	74	75	76	77	78	80

PLUG CUTTERS (BEST QUALITY)



Dia.	3/8"	1/2"	5/8"	3/4"	7/8"	1"
Price						
No.	276	277	278	280	282	284

MORTISING CHISELS--BITS--BIT BUSHINGS

The Mortising Attachments for both the Boice-Crane Saw Table and Drill Press, are for heavy duty, fully able to do the work ordinarily done on an individual Mortising Machine.

In keeping with the heavy duty capacity, we recommend the use of standard production type and quality Hollow Chisels and Bits, and list just one grade—the best.

They may be used on the hardest materials, mortising to their very limit of depth capacity, without danger of burning or removing the temper. Consequently they hold their edge longer.

They cut fast and clean, as they are made with two large rapid chip clearance openings.

A single chisel and bit will last for years. True economy results when you buy Boice-Crane mortising tools manufactured by one of the oldest and most successful firms in the business.

BUSHING



No bushings are required with our Helmet Head Drill Presses, because bits are held directly in chuck. Bushings are for use with Drill Presses Nos. 1600-10 and 1650-60.

No.	Bit Size	Dia. Hole	Price
794	1/4"	1/4"	
795	5/16"	5/16"	
796	3/8"	3/8"	

For Drill Press and Saw Mortising Attachments

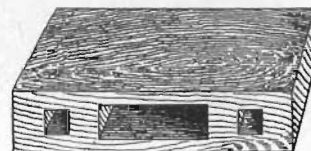

CHISEL



No.	Size	Depth of Mortise	Price
774	3/4" x 1/4"	1 3/8"	
775	1 1/8" x 1/8"	1 3/8"	
776	3/8" x 3/8"	3 3/4"	
777	1 1/8" x 1/8"	3 3/4"	
778	1/2" x 1/2"	3 3/4"	

Ship. wt. each, 8 oz.

MORTISING BIT



No.	Size	Dia. Shank	Price
784	1/4"	3/8"	
785	5/16"	3/8"	
786	3/8"	3/8"	
787	1/2"	3/8"	
788	5/8"	3/8"	

Ship. wt. each, 6 oz.

EVERY SHOP CAN USE THIS PRACTICAL 3" x 12" DRUM SANDER

A Machine You've Always Wanted: How many times haven't you wished you could buy a large Power Drum Sander at a price really within reach? Here is exactly what you have been looking for. A big capacity, efficient, labor saving Drum Sander so low in price that every craftsman can afford one in his shop now.

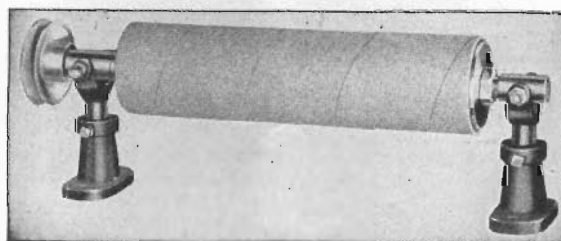

Beats Hand Sanding: The Boice-Crane Power Drum Sander will do all of your sanding jobs better, quicker, and practically without effort. Compared to hand sanding, which is such an awfully tedious job, it is lightning fast. Your projects will take a better finish too. One week's use will convince you it is a mighty good investment.

Dozens of uses: You can use this Sander many times on every project. It will sand the edges of straight and irregular shaped band and jig sawed pieces. It will finish sand the faces of wide and narrow stock. One of the uses you will appreciate it most for is finishing resawed stock too wide to dress on your jointer.

Few Dollars Buy All Essential Parts: You buy just the essential parts from us, namely, the mandrel; rubber expansion drum; abrasive sleeves; two bushed hangers; and the pulley. The outfit is priced complete. No table is included however. You make your own from wood as suggested in the sketch below.

No. 760	Sand Drum Mandrel, complete as shown. Includes mandrel, rubber expanding drum, garnet sleeve, two bronze hangers, and V-Pulley for belt drive. Ship wt. 14 lbs. Only
No. 761	Extra Garnet Sleeves, Nos. 1/2, 1 and 1 1/2 grit. Ship. wt. 3 lbs. Price for three

TABLE EASY TO MAKE—SAVE TWO-THIRDS THE COST OF THE MACHINE

The table is easy to make as there are no table adjustments to be provided for. The drum is placed in position exactly level with the rear table by adjusting the height of the hanger posts. The front table is slightly lower but parallel to the rear one. We suggest making the entire table and supporting frame detachable from bench so you can do curved sanding.

This will make you an efficient, accurate and all around useful Drum Sander for a few dollars, equal to most any \$30 to \$50 machine.

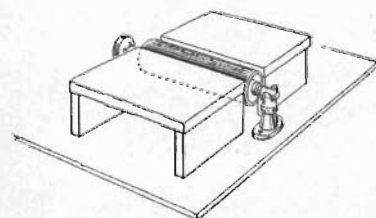

BOICE-CRANE MOTORS HAVE HEAVY-DUTY 2-POLE SWITCH

TO START

Only an intentional pull by operator starts this ever safe switch.

TO STOP

No groping for a tiny toggle. The broad palm of your hand can't miss this switch-knob.

NO ACCIDENTAL STARTS

A falling object can only throw switch to STOP.

REMOTE CONTROL

FROM ANY CONVENIENT LOCATION

SUITABLE FOR REMOTE CONTROL

A lifetime of trouble-free starts and stops from this larger, really heavy-duty, 2-pole switch.

A few noteworthy construction features are: larger, heavier switch-points; thicker insulation against shorts; eight fiber-shields to guard "off-position" and to snuff arcing; and a very rapid snap-action that shortens arcing to small flashes.

Notice also our large Control Knob. It is a big easy target to strike by palm of hand . . . for stops, easy to grasp . . . on starts. Its big shaft and bearing of steel are indestructible.

This better construction saves you aggravating breakdowns and repairs.



The massiveness of this Boice-Crane Switch (4 x 2½ x 2¼ inches) shows it is not limited to light homeshop usage, but for heaviest factory service.

One-Shaft for No. 2514 Saws					Two-Shaft for No. 2529 Saw-Jointers		
No.	Price	H.P.	Voltage at plug	Bearings	Ship wt. lbs.	No.	Price
2565		½	110	Ball	62	2566	
2567		½	220	Ball	62	2568	
2575		¾	110	Ball	62	2576	
2577		¾	220	Ball	62	2578	
2585		1	110	Ball	69	2586	
2587		1	220	Ball	69	2588	
2595		1½	110	Ball	145	2596	
2597		1½	220	Ball	145	2598	



S A W
SAW-JOINTER

FOR BEST POWER...BEST MOTOR CONTROL...AT LOWEST PRICE

ALL 1-PHASE MOTORS

On This Page
Are
REPULSION-INDUCTION
1750 RPM.*

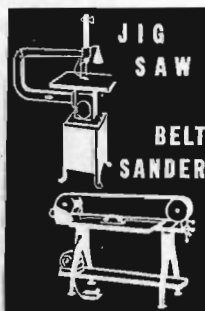
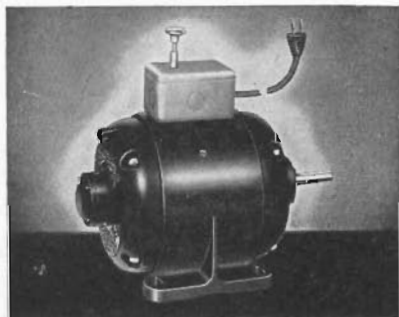

No.	H.P.	Voltage at plug	Bearings	Ship. wt. Lbs.	Price
1455	¼	110	Ball	34	
1457	¼	220	Ball	34	
1465	½	110	Ball	62	
1467	½	220	Ball	62	
1475	¾	110	Ball	62	
1477	¾	220	Ball	62	
1485	1	110	Ball	69	
1487	1	220	Ball	69	

INSIST ON THESE MOTORS...ENGINEERED BY BOICE-CRANE

Abreast each of the 3 classes of motors (which differ in switch location), we illustrate those Boice-Crane Machines for which each class of motor is intended. For those who have other appliances to motorize, one of these 3 classes of complete, switch-equipped Boice-Crane Motors is sure to save you real money.



The prices of Boice-Crane Floor Stands always include the proper Push-Pull extension rod, to locate the operating knob of switch at the most convenient place on machine. We list motors in each single voltage to avoid mistakes on switch connections. Please order by catalog number. But remember, all Boice-Crane R-I motors are dual (110-220) voltage and may be connected for either 110, or 220 volt at any time by merely interconnecting the motor-leads to switch terminals. Motors of 2500 and 1400 series rotate counterclockwise; 1700 and 2600 series rotate clockwise, as viewed from shaft end. Rotation may be reversed at any time by shifting position of brush-ring.

Prices of 3-phase ball-bearing motors do NOT include cord, plug, nor switch. However when the 3-phase switch is also purchased, the switch is mounted on machine and motor-leads connected to switch terminals, thru metal conduit. Customer to supply and connect 3-phase service line and plug.

No.	H.P.	Voltage at plug	Bearings	Ship. wt. Lbs.	Price
1755	½	110	Ball	34	
1757	½	220	Ball	34	
1765	¾	110	Ball	62	
1767	¾	220	Ball	62	
1601*	½	110	Ball	33	
2655	¼	110	Ball	34	
2657	¼	220	Ball	34	
2665	½	110	Ball	62	
2667	½	220	Ball	62	

*No. 1601 Motor is a ½ h.p. Split-Phase 1-shaft, with one pole switch. For No. 2200 Jig Saw, No. 200 Wet Grinder, and other tools with low starting loads.

SPINDLE SANDER



DRILL PRESS



3-PHASE MOTORS (Also see note at left)

No.	1-Shaft	Horse Power	Ship. wt. Pounds	Volts	No.	2-Shaft
885		½	32	220	886	
887		¾	55	220-440	888	
889		1	88	220-440	890	
891		1½	110	220-440	892	

No. 899 Starting Switch only, not mounted, heavy duty for 3-phase motors listed above. Ship. wt. 10 lbs. Specify single voltage for switch connections.

Boice Crane

12" x 4" THICKNESS PLANER

SPECIFICATIONS

CAPACITY:	{	Widest Stock	12 inches
		Thickest Stock	4 inches
		Thinnest Stock	$\frac{1}{16}$ inch
		Shortest Stock	6½ inches
MAXIMUM DEPTH OF CUT		$\frac{1}{8}$ inch	
RATE OF FEED:	{	Head running 3500 r.p.m.'s	14 ft. per minute
		Head running 4500 r.p.m.'s	17½ ft. per minute
CUTS PER INCH OF MATERIAL		60	
TABLE SIZE		20" x 12¼"	
FRAME: One-piece casting, rigidly ribbed. Weighs 150 lbs. alone.			
CUTTERHEAD: 3 knife, 2⅜" dia. (Cutting Circle 2⅞" dia.)			
CUTTERHEAD BEARINGS: S.K.F. self-aligning Ball-Bearings.			
FEED ROLL BEARINGS: Bronze in self-aligning journals.			
FEED ROLLS: Two, each 2¼" dia. One corrugated and hardened. One smooth.			
POWER REQUIRED: 1½ to 2 horsepower. Belt or Direct Drive.			

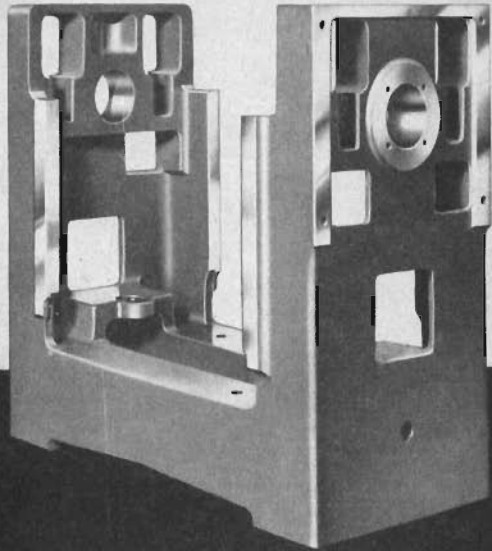

A

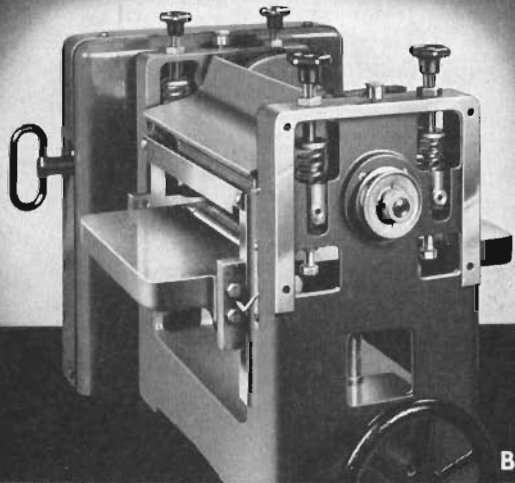

B

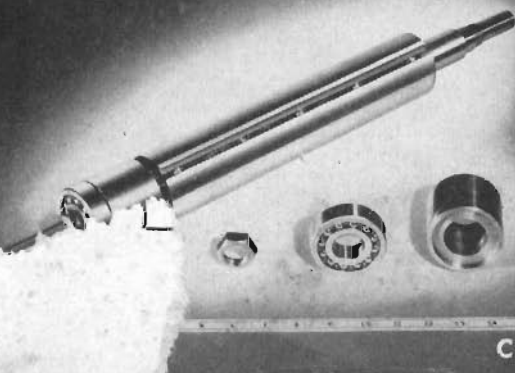

C

WORLD'S LARGEST BUILDERS OF 12-INCH PLANERS

● Unlike others, that are designed to feature low price, the heavy duty Boice-Crane 12" x 4" planer is the only one that includes every essential feature of larger, more expensive planers—features that return two dollars to the user for every single dollar extra invested in a Boice-Crane.

Boice-Crane introduced their first 12" x 4" planer over fifteen years ago. It has been constantly improved since.

Today, as the world's largest builder of 12" planers, Boice-Crane enjoys a sales volume which enables them to include all wanted features—at a price \$50.00 to \$100.00 under what you would expect to pay.

Of all the machines of its class, the Boice-Crane alone can point to thousands of successful installations, many dating back ten, fifteen, and more years. (Machine serial No. 1 still operates daily in New England, having planed millions of feet of hard wood.)

FOR LARGE SHOPS—SAVES MONEY ON LARGE WORK

The Boice-Crane 12" planer is not only practical for small shops, and jobs under 12" wide, but also saves the needless investment of hundreds of dollars wherever it is installed, even for working table tops, desk tops, drawing boards, and other work wider than 12". This has been proven in thousands of installations in furniture plants, schools, antique shops, sign plants, etc.

The method employed is to plane pieces under 12" wide before gluing, then quickly sand off glued joints on the Boice-Crane 6" x 60" hand stroke belt sander. The saving of this simple Boice-Crane 2-machine method over the cost of an 18", 24", 30" or 36" planer is enough to pay for several other machines for other purposes. Hundreds of dollars are saved annually in power alone, when you can operate a Boice-Crane to capacity with 2 H.P. motor or less, even on single phase wiring if necessary, instead of the 5 to 10 H.P. motors required by larger planers.

It saves valuable floor space for the large shops as well and is recommended as an auxiliary machine.

DOES JOBS LARGE PLANERS CAN'T DO

A Boice-Crane will do a better job than a large planer when running extremely short, narrow, or thin stock. In fact its short coupling of essential parts equips it for jobs no large planer *can even attempt*—such as planing material as short as 6½"; planing hard woods down to $\frac{1}{16}$ " thick, smooth as silk and to a thousandth of an inch precision without tearing. In these ways it piles up big money savings by keeping valuable short and thin stock out of the scrap heap and in other ways saves you the expense of having certain parts and jobs done outside, as is necessary if you have only a large planer.

DESIGNED FOR SUPERIOR PERFORMANCE—MASSIVE FRAME

Foundation of the sturdy, built-to-last Boice-Crane planer is the one-piece main frame. See A. The usual method of bolting up several castings can never guarantee the lifetime alignment of the cutterhead bearing seats and table ways that are basic in a Boice-Crane. This valuable feature is usually reserved only for large expensive planers.

The Boice-Crane frame has extra weight for reserve brute strength to absorb the gruelling punishment which a planer must take. To assure permanent freedom from distortion and misalignment, Boice-Crane chose for its planer a precision moulded, close grained, seasoned, grey iron casting. It is massively proportioned and alone weighs 150 pounds.

POWER FEED

Two power driven upper feed rolls, one (infeed) is corrugated, the other (outfeed) smooth. Also two table idler rolls—a feature often omitted to reduce machine price.

Power driven rolls operate in bronze-bushed self-aligning journals—arranged adjustable for fixed height, but also arranged to automatically lift vertically with a wide range of adjustable spring pressure. These unique spring-loaded feed rolls insure positive feed even when small variations of thickness are present in the work passing through. See illustration B.

A FINER FEED MECHANISM

Thousands in use for up to fifteen years without replacement or repairs. Fewer and less complicated parts. No troublesome clutch. Quieter. Only two simple adjustments ever needed. Extra smooth and extra powerful. Most feed drive parts are standard v-belt, sprocket, and silent roller chain you can buy anywhere if replacements ever are needed. See illustration E.

Equipped for instant power feed control. The feed can be stopped without stopping the motor, engine or lineshaft power. This is particularly important in the latter two cases.

Fourteen feet per minute standard feed rate guarantees high production. Can be arranged for ten feet per minute feed at time of ordering, without extra charge. Latter recommended for finest cabinet planing of extremely hard woods.

Idler table rolls are also closely adjustable for height. They assure positive non-halting feed under all conditions from smooth work face to rough resawed surfaces.

CHIP BREAKER—PRESSURE BAR

Boice-Crane planer design here follows the most thorough-going and time proven practices of leading woodworking machine designers. Illustration F clearly shows how these two parts, so vital to planer performance, closely follow the round contour of the head—ending in closely coupled shoe surfaces that engage the work closely ahead and behind the actual cut. The chip breaker and pressure bar shoes on a Boice-Crane are perfectly milled to a true arc. This guarantees absolute contact with the work at every point across the entire length, but without the extra drag of flat or unmachined shoe surfaces.

Only when both the pressure bar and chip breaker are mounted concentric with the cutterhead, and only when the chip breaker is spring controlled for wide range adjustment as on a Boice-Crane—can a planer be perfectly tuned for wide work range. The Boice-Crane will handle everything from the fine work of a cabinet maker to the rapid output demands of small mills and lumber yards.

CUTTERHEAD

Comparison is invited to this detail when selecting your 12" x 4" planer.

Three high speed steel knives held by tapered chip-breaker type wedges, each wedge having five hardened jack screws. Head carefully balanced. Three inch cutting circle. Complete head with shafts is turned in one piece from a solid steel bar. This feature alone is worth many dollars. Assures longer usable machine life at peak capacity. Also far safer than the questionable economy of set-screwing shaft into head—a common fault of planers featuring price alone.

Extra heavy duty S K F bearings with self-aligning inner race, are precision mounted and each independently *locked* in place. This is the bearing mounting system employed in all high grade machinery. Contrast with the light duty, babbit-held bearings sometimes employed. See illustration C.

12 1/4" x 20" TABLE

Heavy walls and exceptionally well ribbed. Ground flat and seasoned to stay flat. Travels on four machined-ways, and four (not the usual two) adjustable gibs take up any wear that develops after years of use. Large, oversized, lightning-fast table lifting screws are thrust bearing mounted—another proof of Boice-Crane quality carried right down to minor hidden points. Accurate scale graduated in sixteenths of an inch for setting work thickness. See B.

CHOICE OF DRIVES

Boice-Crane solves all drive problems, odd voltage conditions. You have a choice of 1 1/2 and 2 H.P. direct to cutterhead, or v-belt electric motor drive for bench mounting or complete floor type units. Also drives from lineshaft or gasoline engine. All listed and illustrated on back page.

SAVES MONEY FOR EVERY USER LARGE PLANTS

Saves money every day for large industrial woodworkers, first by the extremely economical practice of doing small work on a smaller, more suitable machine. Also by making a larger planer unnecessary when a Boice-Crane 12" x 4" is installed in tandem with our 6" x 60" hand stroke belt sander to produce and completely finish large glued up tables, desk tops, drawing boards, etc. Then by salvaging for profitable use, such short, thin and otherwise waste stock that large planers can't handle. Finally it is always ready as an auxiliary planer, to speed up production and relieve congestion anywhere on the production line. Saves hundreds of dollars annually in extremely low power consumption.

SCHOOLS AND JOB SHOPS

Meets the exacting requirements of schools, lumber yards, pattern and cabinet shops, boat yards, and mills, enabling everyone to enjoy all of the conveniences and economies of having their own planer, yet with a very low investment.

HOME SHOPS

A Boice-Crane planer saves money for homecrafters by greatly reducing the number of stock sizes. Rough stock can be planed to exact thickness as needed. You get better stock buying that way, and at lower prices too. Saves you mill charges on planing small lots, and those frequent time-consuming trips to the mill. Every job is run *just like you want it*, with a perfect surface ready to finish *without sanding*.

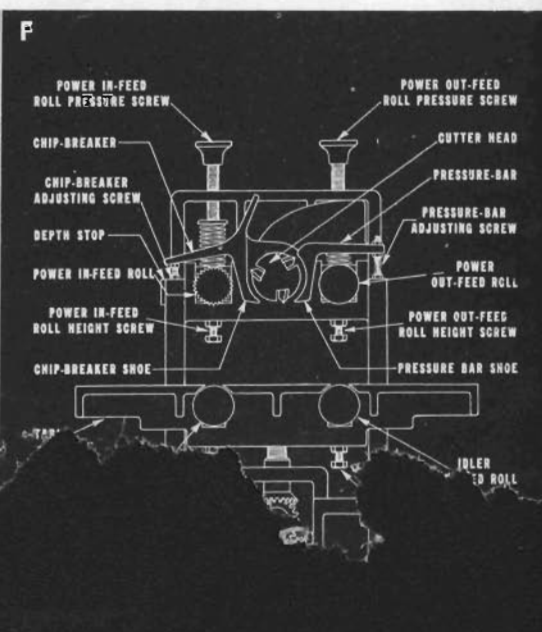
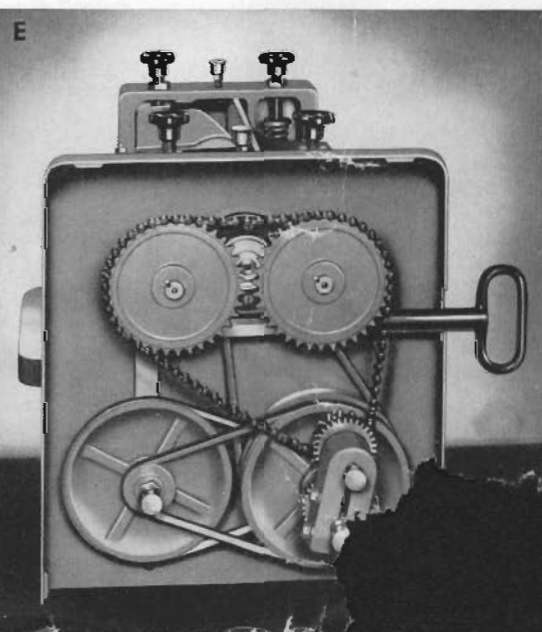
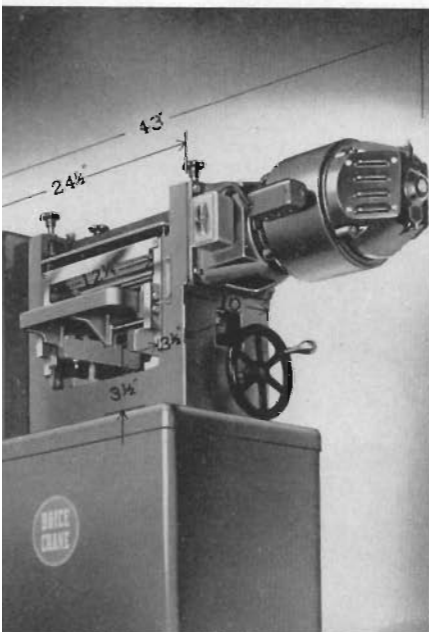

A CHOICE OF SEVEN MODELS

DIRECT-MOTOR-DRIVE BENCH TYPE MODELS

- | No. | | Price |
|------|---|-------|
| 1002 | Boice-Crane 12" x 4" Thickness Planer, with one set of 3 knives, 1½ h.p. ball bearing, Repulsion-Induction Motor direct connected to cutterhead, for 110-220 volt, 60 cycle, 1 phase A.C. including motor bracket, switch (Illustration H)
Net weight 450 lbs.
Shipping weight—Domestic 535 lbs. Export 655 lbs. 25 Cu. Ft. | |
| 1004 | Same as No. 1002 except with 2 h.p. motor for 110-220 volt, 60 cycle, 1 phase A.C.
Net weight 470 lbs.
Shipping weight—Domestic 555 lbs. Export 675 lbs. 24 Cu. Ft. | |
| 1005 | Same as No. 1004 except with 2 h.p. motor for 220-440 volt, 60 cycle, 3 phase A.C.
Net weight 470 lbs.
Shipping weight—Domestic 560 lbs. Export 645 lbs. 24 Cu. Ft. | |
| 1001 | Cabinet Floor Stand for all above models (Illustrations I and J)
Net weight 110 lbs.
Shipping weight—Domestic 150 lbs. Export 175 lbs. 10 Cu. Ft.
NOTE: Direct connected motors can be furnished for Direct Current. Belt-drive motors only for 25, 40, or 50 cycle A.C., single or polyphase. Write for special motor prices. | |

V-BELT DRIVE FLOOR TYPE MODELS

- | No. | | Price |
|------|---|-------|
| 1000 | Boice-Crane 12" x 4" Thickness Planer, with one set of 3 knives, 3" diameter V Cutterhead Pulley for ¾" wide V-Belt, No. 2016 6" diameter V Motor Pulley for ¾" wide V-Belt (¾" or 1" bore—specify which) (Illustration G)
Net weight 345 lbs.
Shipping weight—Domestic 425 lbs. Export 485 lbs. 17½ Cu. Ft. | |
| 1006 | Consists of No. 1000 12" x 4" V-Belt Drive Planer, No. 1001 Cabinet Floor Stand, No. 2016 Single Groove Motor Pulley for ¾" wide V-Belt, No. 2074 V-Belt ¾" wide, No. 1006-1 1½ h.p. ball bearing, Repulsion-Induction Motor for 110-220 volt, 60 cycle, 1 phase A.C., No. 599 2-pole Switch, Cord and Plug. (Illustration J)
Net weight 555 lbs.
Shipping weight—Domestic 675 lbs. Export 760 lbs. 27½ Cu. Ft. | |
| 1007 | Same as No. 1006 except with No. 1016-2 Twin Groove Motor Pulley for ½" wide V-Belts, 2 No. 1072 V-Belts ½" wide, No. 891 1½ h.p. ball bearing, poly-phase Motor for 220-440 volt, 60 cycle, 3 phase A.C., No. 899 heavy duty 3 phase Switch, no cord or plug
Net weight 555 lbs.
Shipping weight—Domestic 675 lbs. Export 760 lbs. 27½ Cu. Ft. | |
| 1008 | Same as No. 1007 except with No. 1009-1 2 h.p. motor for 110-220 volt, 60 cycle 1 phase A.C.
Net weight 605 lbs.
Shipping weight—Domestic 725 lbs. Export 810 lbs. 27½ Cu. Ft.
NOTE: Belt drive motors can be furnished for 25, 40, or 50 cycle A.C., single or polyphase. Prices for Belt Drive Models for 25, 40 or 50 cycle A.C., single or polyphase quoted on application. | |

ACCESSORIES

- | No. | | Price |
|------|--|-------|
| 1003 | Extra 12" High Speed Planer Knives, per set of 3.
Net weight 12 ozs.
Shipping weight—Domestic 2 lbs., 4 ozs. Export 2 lbs., 4 ozs. | |
| 1001 | Cabinet Floor Stand
Net weight 110 lbs.
Shipping weight—Domestic 150 lbs. Export 175 lbs. 10 cu. ft. | |
| 1010 | Belt Guard for models Nos. 1000, 1006, 1007, 1008. Heavy gauge steel. Illustrated at J
Net weight 12 lbs. Shipping weight 15 lbs. | |

ALL PRICES F.O.B. FACTORY AND SUBJECT TO CHANGE WITHOUT NOTICE

Any National or State tax now or subsequently levied is to be added to price quoted. We reserve the right to make changes in design, specifications, or equipment at any time without incurring any obligation to install these on any machines already sold.

Boice-Crane products manufactured and sold under the following patents either owned by Boice-Crane or under which we are licensed:

1,790,288	1,967,791	2,166,703	2,347,764
1,894,010	2,049,044	2,211,050	2,347,765
1,902,270	2,049,045	2,256,607	2,371,731
1,922,151	2,107,174	2,260,635	2,384,364
1,927,477			2,431,605

Design Patent Nos. 113,369, 115,779, 131,216, 154,530. Other United States Patents Pending

BOICE-CRANE COMPANY, TOLEDO 6, OHIO

Agents: **Oren O. Gallup, Inc.** 2 Lafayette St. New York 7, N.Y.
Irving S. Kemp Co. 218 N. Jefferson Chicago 6, Ill.
Chicago Display

SAW & TOOL CO.

SAN FRANCISCO 3
1072 HOWARD ST.

OAKLAND 6
950 E. 14th ST.

PRINTED IN U. S. A.

